

THE OHIO STATE UNIVERSITY
OFFICIAL PROCEEDINGS OF THE
NINETEENTH MEETING OF THE
WEXNER MEDICAL CENTER BOARD

Columbus, Ohio, January 25, 2017

The Wexner Medical Center Board met on Wednesday, January 25 at the Richard M. Ross Heart Hospital, Columbus, Ohio, pursuant to adjournment.

** ** **

Minutes of the last meeting were approved.

**

January 25, 2017 meeting, Wexner Medical Center Board

Mr. Wexner called the meeting of the Wexner Medical Center Board to order on Wednesday, January 25, 2017 at 9:04am.

Present: Leslie H. Wexner, Alex Shumate, William G. Jurgensen, Cheryl L. Krueger, Abigail S. Wexner, Robert H. Schottenstein, Michael V. Drake, Sheldon M. Retchin, Geoffrey S. Chatas, K. Craig Kent, Amanda N. Lucas, Elizabeth O. Seely, and Marti C. Taylor. Janet B. Reid, Corbett A. Price, David B. Fischer, Stephen D. Steinour, E. Christopher Ellison, and David P. McQuaid were absent. Michael A. Caligiuri was late.

Ms. Link:

Good morning everyone. We are going to convene the meeting of the Wexner Medical Center Board and I would like to note that a quorum is present. The minutes of the November meeting of the Wexner Medical Center Board were distributed to all members, and if there are no additions or corrections, the minutes are approved as distributed. I would like to now call on Dr. Sheldon Retchin for his CEO Update.

Dr. Retchin:

Thank you, Heather. I appreciate it. I will start by first recognizing a new member of the board, I think this is your first meeting of this cycle. Bobby Schottenstein, who actually was the architect, or one of the architects for the medical center board itself. A warm round of applause, of course, everyone recognizes there will be a routine hazing ceremony afterwards. Let me go right into my report.

First of all, an announcement, yesterday, Upper Arlington awarded the Upper Arlington Business of the Year, was Monday night actually, for our Upper Arlington Kingsdale Center. We were mentioned in the State of the City Upper Arlington Address and they received proclamations from the state Senate and House. How about a round of applause for that?

Next, before I go on the scorecard, I want to update the board and there will be further discussion on this in Mr. Kasey's report. As you may know, the president introduced Framework 2.0 last week and after that, I hosted three parking forums on Monday, January 23rd, this week, for the Wexner Medical Center staff to unveil the Framework 2.0 and its long-term plan and vision to reach our potential as an exemplary research, teaching, and learning campus. The framework was enthusiastically received. We then discussed some of the things, the enabling projects, to realize Framework 2.0, which is, and I guess some of the elements of Framework 2.0 are available online but a big part of this, of course, is the movement of Cannon Drive, which came from 1.0. This enables us to recapture and repurpose 12 acres of land and Mr. Kasey will go over some of the elements of the transportation plan that results from us having to close the polo lot. Let me go to the scorecard, if you'll go behind the tab labeled CEO Update and I will call on different individuals along the way. If you wouldn't mind that those that I call on would get to the mic and I will start with Mamoon Syed, the Director for Human Resources, to talk about our people and the measurements on engagement score, diversity and inclusion, and employee turnover rate and how we are making headway. Mamoon?

Mr. Syed:

Thank you Dr. Retchin. Regarding the engagement score, we do a biennial employee engagement survey which is scheduled for November of this calendar year. What we're doing in the interim is a poll survey which the results we will get here in a couple of months. By way of actual outcomes, we do not have anything to report until the next board meeting. Regarding diversity and inclusion, this is a new metric that we've added to the corporate scorecard for the Wexner Medical Center to directly and deliberately support the president's vision around inclusive excellence. One of the unique elements within the medical center's diversity and inclusion strategic plan, vis-à-vis what the university is doing, is going to be around health disparities and how we become a

provider of choice and the care that we provide to a diverse patient population. In partnership with Dr. McDougall and others, we are working on developing a plan to evaluate that data and develop a plan to curb the tide of any health disparities that exist. We are looking to finalize that plan over the next few months and our goal is to have that plan before the end of this fiscal year. More importantly, and in follow up to conversation from the board meeting last time, employee turnover for both faculty and staff is also a new metric that we've added to the corporate scorecard. There is a lot of attention and analysis that is going into this turnover, so we are looking at both faculty and staff separately and we are actually segmenting the data within each of those two buckets. When we look at staff turnover, what we are doing is a segmented analysis by different job types, by different demographic categories, age, gender, race, ethnicity, and really trying to identify, are we having a more acute challenge in turnover in some places over than other.

(alarm goes off)

Related to staff, we definitely have a good action plan in place that is focusing on the very specific job categories where we see a very high turnover rate which is specifically in our environmental services tech and food service workers, as well as a slight increase in turnover for nurses. We have a team mobilized looking into how we can improve that tide of turnover for nurses.

The other category for staff that we are really paying attention to right now is turnover in the first year and we have a team looking at that. We don't have specific action plans identified for that group yet but the data definitely identifies that is a category of staff that we want to look at. As it relates to benchmarking, because that question was raised as well for staff, we are operating at about the 65th percentile of the data as it relates to staff turnover. Looking at faculty, there is also a partnership with Dr. Kent and others and we are definitely slicing and dicing to look at faculty turnovers. When it comes to physician turnover, the benchmark is around 7%, 6.8% to be exact in the most recent data that came out from Becker's Review and Cejka and we 9.6% is where we ended up last year. There is a lot of analysis around faculty turnover and what's happening over the last couple of years we're doing exit interviews with every single faculty member that leaves this organization. We have about a 60% response rate, not only to the survey but the in-person conversation and that is actually providing us with some very rich information about how we are going to focus.

As you would imagine, it is very varied with respect to what physicians are telling us but there is probably one trend that we are hearing about over the last couple of years that is prompting some of our faculty members to leave that we are paying special attention to and that is a focus on the academic environment here at the Wexner Medical Center. With the recruitment of Dr. Kent and his focus on, and you're going to hear about this later in the agenda about our comp plan, that we are really focusing on instituting efforts and initiatives that we believe are already curbing the tide for our faculty turnover rates. When we look at our first six months of turnover last fiscal year and compare that to the first six months of turnover from this fiscal year, we're already seeing that trend heading in the right direction. We are feeling really positive about where we are headed but we know we still have a lot of effort and initiative to do in that regard.

Dr. Drake:

If we are going to look at that, then I would be very interested in a segmented, or differentiated, segmented look at who exactly we're speaking of and where they are going since when we say faculty member, there's a wide variety of activities that those people are engaged in. I would be very interested in who exactly was leaving and then where they are going i.e. did they go to non-academic places here in town or did they move to Oklahoma or New York.

January 25, 2017 meeting, Wexner Medical Center Board

Mr. Syed:

We do have that data as well. We are seeing a bit of both. We are definitely seeing people that are leaving the academic environment to go into community based practice, but there are definitely a number of them that are going to academic centers across the country.

Dr. Drake:

It is a very great point.

Dr. Kent:

I think that is information that we need to have and we have looked at that fairly closely. As Mamoon suggested, it is a mixture of individuals leaving for other academic institutions as well as individuals going to our competitors around Columbus. We devoted a college council to recruitment and retention last week. All of the chairs spent an hour and a half talking about best practices in terms of recruiting people and retaining them. This is a major area where I think we need to focus. It requires improvement of our culture, one that is focused around academics and compensation. I think if we can tackle both of those, we will have a great deal of success.

Dr. Retchin:

Thanks, Mamoon. I am just going to cover the next couple of sections and get down to some areas we are working on.

As you can see patient satisfaction on the inpatient side or HCAHPS (Hospital Consumer Assessment of Healthcare Providers) is doing well and is exceeding target. On the outpatient side we continue to focus our efforts. In part, the yellow is because the bandwidth is exceedingly narrow, but we continue to press on that, particularly in the areas of timely appointments and we think there is a lot of room for improvement there. We can talk about the inpatient visits as well. On the community health needs assessment, this is done in conjunction with the Central Ohio Hospital Council that I sit on. We are working on a plan as part of our charge for the community and then lastly the *U.S. News and World Report* rankings that are not out yet.

If you have any questions please stop me.

On the quality and safety you can see our readmission rate continues to yield results. Those results are quite impressive among academic health centers. On the mortality rates, Susan do you have a comment on that?

Dr. Moffatt-Bruce:

We ended the year at .80. We are at 0.81 now as a system, so just a touch up. We had an increase early on in the year, but we actually increased in our UHC rankings from 16th back to the 12th position. We are starting to see a nice downward trend across the organization. We are looking at some opportunities in November, but we have taken a very aggressive stance looking at quality and documentation across the entire organization. I am hopeful that we are on track to meet our goal as we have set forth here.

Dr. Retchin:

Thanks.

January 25, 2017 meeting, Wexner Medical Center Board

Dr. Drake:

What is different from two years ago?

Dr. Moffatt-Bruce:

Every year they recalibrate the goal, mostly to include some additional risk factors. They are now including patients that have had more long-term care. They are also including some of our immunocompromised patients, which they had previously excluded from the risk modeling. As they update the model every year, they are looking at more variables to actually make it more inclusive of the types of patients that academic medical centers take care of. What I can see from looking at the new variables that were just released to us last week is the inclusion of the immunocompromised patients, which is a very broad spectrum of patients.

Dr. Drake:

I will say for those who do not come to all of our meetings, if the observed to expected ratio were exact then you would have a 1.0, so that would be predicting what you should see. Anything better than 1.0 is good. You are seeing fewer than what would be expected. We were at 0.65.

Dr. Moffatt-Bruce:

Yes, 0.65 in the old model. If you fix that it would be 0.78. Every year they change it so we are trying to look at apples to apples.

Dr. Drake:

I want to make a point and say that if you change the criteria, then you would change the old numbers as well. It is not like it has gone from 0.65 to 0.81. There are new people included now that were not before. It looks very red here. I just want to be sure we were not comparing apples with oranges.

Dr. Moffatt-Bruce:

It is very hard to look at the past because every year they include more variables.

Mrs. Wexner:

What can we do to make sure we are staying focused on the patients?

Dr. Moffatt-Bruce:

Through to the end of November, that would represent 23 more patients died than what we had predicted with the goal of 0.77.

Dr. Drake:

With a different look at Abigail's question, but compared to 1.0, what would it be?

Dr. Moffatt-Bruce:

I would have to do the math.

Dr. Drake:

That is another thing to look at with how much better we did. You can do the math and we can talk later.

January 25, 2017 meeting, Wexner Medical Center Board

Dr. Moffatt-Bruce:

Thank you I would appreciate that. My MBA would come into effect there. Dr. Retchin, would you like for me to speak to the next one as well?

Dr. Retchin:

On the PSI-90 (patient safety and adverse events composite), which we have gotten some results and there are some areas which we are working on, you can make a brief comment on that.

Dr. Moffatt-Bruce:

Of course. Just like the mortality, every year they change the goalpost for the PSI-90. Just a reminder that PSI-90 is a composite of what used to be six but it is now nine different safety metrics. They just released this last week as well. We ended last year with a PSI-90 score of 0.73. Today, we are at 0.74, but that is true only through the end of September because this is Medicare data and there is always a delay. When I look projected, we will hit our target because we have had such improvements in DVTs (deep vein thrombosis), blood clots in the legs in September, October, November, and December. Again, we have to break down each one of those categories. They changed the goalpost, we are managing each one of the metrics, and we are favorably impressed with the improvements that we have made in the last three months that are not reflected here with that .01 increase. Does that help Dr. Retchin?

Dr. Retchin:

It does. Thank you, Susan.

Moving on, you can see the urinary tract infection rates. We are beating target. On the payment transformation episodes we are really doing well there. We are moving along and trying to approach the new payment methods for bundling. You can comment as well on where we are red, Susan.

Dr. Moffatt-Bruce:

Not only are we looking at cost, but we are looking at the value equation, which is quality over cost. When we look at the quality metrics and the value transformation for joints, cardiovascular, obstetrics, and different areas that are doing these care episodes we are very inclusive. Our quality metrics, we want everyone to get to 80% of all of them, which are inclusive of length of stay, readmission, patient satisfaction, and the quality metrics that we talk about here. Perhaps we have set the goals a little bit high, but we want to be very inclusive of all quality metrics. Every area that we are redesigning is improving. We have yet to get to our ultimate goal of having every metric and every quality indicator in the green and that is how this is reflected thus far. This is the first year for this. We are being innovative in how we are approaching this as a value proposition, as compared to just a cost proposition.

Dr. Retchin:

Thank you.

Mrs. Wexner:

I did not want to skip too quickly over, just to point out, we all had a discussion on how that had gone red and to see this go green only happens because of tremendously coordinated efforts. It is too easy to skip over those greens. That takes a lot of effort.

January 25, 2017 meeting, Wexner Medical Center Board

Dr. Moffatt-Bruce:

Thank you for that. I want to highlight the nursing care and the administration really have embraced that.

Dr. Retchin:

In fact, it was a matter of policy to allow nurses to make the decision in terms of removal of the catheter. Congratulations on that.

Anything else?

Moving on to innovation and strategic growth. The news is good. We continue to have tremendous demand at the medical center for services. You can see our inpatient admissions are beating target or are on budget, rather. The hospital transfers really shot up, which reflects the positive reputation of the medical center. Hospital transfer is a patient that is transferred from an inpatient setting or often in the emergency room in another hospital. Andy, do you have a comment on the volumes and how we are dealing with those?

Dr. Thomas:

Thank you Dr. Retchin. I will start by apologizing for that fire alarm. It was testing related to a construction project we have up on the second floor for the electrophysiology lab.

In terms of the transfers, we typically have had a baseline on a monthly basis of between 800 and 900 hospital transfers on a monthly basis. Over the last six months we have been between 1,100 and 1,200 per month. As Dr. Retchin said, that is an important part of our relationship with other hospitals in the region, but also from a financial and case mix index perspective, hospital transfer patients have at least a 50% to 75% higher case mix index than patients admitted through the emergency department. There are both benefits from a financial perspective and benefits from a reputational perspective. Also, there are better clinical cases from a teaching and research perspective. The emergency room continues to see higher volumes, which has made for some capacity challenges. You can see that the admission numbers are significantly up. Year-to-date every business unit within the system is above budget with the exception of the Ross, which is a little bit below budget. Month to date all of our business units are doing better than prior year. I would especially highlight that we have been sending more highly acute patients from the emergency department here to East, as well as hospital transfers from the outside to East. We are sending a couple of those a day.

Mr. Schottenstein:

In terms of these transfers and understanding why this is an important metric, if you could maybe elaborate a little more and touch on transfers out. In other words, do we have situations where our patients go there?

Dr. Thomas:

I would say there are less than two of those a month. It is a rare thing where someone would come here and have MediGold insurance, which is only covered at Mount Carmel, we might transfer them there.

Dr. Retchin:

It could be behavioral health.

January 25, 2017 meeting, Wexner Medical Center Board

Dr. Thomas:

It could be behavioral health and that is a citywide issue where each emergency department in the city works together on a daily basis to get the patients into a bed anywhere.

Dr. Drake:

I would just like to redirect for just a moment to make sure we are clear about what we are saying. The hospital transfers, to make it straight forward, are if patients are sick enough that the hospital worries that it cannot take care of the patient. It is a tremendous service to the region. It is one of the reasons why we are here. First, it is a tremendous service to the region and second, when you look at the volume of hospital transfers, that really does service the whole region and the fact that our mortality is 20% better than predicted, it is a really great contribution to the area. Those things work hand in hand.

Dr. Thomas:

Over the past year, we have had over 12,000 transfers that have come from just under 200 hospitals, but 31 of those hospitals represents 73% of the transfers. There are core key partners, some that send us a handful, and some that send us one or two and those are the ones that come from the far reaches of the state or out of state and they may send us just one or two. We do have core key partners in our health network that we work with all of the time.

Dr. Retchin:

Any other questions?

Mr. Wexner:

I am curious about the 50% increase, why? Statistically it is so large.

Dr. Kent:

I think that the number of transfers that you get from the surrounding region is a major strength of your academic institution. Because we provide a type of care that cannot be provided in the region, so that suggests that many of our programs in fact are growing in strength and reputation, people are coming here because they cannot get that care anywhere else. This is something that is very positive.

Dr. Drake:

It is very, very positive.

Dr. Retchin:

I also think it reflects something that you have been mentioning. We are increasing capacity. Instead of turning some transfers away or not being able to get them in the hospital we are opening up beds and getting to it, but also the patient flow. The demand is there.

Dr. Drake:

The fact that patients do well and the fact that we are responsive to the people who are doing the transferring makes it a good relationship. It is a very healthy and positive partnership.

Dr. Thomas:

I would agree. I think from Gail's group that does the outreach coordination with the hospital to our physicians communicating back on the electronic medical records side, we now have a number of hospitals that we are selling our electronic medical record to and that makes it easier to respond to those things. For those that we do not sell Epic services to, we have a service called doc link where referring doctors can see what happens to their patients when they are here even if they are not on our medical staff. Across the board improvements have really helped. To Dr. Retchin's point, if you look at transfers when someone called us and we said we do not have a bed today, we have cut that percentage in half and we still have about two per day, which is more than we would like to have, but at the same time it used to be about 8% of those transfers we just had to say I am sorry we do not have room today. That is now down to 3% to 4% a month. Part of that is the growth in the denominator, but the number of cancelled transfers is still about the same but we are doing better at providing access.

Mr. Wexner:

With the number of increase, I am guessing that would cluster either by source of referring hospital or practice, or something. There is some pattern. I accept the fact that we are better so our reputation helps us, but is it clustered out in any categories?

Dr. Thomas:

Before getting into specifics, we should probably do that in executive session. I do have that data and can share that with you if you would like?

Ms. Marsh:

I will add in public session that our philosophy is to help these hospitals across the state to provide safe services there in their own facilities as much as possible. We are helping patients stay in their community with their families at the same time the number of transfers are moving. We have put telehealth in 26 hospitals, but when the patient can no longer stay there, they will then send that patient to us. We are not just sitting back waiting for them to come to us. There are real initiatives across the whole state by helping them become stronger healthcare providers.

Dr. Retchin:

Before we leave this, I want to underscore that the faculty, nursing, pharmacy, and therapists really deserve a huge amount of credit. Continuing to work together and collaborate and building the reputation, and also servicing and communicating with these hospitals that are transferring, it is a great job. It is a great story. Continuing on, I am going to drop down to new patient visits, which continued to not quite reflect yet the increase we have in new facilities which we know will kick in. I do not see Dan Like but I wonder, Andy, if you have any comment on this.

Dr. Thomas:

We are certainly seeing that as we open both Crane as well as Upper Arlington and then certainly looking at more specifically how to backfill some of the space of people that have moved to Crane. I think we are looking in behavioral health to backfill some of the space here on campus that psychology had moved out of to move to Upper Arlington. It is still an evolution and process. Our primary care clinics have also all received CPC Plus (Comprehensive Primary Care) designations from the federal government in terms of their quality and risk payments so I think we're continuing as we recruit more people to see demand that we have not yet met and we will have room to improve.

Dr. Retchin:

Which is again, going back to our satisfaction on the outpatient side, it's timely appointments and so we are in a growth mode which is great news but we've been discussing that with department chairs and faculty and need to do some recruiting and expand our capacity. Lastly, you can see the NIH (National Institutes of Health) awards are close to being on track. Craig, do you have a comment about that for the College of Medicine.

Dr. Kent:

I think we are launching a growth mode or a curve for research and it takes time to put the infrastructure and efforts in place but, a couple of examples: one, we're in the midst of reorganizing our research infrastructure with some new leadership and some new people and initiatives. I think that is going to help significantly. The other initiative that we have is that we are putting together a team of researchers to develop a strategy. As you all know, we can't be great in everything and we have to pick and choose what areas that we want to have success in. This team is going to help guide me in terms of our recruitment, retention, and the types of programs that we want to have. I think we will see that number grow over time.

Dr. Retchin:

Excellent. Questions? Maybe we will move down in a minute in terms of our submissions to the NIH, we will get back to Dr. Kent. While you are up there, Andy, on the inpatient length of stay, that has turned actually yellow I believe as of December. We are continuing to make headway in terms of length of stay and improving our capacity. Do you have any comment on this?

Dr. Thomas:

I would agree with what you said. The patient population we focus on the most to improve length of stay are people who are not going home, people that are going to some sort of a facility where an insurance company needs to pre-certify them to go to a rehab facility, to a long-term acute care facility. When we look at our expected length of stay for patients that are going home, especially those who don't even need home health services, that's about 60% of our patients, we do quite well, in terms of getting those patients out in a timely manner. However, Anne and I were just discussing this this morning, there are a lot of process issues around insurance approvals that we will still continue to work on, meeting with post-acute providers on a quarterly basis to have them be more ready to take our patients in a quick fashion. There is still room to improve and it is nice to see the metric not be red but at the same time, we still think there's additional improvements to make. Some parts of the medical center are doing better than others.

Dr. Retchin:

Continuing on that same vein on our access, we had some improvement in primary care but still, some pretty long wait times on specialty care and we're working on those. Andy, comments?

Dr. Thomas:

That goes back to my comments before, we're still in the recruiting mode and growth mode and I think we are not going to see, maybe even another year, some of these metrics to get where we want them to be, but they should continue to improve during that time. I would say that the emergency department metrics would fall under the same category. When you think about the same sources of patients we've talked about, there are people coming in for surgery or procedure, there are people coming in through the emergency department who are coming in from outside transfers. Unfortunately, part of

our growth has been a growth in emergency department visits but with capacity that has more beds to come online in the next 12 months, we are still seeing backups in the emergency department. I think the good news story, and Dr. Retchin and I talked about this a little bit last night on the phone, is if you take out people who are in the ER waiting for an inpatient bed, and look at the people coming through, we are beginning to see some improvements in the ER process itself, getting labs drawn earlier, getting the patient assessed earlier, they're making some renovations later this Spring which will help. It is a full on team effort with ER leadership, the hospital leadership, and the medical staff leadership to try and get these processes to work better but until we fix the boarding in the emergency department, that number will not show the big improvement that we need to get to the goal.

Dr. Retchin:

Through the medical staff process, you are actually working on some areas where really up on the involvement of our faculty directly in these decisions.

Dr. Thomas:

Yes, we've had a couple of meetings with the chairs and medical staff leaders. The most recent one was a week ago Wednesday, sorry, two weeks ago Wednesday, two weeks ago today, where we had a terrific discussion. I think we made more progress than I even expected to make culturally in the discussion, in terms of certain services that wanted to control the flow of patients to them and wanted medicine to admit a patient, or a general surgeon to admit a patient, we've a lot of, I think, cultural improvement, but it is a day-to-day effort to continue this communication. That was an impressive conversation though with the chairs and I just saw a real radical cultural change that was great. NIH submissions, Craig, we're still tracking on that and you're working to increase those with our faculty.

Dr. Kent:

Yes. We need to put the infrastructure together and start our new initiatives.

Dr. Retchin:

We will talk more on the financial performance but, sea of green, which is appropriate for the color, and maybe that is a nice segway into your section. Any questions or comments on the scorecard in general?

Ms. Vilagi:

Dr. Retchin, under productivity and efficiency, do you measure the average length that you need to get an appointment for an already existing patient? So, I'm not a new patient, I'm an existing patient, what's my average wait time for a follow-up appointment?

Dr. Retchin:

Yes, we do, Andy, I don't know if you want to comment on that. Those are probably reflecting about the same thing in terms of wait time, and of course, on a return patient, it's a little more difficult in terms of deciding between acute need to be seen versus routine scheduled appointment three months from now. Although, it has a different type of meaning.

Dr. Thomas:

There is a wider range in terms of what you would expect it to be because some people need to be seen every month, every three months, every six months. Trying to figure out what the benchmark would be, we do track it and for the most part, those visits are

shorter, they are easier to schedule. It is new patients, where, obviously, we've not seen them before, we really don't want to not have the opportunity to assess what they need in a quick sense but from a scorecard perspective, this is more meaningful.

Dr. Moffatt-Bruce:

The quality metric would be the CGCAHPS (The Clinician and Group Consumer Assessment of Healthcare Providers and Systems), right? The timeliness of follow-up, the timeliness of your test results, that's the outcome metrics, what you're asking is a process metric, we're looking at an outcome metric which is something that I think we need to improve on and we have opportunities.

Dr. Drake:

I am going to raise a question and I want to make sure that we are focused on it. The role that we have in the world is to be a place to take care of patients that are particularly challenging and that's the center of our focus. That really was reflected in the transfer number and these tend to be complicated patients that come by ambulance of other things. They can be very sick, there's lots of communication, that is a big and busy part of what we are doing. They tend to have, as Andy said, have much high acuity scores and the case mix index is very much different from patients that we would see through our normal admissions procedures. Just know that those are complicated patients with complicated problems that are coming with urgency to make sure that things are okay and it's a real service to the patient, the patient's family, the other hospitals, and the community. I do not want to deemphasize the focus that we have on those things and how important that is to us.

The second thing is, I am one that thinks the wait time for new patient appointments, I always use third appointment rather than first because the first can be an anomaly. Maybe we will change that as we go forward but that's really something we need to focus on because if somebody has an issue or a problem and they need or want care or a service, and if it's six weeks or two months, that's not reasonable in any way. That is like not being open in many ways. One of the things that puts such pressure on that is the focus on return appointments from one's own panel so if you are seeing somebody on a Monday and you think this person needs to be seen in a month, the you schedule that person to come back in a month and the fact that you are seeing patients between now and when that first new patient appointment was available and those patients are scheduled to come in after that and filling in slots, means that you get full. That is why it's a very difficult thing to chase because your current patient population and their return visits fill out in front so that the new patient appointments are really difficult so you wouldn't wait for three months for a one month appointment because that would be scheduled in as a priority and then that would push everything else back. Andy is going to make a comment.

Dr. Thomas:

I am going to make a couple comments along those lines. I think one of our goals is to better utilize advanced practice providers for some of those follow-up appointments; so nurse practitioners, physician assistants, and many of you have had this experience where you may go for a follow-up appointment with a surgeon and see their NP (Nurse Practitioner) or PA (Physician Assistant) and only if there is an issue, they pull the surgeon in. If everyone is doing fine, you're there to get your stitches removed, you may see the surgeon for 30 seconds but it's really using that team of providers in a more effective way for follow-up appointments. The other thing I would state is that if you looked across all of our sites, there are some sites that are doing this incredibly well. This is an average number so I think some sites have really prolonged capacity issues and others are doing well. This is really a balanced number of the system but I don't want you to walk away from this discussion thinking that, on average, all of our sites

don't do well. A lot of the sites do very well with new patient appointments and some have varied challenges, and this is an average.

Dr. Kent:

I would add that I think there is incredible room for improvement. We have been working very actively in the physician foundation to try to solve this using a number of different approaches. One of the problems is that we don't have enough physicians. We now are in the process of recruiting 150 new faculty members and not until we are able to recruit these individuals, are we really going to solve this problem. We are creating more efficiencies in the clinic and I think that will help and I think the use of advanced practice providers is going to be something that is very helpful for the follow-up visits. If we put all three of those together, give us a little time, I think we will solve this.

Mr. Schottenstein:

Just a question about the scorecard in general, I understand it is just a tool and maybe there have been discussions about this in previous meetings. It is difficult for me to look at some of these items, whether they are green, red, or orange and know what it even means. You know, when I see 21 days or 344 minutes or .58, I mean, I don't know whether to celebrate or to close up and I just wonder what the process is for setting targets, how to provide, at least for maybe Board members or at least me, context, how these relate to where we hope to be in two years, three years, five years. You know, we are who we are, and there is a path and I'm just wondering. I know we're not going to have that discussion right now and maybe the discussion has already occurred but it's difficult to react to some of these or to know how to even think about them.

Dr. Retchin:

It is a terrific point and spot on, we have talked about this, but so as part of strategic planning, there's kind of a column missing and Mr. Wexner has brought this up a couple of times and that is, not only where the target comes from but where are we going to be a top ten, top twenty. We talked about this, I guess this week as well, being able to annotate that so that there is some more meaning, not only on what our targets are but where the top places are and some of these targets do reflect top ten, top twenty, but we need to be more definitive on that. You are exactly right. Any other team members? Gail, do you have a comment on that?

Ms. Marsh:

Last meeting, the board asked what's best in class in each of these variables and I know that the management team is looking to define that for each variable and build it into the strategic plan and then monitor against that as well, not just the annual goal.

Dr. Retchin:

Abigail, you have brought that up as well so we are going to work on that. It is a very good point.

Mr. Jurgensen:

I think the fact that this scorecard has as much red as in many places as it does, it's actually a good thing. I think about all the other scorecards across the university that tend to be 99% green all the time, it just suggests that either the bar is not high enough or we're not measuring the right things but you know, red is an opportunity to get better and as long as the red, I think management knows the difference. They know which reds are more important than others but the fact that we have as much as we do on this card, actually tells me that this is probably more accurate scorecard than we have a lot of other places in the university.

Dr. Drake:

One of the things that is great and reflective of this, is a couple years of this, it is second nature, I think, but is that really over the last generation, last twenty years or so, since the mid-90s, hospitals in particular have been using outcome measures to compare themselves. Starting in a very narrow way, but expanding and becoming much more textured. There is a general view in the world of what is possible, what you can do, where you can improve, and very tight focus on trying to be as good as one can be and that is why the yellow, red, green can be a few basis points even, because you say, gosh best in class is this or of this many thousand people, we'd have this many things happen; we'd like to move to that point and we then really notice that when we're not moving that way. One way, we are looking at an entire hospital with thousands and thousands of inputs and the numbers are really terrific. Another way each little tiny input is somebody doing better or not and so it makes a whole lot of difference to be able to look at this level of granularity and compare ourselves with similar facilities around the region and around the country. It really has helped everyone get better and better as the years have rolled on, so it's a good measure and a good way to help us look at ourselves.

Dr. Retchin:

I do appreciate Jerry's comment on that and I do want to caution the team that that is not an invitation to turn more red but I think the conclusion on this is that we have great demand. We need to create capacity to be able to serve that demand and there are always quality areas where we are going to set the bar high but we are going to come back with best in class benchmarks and continue that process. Thanks for all those comments. With that, unless there are other comments or questions?

Dr. Fujita:

I have a question about the NIH submissions here. My question is do we have a consolidated approach to go after some particular NIH awards, you know, for some particular research area or do we just go after, I mean, each researcher goes after whatever opportunities they have? I just have a question because there are some institutions that are known for cardiac or heart diseases so there is a consolidated effort there. You know the university here, do we have some targeted area to be number one in this application, in this research? That is my question.

Dr. Retchin:

That is a great question. I will answer part of it and ask Dean Kent to also join in. I think that the answer is that the medical center, particularly the College of Medicine is intentional now and about ready to become more intentional with the strategic plan of the university which is a great launch. Clearly, we're intentional about cancer, trying to be in the top 10 among cancer centers. There are other areas certainly, cardiac, you're going to hear about in just a few minutes and an area there, and the neurosciences, and other areas in terms of basic sciences and emerging pathogens. I will just say, we try to go after areas and intentionally invest in areas where there is funding. Our goal is, that's why we look at the NIH, remember, we are not putting the National Science Foundation on here, the NIH is really always going to be the principle agency and that's easy to see where the areas of emphasis are for the NIH. That is not always true, there are areas where we get outside of that but I think that could be reflected in that.

Dr. Kent:

I think that's a good summary. Just to reiterate, we are now putting together this strategic planning group to try to figure out where those areas of emphasis are. Some will be areas where we already have strengths and some will be new areas where we want to invest. Part of the strategy is to align what the NIH is funding with the areas that we choose but there are other factors that we want to weigh in. For example, what's

January 25, 2017 meeting, Wexner Medical Center Board

important in our community. A good example is that we know diabetes is rampant in the Columbus community and throughout Ohio so we've just recently launched a major initiative with five new recruits around metabolism and diabetes. That would be a good example but much more to come as our strategic planning process moves forward.

Dr. Wadsworth:

Could I comment, if I may? In response to Dr. Fujita's question. You know, some years ago we made a major effort to convert assets into cash for investment and the Discovery Themes are part of that but there was also a very deliberate notion that we would invest heavily and asymmetrically to drive the university to be number one in several areas. I think at this board meeting over the next couple of days, we are revisiting the R&D (Research and Development) strategy but I think it is a work in progress as to whether we have yet determined how to spend that money, in order to have impact that drives us to number one. Just as an aside, I was very pleased to be invited by Dr. Ali Rezai to do something I never thought I would do which is give a talk on a brain at a conference in Las Vegas last week which he had organized. There were 2,500 people there, very impressive, you know, so the question is does that rank and are we going to make some asymmetrical investments to drive ourselves forward. I know there is a strategic plan underway and that should guide us. Some of these investments though were created four years ago and I think we're still struggling with how to bring a large focus onto one or two areas to drive number one excellence. Thank you.

Dr. Retchin:

Any other questions or comments?

Dr. Lancaster:

I do have one question, if I may, regarding the back to the conversation about access and appointment efficiency. Where do you consider the data on broken appointments, no shows, because that's something that can have a big effect but it's not a controllable variable. I am sure that is something you look at but at what place is that represented on the scorecard.

Dr. Retchin:

It is something that we look at, every institution does, try to reduce the no shows, broken appointments you can anticipate, only so much, the no show rates is what we really try to get at. We actually have, maybe anybody who has ever made an appointment at the medical center, a robotic call that goes out and reminds patients, I don't know, four days in advance? Does anybody know?

Dr. Thomas:

Two days. It text messages you as well.

Dr. Retchin:

Yeah, a very pleasant voice to remind you. We need to work on the pleasantness it sounds like. That is actually a great question because it reduces your productivity because then you have down time. We work on that. Any other comments from the team? Any other comments or questions? I am going to turn it over to Mr. Larmore for the financial summary.

(See Attachment XII for background information, page 201)

Mr. Larmore:

Under the tab called financial summary, pleased to go over the December numbers halfway through our fiscal year and as normal, I will talk about health system performance starting with hospitals first and then I will talk about the medical center which will include the physician practice and the College of Medicine.

On page two, on your deck, you can see, although we talked about too much green, from a finance perspective I am happy there is a lot of green. I think on admissions halfway through the year we're running ahead both on budget and on prior year. Our surgical volume which is very important and drives a lot of our, it is a good measure of our intensity of our average patient, you could see both as positive and as prior year. We came out of the blocks this year a little slow on ambulatory but we're making up ground. We still show growth year-over-year but about 3.8% behind budget. We have seen the last two months have good numbers there. I think the box in the bottom right is where if we look back on the prior board meetings, we struggled a little last year on this and controlling the number of worked hours per adjusted admission. We have that down below our budget in our prior year levels which is a good sign of expense controls.

On page three, on an operating revenue basis, we're ahead 0.6% of what we had projected and 6% over last year. Our controllable costs we're just slightly overspent about \$4 million. I'd attribute that to having a large increase in drug spend this year which some of that shows up in our revenue numbers. On the medical surgical supply when you see the actual numbers, growth in our prosthetic devices so we've seen a growth in our orthopedic volume and our cardiac valve volume and there is a cost of purchasing the prosthetic to do those cases. I would expect it to grow year-over-year but 9.2% is a little higher than I would like to see. On the excess of revenues over expenses, we're 3.8% ahead of budget and remember, the bottom line doesn't come through as we go through the year. There are certain months that seem to drive more volume for us so we're ahead of budget over prior year and we're about 13% behind prior year and we are monitoring that. I feel comfortable where we stand and that will meet our targets for year end. Days cash on hand stayed consistent at 114 days. That might not make logical sense because cash actually increased from \$674 million to \$711 million but our average cost per day went up; as our expense base grows, our cash balance needs to grow to keep up with the same day calculation. Good results on the two flash slides.

On slides four, five, and six, I've given you because we closed three months since we had the prior meetings. My plan was not to go through in detail each month but to just comment on each one then then I'll talk on where we are year-to-date. October, from a bottom line standpoint, at about \$700,000 favorable to our target. You can see a little short on the revenue side but good expense controls in the month so that offset the revenue shortfall. On slide five is November; November was an unusual month for us. We did have good volume and hopefully that is the start to a trend that we are seeing in December and January also. It is a good volume, good surgical volume, 186 positive surgical cases in November. You do see on the salary and benefit line a \$5 million overspend and this relates to the fact that we were bringing the Brain and Spine Hospital on board and as we bring staffing on, especially on the nursing side, we have an increase in hiring and we are bringing those new employees through our orientation process. On the nursing staff this could be eight to ten weeks of overlap with an orientee and a nurse, as we expand, we expect some blips on the salary spend there and you will see in November that that cost actually came back in line. Although we did have that blip on salary spend because of the good revenue month, we were ahead of our target in the month of November. Slide six is December, you can see a \$1.5 million positive to our budget in the month. A good revenue month, \$1.2 million to the good and I would say, overall, good expense controls. You can see the salary and benefits came down from \$5 million to a little under \$500,000 overspend which is good. We adjust depreciation as we bring projects on during the year so we're actually bringing more projects online, capital projects than we had expected so the depreciation expense is running a little ahead of what we had expected.

Slide seven is where we stand for the first half of the year. From a bottom line standpoint, we're at just about \$85 million expected to be at \$81.5 million, so \$3 million positive to budget and about \$13 million behind last year at this point. The revenue numbers are \$7.8 million to the good and then on the expense side, a couple of categories, I spoke about the salaries, it really is that one month blip in November that is driving that and then on the supply side also, I spoke about the overspend there for the two areas, our predominant spend there. The one I didn't mention in that was transplants, our transplant volume is running considerably ahead of last year which is good news but we actually have to go procure the organs and there is a cost to that. As that volume grows we will see it in the revenue from the cases but we also see the expense come through over budget.

Ms. Krueger:

What is the thinking behind planning the excess revenue over expenses so far behind last year?

Mr. Larmore:

As you can see in the budget, we knew that we were going to take some adjustments to our government rates this year. We had the state rebase Medicaid this year and we're taking a reduction for that, we had some change in allowable items on our cost reports, dating back to fiscal year 2015 so we have three years of impact. It was a provider tax that we pay, or a franchise fee, and we used to be able to allow that as a reimbursable cost and they decided to disallow that in fiscal year 2015. We find that out this year and it is kind of an unusual business that they can change retroactively so we're absorbing the impact of that change, over three years, change this year so we're seeing that. I would say those are probably the biggest impacts, again, from a bottom line standpoint, our budget was north of \$200 million so it doesn't come through evenly, the second half of the year from a budgeted bottom-line standpoint is always higher than we expect so that plus the capacity that we brought on already this year to still perform positively for the year. So any questions on six months to date from the health system standpoint?

Slide eight is the medical center which includes, as I said, the physician practice and the College of Medicine. Both of those are doing very well so the positive variance increases here so when there are \$106 million, almost \$107 million with a budget of \$82 million, so \$26 million ahead of budget and about \$10 million behind last year; driven all by the health system which I talked about. You can see from a revenue standpoint, \$24 million to the good and \$2 million on total expenses so good news through the first half of the year. Then the adjusted admission just below the line there, 2.2% ahead of budget over that adjusted admission account is an averaging of your inpatient and outpatient volume to create a consistent statistic.

Page nine splits the P&Ls (Profits and Losses) by the three companies so just the middle categories you can see the variance against the budget. I spoke about the health system at \$3.1 million positive. The practice plan is running about \$4.8 million ahead of our budget and is actually running 1.2% ahead of where we were last year and the College of Medicine is running considerably better than what we had projected at this point, \$18 million ahead of our budget and about \$2 million ahead of last year. Remember, the College of Medicine is on more of a cash basis and to the extent there is a lag in capital spend or a lag in grant dollars coming in, it's a little more variable than the health system. We've kind of brought out a cash basis, maybe a little bit of a modified accrual, in that we are actually spreading some of the things like tuition and financial aid across the year and not showing them only one month.

January 25, 2017 meeting, Wexner Medical Center Board

Mr. Schottenstein:

Since the College of Medicine accounts for such a large portion of the year-to-date total system variance, does that mean because that levels out the amount by which the total system is ahead will compress?

Mr. Larmore:

Yes, I think. Slide 10, shows you just the first six months for the physician organization which is the \$4.8 million positive variance on the bottom so revenue is running \$1.4 million ahead of our target. We have, you can see, pretty positive variances on physician salaries and non-physician salaries. We have not recruited up to the level of incremental faculty this year that we had built into the budget. The staffing that comes along with new recruits has not happened so it is driving the positive variance there, but we would have built in anticipated revenue for those new physicians coming on board. It is good news that we are actually running ahead of our target without recruitment at the level we had expected.

Slide 11 is the College of Medicine. It is running \$14 million positive to where we thought we would be this year, which is a big number. The college does record spendable gifts. In December we had a good fundraising month. \$3.8 million of that variance is attributed there. Our research funding is about \$1.5 million ahead of our budgeted number. The earnings on our endowment are \$1.3 million ahead of what we had expected. The amount of funding that is provided from the practice funds and the deans tax fund towards running academic activities is running about \$4 million ahead of what we had projected. Out of those items, the fundraising in December will not repeat itself in the second half of the year. That is usually our best month in fundraising. The other items are there to stay so it is good news.

On the salary side, I think out of the two plus million dollars the biggest piece there is the recruitment. We just haven't recruited to the level that we had not only on the practice side but also on the academic side we are a little behind where we had projected.

All three enterprises are doing well for the first half of the year. Slide 12 is the balance sheet. This is the combined medical center. You can see that during the second half of the year we moved \$250 million into the long-term pool at the university. Some of the assets are limited to use of the funds that were sitting there plus some of the cash. If you want to look at a year-to-date basis, I would put those two lines together. We are about \$41 million ahead of June 2016. The only other one I will comment on is the long-term debt that we have paid down \$25 million in six months. That is about a \$50 million run rate on extinguishing debt on an annual basis.

Those are my comments through December. I think Andy Thomas watches the numbers as much as I do and he has already talked about the positive results. If I go through my presentation and I am off a number I know that I will always get an email from Andy questioning my numbers. It is nice to have someone checking up behind me. As long as he does not ask for his salary paid by finance we will be good.

Any questions for the activity for the first six months?

Mr. Wexner:

Mark, any insight from numbers that give you a feeling about the six months ahead?

Mr. Larmore:

Clearly, it has been stated already that there is an amazing amount of demand to get in here and I think it has been there for a while. We have changed the attitude at the medical center from a conserve and cut mode to a growth mode across all departments. We are spending three full days next week meeting with all of the clinical departments

January 25, 2017 meeting, Wexner Medical Center Board

to go through what their one year, three year, and five year plans are. We are looking at the three and five because that will play into the long-term strategy that we are putting together. Then we have a number of projects underway to bring more big capacity on. That will help us on the inpatient side and then certainly the physician recruitment, which I spoke about. There is a lot of focus on that because we have to up the access to the ambulatory physician because that is our feeder. Our choice volume is elective admissions to the hospital. That is always a better book of business than what comes through the emergency room. I am optimistic for the second half of the year.

(See Attachment XIII for background information, page 203)

Dr. Retchin:

Any other questions or comments? In the interest of time so we can stay on schedule, Jay, do you want to talk about the acquisitions of property?

Mr. Kasey:

The acquisition of 2.69 acres from the Columbus Metropolitan Housing Authority was reviewed by the facilities committee and we found that we needed to review it in the context of OSU East's strategic plan and the east side PACT (Partners Achieving Community Transformation) strategic plan. Elizabeth would like to make a few comments to make sure that we understand this acquisition.

Ms. Seely:

In your packet and on the screen is the map that is showing a larger context around the hospital and this recommendation is in this context of strategic redevelopment of a near east side 800 acre geography that surrounds the hospital. That geography, as you know, is identified as a priority for the city, the university, and the Columbus Metropolitan Housing Authority. In 2010 when PACT (partners achieving community transformation) was formed and the designation of the first \$10 million of a \$35 million job growth creation tax incentive from the city to the university for housing redevelopment, education, and neighborhood improvements. That geography was designated with PACT being the community quarterback. There are a few other transactions that also support this PACT blueprint for community redevelopment including the sale of three non-strategic hospital parcels that are showed in green to the Columbus Metropolitan Library for them to build a new Martin Luther King library branch and also PACT making a grant from CMHA from the job growth creation tax incentive fund to support CMHA, its acquisition of property, and development of new housing in the area of Mt. Vernon Avenue, which is shown in blue on the map. All three of these transactions really support the goals of PACT and improve the neighborhood around the hospital. This purchase in particular is an important strategic initiative for the future flexibility of the hospital as we look 10 or more years down the road and we currently have fully utilized buildings of an age that will ultimately require replacement in order to maintain the high quality services that we are providing in this location. Not being land locked will give us future flexibility to plan for and execute facility strategy in conjunction with a long-term strategy for this very important community asset. The purchase has received endorsement from the facilities group, which did review it in depth after the last board meeting.

Dr. Retchin:

I think we need a motion to approve. Is that right Heather?

Ms. Link:

We can bundle it with the next one and do them at once.

January 25, 2017 meeting, Wexner Medical Center Board

Dr. Retchin:

Thanks, Jay. Before we turn to the next one, I will ask Bobby to introduce it.

Mr. Schottenstein:

Thank you, Dr. Retchin. I appreciate that. This next item relates to Cannon Drive, which I know is just a road but it is a very significant one. Issues relating to the relocation of Cannon Drive, though I am new to this board, are not new to me because they have been in discussion at this university for many, many years. In many ways, it is one of the most significant land planning endeavors that we have on the east side of the river. I think it is important and it is exciting.

It is a project that will proceed in partnership with the city of Columbus. It will be done in phases, but once done will accomplish a number of very important things. One by moving and elevating the final level of pavement of the roadway, a levy will be created that will effectively adjust flood lines and protect existing university medical center buildings from possible flooding, but as a result of the relocated flood line from the elevation of the new road as the road gets relocated to the west it will open up close to 12 acres of new land for possible future development. This new land will be on the east side of the newly relocated Cannon Drive.

As part of the project long term, there is a lot of aesthetic improvements that can really help unify this part of the campus. The Olentangy River corridor will get a new park and part of this design will ultimately call for a heavily landscaped boulevard with appropriate trees. I think there is a real opportunity to make this road a really nice parkway. I do not want to oversell it, but I think it is important to understand the opportunity. Perhaps, most significant from an access standpoint, once Cannon Drive is ultimately relocated and completed, we will have a north and south connector besides High Street. Years ago, Neil Avenue used to go all the way through and it does not any more. We know it is hard to get from one end of campus to the other. Opening up Cannon Drive from King Avenue all the way to Lane Avenue, it is probably hard to imagine what that could do in terms of relief and traffic movement. I think that we are at the beginning of a construction project that has been in discussion for seven years. I think that is an exciting thing.

In terms of some of the specifics, before I turn it over to Jay. As a result of the relocation the new road is going to pass through some of the existing parking lots. There are roughly 2,000 parking spaces there. There has been a long, thoughtful process to evaluate alternatives to the polo lots to meet the needs of those that park there now. Jay will talk about that a little bit. The improvements that will take place over time, which Dr. Retchin referred to a few minutes ago, include new shelters, a bus loop, and a transit center. I think it is very exciting. While this relocation of Cannon Drive first was imagined many years ago, it totally aligns with the Framework 2.0 as well as the strategic goals of the Wexner Medical Center. Last point before I turn it over to Jay, where he will talk about the 15 different preconstruction enabling projects that are necessary before hard construction of the relocated road takes place, these projects add up to just slightly in excess of \$16 million. One time it was contemplated that as part of the relocation of Cannon Drive is that we build new garages. We can debate until the end of the days whether or not we need more parking garages on the campus. We are not going to be building these garages at this time and that is a savings, at least in the short term, of somewhere between \$50 million and \$75 million. I think that in terms of context and understanding what we are trying to do, I think that this is a really smart plan. I am excited to turn it over to Jay.

Mr. Kasey:

Thank you, Mr. Schottenstein. Let me say that the facilities committee has really been hard at work and working through the details and what we are trying to accomplish here. I will not go into what Bobby has said very well; the vision of trying to move Cannon

Drive and all of the advantages it brings to both the campus and to the medical center. I will just talk briefly. This is a big deal and it has been a long time coming. You will remember in November, this Board of Trustees approved the construction of Cannon Drive and since that time we have been trying to make sure to keep ahead of the construction by getting all of these enabling projects put in place. The thing that I would point out in addition to the really great comments that Mr. Schottenstein made is that we did examine more garages on the core campus, more surface on the core campus, and more surface parking on west campus. Following a big evaluation and lots of pros and cons, our leadership teams agreed that we should move toward surface parking on west campus and an outstanding shuttle program that will move our employees and our staff back and forth very efficiently. I will just point out a couple of things that will be new and will be immersed in the culture of the medical center. The Carmack lots on west campus have the capacity to accommodate the medical center and can support the sufficient and timely shuttle service that we are describing and will be less impacted by events for parking. Improvements on those Carmack lots include new shelters, new bus loops, as well as access roads that will be built into those lots so that the lots can easily fill and exit after peak times and shift changes. We will be using 13 shuttles during peak times at the Carmack lots to transport our staff from west campus to a new transit center, which will be located on John Herrick Drive. Those shuttle transfers will be about eight minutes in length. There will be about two minutes to fill the buses and exit buses, so we think we are looking at about a 12 minute turn around time and there will always be another shuttle waiting as one fills. There will be a covered walkway extending from John Herrick Drive, where the transit center is to 12th Avenue, which is the back door to Doan Hall and Rhodes Hall, so that people will be out of the elements. Let me say that the transit center itself is still in some state of design, but it is organized so that we can keep buses out of the core of the medical center campus and yet have a very quick and adjacent walk for people coming in and out of the medical center. It should greatly decrease the amount of traffic during this very hectic construction period that we will go through for two years. There will be a chance following the completion of Cannon Drive to reevaluate if there are other surface lots we could develop or if there could be another garage in the future. At this point, we believe it is important that we just have these surface lots on the outside of the medical center, in general.

Dr. Drake:

The really exciting thing, as Bobby said, is that this is a project that has been envisioned for years and it is critical for us moving forward and expanding and modernizing the facilities that we have. We had a talk a little bit ago about how our capacity is so impacted and we have great services that are in great demand from the entire region. Our efficiency and our effectiveness are compromised by us having the space to do that in an effective way and being able to add 12 acres of space here in the core campus so we can then develop according to strategic plan as outlined in Framework 2.0 is really a critical thing. This is a tremendous opportunity that is coming forward with everyone's efforts.

Mr. Shumate:

I would also like to echo that sentiment because there has been excellent work by the facilities committee and the university as a whole and this board. I think it speaks very highly of the alignment that we have with our overall university strategy and the strategy of the medical center. That Framework 2.0 allows us then to properly evaluate individual projects like Cannon Drive and be thoughtful and forward looking in our analysis and evaluation. I commend all of you who worked so hard over the past several years on the Framework 2.0.

Dr. Retchin:

I would like to ask for a motion to approve both of these projects.

January 25, 2017 meeting, Wexner Medical Center Board

Mr. Kasey:

I would just like to say one thing. I want to thank Gail Marsh and her planning team and the medical center leadership team with Dr. Retchin has really had a very high bar on this one and helped us get there. Keith Myers and his team also did a wonderful job.

Dr. Retchin:

Any further discussion?

Dr. Wadsworth:

Yes. I have been working very closely with Jay, and Bobby Schottenstein knows all about this, but there is going to be a major construction change south of 5th Avenue, between 5th Avenue and 3rd Avenue. The movement of Cannon Drive affects the Battelle entrance, so we are probably going to move that and there will be a lot of construction over the next few years on the land we have sold south between 5th Avenue and 3rd Avenue. That is all great and we have working very closely together and there are no objections or issues except it does complicate traffic flow. We are working with the city so there is going to be a lot going on between north and south of King Avenue. We have been trying to think about parking a little bit with Jay and it is a good relationship.

Dr. Retchin:

Great point. Any further discussion or comments?

ACQUISITION OF REAL PROPERTY
Resolution No. 2017-50
NEAR UNIVERSITY HOSPITAL EAST
COLUMBUS, FRANKLIN COUNTY, OHIO

Synopsis: Authorization to purchase real property adjacent to University Hospital East bounded by Hawthorne Avenue, Hughes Street, Phale D. Hale Drive, and the planned extension of Winner Avenue, Columbus, Franklin County, Ohio, is proposed.

WHEREAS The Ohio State University seeks to acquire land, owned by the Columbus Metropolitan Housing Authority (CMHA), located on the near east side of Columbus and adjacent to University Hospital East to support future hospital expansion and/or facility replacement; and

WHEREAS this purchase supports the university's vision of enhancing the quality of life on the near east side by creating a healthy, financially, and environmentally sustainable community where residents have access to safe and affordable housing, quality healthcare, education, and employment opportunities; and

WHEREAS this vision is shared by Partners Achieving Community Transformation (PACT) and the project is consistent with PACT's Blueprint for Community Investment plan.

WHEREAS all costs associated with the acquisition of the property, maintenance and repairs, and any improvements will be provided by the Wexner Medical Center:

NOW THEREFORE

BE IT RESOLVED, That the Board of Trustees hereby approves that the president and/or senior vice president for business and finance be authorized to take action required to effect the purchase of the referenced property, in the name of the State of Ohio, for the use and benefit of The Ohio State University at a purchase price within ten percent of the

January 25, 2017 meeting, Wexner Medical Center Board

appraised value and upon terms and conditions deemed to be in the best interest of the university.

(See Attachment XIV for background information, page 209)

**APPROVAL TO ENTER INTO/INCREASE PROFESSIONAL SERVICES
AND ENTER INTO/INCREASE CONSTRUCTION CONTRACTS**

Resolution No. 2017-51

**Approval To Enter Into/Increase Professional Services And Construction Contracts
Transportation Plan Implementation**

Synopsis: Authorization to enter into/increase professional services and construction contracts, as detailed in the attached materials, is proposed.

WHEREAS in accordance with the attached materials, the university desires to enter into/increase professional services and enter into/increase construction contracts for the following projects; and

	Prof. Serv. Approval Requested	Construction Approval Requested	Total Project Cost	
Transportation Plan Implementation	\$3.3M	\$13.2M	\$16.5M	auxiliary funds

NOW THEREFORE

BE IT RESOLVED, That the Wexner Medical Center Board hereby approves and proposes that the professional services and construction contracts for the project listed above be recommended to the University Board of Trustees for approval.

(See Attachment XV for background information, page 215)

Upon motion of Mr. Shumate, seconded by Mrs. Wexner, the Wexner Medical Center Board members adopted the foregoing motion by unanimous voice vote.

Dr. Retchin:

Thank you very much. I will introduce the next topic, very quickly. As some of you know, we started this program called the WexMed Live. This is a series of relatively brief presentations by our outstanding faculty in areas of expertise largely in research and more than occasionally breakthroughs. In a few weeks, I will be taking some of these researchers who have been doing this with Patty Hill-Callahan to Florida, where I will make a series of presentations to members of our donor community and our supporters. The reception of these has been exceptional. What you are about to see is one of those from one of our superstars on our faculty. Someone who has been with us and is a graduate of University of South Carolina. For the detailed introduction, I will turn to Dean Kent.

Dr. Kent:

Thank you, Dr. Retchin. There was a question earlier about what are the current strengths of the College of Medicine at OSU. Clearly, one of our strengths is in the area of cardiovascular disease. I have to say there is one individual that in his five years at OSU has really grown into a national powerhouse in research in cardiovascular disease and that is Peter Mohler, who is our speaker today. He is the current director of the Dorothy M. Davis Heart and Lung Research Institute and is also the chair of the

Department of Physiology and Cell Biology. Peter has had an extraordinary career. He is clearly one of the nation's foremost researchers in cardiovascular disease with publications in *Nature Research* and *The Journal of Clinical Investigation*. These are the top journals for academic researchers in the country. He currently serves as a PI (principal investigator) and co-PI on six NIH awards, with millions of funding including a research training grant for training researchers in cardiovascular disease. He is a past recipient of the Pew Scholar, Catholic Scholar and these are extraordinary awards given to very few in the country. Three weeks ago we learned that Peter was the recipient of an Outstanding Investigator award. This is a new NIH award that was just created and it is given to seven individuals in the country and Peter is one of those individuals. The total funding is around \$6 million and it is to fund investigation in high risk, high reward translational research, which is clearly one of Peter's areas of expertise. It is very clear that he is an absolute star and it is a pleasure to have Peter with us today and we are looking forward to your talk. Thank you.

Dr. Mohler:

Thank you and behalf on all of the scientists, thank you for letting us out of our lockers for the day. I hope that everyone could look at the board up here if you do not mind. This is Ben. Ben is 37 years old. Ben just got married and is headed out on his honeymoon. This is the best day of Ben's life as he has told me many times. This is Ben seven days later. Ben suffered sudden cardiac arrest, was shocked six times to bring him back to life and spent the next 30 days in the Ross Heart Hospital in a hypothermic coma to preserve his brain function. During this time, Ben was implanted with a defibrillator and fortunately for Ben, over the next two years his defibrillator worked. It worked so much that it worked 200 times, which is unprecedented including 90 times in one day. Ben, unlike folks that have arrhythmias, is resistant to every known antiarrhythmic medication and surgical therapy at a lot of places in the north east and on the west coast did not happen to work for this gentleman. This is a man who cannot work, he cannot drive, and he cannot even take his kid up to bed at night because he is afraid he is going to fall down the stairs and drop his baby. What do you do in this situation?

A deep dive into his medical record revealed that his mom had syncope, or fainting, and sudden cardiac arrest and death in her early 50s. You see in a lot of cases these days that this is a genetic testing issue and in two days you can have your genetic testing done and you get it solved and everything goes back to normal. What we work on in our group are diseases that do not exist in the textbook. This is a perfect example of that where there was no genetic mutation found. This is the paradigm for our lab, how do you treat a disease that is not in the textbook. What we try to get with our trainees, fellows, students, and staff is really to question everything and leave no stone unturned. In this case, a very talented graduate student questioned the Human Genome Project with the idea that we know a lot less than what we think we know about the genes that exist in every single one of us. In fact, this graduate student found that in every single one of us, we have an extra gene that no one had ever seen before. The gentleman that I had talked to you about, not only had that gene, but also had a mutation in that gene. The questions that lined up for this graduate student is what is the role of this new gene in all of us that we all carry and how does a single typo or a change in one base pair of the 4.2 billion pieces of DNA (deoxyribonucleic acid) make such a drastic change that could really alter the lifestyle of this gentleman.

I am not going to go into the excruciating scientific details, but let's think about our hearts and the way that electricity moves around the heart just like a kitchen faucet. Things like sodium, potassium, and calcium move back and forth through these faucets on the surface of our hearts and just like our faucets at home, we can turn these on and turn them off. We can regulate them. They have washers so they do not drip. What we found with this new protein is that it acts like the washer at the top of your faucet to make sure it does not leak. In this gentleman, we found that this is really a washer that is leaking. The potassium was leaking out at the wrong place and the wrong time in the heart. What do we do about this?

This is where normal academic medicine usually stops. We write a paper, we write a grant, we graduate a graduate student, and everything looks good on the scorecard. The folks that have done academic medicine for a long time, Dr. Kent, Dr. Retchin, and Dr. Drake, always see this at the end of a grant submission or a paper that we "hope to use this information in this study to hope and promise that someday find a cure for this disease". It is our proposition that that is not good enough. What we are working at Ohio State is to make someday today.

What about the patient? The patient, despite the fact that this is published and there is a grant, is still sitting in a hospital bed in a coma, in fact septic at this point. What do we do? We work with people all around the campus to design new algorithms to figure out cures. These are people like Dean Williams and Dean Mann. This is really a team approach to predict arrhythmia therapy. When we put this in these fancy algorithms and talk to other scientists, they can come up with computational algorithms to predict disease therapy. Two are shown at the bottom; option A and option B. It does not matter what they are today, but the real problem with this is that there is no way to do option A or option B. In this case there was no FDA approved way to do this. We actually had to go back to the drawing board and work with our colleagues in the College of Pharmacy to design a new drug. There are a lot of people working a lot of time to design this very fancy ring structure that you see in front of you that had the ability to basically fix the washer in this gentleman. What you see on the left are his EKGs (electrocardiogram) before he had the drug and on the right are his EKGs after he had the drug. This is great to make a figure. Over the course of the last two years this gentleman has not had a single PVC (premature ventricular contractions), he has not had a single arrhythmia event, he has not gotten shocked, he is back at work, he is healthy, and his not taking up a bed in the Ross Heart Hospital. We really had an impact on one individual in the Columbus area.

That is one individual. What does this mean for the bigger population for the world we live in. When we start to look at this data and publish this data, we can then look at big data sets and see if anyone else in the world has this same problem. This is an example of three families. Each of these levels are another line of a generation. Men are boxes and women and circles. Every time you see a line through is a death. We found three families in the Netherlands that all have the same mutation. Generations upon generations upon generations of people have been dying of sudden cardiac death. In one foul swoop with these new medications, we can wipe out these diseases.

What about the broader scope of molecular mechanisms? This is something that the board probably talks about a lot. We know that between 1% and 5% of our patients that we see cost about 50% of our healthcare dollars. It is our proposition that if we can define these patients with genetic testing with early diagnosis that we can prevent a lot of these admissions and potentially readmissions 10, 20, 30, even 40, years before the event. This is illustrated on the left and in this chart here you can see we priced out the cost of this one gentleman's one event for his 30 day care. It is about \$1.2 million and this is for one of his 30 events over the last four years. Compare that to this new drug that cost about \$231 to make for a year for a prescription. That is one point and the second point is that we want to be able to design new diagnostics. We are working with new drug companies and with genetic testing companies to be able to take pennies on the dollar types of technology to be able to diagnose these events 10, 20, 30, 40 years and in this case in this event a young child that is sitting in the arms of the father with the disease. It is one thing to be able to treat thousands and hundreds or thousands of patients, but what if we could treat millions. One of the things we are doing now is taking this drug and repurposing it for patients that have much more common forms of arrhythmia like atrial fibrillation. 2.5 million people have atrial fibrillation and it is about a \$6 billion industry right now. The question is if this population can be scaled.

I will end with this quick example. This is a group of first Americans that we are working with in northern British Columbia. This is about a 15-hour drive north of Vancouver, Canada. It is difficult to get to, but it is absolutely beautiful. This is the Gitxan Tribe and

it has about 6,000 members. They were the last discovered Indian Tribe in the western hemisphere in North America. They are really an amazing group of people. To do genetics on these folks is really difficult because until about the turn of the century, they did not have last names so a lot of it is spoken word. About 10% to 15% of every child born to these families dies of sudden cardiac death to the point where they thought that their whole tribe was cursed. In the last decade, the Canadian Minister of Health made this one of the top five health priorities of the Canadian government. This landed on our desk about two years ago with the pedigree that you see at the bottom. That is really confusing so I translated it to the back of the minivan Columbus, Ohio stick figures that we see all the time. This is what one of these families looks like with 10 kids. What happens to a social structure in a tribe like this or even in a community like Columbus when what you see on the slide projector is about to happen, where you see one child disappear, then a second child disappear, then third child disappear, then a fourth disappear, and then a fifth child disappear in their sleep. It is no wonder these families thought they were cursed.

We got this on our corkboard and started looking, to find in a molecular autopsy, to see what is going on in these patients and take a new look at this disease. What we found was exactly the opposite of what the textbook told us we would find. We thought we would find scar tissue in these hearts, but in fact not finding scar we actually found fat. You can see on the left in that picture is what a normal heart looks like and on the right we thought we would see this big chunk of goo and that is what physicians have been treating them for. They have been treating them for scar with anti-inflammatories. What their hearts actually look like are a big wad of almost Swiss cheese and you can imagine when a piece of Swiss cheese tries to beat, it does not beat very well and it does not conduct electricity very well. We were able to find a new gene that caused this new form of disease, new diagnostic as I talked about before, and then importantly found a new therapy to be able to shrink these fat cells and make it so these kids get going with their lives. This is where we are and going back to this corkboard in this lab of the patient families that we are working with, I want to point out one in western Gambia where we have used the same approach and found that 1% of the patient population has a mutation that basically caused them to be susceptible for sudden cardiac death. That is a population of almost two million people. We are starting to think about treating hundreds and hundreds of thousands of patients at the same time.

One point I would like to make, when you talk to these people in Australia, Gambia, or UAE (United Arab Emirates), they have never heard of a Buckeye and none of them have ever heard about our kind of football, but every single one of them knows the impact of Ohio State in their everyday lives. Thank you for your time.

Dr. Kent:

Peter, that was absolutely outstanding and exemplary of the type of research that we can perform at OSU. Any questions for Peter?

Dr. Wadsworth:

Very interesting. Congratulations on your award. I know how difficult those are to win. That is fantastic. Terrific work, if I may say so. Two questions. In developing a new drug, my understanding is that it takes a long time for the FDA to approve a new drug. I was wondering if you could tell us the time scale and how you introduced that new drug. Secondly, on a long-term basis, when in the future will we be able to treat the DNA?

Dr. Mohler:

Two great questions. I want to give credit to the College of Pharmacy and I know Dean Mann is sitting behind me. One of the ways that we go about this is that you can go the normal route through the FDA, but in everything in life there are always ways around it. What we did is we took an existing drug and made some small tweaks to the existing

January 25, 2017 meeting, Wexner Medical Center Board

drug that was already FDA approved. Given the state of this specific patient, we were given some ability to use some compassionate use to be able to do it. This drug now is being used for patients with muscular dystrophy and stroke. It is something that we think is going to get big.

The second question is about when can we think about DNA and I would say that there is a lot of work including a lot of great work at Nationwide Children's Hospital where they are doing this with muscular dystrophy. This is an area called gene editing, which is one of the hottest parts of science now. Being able to go in and fix a typo and that is something that we are thinking about. It is CRISPR-Cas (clustered regularly interspaced short palindromic repeats). It won the Nobel Prize a couple years ago, I think. It is the kind of technology we hope to be able to go in and fix single base mutations.

Dr. Wadsworth:

In getting the approval, which was an accelerated version because of a preexisting drug. How long did it take to get that FDA approval for the modified drug?

Dr. Mohler:

This was in real time. The patient was sitting upstairs while we were doing this. From start to finish, we were about two years from finding the mutation to getting a drug approved.

Dr. Drake:

Looking at the two different cases and the onset of the disease in these genetically derived processes. The first one is interesting in that it looks like it comes on in the fourth or fifth decade, which gives you a chance to reproduce and have this not be a lethal gene to its own existence. The kids with the adipose replacement that must have been a different pattern where half of them were affected.

Dr. Mohler:

That is right. The inheritance was a little different. Normally, evolution would not let the first case happen and that is what we are trying to figure out why does this come on so late.

Dr. Drake:

In the case of the cursed tribe, 5,400 people with a lethal gene like....

Dr. Mohler:

Exercise, we know in the second case, makes the inflammation and fat deposition worse and we have known this in athletes for a long time for forms of ARVC. This is what we think is happening. Just to get back to this one point. Both of these patients, particularly the second group of patients while gene editing would be a wondering thing, most of these things would be treated with beta-blockers that are super cheap. If you know who has it, technology is great and we can do it for much cheaper. Thank you for your time.

(See Attachment XVI for background information, page 217)

Dr. Kent:

Thank you, Peter. You are absolutely outstanding.

January 25, 2017 meeting, Wexner Medical Center Board

Dr. Retchin:

I did want you to see the faculty that we are choosing for the WexMed talks and Peter that was really spectacular and shows that the medical center is on the move and we are very proud of everything you have done. We now need to go into executive session.

Ms. Link:

The board will now recess in to executive session to consider business sensitive trade secret matters required to be kept confidential by federal and state statues, discuss personnel matters regarding the employment and compensation of public officials, and to consult with legal counsel regarding pending or imminent litigation.

May I have motion?

Upon motion of Mrs. Wexner, seconded by Mr. Wexner, the Wexner Medical Center Board members adopted the foregoing motion by unanimous roll call vote, cast by board members Mr. Chatas, Dr. Retchin, Dr. Drake, Mr. Schottenstein, Mrs. Wexner, Ms. Krueger, Mr. Jurgensen, Mr. Shumate, and Mr. Wexner.

Attest:

Leslie H. Wexner
Chairman

Heather Link
Associate Secretary

January 25, 2017 meeting, Wexner Medical Center Board

(ATTACHMENT XII)

WEXNER MEDICAL CENTER: OPERATIONAL PERFORMANCE BENCHMARK
FY17 - Wexner - Top 1000 Results



Area	Category	Target	Actual	Delta	Color	Notes
Patient Care	30-Day Readmission Rate	10.0%	10.5%	+0.5%	Red	
	30-Day Mortality Rate	1.5%	1.5%	0.0%	Green	
Financial Performance	Operating Margin	15.0%	14.5%	-0.5%	Yellow	
	Net Patient Revenue	\$1.2B	\$1.15B	-\$50M	Red	
Operational Efficiency	Cost per Case	\$10,000	\$10,500	+\$500	Red	
	Days in Accounts Receivable	45	50	+5	Red	
Quality Improvement	Net Promoter Score	70	65	-5	Red	
	Customer Satisfaction	85	80	-5	Red	
Human Resources	Employee Turnover	10%	12%	+2%	Red	
	Employee Engagement	80%	75%	-5%	Red	
Community Impact	Charitable Contribution	\$5M	\$4.5M	-\$0.5M	Red	
	Community Health Improvement	90%	85%	-5%	Red	
Environmental Stewardship	Carbon Footprint	100,000 tons	110,000 tons	+10,000 tons	Red	
	Waste Recycling Rate	75%	70%	-5%	Red	

Legend:
 Green: On Target
 Yellow: Slightly Off Target
 Red: Significantly Off Target

Notes:
 1. Data is preliminary and subject to audit.
 2. Actual performance may vary due to seasonal fluctuations.
 3. Target values are based on industry benchmarks and organizational goals.
 4. Significant variances will be discussed in detail during the next board meeting.

OSU WEXNER MEDICAL CENTER
FY17 ENTERPRISE PERFORMANCE SCORECARD DEFINITIONS



Metric(s)	Definition
Engagement Score	Press Ganey determines the metric of workforce engagement based on employees' response to three metrics: 1. Willingness to refer OSUWMC to family, friends and colleagues for employment and healthcare 2. Pride in affiliation with OSUWMC 3. Overall satisfaction in working at OSUWMC
Diversity and Inclusion	Develop and implement a diversity plan to make the Medical Center a model of inclusive excellence.
Employee Turnover Rate	Turnover rate is the count of Faculty and Staff who actually exit the system, leave the Medical Center.
HCAHPS Score	Percent of inpatients who gave the hospital a rating of 8 or 10 on a scale from 0 (lowest) to 10 (highest).
CGCAHPS Score	Percent of outpatients who would definitely recommend this provider's office to family and friends.
Community Health Needs Assessment	Annual report on health needs of the community developed by the Central Ohio Hospital Council.
USMWR Operations Ranked	Metric score and target are displayed as the number of specialties ranked (in results for FY16 - published 7/31/16 - OSUWMC had 7 specialties ranked). The results for FY16 ranked 12 out of 18 specialties based on the combined score in four dimensions - Patient Safety (15%), Process (27%), Structure (36%) and Outcomes (22%). The other four specialties - Ophthalmology, Psychiatry, Rehabilitation and Rheumatology were based 100% on Reputation.
USMWR Best Med Schools	Metric score and target are displayed as the overall rank order compared to entire population of medical schools ranked. The results published 5/2/16 were based on combined score across eight metrics - Peer Assessment (20%), Residency Director Assessment (20%), NIH Research Grants (15%), NIH Research Grants per Faculty Member (15%), Median MCAT Total Score (10%), Median Undergraduate GPA (5%), Acceptance Rate (1%) and Faculty/Student Ratio (10%).
Readmissions	Estimates of unplanned readmission for any cause to an acute care hospital within 30 days of discharge from a hospitalization.
Mortality	This measure is expressed as the observed (actual) mortality in the inpatient hospital (deaths per 100 patients), compared to the "expected" mortality rate for similar patients at academic medical centers in the United States who participate in the University HealthSystem Consortium's Clinical Data Base.
PSI-90	It is a composite measure that includes PSI ED Prevalence (Lower Rate), PSI 90 Intracranial Pneumothorax Rate, PSI 90 Central Venous Catheter-Related Blood Stream Infection Rate, PSI 90 Postoperative Hip Fracture Rate, PSI 90 Postoperative Hemorrhage or Hematoma Rate, PSI 90
CAUTI	Standardized Infection Ratio) Measures all patients anywhere in the hospital that develop a catheter-related urinary tract infection.
Gain from Quality Based Reimbursement Programs	Financial gain (generally) from CMS based programs (i.e. Value Based Purchasing, Reimbursement Reduction Program and Hospital Acquired Conditions)
Payment Transformation Episodes	Number of pilot bundled payment episodes.
Total Value in Each Bundled Payment Episode	Total value is defined as quality over cost. Quality metrics are the roll-up of the CMS standard quality indicators for the given episode. Press-Ganey patient satisfaction metrics, and operational efficiency targets. Cost is the total cost based on the cost accounting system.
Inpatient Admissions	A count of patients admitted to the Health System during the reporting period. Inpatients are defined by the patient status assigned in IHS. Excludes normal newborns, Excludes Observations and Outpatients in a Bed.
# Hospital Transfers	Outside hospital/facility patient transfers for inpatients accepted as direct admissions or transfers to the Emergency Department (Main, OGIU).
New Patient Visits w/ a Physician	The number of unique new ambulatory patients seen in an OSUWMC outpatient location by a provider (physician, NP or PA). Will be tracked monthly and report fiscal YTD figures. A Unique new ambulatory patient is a patient that has had no OSUWMC activity (P or C) in last rolling three years with a triggering event of a billable encounter with a provider in one of our ambulatory locations. Will be calculated for all departments/clinics and include Afterhours and the ED but will show separately. A unique patient will only be counted once.
Total NIH Awards (incl. subawards)	The sum of all NIH Award funding segments (less sub-awards) received by the College of Medicine during the period in question.
Inpatient Length of Day	Inpatient days divided by inpatient discharges. Excludes normal newborns. Sourced from Health System Staff Reports.
Access - Days to 1st appointment for new patients with a physician - Primary Care	The average wait time for a new patient appointment with a Physician in a Family Medicine or General Medicine office as measured by when the appointment was requested to the scheduled date of service for the appointment.
Access - Days to 1st appointment for new patients with a physician - Specialty Care	The average wait time for a new patient appointment with a Physician in a Specialty Care office as measured by when the appointment was requested to the scheduled date of service for the appointment.
Median time patients spent in the emergency department, before they were admitted to the hospital as an inpatient	Median time in minutes from ED arrival to ED departure for patients admitted to the facility from the ED.
Total NIH Submissions	NIH Proposals submitted is the total of all proposals submitted by College of Medicine researchers over the period in question.
Integrated Net Margin	Combined financial reporting represents entire financial position of the OSU Wexner Medical Center including the OSU Health System, OSU Physicians Inc, and College of Medicine. Combined Medical Center Margin includes operating revenues, operating expenses, and Medical Center investments.
Operating Expenses per AA	Serves as an indicator that presents a metric that accounts for both inpatient and outpatient activities, and indicates how well expenses are in line with volumes.
Health Plan Per Member Per Year Costs	Per member per year costs (PMPY) are based on the sum of all medical/Rx costs including 90 day run out and 180 day (incurred but not reported) factors, divided by the number of members with medical coverage. It is the sum of the PMPY for medical claims and the PMPY for pharmacy claims. PMPY will be calculated on a calendar year to align with the benefit year and allow for the reporting lag due to 90 day claim run out.
Net Revenue Improvement (Five Cycle)	Additional net revenue (not related to volume) through improvement in revenue cycle processes.
Philanthropy \$	This metric represents new fundraising activity comprised of Donations (Unrestricted), Endowment (OSP) including outright gifts and pledges, planned gifts (irrevocable and revocable) and private grants (industry, foundations and other organizations).

(ATTACHMENT XIII)



Wexner Medical Center Board Public Session Health System Financial Summary

January 25, 2017



The Ohio State University Health System Financial Highlights

For the YTD Ended: December 31, 2016

Admissions	
Budget	1.1%
Prior Yr	2.9%
Actual	30,632
Budget	30,290
Prior Yr	29,755

Surgeries	
Budget	1.7%
Prior Yr	3.5%
Actual	21,689
Budget	21,328
Prior Yr	20,961

O/P Visits	
Budget	-3.8%
Prior Yr	1.2%
Actual	866,260
Budget	900,405
Prior Yr	855,961

Worked Hrs / Adjusted Admit	
Budget	0.5%
Prior Yr	0.8%
Actual	198
Budget	200
Prior Yr	200



The Ohio State University Health System

Financial Highlights

For the YTD Ended: December 31, 2016

Operating Revenue	
Budget	0.6%
Prior Yr	6.1%
Actual	\$1,343,070
Budget	\$1,335,202
Prior Yr	\$1,265,340

Controllable Costs	
Budget	-0.3%
Prior Yr	-9.2%
Actual	\$1,048,146
Budget	\$1,044,977
Prior Yr	\$959,906

Excess Revenue over Expense	
Budget	3.8%
Prior Yr	-13.0%
Actual	\$84,620
Budget	\$81,504
Prior Yr	\$97,314

Days Cash on Hand	
Jun FY16	0.0%
PY MTD	15.1%
Actual	114.3 \$711M
Jun FY16	114.3 \$674M
PY MTD	99.3 \$559M

The Ohio State University Health System

Consolidated Statement of Operations

For the MTD ended: October 31, 2016
(in thousands)

OSUHS						
	Actual	Budget	Act-Bud Variance	Budget % Var	Prior Year	PY % Var
OPERATING STATEMENT						
Total Operating Revenue	\$ 226,027	\$ 226,661	\$ (1,634)	-0.7%	\$ 226,357	-0.6%
Operating Expenses						
Salaries and Benefits	99,373	99,733	360	0.4%	95,006	-4.6%
Supplies	24,146	23,781	(365)	-1.5%	22,129	-8.1%
Drugs and Pharmaceuticals	21,605	23,638	2,033	8.6%	28,064	23.0%
Services	24,156	24,429	273	1.1%	24,000	-0.7%
Depreciation	11,701	11,395	(306)	-2.7%	11,578	-1.1%
Interest	3,328	3,307	(21)	-0.6%	3,480	4.4%
Other	12,457	12,494	37	0.3%	9,299	-34.0%
Total Expense	196,766	198,777	2,011	1.0%	193,554	-1.7%
Gain (Loss) from Operations (pre MCI)	29,261	27,884	377	1.4%	32,803	-13.8%
Medical Center Investments	(12,486)	(12,426)	(60)	0.5%	(11,407)	-8.5%
Income from Investments	683	232	451	194.4%	168	306.5%
Other Gains (Losses)	(29)	-	(29)	-	33	-
Excess of Revenue over Expense	\$ 16,428	\$ 16,690	\$ 739	4.7%	\$ 21,997	-23.9%

The Ohio State University Health System Consolidated Statement of Operations

For the MTD ended: November 30, 2016
(in thousands)

OSUHS						
	Actual	Budget	Act-Bud Variance	Budget % Var	Prior Year	PY % Var
OPERATING STATEMENT						
Total Operating Revenue	\$ 219,382	\$ 213,097	\$ 6,285	2.9%	\$ 201,180	9.0%
Operating Expenses						
Salaries and Benefits	105,000	99,859	(5,101)	-5.1%	98,494	-4.6%
Supplies	22,777	22,618	(159)	-0.7%	20,711	-10.0%
Drugs and Pharmaceuticals	22,372	22,533	161	0.7%	18,978	-17.9%
Services	22,367	23,300	933	4.0%	20,086	-11.4%
Depreciation	11,522	10,907	(615)	-5.6%	11,462	-0.5%
Interest	3,343	3,296	(47)	-1.4%	3,473	3.7%
Other	12,891	12,452	(439)	-3.4%	9,300	-38.9%
Total Expense	200,262	195,005	(5,257)	-2.7%	182,492	-9.7%
Gain (Loss) from Operations (pre MCI)	19,120	18,092	1,028	5.7%	18,688	2.3%
Medical Center Investments	(12,278)	(12,407)	129	-1.0%	(31,816)	61.4%
Income from Investments	784	237	527	222.4%	256	198.4%
Other Gains (Losses)	(138)	-	(138)	-	-	-
Excess of Revenue over Expense	\$ 7,468	\$ 5,922	\$ 1,546	26.1%	\$ (12,072)	-158.0%

 THE OHIO STATE UNIVERSITY
WEXNER MEDICAL CENTER

The Ohio State University Health System Consolidated Statement of Operations

For the YTD Ended: December 31, 2016
(in thousands)

OSUHS						
	Actual	Budget	Act-Bud Variance	Budget % Var	Prior Year	PY % Var
OPERATING STATEMENT						
Total Operating Revenue	\$ 1,345,070	\$ 1,355,205	\$ 7,895	0.6%	\$ 1,265,340	6.1%
Operating Expenses						
Salaries and Benefits	600,678	595,386	(5,292)	-0.9%	568,175	-5.7%
Supplies	144,987	140,519	(4,468)	-3.2%	134,809	-7.5%
Drugs and Pharmaceuticals	134,513	138,961	4,448	3.2%	115,161	-16.8%
Services	140,738	143,595	2,857	2.0%	134,332	-4.8%
Depreciation	70,318	67,312	(3,006)	-4.5%	69,436	-1.3%
Interest	20,035	19,896	(139)	-0.7%	20,833	4.3%
Other Operating Expense	72,568	73,525	957	1.3%	55,158	-31.6%
Medical Center Investments	74,813	74,505	(308)	-0.4%	70,022	-6.6%
Total Expense	1,258,450	1,253,899	(4,751)	-0.4%	1,168,026	-7.7%
Excess of Revenue over Expense	\$ 84,620	\$ 81,504	\$ 3,116	3.8%	\$ 97,314	-13.0%
Financial Metrics						
Adjusted Admissions	57,962	56,700	1,262	2.2%	54,600	6.2%
Operating Revenue per AA	\$ 23,171	\$ 23,549	\$ (378)	-1.6%	\$ 23,175	0.0%
Total Expense per AA	\$ 20,475	\$ 20,822	\$ 347	1.7%	\$ 20,157	-4.6%
Operating EBDA Margin	18.4%	18.1%	0.3%	1.4%	20.2%	-8.9%
Days Cash on Hand	114.3				99.3	15.1%
Debt Service Coverage	3.7	3.6	0.1	2.3%	3.0	-0.9%

 THE OHIO STATE UNIVERSITY
WEXNER MEDICAL CENTER

The Ohio State University Wexner Medical Center Combined Statement of Operations

For the YTD Ended: December 31, 2016
(in thousands)

	Actual	Budget	Act-Bud Variance	Budget % Var	Prior Year	PY % Var
OPERATING STATEMENT						
Total Operating Revenue	\$ 1,654,395	\$ 1,630,700	\$ 23,695	1.5%	\$ 1,572,242	5.2%
Operating Expenses						
Salaries and Benefits	873,124	878,775	5,651	0.6%	828,091	-5.4%
Supplies	156,985	150,873	(6,112)	-4.1%	147,051	-8.7%
Drugs and Pharmaceuticals	139,602	144,132	4,530	3.1%	127,906	-9.1%
Services	181,165	183,460	2,295	1.3%	172,237	-5.2%
Depreciation	76,844	73,528	(2,318)	-3.1%	76,053	0.3%
Interest/Debt	25,770	25,580	(190)	-0.7%	26,699	3.5%
Other Operating Expense	87,127	88,474	1,347	1.5%	66,564	-30.9%
Medical Center Investments	7,836	4,773	(3,063)	-64%	11,036	29.0%
Total Expense	1,547,453	1,549,595	2,142	0.1%	1,455,647	-6.3%
Excess of Revenue over Expense	\$ 106,939	\$ 81,102	\$ 25,837	31.9%	\$ 116,596	-8.3%
Financial Metrics						
Adjusted Admissions	57,962	56,700	1,262	2.2%	54,600	6.2%
OSUP Physician Encounters	1,297,111	1,312,712	(15,601)	-1.2%	1,170,800	10.8%
Operating Revenue per AA	\$ 23,171	\$ 23,549	\$ (378)	-1.6%	\$ 23,175	0.0%
Total Expense per AA	\$ 20,475	\$ 20,822	\$ 347	1.7%	\$ 20,157	-1.6%
This statement does not conform to Generally Accepted Accounting Principles. Different accounting methods are used in each of these entities and on eliminating entries are included.						



The Ohio State University Wexner Medical Center Combined Statement of Operations

For the YTD Ended: December 31, 2016
(in thousands)

	ACTUAL	BUDGET	ACT-BUD VARIANCE	BUDGET % VAR	PROR YEAR	PY % Var
Health System						
Revenues	\$ 1,343,070	\$ 1,335,205	\$ 7,865	0.6%	\$ 1,265,340	6.1%
Expenses	1,258,450	1,253,699	(4,751)	-0.4%	1,198,025	-7.7%
Net	84,620	81,504	3,116	3.8%	97,314	-13.0%
OSUP						
Revenues	\$ 201,241	\$ 199,831	\$ 1,410	0.7%	\$ 199,342	1.0%
Expenses	189,878	193,257	3,379	1.7%	188,110	-0.9%
Net	11,362	6,573	4,789	72.9%	11,232	1.2%
COMMOHS						
Revenues	\$ 110,084	\$ 95,954	\$ 14,420	15.1%	\$ 107,500	2.3%
Expenses	99,125	102,630	3,514	3.4%	99,811	0.4%
Net	10,957	(6,676)	17,632	267.1%	8,689	36.1%
Total Medical Center						
Revenues	\$ 1,654,395	\$ 1,630,700	\$ 23,695	1.5%	\$ 1,572,242	5.2%
Expenses	1,547,453	1,549,595	2,142	0.1%	1,455,647	-6.3%
Net	106,939	81,102	25,837	31.9%	116,596	-8.3%
This statement does not conform to Generally Accepted Accounting Principles. Different accounting methods are used in each of these entities and no eliminating entries are included.						

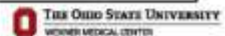

Ohio State University Physicians, Inc.

Consolidated Statement of Operations

For the YTD Ended: December 31, 2016
(in thousands)

OSUP						
	Actual	Budget	Act-Bud Variance	Budget % Var	Prior Year	PY % Var
OPERATING STATEMENT						
<u>Revenues</u>						
Total Revenue	\$ 201,241	\$ 199,831	\$ 1,410	0.7%	\$ 199,342	1.0%
<u>Expenses</u>						
Faculty Salaries and Benefits	\$ 140,607	\$ 143,370	\$ 2,763	1.9%	\$ 130,037	-8.1%
Non Faculty Salaries and Benefits	43,624	46,710	3,086	6.6%	41,891	-4.1%
Supplies	3,659	3,890	231	5.9%	3,635	-0.7%
Drugs and Pharmaceuticals	5,088	5,171	82	1.6%	12,745	60.1%
Purchased Services	19,215	16,415	(2,800)	-17.1%	16,806	-14.3%
Depreciation	2,170	2,117	(53)	-2.5%	2,147	-1.1%
Interest	205	186	(19)	-10.2%	231	11.3%
Other Operating Expense	14,559	14,949	390	2.6%	11,406	-27.6%
Medical Center Investments	(39,251)	(39,552)	(301)	0.8%	(30,787)	-27.5%
Total Expenses	189,878	193,257	3,379	1.7%	188,110	-0.9%
Gain(Loss)	\$ 11,362	\$ 6,573	\$ 4,789	72.9%	\$ 11,232	1.2%

10



The Ohio State University College of Medicine

Statement of Operations

For the YTD Ended: December 31, 2016
(in thousands)

COM						
	Actual	Budget	Act-Bud Variance	Budget % Var	Prior Year	PY % Var
OPERATING STATEMENT						
<u>Sources</u>						
General Funds and Appropriations	\$ 46,919	\$ 43,776	\$ 3,143	7.2%	\$ 46,315	1.3%
Support from related entities	22,037	14,434	7,603	52.7%	23,240	-5.2%
Other	41,127	37,454	3,673	9.8%	38,006	8.2%
Total Sources	\$ 110,083	\$ 95,664	\$ 14,419	15.1%	\$ 107,561	2.3%
<u>Uses</u>						
Faculty Salaries	\$ 35,397	\$ 37,836	\$ 2,539	6.7%	\$ 33,966	-4.2%
Non Faculty Salaries	31,263	31,410	147	0.5%	31,666	1.3%
Benefits	21,554	23,962	2,408	10.8%	22,557	3.6%
Supplies	8,339	6,464	(1,875)	-29.0%	8,617	3.2%
Services	21,212	23,450	2,238	9.5%	21,099	-0.5%
Debt	5,530	5,498	(32)	-0.6%	5,535	0.1%
Capital	3,356	4,099	743	18.1%	4,479	24.9%
Medical Center Investments	(27,326)	(20,199)	(7,127)	-35.3%	(20,199)	-2.4%
Total Uses	99,125	102,639	3,514	3.4%	99,511	0.4%
Gain(Loss)	\$ 10,957	\$ (6,975)	\$ 17,932	—	\$ 8,050	98.1%

11

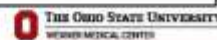

The Ohio State University Wexner Medical Center

Combined Balance Sheet

As of December 31, 2016
(In thousands)

	December 2016	June 2016	Change
Cash	\$ 595,029	\$ 663,692	\$ (68,663)
Net Patient Receivables	386,903	362,813	24,090
Other Current Assets	374,690	321,795	52,895
Assets Limited as to Use	385,697	255,498	130,199
Property, Plant & Equipment - Net	1,511,662	1,490,521	21,341
Other Assets	415,203	432,303	(17,100)
Total Assets	\$ 3,669,383	\$ 3,546,622	\$ 122,761
Current Liabilities	\$ 346,473	\$ 314,143	\$ 34,330
Other Liabilities	113,097	99,335	13,762
Long-Term Debt	879,669	904,418	(24,749)
Net Assets - Unrestricted	1,815,125	1,711,408	103,717
Net Assets - Restricted	513,019	517,318	(4,299)
Liabilities and Net Assets	\$ 3,669,383	\$ 3,546,622	\$ 122,761

This Balance sheet is not intended to conform to Generally Accepted Accounting Principles. Different accounting methods are used in each of these entities and no eliminating entries are included.



(ATTACHMENT XIV)

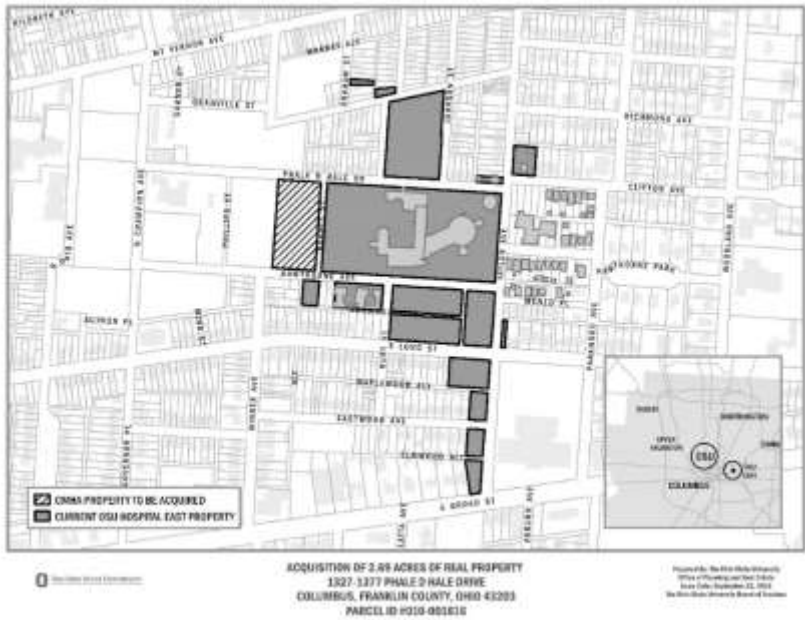

OSU East 2.69 Acre Parcel Acquisition

- Project Review. The Chairman, at the November Medical Center Board meeting, asked the Facility Group to review the advisability of the acquisition by the University of a 2.69 acre parcel on behalf of OSU East at a purchase price of \$550,000.

Partners Achieving Community Transformation [PACT] will provide a \$185,000 grant to CMHA from the Job Creation Tax Incentive Fund, established by the City of Columbus and the University during the expansion of the OSU WMC. This grant will assist CMHA in acquisition and development of housing adjacent to CMHA's existing property within the PACT geography.

- Recommendation. Upon review, we recommend the approval of the purchase for two reasons:
 - Strategic Expansion
 - Net Expenditure

Strategic Expansion Potential

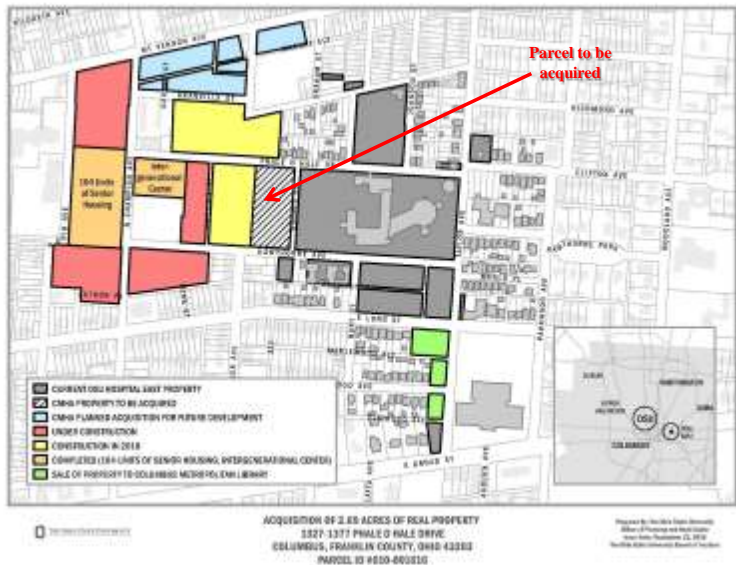

Net Expenditure for Parcel

- November 2015, the University Board of Trustees, approved the sale of 3 non-strategic properties for the price of \$187,000 – which transaction was subsequently authorized by the Ohio Legislature.
- Looking at the “buy” and “sale” transactions together, the University (i) has disposed of non-strategic parcels and has acquired a parcel having strategic value and (ii) has furthered the overall development of the area surrounding OSU East with a planned residential development.
- Given strategic value and net cost of the parcel, we are of the opinion that the previously negotiated purchase should proceed as requested.

OSU East 2.69 Acre Parcel Acquisition

- Project Review. The Chairman, at the November Medical Center Board meeting, asked the Facility Group to review the advisability of the acquisition by the University of a 2.69 acre parcel on behalf of OSU East at a purchase price of \$735,000
- Recommendation. Upon review, we recommend the approval of the purchase for two reasons:
 - Strategic Expansion
 - Net Expenditure

Strategic Expansion Potential

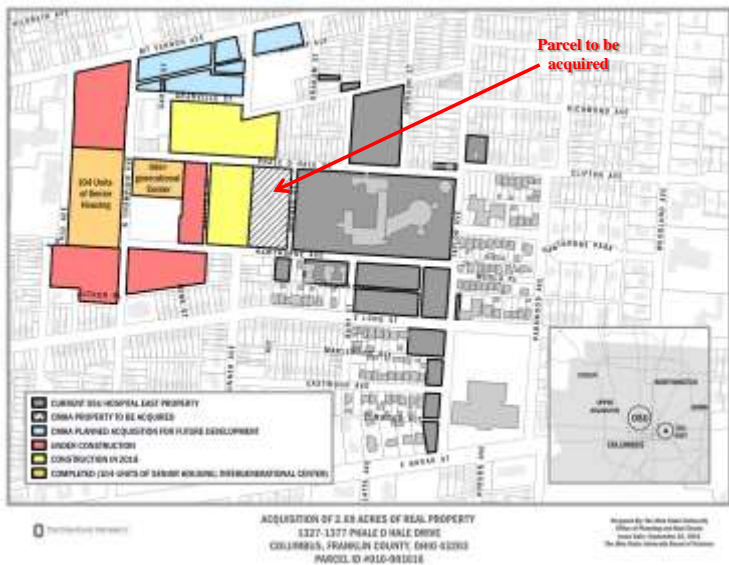

Net Expenditure for Parcel

- May 2016, the University Board of Trustees, approved the sale of 3 non-strategic parcels of land for the price of \$187,000 – which transaction was subsequently approved by the Ohio Controlling Board.
- Looking at the “buy” and “sale” transactions together, the net price for the acquired 2.69 acre parcel is \$548,000.
- Given strategic value and net cost of the parcel, we are of the opinion that the previously negotiated purchase should proceed as requested.

Strategic Expansion Potential

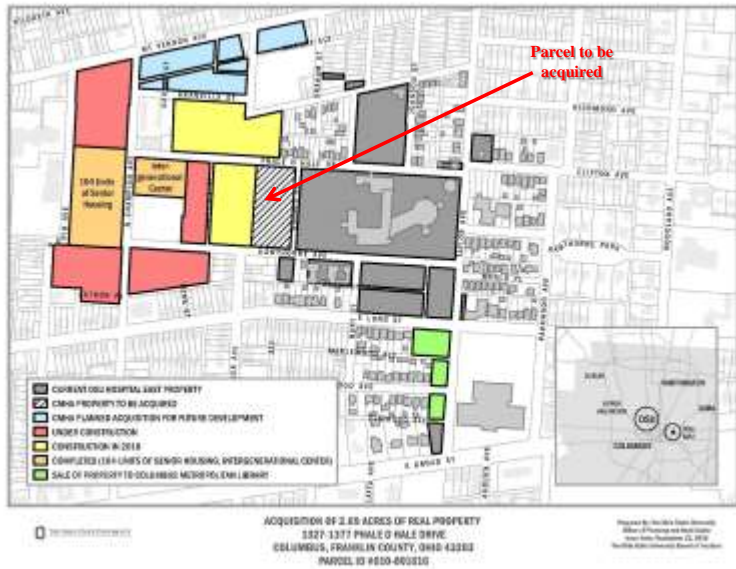

Project Data Sheet for Board of Trustees Approval

Transportation Plan Implementation

OSU-170391 (CNI# 16000036)

Project Location:

• approval requested and amount	
prof services/construction	\$16.5M
• project budget	
professional services	\$3.3M
construction w/contingency	\$13.2M
total project budget	\$16.5M



- project funding
 - university debt
 - development funds
 - university funds
 - auxiliary funds
 - state funds

• project schedule	
BoT approval	01/17
design/bidding	02/17 - 08/17
construction	phased

- project delivery method
 - general contracting
 - design/build
 - construction manager at risk

- planning framework
 - this project is included in the FY 2017 Capital Investment Plan

- project scope
 - construct and improve parking facilities as an enabler for Cannon Drive Relocation - Phase 1
 - improvements include expanding surface parking lots; bus shelters and bus access road improvements; intersection and signal improvements; constructing a transit hub on Hemick Drive.

- approval requested
 - approval is requested to enter into professional services and construction contracts

• project team	
University project manager:	Tom Elgert
Criteria AE:	
Design-Builder:	

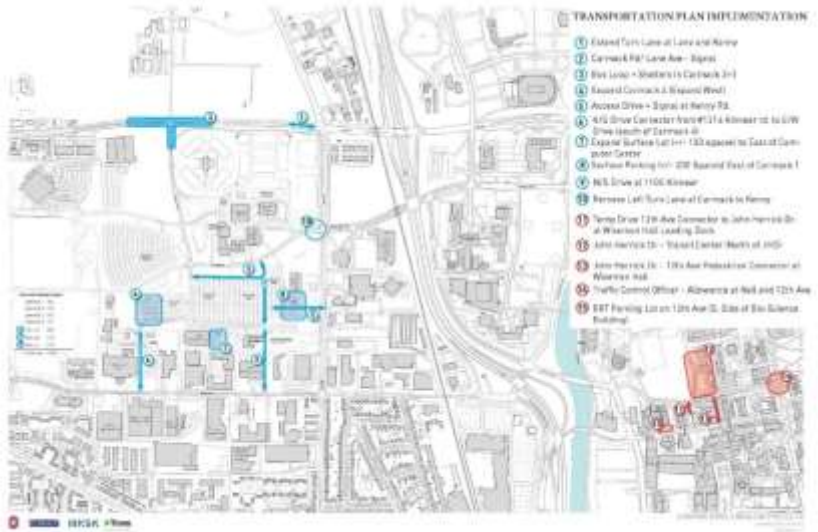

Mending Broken Hearts: "Someday" is today.

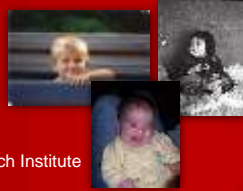

Peter J. Mohler, PhD

Director – Dorothy M. Davis Heart & Lung Research Institute

Chair, Department of Physiology & Cell Biology

Professor, Depts of Internal Medicine and Physiology & Cell Biology

William D. and Jacquelyn L. Wells Chair in Cardiovascular Research

Associate Dean, Basic Research; College of Medicine

The Ohio State University Wexner Medical Center



Patient consented to presentation of story

WEX<TALKS>





WEX<TALKS>

THE OHIO STATE UNIVERSITY
WEXNER MEDICAL CENTER

In two years, defibrillator discharged >200 times
(90 in one day).

Resistant to all anti-arrhythmic medications.

Surgical therapy @ multiple Institutions did not resolve disease.

Can't work, can't drive...
Mother displayed fainting (syncope), died suddenly in 50's.

Genetic testing?

Negative for known arrhythmia gene mutations.

WEX<TALKS>

THE OHIO STATE UNIVERSITY
WEXNER MEDICAL CENTER

How do you treat a disease that is not in the textbook?

Question everything.

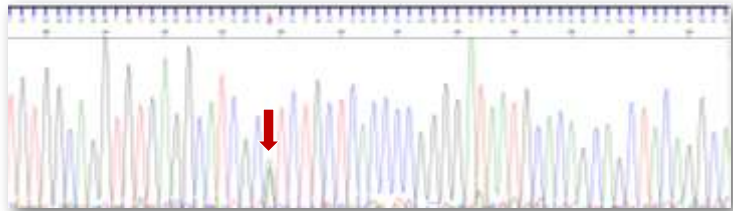

Discovery of new human gene/protein.
Discovery of mutation in new protein.

What is role of new gene?
How does gene mutation cause arrhythmia?





“hope and promise of someday finding a cure”

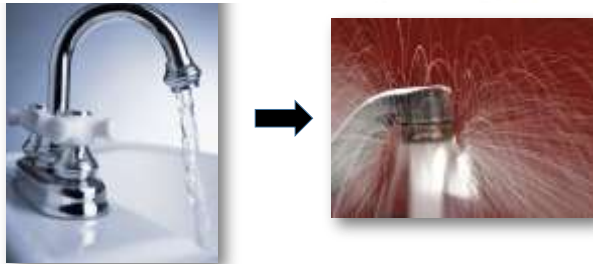



What about the patient?

WEX<TALKS>

The Ohio State University
WEXNER MEDICAL CENTER

Novel 'team' approaches to predict disease therapy

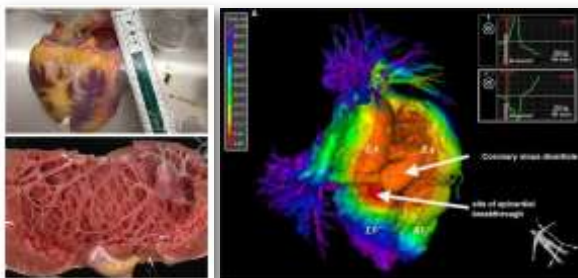

Option A: Increase atrial pacing **AND**

Option B: Block exactly 40% of specific potassium current

Problem: No FDA approved therapies for either Option A or B.

WEX<TALKS>

The Ohio State University
WEXNER MEDICAL CENTER

Creating new options: Designing old drugs for a new disease

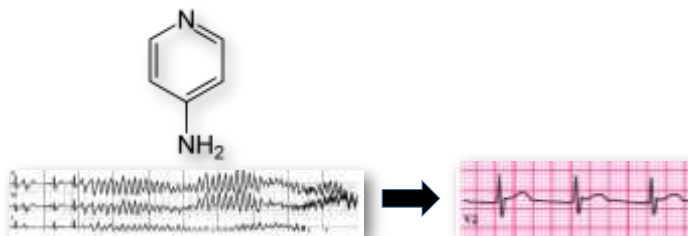

WEX<TALKS>

The Ohio State University
WEXNER MEDICAL CENTER

Impact beyond Columbus, Ohio

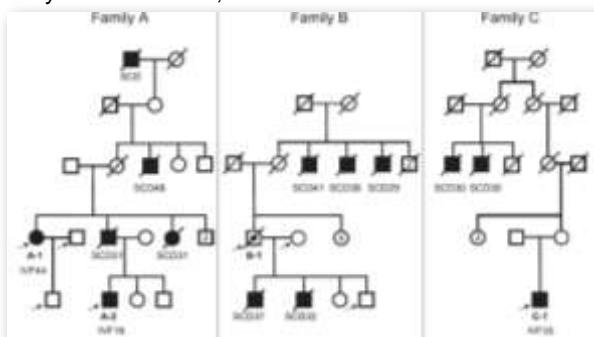

Broader scope of Molecular Medicine?

WEX<TALKS>

The Ohio State University
WEXNER MEDICAL CENTER

“Hot spotting” high-risk patients



WEX<TALKS>

The Ohio State University
WEXNER MEDICAL CENTER

Impact of Molecular Medicine 1 person: 1 event

\$231 for new drug (\$5 co-pay)

\$1,200,000 for just initial event (\$50 co-pay)... now up to 30+ events in four years

Prevention of future family events?

Working with company to develop compound for arrhythmia therapy in general population. Can this process be scaled?

WEX<TALKS>

The Ohio State University
WEXNER MEDICAL CENTER



5400 member "First Nation" Gitksan Tribe

Last Discovered Tribe in 1860s

Primarily oral histories.

No last names until 1880s

Generations with sudden death in childhood.

Last decade Canadian Minister of Health put issue as one of top 5 health priorities.

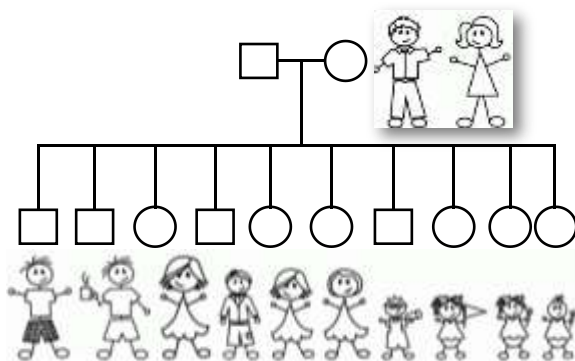
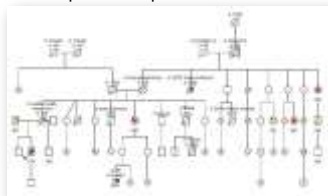

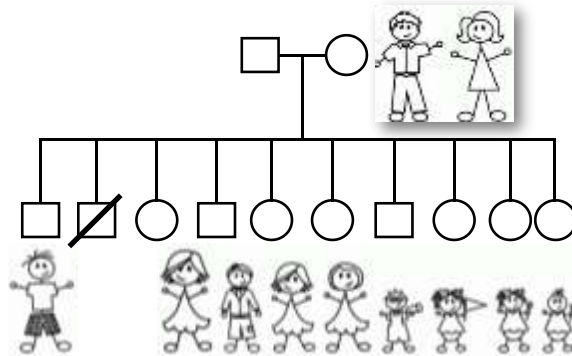

WEX<TALKS>

The Ohio State University
WEXNER MEDICAL CENTER

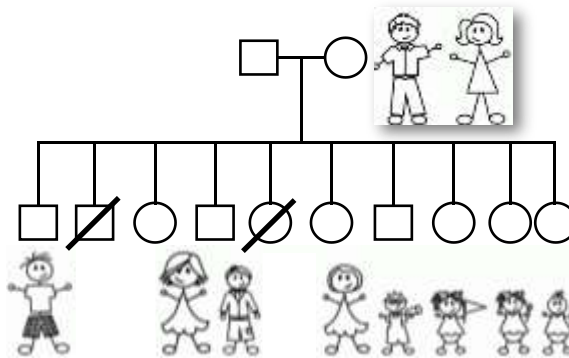

WEX<TALKS>

The Ohio State University
WEXNER MEDICAL CENTER

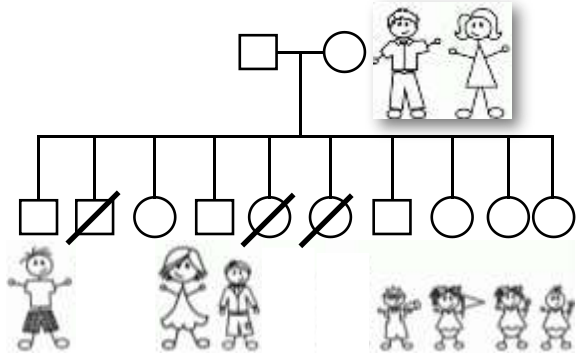

WEX<TALKS>

The Ohio State University
WEXNER MEDICAL CENTER

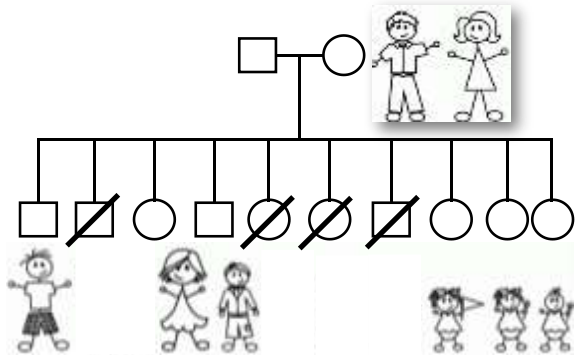

WEX<TALKS>

The Ohio State University
WEXNER MEDICAL CENTER

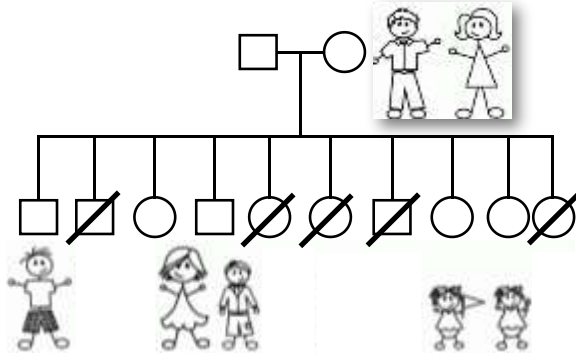

2 years: New cause of disease, new genetic mutation, new disease diagnostic, & new therapy to treat population.



