

THE OHIO STATE UNIVERSITY
OFFICIAL PROCEEDINGS OF THE
ONE THOUSAND THREE HUNDRED AND SEVENTY-NINTH MEETING
OF THE BOARD OF TRUSTEES

Columbus, Ohio, February 1, 2002

The Board of Trustees met at its regular monthly meeting on Friday, February 1, 2002, at The Ohio State University Fisher College of Business, Columbus, Ohio, pursuant to adjournment.

**

**

**

Minutes of the last meeting were approved.

**

**

**

February 1, 2002 meeting, Board of Trustees

The Chairman, Mr. Brennan, called the meeting of the Board of Trustees to order on February 1, 2002, at 10:40 a.m. He requested the Secretary to call the roll.

Present: David L. Brennan, Chairman, James F. Patterson, Zuheir Sofia, Tami Longaberger, Daniel M. Slane, Dimon R. McFerson, Jo Ann Davidson, Kevin R. Filiatraut, and Joseph A. Shultz.

--0--

STUDENT RECOGNITION AWARD

Mr. Shultz:

This morning the Board of Trustees is proud to recognize someone who really excels in academic excellence through our Student Recognition program. Nominated by the Fisher College of Business, we're proud to recognize Weston Tucker.

An undergraduate majoring in finance, Weston exemplifies what it means to be a student at The Ohio State University through his academic achievement and service to the University and in his college. Weston spent this summer as a Student Fellow for the AT&T Educational Alliance. During this experience, he performed in-depth research and developed recommendations on AT&T e-business and the e-business market.

As a student research assistant in the Fisher College of Business, Weston worked on a project in corporate strategy, attempting to define the major factors of a firm's competitiveness, and therefore predict how certain companies can best position themselves in a highly competitive industry. Weston has also added an international component to his education here at Ohio State by spending a summer in Ecuador, participating in an intensive Spanish program.

In addition to Weston's extensive academic experiences, he is also a leader in and around campus. He has helped to create the Mid-East Scholar's Program and currently serves on their executive committee. As an Honors' Ambassador, he is helping to recruit other high potential high school students to our University. Amid all of these activities, Weston also finds time to volunteer, working with students at the Indianola Middle School.

Weston, on behalf of President Kirwan and the Board of Trustees, I wish to congratulate you on all of your accomplishments, and wish you the best of luck achieving your goals, as I present to you the Student Recognition Award.

Mr. Weston M. Tucker:

Thank you.

--0--

Mr. Brennan:

Before calling on President Kirwan for his report, I just want to make a personal comment and say how glad I am to be back at the Board of Trustees meeting. I've had a little vacation – not one I'd recommend you take. I want to thank all of those in the audience who cared enough to pray and worry about me, and send me notes. Thank you.

February 1, 2002 meeting, Board of Trustees

President William E. Kirwan:

Mr. Chairman, I know I speak for everyone in the room that we are delighted to have you back with us today.

Mr. Brennan:

Thank you.

--0--

PRESIDENT'S REPORT

President William E. Kirwan:

Members of the Board of Trustees, it has been almost two months since we met and, as usual, quite a lot has happened on campus. I will report to you on some of this activity, but given that these remarks will be followed by a major presentation, I will keep them relatively brief.

First, as you may have read or heard, last month Provost Ed Ray agreed to extend tenure in the College of Medicine and Public Health – that is extend the tenure probationary period to 11 years for clinical faculty. This was a major decision, and I was deeply impressed with the care and consideration Ed gave to the proposal and the extent of his consultations across the University. Further, I am in complete agreement with his decision and admire the forthright manner in which he addressed the topic at last month's Senate meeting.

Some people have suggested that this decision should have been subject to a vote of the entire University Senate. However, that suggestion ignores the existence of a Senate rule, duly adopted in 1996, that clearly calls for the provost to make such decisions. The College of Medicine and Public Health faculty acted in good faith over an entire year in developing this proposal. In my view, to have suddenly imposed upon the College of Medicine and Public Health faculty, in an ad hoc fashion, an additional requirement not stipulated in the Senate's rules would have been a flagrant abuse of the principals of shared governance.

As Ed made clear in his Senate address, we would welcome a constructive dialogue on ways to improve the process, so long as the resulting rule maintains flexibility in tenure and promotion procedures and guidelines among the academic units.

Ed also addressed two other important matters in his annual Senate address, both of which I also strongly support. One is the appointment of an ad hoc committee to study the Colleges of the Arts and Sciences and report back by the end of the Autumn Quarter. The five separate colleges within the Arts and Sciences – Arts, Biological Sciences, Humanities, Mathematical and Physical Sciences, and Social and Behavioral Sciences – represent the core of our undergraduate curriculum.

The concern is that we are not taking maximum advantage of the synergies that can exist among these programs. A thorough examination of how we can do so seems very worthwhile. The committee will be chaired by former president Ed Jennings, and will include some of the most distinguished faculty in the Arts and Sciences colleges.

The other item concerns requests from the Moritz College of Law and the Fisher College of Business to establish clinical faculty positions. Clinical faculty are highly qualified, non-tenured individuals who share and draw from their significant real-world experience to teach but who do little research.

PRESIDENT'S REPORT (contd)

President Kirwan: (contd)

Offering such positions is critical for these colleges, and perhaps others, if they are to compete successfully with top national programs. I join Ed in urging the Senate leadership to help craft acceptable enabling legislation, then to consider individual college proposals on their merits.

While all of this has been going on, we have continued to receive a large amount of good news. Let me share some of it with you.

First, we continue to attract world-class talent to Ohio State. A recent example is the appointment of Monika Aring, as director of the Center on Education and Training for Employment.

Founded in 1965, the Center is a leading resource in developing employment-related education and training. Since 1993, it has attracted almost \$55 million in contract grants and services. While the Center is already global in reach, we expect our new director to lead it to even greater heights as it addresses the challenges of our knowledge economy. This will include the development of comprehensive workforce and training systems in developing nations, as well as increased collaboration on and off campus between education and business.

Ms. Aring is the ideal person to lead this Center at this time. A magna cum laude graduate of Brooklyn College, with two undergraduate degrees, she is also a graduate of Harvard's John F. Kennedy School of Government, where she received a Master's in Public Administration. She comes to us from the Center for Workforce Development at the Education Development Center in Washington, DC. She has worked in over 28 countries on every continent, in identifying best practices in private sector led workforce development systems.

Monika is with us this morning, and I would like to ask her to stand so that we may welcome her to our community.

We received another piece of good news just this past week when Dr. Chris Hammel of the Los Alamos National Laboratory accepted an offer to become the Ohio Eminent Scholar in Experimental Physics. Dr. Hammel is a fellow at Los Alamos and of the American Physical Society. His research has strong interdisciplinary components and focuses on such topics as using the way electrons spin to transfer information, using the special properties of quantum systems to create far more powerful computers for such purposes as code breaking, and using magnetic resonance microscopy to provide detailed images of cell interiors and of impurities buried beneath semiconductor and metal surfaces.

As you know, the Department of Physics is already very well regarded. It was ranked 14th among public universities in the last National Research Council rankings, tied for 14th in the *U.S. News and World Report* rankings, and ranked first in our initial Selective Investment Award competition in 1998. Dr. Hammel, who will join us later this year, is the second Ohio Eminent Scholar in Physics – the first was John Wilkins, who joined us in 1988.

I'm also pleased to report that members of our faculty continue to win prestigious honors and awards. For example, Jacqueline Jones Royster, professor and associate dean of the College of Humanities, has won the Modern Language Association's Mina P. Shaughnessy Award. This is one of 16 major awards given out annually by the Modern Language Association, so it is truly an honor. She received this award for her book, "Traces of a Stream: Literacy and Social Change Among African American Women."

PRESIDENT'S REPORT (contd)

President Kirwan: (contd)

In addition, the American Physical Society has recognized four members of our faculty for their contributions to physics research. The four are: Richard Furnstahl, Ulrich Heinz, Ciriyaam Javaprakash, and Robert Scherrer.

We are also proud that the Department of East Asian Languages and Literatures and the Institute of Chinese Studies have received a \$2 million grant from the Freeman Foundation. The grant will support Chinese language and culture distance learning courses in the College of Humanities and a variety of undergraduate Asian study course enhancements.

Next, Ohio State won two of the three Ohio Board of Regents grant proposals submitted last fall. One grant -- and this, I know, is of special interest to the Board of Trustees -- supports a collaborative project between the Fisher College and the regional campuses to create a new business major on the regional campuses. The other grant will support an Information and Scientific Literacy proposal to identify, exemplify, and deliver, via the Web, core concepts in information and scientific literacy.

I am also delighted to report the results of the 2001 Campus Campaign. Last year, gift and deferred receipts from the current and retired faculty and staff totaled a record-breaking \$10.4 million. This brings the total giving by faculty and staff, since the Campaign's inception in 1985, to an astounding total of more than \$78 million. I understand that this is the highest total of any faculty/staff campaign in the nation and reflects very positively on the commitment of our faculty and staff to the University, even in these austere economic times.

We have also had good news in our efforts to strengthen Ohio's knowledge economy. The Industry and Technology Council of Central Ohio annually honors members of the region's technology community.

This year, three of the seven honorees were from Ohio State: Umit Ozkan, associate dean for research in the College of Engineering, was named "Outstanding Woman in Technology;" Dr. Mauro Ferrari, director of the Biomedical Engineering Center, was named "Outstanding Educator for Advancing Technology;" and Edward F. Hayes, former vice president for Research who died in 1998, was selected to the ITC Central Ohio Technology Hall of Fame.

Just yesterday, Governor Taft and Mayor Coleman joined us to dedicate the MicroMD Laboratory in the Science Village. This is a truly leading-edge facility in the high-potential field of advance BioMems that will help grow Central Ohio's knowledge economy.

Finally, I'd like to note some especially gratifying news. Part of being a great university is having state-of-the-art, aesthetically pleasing buildings and facilities. I'm pleased to say that the Columbus Chapter of the American Institute of Architects has presented design awards to a number of our recent projects, which include: the Science Village; the Innovation Center, which is also part of SciTech; the Longaberger Alumni House; and the restoration of Ohio Stadium.

Mr. Chairman and members of the Board, this completes my report.

--0--

February 1, 2002 meeting, Board of Trustees

Mr. Brennan:

Before we move on to the presentation, I want to acknowledge to Dean Alutto what a wonderful venue for our meetings. You are offering really ripe competition for Longaberger Alumni House as the site of our meetings. This is delightful, Joe, and thank you for hosting us this morning.

Dean Joseph A. Alutto:

You're welcome. Thanks for being here.

--0--

PRESENTATION ON FUNDING STRATEGIES

President William E. Kirwan:

This morning, Ed Ray, Bill Shkurti, and I will discuss strategies for funding our academic priorities. As part of these strategies, we will include our recommendations on undergraduate tuition levels for Fiscal Year 2003. I will provide context for our proposed funding strategies, Ed Ray will relate them to our academic priorities, and Bill Shkurti will follow-up with the essential fiscal details.

We have given this matter a great deal of thought. Recognizing that the development of an appropriate resource base -- aligned with our priorities, and, in particular, the setting of tuition levels -- is one of the most important things that our University -- and you as members of the Board -- do each year.

Our approach today is to present you with our best advice, irrespective of how others may view it. We believe that is our obligation to you and your expectation of us. We also believe that we must give you reasonable alternatives that would move us toward our common goal of creating one of the world's great teaching and research universities. We hope you will find our presentation and analysis helpful as you deliberate this very important matter today, given the importance of the topic and the need we know you will have to reflect on it beyond today. We are not asking you to take final action on our tuition recommendations until the March 1 Board meeting.

I will begin with the context for our discussion. You will recall that in December 2000, the Board adopted an Academic Plan that has been widely disseminated and supported on and off campus. As you know, that plan lays out a strategic path to academic excellence for the University that will benefit our students, faculty, staff, and the people of Ohio. Let me remind you just what these benefits are.

As a state and nation, we are in transition from an economy based on brawn to one dependent on brains. In a global-knowledge economy, information and talent are the raw materials of success for individuals, corporations, states, regions, and nations. Thus, the importance and value of a college diploma is rising steadily. States are engaged in an intense competition for the people, ideas, and innovations that will grow their economies, enlarge their tax base, create jobs, and improve the quality of life for their citizens.

Universities make an especially vital contribution to economic growth by: educating undergraduate, graduate, and professional students for productive lives in a knowledge economy; attracting and retaining faculty who add to society's knowledge-base and spark new ideas; and helping translate innovations and discoveries into commercial products and useful services.

PRESENTATION ON FUNDING STRATEGIES (contd)

President Kirwan: (contd)

For Ohio to prosper in this new economic age, it is essential that the state have a great teaching and research university. Indeed, for all of the reasons I just mentioned, there is no example of a state among the leaders in the knowledge economy that does not have a distinguished university. That is precisely what our Academic Plan is intended to create -- a leading teaching and research university at Ohio State.

As you know, we are already seeing impressive progress toward the goals of the Academic Plan. Student quality is up, retention and graduation rates are up, research funding is up, and the number of national awards for our faculty is up. Ironically, just at this moment of great advances, we have been dealt a serious blow. The state's economy is in decline, resulting in budget cuts on top of already inadequate funding.

We now face a choice. Do we allow the state's inability to invest in higher education at this time halt our impressive progress? Or do we take matters into our own hands, generate the resources necessary, and sustain our advance to the top tier of American's teaching and research universities? Do we allow a decline in state investment to deprive our students of an exceptional education? Or do we find the means to provide a learning environment for them that is on par with the nation's best? Do we continue to build a world-class faculty, producing discoveries and intellectual property that will advance our state and nation? Or do we allow our best and brightest to be lured away to other universities?

For us the choice is clear. We must make the difficult decisions to advance this University along its path toward excellence. We must strive to provide our students with an education second to none. We must demonstrate to our faculty and staff that this is a university that intends to compete with the very best. Any other choice would seriously undermine our impressive progress and ultimately be harmful to our state. Excellence at a university in this era of the knowledge economy is a precious thing, but it is also a fragile thing. If our momentum is lost, it could take years, perhaps even a decade, to restore.

Having made the determination that we must move forward, we recognize that our fiscal circumstances require us to focus on fewer priorities in the Academic Plan and internally generate the funds necessary for the chosen initiatives. We have declared competitive levels of compensation for faculty and staff to be our top priority.

We also have committed to three programmatic initiatives: 1) creating an exceptional educational experience for our students; 2) using state and federal investments in the biosciences to build excellence in these areas at Ohio State; and 3) establishing the Institute for the Study of Race and Ethnicity in the Americas -- as an important resource for our diversity initiatives.

This was the basis of my report to the Board this past fall when I announced a number of measures to reprogram existing funds in-line with our priorities. These initiatives and other continuing commitments will require \$53 million. In addition, we must now also address a base budget cut of \$20 million, which is equivalent to 400 FTE positions. Thus, the total required to fund our priorities and to address the budget cuts is \$73 million in continuing funds.

In order to generate these funds, our first step was to cut existing budgets. We are now in the final stages of reducing centrally funded initiatives by 10 percent,

PRESENTATION ON FUNDING STRATEGIES (contd)

President Kirwan: (contd)

reducing and reprogramming academic support programs by up to seven percent, and reducing and reprogramming college budgets by up to 5 percent.

Additional targeted cost reduction initiatives have been implemented. They include: increased health care co-payments; energy savings, through competitive bidding and conservation; and review of purchasing practices and computer systems. These reductions and reallocations total \$36 million University-wide. The nine percent increase in undergraduate tuition that we announced last year, together with planned increases in graduate and professional fees, will contribute another \$24 million, for a total of \$60 million. That leaves us \$13 million short of the \$73 million we need.

We have searched for other means to generate the \$13 million. In our view, further cuts in budgets beyond the \$35 million I have already described are not possible without compromising the quality of essential programs in the academic core of the University. Thus, we have reluctantly concluded that most of the \$13 million will have to come from additional tuition funds.

I am acutely aware that our recommendations come two days after the Governor expressed concern about tuition increases in our state and the potential of such increases could threaten affordability and reduce access. We agree with the Governor that affordability and access are extremely important principles and we have reflected these principles in the recommendations we are making to you today. We also believe that our case is persuasive on other grounds and look forward to your views.

We have identified three alternative tuition options, each of which would provide all or most of the needed funds that you will want to consider. Bill Shkurti will lay these options out during his presentation.

One factor that influenced us greatly was our advice to students last spring that resident undergraduate tuition would likely rise by nine percent per year for each of the next four or five years. We estimated that these increases would, over this period, move Ohio State from eighth place among state public institutions, to third or fourth place in tuition level.

Given our role and mission as Ohio's flagship university, we think that a move of this kind is both reasonable and responsible. Even though circumstances have changed significantly since last spring, we remain conscious of the implied commitment we made to our current students. Consequently, we propose to place the responsibility for the additional tuition increases, beyond those already planned, on incoming students who have a greater opportunity to make choices and plan ahead.

We ask you to think of this as a one-time adjustment in our tuition, which almost everyone agrees is artificially low relative to the tuitions at other universities in Ohio. The proposed tuition level for entering students would be the base for future entering classes, with future tuition increases moderating significantly. The approach we propose is similar to one that is working well at the University of Illinois and that is likely to be adopted by Purdue University. We are convinced that it will work here at Ohio State, also.

With that in mind, today we recommend an annual undergraduate tuition level of \$6,417 for new students or \$1,200 more than our previously planned and discussed recommendation of \$5,217 for current students. Under this proposal,

PRESENTATION ON FUNDING STRATEGIES (contd)

President Kirwan: (contd)

our original commitment of a nine percent increase for continuing students would remain intact.

As Bill will explain in just a moment, this recommendation will move tuition levels for newly entering students next fall to third or fourth from the top among Ohio's public universities. Thus tuition for entering students would be well within the range of tuitions charged at other Ohio universities. Tuition levels for current students would remain well below the median in Ohio.

As we did so successfully last year, we will make the necessary adjustments to our need-based aid so that no admitted student will be turned away for financial reasons. I want to emphasize this point. The Governor most appropriately wants to keep our universities affordable and accessible, and so do we. That is why, once again, we have tied enhanced financial aid to increased tuition. In fact, the equivalent of 30-40 cents of the differential tuition money from new students would be placed into financial aid.

In considering our financial plight, we also sought comparative resource data from other schools: our aspirational peers, in the Big Ten, and in the State of Ohio. We found that top universities in other states receive about 20 percent more in revenue from all sources for each full-time equivalent student than does Ohio State. Relatively low state support in Ohio, combined with relatively low undergraduate tuition at Ohio State, has created an educational expense gap of almost \$1,000 in tuition and state support per undergraduate student, when comparing Ohio State with average support of our benchmark universities in the Big Ten. If we do not take some kind of action along the lines we present today, this disparity will grow presenting us with an ever-greater challenge in providing a competitive learning environment for our students.

It is also important to note that compensation for faculty and staff at Ohio State lags significantly behind benchmark institutions and in relative terms is falling. Once again, I must emphasize that outstanding faculty and staff are the *sine qua non* of a great university. Retaining the best faculty and staff is essential if we are to provide students with the highest quality education and do the research that will help position Ohio as a leader in the knowledge economy. That is why we have made competitive faculty and staff compensation our top priority.

Thus, as undesirable as it is, we see no alternative to raising this additional \$13 million and we see no practical means of doing so other than through additional tuition funds. Nothing less than the quality of our University and its ability to address important state needs is at stake. I want to stress that undergraduate tuition represents less than 40 percent of the solution to the \$73 million problem we face.

In conclusion, let me say that quality comes at a cost. It is essential that in March we take the action I have just outlined or some alternative version that Bill will discuss in a few moments. To do otherwise will do enormous harm to the quality of the University and, thereby, enormous harm to the future of Ohio.

We realize these are difficult times and that the funding cuts and tuition increases will be hard on all of us – students, faculty, staff, and friends of the University. We also realize that for some families it will create additional financial challenges. But this is something we must do for the good of the University and for the future of Ohio.

Now I ask Ed Ray and Bill Shkurti to continue this presentation.

PRESENTATION ON FUNDING STRATEGIES (contd)

Provost Edward J. Ray: [PowerPoint Presentation]

Thank you, Mr. President. I think those opening remarks were very helpful. Let me start with some amplification on many of the points that the President made.

The topic of the day is to discuss tuition increases for next year, but this is really a discussion about the mission and goals of the University. It is about the fiscal challenges that we face, about all of the alternative paths we can follow and to husband the resources together that we need to deal with that fiscal challenge.

Tuition is a piece of it. As the President mentioned, for the problem as we've identified it -- the \$73 million -- the tuition piece is less than 40 percent, but it's a critical piece of it. Let me start out by giving you a sense of what Bill and I will talk about, so we can get on to your questions and answers.

We want to talk a little bit about the goals of the University and the challenges that we face. We do want to spend some time talking about the details of what we recommend, why our recommendations are as they are for tuition increases, the implications of what we've talked about, and what we perceive as the appropriate next step.

Let me start first with what our strategic objectives are for the University and why. As the President said, to be successful in the 21st century Ohio needs a strong system of education, including a top tier comprehensive teaching and research institution. The President has talked about this quite eloquently on a number of occasions.

To remind ourselves, such an institution is critical. It provides an opportunity for talented high school graduates in Ohio, to learn and grow in a research environment that gives them a competitive edge in the knowledge economy. It's important because it attracts talented faculty and students to Ohio, from all over the world. It serves as a catalyst to grow the state's economy, which provides more and better jobs for all of Ohio's citizens. It serves as a focal point for a variety of activities that improve the quality of life for all Ohioans.

What needs to be done? Comparisons with the best public universities show that Ohio State University does a very good job, but we need to do a better job in a number of areas in serving our undergraduate students. Some of those areas are: retention of top faculty and support staff; increased direct involvement for undergraduate students with regular faculty; better access to high-demand courses; improved academic and career counseling; wider availability of state-of-the-art learning technology; more learning and service experiences outside of the classroom; and a more supportive physical environment.

Why do resources matter? We're all bright enough to understand that throwing resources at problems is never the solution. But it's important to realize the situation we find ourselves in and try to address the new financial problems that we face.

The President mentioned it already, but if we look at top institutions in other states we find that, on average, we have 20 percent less in resources available to us per student FTE here on the Columbus campus. We have relatively low state support and low undergraduate tuition, and that alone accounts for a gap of approximately \$900 per undergraduate student FTE. We fear that disparity is likely to get worse if we don't take some substantial action in the near future.

PRESENTATION ON FUNDING STRATEGIES (contd)

Provost Ray: (contd)

We've looked at a number of other alternatives. We've talked about cuts, set up mechanisms to do reallocations, and we think that we now have to turn toward tuition to help us deal with the problems that we face.

As a brief reminder, the state share of instruction per student FTE on the OSU Columbus campus was \$7,285 for FY 2001; for FY 2003, it will be \$6,887 – a decline of \$398 per student. If one multiplies that by the approximately 30,000 student FTEs that we have at the undergraduate level, we're talking about an absolute reduction, in dollar terms, of approximately \$12 million.

If we look at where we stand against other Ohio universities that are more selective in their admissions policy, what you observe is with our current tuition of \$4,788, we are \$1,253 per student FTE below the average. Again, if you multiply that by the approximately 30,000 undergraduate FTEs that we have here in Columbus, we're talking about a differential, in terms of available funds, of \$37.6 million.

Trust me, I'm an economist and I know that throwing resources at problems is never in and of itself a solution. When one starts looking at numbers of that magnitude, resources do make a great difference. It's from that base that we're now launching this discussion about what we need to do with respect to redirecting existing resources and finding new resources to move into the future.

The President mentioned that on average, we're 20 percent below benchmark institutions with respect to funding per student FTE. That translates into specific categories of support: in student services, service learning, career counseling, and so forth – areas that we try very hard to be competitive in – we're nine percent below our benchmark peers; in scholarships and fellowships, we're 31 percent below; for the physical plant, we're 36 percent below; in academic support, instructional technology, and other learning resources, we're 39 percent below; and in research, we're 47 percent below. So there are some really significant impacts associated with that overall 20 percent figure.

We think we've done about as much as we can with respect to finding alternative ways to generate the resources that we need to meet the \$73 million challenge that the President has already indicated we face for next year. In Spring 2001, Ohio State made a strategic decision to hold back on faculty and staff pay raises for FY 2002, in order to protect student and instructional programs. In recent months, you know that other state universities have done mid-year tuition increases and a number of universities have announced layoffs and eliminations of programs.

When we knew what the budget situation would be for FY 2002 and had an idea what we were facing for FY 2003, we felt that the responsible thing to do was to step back and do the minimal increases. We looked hard at how we were managing existing resources and made hard decisions.

We are committed to making sure that we make meaningful progress with respect to the kinds of salaries that we're able to offer our faculty and staff. We made a commitment that, on average, we hope to provide what the market provides on average -- the competitive salary increases -- plus one percent for faculty and staff for each of the next several years, in order to bring ourselves up to the midpoint of the benchmark peer group that we've identified for ourselves.

PRESENTATION ON FUNDING STRATEGIES (contd)

Provost Ray: (contd)

Another meaningful indicator of how the times have changed is that for FY 2002, state support fell below student tuition income for the first time in this University's 131-year history. As a comparative measure, in 1987 the ratio of subsidy state instructional support to tuition dollars was about 2:1; now it's slightly less than 1:1.

As we've discussed on many occasions, we're changing the way we do the budget process. We are providing colleges and support units with incentives to increase their revenues and reduce their costs consistent with the Academic Plan. We are also looking at other ways to maximize resources: private giving was up 17 percent for 2001; and sponsored research was up 18 percent. We've looked seriously at the kind of charges we could load on to non-general fund units. Central support services, athletics, and other areas provide \$28 million to the University. We're continuing to try to do other things.

The President already mentioned the commitments that he made in his October address to the Senate and to the Board of Trustees. A 10 percent cut in central investment funds, which translates roughly into a \$4 million reduction. Support units are to reduce or redirect their resources on the order of 3.5 to 7 percent for FY 2003, which translates up to \$14 million. Additionally colleges will reduce or reallocate from 2.5 to 5 percent of their budgets, which will add up to a potential \$18 million.

We're also targeting health care benefits costs and increased co-pays for FY 2002. We're looking at purchasing practices for key commodities, energy saving through competitive bidding and conservation, and ways to consolidate costs on new University-wide computer services.

So where does that get us? The University faces a \$73 million general fund problem for FY 2003, with \$20 million of that associated with the reduction in the general fund monies from the state, including the Success Challenge. As we indicated, we also have a critical need to provide competitive compensation increases for faculty and staff that will require \$30-\$34 million.

We have scholarship and financial aid requirements that we have to provide. The President was very clear that we augment our financial aid every year to assure that students, who otherwise are qualified to be here at Ohio State, are not barred from being able to continue with their studies because of economic need.

We have many other program costs that continue to increase over time, commitments to: Selective Investment, academic enrichment, and enhanced recruiting efforts. We also have legal mandates, physical facilities costs, etc., that range from \$8-\$11 million.

If one takes the midpoint of those figures – compensation, scholarships, financial aid, and the others – the total is \$53 million, and that added to the \$20 million is \$73 million. Now to tell us how we're going to deal with that is Bill Shkurti.

Mr. William J. Shkurti:

Thank you, Ed. President Kirwan outlined the general strategic objectives we're trying to achieve and Provost Ray outlined what the costs are and what the competitive disadvantage we suffer, compared to the people we're competing with, for the best faculty and students. I'll now outline where the money will come from and what options we've looked at.

PRESENTATION ON FUNDING STRATEGIES (contd)

Mr. Shkurti: (contd)

President Kirwan and Ed both addressed this, but there's one point I want to stress. I can't tell you how many people have told me in the last three or four days, "We were downtown and talked to different people that are associated with state government. They think you guys aren't doing any cuts, you just pass on whatever cuts the state has to your students in the form of higher tuition."

Having worked for the state for 13 years myself, I realize that sometimes the state is somewhat skeptical of what goes on out in the provinces with state money, and that's appropriate. But I can assure you that the \$20 million that occurred in state cuts to the Columbus campus are being cut out of budgets. These are not Pentagon cuts, where we take inflation and subtract it – these are real cuts. If your budget this year is this, your budget next year is this minus. So the \$20 million is coming out of the institution and that's real. As President Kirwan mentioned, that translates to 400 full-time positions.

We're trying to maximize taking away unfilled positions so we don't get into the cost and difficulty of layoffs, although we won't be able to avoid that. But we started out with real cuts, not with passing on costs to our students.

The second element is \$16 million in additional reallocations and other revenues, and I probably need to explain what that means. Other revenues are some other sources of income. For example, if we charge the auxiliaries for the services they get from the central campus, the growth in those charges will be \$1 million.

We've also told the deans and vice presidents that they need to meet the compensation goals that the University has set for their faculty and staff. We will be able to provide them with a little bit of money, but the rest of it has to come out of their budgets. We do not call that a budget cut, centrally.

When Ed and I met with the deans and we told them that, we got nasty looks. We were told, "You may not call it a cut, but it's less money than we're going to have to do other things -- so to us it's a cut." You can take your pick – it's either a redirection or a cut on top of the \$20 million. So it is at least another \$10 million in that regard.

After exhausting then what we thought we could get out of budget cuts, and additional reallocations and other revenues to minimize the impact to students, we took a look at what we had previously planned in the way of tuition increases. As Ed mentioned, we told the undergraduates last spring we were looking at a 9 percent increase a year for the indefinite future. We had also been looking at a 5 percent increase a year for graduate and professional tuition, which tends to be a little higher and closer to market. So you plug that into the formula and that is another \$24 million.

You have cuts, redirection, and planned tuition increases, but that still left us \$13 million short of the \$73 million solution. So let me talk about some of the options that we considered.

The first option we considered is that if we're \$13 million short, let's do the cuts we need to get through this. As both President Kirwan and Ed mentioned, we think the cuts we've already proposed -- the \$20 million in hard cuts and the additional \$16 million in redirection and other revenues -- are pushing our ability to provide core services to our students about as far as we can go. We think it would be detrimental to the future of the institution, to the City of Columbus, and to the State of Ohio, if we push that further.

PRESENTATION ON FUNDING STRATEGIES (contd)

Mr. Shkurti: (contd)

Then we thought if we don't do cuts, what if we make up all of the remaining dollars by increasing student tuition across-the-board, and that ended up approaching 20 percent. We simply thought that would not be feasible. It would be unfair to our students and would create problems with them being able to graduate on time.

So we looked at some other options and these are on page 14. Again, these aren't the only options we looked at, but it gives you a flavor of what we're trying to do.

Option A shows us holding all current students at 9 percent and puts the burden on new students. This is a version of the Illinois plan that President Kirwan had mentioned. That would be -- on top of the 9 percent increase for any new student entering in the fall -- an additional \$1,575 per new student. This would take our tuition for new students very close to what it currently is at Miami University.

Option A would solve our budget problem, but we thought that would be too much of a burden on new students. We were also concerned that there is a competitive market that goes on for students and there are really two parts to it: 1) the quality of the educational experience that you're offering; and 2) the cost. Frankly, we thought an increase of that amount would price us out of the market for students we thought that we would want to come here even with financial aid. So we rejected that option and decided to look at a different one.

In Option B, we bumped up the across-the-board increase for all students, including the current students, to 12 percent. Then took down the increase above that for new students to \$999, which would put them at \$6,357. That gets us the \$13 million, but our concern was it is still more than the 9 percent we had talked about last spring and would be a burden on our current students. Is there another way to put this together?

In Option C, we would keep the increase for all current students at 9 percent and then for new students at \$1,200 above that, which would put them at about \$6,400. This would get us \$11 million of the \$13 million that we're looking for and that is what we're recommending today.

There is no ideal solution to this. Unfortunately, this is the worst of both worlds. We have to talk about real budget cuts and reductions at the same time we're talking about tuition increases. But it's something we need to do to keep this institution viable in the future.

As President Kirwan and Provost Ray mentioned, this is our recommendation because we think this is the best balance of all these options. We realize there may be other ways to put this together and we're open to additional suggestions. We are not asking the Board to vote today, but we do need to make a decision by March 1 so we can let students know who are coming here next year what their tuition is likely to be.

Let me talk a little bit about this recommendation. I think the driving force is that we need to maintain our commitment to enhancing the academic quality of this institution, even during difficult economic times. We also need to continue to do all we can internally to reduce costs and reprogram revenues.

I think some of our colleagues at the state-level view us as a public utility of 20 years ago, where they would say, "Our natural gas prices went up, so we're just

PRESENTATION ON FUNDING STRATEGIES (contd)

Mr. Shkurti: (contd)

going to pass them on to consumers.” We’re not in that business anymore, and we recognize that we have to do better in managing our resources.

We also recognize that our tuition policy should be as fair as possible to our current undergraduates who came here assuming a certain set of conditions and who we are encouraging to graduate as quickly as they can. We need to protect our students financially as best as we can.

We need to increase our financial aid. I strongly support the statement President Kirwan made that we share the Governor’s concern about the impact of what we’re doing on people who cannot afford to pay. We’ve been very aggressive in raising student financial aid. We did it last year and we’re committed to doing it again this year.

Finally, a high priority for the use of the increased resources will be to preserve and improve the quality of the student experience, both inside and outside the classroom.

President Kirwan talked about the details of the recommendations, so I’ll briefly touch on them again. We are recommending a 9 percent increase for instructional and general fees for current students to begin Summer Quarter 2002. We did not do a middle of the academic year increase, but to make up some of this money we need to get this implemented.

Then for new students, the increase of \$1,200 per year would begin Autumn Quarter 2002. We define new students as any undergraduate student starting at Ohio State in Summer Quarter 2002 or later. This means if someone came here for a couple of quarters, dropped out and then comes back, they would pay the old rate, not the new rate. We want to encourage them to finish their education. We’re also treating as Ohio State students, students currently enrolled at the Regional Campuses. So when they transfer here, they would transfer at the lower rate for current students, not the higher rate for new students.

We’re telling current students they would be grandfathered, or exempted, from the new higher rates for four years, through 2006. So with every new class, more and more students will pay the higher rate. Four years from now, everyone would pay the higher rate.

These recommendations apply to the Columbus Campus only. We want to give the Regional Campuses an opportunity to talk about how they want to deal with this issue and then bring forward a recommendation.

As we said earlier, student financial aid will be increased more than proportionately with the increase in tuition. This will make sure that any student who is otherwise qualified to attend this University will be provided access. This point is very important.

These recommendations are based on the levels of state support and House Bill 405. That was the budget balancing bill that was passed and signed by the Governor in December. In essence, if these levels change, all bets are off. We absorbed the cuts in mid-year from the state and protected our students by using our Rainy Day Fund and other resources. Some other universities didn’t. We’re not in a position to guarantee that we can do that again, so we’re all vulnerable to changes in the economy.

PRESENTATION ON FUNDING STRATEGIES (contd)

Mr. Shkurti: (contd)

Even if we adopt these recommendations, it means we have to identify another \$2 million. This only raises \$11 million through a combination of spending reductions, reallocations, or income increases. We're looking at some options to do that and will come back to the Board at the March meeting and talk about it.

Finally, a point President Kirwan made that I think is extremely important, is that this is a combination of budget reductions, reallocations, revenue increases, and undergraduate revenue increases. All of these that we're proposing account for no more than 40 percent of the total solution to the problem. If you then throw in professional and graduate student increases, it's still only about half of the problem. About half of what we're doing to solve the problem is hard budget cuts, redirection, and reallocation of resources, and the other half is additional revenues.

After all this happens -- if we implement the recommendations we've talked about, which is the 9 percent for current students and the additional \$1,200 on top of that for new students -- where will that put us compared to comparable institutions? We have to make some assumptions here because we don't know what all the other universities are going to do, but we have a pretty good idea.

If you assume all the Ohio universities increase their tuition in the fall by 6 percent -- except for Ohio University which has announced a higher rate -- we would still remain eighth out of thirteen in tuition for our current students. We're right in the middle of the pack. We would be fourth out of thirteen for new students. We still would not be the highest-priced institution in the State of Ohio, even though we are a comprehensive research institution and we feel we are the academic leader of this state.

I've talked to many of my counterparts at other Big Ten universities and a number of them have already announced what their tuition plans are for the fall. If we compare ourselves to the public Big Ten and assume the institutions that haven't announced will increase their tuition by 10 percent, then we would remain seventh out of ten for current students and fifth out of ten for new students. So we would be right smack in the middle.

If you look at the benchmark institutions -- our aspirational peers, which include some Big Ten public schools and some that are not -- OSU would rank fifth out of ten for current students and fourth out of ten for new students. Again, we would be right in the middle compared to those institutions.

At this point, I hope you have a sense of both the nature of the challenges that face us, the options we looked at for dealing with these challenges, and the recommendations we made and why. I'll now turn this back to my colleague, Ed Ray, who will talk about the implications.

Provost Ray:

I want to make a few quick points and then we will get to the question and answer session. Let's talk about what happens next.

As we indicated, we hope that the Board will be able to make a decision on March 1 regarding tuition for next year's continuing and new students, so that they can be prepared for next fall. I want to remind you that all other fees and charges will be determined later in the spring as part of the regular budget process. Again, decisions about how funds get distributed will be dealt with through the normal budget process in late spring and early summer.

PRESENTATION ON FUNDING STRATEGIES (contd)

Provost Ray: (contd)

Again, the caveat that Bill issued is that this is all dealing with reality as we know it. If there are additional surprises down the line, we may have to talk about yet other actions to be taken.

Let me stop there and turn it back over to President Kirwan and Chairman Brennan.

Mr. Brennan:

Thank you very much. Although there is no motion to be presented today, we're open for discussion among the Board. Are there any questions for the panel?

Mr. Sofia:

Bill, with the proposal you are making -- I'm just speaking of the institution with the highest tuition -- it looks like Miami University would still be about 30 percent higher than Ohio State for all students, and about 15 percent higher for new students.

Mr. Shkurti:

That sounds about right.

Mr. Sofia:

The reason I'm making this distinction is that as we all know, Ohio State ranks higher than Miami University. At the same time, a lot of students associate quality with what you pay. Perception is a reality. I just wanted to make that observation. I don't know of any other school that has the quality we have and that is so affordable to so many students.

Mr. Brennan:

Thank you, Zuheir. Dan --

Mr. Slane:

Bill, are the recommendations predicated on state support in the future staying the same?

Mr. Shkurti:

Staying the same at least for the remainder of the biennium or meaning what it is after the Governor's cuts. We're assuming the executive cuts the Governor made this year will be rolled over to FY 2003. That is correct.

Mr. Slane:

Is it reasonable to assume that since state support has been cut at least for the last three years, that it's going to continue down?

PRESENTATION ON FUNDING STRATEGIES (contd)

Mr. Shkurti:

That is probably the thing I worry about the most. We're in a dynamic situation and right now the economy looks to be recovering, but that could change next week. That is why I said when I was talking about House Bill 405, that if for some reason the state gets back into financial trouble and turns around and passes on additional reductions to us, all bets are off. Then we will have to figure out what to do next.

There is no way the state can guarantee us that they'll not reduce us in the future. That is something we need to think about as we do reductions now and also as we plan ahead. What would happen if there is bad news down the road? I don't want to be a Cassandra – things could work out fine and we could be okay, but there's no guarantee that would happen.

If you look at the other recessions the state has been through, I particularly worry about the one that lasted from 1980 through 1983. It's called a double-dipped recession. It looks like you're coming out of the recession and then you fall back in.

The other thing I worry about is the budgetary Pac Man called Medicaid. This is an entitlement program that is caseload driven and tends to be a lagging cost after the economy turns around. No matter who has been in charge or who the administration is, it has been a struggle to keep the costs of that program under control. The economy could recover, but if Medicaid expenses can't be controlled, that could create budget problems as well.

In those circumstances the Governor has no choice, the Constitution requires a balanced budget. The Governor can only cut by Executive Order, unless he can convince the legislature to raise revenues and that is very difficult. You now have a problem this Governor and Governor Voinovich had that previous governors did not -- the DeRolfé decision. When in effect, it will take off the table over a third of the state budget for K-12. So that puts us in a somewhat precarious position and why, as we think through solving the problem today, we need to think ahead.

One of the reasons that we agreed to recommend the two-tiered approach on tuition is that it builds in a steady source of income from students who choose to come here. If you phase it in over a number of years this income can be invested in improving the institution.

Mr. Brennan:

Jim --

Mr. Patterson:

Bill or Ed, some clarification on the question of compensation. There is some significance to it because it's approximately 50 percent of what the \$73 million that we're showing as needed. My bias is that we're a very good institution and there are some people that say that we're a good institution. I don't believe there's anyone in this room that would disagree with the fact that our goal is to become a great institution.

That being the case, is the compensation -- the \$30-\$34 million -- just for raises? Or is it compensation to attract outstanding faculty and staff? Or is it compensation to have the appropriate number of instructors per student? I am totally supportive of the compensation raises, so that's not the question.

PRESENTATION ON FUNDING STRATEGIES (contd)

Mr. Patterson: (contd)

Bill, you said the \$20 million that we cut is going to result in the loss of 400 positions. Is this \$30-\$34 million based upon that lower number or is it based upon another number? I think, it's 50 percent of our reason for the \$73 million and so we need to have a basis for it.

Mr. Shkurti:

Mr. Patterson, let me answer your last question first and then turn to Ed for answers on the broader issues. The reason we provided a range is that we're rather early in the process. We don't know the impact of all the reduced positions, so the lower end of the range would assume some reduction of positions. On the other hand, we haven't assumed a lot of new hires in that. That's essentially to provide a market-level increase for the people that are here or that will be here after the beginning of the year.

It also includes about \$12 million for benefit increases and health insurance benefits are going up again this year. When you take the \$12 million out, that leaves a little over \$20 million for pay increases. So compensation is both pay and benefits. I'll turn to Ed on the issue of hiring additional people.

Provost Ray:

The dollar figure is really associated with compensation for current faculty and staff. There is some range because there could be some modest change in that. If you remember, we said that first and foremost we need to recruit and retain world-class faculty to achieve our objectives with respect to the Academic Plan.

While these represent compensation rates that we think we need to meet in order to retain our faculty -- particularly in light of the minimal increases this year -- those compensation figures are always based on merit only. That sends very powerful signals as we go out into the marketplace and try to recruit new faculty. Faculty know what their colleagues' capabilities are and what our compensation packages look like, and that has an impact in the future in terms of their willingness to consider coming here. How we treat our people here who do accomplish things and are highly capable, sends a signal to outstanding scholars that we hope to bring here. It is an important signal to send.

Ms. Longaberger:

What are you anticipating as the impact on enrollment with these recommendations?

Provost Ray:

In adding new and transfer students to the University rolls, we think that we can hold the quality measures with justifiable pride, such as ACT scores -- students in the top 10 percent of their graduation class. We can hold those quality measures constant and still meet our enrollment targets of 5,800-6,000 new fall quarter freshman. In part because we're getting better at encouraging and enticing students to want to come here, and because other institutions are having to raise their tuition as well.

Ms. Longaberger:

You read in the papers everywhere that when people are not able to find jobs that they go back to school. I wonder if we're putting enough money in financial

PRESENTATION ON FUNDING STRATEGIES (contd)

Ms. Longaberger: (contd)

aid, given all of the laid off workers that we have throughout the country that may be considering developing themselves. As universities raise tuition rates, it would be a real challenge for them to make that up, particularly when they're unemployed.

Provost Ray:

There are really two aspects of that. Again, to remind all of us that as the President indicated, 30-40 cents on every dollar that we raise through these tuition increases will be put into student financial aid. We understand that as the price goes up, the issue of access and affordability becomes a critical one. We've had experience and have been doing this for a number of years. We know that with that kind of commitment to financial aid, we can be well assured that students who are otherwise qualified to be here, can afford to be here.

There is a longer term issue, not just for people who may be coming out of the workforce and going back to college, but people who are having trouble in the workforce who have children who want to go to college. Part of what we have to remember is not to be too short-sighted. We really have to keep our sights on what we're trying to accomplish in the long term and help the state accomplish. If we can help the state have a better, more vital, and stronger economy, then, in fact, the children of those who are having difficult economic times now won't have such difficult times in the future, given the kind of educational tools we can give them. Bill –

Mr. Shkurti:

The other element of this is really interesting. I asked Tallie Hart, director of Student Financial Aid, what happens when a person is laid off and what is the process? Tallie confirmed that either the person or their children do become eligible for financial aid.

She said one of the major problems we have is communication. The federal form for financial aid that everyone fills out is based on what the person's previous year tax return was, because that's the way they verify the income. She says we have a process for waiving that and taking into account the change in circumstances, but a lot of people don't understand that. We encourage them to come in to the office for help.

It also does not help when we get headlines, "Tuition Increases X zillion percent," without any context. People think, "There is no way I can afford it," and they don't even try. So for the people who actually lose their jobs, we can help out with financial aid and that's why we're increasing it.

Then the people I worry about are people that are working at a level where they're not eligible for financial aid, but are gainfully employed. This is a struggle throughout the whole system. That is why we tried not only to provide enough money to help the people on the lowest end, but to expand the amount of financial aid that's available -- either with University general funds, private fundraising, or merit-based aid. There are also some substantial increases in federal aid.

Fortunately, we have a way to help laid off workers directly, but it is a communication issue. We need to work through the lower-middle end of the economic spectrum.

PRESENTATION ON FUNDING STRATEGIES (contd)

Mr. Sofia:

Mr. Chairman, a follow-up to Tami's question. We talked about access, affordability, and fairness – the \$1,200 we're going to charge a new student, who is sitting in the same classroom with a current student. Tami mentioned that we have a large number of people unemployed in Ohio, and those people are going to be sending their daughters or sons to Ohio State as a new student. How do you address that issue?

Provost Ray:

Part of the answer to that is that the new students will be here four years, certainly no more than five years. For the continuing students, they're not going to be here as long. So to the extent that we make good use of the resources that we bring in -- to increase advising and counseling, to deal with closed course problems, to provide more faculty instruction in high-demand areas, and to bring more technology to bear on the classroom -- those students who are paying more for that longer period of time will be greater beneficiaries of the changes we're able to afford, than those who are already here and continuing students.

President Kirwan:

There is one other point to make to that, Zuheir, and that is that the student has made a choice to come knowing what the circumstances are. To impose and go beyond where we had intended to be for current students, to me that is unfair. The new students are making the choice.

Mr. Patterson:

Will the \$1,200 differential just be in place for four years -- if a person stays five years ...

Mr. Shkurti:

Yes, but it is less people each year.

Provost Ray:

Then everyone will be at the same rate.

Mr. Brennan:

Tami, I believe the thrust of your question and thought was, "Would this impact enrollment because of the increase and would financial aid be sufficient?" I believe we've had experience with that, haven't we? What has happened?

Mr. Shkurti:

We asked ourselves that same question when we increased tuition nine percent last year, but our enrollment was up in the fall. That was a good sign that students are reacting well to the kind of university that we're providing and also to the financial aid package.

We've talked this over with our enrollment people and they are a little skittish about the \$1,200 in terms of recruiting. They recognize it's a calculated balancing between the sticker price that we're offering new students and what we're able to offer them in the way of services and personal attention and being able to get the classes they need.

PRESENTATION ON FUNDING STRATEGIES (contd)

Mr. Shkurti: (contd)

As I mentioned when we talked about options, the reason we did not want to go above \$1,200, is that we thought of the enrollment impact and of losing enrollment would offset any advantages we had there. The \$1,200 pushes it a little bit. In a perfect world it would nice if we didn't have to do that, but we don't live in a perfect world. We're trying to balance things.

Ms. Longaberger:

You mentioned that the Regional Campuses will have the opportunity to discuss the tuition increase. What about out-of-state students? You didn't mention graduate or professional students?

Mr. Shkurti:

First, let me deal with out-of-state undergraduate students. The way our system works is these students pay what the in-state students pay, plus a surcharge on top of that. So all of these increases we are talking about -- the nine percent and the \$1,200 -- will be paid also by the out-of-state students. In addition, we're programming the out-of-state surcharge to increase another five percent on top of that.

Up to now one of the challenges we have is that with the way the state deals with tuition caps -- which is the Soviet-style, one-style-fits-all -- our undergraduate resident tuition is way below market of competing institutions. The tuition we charge for graduate and professional students and out-of-state students is at market. We don't see a lot of room to maneuver there without causing ourselves enrollment and fairness problems.

On the other hand, we are going to go back -- because Mr. Sofia had asked this at a previous meeting -- and take a look at the out-of-state fees compared to other places. To get a better sense of what other institutions are going to do and make sure we're at least charging as much as we should be. There is a fairness issue in that the students that are here are supported by the taxpayers. This cuts two ways because the students we bring in from out-of-state are undergraduates, receive no state support, and, in fact, pay about twice what the state pays us for the in-state students.

It is an interesting situation. As a state institution we have our greatest loyalty, and should, to the people of Ohio, and to their sons and daughters. We benefit financially if we have more out-of-state students because of the way the state reimburses us. That is an important thing to keep in balance.

President Kirwan:

I want to make a brief comment on the issue of what will this do to our competitiveness with new students. At least for in-state students -- which are the bulk of our students -- our main competition is Miami University, Ohio University, and Cincinnati. These institutions will all have higher tuition than our new students would face. In relation to our major competition, we would still be under their cost.

Mr. Brennan:

Jo Ann --

PRESENTATION ON FUNDING STRATEGIES (contd)

Mrs. Davidson:

On page twelve, I draw the assumption that the dollar amount that you have in scholarships and financial aid is based upon making up the entire gap here of \$13 million with some type of tuition. So if there was a different decision made, whatever it might be, to not do that, than that line item would decrease.

Mr. Brennan:

That's correct.

Mrs. Davidson:

So that could conceivably be a lower number.

Mr. Brennan:

Only in part. The \$24 million, which is a carryover, also has a substantial financial aid piece to it, probably two-thirds of that.

Mrs. Davidson:

Right. But if my math is correct, you're basing it on thirty percent of your \$24 million, plus \$13 million. Therefore, you would have a decrease if there were other decisions made. I just want to be sure I'm understanding this correctly.

Provost Ray:

Correct. If it is costing you forty cents on the dollar to get a dollar of revenue, you can save forty cents, but you lose a dollar's worth of revenue. On balance you end up worse off -- you lower costs, but you lower revenues more.

Mrs. Davidson:

The second question I have deals with the other line, which we haven't discussed -- "All Other." Can you do a breakout in what we're talking about on "All Other?"

Mr. Shkurti:

Sure. We deliberately tried to keep this chart clean and simple for putting up on a screen, but it reflects about eight pages of computer printout. I will not go through all of those, but let me give you a flavor of what's in there.

There are really three different categories: facilities costs; multi-year commitments regarding quality from Academic Affairs; and then "Other." Let me give you a sense of each of those. In the case of facilities -- utility bills, insurance, debt service, and rent -- we're assuming about a three percent increase. That would be \$2-\$3 million, of the \$8-\$11 million.

On the OAA multi-year commitments, this is driven almost entirely by quality. It includes, for example: 1) the Selective Investment Awards that have been made, which are multi-year awards, and there is \$2 million set aside for that; 2) the rebasing of unit budgets, which is based on their academic contribution and a look at their finances. There is \$1.6 million that would go to colleges based on their contribution to the academic needs of the University, as determined by the Provost; and 3) a recruiting initiative trying to bring more academically qualified students to Ohio State, which is the remaining \$400,000. That whole track is

PRESENTATION ON FUNDING STRATEGIES (contd)

Mr. Shkurti: (contd)

about \$4 million and is related to specific investments in quality that go through the Provost's Office that are consistent with the Academic Plan.

The third category, which I would call, the "Other of the Other," includes a program called, "Revenue Enhancements." This is where we've said to the professional schools, "You can raise your tuition above the normal five percent, as long as you have a discussion with your students, they're supportive of it, and you target it into improving your programs." We've been doing this for five or six years. We are showing that on the revenue side, as well as on the expense side, and that is \$2.6 million.

In response to Ms. Longaberger's question, we want to make sure we have the enrollments we need in these very tumultuous times. We have a \$1 million enrollment reserve set aside in there, so that gets you \$3.6 million.

Then the remaining \$500,000 is what we call, "unfunded mandates." We have found that our political leaders of both parties – particularly, while they're running for election and right after they're inaugurated – say, "The one thing we're not going to do that the other guy did was pass on unfunded mandates to states, cities, and universities." They all say it regardless of their party.

About six months later, we start to get mandates of \$100,000 here and \$500,000 there. It is not frivolous stuff. It is environmental compliance -- we want to be a good neighbor to Upper Arlington and to the City of Columbus. It is Americans' for Disabilities Act -- so our University is accessible, but that is not cheap. It is different kinds of mandated benefits, the portability of insurance and so forth. My experience has been year in and year out that those add up to about \$500,000 a year.

It used to be that the University would say, "We don't like them, so we're not going to do them." The University would wait to get sued and it would get sued, and it would either lose the lawsuit or have to settle out of court for millions of dollars. So, we're trying to be proactive. I wish we didn't have to do it, but they're legitimate causes. We document those every year for the Board. So that is \$500,000, and that gets you to about \$4 million.

So you have \$2-\$3 million in facilities; \$4 million in the OAA quality enhancements, consistent with the Academic Plan, and \$4 million in the remainder; that gets you \$10-\$11 million. You may wonder then why does my chart show \$8-\$11 million.

After I did the charts, I thought that there is probably somebody who is going to ask me what those are and I better defend them. I've said we just don't pass on costs, so I lowered the facilities pass through by a \$1 million. I lowered the "Other," which includes the enrollment reserve by a \$1 million on the lower end just to keep it balanced. We could talk about University priorities, but I don't think there is anything that is frivolous in there that is not appropriate.

Mrs. Davidson:

Just a little defense to former and current governors and legislature, let me point out that every one of the things that you cited are federal mandates, not state mandates.

PRESENTATION ON FUNDING STRATEGIES (contd)

Mr. Shkurti:

Fair point, Mrs. Davidson.

Mr. Brennan:

I think his point was regardless of party, not which government.

Mrs. Davidson:

I was just relating it federal to state, Mr. Chairman.

Mr. Brennan:

Dimon --

Mr. McFerson:

I'd like to simplify things. I started my life as an accountant, so I have to keep things simple.

We have commitments, challenges, and some options. One of the three big commitments that I've heard is that we have a commitment to the faculty on compensation. I absolutely think we cannot, in any way, take that stake out of the ground. That is a firm commitment.

We have an implied commitment to the students that we're not going to raise tuition more than nine percent. That stake is in the ground.

We have an Academic Plan that we have talked about, our President has been far out in front of that, and this Board has been very supportive of that all along the way. We can't back off that, to do so would change the very nature of what we're trying to accomplish at this University.

The challenges are that the state right now is not very excited about a two-tier solution and we don't know if there's going to be any more budget cuts. We're hopeful that that will not be the case. So we have a \$13 million shortfall. Is it fair to summarize that it's a \$13 million problem?

Mr. Shkurti:

Gap.

Mr. McFerson:

Okay, we have a \$13 million gap on our hands. What are the options? You know we've all bought things and after you have the purchase price you have a shipping and handling charge. I don't think we want to get involved in a S&H charge around here, where we are nicked and dined. I suspect we could take a look at fees for everything and come up with a few million dollars, but there's no magic \$13 million fee standing out there. If there was, you would have presented it to us, so that's not an option.

We have the two-tier program that is working in other states that is an option for us, but it's a challenge right now. As you presented to us, higher tuition for everybody is an option. It goes against our commitments, but it's an option for us.

PRESENTATION ON FUNDING STRATEGIES (contd)

Mr. McFerson: (contd)

We can do some rather extensive budget cuts beyond where we are, but you've indicated to us, Bill, that we begin to cut into the muscle if we do that. As you pointed out maybe we can find, in your preferred option, at least \$2 million of additional cuts. An organization of this size can always find \$2 million. From my perspective, I don't think as an institution we can put it at risk by doing things that would risk where we want to go.

It absolutely starts with a world-class faculty. In the President's opening remarks he commented on some wonderful things that are happening here. At every meeting he talks about wonderful things that are happening with our faculty. That is where we have to always start and so we can't put at risk the progress that we've made there.

I see between now and the next meeting getting together with the state and trying to work out an acceptable solution. I don't know what that is, but in light of the commitments we've made, and in light of the challenges that we face, we have to close that \$13 million gap. There is no easy answer, but I applaud the administration for putting forth their best view of the problem. I think as Trustees, we have to recognize our stewardship is to this University and to stay in line with the commitments that we have made.

Mr. Brennan:

I'd like to add on just a thought to your last remark, Dimon, and that this is sometimes lost in the public view of what's going on right now. We hear often, that the state must balance its budget, which is true. So must we. We have a fiduciary obligation as Trustees to provide a balanced budget for this University. This is not an option. This is not something that we maybe can do. We have to do that.

Our obligation is just as compelling as the obligation of the state to balance its budget. I think that it gets lost in too much public dialogue on this. So whatever discussion we have, and I'm sure that will take place, it has to include that recognition.

Like you, Dimon, I like to get down to the snapshots. I'm intrigued by two numbers in this report that we have and I'd like to clear up one of them. I believe you mentioned on page 12, that we have a \$20 million shortfall in the state fund support. Then on page seven, you tell us that the undergraduate portion cuts \$12 million. I assume the difference is reduction and support because of the graduate program?

Provost Ray:

I'm sorry, Mr. Chairman, the figure on page seven was to suggest if one looked at what has happened in terms of just the state's share of instruction.

Mr. Brennan:

Definitely, but that much of the cut is undergraduate cut.

Provost Ray:

It's been cut the equivalent of \$12 million.

PRESENTATION ON FUNDING STRATEGIES (contd)

Mr. Brennan:

It's not appropriate to say that of the \$20 million, only \$12 million was undergraduate?

Provost Ray:

No.

Mr. Brennan:

One thing is clear though, that if the state had not cut us \$398 in instruction per student, we wouldn't have a \$13 million problem. That is clear, isn't it?

Provost Ray:

Absolutely.

Mr. McFerson:

If we had the opportunity for the same 9 percent increase that Miami had, the Miami dollars for us solves our problem.

Mr. Brennan:

That's true, too. This flash point we're facing is a creation beyond our control. All that is in our control is the discussion we're having this morning and we have a fiduciary obligation to make sure that we discharge that. I expect that's what we're going to have to do.

I'd like to make two other comments and then I'm sure there are other questions. I felt that one of the answers we ought to give to Tami's concern about enrollment was that our experience with financial aid under the 9 percent increase was that our reserve was more than adequate. Is that not correct?

Provost Ray:

Correct.

Mr. Brennan:

Our experience indicates that our people are pretty good at anticipating how much will be necessary and, frankly, that gives me quite a bit of comfort.

I'm proud of this Board and the time we've talked about these issues. We have all been very strong and forceful that we are obligated to maintain the ability to accept students who need financial help and that these increases will not impact them. I do not believe that is played up enough in the press, nor played up enough in the public awareness. We're dedicated to that and, I don't believe, we are not going to equivocate on that.

Finally, just as a footnote, I suspect that some people would say in this state that our leading university may be Case Western Reserve. Case Western is a private university and raised its tuition \$1,500 this year – now it is \$22,500 a year to attend. Any more questions from the Board? Kevin --

PRESENTATION ON FUNDING STRATEGIES (contd)

Mr. Filiatraut:

Thank you. You mentioned that the University of Illinois has done this, or a plan similar to what you are suggesting. I'm wondering what student reaction was to that plan? Also, I'm wondering if there has been any inquiry as to how enrollment was affected the first year after that plan, especially in regard to minority enrollment?

Mr. Shkurti:

I have talked to my counterparts at Illinois. They have told me that politically -- throughout the State of Illinois, both by current and future students -- there was no problem with the two-tier approach. They suffered no diminution of enrollment either generally or with minorities, and they felt it worked very well.

Now in fairness, I need to say they did it in two steps. They raised tuition \$500 the first year and then they will raise tuition an additional \$500 on top of that next year. We are going to be a little more aggressive than that. Fundamentally, they feel -- and I haven't heard anything to the contrary -- that it was very successful and got them where they needed to go.

President Kirwan:

I've had a number of conversations with Jim Stukel, President of the University of Illinois, basically confirming what Bill just said. They thought there was acceptance of it across the state, and that it had no impact on enrollment or the quality of the undergraduate student body.

Mr. Filiatraut:

I have one more question. We didn't see anything about how graduate and professional tuitions would be affected by this. In years past, there has always been a five percent increase. Is that going to increase?

Provost Ray:

That is part of the \$24 million that we talked about in terms of anticipated increases for next year. We talked about the 9 percent for undergraduates and 5 percent for graduate and professional students, as the anticipated tuition increases we would have for next year.

Mr. Filiatraut:

So, it's still at 5 percent for next year?

Provost Ray:

Yes.

Mr. Filiatraut:

Will the professional colleges still be able to price to market, as they have in the past?

Mr. Shkurti:

Yes. In fact, Ed and I sent out the memo a week ago to the deans for those professional schools that said, "If you can make a case that you are below

PRESENTATION ON FUNDING STRATEGIES (contd)

Mr. Shkurti: (contd)

market, that you work with your students, and this is an improvement you'll be able to make with this money, we will entertain a request which, in turn, we will recommend back to the Board later this spring." So that process still remains.

Mr. Brennan:

Any other questions?

Mrs. Davidson:

There were comments made in the presentation about the assumptions on budget reductions that included the elimination of a certain number of positions. Could you elaborate on this?

Mr. Shkurti:

We are talking about possibly eliminating 400 full-time equivalent positions. We would do this first by not filling vacant positions. We would also do this by not filling positions once people retire. We will do everything in our power not do any type of layoffs, but we probably won't be able to avoid that.

Mr. Patterson:

I just wanted to comment on Dimon's remarks. I agree with Dimon that in the next 30 days we need to rely on this leadership, the Chairman and the President, getting together with the state and trying to find a solution.

Mr. Brennan:

I agree. We have 30 days for this leadership and administration to talk and meet with state officials. I am confident there will be meetings arranged to come up with a final recommendation to bring to the Board at the March meeting.

This has been a wonderful discussion today and I look forward to future dialogue.

(See Appendix XXII for background information, page 783.)

--0--

CONSENT AGENDA

President William E. Kirwan:

We have seventeen resolutions on the Consent Agenda today and unless there are any objections, I would like to recommend the following resolutions to the Board:

ESTABLISHMENT OF A PH.D. DEGREE PROGRAM IN WOMEN'S STUDIES

Resolution No. 2002-67

Synopsis: Establishment of a Ph.D. degree program in Women's Studies in the College of Humanities.

WHEREAS over the past three decades women's studies has become a distinctive interdisciplinary field which has evolved into a doctoral-granting discipline; and

ESTABLISHMENT OF A PH.D. DEGREE PROGRAM IN WOMEN'S STUDIES (contd)

WHEREAS the Department of Women's Studies has strong M.A. and undergraduate programs which advance the field on a nationally recognized level; and

WHEREAS the department currently houses a distinctive faculty with excellence in the field of women's studies and a range of disciplinary strengths; and

WHEREAS the proposed program will prepare future scholars for academic positions and service to public and private agencies and institutions; and

WHEREAS there are less than ten Women's Studies Ph.D. programs in the United States and none in Ohio; and

WHEREAS the proposed program supports the institutional goal of increased attention to diversity in the student body and curriculum, and commitment to the education of women; and

WHEREAS the proposal adheres to all Office of Academic Affairs and Ohio Board of Regents Guidelines for Approval of Graduate Degree Programs; and

WHEREAS the proposal was discussed and approved by the Research and Graduate Council, the Council on Academic Affairs subcommittee, the full Council on Academic Affairs, and was approved by the University Senate at its January 10, 2002 meeting:

NOW THEREFORE

BE IT RESOLVED, That the proposal to establish a Ph.D. degree program in Women's Studies in the College of Humanities is hereby approved to be effective upon the approval of the Ohio Board of Regents.

**ESTABLISHMENT OF A MASTER OF OCCUPATIONAL
THERAPY DEGREE PROGRAM**

Resolution No. 2002-68

Synopsis: Establishment of a Master of Occupational Therapy degree program in the School of Allied Medical Professions is proposed.

WHEREAS the Bureau of Labor Statistics reports that occupational therapy will be among the fastest growing occupations; and

WHEREAS modern trends in health care and in occupational therapy practice call for professionals with graduate level education to be consultants, team leaders, supervisors, independent practitioners, and participants in research; and

WHEREAS the undergraduate program in Occupational Therapy has a national reputation as an exemplary program, has been productive in scholarship and research, and has a history of attracting very high-quality students; and

WHEREAS seventy-eight of 131 occupational therapy educational programs currently accredited by the Accreditation Council for Occupational Therapy Education (ACOTE) offer entry level master's programs; and

WHEREAS ACOTE has decided that as of January 1, 2007, it will only accredit post-baccalaureate occupational therapy programs; and

**ESTABLISHMENT OF A MASTER OF OCCUPATIONAL
THERAPY DEGREE PROGRAM (contd)**

WHEREAS the proposal adheres to all Office of Academic Affairs and Ohio Board of Regents Guidelines for Approval of Graduate Degree Programs; and

WHEREAS the proposal was discussed and approved by the Research and Graduate Council, the Council on Academic Affairs subcommittee, the full Council on Academic Affairs, and was approved by the University Senate at its January 10, 2002 meeting:

NOW THEREFORE

BE IT RESOLVED, That the proposal to establish a Master of Occupational Therapy degree program in the School of Allied Medical Professions is hereby approved to be effective upon the approval of the Ohio Board of Regents.

AMENDMENTS TO THE RULES OF THE UNIVERSITY FACULTY

Resolution No. 2002-69

Synopsis: Approval of the following amendments to the *Rules of the University Faculty* are recommended.

WHEREAS the University Senate pursuant to rule 3335-1-09 of the Administrative Code is authorized to recommend through the President to the Board of Trustees the adoption of amendments to the *Rules of the University Faculty* as approved by the University Senate; and

WHEREAS the proposed changes in the *Rules of the University Faculty* were approved by the University Senate on January 10, 2002:

Amended Rules

3335-5-21 Secretary of the university faculty.

- (A) The secretary of the university faculty shall be a tenured member of the regular faculty, appointed by the president from three nominees submitted by the executive committee of faculty council. The term of office shall be for three years. Prior service as secretary shall not preclude nomination to this office. During the term of office the secretary shall be reassigned for a minimum of fifty per cent time to the office of the faculty council during autumn, winter, spring and summer quarters. The secretary of the university faculty will be evaluated annually by the executive vice president and provost, the chair of the senate steering committee, and the chair of the faculty council.
- (B) The responsibilities of the secretary of the university faculty shall be to:
- (1) ~~Keep the records of the meetings~~ Serve as an advocate of the collective interests of the university faculty and shall furnish to the president for report to the board of trustees all matters passed by the university faculty requiring approval or action on issues of campus-wide importance. In this capacity the secretary shall:
- (a) Serve as a representative of the faculty at the faculty cabinet of the faculty council.
- (b) Serve as a non-voting member of the senate.
- (c) Serve as a non-voting member of faculty council.

AMENDMENTS TO THE RULES OF THE UNIVERSITY FACULTY (*contd*)

Amended Rules (contd)

- (d) Work to increase faculty awareness of and participation in the university senate and other university-wide governance bodies.
 - (e) Keep the records of the meetings of the university faculty and furnish to the president for report to the board of trustees all matters passed by the university faculty requiring approval or action.
 - (f) The secretary of the faculty shall report annually to the faculty council and the university senate.
- (2) Counsel and advise members of the faculty seeking information and clarification of university-wide policies that affect faculty, e.g., promotion and tenure, academic freedom, sexual harassment, paid external consulting, conflict of interest, workplace violence, and scholarly misconduct.
- (3) ~~Refer faculty to appropriate senate committees or dispute resolution mechanisms when issues such as complaints over promotion and tenure, or alleged infringement of academic freedom arise.~~ The secretary of the faculty will not, however, serve as a mediator for individual faculty member complaints.
- (a) Refer faculty to appropriate senate committees, offices, or dispute resolution mechanisms.
- (4) ~~Serve as an advocate of the collective interests of the university faculty on issues of campus-wide importance.~~
- (5) ~~Serve as a member of the faculty cabinet of the faculty council.~~
- (6) (b) Consult regularly with the office of academic affairs and the committee on academic freedom and responsibility and advise the office of academic affairs and the committee on academic freedom and responsibility on the adequacy of and needed improvements in the dispute resolution mechanisms available to faculty.
- (7) ~~Work to increase the faculty awareness of and participation in the university senate and other university-wide governance bodies. (B/T 4/7/2000, B/T 2/1/2002)~~

3335-5-452 Secretary of the university senate.

- (A) The secretary of the university senate shall be a tenured member of the regular faculty, appointed by the president from three nominees submitted by the steering committee. The term of office shall be for three years. Prior service as secretary need not preclude nomination to this office. During the term of office the secretary shall be reassigned for a minimum of fifty per cent of time to the office of the university senate during autumn, winter, spring, and summer quarters. The secretary of the senate will be evaluated annually by the executive vice president and provost, the chair of the senate steering committee, and the chair of faculty council.

(Balance unchanged)

NOW THEREFORE

AMENDMENTS TO THE RULES OF THE UNIVERSITY FACULTY (contd)

BE IT RESOLVED, That the foregoing amendments to the *Rules of the University Faculty* be adopted as recommended by the University Senate.

AMENDMENTS TO THE OHIO STATE UNIVERSITY AIRPORT RULES

Resolution No. 2002-70

Synopsis: Approval of the following amendments to rules governing the operation and use of the University Airport is recommended.

WHEREAS The Ohio State University owns and operates an airport facility to further enhance the nationally renowned teaching, research, and service missions of the Department of Aeronautical Engineering and Aviation; and

WHEREAS the University Airport has served owners of small aircraft in general aviation for several decades; and

WHEREAS the College of Engineering and the Department of Aeronautical Engineering and Aviation have revised The Ohio State University Airport Rules to reflect to the users of the facility and to the surrounding community their commitment to the missions of the University, the college, and the department; and

WHEREAS revision of these policies and their codification as Rules of the Administrative Code are deemed necessary to ensure the safety of airport operations, regulate the use of airport facilities, and generally promote the efficient operation of the airport:

Amended Rules

3335-105-01 Definitions.

As used in rules 3335-105-01 to 3335-105-11 of the Administrative Code:

(A) and (B) unchanged.

(C) "Airport manager" means that person appointed by the Ohio state university to operate and/or manage the Ohio state university airport or a designated representative. The airport director serves as the manager of the Ohio state university airport.

(D) Unchanged.

(E) "Based aircraft" means any aircraft regularly stored at the airport, either in a hangar or tied down, for which the required application to base private aircraft, including evidence of insurance and maintenance information, having been made available for inspection, has been submitted by the aircraft owner and approved by the airport manager.

(F) and (G) unchanged.

(H) "FAA ATCT" means the federal aviation administration or contracted air traffic control tower at the Ohio state university airport.

(I) Unchanged.

(J) With the exception of standard aircraft preflight inspection of aircraft fuel, "Fuel handling" means the transporting, delivering, fueling and draining of fuel or fuel waste products.

AMENDMENTS TO THE OHIO STATE UNIVERSITY AIRPORT RULES (contd)

Amended Rules (contd)

- (K) Unchanged.
- (L) "Fuel storage area" means those portions of the airport designated temporarily or permanently by the airport manager as areas in which gasoline or any other type of fuel may be stored, including but not limited to gasoline underground or above ground fuel storage locations.
- (M) Unchanged.
- (N) "Flight instructor" means a federal aviation administration certified flight instructor or ground instructor possessing a valid instructor certificate ~~hired as a member of the university's flight training clinic or otherwise approved by the airport manager.~~
- (O) through (S) unchanged.
- (T) "Public" means the people as a whole, or the community at large, ~~or~~ open to all persons or the general populace.
- (U) "Ramp and Apron Area" means those portions of the Airport designated and made available temporarily or permanently to authorized persons for loading or unloading of both passengers and cargo ~~in~~ into and from aircraft.
- (V) through (X) unchanged. (B/T 3/5/82, B/T 2/1/2002)

3335-105-02 General.

- (A) These rules shall be available for inspection at in the ~~operations desk of the airport administration office.~~
- (B) All persons using, or working at, the airport shall comply with these rules and all other rules, regulations and policies of the Ohio state university.
- (C) Based aircraft at the ~~university~~ airport shall not be operated for hire to the public from the airport for flight instruction, charter, rental, or cargo purposes without the approval of the airport manager and, as appropriate, other university officials.
- (D) and (E) unchanged.
- (F) ~~Regular employees of the university are eligible for faculty/staff rates for storage of aircraft at the airport. The faculty or staff member must be the FAA registered owner of the aircraft, or the principal officer of a corporation, principal owner of an aircraft in conjunction with a partnership, association, or other organization which owns a principal interest in the aircraft. The employee must submit a written request to the airport manager for faculty/staff rates with his or her application to base private aircraft. All persons desiring hangar space at the airport shall provide proof of ownership or lease of the aircraft to be stored, if requested by the airport manager.~~
- (G) All persons, including flying clubs, are limited to leasing no more than two t-hangar units at any one time, unless approved by the airport manager.
- ~~(G)~~(H) Rental charges for tiedown or hangar ~~space~~ shall be billed in advance and due upon receipt.
- ~~(H)~~(I) When a based aircraft is to be removed from the airport, written notice shall be furnished to the airport manager in advance of the removal. ~~In the case of hangared aircraft, a~~ A thirty-day notice in advance of such action is required. In all cases, rental charges shall

AMENDMENTS TO THE OHIO STATE UNIVERSITY AIRPORT RULES (contd)

Amended Rules (contd)

continue to and include the last day of the month designated for removal in the written notice. No refunds shall be made for unused portions of any period. Rates are subject to change without notice.

~~(H)~~(J) All debts or charges incurred at the airport are due immediately unless the airport manager approves the establishment of an account. Monthly invoices for sales and services shall be payable upon receipt. Failure to make prompt payment may result in cancellation of the based aircraft agreement or of cancellation of any leases, revocation of tiedown privileges, ~~impounding of aircraft~~, or any other action deemed appropriate by the airport manager. In addition, unpaid accounts shall be assessed late charges computed by a single periodic rate.

~~(J)~~(K) Unchanged.

~~(K)~~(L) Unchanged.

~~(L)~~(M) Unchanged.

~~(M)~~(N) Unchanged.

~~(N)~~(O) Unchanged.

~~(O)~~(P) All mechanics who are to work on aircraft at the airport shall be ~~appropriately qualified and certified by the federal aviation administration and shall be~~ registered with the airport manager.

~~(P)~~(Q) Unchanged.

~~(Q)~~(R) Owners of aircraft stored in hangars owned and operated by the university, who employ licensed and qualified mechanics for the express purpose of maintaining their specific aircraft shall maintain in force at all times, liability insurance as specified in the hangar lease to cover the total loss of, or damage to, the entire hangar structure in which their aircraft is normally stored, to include any or all aircraft, equipment, supplies or furnishings normally housed in that hangar, and death of, or injury to, any person or persons who may be in or near the hangar. Evidence of insurance, in the form of a certificate of insurance, shall be furnished to the office of the airport manager. The certificate shall indicate that the policy contains a provision that the airport manager shall be notified in writing thirty days in advance of any change or cancellation of the coverage provided.

It is the aircraft owner's responsibility to see that evidence of insurance coverage is furnished at each subsequent policy renewal or issuance or following a change of aircraft, addition of an aircraft, or any occurrence that affects the coverage involved.

~~The limits of coverage necessary for any given hangar may be adjusted periodically as the value of the aircraft stored in the hangar fluctuates or improvements or alterations to the hangar are made.~~

~~(R)~~(S) Aircraft not covered by insurance as specified in paragraph ~~(Q)~~(R) of this rule shall not be hangared, for purposes of maintenance, in hangars owned or operated by the university except in cases where such maintenance will be performed in a designated area with the approval of the airport manager and under the supervision of university aircraft maintenance personnel.

~~(S)~~(T) Special Only special or emergency maintenance may be performed on airport ramps or aprons, runways or taxiways or adjoining areas ~~only with the approval of the airport manager.~~

AMENDMENTS TO THE OHIO STATE UNIVERSITY AIRPORT RULES (contd)

Amended Rules (contd)

~~(T)~~(U) All hangars and offices at the airport shall be secured (closed and locked) at the conclusion of the business day, ~~as defined by the airport manager. Except for arriving or departing flight crews and passengers or approved mechanics performing aircraft maintenance, no person is authorized in any hangar or office after business hours without the approval of the airport manager.~~

~~(U)~~(V) Alcoholic beverages are not permitted on the airport premises, except as cargo or as provision for flight passengers, without the approval of the airport manager.

~~(V)~~(W) In the case of an apparent violation of rules 3335-105-01 to 3335-105-11 of the Administrative Code the airport manager shall have the authority to take whatever action determined ~~by him~~ to be appropriate in order to enforce these rules, including, but not limited to, cancellation of leases, revocation of based aircraft agreement, impounding of ~~aircraft,~~ vehicles or other personal property, suspension, or prohibition from the airport, or eviction of any club or member thereof. Except when deemed necessary in the interest of safety or other exceptional circumstances, the airport manager shall take such action after notifying the affected person orally or in writing of a violation of these rules and giving the affected person an opportunity to respond.

~~(W)~~(X) Any action taken by the airport manager in accordance with paragraph ~~(V)~~(W) of this rule may be appealed by the affected person to the ~~chairman~~ chairperson of the department of aerospace engineering and aviation, if appropriate, the dean of the college of engineering, and the office of academic affairs according to procedures adopted by the college of engineering.

~~(X)~~(Y) Unchanged.

~~(Y)~~(Z) Unchanged. (B/T 3/5/82, B/T 2/1/2002)

3335-105-03 Aircraft and flight operations.

(A) Unchanged.

~~(B)~~ All aircraft operated from the airport must be in airworthy condition.

~~(C)~~ It is the responsibility of the aircraft owner to operate and maintain his or her aircraft according to the federal aviation regulations and manufacturers recommendations.

~~(D)~~ All persons operating aircraft based at the airport shall hold at least a valid student pilot certificate, unless special authorization is granted by the airport manager.

~~(E)~~(B) All flight instructors conducting flight instruction ~~conducted~~ from the airport shall be provided by instructors employed by the university unless approval is granted by registered with the office of the airport manager.

~~(F)~~(C) Unchanged.

~~(G)~~(D) Aircraft based at the university airport shall be insured ~~to at least the following minimum levels under a policy of comprehensive or aircraft liability insurance coverage (which must include aviation premises coverage and coverage for indemnification)~~ in an amount:

- (1) ~~Bodily injury liability:~~ For piston engine aircraft, not less than \$1,000,000 per occurrence, and
 - ~~One hundred thousand dollars per person~~
 - ~~Five hundred thousand dollars per occurrence~~

AMENDMENTS TO THE OHIO STATE UNIVERSITY AIRPORT RULES (contd)

Amended Rules (contd)

~~Property damage liability:~~

~~Five hundred thousand dollars per occurrence, or~~

- (2) ~~Combined single limit bodily injury and property damage liability: For turbine engine aircraft, not less than \$10,000,000 per occurrence.~~
~~Seven hundred fifty thousand dollars per occurrence~~

Such insurance policy shall name the University as an additional insured with respect to liability associated with the Hangar Space, and shall be carried with companies licensed to do business in the State of Ohio reasonably satisfactory to the University, and shall be non-cancelable and not subject to material change except after thirty (30) days written notice to the Airport Manager. The insured shall deliver to the Airport Manager duly executed certificates of insurance upon request. The insured shall, upon each subsequent policy renewal or issuance, or following a change of aircraft, addition of an aircraft, or any occurrence that affects the coverage of a based aircraft, furnish to the Airport Manager, Evidence evidence of insurance coverage shall be furnished in the form of a certificate of insurance stating the name of the insured, the aircraft insured, the amounts of coverage provided and any special restrictions or considerations, and this evidence shall be delivered to the office of the airport manager. The certificate shall indicate that the policy contains the provision that the airport manager will be notified in writing thirty days in advance of any change or cancellation of the coverage provided. The Airport shall not at any time be liable for damage or injury to persons or property in or upon the Hangar Space.

~~It is the aircraft owner's responsibility to see that evidence of insurance coverage is furnished at each subsequent policy renewal or issuance, or following a change of aircraft, addition of an aircraft, or any occurrence that affects the coverage of a based aircraft.~~

- ~~(H)~~(E) The pilot in command of any aircraft involved in any incident or accident on the airport shall make a prompt and full report of the incident or accident in accordance with federal aviation regulations and report the incident or accident to the airport manager in such form as he or she may require.
- ~~(I)~~(F) Unchanged.
- ~~(J)~~(G) Only ~~university~~ airport personnel shall move aircraft in or out of hangars (except T-hangars) owned or operated by the university, unless approval has been granted by the airport manager.
- ~~(K)~~(H) Unchanged.
- ~~(L)~~(I) If an aircraft is tied down at the airport, the owners shall:
- (1) Unchanged.
 - (2) Leave a ~~written~~ request at the airport operations office for replacement of ropes that are not considered to be satisfactory for the security of the aircraft.
 - (3) unchanged.
- ~~(M)~~(J) The university, its trustees, officers, employees or agents shall not be responsible for any damage to aircraft tied down on the airport, except where the damage is the result of the negligence of airport personnel.

AMENDMENTS TO THE OHIO STATE UNIVERSITY AIRPORT RULES (contd)

Amended Rules (contd)

- (N) ~~Aircraft shall be taxied at a safe, reasonable speed for the existing conditions.~~
- (O) ~~Aircraft without functional brakes shall not be taxied near buildings or parked aircraft unless an attendant is at a wing of the aircraft.~~
- (P)(K) Unchanged.
- (Q) ~~Aircraft operating from the airport shall be equipped with a functioning radio capable of transmitting and receiving on appropriate frequencies used by the FAA ATCT, unless permission is granted by the FAA ATCT.~~
- (R)(L) Unchanged.
- (S) ~~Any flight checks by a federal aviation administration designated flight examiner shall be conducted only with the approval of the airport manager. (B/T 3/5/82, B/T 2/1/2002)~~

3335-105-04 Fuel storage and handling.

- (A) Unchanged.
- (B) ~~Only personnel engaged in fuel handling or in the maintenance and operation of the aircraft being fueled shall be permitted in the immediate vicinity of the aircraft during refueling operations.~~
- (C)(B) Unchanged.
- (D)(C) Fuel products shall not be dispensed into, transferred, or drained from, any aircraft or equipment while in any hangar on the airport, except by personnel authorized by the airport manager.
- (E)(D) Fuel products dispensed at the airport into aircraft shall be delivered by authorized personnel, vehicles, or and equipment only.
- (F)(E) Unchanged. (B/T 3/5/82, B/T 2/1/2002)

3335-105-05 Vehicles.

- (A) through (E) unchanged.
- (F) Vehicles other than airport service vehicles shall ~~not~~ be permitted in hangars owned or operated by the university ~~(except T-hangars per conditions and terms of the lease)~~ in accordance with the airport operating policies and procedures. (B/T 3/5/82, B/T 2/1/2002)

3335-105-06 Safety.

- (A) ~~Based aircraft at the airport shall be subject to inspection by the federal aviation administration at the request of the airport manager at such times as the airport manager determines that an inspection is warranted. The owner shall provide any and all ownership, maintenance and operating records pertaining to the aircraft if requested by the person(s) conducting the inspection. Discrepancies noted on such inspections shall be repaired or corrected by a federal aviation administration certified repair station and/or qualified, certified mechanic within a time period agreed upon by the owner and the airport manager.~~
- (B)(A) Unchanged.

AMENDMENTS TO THE OHIO STATE UNIVERSITY AIRPORT RULES (contd)

Amended Rules (contd)

- (C)(B) Except when they are typically a part of aircraft operations, ~~No~~ no explosives, flammable liquids, acid, toxic substances, compressed gas or any radioactive article, or other substance or material as might endanger persons or property, shall be stored, kept, handled, used, dispensed, or transported in or upon the airport without the approval of the airport manager.
- (D)(C) Unchanged.
- (E) ~~No aircraft radar equipment shall be operated or ground tested on a ramp or apron area or any area where the directional beam of high intensity radar is within three hundred feet, or the low intensity beam (less than forty KW output) is within one hundred feet of any person, another aircraft, an aircraft refueling operation, an aircraft refueling truck or aircraft fuel or flammable liquid storage facility.~~
- (F)(D) Unchanged.
- (G)(E) Unchanged.
- (H) ~~When maintenance is performed on any aircraft, two persons shall be present.~~
- (I) ~~All operations may be suspended or restricted on the airport premises by the airport manager whenever such action is deemed necessary in the interest of safety. (B/T 3/5/82, B/T 2/1/2002)~~

3335-105-07 Airport traffic procedures.

- (A) During the hours of operation of the FAA ATCT the airport traffic pattern and movement of aircraft on designated taxiways shall be directed by the FAA ATCT.
- During the hours when the FAA ATCT is not in operation standard traffic patterns procedures shall be followed as outlined in the airman's information manual and federal aviation regulations. Taxi routes to and from runways shall be as ~~shown in "Appendix A."~~ instructed by FAA ATCT.
- (B) Unchanged.
- (C) Helicopter approach and departure corridors shall be in accordance with designated routes, or as shown in "Appendix B." instructed by FAA ATCT (except police or medical emergencies). Information about current procedures concerning helicopter operations shall be available at the airport administration office. (B/T 3/5/82, B/T 2/1/2002)

3335-105-08 Environmental (noise abatement) procedures.

- (A) and (B) unchanged.
- (C) The designated corridors (~~"Appendix B"~~) for helicopter arrival and departure shall be used at all times (except police or medical emergencies). Information about current procedures concerning helicopter operations shall be available at the airport ~~operations desk and the airport manager's~~ administration office.
- (D) and (E) unchanged. (B/T 3/5/82, B/T 2/1/2002)

3335-105-09 Operating practices for flying club aircraft and members.

- (A) through (E) unchanged.

AMENDMENTS TO THE OHIO STATE UNIVERSITY AIRPORT RULES (contd)

Amended Rules (contd)

(F) Prior to operating club aircraft from the airport, a member shall:

~~(1) Be be familiar with the rules of the airport and signify that he or she has read and will abide by these rules, as well as all airport operating policies and procedures, as amended.~~

~~(2) Have a check-out in the type of aircraft to be flown by the member.~~

(G) through (H) unchanged.

(I) The airport may refuse to provide any service to a member of a flying club not listed on the membership roster filed with the airport manager. If any member of a flying club violates rules 3335-105-01 to 3335-105-11 of the Administrative Code, the airport manager shall have the authority to take action against the club or member thereof pursuant to paragraphs ~~(V)~~ (W) and ~~(W)~~ (X) of rule 3335-105-02 of the Administrative Code. (B/T 3/5/82, B/T 2/1/2002)

3335-105-10 Testing and operation of experimental and home-built aircraft.

(A) and (B) unchanged.

(C) Prior to the beginning of flight testing, the owner or pilot of an experimental, or home-built aircraft must present a copy of the airworthiness certificate and any operating limitations issued by the federal aviation administration to the airport manager ~~and~~ or the chief of facilities of the FAA ATCT.

(D) The airport manager shall be notified ~~twenty-four hours~~ in advance of the initial test flight and/or prior to each test flight until five takeoffs and landings to a full stop have been safely completed.

~~(E) All test flights, or until five takeoffs and landings to a full stop have been safely completed, shall be conducted between the hours of seven a.m. and three thirty p.m., Monday through Friday (except holidays) unless approval is granted by the airport manager.~~

~~(F) The first five takeoffs and landings to a full stop of a test aircraft shall be conducted from runway 27L. (B/T 3/5/82, B/T 2/1/2002)~~

3335-105-11 Approval for aircraft to land and/or takeoff on university property.

The landing or takeoff of all aircraft on property owned or operated by the university shall be approved in advance by the ~~director of university~~ assistant vice president for public safety with the following exceptions:

(A) through (E) unchanged.

Balance unchanged. (B/T 3/5/82, B/T 2/1/2002)

NOW THEREFORE

BE IT RESOLVED, That the foregoing amendments to *The Ohio State University Airport Rules* be adopted by the Board of Trustees.

**WAIVER OF PARAGRAPH (F) OF BYLAW 3335-1-08
OF THE ADMINISTRATIVE CODE**

Resolution No. 2002-71

Synopsis: Approval of the following Waiver of Paragraph (F) of Bylaw 3335-1-08 of Administrative Code is proposed.

WHEREAS the Board of Trustees of The Ohio State University, did on January 9, 1976, amend paragraph (F) of bylaw 3335-1-08 of the Administrative Code to state that "buildings and structures shall not be named for any person who is an officer or employee of the University or the State of Ohio, but may be named for a person who has been retired or has otherwise left such a position for a minimum of three years"; and

WHEREAS the President wishes to recommend that the Athletic Facilities Offices in Ohio Stadium be named in honor of J. Michael Dolan, who served as Assistant Athletic Director for Facilities Operations and is retiring from Ohio State University after thirty-three years of service:

NOW THEREFORE

BE IT RESOLVED, That the applicable requirements of paragraph (F) of bylaw 3335-1-08 of the Administrative Code be waived so that the athletic facilities offices located in Ohio Stadium may be named for an officer or employee of the University or the State of Ohio who has not been retired from such position for three years.

NAMING OF OFFICES

Resolution No. 2002-72

Synopsis: Naming of the athletic facilities offices located in Ohio Stadium is proposed.

WHEREAS the athletic facilities of Ohio State University host millions of campus visitors each year; and

WHEREAS J. Michael Dolan has demonstrated unwavering determination and expertise toward making the athletic facilities at Ohio State University second to none; and

WHEREAS he has played a key role in the construction of the Bill Davis Stadium, the Jerome Schottenstein Center, the Woody Hayes Athletic Center, and French Field House; and

WHEREAS his tireless efforts during the three-year renovation of Ohio Stadium resulted in a magnificent restoration of one of Ohio State's treasured campus landmarks; and

WHEREAS after 33 years of outstanding and meritorious work at The Ohio State University, J. Michael Dolan is retiring from his position of assistant athletic director for facilities:

NOW THEREFORE

BE IT RESOLVED, That in accordance with paragraph (F) of rule 3335-1-08 of the Administrative Code, the aforementioned office suite in Ohio Stadium be named the "J. Michael Dolan Athletics Facilities Offices," in his honor.

NAMING OF BUILDINGS

Resolution No. 2002-73

Synopsis: Naming of the three Alumnae Scholarship Houses currently located at 211 W. 11th Avenue, 225 W. 10th Avenue, and 231 W. 10th Avenue is proposed.

WHEAREAS the Alumnae Scholarship Housing program was initiated at The Ohio State University in 1935 by the Alumnae Council to establish cooperative housing for academically gifted women students with financial need; and

WHEAREAS the first such house was created through the generosity of Mary Pomerene in 1945; and

WHEAREAS the second such house was purchased through the generosity of Mrs. Hanley in 1954; and

WHEAREAS for over 30 years the work of the Alumnae Council was coordinated by Ruth Fechko (B.S. '47) who kept alive the tradition of Alumnae Scholarship housing and managed the daily affairs of the houses:

NOW THEREFORE

BE IT RESOLVED, That in accordance with paragraph (F) of the rule 3335-1-08 of the Administrative Code, the buildings located at: 211 W. 11th Avenue be named "Fechko Alumnae Scholarship House," 225 W. 10th Avenue be named "Hanley Alumnae Scholarship House," and 231 W. 10th Avenue be named "Pomerene Alumnae Scholarship House" in honor of the three women who have been most responsible for the long success of this program at The Ohio State University.

HONORARY DEGREES

Resolution No. 2002-74

Synopsis: The awarding of honorary degrees is recommended for approval.

WHEREAS the Committee on Honorary Degrees and the University Senate, pursuant to rule 3335-5-488 of the Administrative Code, have approved for recommendation to the Board of Trustees awarding of honorary degrees as listed below:

Charles A. Ballard	Doctor of Public Service
Eva Klein	Doctor of Science
Yuan T. Lee	Doctor of Science
Walter E. Massey	Doctor of Science
F. Sherwood Rowland	Doctor of Science
M. S. Swaminathan	Doctor of Agricultural Science
Marta Tienda	Doctor of Social Science

and

HONORARY DEGREES (contd)

WHEREAS pursuant to paragraph (B)(4) of rule 3335-1-03 of the Administrative Code, the President, after consultation with the Steering Committee of the University Senate, recommended to the Board of Trustees awarding of an honorary degree as listed below:

George M. Steinbrenner III

Doctor of Business
Administration

NOW THEREFORE

BE IT RESOLVED, That the above honorary degrees be awarded in accordance with the recommendation at a time convenient to the University and the recipients.

PERSONNEL ACTIONS

Resolution No. 2002-75

BE IT RESOLVED, That the personnel actions as recorded in the Personnel Budget Records of the University since the December 6, 2001 meeting of the Board, including the following Appointments/Reappointment, Appointment/Reappointment of Chairpersons, Reappointment of Principal Administrative Official, Professional Improvement Leaves, and Emeritus Titles, as detailed in the University Budget be approved; and

BE IT FURTHER RESOLVED, That the Medical Staff Appointments (The Arthur G. James Cancer Hospital and Richard J. Solove Research Institute) approved January 15, 2002, by The James Cancer Hospital Board, be ratified.

Appointments

- Name: MONIKA ARING
Title: Director
Center: Education and Training for Employment
Effective: January 1, 2002
Present Position: Director, Center for Workforce Development, Education Development Center, Newton, Massachusetts
- Name: E. CHRISTOPHER ELLISON
Title: Associate Vice President for Health Sciences Clinical Affairs and Vice Dean for Clinical Affairs
Office/College: Health Sciences/Medicine and Public Health
Effective: February 1, 2002
Concurrent Appointments: Chair, Department of Surgery, Associate Dean for Surgical Services, and Professor (The Robert M. Zollinger Chair of Surgery)
- Name: WOLFGANG SADEE
Titles: Professor (The Dr. Samuel T. and Lois Felts Mercer Professorship of Medicine and Pharmacology) and Director of the Pharmacogenomics Program
Department: Pharmacology
Term: April 1, 2002, through March 31, 2006
Present Position: Professor of Biopharmaceutical Sciences and Pharmaceutical Chemistry, University of California, San Francisco, School of Pharmacy

PERSONNEL ACTIONS (contd)

Reappointment

Name: GLENN S. DAEHN
Title: Professor (The Dr. Mars G. Fontana Professorship in Metallurgical Engineering)
College: Engineering
Term: October 1, 2001, through June 30, 2002

Reappointment of Principal Administrative Official

SHERRI M. GELDIN, Executive Director, Wexner Center for the Arts, effective January 1, 2002, through June 30, 2005.

Appointment of Chairpersons

January 1, 2002 through December 31, 2002

Orthopaedics Christopher C. Kaeding*

April 1, 2002 through March 31, 2006

Pharmacology Wolfgang Sadee

October 1, 2002 through June 30, 2006

English Valerie B. Lee

Reappointment of Chairperson

January 1, 2002 through December 31, 2002

Veterinary Biosciences Charles C. Capen

*Interim

Professional Improvement Leave

WILLIAM I. AUSICH, Professor, Department of Geological Sciences, effective Autumn Quarter 2002, Winter Quarter and Spring Quarter 2003.

Professional Improvement Leave – Change in Dates

THOMAS P. KASULIS, Professor, Department of Comparative Studies, change leave from Autumn Quarter 2000, Winter Quarter and Spring Quarter 2001, to Autumn Quarter 2003, Winter Quarter and Spring Quarter 2004.

Emeritus Titles

JOHN C. BURNHAM, Department of History, with the title Professor Emeritus, effective July 1, 2002.

BILLY M. CULBERTSON, College of Dentistry (Restorative/Prosthetic), with the title Professor Emeritus, effective February 1, 2002.

DONALD T. GORDON, Department of Plant Pathology, with the title Professor Emeritus, effective February 1, 2002.

PERSONNEL ACTIONS (contd)

Emeritus Titles (contd)

JOHN E. HORTON, College of Dentistry (Periodontology), with the title Professor Emeritus, effective February 1, 2002.

LOWELL R. NAULT, Department of Entomology, with the title Professor Emeritus, effective February 1, 2002.

RALF G. RAHWAN, College of Pharmacy, with the title Professor Emeritus, effective February 1, 2002.

CHARLES W. SOLT, College of Dentistry (Periodontology), with the title Professor Emeritus, effective February 1, 2002.

PHILIP A. HEATH, School of Teaching and Learning (Lima Campus), with the title Associate Professor Emeritus, effective February 1, 2002.

E. LINDA FERRIS, Ohio State University Extension, with the title Assistant Professor Emeritus, effective February 1, 2002.

ALMA M. SADDAM, Department of Human Nutrition and Food Management, with the title Assistant Professor Emeritus, effective February 1, 2002.

Medical Staff Appointments (The Arthur G. James Cancer Hospital and Richard J. Solove Research Institute)

December 2001/January 2002

Initial Appointments – Faculty

Arthur P. Bertolino, M.D., Ph.D., Internal Medicine, Dermatology, Professor, Associate Attending
Nitin Y. Bhatt, M.D., Internal Medicine, Pulmonary and Critical Care, Clinical Instructor, Associate Attending

Sherman A. Katz, M.D., Surgery, Thoracic and Cardiovascular Surgery, Assistant Professor – Clinical, Associate Attending

Richard F. Maier, Jr., D.O., Anesthesiology, Clinical Assistant Professor, Clinical Attending

Robert J. Masone, M.D., Anesthesiology, Clinical Assistant Professor - Clinical Attending

Joel L. Mayerson, M.D., Orthopaedics, Oncology, Assistant Professor, Attending

Yousef M. Mohammad, M.D., Neurology*, Assistant Clinical Professor, Associate Attending

Namita Sood, M.D., Internal Medicine, Pulmonary, Clinical Assistant Professor, Associate Attending

Thomas M. Yunger, M.D., Internal Medicine, Pulmonary and Critical Care, Clinical Instructor, Associate Attending

* contingent upon verification of unaccredited fellowship

Initial Appointments – Advanced Practice Nurses

Julia Garrett, B.S.N., M.S., C.N.P., Division of Hematology/Oncology

Marcia Starns, P.A., Division of Cardiovascular and Thoracic Surgery

Full Appointments – Faculty

Melissa Baujan, M.D., Associate Attending, Radiology

David Cohn, M.D., Attending, Obstetrics and Gynecology

Charles Eisenbeis, M.D., Ph.D., Attending, Internal Medicine, Hematology/Oncology

Magali Fernandez, M.D., Associate Attending, Neurology

PERSONNEL ACTIONS (contd)

Medical Staff Appointments (The Arthur G. James Cancer Hospital and Richard J. Solove Research Institute) (contd)

December 2001/January 2002 (contd)

Full Appointments – Faculty (contd)

Jill Foster, M.D., Associate Attending, Ophthalmology
Jon Gould, M.D., Associate Attending, Surgery
Thomas Lin, M.D., Ph.D., Attending, Hematology and Oncology

Change in Medical Staff Category

From Associate Attending to Clinical Attending:

Jill Foster, M.D., Ophthalmology
Bivik Shah, M.D., Plastic Surgery
Rafael Villalobos, D. O., Plastic Surgery

From Associate Attending to Attending:

Amit Agrawal, M.D., Otolaryngology

RESOLUTIONS IN MEMORIAM

Resolution No. 2002-76

Synopsis: Approval of Resolutions in Memoriam is proposed.

RESOLVED, That the Board adopt the following Resolutions in Memoriam and that the President be requested to convey a copy to the families of the deceased.

Wesley D. Anderson

The Board of Trustees of The Ohio State University expresses its sorrow upon the death on October 2, 2001, of Dr. Wesley D. Anderson, Professor Emeritus in the Department of Veterinary Biosciences.

Dr. Anderson was born in Hibbing, Minnesota. He received a Bachelor of Science degree with distinction in 1949, the Doctor of Veterinary Medicine degree in 1951, and the Ph.D. degree in anatomy in 1969, all from the University of Minnesota.

Professor Anderson served his country during World War II as a member of the Army (1943-1946). He had been an avid private pilot since 1953, frequently enjoying predawn excursions above the clouds to relax before beginning his day at the office.

Professor Anderson was a member of the OSU faculty for 17 years, arriving as professor and chairman of the Department of Veterinary Anatomy (1977-1986), professor of anatomy (1986 until his retirement in 1994), and professor emeritus of veterinary anatomy – a title held until his death. Prior to joining the OSU faculty, Dr. Anderson was professor and head of the Department of Veterinary Anatomy, College of Veterinary Medicine, University of Saskatchewan (1973-1977); assistant and associate professor of anatomy, Department of Anatomy, Medical School, University of Minnesota (1970-1972); assistant professor of anatomy, Departments of Anatomy and Physical Medicine and Rehabilitation, University of Minnesota (1968-1970); visiting assistant professor, Department of Anatomy, College of Veterinary Medicine, Michigan State University

RESOLUTIONS IN MEMORIAM (contd)

Wesley D. Anderson (contd)

(1967); and instructor, College of Veterinary Medicine, University of Minnesota (1964-1967). Dr. Anderson was a general practitioner in Rosemount, Minnesota (1954-1964).

During his academic career, Professor Anderson received a number of honors, including the Distinguished Teaching Award of the Minnesota Medical Foundation (1972), Professor of the Year in Pre-Clinical Sciences from the Western College of Veterinary Medicine at the University of Saskatchewan (1974), Citation of Merit from the Minnesota Veterinary Medical Alumni Association for services as president (1964-1965), and the Citation of Merit in Research from the A. Stange Company (Chicago, 1954).

Professor Anderson also served as the president of the American Association of Veterinary Anatomists (1983-1984), president of the Canadian Association of Veterinary Anatomists (1976-1977) and executive board member (1976-1978), and vice president of the World Association of Veterinary Anatomists (1979-1983). He was also a longstanding member of the American Association of Veterinary Anatomists, American Association of Anatomists, American Veterinary Medical Association, and the Pan American Association of Anatomists.

Professor Anderson believed in life-long learning and was instrumental in the development of the curriculum and teaching laboratories for study of veterinary histology and gross anatomy at The Ohio State University College of Veterinary Medicine. Dr. Anderson's lifelong dedication to the study of veterinary anatomy is exemplified by his collection of 1,500 illustrations published as the *Atlas of Canine Anatomy*, intended as an illustrated learning resource for students, practitioners, and anatomy educators.

Dr. Anderson's faculty colleagues remember his regular and important scientific contributions to the professional specialties of veterinary anatomy and the study of the microvascular system. His groundbreaking research focused on the morphology of microvascular casting of numerous mammalian species. His studies on the microvasculature of the Black Bear, *Ursus americanus*, provided valuable morphologic insight into vascular structure and function of the heart, brain, and kidneys in a species that has a cardiac rate and body temperature similar to human beings but is capable of entering a dormant state without deleterious effects. During his academic career, Professor Anderson served as major advisor for seven Ph.D. and one master's degree recipients as well as co-advisor of an additional three Ph. D. and seven master's degree recipients.

On behalf of the University community, the Board of Trustees expresses to the family of Professor Wesley D. Anderson its deepest sympathy and sense of understanding of their loss. It was directed that this resolution be inscribed upon the minutes of the Board of Trustees and that a copy be tendered to his family as an expression of the Board's heartfelt sympathy.

J. Osborn Fuller

The Board of Trustees of The Ohio State University expresses its sorrow upon the death on October 26, 2001, of Dr. J. Osborn "Oz" Fuller, Professor Emeritus in the Department of Geological Sciences.

Professor Fuller received his Bachelor of Arts degree (with honors) in geology from Lehigh University in 1934 and his doctorate from Columbia University in 1941. Prior to attaining the doctorate, he taught for two years at Mount Union College and, after receipt of the Ph.D., he served as an instructor in geology at The Ohio State University (1941-1943) and assistant professor at West Virginia University (1943-1944 and 1945-1946). In 1946, he returned to The Ohio State University as an associate professor of geology. In 1948, Dr. Fuller was appointed a professor of geology and from 1951-1967 he served as acting dean, associate dean, and dean of the College of Arts and Sciences, with administrative responsibility for some 31 academic departments.

RESOLUTIONS IN MEMORIAM (contd)

J. Osborn Fuller (contd)

Following dismemberment of the Arts College in 1967, Dr. Fuller accepted the presidency of Fairleigh-Dickinson University in New Jersey, and served in that capacity through 1973, when he resigned and returned to The Ohio State University as special assistant to the president and director of Part-time and Evening Programs. In the 1975-76 academic year, Dr. Fuller was acting dean of the College of the Arts and in 1976 he returned as a professor to the Department of Geological Sciences, where he served in various roles until his retirement in 1983.

Professor Fuller, a dedicated teacher, was involved throughout his career in the development, evaluation, and support of instruction, primarily in programs for students in beginning or elementary courses. On his return to The Ohio State University in 1946, his principal assignment was supervision of elementary course work in geology and he returned to this important work in the seven years of his pre-retirement service to the Department of Geological Sciences. In addition, however, Professor Fuller was also involved academically in the study of Ohio's non-metallic rock and mineral resources; he taught courses in this area and directed the research of numerous advanced students. He was author of four books and 23 articles on geologic subjects.

Although much of his life was devoted to college and university administration, early in his career, Professor Fuller was an active field geologist in the western United States and Newfoundland, and worked as a field assistant and assistant geologist with the U.S. Geological Survey and the Ohio Division of Geological Survey. Prior to undertaking administrative duties, he was also an active consultant in fields involving oil, gas, and industrial minerals. As an administrator, Professor Fuller served in 1959 as president of the Arts College Deans Section, of the Land-Grant College Association and, from 1959-1966 as chairman of the Liberal Arts Deans of the Big Eleven, and an associate of the Committee on Institutional Cooperation (CIC). He was also a member of the Board of Directors, Council of Colleges of Arts and Sciences in State Universities and Land-Grant Colleges; a member of the Fairleigh-Dickinson University Board of Trustees; the New Jersey Arts Council; Board of Directors of the Association of Independent Colleges and Universities; and the National Sea Grant Advisory Panel. From 1983 to the time of his death, Professor Fuller was a trustee of the Wilds International Center for Animal Preservation.

During the several periods of his tenure at The Ohio State University, Professor Fuller was a member of virtually every standing departmental, college, and university committee. Upon his return to Ohio State in 1974, he served on the University Senate and chaired the President's Committee on Admission Policies in the Professional Colleges. In the Department of Geological Sciences, he chaired the Directions for Staffing Committee and the Committee on the Self Study. He was a member Phi Beta Kappa, Sigma Xi, the American Association of Petroleum Geologists, and the National Association of Geology Teachers. He was a fellow of the American Association for the Advancement of Science, the Geological Society of America, and the Ohio Academy of Science.

On behalf of the University community, the Board of Trustees expresses to the family of Professor J. Osborn Fuller its deepest sympathy and sense of understanding of their loss. It was directed that this resolution be inscribed upon the minutes of the Board of Trustees and that a copy be tendered to his family as an expression of the Board's heartfelt sympathy.

Jean D. Hansford

The Board of Trustees of The Ohio State University expresses its sorrow upon the death on January 10, 2002, of Jean D. Hansford, Senior Campus Planner in the Office of Facilities Planning and Development.

Jean Hansford was born in Wilmington, Ohio, on January 27, 1933, and received his Bachelor of Architecture degree from The Ohio State University in 1965. He held a Master of Urban Planning degree from the University of Washington.

RESOLUTIONS IN MEMORIAM (contd)

Jean D. Hansford (contd)

Mr. Hansford began his career with the University in 1967. During his employment he was instrumental in the formulation of policy with respect to master plan issues and the translation of policy to procedures for encouraging adherence to master plan goals. Working with public officials, he wrote code and policy that affected the planning, zoning, land use, traffic circulation, parking, utilities, community improvement and other related concerns of the several University campuses. He also represented the University on city planning task forces and committees, regional planning groups and ad hoc community, city and regional planning committees. His involvement with the University has shaped the campus we know today and will guide future development. He was passionate about the University and the city and they are better places as a result.

During his career, Jean Hansford was active with the Ohio Staters, Campus Campaign Council, Campus Partners, Mid Ohio Regional Planning Commission – Transportation Advisory Committee, University District Task Force, Columbus Comprehensive Plan, Campus Arts and Memorials Committee, People Mover Committee, University Airport Advisory Council, and the University District Organization. Included in his many memberships were the Ohio Staters, the Alumni Association, and the Sphinx Honorary Society.

On behalf of the University community, the Board of Trustees expresses to the family of Jean D. Hansford its deepest sympathy and sense of understanding of their loss. It was directed that this resolution be inscribed upon the minutes of the Board of Trustees and that a copy be tendered to his family as an expression of the Board's heartfelt sympathy.

Patricia M. Meyer

The Board of Trustees of The Ohio State University expresses its sorrow upon the death on October 22, 2001, of Patricia M. Meyer, Professor Emeritus in the Department of Psychology.

Professor Meyer held a Bachelor of Arts degree in psychology from Ohio Wesleyan University and a Master's degree and Doctorate of psychology from The Ohio State University. Professionally associated with the University since 1960, Professor Meyer joined the Psychology faculty as an adjunct professor in 1971, was promoted to full professor in 1976, and retired with Professor Emeritus status in 1985. Her teaching and research helped stimulate the then fledgling field of neuropsychology, focusing on recovery of function damage.

Dr. Meyer's scholarly ability was recognized early by the National Institutes of Mental Health (NIMH) and awarded her pre-doctoral and then post-doctoral research fellowships. In 1967, she was awarded the prestigious Research Career Development Award by the NIMH. Professor Meyer's research on memory after severe brain damage, in close collaboration with her husband, Donald R. Meyer, helped to establish a field of research that has led to combinations of behavioral and pharmacological interventions of value in the management of stroke victims. In addition to publishing innumerable papers in highly-respected outlets, Professor Meyer served a term as editor-in-chief for *Physiological Psychology*, the official journal of the Psychonomic Society.

Professor Meyer served her profession admirably. During her career, she served on several committees for the NIMH, American Psychological Association (APA), and other national organizations. She was a member and fellow of the APA and member of the Society for Neurosciences, the Psychonomic Society, and the Midwestern Psychological Association. In 1999, she was recognized as a distinguished graduate of Chillicothe High School. Of especial note, Professor Meyer was widely admired for the support and encouragement she extended to students.

RESOLUTIONS IN MEMORIAM (contd)

Patricia M. Meyer (contd)

On behalf of the University community, the Board of Trustees expresses to the family of Patricia M. Meyer its deepest sympathy and sense of understanding of their loss. It was directed that this resolution be inscribed upon the minutes of the Board of Trustees and that a copy be tendered to her family as an expression of the Board's heartfelt sympathy.

Richard S. Ray

The Board of Trustees of The Ohio State University expresses its sorrow upon the death on November 5, 2001, of Richard S. Ray, Professor Emeritus in the Department of Veterinary Clinical Sciences.

Dr. Ray received his D.V.M. degree from The Ohio State University. He also received his M.S. and Ph.D. degrees from the College of Veterinary Medicine, in the areas of physiology and pharmacology. He was appointed to the faculty and began teaching veterinary physiology and pharmacology in 1955. He was a chemist at heart and loved physiology. Dr. Ray also served Ohio's horse racing industry as director of Pre- and Post-Race Testing Laboratories at The Ohio State University from 1969-1981. He helped establish testing facilities at both Scioto Downs in Columbus and Northfield Park in Cleveland.

Professor Ray served industry and government as a consultant in the areas of forensic pharmacology and toxicology and metabolic diseases. He was a fellow in the American College of Veterinary Pharmacology and Therapeutics, a member of the American Association of Equine Practitioners, American Society of Veterinary Physiologists and Pharmacologists, American Chemical Society, and Association of Drug Detection Laboratories. Dr. Ray was a co-recipient of the 1970 Achievement Award of the Ohio Chapter of the U.S. Harness Writers Association.

Dr. Ray was chairman of the University Committee on Patents and Copyrights from 1972 until his retirement from the University in 1984. He also served on various committees of the Ohio State Racing Commission, National Association of Racing Commissioners, and the American Association of Equine Practitioners.

On behalf of the University community, the Board of Trustees expresses to the family of Dr. Richard S. Ray its deepest sympathy and sense of understanding of their loss. It was directed that this resolution be inscribed upon the minutes of the Board of Trustees and that a copy be tendered to his family as an expression of the Board's heartfelt sympathy.

Fred R. Taylor

The Board of Trustees of The Ohio State University expresses its sorrow upon the death on January 6, 2002, of Fred R. Taylor, Assistant Professor Emeritus in the School of Physical Activity and Educational Services and former men's basketball coach at The Ohio State University. Fred Taylor, a native of Zanesville, Ohio, was born December 3, 1924.

Mr. Taylor played both basketball (1948-50) and baseball (1947-50) at Ohio State. He was an OSU baseball All-American as a first baseman in 1950. After graduating from OSU, Fred Taylor played professional baseball for the Washington Senators for three seasons. After the 1953 season, he quit baseball to become the freshman basketball and baseball coach at The Ohio State University. From 1959-76, he served as the Ohio State head men's basketball coach.

He is the only Ohio State men's basketball coach to win a national championship. His 1960 team defeated California 72-55 on March 19, 1960, to claim Ohio State's NCAA crown. His 1961 and 1962 teams advanced to the national championship game before falling to Cincinnati both years.

RESOLUTIONS IN MEMORIAM (contd)

Fred R. Taylor (contd)

Mr. Taylor was recognized in 1986 for his basketball coaching accomplishments by being elected to the National Basketball Hall of Fame. He is one of eight former Buckeye players and coaches currently in the Hall of Fame. Three other Buckeyes elected to the Hall of Fame--Jerry Lucas (elected as a player in 1979), John Havlicek (player, 1983) and Bob Knight (coach, 1991)--played for Mr. Taylor.

Five of his teams earned NCAA Tournament berths (1960, '61, '62, '68, '71) with four of those advancing to the Final Four (1960, '61, '62, '68). The Buckeyes also made history under Mr. Taylor by winning an unmatched five-consecutive Big Ten titles (1960-64). He also is the only Ohio State coach to lead six teams to 20 or more victories.

Over his 18 seasons as the head coach, Mr. Taylor compiled an OSU record of 297 victories in 455 career games. His teams won seven Big Ten titles, four outright, and compiled a 158-102 record in conference play. His .653 overall and .608 Big Ten winning percentages are the highest among OSU coaches with more than two years of service in Columbus.

Of Ohio State's 14 All-America selections, five played for Mr. Taylor while he was the OSU head coach. He coached All-American's Larry Siegfried (1961), John Havlicek (1962), Jerry Lucas (1962), Gary Bradds (1964), and Allan Hornyak (1973). Both Lucas (No. 11) and Bradds (No. 35) have had their numbers retired by Ohio State. Lucas was a two-time National Player of the Year (1961, '62) and Bradds won the same honor in 1964.

Seventeen of his players earned All-Big Ten honors: three forwards, five guards and nine centers. Six times, one of his players earned Academic All-Big Ten honors, including three-time winner Bill Hosket, who was an Academic All-American in 1968.

His teams won 32-consecutive games over two seasons from March 5, 1960 to March 24, 1961 and 50-consecutive home games from Dec. 1, 1959 to Dec. 2, 1963. Other streaks included 47-consecutive regular season wins, 27-consecutive Big Ten victories and 34-consecutive Big Ten wins at home.

Upon his retirement, he worked as an NBC commentator and in 1979, was an assistant coach on the U.S. basketball team that won the gold medal at the Pan American Games. From 1979-96, he was manager of The Golf Club in New Albany, Ohio.

Mr. Taylor was also an accomplished artist. The night he was hired at Ohio State, he and a few of his friends, painted an "O" in the center of the basketball floor. That the center court has had some kind of "O" ever since shows just how far his legacy extends. The Ohio State University has named a room in its current basketball facility, Schottenstein Center, after Mr. Taylor, and Fyffe Road, west of the building was renamed "Fred Taylor Drive" in his honor.

Over the years, many players have confirmed that their success in life has been directly attributed to Coach Taylor. As Bill Hosket put it, "I think his legacy is honesty and integrity and just examples of what his former players and family members can carry forward. I don't think there is anyone in college basketball who was respected more than Fred Taylor."

On behalf of the University community, the Board of Trustees expresses to the friends and colleagues of Fred R. Taylor its deepest sympathy and sense of understanding of their loss. It was directed that this resolution be inscribed upon the minutes of the Board of Trustees and that a copy be tendered to his family as an expression of the Board's heartfelt sympathy.

Walter G. Venzke

The Board of Trustees of The Ohio State University expresses its sorrow upon the death on September 18, 2001, of Dr. Walter G. Venzke, Professor Emeritus in the Department of Veterinary Biosciences.

RESOLUTIONS IN MEMORIAM (contd)

Walter G. Venzke (contd)

Dr. Venzke was born in White Lake, South Dakota, and graduated from Galva Community High School. He received the Doctor of Veterinary Medicine degree in 1935 from Iowa State University (ISU) (Ames), the Master of Science degree in genetics from the University of Wisconsin (Madison) in 1937, and the Ph.D. degree in anatomy in 1942 from Iowa State University.

He served his country during World War II as a member of the United States Army -- 1st lieutenant (1942), captain (1943), major (1943-1946), and was promoted at discharge to lieutenant colonel (1946). Walter Venzke's participation in civic organizations and service clubs included the Columbus Board of Health (1966-1982) where he was President Pro Tem (1969-1970), Sigma Xi, and the American Legion.

Professor Venzke was a member of the OSU faculty for 37 years beginning as an instructor (Zoology) in 1943, followed by successive promotions to assistant professor (1946), associate professor (1948), professor (1951), and chairman (1948) of the Department of Veterinary Medicine; professor and chairman Department of Veterinary Anatomy (1954-1977); assistant dean and secretary of the College of Veterinary Medicine (1960-1977), professor of anatomy (1977 until his retirement in 1980), and professor emeritus of Veterinary Anatomy – a title he held until his death. He served on the College of Veterinary Medicine Admissions Committee continuously from 1958 until 15 years past his official retirement and on the College Centennial Committee (1983-1985). Prior to joining the OSU faculty, Dr. Venzke worked on tuberculosis eradication for the Agricultural Research Services and as an ambulatory clinician; and was an assistant professor of Anatomy, Physiology and Pharmacology at ISU (1937-1942).

During his academic career Professor Venzke received a number of honors including election into Phi Zeta (honorary veterinary medical society) and Gamma Sigma Delta (agricultural honorary society); and was a longstanding member of the Ohio Veterinary Medical Association, American Veterinary Medical Association, American Association of Veterinary Anatomists, World Association of Veterinary Anatomists, Conference of Research Workers in Animal Diseases, and the Ohio Academy of Science. His excellence in teaching was recognized in 1969 by selection for an OSU Distinguished Teaching Award. Professor Venzke received the prestigious Gentle Doctor (Stange) Award for meritorious service in veterinary medicine from his alma mater (ISU) in 1986 and the OSU College of Veterinary Medicine Meritorious Achievement Award in 1982.

Dr. Venzke's faculty colleagues remember his regular and important scientific contributions to the professional specialties of veterinary anatomy and endocrinology. His clinically relevant research focused on morphogenesis of chicken endocrine organs; physiologic changes in the mammalian pineal gland associated with reproduction; differentiation of vaccinal and infection titers *Brucella abortus* in cattle; embryonic development of an anomaly of the ocular fundus in dogs; and effects of estrogenic steroids on blood cells. During the years he served on the OSU faculty, Professor Venzke was the major professor for 10 Ph.D. and four M.Sc. degree recipients as well as a member of the editorial board of the *American Journal of Veterinary Research*.

On behalf of the University community, the Board of Trustees expresses to the family of Professor Walter G. Venzke its deepest sympathy and sense of understanding of their loss. It was directed that this resolution be inscribed upon the minutes of the Board of Trustees and that a copy be tendered to family as an expression of the Board's heartfelt sympathy.

REPORT OF RESEARCH CONTRACTS AND GRANTS

Resolution No. 2002-77

Synopsis: The reports on research and other sponsored program contracts and grants and the summaries for November and December 2001 are presented for Board acceptance.

REPORT OF RESEARCH CONTRACTS AND GRANTS (contd)

WHEREAS monies are solicited and received on behalf of the University from governmental, industrial, and other agencies in support of research, instructional activities, and service; and

WHEREAS such monies are received through The Ohio State University Research Foundation:

NOW THEREFORE

BE IT RESOLVED, That the research agreement between The Ohio State University and The Ohio State University Research Foundation for the contracts and grants reported herein during the months of November and December 2001 be approved.

REPORT ON UNIVERSITY DEVELOPMENT

Resolution No. 2002-78

Synopsis: The report on the receipt of gifts and the summary for December 2001 are presented for Board acceptance.

WHEREAS monies are solicited and received on behalf of the University from alumni, industry, and various individuals in support of research, instructional activities, and service; and

WHEREAS such gifts are received through The Ohio State University Development Fund and The Ohio State University Foundation; and

WHEREAS this report includes the establishment of The Roy and Lois Chope Chair in Engineering, The Sanford G. Price and Isabelle P. Barbee Chair in Teaching, Advising, and Learning, The J. Gilbert Reese Chair in Contract Law, and The Dr. Samuel T. and Lois Felts Mercer Professorship of Medicine and Pharmacology; and

WHEREAS this report includes the establishment of twenty-three (23) new named endowed funds and the amendment of one (1) named endowed fund:

NOW THEREFORE

BE IT RESOLVED, That the acceptance of the report from The Ohio State University Development Fund and The Ohio State University Foundation during the month of December 2001 be approved.

REPORT ON UNIVERSITY DEVELOPMENT (contd)

TOTAL UNIVERSITY PRIVATE SUPPORT

July through December
2000 Compared to 2001

GIFT RECEIPTS BY DONOR TYPE

	Dollars July through December		
	<u>2000</u>	<u>2001</u>	<u>%Change</u>
Individuals:			
Alumni (Current Giving)	\$18,783,980	\$21,576,008	15
Alumni (From Bequests)	<u>1,358,380</u>	<u>2,356,490</u>	73
Alumni Total	\$20,142,360	\$23,932,498	19
Non-Alumni (Current Giving)	\$14,358,534	\$9,223,644	(36)
Non-Alumni (From Bequests)	<u>2,975,681</u>	<u>2,548,545</u>	(14)
Non-Alumni Total	\$17,334,215	\$11,772,189	(32)
Individual Total	\$37,476,575	\$35,704,687	(5 ^A)
Corporations/Corp/Foundations	\$20,569,002	\$22,362,755	9 ^B
Private Foundations	\$9,130,451	\$10,545,716	16 ^C
Associations and Other Organizations	<u>\$2,368,639</u>	<u>\$2,520,322</u>	6
Total	\$69,544,667	\$71,133,480	2

NOTES

- A Overall individual giving is down 5% in that gifts at the \$10,000 or more level are down 12% (\$27.4 million from 297 gifts last year compared with \$24.1 million from 289 gifts this year).
- B Corporate giving is up 9% largely due to the fact that gifts of \$10,000 or more were up 10% (336 gifts for \$16.7 million last year; 354 gifts for \$18.4 million this year).
- C Foundation giving at the \$10,000 or more level is up for the first six months of the fiscal year (\$8.5 million from 117 gifts last year; \$10.1 million from 111 gifts this year).

REPORT ON UNIVERSITY DEVELOPMENT (contd)

TOTAL UNIVERSITY PRIVATE SUPPORT (contd)

July through December
2000 Compared to 2001

GIFT RECEIPTS BY PURPOSE

	Dollars July through December		
	<u>2000</u>	<u>2001</u>	<u>% Change</u>
Gift Receipts to Current Use and Endowment Funds:			
Buildings/Equipment	\$7,157,618	\$13,332,675	86
Faculty Support	\$5,957,363	\$5,957,030	--
Program Support	\$42,749,282	\$38,526,076	(10)
Student Financial Aid	\$7,463,896	\$7,995,846	7
Annual Funds-Colleges/Departments	\$5,391,987	\$4,647,342	(13)
Annual Funds-University	<u>\$824,521</u>	<u>\$674,511</u>	(18)
Total	\$69,544,667	\$71,133,480	2

GIFT ADDITIONS TO ENDOWMENT

Dollars
July through December

<u>2000</u>	<u>2001</u>	<u>% Change</u>
\$17,909,838	\$21,404,758	20%

REPORT ON UNIVERSITY DEVELOPMENT (contd)

THE OHIO STATE UNIVERSITY DEVELOPMENT FUND

	<u>Previous Gifts</u>	<u>Current Gifts</u>	<u>Total Gifts</u>
<u>Establishment of Named Endowed Chair</u>			
The Roy and Lois Chope Chair in Engineering (Used to fund a chair in the College of Engineering; provided by a gift from the estate of Lois Chope in memory of her husband H. Roy Chope)		\$1,503,555.00	\$1,503,555.00
<u>Establishment of Named Endowed Professorship</u>			
The Dr. Samuel T. and Lois Felts Mercer Professorship of Medicine and Pharmacology (Used to support a professorship in the College of Medicine and Public Health; provided by gifts from Samuel T. Mercer in memory of his wife, Lois Felts Mercer) (Grandfathered)	\$437,038.00		\$437,038.00
<u>Establishment of Named Endowed Funds</u>			
The Willis E. "Bill" Rector Endowed Scholarship Fund in Geological Sciences (Used to provide a scholarship in the Department of Geological Sciences; provided by gifts from Jane Rector, Mr. and Mrs. Andrew Rector, Mr. and Mrs. John G. Gremmells, Mr. Linda Rector, James Wilkes, family, fellow professionals, and friends)		\$35,640.00	\$35,640.00
The Cardiac Rehabilitation P.A.C.E.R. Endowment Fund (Used to provide awards to cardiac rehabilitation patients; provided by gifts in memory of Sandra Rhodes Jacob from other cardiac patients and their family and friends)	\$25,000.00		\$25,000.00
The September 11 Memorial Fund at Fisher College (Used to support student programs; provided by funds allocated from the College's current resources and other gifts directed to the fund)		\$25,000.00	\$25,000.00

REPORT ON UNIVERSITY DEVELOPMENT (contd)

THE OHIO STATE UNIVERSITY FOUNDATION

	<u>Previous Gifts</u>	<u>Current Gifts</u>	<u>Total Gifts</u>
<u>Establishment of Named Endowed Chairs</u>			
The Sanford G. Price and Isabelle P. Barbee Chair in Teaching, Advising, and Learning (Used to support a chair in the College of Food, Agricultural, and Environmental Sciences; provided by a gift from William H. Price II in memory of his father Sanford G. Price and his aunt, Isabelle Price Barbee)		\$1,500,000.00	\$1,500,000.00
The J. Gilbert Reese Chair in Contract Law (Used to support a chair in the Moritz College of Law; provided by a gift from J. Gilbert Reese, Newark, Ohio)		\$1,500,000.00	\$1,500,000.00
<u>Establishment of Named Endowed Funds</u>			
The Richard P. and Marie R. Bremer Medical Research Fund (Used to support basic and clinical medical research; provided by gifts from the Bremer Foundation in honor of the late Richard P. and Marie R. Bremer)		\$1,000,000.00	\$1,000,000.00
The Dorothy M. Davis Heart and Lung Research Institute Endowment Fund (Used to support cardiovascular, lung, and related disease research; provided by gifts from The William H. Davis, Dorothy M. Davis and William C. Davis Foundation)		\$500,000.00	\$500,000.00
The Samuel B. Erskine Scholarship Fund (Used to fund scholarships for students in the Moritz College of Law; provided by a gift from Maxine Marquand Erskine)		\$215,745.00	\$215,745.00
The Longaberger Foundation Medical Research Fund (Used to support researchers at the Medical Center; provided by a gift from The Longaberger Foundation)		\$250,000.00	\$250,000.00
The Seth Bonder Fellowship Endowment Fund (Used to provide fellowships for graduate students in the Department of Industrial, Welding and Systems Engineering; provided by a gift from Seth Bonder)		\$250,000.00	\$250,000.00
The Archie Griffin Endowment Fund for Olympic Sports (Used to supplement scholarship costs for student athletes who are members of Olympic varsity sports teams; provided by gifts from The Archie Griffin Scholarship Fund)		\$235,212.00	\$235,212.00

REPORT ON UNIVERSITY DEVELOPMENT (contd)

THE OHIO STATE UNIVERSITY FOUNDATION (contd)

	<u>Previous Gifts</u>	<u>Current Gifts</u>	<u>Total Gifts</u>
<u>Establishment of Named Endowed Funds (contd)</u>			
The Richard P. and Marie R. Bremer Nursing Endowment Fund (Used to support research, scholarships, fellowships, or other education programs in the College of Nursing; provided by gifts from the Bremer Foundation in honor of the late Richard P. and Marie R. Bremer)		\$100,000.00	\$100,000.00
The Isabel Hatton Simmons Student Leadership and Professionalization Fund (Used to provide assistance to students in the College of Pharmacy for travel to professional meetings and field trips; provided by a gift from Isabel Hatton Simmons)		\$65,689.19	\$65,689.19
Mager Family Scholarship Fund (Used to support scholarships for undergraduates in the College of Engineering; provided by gifts from Richard D. Mager and other members of the Mager family)		\$30,000.00	\$30,000.00
The Chloe McGlinchay Heart and Cancer Research Fund (Used to support research in cancer and heart disease in the College of Medicine and Public Health; provided by a gift from the estate of Chloe McGlinchay)		\$28,968.65	\$28,968.65
The Bruce L. Lipton, M.D. Scholarship Fund in Medicine (Used to provide scholarships for medical students in the College of Medicine and Public Health; provided by gifts in memory of Bruce L. Lipton)		\$28,870.00	\$28,870.00
The Ruth Weimer Mount Fellowship Fund (Used to provide support to a graduate student in the area of student affairs/higher education; provided by gifts from family, friends, and colleagues of Ruth Weimer Mount)		\$28,201.00	\$28,201.00
The Samuel S. and Grace Hook Johnston Memorial Chemical Engineering Scholarship Fund (Used to support undergraduates pursuing bachelor degrees in the Department of Chemical Engineering; provided by a gift from the estate of Grace Hook Johnston, widow of Samuel S. Johnston)		\$28,005.00	\$28,005.00

REPORT ON UNIVERSITY DEVELOPMENT (contd)

THE OHIO STATE UNIVERSITY FOUNDATION (contd)

	<u>Previous Gifts</u>	<u>Current Gifts</u>	<u>Total Gifts</u>
<u>Establishment of Named Endowed Funds (contd)</u>			
The Ottawa County Alumni Scholarship Fund (Used to provide merit scholarships to graduates of high schools in Ottawa County, Ohio; provided by gifts from members and friends of the Ottawa County Alumni Club)		\$25,500.00	\$25,500.00
The N. L. and Barbara McCaslin Undergraduate Student Organization Support Fund (Used to help support undergraduate student organization activities in the Department of Human and Community Resource Development; provided by gifts from N.L. McCaslin, friends, family, colleagues, and students)		\$25,025.00	\$25,025.00
The Nancy E. Fitzgivens Endowed Scholarship Fund (Used to support an in-state student in the Master of Social Work program; provided by a gift from The Annie E. Casey Foundation)		\$25,000.00	\$25,000.00
Geography Faculty Fellow Fund (Used to support a two-year designation as a Geography Faculty Fellow; provided by gifts from alumni, faculty and friends of the Department of Geography)		\$25,000.00	\$25,000.00
The Richard and Margaret Hines Fund for the Promotion of Gender Equity in the Study of Medicine (Used to provide scholarships to students enrolled in the College of Medicine and Public Health; provided by gifts from an anonymous donor in honor of Richard and Margaret Hines)		\$25,000.00	\$25,000.00
The Dennis A. and Rolene Oliver Nabors, Jr., Athletic Scholarship Fund (Used to provide scholarship costs of a student athlete who is a member of the men's tennis team; provided by gifts from Dennis and Rolene Nabors)		\$25,000.00	\$25,000.00
The Evelyn E. Walter Endowment Fund (Used to provide scholarships for undergraduate and graduate students at The Ohio State University at Marion; provided by a gift from the Evelyn E. Walter Foundation)		\$25,000.00	\$25,000.00

REPORT ON UNIVERSITY DEVELOPMENT (contd)

THE OHIO STATE UNIVERSITY FOUNDATION (contd)

	<u>Previous Gifts</u>	<u>Current Gifts</u>	<u>Total Gifts</u>
<u>Change in Name of Named Endowed Fund</u>			
From: Richard and Margaret Knowlton Scholarship Fund			
To: Dick and Peggy Knowlton Scholarship Fund			
Total	\$462,038.00	\$7,500,410.70	\$7,962,448.70

THE OHIO STATE UNIVERSITY DEVELOPMENT FUND

Establishment of Named Endowed Chair

The Roy and Lois Chope Chair in Engineering

The Roy and Lois Chope Chair in Engineering was established February 1, 2002, by the Board of Trustees of The Ohio State University with a gift from the estate of Lois Chope in memory of her husband, H. Roy Chope (B.S.E.E. 1948).

All gifts are to be invested in the University's Permanent Endowment Fund, under the rules and regulations adopted by the Board of Trustees of The Ohio State University, with the right to invest and reinvest as occasion dictates.

The annual income shall be used to fund a chair in the College of Engineering. Selection will be made by the dean of the College of Engineering. Preference will be given to electrical engineering faculty due to Roy Chope's lifelong interest and professional accomplishments in this area. The Roy and Lois Chope Chair will have a term of four years. Faculty chosen for this distinguished position will be eligible for renewed appointment by the dean of the College of Engineering.

It is the desire of the donor that this fund should benefit the University in perpetuity. If the need for this fund should cease to exist or so diminish as to provide unused income, then another use shall be designated by the Board of Trustees in consultation with the appropriate administrative official who is then responsible for engineering education.

\$1,503,555.00

Establishment of Named Endowed Professorship

The Dr. Samuel T. and Lois Felts Mercer
Professorship of Medicine and Pharmacology

The Dr. Samuel T. and Lois Felts Mercer Professorship of Medicine and Pharmacology Fund was established September 1, 1993, by the Board of Trustees of The Ohio State University with gifts from Samuel T. Mercer (M.D. 1929) in memory of his beloved wife, Lois Felts Mercer. The required funding level has been reached and the professorship was established on February 1, 2002.

REPORT ON UNIVERSITY DEVELOPMENT (contd)

THE OHIO STATE UNIVERSITY DEVELOPMENT FUND (contd)

Establishment of Named Endowed Professorship (contd)

The Dr. Samuel T. and Lois Felts Mercer
Professorship of Medicine and Pharmacology (contd)

All gifts are to be invested in the University's Permanent Endowment Fund, under the rules and regulations adopted by the Board of Trustees of The Ohio State University, with the right to invest and reinvest as occasion dictates.

The annual income shall provide for a professorship of medicine and pharmacology within the College of Medicine and Public Health. Appointment to the professorship will be recommended by the senior vice president for Health Sciences and dean of the College of Medicine and Public Health.

It is the desire of the donor that this fund should benefit the University in perpetuity. If the need for this fund should cease to exist or so diminish as to provide unused income, then another use shall be designated by the Board of Trustees in consultation with the senior vice president for Health Sciences and dean of the College of Medicine and Public Health or program administrative officer in order to carry out the desire of the donor.

\$437,038.00 (Grandfathered)

Establishment of Named Endowed Funds

The Willis E. "Bill" Rector Endowed Scholarship Fund in Geological Sciences

The Willis E. "Bill" Rector Endowed Scholarship Fund in Geological Sciences was established February 1, 2002, by the Board of Trustees of The Ohio State University with gifts from Jane Rector (B.S., Occupational Therapy, 1957) of Azle, Texas; Mr. and Mrs. Andrew Rector of Azle, Texas; Mr. and Mrs. John G. Gremmels of Fort Worth, Texas; Ms. Linda Rector (M.S. 1986) of Houston, Texas; James Wilkes of Fort Worth, Texas; and additional family members, fellow professionals, and friends.

All gifts are to be invested in the University's Permanent Endowment Fund, under the rules and regulations adopted by the Board of Trustees of The Ohio State University, with the right to invest and reinvest as occasion dictates.

The annual income shall be used to provide a scholarship in the Department of Geological Sciences for a student exhibiting academic achievement, character, and financial need. The student will be chosen by the chairperson of the Department of Geological Sciences in consultation with the University Committee on Student Financial Aid. Any unused income will be returned to the principal of this fund.

It is the desire of the donors that this fund should benefit the University in perpetuity. If the need for this fund should cease to exist or so diminish as to provide unused income, then another use shall be designated by the Board of Trustees in consultation with the appropriate college dean, department chairperson, or program administrative officer in order to carry out the desire of the donors.

\$35,640.00

REPORT ON UNIVERSITY DEVELOPMENT (contd)

THE OHIO STATE UNIVERSITY DEVELOPMENT FUND (contd)

Establishment of Named Endowed Funds (contd)

The Cardiac Rehabilitation P.A.C.E.R. Endowment Fund

The Cardiac Rehabilitation P.A.C.E.R. Endowment Fund was established February 1, 2002, by the Board of Trustees of The Ohio State University with gifts made in memory of the late Sandra Rhodes Jacob (B.S.Ed. 1967) of Columbus, Ohio; and with contributions from many other cardiac patients and their family and friends, in honor of the commitment shown by the cardiac patients in rehabilitation as well as that of the staff of the Center for Wellness and Prevention for the Cardiac Rehabilitation Program. The fund was initiated and is strongly supported by "The Ten of Hearts" patient group representing individuals who have participated in OSU's Cardiac Rehabilitation Program for ten or more years.

All gifts are to be invested in the University's Permanent Endowment Fund, under the rules and regulations adopted by the Board of Trustees of The Ohio State University, with the right to invest and reinvest as occasion dictates.

The annual income shall be used for the Cardiology Rehabilitation Program in the Center for Wellness and Prevention at The Ohio State University Medical Center for providing awards to cardiac rehabilitation patients. Eligibility for these awards shall be based on a patient's demonstrated commitment to the patient goals of the Cardiac Rehabilitation Program as well as to assist patients who are financially limited to continue benefiting from the program.

If funding permits, the annual income may also be used for other cardiology rehabilitation projects, such as for new equipment, patient education, or for other projects directly benefiting cardiology patients.

The allocation of funds and the selection of the award recipient(s) shall be made by a Cardiac Rehabilitation staff committee whose membership should include members of "The Ten of Hearts" or their staff advisor (the program's medical director); and in consultation with the vice president for Health Services.

It is the desire of the donors that this fund should benefit the University in perpetuity. If the need for this fund should cease to exist or so diminish as to provide unused income, then another use shall be designated by the Board of Trustees in consultation with the medical director of the Cardiac Rehabilitation Program and the vice president for Health Services in order to carry out the desire of the donors.

\$25,000.00

The September 11 Memorial Fund at Fisher College

The September 11 Memorial Fund at Fisher College was established February 1, 2002, in memory of Kris R. Hughes (B.S.Bus.Adm. 1995), Peter E. Mardikian (B.S.Bus.Adm. 1995), and Mary Alice Wahlstrom (B.S.Bus.Adm. 1945). Should the college learn of other alumni who died because of the tragic events on September 11, 2001, their names will be added to the endowment as well. The endowment will be set up in accordance with the guidelines approved by the Board of Trustees of The Ohio State University with funds being allocated from the college's current resources and other gifts directed to the fund.

All gifts are to be invested in the University's Permanent Endowment Fund, under the rules and regulations adopted by the Board of Trustees of The Ohio State University, with the right to invest and reinvest as occasion dictates.

REPORT ON UNIVERSITY DEVELOPMENT (contd)

THE OHIO STATE UNIVERSITY DEVELOPMENT FUND (contd)

Establishment of Named Endowed Funds (contd)

The September 11 Memorial Fund at Fisher College (contd)

The annual income shall be used by the dean of The Max M. Fisher College of Business to support student programs in accordance with the strategic plans of the college.

It is the desire of the donor that this fund should benefit the University in perpetuity. If the need for this fund should cease to exist or so diminish as to provide unused income, then another use shall be designated by the Board of Trustees as recommended by the dean of the Fisher College of Business and/or appropriate University officials in order to carry out the desire of the donor.

\$25,000.00

THE OHIO STATE UNIVERSITY FOUNDATION

Establishment of Named Endowed Chairs

The Sanford G. Price and Isabelle P. Barbee Chair in Teaching, Advising, and Learning

The Sanford G. Price and Isabelle P. Barbee Chair in Teaching, Advising, and Learning was established February 1, 2002, by the Board of Directors of The Ohio State University Foundation with a gift to The Ohio State University Foundation from William H. Price II of Cody, Wyoming. The chair is named in memory of his father, Sanford G. Price, (B.S.Agr. 1919), of Woodville, Ohio, and his aunt, Isabelle Price Barbee, (B.S.H.E. 1919), of Woodville, Ohio.

All gifts are to be invested by the Foundation, under the rules and regulations adopted by the Foundation's Board of Directors, with the right to invest and reinvest as occasion dictates.

The annual income shall be used to support the work of the chair holder, a distinguished professor who will focus on improving the quality of teaching and advising throughout the College of Food, Agricultural, and Environmental Sciences through leadership in research, teaching and advising workshops, and collaboration with other faculty involved in these programs. The chair holder will continuously and systematically study the ever-evolving nature of the undergraduate student and their learning preferences. In addition, they will determine best practices for teaching and advising, and this new knowledge will be disseminated to all college and University faculty so that there is constant improvement in learning throughout the organization. The chair holder, in addition, will provide master teacher and advisor workshops for college and University faculty to disseminate these new skills and knowledge throughout The Ohio State University, thereby building a strong team to assist in research on learning, teaching, and advising. The chair shall be appointed by and serve at the pleasure of the vice president for Agricultural Administration and University Outreach, and executive dean for Food, Agricultural, and Environmental Sciences. Fund uses shall include, but not be limited to: research, workshops for university faculty, periodic conference attendance, equipment and new technology, and faculty's innovative approaches for guiding learning.

In the event that this position should remain vacant for more than one year, then the annual income from this fund shall be used for innovative and creative activities that will strengthen and enhance the teaching, advising, and learning activities of faculty in the college to carry out the college mission in an exemplary manner, and/or reinvested in the principal as directed by the vice president for Agricultural Administration and University Outreach, and executive dean for Food, Agricultural, and Environmental Sciences or his designee.

REPORT ON UNIVERSITY DEVELOPMENT (contd)

THE OHIO STATE UNIVERSITY FOUNDATION (contd)

Establishment of Named Endowed Chairs (contd)

The Sanford G. Price and Isabelle P. Barbee Chair in Teaching, Advising, and Learning (contd)

It is the desire of the donor that this fund should benefit the University in perpetuity. If the need for this fund should cease to exist or so diminish as to provide unused income, then another use shall be designated by the vice president for Agricultural Administration and University Outreach, and executive dean for Food, Agricultural, and Environmental Sciences, in consultation with a member of the William H. Price II family, initially his daughter, Susan P. Hollern, in order to carry out the desire of the donor.

\$1,500,000.00

The J. Gilbert Reese Chair in Contract Law

The J. Gilbert Reese Chair in Contract Law in the Moritz College of Law at The Ohio State University was established February 1, 2002 in accordance with the guidelines approved by the Board of Directors of The Ohio State University Foundation with a gift from J. Gilbert Reese, (B.A. Arts & Sciences 1949, J.D. 1952), Newark, Ohio.

This gift is to be held in perpetuity and the assets thereof invested by the Foundation, under its rules and regulations with the right to invest and reinvest as determined by the Foundation.

The objective and understanding of The Ohio State University Foundation (Foundation) and J. Gilbert Reese (Donor) is to enable the Moritz College of Law at The Ohio State University to attract to the College, hire and retain a professor with a national reputation for excellence as a law school professor by using the income from the gift as an addition to University and State of Ohio funds, not in partial substitution therefor, and therefore, the annual income after normal and reasonable expenses of management of the Fund, as prescribed by the endowment distribution policy established by The Ohio State University Board of Trustees will be paid annually to the professor selected to hold the Reese Chair in Contract Law at the Moritz College of Law at The Ohio State University in addition to a full-time full law professor's salary and other perquisites paid from University and State funds. The holder of the Reese Chair in Contract Law shall be initially hired at a salary not less than a sum equal to the income produced by the Fund, plus the average salary and perquisites of those full-time full professors who do not hold professorships or chairs at the time the holder of the Reese Chair is hired. The Donor, or his daughter, Sarah Reese Wallace, as long as either shall be living, shall be advised of the identity and qualifications of candidates for the Chair before hiring of a professor to hold the Chair.

In any year or part thereof during which the Chair is not held by such a professor, the income from the Chair fund shall be added to the principal of the Chair fund. This shall continue until a suitable candidate for the position has been found and retained. The Donor retains the right and privilege, at his or members of his family's discretion, of adding monies to the Reese Chair fund from time to time.

It is the desire of the Donor, his wife and children, that this fund should benefit the Moritz College of Law of the University in perpetuity. If the need for Chairs in the Moritz College of Law should cease to exist or so diminish as to provide unused income, then another use within the Moritz College of Law shall be designated by the Foundation Board as recommended by the Dean of the Moritz College of Law after consultation with the donor, or his daughter, Sarah Reese Wallace, if either of them be living, in order to carry out the desire of the Donor.

\$1,500,000.00

REPORT ON UNIVERSITY DEVELOPMENT (contd)

THE OHIO STATE UNIVERSITY FOUNDATION (contd)

Establishment of Named Endowed Funds

The Richard P. and Marie R. Bremer Medical Research Fund

The Richard P. and Marie R. Bremer Medical Research Fund was established February 1, 2002, in accordance with the guidelines approved by the Board of Directors of The Ohio State University Foundation, with gifts from the Bremer Foundation of Youngstown, Ohio, in honor of the late Richard P. and Marie R. Bremer.

All gifts are to be invested by the Foundation, under the rules and regulations adopted by the Foundation's Board of Directors, with the right to invest and reinvest as occasion dictates.

The annual income shall be used to support medical research, both basic and clinical, with funds allocated in a competitive manner to a physician faculty member of the College of Medicine and Public Health. Applicants for the award(s) shall be reviewed by Henry G. Cramblett, M.D., dean and professor emeritus, and by the associate vice president for Health Sciences Research and vice dean for Research in the College of Medicine and Public Health. Recommendations from this review committee of the award recipient(s) shall be approved by the senior vice president for Health Sciences and dean of the College of Medicine and Public Health. Should Dr. Cramblett no longer be able or willing to serve, a successor may be named by the senior vice president for Health Sciences and dean of the College of Medicine and Public Health.

It is the desire of the donor that this fund should benefit the University in perpetuity. If the need for this fund should cease to exist or so diminish as to provide unused income, then another use shall be designated by the Foundation Board as recommended by the senior vice president for Health Sciences and dean of the College of Medicine and Public Health in consultation with the associate vice president for Health Sciences Research and vice dean for Research in the College of Medicine and Public Health in order to carry out the desire of the donor.

\$1,000,000.00

The Dorothy M. Davis Heart and Lung Research Institute Endowment Fund

The Dorothy M. Davis Heart and Lung Research Institute Endowment Fund was established February 1, 2002, in accordance with the guidelines approved by the Board of Directors of The Ohio State University Foundation, with gifts from The William H. Davis, Dorothy M. Davis, and William C. Davis Foundation at the Columbus Foundation of Columbus, Ohio.

All gifts are to be invested by the Foundation, under the rules and regulations adopted by the Foundation's Board of Directors, with the right to invest and reinvest as occasion dictates.

The annual income shall be used to support cardiovascular, lung, and related disease research in The Dorothy M. Davis Heart and Lung Research Institute (DHLRI). Income shall be distributed by the DHLRI director in consultation with the DHLRI executive committee and the senior vice president for Health Sciences and dean of the College of Medicine and Public Health. Programs supported include DHLRI sponsored international research symposia, guest lecture programs, faculty mentor awards, scientific equipment purchases, scientific core facility operation, seed grants for new investigators, and other programs of a scholarly and scientific nature.

It is the desire of the donors that this fund should benefit the University in perpetuity. If the need for this fund should cease to exist or so diminish as to provide unused income, then another use shall be designated by the Foundation Board in consultation with the appropriate college dean, department chairperson, or program administrative officer in order to carry out the desire of the donors.

\$500,000.00

REPORT ON UNIVERSITY DEVELOPMENT (contd)

THE OHIO STATE UNIVERSITY FOUNDATION (contd)

Establishment of Named Endowed Funds (contd)

The Samuel B. Erskine Scholarship Fund

The Samuel B. Erskine (J.D. 1929) Scholarship Fund was established February 1, 2002, in accordance with the guidelines approved by the Board of Directors of The Ohio State University Foundation, with a gift from Maxine Marquand Erskine, Athens, Ohio.

All gifts are to be invested by the Foundation, under the rules and regulations adopted by the Foundation's Board of Directors, with the right to invest and reinvest as occasion dictates.

The annual income shall be used to fund scholarships for law students who demonstrate financial need, preferably from Athens, Ross, or other Appalachian counties in Ohio. Recipients will be selected by the Moritz College of Law with formal approval by the dean of the College in consultation with the University Committee on Student Financial Aid.

It is the desire of the donor that this fund should benefit the University in perpetuity. If the need for this fund should cease to exist or so diminish as to provide unused income, then another use shall be designated by the Foundation Board in consultation with the appropriate college dean, school director, department chairperson, or program administrative officer in order to carry out the desire of the donor.

\$215,745.00

The Longaberger Foundation Medical Research Fund

The Longaberger Foundation Medical Research Fund was established February 1, 2002, in accordance with the guidelines approved by the Board of Directors of The Ohio State University Foundation, with a gift in honor of Dr. Manuel Tzagournis (B.S. 1956, M.D., cum laude, 1960, M.S. 1967), former vice president for Health Sciences and dean of the College of Medicine and Public Health, from The Longaberger Foundation of Newark, Ohio.

All gifts are to be invested by the Foundation, under the rules and regulations adopted by the Foundation's Board of Directors, with the right to invest and reinvest as occasion dictates.

The annual income from this fund, and other similar funds under the Manual Tzagournis M.D. Medical Research Endowment Trust, shall be used to support researchers conducting research at the Medical Center, mainly in the Manual Tzagournis Medical Research Facility, with selection made through a grant application process. Researchers may apply for one-year funding grants, which are not limited to senior faculty, through the associate vice president for Health Sciences Research and vice dean for Research in the College of Medicine and Public Health. Selection shall be made by the associate vice president for Health Sciences Research and vice dean for Research in consultation with the senior vice president for Health Sciences and dean of the College of Medicine and Public Health. The grants may be used for, but are not limited to, supplies, equipment, salaries for research personnel, and activities required for quality medical research.

It is the desire of The Longaberger Foundation that this fund should benefit the University in perpetuity. If the need for this fund should cease to exist or so diminish as to provide unused income, then another use shall be designated by the Foundation Board in consultation with the associate vice president for Health Sciences Research and vice dean for Research and the senior vice president for Health Sciences and dean of the College of Medicine and Public Health in order to carry out the desire of The Longaberger Foundation.

\$250,000.00

REPORT ON UNIVERSITY DEVELOPMENT (contd)

THE OHIO STATE UNIVERSITY FOUNDATION (contd)

Establishment of Named Endowed Funds (contd)

The Seth Bonder Fellowship Endowment Fund

The Seth Bonder Fellowship Endowment Fund was established February 1, 2002, in accordance with the guidelines approved by the Board of Directors of The Ohio State University Foundation with a gift from Seth Bonder (Ph.D. 1965).

All gifts are to be invested by the Foundation, under the rules and regulations adopted by the Foundation Board of Directors, with the right to invest and to reinvest as occasion dictates.

The annual income from this fund shall provide one or more fellowships for superior entering (first-year) graduate students who are studying and researching operations research. Each fellowship will be for 12 months (one year) and non-renewable. The fellowships will include fee authorization of payment of all tuition and fees provided by The Ohio State University. The fellows will not be required to serve as teaching assistants or as research assistants.

The chairperson of the Department of Industrial, Welding, and Systems Engineering will be responsible for administering these graduate fellowships, in consultation with Department faculty in the area of applied operations research and in cooperation with the University's Graduate School. The chairperson will use these fellowships to recruit and support excellent first-year students seeking master's or doctoral degrees in the operations research area.

The Seth Bonder Fellows shall have demonstrated an interest in operational process modeling and analysis, and shall have the potential for making significant contributions to the field of applied operations research, preferably in areas such as health, national security, energy, or other non-industrial (non-manufacturing) application areas. Each fellow will be guided by and work with faculty whose research focus is in applied operations research.

It is the desire of the donor that this fund should benefit the University in perpetuity. If the need for this fund should cease to exist or so diminish as to provide unused income, then another student-assisted related use shall be designated by the Foundation Board in consultation with the appropriate college dean, department chairperson, or program administrative officer, in order to carry out the desire of the donor.

\$250,000.00

The Archie Griffin Endowment Fund for Olympic Sports

The Archie Griffin Endowment Fund for Olympic Sports was established February 1, 2002, in accordance with the guidelines approved by the Board of Directors of The Ohio State University Foundation, with gifts from The Archie Griffin Scholarship Fund.

All gifts are to be invested by the Foundation, under the rules and regulations adopted by the Foundation's Board of Directors, with the right to invest and reinvest as occasion dictates.

The annual income shall be used to supplement scholarship costs for student athletes who are members of Olympic varsity sports teams pursuing an undergraduate degree at The Ohio State University. Recipients shall be selected by the director of Athletics in consultation with the University Committee on Student Financial Aid.

REPORT ON UNIVERSITY DEVELOPMENT (contd)

THE OHIO STATE UNIVERSITY FOUNDATION (contd)

Establishment of Named Endowed Funds (contd)

The Archie Griffin Endowment Fund for Olympic Sports (contd)

It is the desire of the donor that this fund should benefit the University in perpetuity. If the need for this fund should cease to exist or so diminish as to provide unused income, then another use shall be designated by the Foundation Board as recommended by the director of Athletics in order to carry out the desire of the donor.

\$235,212.00

The Richard P. and Marie R. Bremer Nursing Endowment Fund

The Richard P. and Marie R. Bremer Nursing Endowment Fund was established February 1, 2002, in accordance with the guidelines approved by the Board of Directors of The Ohio State University Foundation, with gifts from the Bremer Foundation of Youngstown, Ohio, in honor of the late Richard P. and Marie R. Bremer.

All gifts are to be invested by the Foundation, under the rules and regulations adopted by the Foundation's Board of Directors, with the right to invest and reinvest as occasion dictates.

The annual income shall be used to support research, scholarships, fellowships, or other education programs in Nursing as recommended by the dean of the College of Nursing in consultation with Joan L. McCoy. If used for scholarships, preference shall be given to Youngstown-area residents and selection shall be made in consultation with the University Committee on Student Financial Aid.

It is the desire of the donor that this fund should benefit the University in perpetuity. If the need for this fund should cease to exist or so diminish as to provide unused income, then another use shall be designated by the Foundation Board in consultation with the dean of the College of Nursing in order to carry out the desire of the donor.

\$100,000.00

The Isabel Hatton Simmons Student Leadership and Professionalization Fund

The Isabel Hatton Simmons Student Leadership and Professionalization Fund was established February 1, 2002, in accordance with the guidelines approved by the Board of Directors of The Ohio State University Foundation, with a gift from Isabel Hatton Simmons, (B.S. Journalism 1931), of Columbus, Ohio.

All gifts are to be invested by the Foundation, under the rules and regulations adopted by the Foundation's Board of Directors, with the right to invest and reinvest as occasion dictates.

The annual income shall be used to provide assistance for College of Pharmacy students to travel to professional meetings and participate in field trips. The fund shall also provide support for students elected to national leadership of professional organizations and speakers/lecturers/scholars in residence of interest to students.

It is the desire of the donor that this fund should benefit the University in perpetuity. If the need for this fund should cease to exist or so diminish as to provide unused income, then another use shall be designated by the Foundation Board in consultation with the dean of the College of Pharmacy in order to carry out the desire of the donor.

\$65,689.19

REPORT ON UNIVERSITY DEVELOPMENT (contd)

THE OHIO STATE UNIVERSITY FOUNDATION (contd)

Establishment of Named Endowed Funds (contd)

Mager Family Scholarship Fund

The Mager Family Scholarship Fund was established February 1, 2002, in accordance with the guidelines approved by the Board of Directors of The Ohio State University Foundation, with gifts from Richard D. Mager (B.S.I.E. 1972), Western Springs, Illinois, and other members of the Mager family.

Mr. Mager intends to fund the endowment with an initial gift of \$30,000. He reserves the right to make additional gifts to the endowment as he sees fit. All gifts are to be invested by the Foundation, under the rules and regulations adopted by the Foundation's Board of Directors, with the right to invest and reinvest as occasion dictates.

The annual income shall be used to support one or more scholarships for deserving undergraduates who are pursuing a bachelor's degree in engineering. Preference will go to graduates of any Belmont County (Ohio) high school. Recipients will be selected by the dean of the College of Engineering in consultation with the University Committee on Student Financial Aid. All unused income will be added to the principal by the end of each fiscal year.

It is the desire of the donors that this fund should benefit the University in perpetuity. If the need for this fund should cease to exist or so diminish as to provide unused income, then another use shall be designated by the Foundation Board in consultation with the donor or his heirs, and the dean of the College of Engineering in order to carry out the desire of the donors.

\$30,000.00

The Chloe McGlinchay Heart and Cancer Research Fund

The Chloe McGlinchay Heart and Cancer Research Fund was established February 1, 2002, in accordance with the guidelines approved by the Board of Directors of The Ohio State University Foundation, with a gift from the estate of Chloe McGlinchay (B.S.Ed. 1921, M.S. 1922) of Columbus, Ohio.

All gifts are to be invested by the Foundation, under the rules and regulations adopted by the Foundation's Board of Directors, with the right to invest and reinvest as occasion dictates.

The annual income shall be used to support basic and clinical research in areas of cancer and heart disease in the College of Medicine and Public Health, in The Arthur G. James Cancer Hospital and Richard J. Solove Research Institute, and in the Comprehensive Cancer Center as allocated and approved by the senior vice president for Health Sciences and dean of the College of Medicine and Public Health.

It is the desire of the donor that this fund should benefit the University in perpetuity. If the need for this fund should cease to exist or so diminish as to provide unused income, then another use shall be designated by the Foundation Board in consultation with the senior vice president for Health Sciences and dean of the College of Medicine and Public Health in order to carry out the desire of the donor.

\$28,968.65

REPORT ON UNIVERSITY DEVELOPMENT (contd)

THE OHIO STATE UNIVERSITY FOUNDATION (contd)

Establishment of Named Endowed Funds (contd)

The Bruce L. Lipton, M.D. Scholarship Fund in Medicine

The Bruce L. Lipton, M.D. Scholarship Fund in Medicine was established February 1, 2002, in accordance with the guidelines approved by the Board of Directors of The Ohio State University Foundation, with gifts in memory of Bruce L. Lipton, M.D. (B.S. 1958, M.D. 1962) of Liberty Township, Ohio.

Dr. Lipton's career and life were marked by his pursuit of excellence in medicine, his commitment to his family and to the Mahoning Valley area, and his loyalty to his alma mater, The Ohio State University. This fund was initiated by The Ohio State University Alumni Club of Mahoning County and supported by the family, classmates, colleagues, and friends of Dr. Lipton.

All gifts are to be invested by the Foundation, under the rules and regulations adopted by the Foundation's Board of Directors, with the right to invest and reinvest as occasion dictates.

The annual income shall provide one or more scholarships to first-year medical students, and may be extended to second-year students, who are enrolled in the College of Medicine and Public Health and are from Trumbull, Mahoning, or Columbiana Counties in Ohio. The selection of the recipient(s) shall be based on academic merit and financial need, and shall be approved by the senior vice president for Health Sciences and dean of the College of Medicine and Public Health upon consultation with an ad hoc committee comprised of one representative each from the OSU Alumni Club of Mahoning County, the family of Bruce L. Lipton, M.D., and the College of Medicine and Public Health Committee for Scholarship Awards. This committee shall be chaired by the president of the aforementioned alumni club and shall consult with the University Committee on Student Financial Aid and with the College of Medicine and Public Health Committee for Scholarship Awards. Any unused income shall be returned to principal for reinvestment.

It is the desire of the donors that this fund should benefit the University in perpetuity. If the need for this fund should cease to exist or so diminish as to provide unused income, then another use shall be designated by the Foundation Board in consultation with the senior vice president for Health Sciences and dean of the College of Medicine and Public Health and the ad hoc committee in order to carry out the desire of the donors.

\$28,870.00

The Ruth Weimer Mount Fellowship Fund

The Ruth Weimer Mount Fellowship Fund was established February 1, 2002, in accordance with the guidelines approved by the Board of Directors of The Ohio State University Foundation, with gifts from family, friends, and colleagues of Ruth Weimer Mount. The gifts were made specifically to recognize her role as "First Lady" of University College from 1970 to 1983 and her longstanding commitment to the people and programs of University College.

All gifts are to be invested by the Foundation, under the rules and regulations adopted by the Foundation's Board of Directors, with the right to invest and reinvest as occasion dictates.

The annual income shall provide support to a graduate student in the area of student affairs/higher education, who shall be known as the Ruth Weimer Mount Fellow and who shall be annually selected from the leading students enrolled in the doctoral program. The recipient shall already have a Student Personnel Assistantship. The income from the fellowship shall be used to support additional professional development. Selection of the fellow shall be made by the dean

REPORT ON UNIVERSITY DEVELOPMENT (contd)

THE OHIO STATE UNIVERSITY FOUNDATION (contd)

Establishment of Named Endowed Funds (contd)

The Ruth Weimer Mount Fellowship Fund (contd)

of the College of Education in consultation with the faculty in student affairs/higher education who are responsible for the Student Personnel Assistantship Program and in consultation with the University Committee on Student Financial Aid.

It is the desire of the donors that this fund should benefit the University in perpetuity. If the need for this fund should cease to exist or so diminish as to provide unused income, then another use shall be designated by the Foundation Board in consultation with the dean of the College of Education in order to carry out the desire of the donors.

\$28,201.00

The Samuel S. and Grace Hook Johnston Memorial
Chemical Engineering Scholarship Fund

The Samuel S. and Grace Hook Johnston Memorial Chemical Engineering Scholarship Fund was established February 1, 2002, in accordance with the guidelines approved by the Board of Directors of The Ohio State University Foundation, with a gift from the estate of Grace Hook Johnston, widow of Samuel S. Johnston (B.Ch.E. 1932), of Steubenville, Ohio.

All gifts are to be invested by the Foundation, under the rules and regulations adopted by the Foundation's Board of Directors, with the right to invest and reinvest as occasion dictates.

The annual income shall be used to support academically and financially deserving undergraduates who are pursuing bachelor degrees in chemical engineering. Selection will be made by the chairperson of the Department of Chemical Engineering in consultation with the University Committee on Student Financial Aid.

It is the desire of the donor that this fund should benefit the University in perpetuity. If the need for this fund should cease to exist or so diminish as to provide unused income, then another use shall be designated by the Foundation Board in consultation with the Department of Chemical Engineering and dean of the College of Engineering in order to carry out the desire of the donor.

\$28,005.00

The Ottawa County Alumni Scholarship Fund

The Ottawa County Alumni Scholarship Fund was established February 1, 2002, in accordance with the guidelines approved by the Board of Directors of The Ohio State University Foundation, with gifts from members and friends of the Ottawa County Alumni Club.

All gifts are to be invested by the Foundation, under the rules and regulations adopted by the Foundation's Board of Directors, with the right to invest and reinvest as occasion dictates.

The annual income shall be used to provide merit scholarships to graduates of high schools in Ottawa County, Ohio. The potential recipients will be recruited, interviewed, ranked by the Ottawa County Alumni Club, and recommended to the Office of Student Financial Aid. The scholarships will be awarded in consultation with the University Committee on Student Financial Aid. Any unused income will be reinvested to the principal.

REPORT ON UNIVERSITY DEVELOPMENT (contd)

THE OHIO STATE UNIVERSITY FOUNDATION (contd)

Establishment of Named Endowed Funds (contd)

The Ottawa County Alumni Scholarship Fund (contd)

It is the desire of the donors that this fund should benefit the University in perpetuity. If the need for this fund should cease to exist or so diminish as to provide unused income, then another use shall be designated by the Foundation Board in consultation with the vice president for University Development, and the director of Financial Aid in order to carry out the desire of the donors.

\$25,500.00

The N. L. and Barbara McCaslin Undergraduate Student Organization Support Fund

The N. L. and Barbara McCaslin Undergraduate Student Organization Support Fund was established February 1, 2002, in accordance with the guidelines approved by the Board of Directors of The Ohio State University Foundation, with gifts from N. L. McCaslin, former chair and professor emeritus in the Department of Human and Community Resource Development, of Columbus; and friends, family, colleagues, and students.

All gifts are to be invested by the Foundation, under the rules and regulations adopted by the Foundation's Board of Directors, with the right to invest and reinvest as occasion dictates.

The annual income shall be under the direction of the Department chair and used to help support undergraduate student organization activities in the Department of Human and Community Resource Development. These activities are to be used for organizational purposes, not individual member purposes. All student organization dues paying members are eligible for participation. Appropriate uses of the funds include travel to student conferences, participation in professional development activities, and support of student organization projects. Other uses of the fund should be approved by the chairperson in consultation with the Undergraduate Studies Committee. The chairperson and the Undergraduate Studies Committee will also oversee the use of the funds.

It is the desire of the donors that this fund should benefit the University in perpetuity. If the need for this fund should cease to exist or so diminish as to provide unused income, then another use shall be designated by the Foundation Board in consultation with the vice president for Agricultural Administration and University Outreach, and executive dean for Food, Agricultural, and Environmental Sciences, in consultation with the chairperson of the Department of Human and Community Resource Development, or their successor, in order to carry out the desire of the donors.

\$25,025.00

The Nancy E. Fitzgivens Endowed Scholarship Fund

The Nancy E. Fitzgivens Endowed Scholarship Fund was established February 1, 2002, by the Board of Directors of The Ohio State University Foundation with a gift from The Annie E. Casey Foundation, Baltimore, Maryland.

All gifts are to be invested in the Foundation, under the rules and regulations adopted by the Foundation's Board of Directors, with the right to invest and reinvest as occasion dictates.

REPORT ON UNIVERSITY DEVELOPMENT (contd)

THE OHIO STATE UNIVERSITY FOUNDATION (contd)

Establishment of Named Endowed Funds (contd)

The Nancy E. Fitzgivens Endowed Scholarship Fund (contd)

The annual income shall be used to support an in-state student of the master of social work program, with preference given to a candidate who has been working in the public child welfare system of Ohio. The scholarship will be awarded in consultation with the University Committee on Student Financial Aid.

It is the desire of the donor that this fund should benefit the University in perpetuity. If the need for this fund should cease to exist or so diminish as to provide unused income, then another use shall be determined by the Foundation Board in consultation with the dean of the College of Social Work in order to carry out the desire of the donor.

\$25,000.00

Geography Faculty Fellow Fund

The Geography Faculty Fellow Fund was established February 1, 2002, in accordance with the guidelines approved by the Board of Directors of The Ohio State University Foundation, with gifts from alumni, faculty, and friends of the Department of Geography.

All gifts are to be invested by the Foundation, under the rules and regulations adopted by the Foundation's Board of Directors, with the right to invest and reinvest as occasion dictates.

The annual income shall be used to support a two-year designation as a Geography Faculty Fellow. These proceeds are to enhance the scholarship of the fellow, but not to augment that person's salary. The department chairperson will appoint a faculty committee to solicit and review proposals from current tenure eligible members of the geography faculty at The Ohio State University. The selection of fellow(s) will be made by the department chairperson. It is anticipated that most awards will go to assistant and associate professors, that successive designations would not be made, and that expiration of a faculty fellow's term need not be immediately followed by a new appointment. The guiding consideration in the choice of fellows will be the extent to which the designation would make a significant difference in the professional development of the fellow.

At some time in the future, there may be sufficient faculty fellow endowment funds so that this fund can be converted into a named chair or professorship either by itself or in combination with other similar funds.

It is the desire of the donors that this fund should benefit the University in perpetuity. If the need for this fund should cease to exist or so diminish as to provide unused income, then another use shall be designated by the Foundation Board in consultation with the appropriate college dean, department chairperson, or program administrative officer in order to carry out the desire of the donors.

\$25,000.00

The Richard and Margaret Hines Fund
for the Promotion of Gender Equity in the Study of Medicine

The Richard and Margaret Hines Fund for the Promotion of Gender Equity in the Study of Medicine was established February 1, 2002, in accordance with the guidelines approved by the Board of Directors of The Ohio State University Foundation, with gifts from an anonymous donor in honor of Richard and Margaret Hines.

REPORT ON UNIVERSITY DEVELOPMENT (contd)

THE OHIO STATE UNIVERSITY FOUNDATION (contd)

Establishment of Named Endowed Funds (contd)

The Richard and Margaret Hines Fund
for the Promotion of Gender Equity in the Study of Medicine (contd)

All gifts are to be invested by the Foundation, under the rules and regulations adopted by the Foundation's Board of Directors, with the right to invest and reinvest as occasion dictates.

The annual income shall be used to provide one or more scholarships to students enrolled in the College of Medicine and Public Health. The purpose of the fund is to enhance the educational opportunities for first-year graduate students in anatomy or biomedical engineering or for first-year medical students; and to directly promote gender equity to the extent consistent with applicable law. The selection of the recipient(s) shall be made at the recommendation of the senior vice president for Health Sciences and dean of the College of Medicine and Public Health in consultation with the College of Medicine and Public Health Committee for Scholarship Awards and with the University Committee on Student Financial Aid.

It is the desire of the donor that this fund should benefit the University in perpetuity. If the need for this fund should cease to exist or so diminish as to provide unused income, then another use shall be designated by the Foundation Board in consultation with the senior vice president for Health Sciences and dean of the College of Medicine and Public Health in order to carry out the desire of the donor.

\$25,000.00

The Dennis A. and Rolene Oliver Nabors, Jr., Athletic Scholarship Fund

The Dennis A. and Rolene Oliver Nabors, Jr., Athletic Scholarship Fund was established February 1, 2002, in accordance with the guidelines approved by the Board of Directors of The Ohio State University Foundation, with gifts from Dennis (D.D.S. cum laude 1961) and Rolene (B.S., Physical Therapy, 1958) Nabors, Jr., of Cincinnati, Ohio.

All gifts are to be invested by the Foundation, under the rules and regulations adopted by the Foundation's Board of Directors, with the right to invest and reinvest as occasion dictates.

The annual income shall be used to provide scholarship costs of a student athlete who is a member of the men's tennis team pursuing an undergraduate degree at The Ohio State University. The recipient must maintain a 3.0 GPA. The director of Athletics, in consultation with the head tennis coach, the Student Athlete Support Services Offices, and the University Committee on Student Financial Aid, shall select the recipient.

It is the desire of the donors that this fund should benefit the University in perpetuity. If the need for this fund should cease to exist or so diminish as to provide unused income, then another use shall be designated by the Foundation Board as recommended by the director of Athletics in order to carry out the desire of the donors.

\$25,000.00

The Evelyn E. Walter Endowment Fund

The Evelyn E. Walter Endowment Fund was established February 1, 2002, in accordance with the guidelines approved by the Board of Directors of The Ohio State University Foundation, with a gift from the Evelyn E. Walter Foundation of Marion, Ohio.

REPORT ON UNIVERSITY DEVELOPMENT (contd)

THE OHIO STATE UNIVERSITY FOUNDATION (contd)

Establishment of Named Endowed Funds (contd)

The Evelyn E. Walter Endowment Fund (contd)

All gifts are to be invested by the Foundation, under the rules and regulations adopted by the Foundation's Board of Directors, with the right to invest and reinvest as occasion dictates.

The annual income shall be used to provide scholarships for undergraduate and graduate students at The Ohio State University at Marion. Preference shall be given to second-year and non-traditional students who have demonstrated need due to unique life circumstances, and who may need an additional source of financial aid. If additional criteria are necessary for the scholarship selection process, secondary preference shall be given to undergraduate students with a permanent address in Marion County, Ohio. The scholarship will be awarded in consultation with the University Committee on Student Financial Aid.

It is the desire of the donor that this fund should benefit The Ohio State University at Marion in perpetuity. If the need for this fund should cease to exist or so diminish as to provide unused income, then another use shall be designated by the Foundation Board as recommended by the dean and director of The Ohio State University at Marion, in consultation with the Ohio State Marion Scholarship Committee in order to carry out the desire of the donor.

\$25,000.00

Change in Name and Description of Named Endowed Fund

Dick and Peggy Knowlton Scholarship Fund

The Richard and Margaret Knowlton Scholarship Fund was established February 5, 1999, in accordance with the guidelines approved by the Board of Directors of The Ohio State University Foundation, with gifts designated for support of the Office of Student Financial Aid, from Mr. and Mrs. Dick Knowlton, Bellefontaine, Ohio, and Hilton Head, South Carolina. The name and description were revised on February 1, 2002.

All gifts are to be invested by the Foundation, under the rules and regulations adopted by the Foundation's Board of Directors, with the right to invest and reinvest as occasion dictates.

The annual income shall be distributed to the Office of Student Financial Aid to be used to fund one or more scholarships for worthy undergraduates on any Ohio State University campus with financial need from Logan and Clark Counties, Ohio. The scholarship(s) will be awarded in consultation with the University Committee on Student Financial Aid. Scholarship(s) are renewable upon satisfactory progress toward a degree.

It is the desire of the donors that this fund should benefit the University in perpetuity. If the need for this fund should cease to exist or so diminish as to provide unused income, then another use shall be designated by the Foundation Board in consultation with the director of the Office of Student Financial Aid in order to carry out the desire of the donors.

**EMPLOYMENT OF ARCHITECTS/ENGINEERS,
REQUEST FOR CONSTRUCTION BIDS, AND
REPORT OF AWARD OF CONTRACTS**

Resolution No. 2002-79

WEXNER CENTER – BUILDING RENOVATIONS
UNIVERSITY AIRPORT
PIKETON – TRAINING AND DEVELOPMENT CENTER
WISEMAN HALL – EXPAND ULAR FACILITIES
UTILITIES – NORTH TUNNEL STEAMLINER UPGRADE
PROGRAM IN MATHEMATICAL BIOSCIENCE
MANSFIELD CAMPUS – ROADWAY AND PARKING LOT RESURFACE
RIVERWATCH TOWER – SUITES B AND C
VIVIAN HALL – ROOMS 1-218

Synopsis: Authorization to employ architect/engineering firms for the University Airport, Piketon – Training and Development Center, Wiseman Hall – Expand ULAR Facilities, Program in Mathematical Bioscience, and Mansfield Campus – Roadway & Parking Lot Resurfacing projects, request construction bids for the Wexner Center – Building Renovations, Wiseman Hall – Expand ULAR Facilities, Utilities – North Tunnel Steamline Upgrade, Program in Mathematical Bioscience, Mansfield Campus – Roadway and Parking Lot Resurfacing, and Riverwatch Tower – Suites B and C projects, and acceptance of the report of award of contracts for the Vivian Hall – Rooms 1-218 projects is requested.

WHEREAS the University desires to renovate and rebuild the Wexner Center for the Arts to correct building envelope and system problems, improve public circulation, and enhance security; and

WHEREAS the total estimated project cost is \$10,000,000 and the total estimated construction cost is \$7,000,000, with funding provided by University funds (\$9,000,000) and House Bill 640 (\$1,000,000); and

WHEREAS the University desires to construct a 15 bay aircraft T-hangar, a 12 bay aircraft T-hangar with attached aircraft wash bay and restrooms, an aircraft community hangar with office suites, and an airport maintenance building at Don Scott Field; and

WHEREAS the total estimated project cost is \$7,861,178 in 2004 dollars and the total estimated construction cost is \$6,425,863 in 2004 dollars, with funding provided by University bond proceeds with debt service paid by the College of Engineering; and

WHEREAS the University desires to construct a new training and development center at the OARDC Piketon facilities to provide technology training and a business incubator center; and

WHEREAS the total estimated project cost is \$3,090,000 and the total estimated construction cost is \$2,540,973, with funding provided by an Economic Development Administration grant (\$1,920,000), Appalachian Regional Commission grant (\$270,000), and future capital appropriation (\$900,000);

WHEREAS the University desires to upgrade the first floor conference room, renovate the two surgery locker rooms and add a fourth surgery room in Wiseman Hall to expand facilities for the University Lab Animal Resources; and

WHEREAS the total estimated project cost is \$1,771,420 in 2003 dollars and the total estimated construction cost is \$596,160 in 2003 dollars, with funding provided by National Institute of Health grant (\$885,710), College of Medicine (\$442,855), and Office of Research (\$442,855); and

WHEREAS the University desires to upgrade the north tunnel steamline from McCracken/Neil junction to the north #1 tunnel to meet future demands within that area; and

**EMPLOYMENT OF ARCHITECTS/ENGINEERS,
REQUEST FOR CONSTRUCTION BIDS, AND
REPORT OF AWARD OF CONTRACTS (contd)**

WHEREAS the total estimated project cost is \$1,400,000 and the total estimated construction cost is \$1,190,000, with funding provided by House Bill 640 (\$750,000), House Bill 748 (\$386,550), House Bill 790 (\$11,450) and House Bill 850 (\$252,000); and

WHEREAS the University desires to renovate space in the Mathematics Building and Cockins Hall to house a program in mathematical bioscience; and

WHEREAS the total estimated project cost is \$570,346 and the total estimated construction cost is \$317,571, with funding provided by a Board of Regents grant (\$100,000) and College of Mathematics and Physical Sciences (\$470,346); and

WHEREAS the Mansfield Campus desires to resurface a portion of the main entrance roadway and heavily used parking lots; and

WHEREAS the total estimated project cost is \$370,575 and the total estimated construction cost is \$305,000, with funding provided by House Bill 640 (\$160,000), and House Bill 748 (\$53,300), and North Central Technical College (\$157,275); and

WHEREAS the University desires renovate office space for the University Treasurer's staff located on the ground floor of Riverwatch Tower; and

WHEREAS the total estimated project cost is \$326,612 and the total estimated construction cost is \$270,953, with funding provided by the Office of Business and Finance:

WHEREAS a resolution adopted by the Board of Trustees on June 1, 2001 authorized the President and/or Vice President for Business and Finance to request construction bids in accordance with established University procedures, and if satisfactory bids were received to award contracts for the following projects:

Vivian Hall – Rooms 1 – 218

This project removes partitions and lab benches and installs electrical outlets and lights in various areas within Vivian Hall to temporarily house a portion of the Knowlton School of Architecture. The total project cost is \$305,000; funding is provided by Central University funds (\$152,500) and future University bond proceeds (\$152,500) with debt service paid by gifts to the Knowlton School of Architecture. The estimated completion date is February 2002. The contracts awarded are as follows:

Design:	Phillip Markwood, Columbus, Ohio
General Contract:	Childers Corporation, Columbus, Ohio
Amount:	\$271,474
Estimate:	\$261,000
Total All Contracts:	\$271,474
Contingency Allowance:	\$10,025
Total Project Cost:	\$305,000

NOW THEREFORE

BE IT RESOLVED, That the President and/or Senior Vice President for Business and Finance be authorized to select qualified architectural/engineering firms as necessary for the University Airport, Piketon – Training and Development Center, Wiseman Hall – Expand ULAR Facilities, Program in Mathematical Bioscience, and Mansfield Campus – Roadway & Parking Lot Resurfacing projects and that the fees for these services be negotiated between the firms selected and the University; and

**EMPLOYMENT OF ARCHITECTS/ENGINEERS,
REQUEST FOR CONSTRUCTION BIDS, AND
REPORT OF AWARD OF CONTRACTS (contd)**

BE IT FURTHER RESOLVED, That, subject to the execution of a memorandum of understanding among all the offices involved, the President and/or Senior Vice President for Business and Finance be authorized to request construction bids for the Wiseman Hall – Expand ULAR Facilities project in accordance with established University and State of Ohio procedures, and if satisfactory bids are received, to issue contracts with all actions to be reported to this Board at the appropriate time; and

BE IT FURTHER RESOLVED, That the President and/or Senior Vice President for Business and Finance be authorized to request construction bids for the Wexner Center – Building Renovations, Utilities – North Tunnel Steamline Upgrade, Program in Mathematical Bioscience, Mansfield Campus – Roadway & Parking Lot Resurfacing, and Riverwatch Tower – Suites B and C projects in accordance with established University and State of Ohio procedures, and if satisfactory bids are received, to issue contracts with all actions to be reported to this Board at the appropriate time; and

BE IT FURTHER RESOLVED, That pursuant to the actions previously authorized by the Board, the report of award of contracts and establishment of contingency funds for the Vivian Hall – Rooms 1 - 218 projects is hereby accepted.

(See Appendix XXIII for background information and maps, page 809.)

PURCHASE OF REAL PROPERTY

Resolution No. 2002-80

**CAMPUS VIEW VILLAGE APARTMENTS
929 SHARON VALLEY ROAD, NEWARK, OHIO**

Synopsis: Authorization to purchase improved real property located at 929 Sharon Valley Road, Newark, Ohio, owned by Campus View Village, is proposed.

WHEREAS the Board of Trustees of The Ohio State University is presented with an opportunity to purchase improved real property located at 929 Sharon Valley Road, Newark, Ohio, owned by Campus View Village, an Ohio non-profit corporation, which intends to transfer the property to Newark Campus Development Fund, also an Ohio non-profit corporation; and

Whereas the property has an appraised value of approximately \$2,937,500, and the seller has offered to sell the property at that price; and

WHEREAS the acquisition of this property is critical for the development of student housing at the Newark Regional Campus, and the appropriate University offices have determined that the purchase of this property is in the best interest of the University; and

WHEREAS funding for this purchase will be provided by Student Affairs:

NOW THEREFORE

BE IT RESOLVED, That the President and/or Senior Vice President for Business and Finance be authorized, in the name of the State of Ohio for the use of The Ohio State University, to purchase from Newark Campus Development Fund the property located at 929 Sharon Valley Road, Newark, Ohio at purchase price of \$2,937,500.00, plus closing costs, upon such terms and

PURCHASE OF REAL PROPERTY (contd)

conditions as are deemed to be in the best interest of the University, subject to the University receiving the necessary approvals from the Ohio Board of Regents and the State Controlling Board.

(See Appendix XXIV for background information and map, page 827.)

ACCEPTANCE OF THE REPORT OF AUDIT FOR 2000-2001

Resolution No. 2002-81

Synopsis: The report of the audit of the financial statements for The Ohio State University for 2000-01 conducted by Deloitte & Touche is recommended for acceptance.

WHEREAS, with the approval of the Auditor of State, The Ohio State University entered into a five-year agreement with Deloitte & Touche in February 1996 for an annual audit of the University for fiscal years 1995-96 through 1999-2000; and extended that contract to cover fiscal year 2000-01 to provide continuity for the audit during the first year of implementation of the University's new financial accounting system; and

WHEREAS the Deloitte & Touche audit of the University for 2000-01, meeting the requirements of the Auditor of State, has been received and the accounts, records, files, and reports of the University have been found to be in satisfactory condition, and certain internal control recommendations have been discussed with the Fiscal Affairs Committee; and

WHEREAS the auditors' internal control recommendations are being reviewed by the appropriate University offices, and appropriate procedures and responses are being developed as a result of these recommendations:

NOW THEREFORE

BE IT RESOLVED, That the report of the Deloitte & Touche audit for The Ohio State University for 2000-01, including the report on the audit of the University's financial statements and the summary of significant internal control recommendations to management, be accepted.

**CAMPUS PARTNERS
RELEASE OF REMAINING FUNDING**

Resolution No. 2002-82

Synopsis: Release of remaining funding of \$1,600,000 for Campus Partners' initiatives from the previously identified \$25 million set-aside is recommended.

WHEREAS in February and November 1995 the Board of Trustees recognized the critical need for revitalization of the High Street and residential areas adjacent to the Columbus Campus and the importance of the initiatives of Campus Partners for Community Urban Redevelopment, Inc., in this effort and identified \$25 million in Endowment funds that could be made available for real estate and related investments in support of the Campus Partners revitalization efforts; and

WHEREAS in May 1997, July 2000, August 2000, and December 2001, the Board of Trustees authorized, subject to a memorandum of understanding of May 1, 1997, the release of up to \$23.4 million of the \$25 million identified for investment in the University Gateway Center and other real estate investments; and

**CAMPUS PARTNERS
RELEASE OF REMAINING FUNDING (contd)**

WHEREAS Campus Partners is nearing completion of the acquisition of the Gateway Redevelopment Area, as well as completion of related environmental remediation, demolition, and relocation of businesses associated with building in the area; and

WHEREAS there is a need for use of the remaining \$1.6 million of the \$25 million set-aside to complete these efforts:

NOW THEREFORE

BE IT RESOLVED, That the Board of Trustees hereby authorizes further investment in Campus Partners through the release of the remaining \$1,600,000 of the previously identified \$25 million in Endowment funds for Campus Partners' use of these funds and any remaining previously released funds for purchase of additional real estate for the University Gateway Center and to carry out remaining activities associated with Campus Partners' real estate investments; and

BE IT FURTHER RESOLVED, That this authorization and release of funds shall be subject to whatever further provisions amending the memorandum of understanding of May 1, 1997, as the Oversight Committee shall determine appropriate.

BUDGET VERSUS ACTUAL REPORT

Resolution No. 2002-83

Fiscal Year 2000-01

Synopsis: The budget versus actual report for FY 2000-01 is submitted for approval.

WHEREAS the FY 2000-01 audit of the University's income and expenditures is now complete; and

WHEREAS the current funds budget for FY 2001 has been compared with the audited income and expenditures for FY 2001 and any significant variances explained:

NOW THEREFORE

BE IT RESOLVED, That the budget versus actual report for FY 2001 be approved.

(See Appendix XXV for background information, page 829.)

Upon motion of Ms. Longaberger, seconded by Mr. Sofia, the Board of Trustees adopted the foregoing resolutions by unanimous roll call vote, cast by Messrs. Brennan, Patterson, Sofia, Slane, and McFerson, and Mses. Longaberger and Davidson.

--0--

Thereupon the Board adjourned to meet Friday, March 1, 2002, at The Ohio State University Longaberger Alumni House, Columbus, Ohio.

Attest:

William J. Napier
Secretary

David L. Brennan
Chairman

Analysis and Recommendations
Regarding Funding Strategies
OSU Columbus Campus

The Ohio State University Board of Trustees
February 1, 2002

Office of Academic Affairs
Office of Business and Finance
January 31, 2002

- I. What are the broader goals for Ohio State?
- II. What does the University recommend and why?
- III. What are the implications and what happens next?

I. What are our strategic objectives and why?

To be successful in the 21st century, Ohio needs a strong system of education, including a top tier comprehensive teaching and research institution.

Such an institution is critical because it:

1. Provides an opportunity for talented high school graduates in Ohio to learn and grow in a research environment that gives them a competitive edge in the knowledge economy.
2. Attracts talented faculty and students to Ohio from all over the world.
3. Serves as a catalyst to grow the State's economy, which provides more jobs and better jobs for all of Ohio's citizens.
4. Serves as a focal point for a variety of activities that improve the quality of life for all Ohioans.

What needs to be done?

Comparisons with the best public universities show that OSU does a very good job; but needs to do a better job for its undergraduates in the following areas:

- Retention of top faculty and support staff.
- Increased direct involvement for undergraduate students with regular faculty.
- Better access to high demand courses.
- Improved academic and career counseling.
- Wider availability of state of the art learning technology.
- More learning and service experiences outside the classroom.
- A more supportive physical environment.

Why resources matter

Comparisons with other top public universities as part of the academic planning process also show that while resources alone do not guarantee success, a measurable lack of resources has limited Ohio State's ability to meet the needs of its students.

- Top institutions in other states receive roughly 20% more in revenue per student FTE than OSU's Columbus campus.
- Relatively low state support and low undergraduate tuition alone account for a gap of more than \$900 annually per undergraduate student FTE.
- This disparity is likely to grow if strong action is not taken.
- All other alternatives, such as cuts and reallocations, have been exhausted.

A competitive disadvantage v. comparable universities

Historically low levels of state support and resident undergraduate tuition have placed OSU at a competitive disadvantage in addressing the needs of our students.

Category	Total Tuition and State Support/FTE	Difference (OSU v. category)
OSU Columbus Campus	\$14,319	-0-
Benchmark Mean	15,289	(\$970)
Benchmark Median	14,818	(499)
Big Ten Public Mean	15,682	(1,363)
Big Ten Public Median	15,121	(802)
Average		(\$909)

$$\$909 \times 30,000 \text{ undergraduate FTE} = \$27,000,000$$

...and the situation is getting worse as state support declines::

	Year	Nominal Amount
State support (State Share of Instruction) per student FTE OSU Columbus Campus:	FY 2001	\$7,285
	FY 2002	\$6,907
	FY 2003	\$6,887

Decline in state support from FY 2001 to FY 2003: $\$7,285 - 6,887 = \398^1

$\$398 \times 30,000$ FTE undergraduate students = \$12 million

¹ Figures not adjusted for inflation. If a 3% annual inflation adjustment is used, the reduction is \$842 per student, or a decline of \$25 million in purchasing power.

OSU also faces a competitive disadvantage with other Ohio schools.

Even though a formula distributes state aid uniformly based on level of instruction, undergraduate tuition at OSU's Columbus campus is \$1,253 less than the average of Ohio's other selective admission public universities (\$1,253 x 30,000 undergraduate FTE = \$37.6M).

Institution	Current Tuition ²
Miami	\$6,916
Cincinnati	6,172
Kent State	5,874
Bowling Green	5,748
Ohio University	5,493
Average	\$6,041

Ohio State	\$4,788
Difference	\$1,253

² Includes mid-year increase already announced.

Lower resources mean less support in critical areas

Educational and general expenditures per student FTE, OSU v. benchmark average (FY 1997-1999):

Student Services (e.g., service learning, career counseling, etc.)	- 9%
Scholarships and Fellowships	- 31%
Physical Plant (e.g., plant, operation and maintenance)	- 36%
Academic Support (e.g., instructional technology)	- 39%
Research	- 47%
All Expenses	- 19.5%

Ohio State has exhausted all other options

- A. In Spring 2001, OSU made a strategic decision to hold back on faculty and staff pay raises in FY 2002 in order to protect student and instructional programs.
- B. In Spring 2001, OSU informed enrolled students that resident undergraduate tuition would likely increase at 9% a year for the next 4-5 years until OSU is in third or fourth place among state institutions.
- C. In FY 2002, state support fell below student tuition income for the first time in the University's 131-year history.
- D. In order to protect its students from unanticipated additional tuition increases, OSU did not do a tuition increase in Winter or Spring Quarters, despite a mid-year reduction in state support.
- E. OSU has restructured its budget process to provide greater incentives to colleges and support units to increase revenues and reduce costs, consistent with the goals of the Academic Plan.
- F. OSU has tried to maximize other funding sources, including:

Private giving (up 17% in CY 2001)

Sponsored research (up 18% in CY 2001)

Charges to non-General Fund units for central support services (e.g., Athletics) (\$28M)

...and OSU will continue to implement significant cost reductions:

- Funding for central initiatives will be reduced 10% for FY 2003
- Support units will reduce or reallocate from 3.5% to 7% of their budgets for FY 2003
- Colleges will reduce or reallocate from 2.5% to 5% of their budgets for FY 2003
- Additional targeted cost reduction initiatives include:
 - * Healthcare benefit costs (co-pays increased in FY 2002)
 - * Purchasing practices review of key commodities
 - * Energy savings through competitive bidding/conservation
 - * University-wide computer systems review to reduce redundancies

The University faces a \$73 million General Fund problem in FY 2003

Amount of increased resources needed to meet academic goals:

Compensation (including benefits)	\$30-34M
-----------------------------------	----------

Scholarships and Financial Aid	11-12M
--------------------------------	--------

All Other (includes Selective Investment, enhanced recruiting, legal mandates, etc.)	<u>8-11 M</u>
--	---------------

Total	\$49-57M
-------	----------

Mid-point	\$ 53M
-----------	--------

Plus amount need to absorb state FY 2002 budget cuts to General Fund (including Success Challenge)	<u>\$ 20M</u>
--	---------------

Total Need	\$ 73M
------------	--------

\$60 million has been identified already

Even after \$20 million in cuts to unit budgets, \$16 million in additional reallocations and other revenues and previously planned tuition increases of \$24 million, a \$13 million need remains:

Budget Cuts		\$20M
Additional Reallocations and Other Revenues		\$16M
Previously Planned Tuition Increases		\$24M
Undergraduates 9%	(\$13.8M)	
Graduate & Professional General and Non-resident surcharge 5%	(\$10.2M)	
	Total	\$60M
Amount Still Needed		<u>\$13M</u>
Solution		\$73M

What Options Were Considered?

Assumptions:

- \$13 million target
- Base fee increase = 9%
- Differential for new v. current students

	Increase to Students	New Annual Tuition	FY 03 Additional Revenues above 9% Base (in millions)
Option A			
All Students	9%	\$5,217	0
New Students	+1,575	6,792	<u>13</u>
			13
Option B			
All Students	12%	5,358	5
New Students	+999	6,357	<u>8</u>
			13
Option C			
All Students	9%	5,217	0
New Students	+1,200	6,417	<u>11</u>
			11

II. What does the University recommend and why?

The University Administration is guided by the following principles in recommending a tuition strategy, consistent with the Academic Plan:

1. We need to maintain our commitment to enhancing academic quality (even during the current recession), as this is critical to our students, Ohio's longer-term economic vitality and competitiveness.
2. We need to continue to do all we can internally to reduce costs and program new and existing resources to offset the state budget reductions and address competitive compensation needs.
3. Our tuition policy should be as fair as possible to current undergraduate students, placing a greater responsibility on incoming students.
4. Financial aid must increase so that students who meet academic requirements but qualify for financial aid will still be able to attend OSU.
5. A high priority for use of the increased resources will be to preserve and improve the quality of the student experience both inside and outside the classroom.

Recommendations

For all undergraduates (new and continuing) there would be a 9% increase in instructional and general fees beginning Summer Quarter 2002. This will amount to a \$429 increase from \$4,788 to \$5,217 for full-time undergraduates over a three quarter (academic year) period.

For new students, there would be an additional \$400 per quarter (\$1,200 per three quarter academic year) increase in the instructional fee above the 9% beginning Summer Quarter 2002.

New students means any undergraduates starting at Ohio State (Columbus or Regional Campus) Summer Quarter 2002 or later. Continuing students means any undergraduates starting at Ohio State (Columbus or Regional Campus) prior to Summer Quarter 2002.

Current students would be grandfathered (exempted) from the new higher rates for four years (through FY 2006).

These recommendations apply to Columbus Campus only. Recommendations for regional campuses will be determined after they have had a chance to consult with their advisory boards.

Increase student financial aid funds to assure that students who are otherwise qualified will be afforded access.

These recommendations are based on levels of state support in HB 405. If those levels change, recommendations may have to be modified.

An additional \$2 million will be identified through a combination of additional spending reductions, reallocations and income increases.

These recommendations mean that planned and additional undergraduate tuition increases will contribute no more than \$29 million to the FY 2003 solution of a \$73 million problem.

OSU will remain affordable

Ohio State will remain affordable compared to other public universities, even if those universities increase FY 2003 tuition by a smaller percentage amount.

For example, if other Ohio universities increase tuition by 6%, OSU will rank:

8th out of 13 on tuition for current students, and
4th out of 13 for new students

If other Big Ten universities raise tuition by the amount already announced and by 10% for those who have not yet announced, OSU will rank:

7th out of 10 for current students, and
5th out of 10 for new students.

If other Benchmark universities raise tuition by 10%, or the amount already announced, OSU will rank:

5th out of 10 for current students, and
4th out of 10 for new students.

Compared to other Ohio universities, tuition for current students at Ohio State will remain about average.

Possible Fall 2002 Tuition
OSU v. Other Ohio Publics

Current Students Only

University	FY 2002 Tuition	FY 2003 Assumed Tuition
Miami	\$6,916	\$7,331
University of Cincinnati	6,172	6,542
Kent State	5,874	6,226
Bowling Green	5,748	6,093
Ohio University*	5,493	6,000
Akron	5,177	5,488
Toledo	5,102	5,408
Ohio State	4,788	5,217
Cleveland State	4,732	5,016
Wright State	4,596	4,872
Youngstown State	4,204	4,456
Central State	3,723	3,946
Shawnee State	3,402	3,606
Average	5,071	\$5,400

Note: Projection for illustrative purposes only, except where respective schools have already announced a figure for FY 2003 as indicated by an asterisk. Assumes a 9% increase for OSU and a 6% increase for all other Ohio universities. Actual increase will be determined by those institutions and may vary.

Tuition for new students will likely be in the middle of the first quartile for new students at other Ohio publics, even if the percentage increase at other schools is less.

Possible Fall 2002 Tuition
OSU v. Other Ohio Publics

New Students

University	FY Assumed Tuition
Miami	\$7,331
Ohio University*	6,564
University of Cincinnati	6,542
Ohio State	6,417
Kent State	6,226
Bowling Green	6,093
Akron	5,488
Toledo	5,408
Cleveland State	5,016
Wright State	4,872
Youngstown State	4,456
Central State	3,946
Shawnee State	3,606
Average	\$5,535

NOTE: Projected tuition is for illustrative purposes only. Assumes a 9% + \$1,200 increase for OSU and a 6% increase for all other Ohio universities unless accompanied by an asterisk, which indicates announced increase for FY 2003. Actual increases will be determined by each institution and may vary.

Tuition for new students will remain in the middle of the Big Ten public universities, even if the percentage increase for other schools is less.

Possible Fall Tuition
OSU v. Big Ten

New Students Only

University	FY 2003 Assumed Tuition
Penn State*	\$8,165
Michigan*	7,854
Illinois*	6,504
Michigan State*	6,438
Ohio State	6,417
Minnesota	6,090
Purdue*	5,621
Indiana	5,207
Wisconsin	4,495
Iowa*	4,190
Average	6,098

Note: The figures for FY 2003 are projections by OSU and do not reflect projections or decisions by the other respective universities, except where indicated with an asterisk (). The asterisk indicates that a decision has already been publicly announced. Tuition for all other universities is assumed to increase at 10%, except Ohio State where a 9% + \$1,200 increase is shown. Actual increases may vary.*

III. Implications

- A. Progress on academic goals will be maintained, but at a slower pace. The phased in nature of the higher tuition on new students will provide a steady stream of \$6-7 million in additional funds net of financial aid annually to help support the Academic Plan over the next 5 years.
- B. Access for academically qualified students will be maintained
- C. Students will benefit directly
- D. OSU will remain a unique combination of excellence and affordability.
- E. Next steps

*Continued access for students will be maintained
regardless of their financial resources*

- University funds for student financial aid will be increased for current students.
- The increase in tuition for current students will be less than for new students.
- Financial aid will also be increased for new students.

How students will benefit

Ohio State will continue to make progress in better serving its students and the citizens of Ohio.

Impact of reductions in state support will be softened:

- Retention of current outstanding faculty and staff will be more successful, keeping class size down and quality and course availability up.
- Core student services such as student financial aid processing, course registration, disability services and public safety will be preserved.

Other improvements will continue, although at a slower pace:

- Smaller classes.
- Improved access to courses (fewer closeouts).
- Better access to state of the art technology.
- Improved academic counseling.
- More high quality learning experiences outside the classroom.

What Happens Next

1. Board approval needed by March 1, 2002 so we can inform next year's continuing and new students know what to expect before they make enrollment decisions for next Fall.
2. All other fees and charges will be determined later this Spring as part of the regular budget process.
3. Distribution of funds will be determined as part of the FY 2003 budget process (late Spring/early Summer).
4. These numbers are based on current information and are subject to change in the event of an unpleasant surprise(s).

Summary

1. A principled commitment to continue to improve the University's academic standing is critical to our students' future and the future of Ohio.
2. This commitment must be pursued despite historically weak state support and weakness in the state's economy.
3. The University has taken significant steps to achieve cost efficiencies and to increase revenue from other sources.
4. Nevertheless, a significant increase is needed in tuition for the 2002 – 2003 academic year in order to preserve progress already made and to make additional progress.
5. The strategy recommended will limit the burden on current students.
6. Financial aid funds will be increased for all students (including new students) so students who are otherwise qualified will not be denied admission for financial reasons.
7. Even after the proposed increases, the University's tuition still will not exceed the mid-point of Big Ten public universities or the middle of the upper quartile of Ohio public universities.
8. The additional funds will be used to preserve gains already made by providing market level compensation to faculty and staff and to continue to make improvements in student life both inside and outside the classroom, which is critical to the success of the Academic Plan.
9. The Ohio State University will continue to be a great investment for our students and for the people of Ohio.

Wexner Center - Building Renovations**315-2000-914****PROJECT CAPTAIN:**

Scott Conlon, Facilities Planning & Development - Architecture, 292-0983

REQUESTING AGENCY:

Wexner Center for the Arts

PROJECT LOCATION:

0386-WEXNER CENTER FOR THE ARTS

AGE:

1989

GR. SQ. FT.:

130,349

PROJECT DESCRIPTION:

Renovation and retrofit of the Wexner Center for the Arts to correct building envelope and system problems, improve public circulation, and enhance security.

MILESTONES:

	Projected	Revised	Actual
Arch/Eng Approved B/T	8/30/2000		2/2/2001
Constr Mgr Approved B/T	4/6/2001		4/6/2001
Bidding Approved B/T	9/1/2001	2/1/2002	
Arch/Engr Contract	1/12/2001	6/23/2001	6/26/2001
Schematic Design Approval	5/4/2001	1/15/2002	
Design Development Approval	9/21/2001	4/1/2002	
Construction Document Approval	3/8/2002	6/15/2002	
Bid Opening	4/10/2002	8/15/2002	
Award of Contracts	5/24/2002	9/15/2002	
Construction Start	5/25/2002	9/30/2002	
Report of Award to B/T	6/1/2002	9/30/2002	
Completion	11/29/2003	9/1/2003	

FUNDING INFORMATION:

Centrally Funded Capital Projects	\$	-	\$	9,000,000
HB640 Basic Renovations		1,000,000		1,000,000
Total	\$	1,000,000	\$	10,000,000

USES:

Constr. Mgr.	\$	-	\$	420,000
Construction				7,000,000
Contingency		200,000		876,000
Design		800,000		895,000
Relocation				515,000
Testing				210,000
Univ. Administration				84,000
Total	\$	1,000,000	\$	10,000,000

COMMENTS:

Initial project budget of \$1 million was to provide the feasibility, preliminary design, and cost estimate for the project. Project cost has been identified as \$10 million.

Wexner Center - Building Renovations

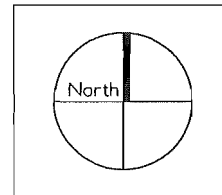
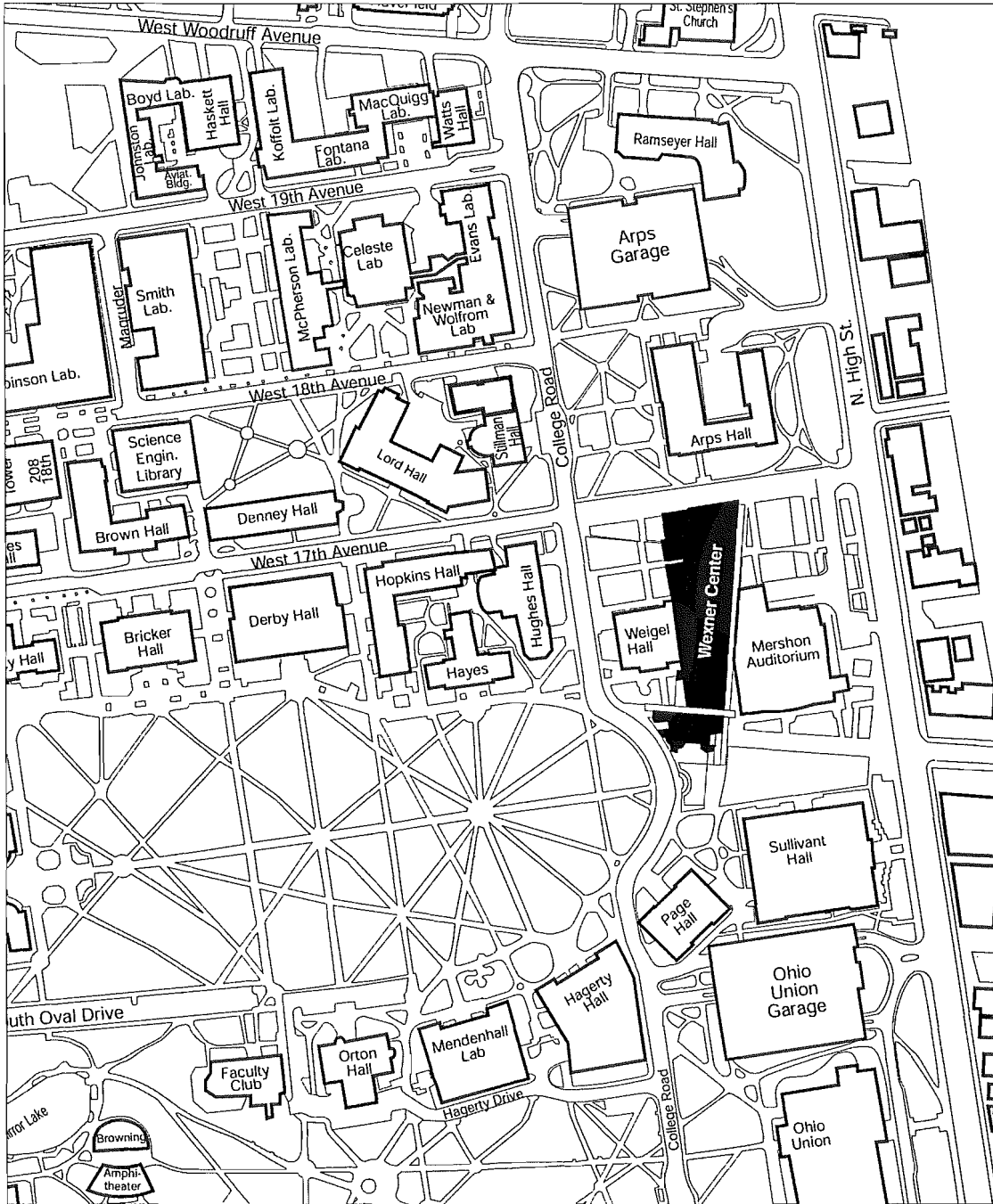

Office of Business and Finance
Office of Facilities Planning and Development

December 9, 2000

University Airport**315-2001-927****PROJECT CAPTAIN:**

Craig C. Henry, Facilities Planning & Development - Architecture, 292-2156

REQUESTING AGENCY:

College of Engineering

PROJECT LOCATION:

V0002-Various Locations-Franklin County

AGE:**GR. SQ. FT.:****PROJECT DESCRIPTION:**

The retention of an engineer to develop plans and specifications for a 15 bay aircraft T-hangar, a 12 bay aircraft T-hangar with attached aircraft wash bay and restrooms, an aircraft community hangar with attached office suites, and an airport maintenance storage building. Also included is the demolition of an existing aircraft T-hangar and associated site resurfacing.

MILESTONES:

	Projected	Revised	Actual
Arch/Eng Approved B/T	2/1/2002		
Bidding Approved B/T	4/4/2003		
Arch/Engr Contract	4/30/2002		
Schematic Design Approval	9/30/2002		
Design Development Approval	1/31/2003		
Construction Document Approval	5/30/2003		
Bid Opening	7/15/2003		
Award of Contracts	9/8/2003		
Construction Start	9/15/2003		
Report of Award to B/T	10/3/2003		
Completion	8/31/2004		

FUNDING INFORMATION:

Future Univ. Bond Issues	\$	7,861,178	
Total	\$	7,861,178	

USES:

Bond Financing	\$	385,552	
Construction		6,425,863	
Contingency		321,293	
Design		617,280	
Univ. Administration		111,190	
Total	\$	7,861,178	

COMMENTS:

Costs reflect 2004 dollars. Site to be at Don Scott Field.

University Airport

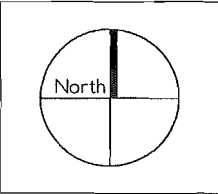
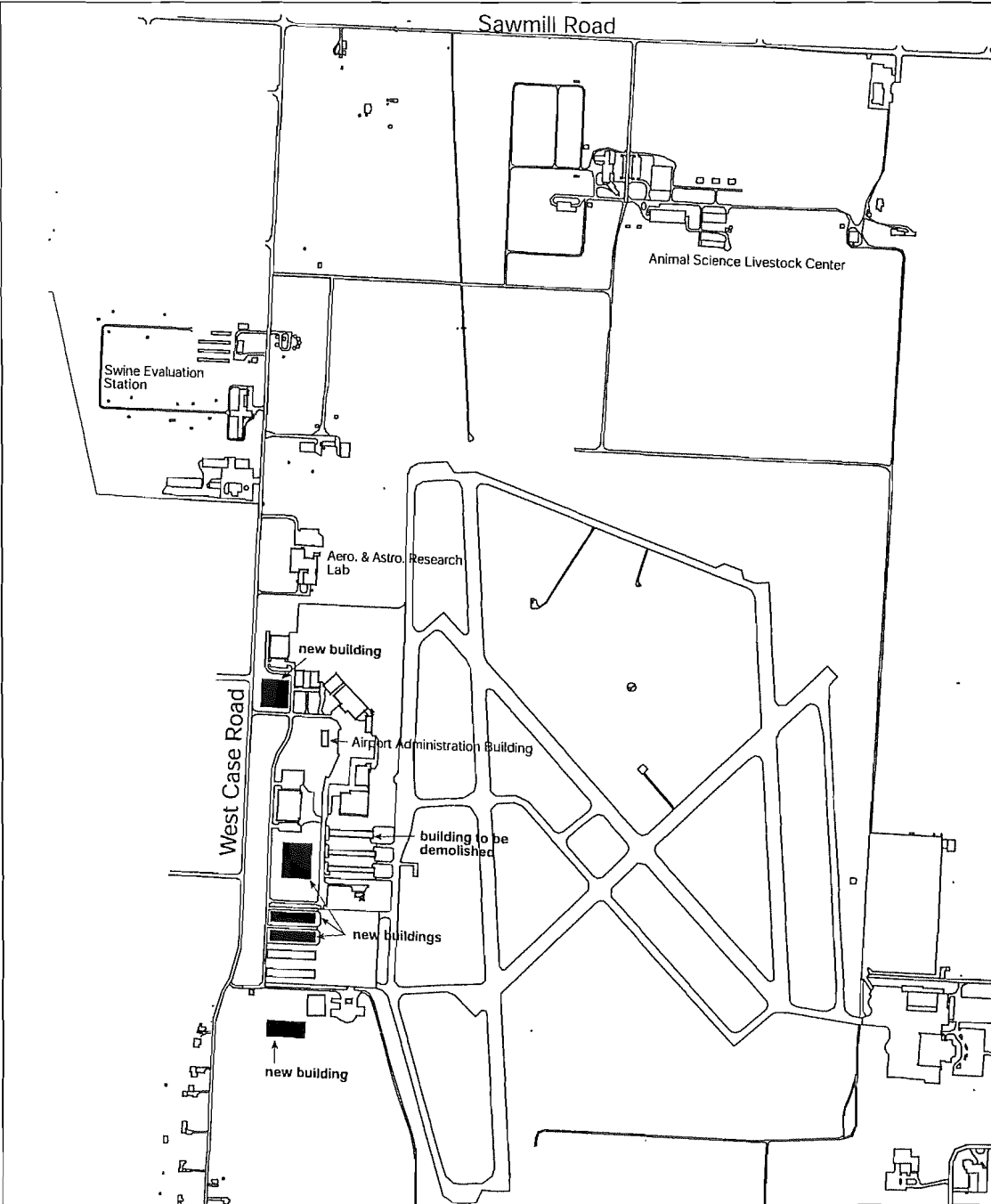

Office of Business and Finance
Office of Facilities Planning and Development

January 12, 2002

OARDC Piketon Training & Development Center**315-2002-901****PROJECT CAPTAIN:**

Steve Middleton, Facilities Planning & Development - Architecture, 688-3576

REQUESTING AGENCY:

Ohio Agricultural Research and Development Center

PROJECT LOCATION:

V0010-Site - See Comments

AGE:**GR. SQ. FT.:****PROJECT DESCRIPTION:**

Construct a new Multi-Purpose Building at Piketon for use by OARDC. New building will provide space for technology training and a business incubator center.

MILESTONES:

	Projected	Revised	Actual
Arch/Eng Approved B/T	2/1/2002		
Bidding Approved B/T	2/7/2003		
Arch/Engr Contract	7/30/2002		
Schematic Design Approval	11/15/2002		
Design Development Approval	11/15/2002		
Construction Document Approval	3/19/2003		
Bid Opening	4/23/2003		
Award of Contracts	6/18/2003		
Construction Start	7/7/2003		
Report of Award to B/T	9/1/2003		
Completion	6/7/2004		

FUNDING INFORMATION:

Future Capital Appropriations	\$	900,000		
Grant-Appalachian Reg. Commission		270,000		
Grant-Economic Development Admin		1,920,000		
Total	\$	3,090,000		

USES:

Construction	\$	2,540,973		
Contingency		254,101		
Design		203,280		
Equipment		53,531		
Univ. Administration		38,115		
Total	\$	3,090,000		

COMMENTS:

Site to be on the OARDC Piketon Facilities.

OARDC Piketon Training and Development Center

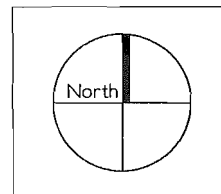
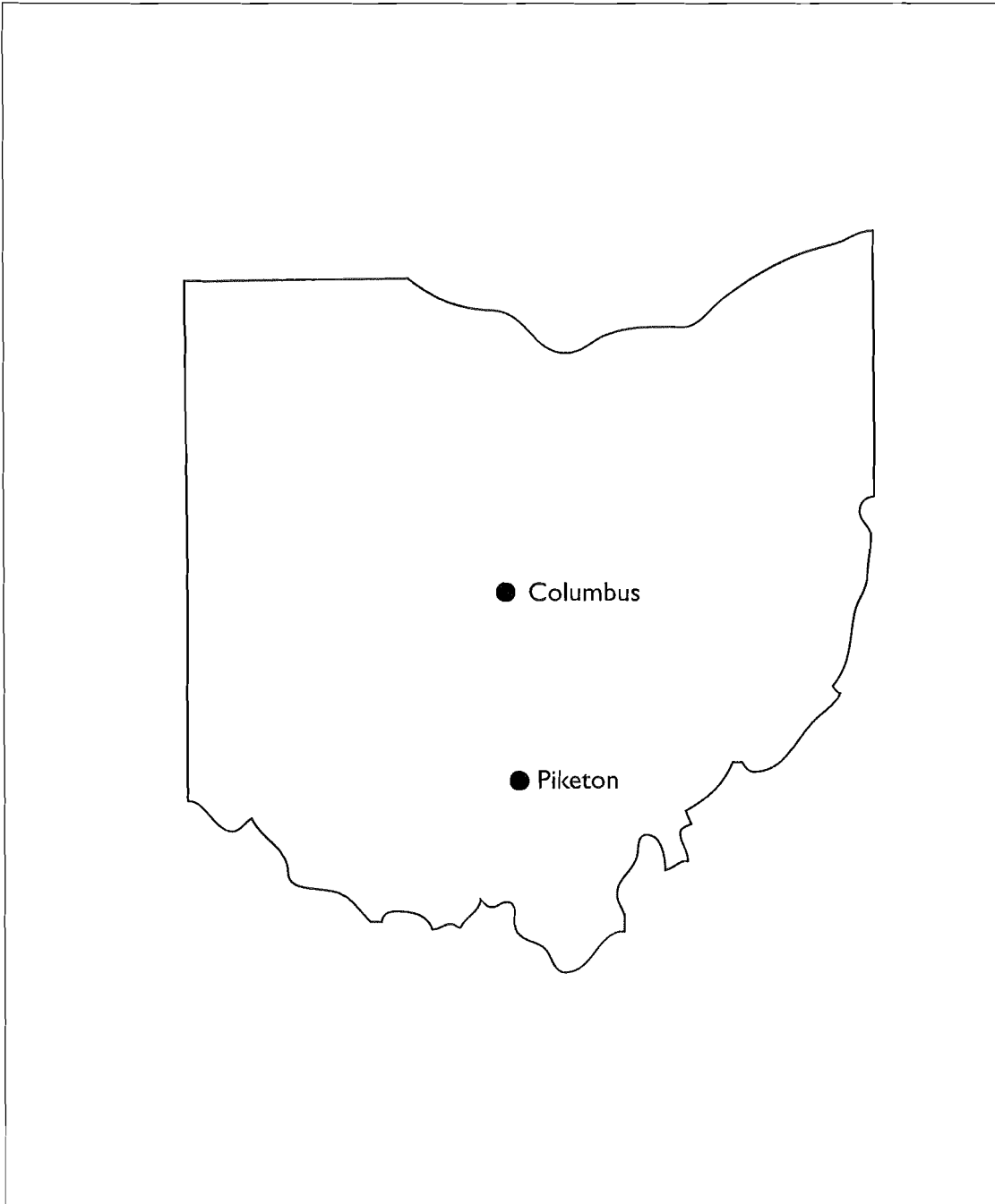

Office of Business and Finance
Office of Facilities Planning and Development

January 25, 2002

Wiseman Hall - Expand ULAR Facilities

315-2002-902

PROJECT CAPTAIN:

Steve Middleton, Facilities Planning & Development - Architecture, 688-3576

REQUESTING AGENCY:

College of Medicine

PROJECT LOCATION:

0157-WISEMAN HALL, BRUCE K.

AGE:

1960

GR. SQ. FT.:

81,714

PROJECT DESCRIPTION:

Upgrade the first floor conference room, renovate the two surgery locker rooms, and add a fourth surgery room within Wiseman Hall.

MILESTONES:

	Projected	Revised	Actual
Arch/Eng Approved B/T	2/1/2002		
Bidding Approved B/T	2/1/2002		
Arch/Engr Contract	7/30/2002		
Schematic Design Approval	11/1/2002		
Design Development Approval	11/1/2002		
Construction Document Approval	2/5/2003		
Bid Opening	3/12/2003		
Award of Contracts	5/7/2003		
Construction Start	5/26/2003		
Report of Award to B/T	6/7/2003		
Completion	2/9/2004		

FUNDING INFORMATION:

Grant-National Institute of Health	\$	885,710		
General Funds-Medicine		442,855		
General Funds-Research		442,855		
Total	\$	1,771,420		

USES:

Construction	\$	596,160		
Contingency		59,616		
Design		72,450		
Equipment		1,034,252		
Univ. Administration		8,942		
Total	\$	1,771,420		

COMMENTS:

Project cost in 2003 Dollars.

Wiseman Hall - Expand ULAR Facilities

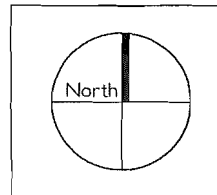
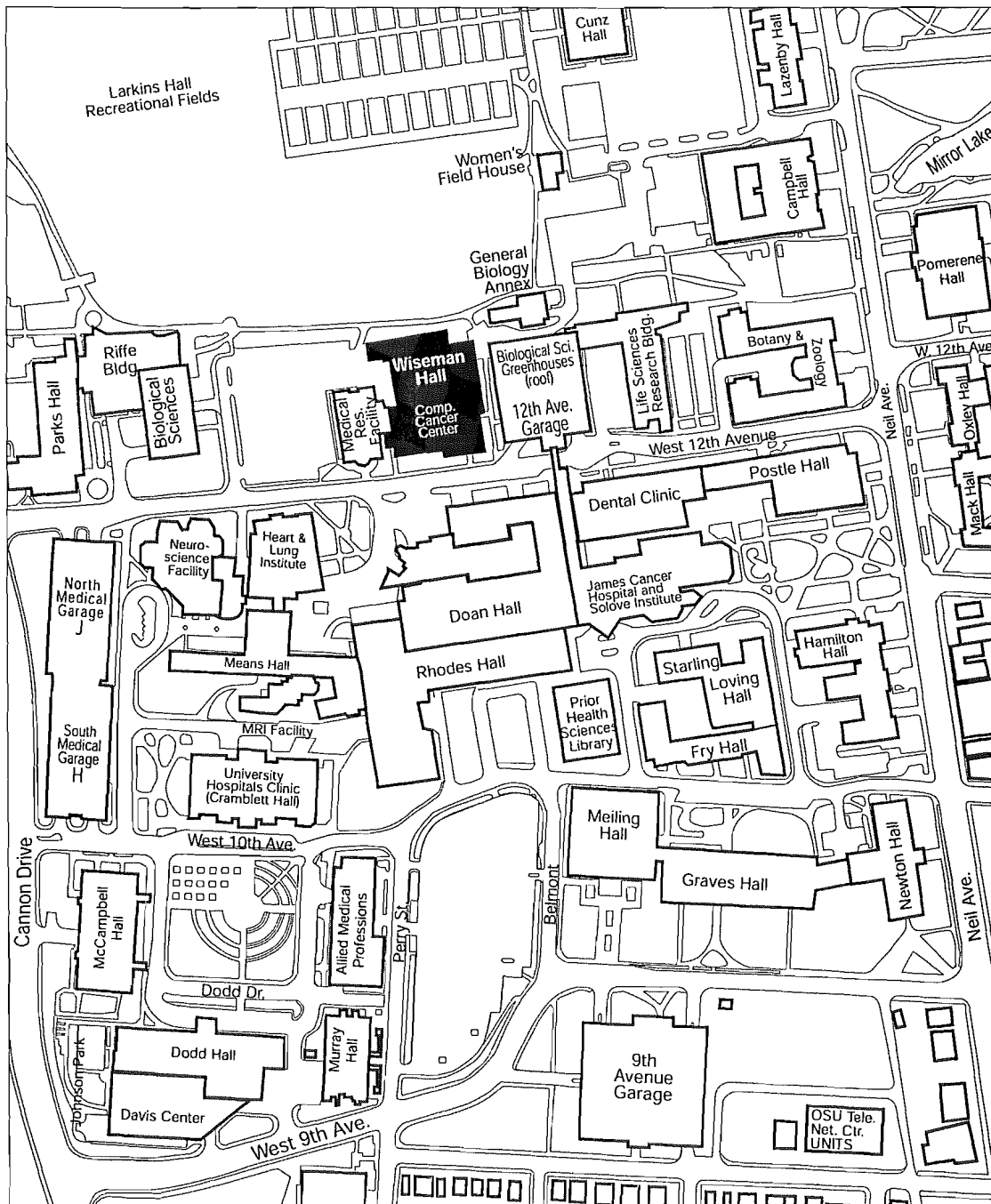

Office of Business and Finance
Office of Facilities Planning and Development

January 10, 2002

Utilities - North Tunnel Steamline Upgrade

315-2000-933

PROJECT CAPTAIN:

Tricia Petras, Physical Facilities UEO, 292-1349

REQUESTING AGENCY:

Department of Physical Facilities

PROJECT LOCATION:

U0000-Unidentified Utility-Col.

AGE:

GR. SQ. FT.:

PROJECT DESCRIPTION:

The existing steamline from McCracken/Neil junction to the North #1 tunnel is undersized to meet demands. This project will remove 1,000 feet of existing asbestos covered 8" line and replace with 12" line and will replace the companion condensate line.

MILESTONES:

	Projected	Revised	Actual
Arch/Eng Approved B/T	11/3/2000		11/3/2000
Bidding Approved B/T	11/3/2000		11/3/2000
Arch/Engr Contract	4/1/2001	5/1/2002	
Schematic Design Approval	7/1/2001	8/1/2002	
Design Development Approval	10/1/2001	8/1/2002	
Construction Document Approval	1/1/2002	11/1/2002	
Bid Opening	3/1/2002	1/1/2003	
Award of Contracts	5/1/2002	3/1/2003	
Construction Start	5/15/2002	4/1/2003	
Report of Award to B/T	12/1/2002	6/1/2003	
Completion	10/15/2002	9/1/2003	

FUNDING INFORMATION:

HB640 Basic Renovations	\$ 750,000	\$ 750,000	
HB748 Columbus Basic Renovation	-	386,550	
HB790 Columbus Basic Renovation	-	11,450	
HB850 Columbus Basic Renovation	-	252,000	
Total	\$ 750,000	\$ 1,400,000	

USES:

Construction	\$ 622,500	\$ 1,190,000	
Contingency	55,915	94,570	
Design	62,250	97,580	
Univ. Administration	9,335	17,850	
Total	\$ 750,000	\$ 1,400,000	

COMMENTS:

\$750,000 project approved by the Board of Trustees on November 3, 2000. Project scope increased to add new OSHA requirements and additional asbestos abatement work. Revised project budget of \$1.4 million presented to the Board of Trustees for approval on February 1, 2002.

Utilities - North Tunnel Steam Line Upgrade

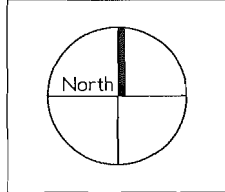
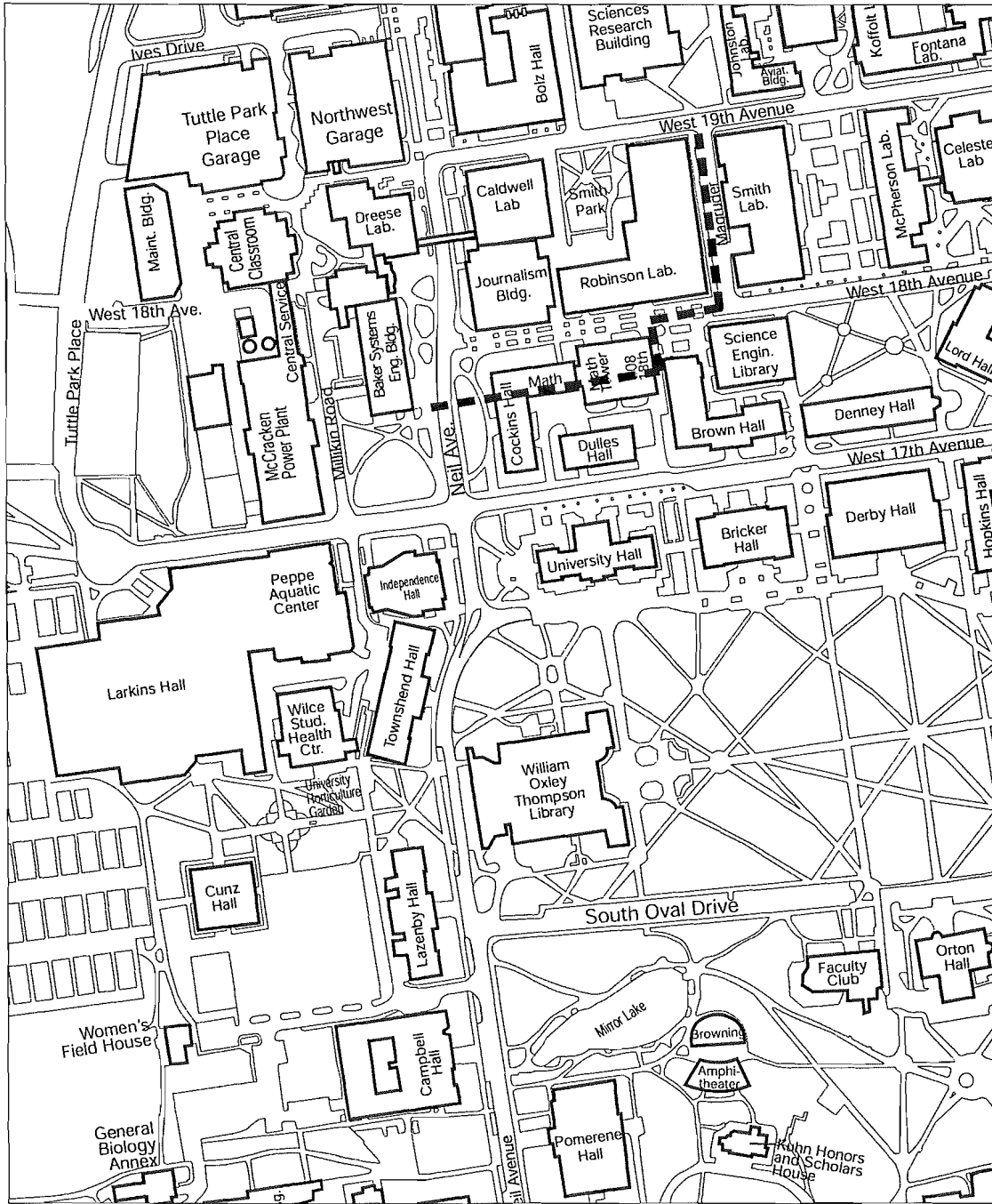

Office of Business and Finance
Office of Facilities Planning and Development

January 12, 2002

Program in Mathematical Bioscience**315-2002-900****PROJECT CAPTAIN:**

Ruth Miller, Facilities Planning & Development - Architecture, 292-4240

REQUESTING AGENCY:

Mathematical & Physical Science

PROJECT LOCATION:

0187-MATHEMATICS BUILDING

AGE:

1962

GR. SQ. FT.:

28,569

PROJECT DESCRIPTION:

Renovate approximately 6,500 square feet of space on the 2nd floor of the Math Building and Cockins Hall to house a program in Mathematical Bioscience. Work includes selective demolition, painting, carpeting, new ceilings and lighting, minor mechanical upgrades, data and electrical upgrades, audio/visual equipment and furniture, and ADA upgrades to the 2nd floor restrooms in Cockins Hall.

MILESTONES:

	Projected	Revised	Actual
Arch/Eng Approved B/T	2/1/2002		
Bidding Approved B/T	2/1/2002		
Arch/Engr Contract	2/15/2002		
Schematic Design Approval	2/20/2002		
Construction Document Approval	2/28/2002		
Construction Start	3/1/2002		
Report of Aware to B/T	12/6/2002		
Completion	8/15/2002		

FUNDING INFORMATION:

Board of Regents	\$	100,000	\$	-
General Funds-Math & Physical Science		470,346		
Total	\$	570,346	\$	-

USES:

Asbestos	\$	45,000	\$	-
Construction		317,571		
Contingency		25,811		
Design		25,000		
Equipment		152,200		
Univ. Administration		4,764		
Total	\$	570,346	\$	-

COMMENTS:

Formerly known as project 50700-R011662. \$235,173 of CMPS funding is pending funding from external sources.

Program in Mathematical Bioscience

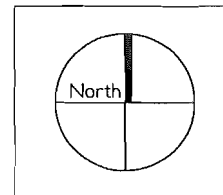
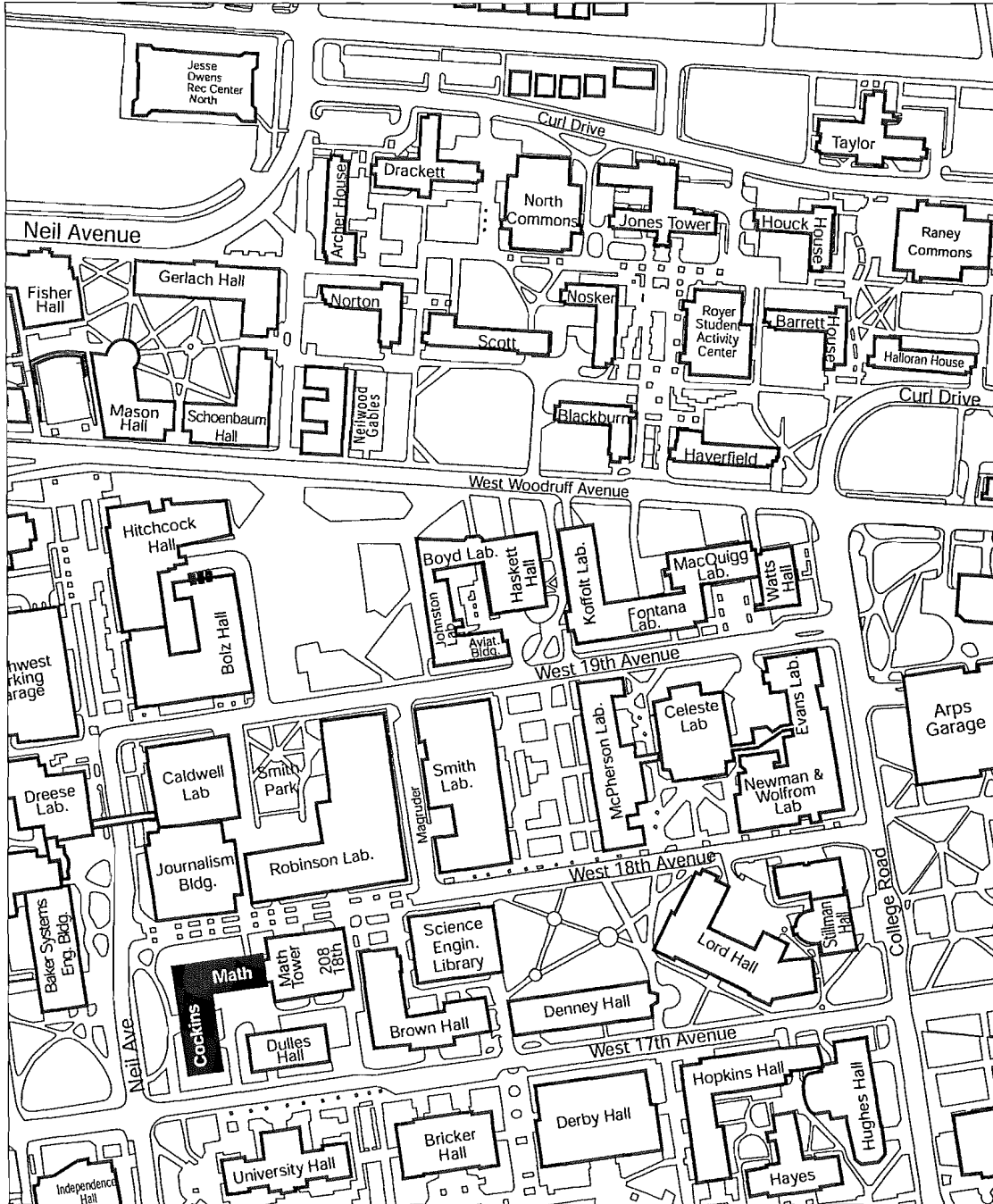

Office of Business and Finance
Office of Facilities Planning and Development

January 31, 2002

Mansfield Campus - Roadway & Parking Lot Resurface

315-2000-947

PROJECT CAPTAIN:

Martin R. Bricker, Facilities Planning & Development - Architecture, 468-0024

REQUESTING AGENCY:

Mansfield Regional Campus

PROJECT LOCATION:

V0004-Various Locations-Mansfield

AGE:

GR. SQ. FT.:

PROJECT DESCRIPTION:

Resurface approximately 1/2 mile long Mansfield main entrance roadway and heavily used parking lots (#4, #5, #6 and Tech Center). Work includes associated storm drain inlet repairs and striping.

MILESTONES:

	Projected	Revised	Actual
Arch/Eng Approved B/T	2/1/2002		
Bidding Approved B/T	2/1/2002		
Arch/Engr Contract	2/15/2002		
Construction Document Approval	4/15/2002		
Bid Opening	6/1/2002		
Award of Contracts	7/1/2002		
Construction Start	7/1/2002		
Report of Award to B/T	12/6/2002		
Completion	9/15/2002		

FUNDING INFORMATION:

HB640 Mansfield Basic Renovations	\$	160,000	\$	-
HB640 Regional Basic Renovations				
HB748 Regional Campus Line Items		53,300		
North Central Technical College		157,275		
Total	\$	370,575	\$	-

USES:

Construction	\$	305,000	\$	-
Contingency		24,400		
Design		36,600		
Univ. Administration		4,575		
Total	\$	370,575	\$	-

COMMENTS:

Mansfield Campus - Roadway and Parking Lot Resurface

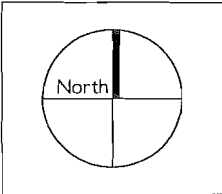
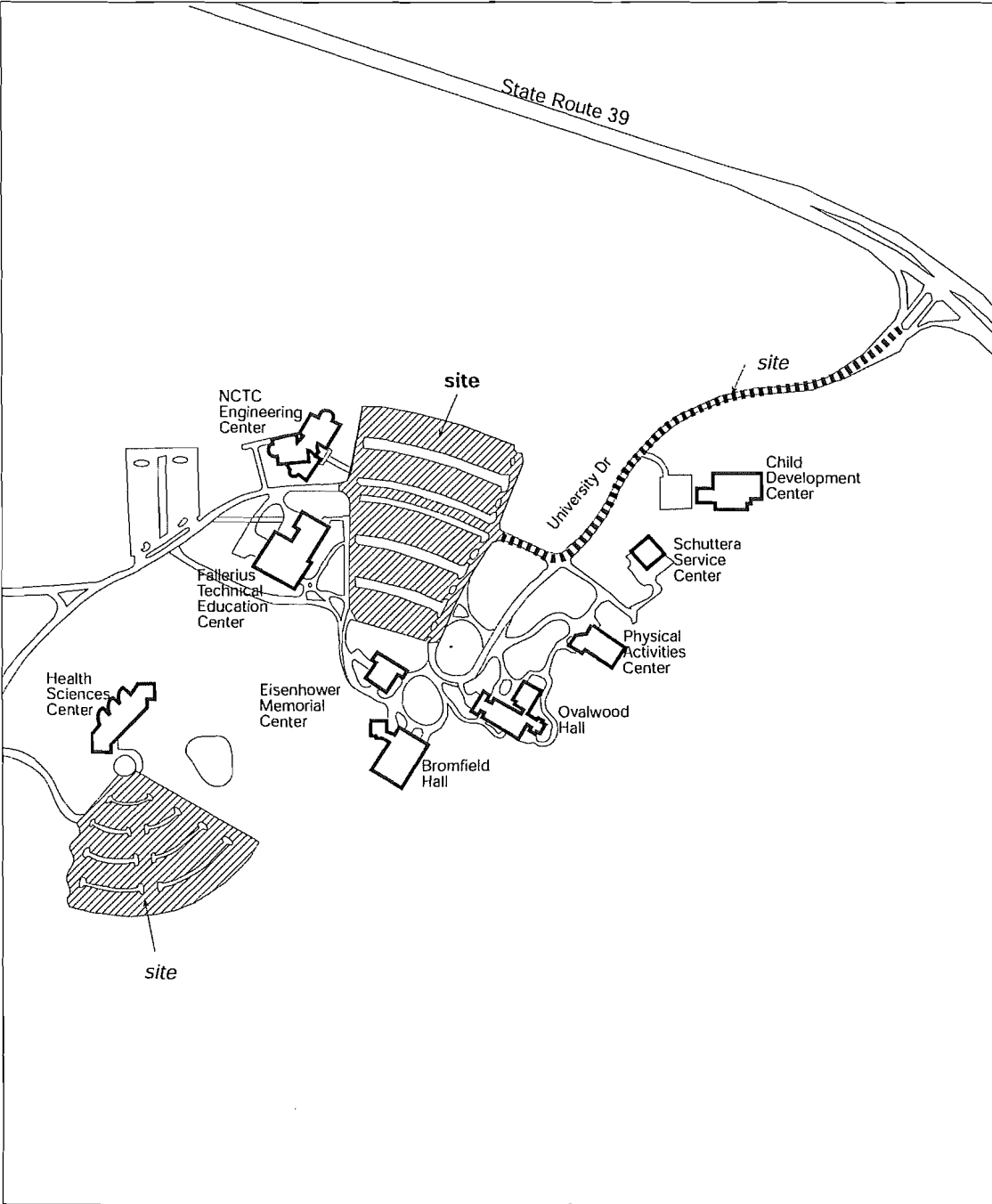

Office of Business and Finance
Office of Facilities Planning and Development

January 12, 2002

Riverwatch Tower - Suites B and C

5070-R991615

PROJECT CAPTAIN:

Ruth Miller, Facilities Planning & Development - Architecture, 292-4240

REQUESTING AGENCY:

Office of the Treasurer

PROJECT LOCATION:

0969-RIVERWATCH TOWER (SUITE 100B, 100C)

AGE:

1987

GR. SQ. FT.:

14,775

PROJECT DESCRIPTION:

Renovation of office space for the University Treasurer's staff located on the ground floor of Riverwatch Tower. Scope of work includes selective demolition, some new walls and doors, painting, carpeting, new ceilings and lighting, minor mechanical upgrades, data and electrical upgrades, office furniture, and ADA upgrades to the restrooms.

MILESTONES:

	Projected	Revised	Actual
Arch/Eng Approved B/T	2/1/2002		
Bidding Approved B/T	2/1/2002		
Arch/Engr Contract	1/10/2000	1/10/2000	1/15/2000
Schematic Design Approval	5/2/2000	6/15/2000	6/28/2000
Design Development Approval	6/1/2000	8/15/2000	7/15/2000
Construction Document Approval		11/25/2001	11/25/2001
Bid Opening	4/15/2002		
Award of Contracts	5/30/2002		
Construction Start	5/30/2002		
Completion	11/30/2002		

FUNDING INFORMATION:

General Fund-Business and Finance	\$	326,612	
Total	\$	326,612	

USES:

Construction	\$	270,953	\$	-
Contingency		27,095		
Design		24,500		
Univ. Administration		4,064		
Total	\$	326,612	\$	-

COMMENTS:

The original project scope was to renovate the space occupied by the Treasurer's Office in Riverwatch Tower at a cost of approximately \$181,000. During the design process, occupants in the adjacent space (ACUHO) moved out and their space was assigned to the Treasurer's Office as well. It was determined that this additional space should also be included in the renovation as it would permit the Treasurer's Office to move additional staff from Lincoln Tower to Riverwatch Tower.

Riverwatch Tower - Suites B and C

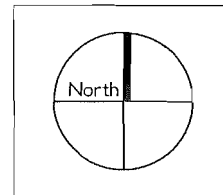
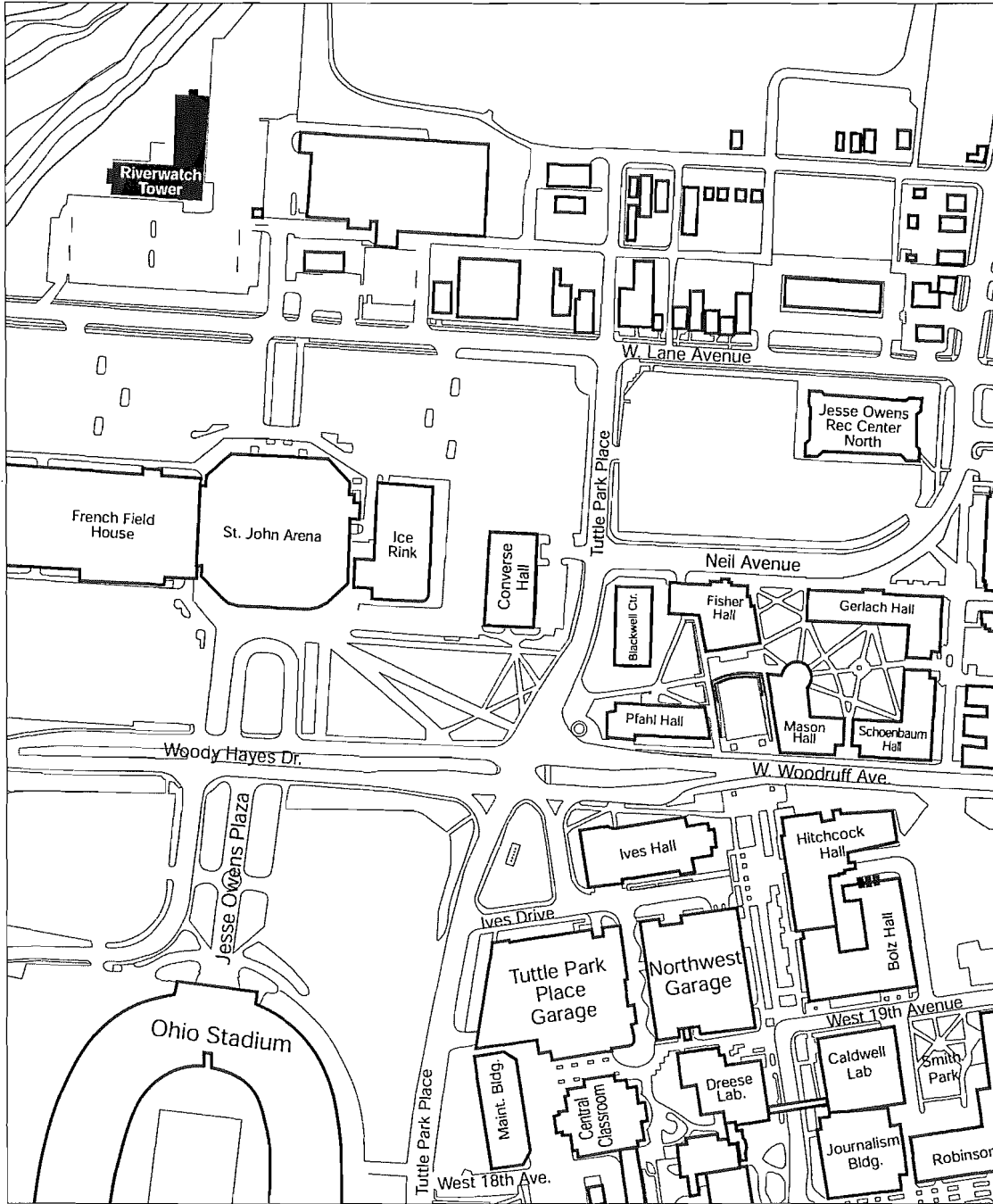

Office of Business and Finance
Office of Facilities Planning and Development

January 10, 2002

PROJECT CAPTAIN:

Jack Bargaheiser, Facilities Planning & Development - Architecture, 247-7607

REQUESTING AGENCY:

Knowlton Sch.& Engineering

PROJECT LOCATION:

0002-VIVIAN HALL, ALFRED

AGE:

1951

GR. SQ. FT:

52976

PROJECT DESCRIPTION:

Removal of selected partitions and all lab benches; addition of electrical outlets and lights as required in Vivian Hall. Basement: 1,1A, 2, 3J, 4, X8C, 11, 22, 23, 23A, 24, 25A-C, 26, 27, 28, 31; first floor: 109, 109A-B, 110, 111A, 112, 113, 114,, 11115, 116, 117, 118, 120, 121, 122, 122A-H; second floor corridor: 2008, 210, 211, 213, 214, 214A, 215, 215A--B, 216A, 217, 218.

Reference December 5, 2000 memo from Bill Shkurti to David Ashley.

MILESTONES:

	Projected	Revised	Actual
Arch/Eng Approved B/T	6/1/2001		
Bidding Approved B/T	6/1/2001		
Construction Document Approval	5/16/2001		
Award of Contracts	5/20/2001		
Construction Start	5/20/2001		
Report of Award to B/T	12/7/2001		
Completion	8/15/2001		

FUNDING INFORMATION:

Centrally Funded Capital Projects	\$ 152,500	\$	\$
Future Univ. Bond Issues	152,500		
Total	\$ 305,000	\$	\$

USES:

Asbestos	\$ 41,000	\$	\$
Construction	220,000		
Contingency	22,000		
Design	17,380		
Univ. Administr	4,620		
Total	\$ 305,000	\$	\$

COMMENTS:

Vivian Hall - Rooms 1-218

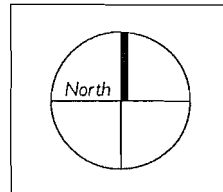
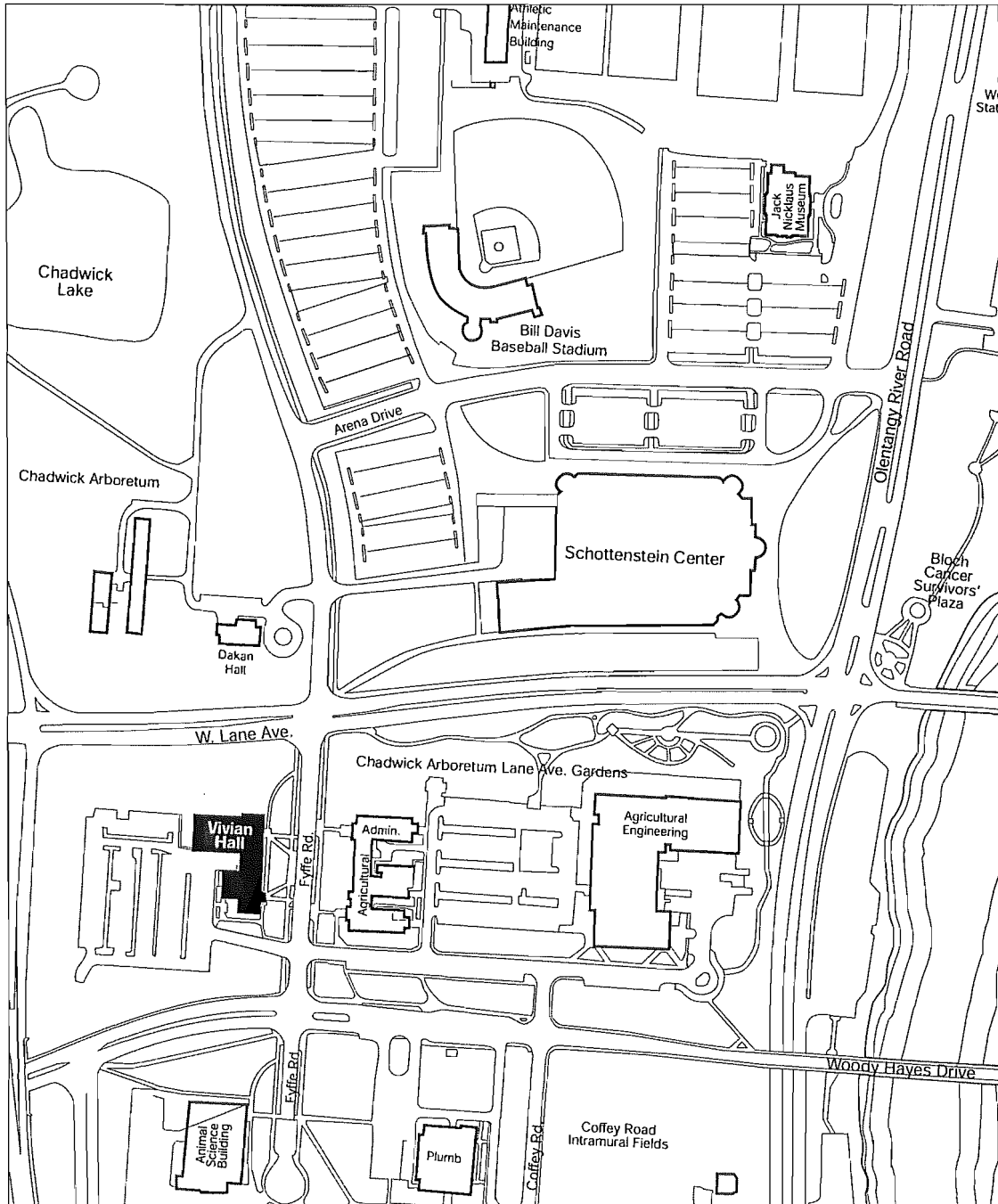

Office of Business and Finance
Office of Facilities Planning and Development

May 16, 2001

(APPENDIX XXIV)

PURCHASE OF REAL PROPERTY

CAMPUS VIEW VILLAGE APARTMENTS
929 SHARON VALLEY ROAD, NEWARK, OHIO

Location and Description

The property to be purchased is owned by Campus View Village, an Ohio non-profit corporation, and located at 929 Sharon Valley Road in Newark, Ohio. The property is adjacent to the Newark Campus. This property consists of two apartment buildings, containing a total of 42 units, and related site improvements, constructed in 1986 and in good condition, situated on approximately 4.55 acres.

Appraisals and Consideration

MAI appraisals by Koon and Associates in August 2001 and Reith Real Estate Services in September 2001 valued the property at \$2,825,000 and \$3,050,000, respectively, for an average appraised value of \$2,937,500. Campus View Village has offered to sell the property for that amount. The seller will transfer the property to the Newark Campus Development Fund which then will sell the property to the University. Student Affairs will provide funding for the purchase and all costs associated with operation of the property.

Use of the Property

Title to the property will be taken in the name of the State of Ohio for the use of The Ohio State University. The property will be used to provide University student housing that will be operated by Student Affairs. The acquisition of this property is critical for the development of student housing at the Newark Regional Campus.

Purchase of Real Property Campus View Village Apartments Newark, Ohio

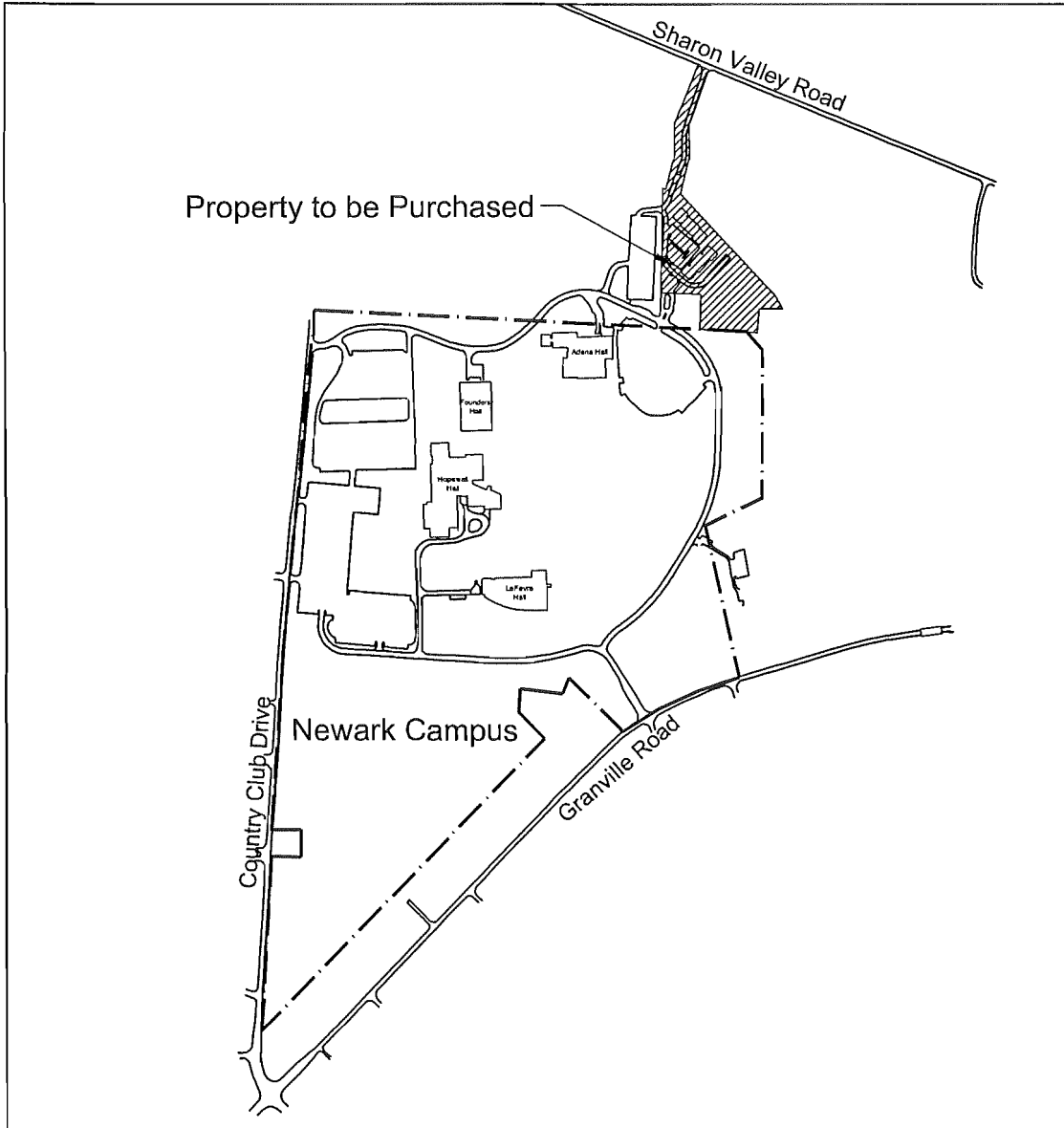

No True Scale



Map Provided by University Engineer's Office

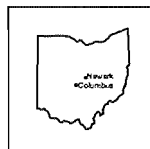

Office of Business and Finance
Office of Facilities Planning and Development
February 1, 2002



Property to be Purchased



Campus Property Line

(APPENDIX XXV)

The Ohio State University Board of Trustees
Fiscal Affairs Committee

February 1, 2002

TOPIC:

Budget v. Actual Report for FY 2000-01

CONTEXT:

This is an annual report on the differences between budgeted and actual revenues and expenditures.

Budget v. Actual was first provided to the Board four years ago.

The FY 2001 report is the first using the new general ledger. In order to provide more flexible and accurate tracking of revenues and costs the new system converted:

- 450 organizations in the old accounting system into over 3800, and
- 800 account and sub-code categories into almost 3000 new categories.

In coordination with the State of Ohio, the University is implementing several new governmental reporting standards in FY 2002 that will replace the current multi-column financial statements with a "business-type activity" format.

SUMMARY:

- The records of the University budget and accounting system are reconciled.
- There were a large number of one-time accounting adjustments and reclassifications due to the conversion to the new general ledger.
- General Fund resources were 3.1% over budget, primarily due to higher than budgeted growth in indirect cost recoveries, unrestricted endowment income, and temporary investment income. These have already been taken into account in the FY 03 budget projections. General Fund expenditures were slightly over budget, due to a combination of year-end accounting adjustments and one-time expenditures.
- Resources for earnings units were 2.6% below budget primarily due to lower than budgeted revenues for the University Hospitals System, the midyear change in the University Bookstore operation, and less activity than budgeted in other auxiliaries. Restatement of timing and classification of debt service payments resulted in actual expenses slightly higher than budgeted expenses.
- Restricted resources and expenditures exceed estimates due to an increase in grants and contracts.

ACTION REQUESTED OF FISCAL AFFAIRS COMMITTEE:

Approval of resolution.

THE OHIO STATE UNIVERSITY
COMPARISON OF BUDGET TO ACTUAL
COLUMBUS CAMPUS FOR FY 2001
(In Thousands)

	General Funds			Earnings			Restricted		
	Revised Budget	Actual	% Variance	Revised Budget	Actual	% Variance	Revised Budget	Actual	% Variance
Resources									
State Subsidy & State Appropriations	337,986	338,395	0.12%				58,775	56,498	-3.87%
Student Fees	334,452	337,507	0.91%	7,800	7,973	2.22%			
Grants, Contracts & Appropriations	47,035	57,661	22.59% (1)				342,000	417,575	22.10% (13)
Hospitals				641,548	611,538	-4.68%			
Auxiliaries				168,316	145,433	-13.60% (8)			
Other Sales & Services				47,500	64,996	36.83% (9)			
Endowment Income	3,375	5,314	57.45% (2)				32,000	12,050	-62.34% (14)
Temporary Investment Income	11,300	18,544	64.11% (3)		6,328	0.00% (10)			
Other Sources of Income	6,533	6,454	-1.21%		6,326	0.00% (11)			
Total Resources	740,681	763,875	3.13%	865,164	847,594	-2.04%	432,775	486,123	12.33%
Expenditures									
Instructional & General	659,977	686,619	4.04%	39,472	65,445	65.80% (12)	108,033	128,018	18.50%
Scholarships & Fellowships	46,821	49,277	5.25%				47,000	46,894	-0.23%
Hospitals				632,377	631,585	-0.13%	13,242	13,395	1.16%
Auxiliaries	1,412		-100.00% (4)	166,761	160,454	-3.78% (8)	7,500	11,066	47.55% (15)
Separately Budgeted Research	29,294	15,178	-48.19% (5)	10,188	10,279	0.89%	170,000	202,954	19.38%
Public Service	3,116	5,782	85.56% (6)	11,750	11,507	-2.07%	87,000	83,796	-3.68%
Total Expenditures	740,620	756,856	2.19% (7)	860,548	879,270	2.18%	432,775	486,123	12.33%

General Funds:

- (1) Indirect cost recoveries were up \$7M (15%) and there was a \$4.3M year-end audit adjustment to record residual contract funds.
- (2) Reflects increase in endowment income in previous years. Budget adjusted in FY 2002.
- (3) Earned \$2M more than budgeted; audit adjustment of \$5M for unbudgeted accrued income and a standard year-end entry to record market adjustments.
- (4) Classification issue: Actual General Funds support to the Student Unions is included in Instructional & General Expenditures.
- (5) Budget includes Research Challenge of \$9.3M while these funds may be spent in other lines including transfers to plant for research projects. Also, a negative \$4.3M audit adjustment was made to reclassify a FY00 entry.
- (6) Variance was due to a reclassification of expenditures that were previously recorded in Instructional & General. Future budgets will be adjusted.
- (7) General Funds expenses exceeded budget as a result of planned spending one-time cash reserves set aside from previous years.

Earnings:

- (8) Activity is lower across the board in all auxiliaries plus the sale of the Bookstores mid year. Expenditures are high due to debt service transfers totaling \$14.5M that belong to a previous year.
- (9) Classification issue: Includes an audit adjustment (\$8M) to temporarily recognize cash receipts which will be reclassified in FY 02. Also, a \$3M increase in OARNET'S Sales and Services due to increased sales of "band widths" to schools.
- (10) Classification issue: Actual includes investment income for earnings accounts that are included in Hospital and Auxiliary budget lines.
- (11) Classification issue: Included in Sales & Services line in the Budget.
- (12) The budget has been conservative compared to activity and has been adjusted for FY 2002. Actual also includes \$9M in transfers which are not included in the budget.

Restricted: Budget reflects prior year spending trends.

- (13) Primarily due to an 18% increase in sponsored program activity.
- (14) Income is equal to expenditures which are down partly due to Development being paid from Endowment income (\$8.5M) and other reclassifications to the Grants and Contracts line.
- (15) The budget includes Athletics grants-in-aid only while Actual includes bowl expenses which vary widely depending on the bowl.

This is the first time we have done Budget versus Actual with the new GL. There may be variances due to the GL conversion and a new way of functionally classifying expenses.

THE OHIO STATE UNIVERSITY
OFFICIAL PROCEEDINGS OF THE
ONE THOUSAND THREE HUNDRED AND EIGHTIETH MEETING
OF THE BOARD OF TRUSTEES

Columbus, Ohio, March 1, 2002

The Board of Trustees met at its regular monthly meeting on Friday, March 1, 2002, at The Ohio State University Longaberger Alumni House, Columbus, Ohio, pursuant to adjournment.

**

**

**

Minutes of the last meeting were approved.

**

**

**

March 1, 2002 meeting, Board of Trustees

The Chairman, Mr. Brennan, called the meeting of the Board of Trustees to order on March 1, 2002, at 10:40 a.m. He requested the Secretary to call the roll.

Present: David L. Brennan, Chairman, James F. Patterson, Zuheir Sofia, Tami Longaberger, Daniel M. Slane, Robert M. Duncan, Karen L. Hendricks, Dimon R. McFerson, Jo Ann Davidson, Kevin R. Filiatraut, and Joseph A. Shultz.

--0--

PRESIDENT'S REPORT

President William E. Kirwan:

Members of the Board of Trustees, one month ago my colleagues and I proposed for your consideration a resource strategy that would enable us to advance our Academic Plan despite the substantial cuts in our state budget. The largest source of funds in this strategy was a \$35 million budget reduction and reprogramming effort now underway. Ed Ray and Bill Shkurti will report on the status of this effort in just a moment.

As another part of our strategy, we proposed a significant additional charge – \$1,200 – for new students on top of the nine percent increase already planned and announced for continuing students. The purpose of this additional fee was twofold: first, it would help us address our immediate resource needs. But perhaps even more important for the longer term, it would enable us to reposition Ohio State's tuition to a level more consistent with our mission, with our role as the state's flagship university, and with our aspirations for Ohio State to become one of the nation's finest public teaching and research universities.

We ended our discussion last month with the hope and expectation that an agreement on tuition levels could be reached with Governor Taft, who had expressed concern about tuition proposals by Ohio's public colleges and universities. Earlier this week, the Inter-University Council and Governor Taft did announce an agreement on a set of tuition principles at IUC schools for the next academic year. An agreement, I add, in which Ohio State played a major role.

Consistent with the principles of this agreement, we have amended our proposal to phase in the extra charge for new students over two or three years, rather than implement this charge all in one year. Thus, under the proposal that is before you today, tuition for current students would continue to rise by nine percent. New students, entering school beginning next summer would pay \$5,217 plus an additional \$474 for a total of \$5,691, or an increase of 18.9 percent. That compares with the \$1,200 -- 35 percent increase -- proposed to you on February 1.

Regarding future years, we remain committed to our original plan since our budgetary problems and the need to reposition our tuition remain. Next year, after taking into account the new level of state support, we will propose an additional charge for students entering in Fiscal Year 2004 that will be on top of tuition charged for continuing students. We intend to continue this strategy for the next several years.

Let me make a couple of points regarding where we have come out on this matter. First, I want to thank Governor Taft and the legislative leaders for explicitly recognizing that Ohio State needs special consideration regarding its tuition level. The agreement I referred to grants Ohio State additional flexibility beyond that extended to the other IUC institutions. I also want to thank our state leaders for endorsing our two-tiered approach with regard to our tuition strategy.

PRESIDENT'S REPORT (contd)

President Kirwan: (contd)

Second, we understand the Governor's concern that many Ohio families face difficulties in today's tough fiscal climate and believe phasing in these new student charges over several years will be helpful to them.

Third, I emphasize once more that we remain committed to preserving access and affordability by increasing grants and scholarships to assure that no admitted student is turned away from Ohio State for financial reasons.

This amended proposal means that for Fiscal Year 2003, we will face a substantial cash shortfall of approximately \$6 million. We will address that shortfall through a combination of additional selective spending reductions, additional revenue from other sources, redirection of existing resources, and careful cash flow management.

Bill and Ed will provide you with a complete analysis of how we intend to address this resource shortfall in just a moment.

I should also add a caveat. The tuition levels we have discussed presume no additional state budget cuts this year or next. With this assumption and further belt tightening, the tuition increases we propose will allow us to meet our commitment for faculty and staff compensation next year, enhance our undergraduate programs, and support other selected priorities in the Academic Plan. Any further reduction in state support would prevent us from moving forward with these initiatives and would require us to reconsider our entire tuition strategy.

In sum, implementing this strategy over two or three years rather than one year as we had originally proposed, will allow us to make continued progress toward academic excellence, although not as quickly as we would like and not without additional and painful budget trimming.

There is one final comment I would like to make on the tuition issue. Our students and especially the Undergraduate Student Government, under the outstanding leadership of its president, Eddie Pauline, have been enormously supportive of our efforts. They have worked very effectively, both on campus and down in the Statehouse, explaining and building support for our plans.

Fortunately, not every activity at the University this past month has revolved around questions about tuition and funding, although there have been many days when I thought that was all there was in life. In fact, there were a number of great things happening at Ohio State over the past month, and I'd like to tell you about just a few of them.

For instance, a new report from the Higher Education and National Affairs American Council on Education ranked Ohio State among the top five universities in the nation for granting Ph.D.'s to African Americans. We also rank in the top 20 for granting doctoral degrees to American Indians and Alaskan natives.

I'd like to mention two impressive examples of progress towards the goals of the Academic Plan. A report in today's issue of the *Chronicle of Higher Education* ranks Ohio State twentieth among all universities, public and private, in terms of the number of National Merit Scholars in this past fall's freshman classes. I emphasize that is public and private, so it includes all of the Ivy League schools as well.

PRESIDENT'S REPORT (contd)

President Kirwan: (contd)

Also consistent with our aspirations for academic excellence, we are bringing to the Board today a request for a major faculty appointment. Fred Sanfilippo and his colleagues have succeeded in recruiting another world-class faculty member, Dr. Jay L. Zweier. Dr. Zweier is the chief of cardiology research at Johns Hopkins University, the nation's number one ranked medical school. He has been recruited to head Ohio State's heart and lung research programs. With the Board's approval, he will be named director of the Davis Heart and Lung Research Institute, which unites the work of scientists from a variety of disciplines across the University.

This is a major achievement for our heart and lung program and makes a powerful statement about Ohio State's commitment and determination to develop and foster nationally renowned teaching and research programs. The future of our medical education and research programs is of utmost importance, and Dr. Zweier brings to Ohio State highly-acclaimed talent and leadership that will allow the program's momentum to accelerate. We are very pleased to welcome Dr. Zweier to The Ohio State University.

One of the foremost international events this past month was the Winter Olympics, and Ohio State was very well represented in Salt Lake City. Three Buckeyes performed exceptionally well in the Olympics – two on the snow and ice, and one behind the scenes.

One of our two star athletes at the Olympics was Lea Ann Parsley, an Ohio State Ph.D. candidate in community health nursing and a firefighter in Plain Township in Granville, who won the Olympic silver medal in skeleton. It was truly incredible watching her fly down the ice, headfirst, on that small sled at more than 80 miles an hour. This entire community was right with her all the way. Lea Ann could not be here today, because she is now in Lake Placid training for the national championships.

However, our two other Buckeye Olympians are here this morning and it is my great pleasure to introduce them to the Board. Our behind-the-scenes Olympian was University Police Lieutenant Al Washer. He was one of only 500 officers nationwide and only seven from Ohio to be asked to join the Utah Olympic Police Safety Command. Due in large part to their efforts the Olympics were safe, secure, and smooth for the athletes and the spectators.

Our other Olympic athlete is Emma Laaksonen. Emma is a sophomore business major and a defenseman on the tenth-ranked Ohio State women's hockey team. Emma was a co-captain of the women's hockey team of her native country Finland, and they finished fourth in the Olympics. At Ohio State, Emma was named a scholar-athlete last year, and in February she and teammate Jeni Creary were named as two of the 10 candidates nationwide for the Patty Katzmaier Memorial Award, which is the nation's premier intercollegiate women's hockey award.

Lieutenant Washer and Emma, you and Lea Ann have made us very proud and I know you have some very special memories to treasure for the rest of your lives. On behalf of The Ohio State University, I want to congratulate you on your truly exceptional accomplishments.

Also prominently featured in the national news this week and also making us very proud are two Buckeye graduates. Just days after we celebrated the 40th anniversary of John Glenn's historic space flight, Nancy Currie, Richard Linnehan, and five other astronauts launched aboard the space shuttle *Columbia*

PRESIDENT'S REPORT (contd)

President Kirwan: (contd)

on a mission to install new equipment on the Hubble telescope. Rick Linnehan earned a Doctor of Veterinary Medicine degree at Ohio State in 1985, and Lieutenant Colonel Nancy Currie is an OSU Army ROTC alumna who earned a B.A. degree in biological sciences in 1980. She is showing her Ohio State spirit by carrying with her into space Ohio State's ROTC Battalion flag.

Here on campus a number of our faculty, staff, students, and programs have also received national and local recognition this past month. Linda K. Weavers, assistant professor in the Department of Civil and Environmental Engineering and Geodetic Science, was awarded the highly prestigious Presidential – as in President Bush, not President Kirwan -- Early Career Award for Scientists and Engineers by the National Science Foundation. This is a really impressive award. It only goes to the very best young scientists and engineers in the United States. So it is a great honor for Linda.

Another major award went to Christopher Plass, a researcher in the OSU Comprehensive Cancer Center's molecular biology and cancer genetics program. The Leukemia and Lymphoma Society designated Dr. Plass as one of only 10 Society Scholars this year for his substantial contributions to cancer research. The award carries a salary support of \$100,000 a year for five years.

I'm also pleased to report that Deborah Ballam, professor of Finance, and Sherri Geldin, director of the Wexner Center for the Arts, were among the seven women selected by the YWCA as their 2002 Women of Achievement award winners. As for Ohio State students, two of our best undergraduates, David Lieberman and Ebo Taiwo, have advanced to the final round of the prestigious Truman Scholarship competition. And two more, Surya Parekh and John Nees, are finalists for the Mellon Fellowship. Quite an impressive showing.

Also, today it is with mixed emotions that I announce the retirement of Dr. Manuel Tzagournis, professor emeritus in the Department of Internal Medicine. Manny Tzagournis is an icon at the University and throughout the community. He has had a truly remarkable career at Ohio State as a world-class researcher, an inspiring teacher, and a valued University leader.

Manny formerly served as vice president for Health Sciences and dean of the College of Medicine. Under his visionary leadership, our academic Medical Center developed into a national leader known worldwide for high quality service, outstanding education, and cutting-edge research. Few people, anywhere, have done as much to advance the healthcare profession over the past 20-plus years as has Manny Tzagournis.

For the myriad of us who claim Manny as our personal physician, I am very pleased to report that despite his retirement, which becomes effective today, he will continue to teach and practice medicine.

Finally, I would like to personally and publicly send the family of Mike Moritz our most heartfelt support at this very difficult time. Mike is a true leader in our community, a great, great friend of Ohio State, and a close personal friend of many of us in this room. Our thoughts and prayers are with Mike and his family.

Mr. Chairman and members of the Board, this completes my report.

PRESIDENT'S REPORT (contd)

Mr. Brennan:

I'd like to add my own personal words of congratulations to Dr. Tzagournis. As President Kirwan mentioned, he is the personal physician to many of us here – trustees, administration, faculty, and staff, and, I'm sure, even students. One of the most remarkable things about this remarkable man is he is first, last, and always a family physician. Congratulations, Manny.

--0--

IMPACT OF BUDGET CUTS AND TUITION RECOMMENDATIONS

Provost Edward J. Ray: [Overhead Presentation]

First, I will briefly review the recommendations that we made and discussed at the February Board meeting, and many of the characteristics of that proposal will carry forward. I will also talk about what we are proposing at this meeting, the problems that presents for us to solve, and why we're not going to solve the continuing budget challenge through further cuts to the academic and support programs. Bill Shkurti will then discuss: how the funding gap will be closed and ideas that we have for dealing with that; what the implications of the proposals are that we are bringing forward to you; and how what we are recommending changes our positioning relative to other universities with regard to tuition in-state, with the Big Ten, and with the benchmark universities to which we compare ourselves. Bill will also talk about what we need to do next and then I'll briefly summarize.

You have this material in your book, but it is on the screen as well. To remind you where we were in our discussion when we left off on February 1, we made it very clear that the University recognizes it has a responsibility to serve as an engine for growth for the State of Ohio, and that we can't do that without adequate resources. We brought information to you that identified a \$73 million funding challenge for next year. Also, \$36 million of the \$73 million would be dealt with through program cuts and reallocations, and \$20 million of that \$36 million involved hard cuts in budgets: \$9 million to colleges; \$7 million to support units; and \$4 million to central investment strategic funds.

We also recommended continuing planned increases in tuition for current students that would provide \$24 million in funding, and then an additional \$11 million in funding through the new undergraduate student increase of \$1,200. We indicated at that time that we would do all we could to preserve access and affordability by providing appropriate financial aid support for students, so that no student who is qualified to be here would be barred for economic reasons. You remember we talked about setting aside \$4.4 million of the \$11 million for that purpose.

We talked about our other funding priorities, which we maintain are to provide faculty and staff with adequate compensation and to provide compensation, on average, above what the market rate proves to be going into next year. We also said that we wanted to continue to make improvements in the quality of the undergraduate experience, both inside and outside the classroom. These are key elements of our Academic Plan, and we're committed to continuing to make progress in that regard.

Even after these tuition increases that we talked about, we made it clear that this would position us comfortably in the middle of the Big Ten and our benchmark peer group. It would leave us comfortably within the other Ohio universities that have selective admissions, with respect to tuition.

IMPACT OF BUDGET CUTS AND TUITION RECOMMENDATIONS (contd)

Provost Ray: (contd)

What are we recommending now? And how does that compare and contrast with what we had recommended in February?

For all undergraduates, new and continuing, we recommend a nine percent increase in instructional and general fees beginning Summer Quarter 2002. This would amount to a \$429 increase for the year – from \$4,788 to \$5,217 for full-time undergraduates over the three-quarter academic year. For new students, we recommend an additional \$158 per quarter, or \$474 for the three-quarter academic year. That would represent an instructional fee increase above the nine percent, beginning Summer Quarter 2002, for a total of 18.9 percent.

By new students, we mean undergraduates starting at Ohio State, either on the Columbus or Regional Campuses, in Summer Quarter 2002 or later. Continuing students, means undergraduates starting at Ohio State, either on the Columbus or Regional Campuses, prior to the Summer Quarter 2002.

Current students would be grandfathered from having to pay these differential increases for a four-year period, through FY 2006. As the President mentioned, we anticipate that there will be differential rate increases for new students to be phased in over the next two or three years in order for us to achieve the goals of the Academic Plan.

I want to point out that these recommendations apply only to the Columbus Campus. Recommendations with respect to tuition increases at the Regional Campuses will be brought to you at a later meeting, after they've had time to consult with their advisory boards. Their recommendations will then be brought forward for vetting in the University.

Again, we are committed to providing increased student financial aid to assure that students who are otherwise qualified can afford access to the University. As the President pointed out, these recommendations are based on existing levels of state support. If these levels change, our recommendations may have to be modified.

Where does this leave us financially? It leaves us with an additional \$6 million that we will have to identify through a combination of additional targeted spending reductions, reallocations, and revenue increases in order to bring a balanced budget recommendation to you.

To give you a summary of where the \$6 million problem comes from -- in order to meet the program requirements for FY 2003 -- we talked about a \$73 million problem at the February Board meeting. The modification of that differential for new students from \$1,200 annually to \$474 annually, results in a corresponding reduction of \$2 million needed for financial aid. This was a point that Trustee Davidson brought up at the last meeting. If we were to have a lesser increase in a new student charge, wouldn't that moderate the extent to which we had to provide financial aid? It does, but now Ohio State needs to identify \$71 million in resources for the Columbus Campus. The table that you see, summarizes the sources of that funding that we've identified to date. Again, we had the cuts previously planned of \$20 million and previously planned reallocations and other revenue, which is the other \$16 million of the \$36 million.

Then the previously planned tuition increases of 9 percent for all undergraduate students and 5 percent for graduate and professional students. There is some misunderstanding among professional and graduate students about the base rate increase that we are proposing for them. It is five percent, as it has been for

IMPACT OF BUDGET CUTS AND TUITION RECOMMENDATIONS (contd)

Provost Ray: (contd)

a number of years. That provides \$24 million. Then the additional increase in new undergraduate student charges of \$474 a year, will generate about \$5 million. That gives us a total of \$65 million with our target of \$71 million.

What we need to turn to next is how we would propose to close the gap. I will tell you what we don't recommend and then Bill will get into what we do recommend.

If you look at this next page, what we are reminding you of is that the University and community are already dealing with very real and substantial budget challenges. The adverse impact of the \$20 million in hard cuts, and up to an additional \$16 million, will have to be reallocated or redirected in order for us to try to implement the compensation plan that we've set forth.

If you remember, we told the colleges to be prepared to cut or redirect up to five percent and that corresponds to \$18.8 million. We've asked them to indicate where the money would come from and to what extent it would involve faculty, staff, and student positions for the colleges. These are rough estimates, but looking at the plans that were submitted, we expect that to entail about 241 positions.

For the support units, the up to seven percent to be redirected or reduced from their budgets adds up to \$13.9 million and 185 possible positions. Then in central programs the ten percent adds up to \$4 million and no positions, because these were program enhancement monies that we would have made available to others. Again, if you add that up, the money to be redirected or cut is \$36.7 million.

If you look at the bottom part of that page – of those 299 positions, we believe that 248 are now vacant and 51 are, in fact, filled positions. An effort will have to be made to help relocate people in those positions either inside or outside the University. Then among non-permanent positions -- GA's, temporaries, intermittent workers, lecturers, and casuals -- we think the number there is approximately 127 positions.

So we're talking on the order of 426 positions to be eliminated – this is on head count. Most of these will be done through vacancies. I should say that we began talking about the budget challenge we were facing last spring and, as a consequence of that, most units have held back on filling positions as they became vacant through retirements and other sources of attrition. They have been banking a number of vacancy positions that could be used for budget cutting and redirection purposes.

If we look at the breakdown in terms of faculty, staff, and other, you see that 85 positions identified are faculty, 214 positions are staff, and 127 positions are "other." Again, we think that given the challenge that we've given to the colleges and support units, and to reduce central investments, that we would much prefer to look in other directions before going back to those units for additional cuts to deal with the \$6 million gap.

I'll now turn to Bill to talk about what some of the other ideas are that we have and are working on.

Mr. William J. Shkurti:

Thank you, Ed. As Ed mentioned, we have a \$6 million gap to close for FY 2003. What you have here are some of the things we are thinking about.

IMPACT OF BUDGET CUTS AND TUITION RECOMMENDATIONS (contd)

Mr. Shkurti: (contd)

One of the first items I talked about with the Fiscal Affairs Committee earlier this morning is that Winter Quarter enrollments are up over projections. That would yield another \$1 million in income next year and we think that is a good number to bet on. The problem is that is only a temporary help in a sense. We have that additional money because we have more students, but if we have more students we have to teach more students and provide them services. Although I'd rather be in a situation where our enrollment is going up than down, counting that money to solve our current budget problem needs to be addressed in the long run, and we'll get back to that in a minute.

The next item is to implement the tuition increase Summer Quarter 2002. If you remember, we had actually talked about doing that last month. Last month our budget model was based on a Fall Quarter increase, so the money is still real and it does count, it just means we get it a little sooner.

Next is the non-resident surcharge. These students would pay everything the resident students pays, plus a surcharge of \$8,000. In the base budget model that we showed you in February, it also assumed that those undergraduates from out-of-state would pay everything the in-state students paid, in terms of increasing tuition, and would pay a five percent increase in their out-of-state surcharge. What this says is we are going to add another 2.5 percent on top of that.

Again, as a state institution, our first loyalty is to the sons and daughters of the taxpayers of Ohio. That is a very important part of our enrollment. I would remind you that these out-of-state students enrich the University in a number of ways. First, out-of-state students are very good students or we wouldn't admit them. They help provide a student body that is very well prepared. Second, it is also a way we help meet our diversity goals. Ohio students are exposed to a wide variety of people and they are more comfortable with what a diverse environment they will face as they leave the University. Third, these students help us in a financial sense because we don't receive any state instructional support for out-of-state students. When the state cuts instructional support, it doesn't affect this income source. We want to be careful we don't price ourselves out of the market for our non-resident students. At the same time, we want to recognize that we are a state institution. We think we have the right balance, but we want to be careful.

The next item is something we have been talking about for some time and has not become an issue until recently. We have students enrolled on the Regional Campuses and who take courses on the Columbus Campus. In the past when they did that, we just let it happen because we are all part of the same family. But as the number of Regional Campus students that take courses on the Columbus Campus increases, we think it's only fair for the Columbus Campus to receive those earnings. The students do generate instructional subsidy from the State of Ohio and tuition on the Regional Campuses. So we will charge back to the Regional Campuses for those students who take courses here. The students will not pay an additional amount, this is simply a transfer within the University and the Regional Campuses have been told this is coming.

The final item is to redirect more of our unrestricted gift money to general fund scholarships and I went into more detail on this in the Committee meeting this morning. As a result of the conversion of our accounting system, we are able to better track different accounts and sources that come into the University. We have found that we have a little more unrestricted gift money that we can spend and have been spending. We will redirect this money to general fund

IMPACT OF BUDGET CUTS AND TUITION RECOMMENDATIONS (contd)

Mr. Shkurti: (contd)

scholarships, which will take a little more pressure off the general fund, and allow us to meet our scholarship commitments. We think there is \$1 million in there. So that is \$3.6 million.

You may wonder about the "Still To Be Determined." We do have a number of ideas as to where that money should come from, but we have not had the opportunity to thoroughly vet internally and do our homework on some of these other options. We are convinced that we'll be able to do that and we will report to the Board in subsequent months how we intend to do that.

I would note the disclaimer at the bottom – these numbers are preliminary and subject to change as we refine them. We are confident that we will present, as required by state law, a balanced budget for FY 2003. By the time we ask you to vote on the budget, we will have all of these numbers nailed down.

The next page shows the implications of the recommendations we are making today. As President Kirwan and Provost Ray emphasized, the progress on our academic goals will be maintained, but at a slower pace than we had originally planned in December 2000 or in the February 1, 2002 proposal. But we will get there.

This means the compensation and student financial aid goals will still be accomplished. We will not make additional cuts to academic programs, but it means the rest of the budget is really going to get squeezed. We will have a balanced budget, but it will not be a pretty picture. It will not be painless, but we will get where we need to go.

These recommendations also mean that the contribution to the \$71 million problem from tuition increases is significant -- \$30 million -- but it is less than half of the contribution. I know there is a feeling on the part of some that the University always passes on its problems to the students without really doing anything to itself. But this shows that more than half of the solution of this problem will come internally, either from cuts or redirection of other resources. As the President and Provost have said, the access for academically-qualified students will be maintained through student financial aid and the students will benefit directly as a result. We think we'll still be a unique combination of excellence and affordability.

As the President mentioned, achieving these goals is dependent upon maintaining state support at its existing levels in FY 2002 and FY 2003. There is not a delicate way to say this, but if there are additional cuts, it means all bets are off. We'll have to go back to the drawing board. We certainly hope that doesn't happen, but nobody can guarantee it.

It also means that we do have significant resource gaps that need to be addressed in FY 2004 and beyond. As the President and Provost have mentioned, we need to continue to phase in differential tuition until we are able to achieve our academic goals and until tuition is at a point that is reflective of our unique academic mission.

One of the implications is that OSU will continue to remain affordable. These charts show our tuition compared to where we project. It shows conservatively where tuition will be for resident undergraduates in: the Big Ten; our benchmark institutions, which include the Big Ten and some others; and other selective admission institutions in Ohio. Before the budget cuts started we were in the

IMPACT OF BUDGET CUTS AND TUITION RECOMMENDATIONS (contd)

Mr. Shkurti: (contd)

middle, and at the end of the year we will still be in the middle. I don't think anyone can argue that we are gouging anybody.

What happens next? We will ask you to vote today on the undergraduate tuition levels for the Columbus Campus, so we can tell students we are recruiting what they can expect their tuition to be for next year. At the April Board meeting, we'll discuss the compensation goals in more detail and have some preliminary thoughts on the Regional Campuses' tuition. In May, we will ask you to vote on the compensation plan; in June, we will ask you to vote on all the other tuition and fees the way we normally do; and in July, we will ask you to vote on the complete budget package, which will be a balanced budget.

I will now turn to Ed to summarize.

Provost Ray:

Let me just summarize quickly. We've said all along that a principle commitment to continue to improve the University's academic standing is critical to our students' future and the future of Ohio. We still believe that commitment is absolutely essential and that we have to adhere to that even in the current circumstances of weak state support and weakness in the state economy.

The University has taken significant steps to achieve cost efficiencies and increased revenue from other sources. We've discussed it, touched on it briefly today, and discussed it in more detail at the February meeting. Nonetheless, we have a significant challenge and a significant increase is needed in tuition for the 2003 academic year in order to preserve progress already made and to make additional progress. It is important to underscore that we intend to make additional progress, both with respect to compensation and to the quality of the learning experience inside and outside the classroom for our students.

We believe the strategy we have recommended will limit the burden imposed on current students. Financial aid funds will, in fact, be appropriately adjusted to make sure that qualified students are able to attend Ohio State. Even after these proposed increases, we will still be in the middle of the pack in terms of in-state institutions, the Big Ten, and our benchmark peer institutions.

The additional funds will be used to preserve gains already made in providing progress toward competitive market-level compensation for faculty and staff, and by continuing improvements to student life, inside and outside the classroom, which is so critical to the Academic Plan.

Again, it bears repeating, that the achievement of these goals is based on the assumption that state support will be maintained at the current levels for FY 2002, the current budget year, and for the next budget year, FY 2003. As Bill indicated, significant resource issues remain for FY 2004 and beyond, and this is going to require additional differential increases for new students in future years if we are to achieve the goals of the Academic Plan.

Finally, we believe as we've expressed on many occasions, that Ohio State University, with these changes, will continue to be a great investment for our students and for the people of Ohio.

Thank you, Mr. Chairman. We'd be happy to respond to any questions.

IMPACT OF BUDGET CUTS AND TUITION RECOMMENDATIONS (contd)

Mr. Brennan:

Any questions? Dimon --

Mr. McFerson:

A year ago, we took money out of the Rainy Day Fund. Are we restoring that in this plan this year?

Mr. Shkurti:

Good question, Mr. McFerson. The President and I had that discussion yesterday and we now have a plan to restore the money in the Rainy Day Fund. We still need to have some discussion within the University about how this will be done, because it will come from our own resources. But it would be foolish on our part to continue in this uncertain environment with a depleted Rainy Day Fund. Our Rainy Day Fund is not huge – it is down to \$5 million now, but we want to build it back up to \$10 million before the end of the year if we can. So we do have plans to restore that, although we have not done it yet.

Mr. McFerson:

Okay.

Mr. Brennan:

Any other questions? Jim --

Mr. Patterson:

At our last meeting, the administration recommended the nine percent and the \$1,200 increase to come up with the \$73 million figure that we were trying to approach. A portion of that was to offset financial need from the tuition increase. If I recall your comments, we in fact did not use as much of that set aside as we had planned. With the annual increase being \$474, instead of the \$1,200, you figured that we were going to be at a \$6 million differential. Does that take into account the financial aid set aside in the \$6 million? Or might we make up that \$2.4 million?

Provost Ray:

It does to the extent that we lowered the total figure in terms of the dollars we need from \$73 million to \$71 million, as a direct result of that reduction from the \$1,200 charge to new students to \$474. We think that will reduce the money we need to set aside for student financial aid to ensure access by \$2 million. So we've reduced our estimate of financial aid need by \$2 million, in conjunction with that moving back on the additional charge for new students.

You'll remember last year we said we had set aside a certain percentage and found that we hadn't made a claim on all of it. We'll need to be monitoring that over the course of next year to make sure that first and foremost we have the resources there. We said we needed to guarantee access, but to the extent that resources can be released from that for other purposes. Certainly they'll need to be redirected, but we've already anticipated at least a \$2 million reduction in financial aid needs.

IMPACT OF BUDGET CUTS AND TUITION RECOMMENDATIONS (contd)

Mr. Brennan:

Another way of saying that is that you have an \$8 million shortfall, of which \$2 million is being made up by not raising the financial aid.

Provost Ray:

That is another way of looking at it. It is \$2 million we didn't add to our cost by going up higher.

Mr. Shkurti:

Mr. Chairman, I want to make this point, because I think it is extremely important. I hope none of the members of the media here report that we are cutting financial aid, because we are not. We are reducing financial aid proportionally to the need as a result of reducing tuition.

Provost Ray:

We are reducing the increase in financial aid that we're going to make available, because we don't need to augment it quite as much.

Mr. Brennan:

Recognizing the media always fully reports everything we say -- our financial aid is very substantial now is it not, Bill?

Mr. Shkurti:

That is correct. For example, built into these numbers is an assumption for the nine percent and that we will channel 20 percent of that to increase student financial aid. Then for the differential for new students, we will channel 40 percent of that to student financial aid. That is very generous.

Mr. Brennan:

Of all the tuition that we raise, a very substantial percentage -- 20 or 25 percent -- currently goes for financial aid. Does it not?

Mr. Shkurti:

That is correct.

Provost Ray:

Yes, it does. The figures we talked about in earlier conversations is that we provide \$32 million in financial aid. The original proposal would have taken that to \$39 million, and now we are talking about \$37 million. So we are talking about real growth in financial aid.

Mr. Brennan:

Good. I think those are useful numbers to have emphasized. Kevin --

Mr. Filiatraut:

We heard earlier in the Student and Educational Affairs Committee about the effect this will have on the student experience at Ohio State. I'm curious about

IMPACT OF BUDGET CUTS AND TUITION RECOMMENDATIONS (contd)

Mr. Filiatraut: (contd)

graduate assistants. Provost Ray, you explained that the way the budget restructuring is planned, that when a graduate assistant's position is cut, the college would not cover the person's fee authorization at that point. We saw on the overhead that there are 127 GA's, temps, and intermittent positions that have been or will be cut. How many GA's do you think this will happen to where they will now have to cover their own fee authorization?

Provost Ray:

These things really come in a couple of ways. We don't give fee authorizations or GA appointments to students who aren't either on a fellowship, have earned it through merit, or who are providing some service to the department. So my expectation is that GA reductions are actually going to be small, because these people are involved in recitation classes, some classroom instruction, or in administrative help or working on research projects.

Reducing GA appointments not only means that you lose the effort that they are providing in exchange for the fee authorization, but to the extent that it involves new student GA appointments or the loss of continuing students then, in fact, the tuition itself is lost anyway and the subsidy for those students would be lost as well.

I think there are built-in incentives for the programs themselves to be protective of GA appointments. I can assure the Board that I've received the plans from all of the colleges. I will be talking to deans in areas where they've indicated there might be a number of GA appointment eliminations, to make sure that they are being attentive to our need to protect our doctoral programs and support our graduate students. So we will have some pointed conversations.

Mr. Shultz:

Dr. Ray, you spoke before about the faculty compensation that we'll get from the additional revenues from tuition increases. Can you explain what other increases or benefits there will be to the undergraduate student experience from these tuition increases?

Provost Ray:

Joe, the faculty and staff compensation increases aren't going to come from the tuition increases. You remember we talked about the college and support area plans, and that \$20 million of the \$36 million raised through those plans will go to meet the budget reduction. The other \$16 million is about redirecting resources to help with that compensation target. So a lot of the compensation target that we're trying to meet is coming through our own redirected or reallocated resources, not through additional tuition charges on our students.

In terms of the things that we anticipate doing to help the student experience are the things that we talked about last year that we want to continue. We want to increase the number and the quality and preparation of academic advisors and counselors that we hire. We want to provide money to programs on a targeted basis to hire faculty in high demand areas, so that we can minimize the number of closeouts within majors. We will target money for closeouts and bottleneck courses that are critical for students to get from one part of their curriculum to the next.

IMPACT OF BUDGET CUTS AND TUITION RECOMMENDATIONS (contd)

Provost Ray: (contd)

We will use monies in very targeted ways to make sure that on the learning side we do everything we can to expedite time to graduation for students. On the support side, we are having very focused discussions about which student services and support activities we have to make sure we preserve and enhance. As I said, academic advising and counseling are two examples of it, but there are a number of other things as well that we will be looking into.

Mr. Brennan:

Any other questions?

(See Appendix XXVI for background information, page 883.)

FY 2002-2003 TUITION INCREASE

Resolution No. 2002-84

Synopsis: Instructional and General fees for undergraduate students enrolled at the Columbus Campus for Fiscal Year 2002-2003 are proposed.

WHEREAS the Board of Trustees of The Ohio State University supports the tuition strategy and recommendations presented at their February 1, 2002, meeting as critical to providing the resources necessary for the University to implement the Academic Plan and meet the needs of Ohio State University students; and

WHEREAS in recognition of the concerns raised about the economic difficulty many Ohio families now face, the Board supports modification of those recommendations to phase in the additional fees for new entering students at the Columbus Campus over the next two or three years; and

WHEREAS the Board anticipates it will be necessary to charge new entering students additional fees beyond those charged for continuing students for each of the next two or three years until the tuition plan is fully implemented; and

WHEREAS the tuition rates to be adopted are specifically based on the current level of State support and could be modified if State support for higher education is either increased or decreased; and

WHEREAS consultations continue to take place with regard to professional college, regional campus and nonresident fees and those fees will be determined as a part of the regular FY 2002-03 budget process:

NOW THEREFORE

BE IT RESOLVED, That Instructional and General Fees for all undergraduates enrolled at the Columbus Campus be increased by 9.0% (\$143 per quarter) for Fiscal Year 2002-03, beginning Summer Quarter 2002; and

BE IT FURTHER RESOLVED, That Instructional and General Fees for all new undergraduates enrolled at the Columbus Campus be increased by an additional \$158 per quarter for Fiscal Year 2002-03, beginning Summer Quarter 2002.

Upon motion of Ms. Hendricks, seconded by Judge Duncan, the Board of Trustees adopted the foregoing resolution by unanimous roll call vote, cast by Messrs. Brennan, Patterson, Sofia, Slane, McFerson, and Judge Duncan, Meses. Longaberger, Hendricks, and Davidson.

INTER-PROFESSIONAL STUDENT GOVERNMENT REPORT

Mr. Todd Armen:

Good morning. I would like to thank you for the opportunity to address the Board this morning. I will keep my remarks brief, so you can have an opportunity to ask any questions of the professional students that you might have.

First, the Inter-Professional Council has been working to further integrate professional students into University life by thinking outside of the box, with new approaches to doing this and ways we can change the system and not just keep working within the system. We have also been working with Vice Provost Anderson to bring leadership from the six colleges together to see if there aren't ways that these colleges can work together to improve the academic experience for their students.

Also, I'd like to address how IPC has used the money from the Coca-Cola funds that we were granted a little over a year ago. This current year, we have used \$6,000 of the \$7,000 on the professional development fund. This fund gives students grants for a number of projects including: traveling abroad to do clinical service work; attend national conferences; and deliver papers and presentations at those conferences. The money was even used for one student to represent Ohio State in the Boston Marathon.

We have used \$1,000 this year to support diversity programming. This week was our Diversity Week, and we had minority health and legal issue posters put up all over the six colleges. It will culminate tonight with an event featuring music and food from around the world that will be attended by our students.

Another \$1,000 was used to support service work in order to increase service opportunities for professional students. This included monthly events with Columbus Big Brothers and Big Sisters. We have actually had more students interested in participating in this service opportunity than they had space to accommodate us.

We will also be working with "Christmas in April," and helping to renovate the Dowd School for Homeless Children. Also as a professional student body, we are trying to become one of the largest fundraisers for the Race for the Cure.

We are excited to be working with Kevin Filiatraut and Greg Lestini on creating a Weinland Park Community Center, to increase clinical service learning for professional students. With that project we are looking at the community and seeing what services they need, what services are already in place, and how we can fulfill those needs and work off those services already in place. We are also looking for ways students would receive academic credit for participating in that program and looking for funding avenues.

Finally, we are looking towards the tuition increases this year in a new light. In view of the funding cuts from the state, we are supporting increases that the deans of the six professional schools are proposing. However, we are asking in doing so that they make public to the professional students how that money will be used so we can justify that.

I will be happy to answer any questions you might have for professional students and what your concerns are that we might be thinking about?

Mr. Brennan:

Any questions? Kevin --

INTER-PROFESSIONAL STUDENT GOVERNMENT REPORT (contd)

Mr. Filiatraut:

I asked you this in the Committee meeting earlier, but I'd like for you to reiterate this for the full Board. Today we saw a two-tiered approach to undergraduate tuition. Do you think professional students have been talking about that or considering that at all? If so, do they like it or dislike it?

Mr. Armen:

The two-tiered approach for professional students has not really been discussed. Most professional students realize that Ohio State is currently a bargain in most of their programs. To go elsewhere, they would pay often times \$10,000 - \$15,000 more per academic year. They have been supportive of the two-tiered approach for undergraduate students. Especially since most of our students did attend Ohio State as undergraduates, they realize that these changes are necessary to improve the academic experience.

Affecting any one program trickles down across all academic programs, be it professional, graduate, or undergraduate. But as far as a two-tiered approach for professional students, most professional students realize that they get large increases every year and aren't as concerned with the increase because they live off loans. However, having large debt is a problem. They realize that the value of their degree upon graduation is very important and want their academic programs to be as good as possible. Professional students accept these increases as long as they know how they will be used.

Ms. Hendricks:

Are there guidelines established on how the Coca-Cola money should be spent? Do students apply for that money? Or do you go out and seek places to spend that money?

Mr. Armen:

As far as the endowment money that the student governments have, we were given some brief guidelines when we received the money and some of the money was used to enhance academic experience through our professional development fund. We have to give yearly reports on how we are using that money, but it is really up to the student governments to decide where that money should be spent.

As far as our professional development funding, we have an application process. That is our biggest chunk -- \$7,000 out of the \$9,000, we get every year from that endowment. There are two dates by which students have to apply, and they have to submit a two to three-page application on the project that they want to do -- whether it be traveling abroad or to a conference or bringing in a speaker to campus. We really get a very broad range of requests for that money. We typically fund anywhere from \$100 - \$300 per application. You can see that to get to \$7,000, there are a lot of students that we are touching with that money.

Mr. Brennan:

Any further questions? Thank you very much, Todd.

--0--

EXECUTIVE SESSION

Chairman Brennan:

At this time, I will entertain a motion to go into Executive Session to consider a Personnel Action that is confidential under the *Medical Staff Bylaws*.

Upon motion of Mrs. Davidson, seconded by Mr. McFerson, the Board of Trustees recessed into Executive Session by unanimous roll call vote, cast by Messrs. Brennan, Patterson, Sofia, Slane, McFerson, and Judge Duncan, Mses. Longaberger, Hendricks, and Davidson. [Judge Duncan did not participate in the Executive Session.]

--0--

Mr. Brennan:

The meeting of the Board of Trustees will now reconvene.

--0--

CONSENT AGENDA

President William E. Kirwan:

We have fifteen resolutions on the Consent Agenda today and I would like to ask that #10 be considered in a separate motion. Unless there are any objections, I would like to recommend the following resolutions to the Board:

UNIVERSITY HOSPITALS BOARD APPOINTMENTS

Resolution No. 2002-85

Synopsis: Approval of appointments of University Hospitals Board members is proposed.

WHEREAS the Board of Trustees on November 30, 1979, approved the establishment of a University Hospitals Board; and

WHEREAS the membership of the Hospitals Board was approved on April 4, 1980, and has been subsequently amended; and

WHEREAS that paragraph (D) of Hospitals Board bylaw 3335-93-01 be waived, to allow for the appointment of a citizen member beyond the stated terms; and

WHEREAS there are two citizen members whose terms have expired and three vacant citizen member positions on the University Hospitals Board:

NOW THEREFORE

BE IT RESOLVED, That the following individuals be appointed as citizen members of the University Hospitals Board, effective April 2002 to April 2005:

John F. Havens
Timothy O'Dell
Nancy Petro
Ann I. Wolfe

AMENDMENTS TO THE RULES OF THE UNIVERSITY FACULTY

Resolution No. 2002-86

Synopsis: Approval of the following amendments to the *Rules of the University Faculty* are recommended.

WHEREAS the University Senate pursuant to rule 3335-1-09 of the Administrative Code is authorized to recommend through the President to the Board of Trustees the adoption of amendments to the *Rules of the University Faculty* as approved by the University Senate; and

WHEREAS the proposed changes in the *Rules of the University Faculty* were approved by the University Senate on February 14, 2002:

Amended Rules

3335-5-19 Faculty.

As used in these rules the term "faculty" shall include persons appointed by the board of trustees with regular, regular clinical, auxiliary, and emeritus faculty titles on full- or part-time appointments, with or without salary.

(A) through (C) unchanged.

(D) "Emeritus faculty": ~~persons who have served the university continuously as regular or regular clinical faculty for at least ten consecutive years~~ who, upon retirement, were recommended by the chair, the dean and the executive vice president and provost for emeritus status. Emeritus faculty may not vote at any level of governance and may not participate in promotion and tenure matters but may have such other privileges as individual academic units or the office of human resources may provide. (B/T 4/4/97, B/T 12/4/98, 4/6/99, B/T 3/1/2002)

3335-9-14 Time of registration and payment of fees; penalties.

(A) and (B) unchanged.

(C) ~~All fees, including penalties, must be paid on or before the fifteenth day after classes begin each quarter, semester, or session. Individual exceptions to this provision may be made only upon the approval of the executive vice president and provost or designee.~~ The university registrar, as the designee of the executive vice president and provost, reserves the right to refuse registration if fees are not paid by the date on which they are due. Individual exceptions to this provision may be made only upon the approval of the executive vice president and provost or designee. (B/T 4/4/97, B/T 12/4/98, B/T 12/6/2001, B/T 3/1/2002)

3335-9-18 Return of fees.*

(A) Fees (except for the application and acceptance fees) are returnable in part if a student withdraws from the university for any cause other than at the request of the university and if such withdrawal is made within the period of ~~time specified in paragraphs (B), (C), and (D) of this rule~~ established by the executive vice president and provost in cooperation with the appropriate offices, and published by the office of the university registrar. The application fee and the acceptance fee are not returnable irrespective of the reason for withdrawal.

Students dismissed from the university or withdrawing at the request of the university are not entitled to any refund of fees.

AMENDMENTS TO THE *RULES OF THE UNIVERSITY FACULTY* (contd)

Amended Rules (contd)

- ~~(B)~~ Quarter or session fees will be refunded according to the following schedule:
- ~~(1)~~ From the date on which the fees were paid through the sixth day on which classes are scheduled—full fees less ten dollars.
 - ~~(2)~~ After the sixth day on which classes are scheduled through the twelfth day on which classes are scheduled—seventy-five per cent of fees paid.
 - ~~(3)~~ After the twelfth day on which classes are scheduled through the twenty-fourth day on which classes are scheduled—fifty per cent of fees paid.
 - ~~(4)~~ After the twenty-fourth day on which classes are scheduled—no refund of fees paid.
- ~~(C)~~ Semester fees will be refunded according to the following schedule:
- ~~(1)~~ From the date on which fees are paid through the sixth day on which classes are scheduled—full fees less ten dollars.
 - ~~(2)~~ After the sixth day on which classes are scheduled through the eighteenth day on which classes are scheduled—seventy-five per cent of fees paid.
 - ~~(3)~~ After the eighteenth day on which classes are scheduled through the thirty-sixth day on which classes are scheduled—fifty per cent of fees paid.
 - ~~(4)~~ After the thirty-sixth day on which classes are scheduled—no refund of fees paid.
- ~~(D)~~ Term fees will be refunded according to the following schedule:
- ~~(1)~~ From the date on which fees are paid through the sixth day on which classes are scheduled—full fees less ten dollars.
 - ~~(2)~~ After the sixth day on which classes are scheduled through the ninth day on which classes are scheduled—seventy-five per cent of the fees paid.
 - ~~(3)~~ After the ninth day on which classes are scheduled through the twelfth day on which classes are scheduled—fifty per cent of the fees paid.
 - ~~(4)~~ After the twelfth day on which classes are scheduled—no refund of fees paid.
- ~~(E)~~(B) In order to be eligible for the listed refund, the student's record and account must be free of any administrative hold (see rule 3335-9-16 of the Administrative Code). The student must present to the office of fees and deposits, within the time specified in paragraphs ~~(B)~~, ~~(C)~~, and ~~(D)~~ of this rule, written permission to withdraw, signed by the dean of the student's college and surrender the university-issued identification card.
- ~~(F)~~(C) If exceptional conditions prevent the presentation of the authorization to withdraw at the office of fees and deposits at the proper time, and if the student has not been able to attend classes during this time, the case should be referred for decision to the university registrar or designee.
- ~~(G)~~ No fees will be returned in case of withdrawal of students until thirty days have elapsed from the date of withdrawal.
- ~~(H)~~(D) If fees are paid under mistake of law or fact, they are returnable in full.

AMENDMENTS TO THE *RULES OF THE UNIVERSITY FACULTY* (contd)

Amended Rules (contd)

~~(H)~~(E) Fees are not returnable except as provided in this rule.

NOW THEREFORE

BE IT RESOLVED, That the foregoing amendments to the *Rules of the University Faculty* be adopted as recommended by the University Senate.

DISTINGUISHED SERVICE AWARDS

Resolution No. 2002-87

Synopsis: Approval of eight individuals to receive Distinguished Service Awards is proposed.

WHEREAS the President's Planning Cabinet, upon the recommendation of the Committee on Distinguished Service Awards, nominated and recommends eight individuals for approval by the Board of Trustees to receive the Distinguished Service Award at a time convenient to the University and the recipients:

Jane Fawcett-Hoover
George Hairston
Richard M. Hill
Joan R. Leitzel
Charles Lifer
Curtis J. Moody
Barbara Trueman
Richard I. Wells

WHEREAS these awards are given in recognition of distinguished service to The Ohio State University and the awards are in accordance with action taken by the Board of Trustees in 1952:

NOW THEREFORE

BE IT RESOLVED, That the Distinguished Service Awards be approved for awarding as designated above.

DEGREES AND CERTIFICATES – WINTER QUARTER COMMENCEMENT

Resolution No. 2002-88

Synopsis: Approval of Degrees and Certificates for Winter Quarter is proposed.

WHEREAS pursuant to paragraph (E) of rule 3335-1-06 of the Administrative Code, the Board has authority for the issuance of degrees and certificates; and

WHEREAS the faculties of the colleges and schools shall transmit, in accordance with rule 3335-9-29 of the Administrative Code, for approval by the Board of Trustees the names of persons who have completed degree and certificate requirements:

NOW THEREFORE

DEGREES AND CERTIFICATES – WINTER QUARTER COMMENCEMENT (contd)

BE IT RESOLVED, That the degrees and certificates be conferred on March 22, 2002, to those persons who have completed the requirements for their respective degrees and certificates and are recommended by the colleges and schools, and that the names of those persons awarded degrees and certificates be included in the minutes of this meeting.

PERSONNEL ACTIONS

Resolution No. 2002-89

BE IT RESOLVED, That the personnel actions as recorded in the Personnel Budget Records of the University since the February 1, 2002 meeting of the Board, including the following Appointments, Appointments/Reappointment of Chairpersons, Leave of Absence Without Salary, Professional Improvement Leaves, and Emeritus Titles, as detailed in the University Budget be approved; and

BE IT RESOLVED, That rules 3335-1-03 (R) and 3335-3-35 of the Administrative Code be waived, to allow for an appointment of a five-year term for Jay L. Zweier as Director of The Dorothy M. Davis Heart and Lung Research Institute; and

BE IT FURTHER RESOLVED, That the Medical Staff Appointments (The Ohio State University Medical Center and The Ohio State University Hospitals-East) approved December 13, 2001, and January 24, 2002, by The Ohio State University Hospitals Board, be ratified.

Appointments

Name: ELECTRA D. PASKETT
Titles: Professor (The Marion N. Rowley Designated Chair in Cancer Research) and Associate Director of Population Sciences
School/Center: Public Health/Comprehensive Cancer Center
Term: January 1, 2002, through December 31, 2005
Present Position: Associate Professor, Department of Public Health Sciences, Epidemiology, Wake Forest University, School of Medicine; Director, Education Program, Nationally Designated Women's Health Center of Excellence; and Program Director, Cancer Control Program, Comprehensive Cancer Center, Winston-Salem, NC

Name: JAY L. ZWEIER
Titles: Director and Professor (The John H. and Mildred C. Lumley Chair in Medicine)
Institute/Department: The Dorothy M. Davis Heart and Lung Research Institute/Internal Medicine
Term: July 1, 2002, through June 30, 2007
Present Position: Professor and Chief of Cardiology Research, Department of Medicine, Divisions of Cardiology and Pulmonary Medicine, The Johns Hopkins University School of Medicine

Appointment of Chairpersons

February 1, 2002 through June 30, 2005

Veterinary Biosciences

Michael D. Lairmore

February 14, 2002 through June 30, 2004

Anesthesiology

Michael B. Howie

PERSONNEL ACTIONS (contd)

Appointment of Chairpersons (contd)

July 1, 2002 through June 30, 2006

Psychology

Gifford Weary

Reappointment of Chairperson

July 1, 2002 through June 30, 2005

Radiology

Dimitrios G. Spigos

Leave of Absence Without Salary

CRAIGE ROBERTS, Associate Professor, Department of Linguistics, effective Autumn Quarter 2002, Winter Quarter and Spring Quarter 2003, for personal reasons.

Professional Improvement Leaves

ROBERT S. BILLINGS, Associate Professor, Department of Psychology, effective Autumn Quarter 2002, Winter Quarter and Spring Quarter 2003.

ANNE B. MCCOY, Associate Professor, Department of Chemistry, effective Winter Quarter and Spring Quarter 2003.

Professional Improvement Leaves – Cancellation

CYNTHIA B. DILLARD, Associate Professor, School of Teaching and Learning, effective Spring Quarter, Summer Quarter, and Autumn Quarter 2001.

JACQUELINE J. GARGUS, Associate Professor, Austin E. Knowlton School of Architecture, effective Autumn Quarter 2001.

Emeritus Titles

MANUEL TZAGOURNIS, Department of Internal Medicine, with the title Vice President and Dean and Professor Emeritus, effective March 1, 2002.

BERNARD J. HAMROCK, Department of Mechanical Engineering, with the title Professor Emeritus, effective April 1, 2002.

JEAN S. OPLIGER, Agricultural Technical Institute (Science and Business), with the title Associate Professor Emeritus, effective April 1, 2002.

CAROL J. BININGER, College of Nursing, with the title Assistant Professor Emeritus, effective April 1, 2002.

EDWARD L. SMITH, Ohio State University Extension, with the title Assistant Professor Emeritus, effective March 1, 2002.

Medical Staff Appointments (The Ohio State University Medical Center)

December 2001

Arthur P. Bertolino, M.D., Ph.D., Internal Medicine, Attending, 12/13/2001-06/30/2003

Udayan Y. Bhatt, M.D., Internal Medicine, PGY7 Limited, 12/13/2001-06/30/2003

Mohammed F. Edwards, M.D., Anesthesiology, Attending, 12/13/2001-06/30/2003

Chimene W. Fikkert, D.O., Pediatrics, Attending, 12/13/2001-06/30/2003

PERSONNEL ACTIONS (contd)

Medical Staff Appointments (The Ohio State University Medical Center) (contd)

December 2001 (contd)

John W. Goulart, D.O., Surgery, PGY4 Limited (rotating), 01/01/2002-01/31/2002
John E. Hohmann, M.D., Anesthesiology, Attending, 12/13/2001-06/30/2003
Ronald Lakatos, M.D., Orthopaedic Surgery, Community Affiliate Physician, 12/13/2001-06/30/2003
Terry L. Lester, M.D., Internal Medicine, Attending, 12/13/2001-06/30/2003
Joel L. Mayerson, M.D., Orthopaedic Surgery, Attending, 12/13/2001-06/30/2002
Matthew J. Morrison, M.D., Pediatrics, Attending, 12/13/2001-06/30/2002
Anand Ramachandran, M.D., Ophthalmology, Attending, 12/13/2001-06/30/2002
Dale R. Richards, D.O., Psychiatry, Courtesy, 12/13/2001-06/30/2002
Pamela S. Ro, M.D., Pediatrics, Courtesy, 12/13/2001-06/30/2002
Chittoor B. Sai-Sudhaker, M.B.B.S., Surgery, Fellowship 1st Year, 07/01/2001-06/30/2002
Namita Sood, M.D., Internal Medicine, Attending, 11/19/2001-06/30/2002
Marcia M. Starns, P.A.-C, Surgery, Licensed Healthcare Professional, 12/13/2001-06/30/2002
Thomas E. Taylor, P.A.-C, Orthopaedic Surgery, Licensed Healthcare Professional, 12/13/2001-06/30/2002
Lawrence A. Wetterau, M.D., Pediatrics, Attending, 12/13/2001-06/30/2002

Requests for Additional/Special Privileges (The Ohio State University Medical Center)

December 2001

Mark W. Arnold, M.D., Surgery, Attending, Moderate Sedation
Amer Rajab, M.D., Ph.D., Surgery, Attending, Laparoscopic and Thoracoscopic Surgical Procedures
Namita Sood, M.D., Internal Medicine, Attending, Right Heart Catheterization and Acute Vasodilator

Medical Staff Appointments (The Ohio State University Medical Center)

January 2002

Mary M. Dobyms, M.D., Psychiatry, Attending, 01/24/2002-06/30/2003
Najwa E. El Dahdah, M.D., Pediatrics, Courtesy, 01/24/2002-06/30/2003
Linda J. Fisher, C.R.N.A., Anesthesiology, Licensed Healthcare Professional, 01/24/2002-06/30/2003
Gwyn R. Londeree, M.D., Internal Medicine, Attending, 01/24/2002-06/30/2003
Kendrick D. McArthur, D.O., Surgery, PGY4 Limited (Rotating Resident), 02/01/2002-02/28/2002
Lawrence H. Mendel, D.O., Family Medicine, Community Affiliate Physician, 01/24/2002-06/30/2002

Medical Staff Appointments (The Ohio State University Hospitals East)

November 2001

Syed S. Ali, D.O., M.S., M.B.B.S., Surgery, PGY1 Limited, 11/19/2001-06/30/2003
Darrin L. Bright, M.D., Family Medicine, Active, 11/19/2001-06/30/2003
Rebecca J. Bruner, M.D., Internal Medicine, Limited, 11/19/2001-06/30/2003
Shalva V. Kakabadze, M.D., Family Medicine, Active, 11/19/2001-06/30/2003
Carolyn D. Lugannani-Guarino, M.D., Family Medicine, Active, 11/19/2001-06/30/2003
Richard F. Maier, Jr., D. O., Anesthesiology, Active, 06/08/2001-06/30/2002
Sachida N. Manocha, M.D., Anesthesiology, PGY2 Limited, 11/19/2001-06/30/2002
Steven M. Nash, M.D., Internal Medicine, Active, 11/19/2001-06/30/2002
Patrick A. Pasion, D.O., Anesthesiology, PGY2 Limited, 11/19/2001-06/30/2002
Stephen M. Pickstone, M.D., Internal Medicine, Active, 11/19/2001-06/30/2002

March 1, 2002 meeting, Board of Trustees

PERSONNEL ACTIONS (contd)

Medical Staff Appointments (The Ohio State University Hospitals East) (contd)

November 2001 (contd)

Milton I. Setnar, D.O., Internal Medicine, Courtesy, 11/19/2001-06/30/2002
Mark A. Williard, M.D., Internal Medicine, Active, 11/19/2001-06/30/2002

December 2001

Kenneth O. Cayce, M.D., Family Medicine, PGY1 Limited, 12/17/2001-06/30/2003
Mirela Crisan, M.D., Family Medicine, PGY1 Limited, 12/17/2001-06/30/2003
Joel L. Mayerson, M.D., Orthopaedic Surgery, Active, 12/17/2001-06/30/2002
Chittoor B. Sai-Sudhaker, M.B.B.S., Surgery, Limited (Fellow), 12/17/2001-06/30/2002
Paul M. Shearer, D.P.M., Podiatry, Active, 12/17/2001-06/30/2002
Marcia M. Starns, PA-C, Surgery, Allied Health, 12/17/2001-06/30/2002

Request for Change of Medical Staff Status (The Ohio State University Hospitals East)

December 2001

William F. Emlich, Jr., D.O., Internal Medicine, Courtesy to Active, 12/17/2001-06/30/2003
Joel R. Politi, M.D., Orthopaedic Surgery, Courtesy to Active, 12/17/2001-06/30/2002

Medical Staff Appointments (The Ohio State University Hospitals East)

January 2002

Robert R. Brightwell, D.O., Surgery, Active, 01/24/2002-06/30/2003
Edward T. Humbert, D.O., Orthopaedic Surgery, Active, 01/24/2002-06/30/2003
Matthew R. Karlen, M.D., Radiology, PGY2 Limited, 01/24/2002-06/30/2003
David S. Passerini, M.D., Radiology, PGY2 Limited, 01/24/2002-06/30/2002
Anna A. Petrova, M.D., Family Practice, PGY1 Limited, 01/24/2002-06/30/2002
Anand Ramachandran, M.D., Ophthalmology, Active, 01/24/2002-06/30/2002
Sushil Sethi, M.D., Surgery, Courtesy, 01/24/2002-06/30/2002
Jonathan G. Wash, D.P.M., Podiatry, Active, 01/24/2002-06/30/2002

RESOLUTIONS IN MEMORIAM

Resolution No. 2002-90

Synopsis: Approval of Resolutions in Memoriam is proposed.

RESOLVED, That the Board adopt the following Resolutions in Memoriam and that the President be requested to convey a copy to the families of the deceased.

Nan Arbuckle

The Board of Trustees of The Ohio State University expresses its sorrow upon the death on November 25, 2001, of Nan Arbuckle, Assistant Professor in the Department of English (Lima Campus).

Professor Arbuckle was born July 1, 1952, in Tennessee. She received Bachelor and Master of Arts degrees in English from Middle Tennessee State University and a Ph.D. degree from the University of Oklahoma. She taught at the University of Oklahoma before coming to The Ohio State University in 1985. Professor Arbuckle was an assistant professor in the Department of English and taught at Ohio State – Lima for 16 years.

RESOLUTIONS IN MEMORIAM (contd)

Nan Arbuckle (contd)

Professor Arbuckle was an enthusiastic and dedicated teacher who was devoted to her students and their progress, despite being physically challenged. She was afflicted with rheumatoid arthritis as a youth and had been in a wheelchair since the age of 12. Her teaching and scholarship interests focused on medieval literature, poetry, and the portrayal of the disabled in films.

Nan Arbuckle was an active member of the University community and served on numerous school, college, and University committees, including the Cultural Affairs, Honors, and Affirmative Action committees. She chaired the Regional Campus Faculty Council and served as the director of the Honors Program, the basic writing coordinator for English, and the sponsor of the *Metamorphosis* student writer's group.

On behalf of the University community, the Board of Trustees expresses to the family of Nan Arbuckle its deepest sympathy and sense of understanding of their loss. It was directed that this resolution be inscribed upon the minutes of the Board of Trustees and that a copy be tendered to her family as an expression of the Board's heartfelt sympathy.

Robert J. Fass

The Board of Trustees of The Ohio State University expresses its sorrow upon the death on January 1, 2002, of Robert J. Fass, M.D., Professor in the Departments of Internal Medicine and Molecular Virology, Immunology, and Medical Genetics, and Director of the Division of Infectious Diseases.

Dr. Fass had a distinguished career in the field of infectious diseases. He came to Ohio State in 1967 to complete his internal medicine residency training. He then did fellowship training in infectious diseases. In 1971, he received a master's degree in medical microbiology and joined the OSU medical faculty. He rose to the rank of professor in 1980. In 1987, he became the director of the Division of Infectious Diseases, where he served until his death. In 1991, Dr. Fass was awarded the endowed Samuel Saslaw Professorship in Infectious Diseases and received the Don Unverfurth Award for his academic contributions in 1996.

Dr. Fass was an internationally respected scientist and teacher whose impact on the training of hundreds of medical students, residents, post-doctoral fellows, and graduate students will persist for generations. His assessment and evaluation of complex medical problems provided a model for them to emulate. His critical thinking and broad knowledge will be missed.

Bob Fass was best known for his development of in vitro assays to test microbial susceptibility. His research spanned the field of infectious diseases from laboratory assessment of new antibiotics to clinical trials of these anti-infectives. His contributions facilitated the licensure of clindamycin and ciproflaxacin.

Dr. Fass served as the principal investigator of the OSU AIDS Clinical Trials Unit from its inception in 1987 until his death. This unit is supported by one of the largest NIH-sponsored grants to the University, provides access to new HIV treatments, and has undoubtedly made OSU a contributor to the progress made in dealing with this major health problem.

Dr. Fass wrote more than 130 peer-reviewed publications and served on the editorial board of *Antimicrobial Agents and Chemotherapy*. He was scientifically productive until his death. His most recent publication was in November 2001; another manuscript was published in February 2002.

At the time of his death, Dr. Fass was a member of many professional societies and organizations, including American College of Physicians (Fellow), American Medical Association, American Society for Microbiology, American Thoracic Society, British Society of Antimicrobial

RESOLUTIONS IN MEMORIAM (contd)

Robert J. Fass (contd)

Chemotherapy, European Society of Clinical Microbiology and Infectious Diseases, Inter-American Society for Chemotherapy, Infectious Diseases Society of America (Fellow), and Infectious Diseases Society of Ohio. Within the University, he served on and chaired numerous committees and assessment entities throughout his Ohio State career.

On behalf of the University community, the Board of Trustees expresses to the family of Dr. Robert J. Fass its deepest sympathy and sense of understanding of their loss. It was directed that this resolution be inscribed upon the minutes of the Board of Trustees and that a copy be tendered to his family as an expression of the Board's heartfelt sympathy.

Paul L. Gerstner

The Board of Trustees of The Ohio State University expresses its sorrow upon the death on January 28, 2002, of Paul L. Gerstner, Assistant Professor Emeritus in the Ohio State University Extension.

Mr. Gerstner was born August 6, 1935, in Kossuth, Ohio. He received a Bachelor of Science degree in animal science from The Ohio State University in 1957 and a Master of Science degree in animal nutrition from The Ohio State University in 1959.

Paul Gerstner began his Extension career in Ohio on July 1, 1958, as the County 4-H Agent in Preble County. On April 1, 1969, he became the agricultural agent in Preble County. He held this appointment until his retirement on March 31, 1982.

During his career with Extension he served as the Preble County Chair as well as being on numerous committees including the Beef Committee, Preble County Swine Committee of the Pork Producers Association, Pork Festival Committee, and Miami Valley Regional Planning Committee. He received the National Association of County Agricultural Agents Achievement Award, as well as serving on numerous local committees and being active in community organizations.

These contributions in providing excellent Extension educational programs during his career earned him the respect and admiration of coworkers and associates throughout the state.

On behalf of the University community, the Board of Trustees expresses to the family of Paul L. Gerstner its deepest sympathy and sense of understanding of their loss. It was directed that this resolution be inscribed upon the minutes of the Board of Trustees and that a copy be tendered to his family as an expression of the Board's heartfelt sympathy.

David S. Goldschmidt

The Board of Trustees of The Ohio State University expresses its sorrow upon the death on December 26, 2001, of David S. Goldschmidt, Clinical Assistant Professor Emeritus in the College of Optometry.

Dr. Goldschmidt graduated from The Ohio State University School of Optometry in 1936. He married Mary C. Kader on June 6, 1937, and opened an optometry practice in Circleville in 1938. He provided vision care to the Circleville community for 55 years until his retirement in 1993. He served in the United States Navy during World War II and was an active reservist for another five years.

He began teaching clinical optometry at Ohio State in 1954 and taught for 29 years until retiring at age 70, at which time he received the first assistant professor emeritus appointment ever given by the College of Optometry.

RESOLUTIONS IN MEMORIAM (contd)

David S. Goldschmidt (contd)

In addition to his professional practice, Dr. Goldschmidt played a very active role in his community in many other ways. He served the Pickaway County Action Committee, the Professional Division of Pickaway County's United Appeal, Easter Seals, Heart Fund Drive, the Chillicothe Hospital Veterans Program, the Boy Scouts, and the Girl Scouts. He was a member of the Jaycees, Kiwanis, Rotary, the American Legion, VFW, the Shrine, and was a member for over 60 years of both the BPO Elks and the Heber Masonic Lodge.

He served on the Circleville City Council and was a director of the local Savings Bank. He was a past exalted ruler of the local Elks lodge and past state president of the Ohio Elks Association. It is no surprise that in 1973 he was selected to receive the coveted Ohio State University Citizenship Award for community service outside one's profession. In 1979, the Circleville Jaycees named him Outstanding Senior Citizen. He was inducted into the Elks Hall of Fame in 1992 and was elected to the office of Grand Tiler of the Grand Lodge of the BPOE in 1993.

Dr. Goldschmidt is remembered for his passion for his profession and for the welfare of others.

On behalf of the University community, the Board of Trustees expresses to the family of David S. Goldschmidt its deepest sympathy and sense of understanding of their loss. It was directed that this resolution be inscribed upon the minutes of the Board of Trustees and that a copy be tendered to his family as an expression of the Board's heartfelt sympathy.

William S. Guthrie

The Board of Trustees of The Ohio State University expresses its sorrow upon the death on January 2, 2002, of William S. Guthrie, former executive dean for Student Relations and former assistant professor of Social Work.

Mr. Guthrie was associated with The Ohio State University in various administrative capacities for 25 years and was a recipient of the University's Distinguished Service Award. He earned two degrees in social work at Ohio State: a Bachelor's degree in 1932 and a Master's degree in 1939. He also studied at Columbia University. Mr. Guthrie joined the University staff in 1936 as assistant dean of men and director of student employment. He became acting junior dean of the College of Arts and Sciences in 1943, junior dean in 1946, and associate dean in 1956. From 1946 to 1957, he also served as director of orientation programs.

In 1957, he was appointed assistant to the vice president for Student Relations, and later that year was named executive dean for Student Relations. He served in that capacity, in the cabinet of President Novice Fawcett, until his retirement from the University in June 1961. As executive dean his areas of responsibility included student housing, orientation, international students, Ohio Union programs, student health, student organizations, student government, athletics, student conduct, counseling and testing services, and scholarship and financial aid.

Dean Guthrie's tenure spanned the Depression, the war years, and the incredible growth period following World War II. He was held in high esteem by students and colleagues and was recognized as a national leader in his field, having led a Ford Foundation study of student housing and served as president of the National Association of Student Personnel Administrators. He was known for his keen interest in students, his fundamental fairness, diplomacy, expertise and compassion. Those who worked closely with him remarked especially on Dean Guthrie's ability to keep open the channels of communication among students, faculty and administrators and "to guide the healthy ferment of student life along lines of lasting progress."

Following his retirement from Ohio State, Mr. Guthrie had a distinguished business career, serving for 17 years as board chairman, president, and chief executive officer of Buckeye Federal Savings and Loan Association. He maintained close ties with the University and held offices in the Alumni Association and the Development Fund. He was a member of the search committee

RESOLUTIONS IN MEMORIAM (contd)

William S. Guthrie (contd)

that nominated Harold Enarson as University president. He was an active member of many community educational, philanthropic, and cultural organizations and the recipient of numerous awards for his service.

On behalf of the University community, the Board of Trustees expresses to the family of William S. Guthrie its deepest sympathy and sense of understanding of their loss. It was directed that this resolution be inscribed upon the minutes of the Board of Trustees and that a copy be tendered to his family as an expression of the Board's heartfelt sympathy.

Franklin M. Ludden

The Board of Trustees of The Ohio State University expresses its sorrow upon the death on January 11, 2002, of Franklin M. Ludden, Professor Emeritus in the Department of History of Art.

Educated at Harvard University, Professor Ludden was first an historian of the U.S. Third Army in the Battle of the Bulge, then a faculty member at the University of Michigan before coming to The Ohio State University in 1955. He subsequently served as chair of the Department of History of Art from 1960-1978. During his tenure as chair, the department saw its largest expansion in faculty and offerings, broadening the specialties from Western to include Asian, Islamic, and African art. He led the way in hiring faculty from a variety of the best American graduate programs. He was influential in making the OSU Fine Arts Library one of the best in medieval art in the Big Ten.

He was a prolific and versatile teacher of medieval art and architecture, modern architecture, research methodologies, historiography, and theory. He was also one of the guiding forces behind the founding of OSU's Center for Medieval and Renaissance Studies and of the private faculty research club, the ZERO Club; until the very end of his life he was a regular lunch member of the Faculty Club. With his wife Gillie, he participated in the cultural life of Columbus in such organizations as the Columbus Museum of Art and the Crichton Club.

Since his retirement in 1983, he remained remarkably active in teaching the historiography course, and later in giving guest lectures on Panofsky's work. He continued to direct several dissertations in medieval art and modern architecture and advised many recent graduate students, providing useful tips on bibliography and interpretations.

Another lasting contribution to the History of Art Department was made by Franklin and Gillie in 1986, with their generous gift of the Ludden Lecture Series in Western Art. This lecture series brings to Ohio State some of the foremost intellectually alive art historical thinkers and theorists, and was the stimulus for creating a new faculty position in theory in 1990.

Until his last months he remained actively involved in the intellectual and social life of art history and of The Ohio State University. At the most recent Ludden Lecture last fall, which appropriately was given by David Rosand on the topic of a great art historian, Meyer Schapiro, who like Franklin Ludden devoted his research to both medieval and modern art, Franklin was delightedly involved in the discussion and talk after the lecture and during the dinner.

For many of us as his colleagues and for his students as well, Franklin Ludden will be remembered as one of the most active minds and lively participants in the life of art history, as a conference participant, teacher, traveler, and great conversationalist.

On behalf of the University community, the Board of Trustees expresses to the family of Franklin M. Ludden its deepest sympathy and sense of understanding of their loss. It was directed that this resolution be inscribed upon the minutes of the Board of Trustees and that a copy be tendered to his family as an expression of the Board's heartfelt sympathy.

RESOLUTIONS IN MEMORIAM (contd)

Charles M. Martin

The Board of Trustees of The Ohio State University expresses its sorrow upon the death on November 1, 2001, of Charles McClellan Martin, Professor Emeritus in the Ohio State University Extension and the Department of Animal Sciences.

From 1943-46, Charles Martin was a first lieutenant in the U.S. Army Corps of Engineers serving the Asiatic-Pacific theatre. He earned a Bachelor of Science degree with "High Distinction" in animal husbandry from the University of Kentucky in 1948, a Master of Science degree in animal nutrition from the University of Kentucky in 1949, and a Ph.D. degree in animal husbandry from Cornell University in 1952.

Professor Martin joined the faculty of The Ohio State University in 1965 as associate professor in the Ohio State University Cooperative Extension Service. He was the area extension agent – animal industry in the Wooster area. In 1970 he was promoted to professor and his assignment was changed to district specialist – animal industry in 1984. Dr. Martin was also a member of the faculty in the Department of Animal Sciences. He retired in 1987 and was awarded the title Professor Emeritus.

Dr. Martin's professional experience before coming to The Ohio State University included the following positions: a livestock specialist with the University of Kentucky Extension Service in Eastern Kentucky from 1961-65; a nutritionist with the Agricultural Research Center, Charles Pfizer and Company, Inc., at Terre Haute, IN, from 1959-61; a livestock specialist and later a district sales manager with the Quaker Oats Company, Chattanooga, TN, from 1956-59; and an associate professor of animal husbandry at Auburn University in Alabama from 1952-56.

Professor Emeritus Charles M. Martin served several parts of the livestock industry with emphasis on adult education throughout his professional career. These contributions in providing excellent Extension educational programs during his career earned him the respect and admiration of coworkers and associates throughout the state.

On behalf of the University community, the Board of Trustees expresses to the family of Charles M. Martin its deepest sympathy and sense of understanding of their loss. It was directed that this resolution be inscribed upon the minutes of the Board of Trustees and that a copy be tendered to his family as an expression of the Board's heartfelt sympathy.

Richard H. Wilson

The Board of Trustees of The Ohio State University expresses its sorrow upon the death on January 2, 2002, of Richard H. Wilson, Professor Emeritus in the Department of Human and Community Resource Development.

Professor Wilson earned his Bachelor of Science degree in agricultural education from The Ohio State University in 1943. He served in the U.S. Army from 1943-47 as a lieutenant in the 97th Infantry Division and was involved in combat leading to the end of WWII in Germany. Thereafter, his unit was transferred to Japan for post-war occupational duty.

Professor Wilson returned to Ohio State, where he earned an M.A. degree in 1951 and a Ph.D. degree in 1955. He served as an instructor in the Department of Agricultural Education from 1953-57; an assistant professor from 1957-1962; an associate professor from 1962-69; and as professor from 1969 until he was awarded the title of Professor Emeritus upon his retirement in 1979.

Throughout his career, Professor Wilson was highly regarded for his professional contributions. His academic specialization was in agricultural teacher education, where he supervised the preparation of student teachers of agriculture in the public schools of Ohio. He was the author of

RESOLUTIONS IN MEMORIAM (contd)

Richard H. Wilson (contd)

articles that were published in The Agricultural Education Magazine and served as editor of the Ohio Vocational Reporter (newsletter of the Ohio Vocational Association) from 1957-63.

Professor Wilson was a member of Alpha Gamma Sigma fraternity. He was also a member of the Ohio Vocational Association (OVA); the American Association of Teacher Educators in Agriculture (AATEA), where he served a term as vice president; and the American Vocational Association (AVA).

In addition to his service at The Ohio State University, Professor Wilson taught as a visiting professor at Michigan State, New Mexico State University, and Clemson University. He also served as a consultant to the National Center for Vocational and Technical Education from 1967-68 and to the University of Rhode Island in 1973-74. He was a member of the National Advisory Board of the Educational Resources Information Center for Rural Education as well.

On behalf of the University community, the Board of Trustees expresses to the family of Richard H. Wilson, its deepest sympathy and sense of understanding of their loss. It was directed that this resolution be inscribed upon the minutes of the Board of Trustees and that a copy be tendered to his family as an expression of the Board's heartfelt sympathy.

REPORT OF RESEARCH CONTRACTS AND GRANTS

Resolution No. 2002-91

Synopsis: The reports on research and other sponsored program contracts and grants and the summary for January 2002 are presented for Board acceptance.

WHEREAS monies are solicited and received on behalf of the University from governmental, industrial, and other agencies in support of research, instructional activities, and service; and

WHEREAS such monies are received through The Ohio State University Research Foundation:

NOW THEREFORE

BE IT RESOLVED, That the research agreement between The Ohio State University and The Ohio State University Research Foundation for the contracts and grants reported herein during the month of January 2002 be approved.

REPORT ON UNIVERSITY DEVELOPMENT

Resolution No. 2002-92

Synopsis: The report on the receipt of gifts and the summary for January 2002 are presented for Board acceptance.

WHEREAS monies are solicited and received on behalf of the University from alumni, industry, and various individuals in support of research, instructional activities, and service; and

WHEREAS such gifts are received through The Ohio State University Development Fund and The Ohio State University Foundation; and

REPORT ON UNIVERSITY DEVELOPMENT (contd)

WHEREAS this report includes the establishment of The Mildred E. Newton Professorship; and

WHEREAS this report includes the establishment of sixteen (16) new named endowed funds and the amendment of one (1) named endowed fund:

NOW THEREFORE

BE IT RESOLVED, That the acceptance of the report from The Ohio State University Development Fund and The Ohio State University Foundation during the month of January 2002 be approved.

TOTAL UNIVERSITY PRIVATE SUPPORT

July through January
2000 Compared to 2001

GIFT RECEIPTS BY DONOR TYPE

	Dollars July through January		
	<u>2000</u>	<u>2001</u>	<u>%Change</u>
Individuals:			
Alumni (Current Giving)	\$20,656,548	\$22,925,456	11
Alumni (From Bequests)	<u>1,615,749</u>	<u>2,630,919</u>	63
Alumni Total	\$22,272,297	\$25,556,375	15
Non-Alumni (Current Giving)	\$15,152,250	\$10,292,270	(32)
Non-Alumni (From Bequests)	<u>9,233,277</u>	<u>2,728,117</u>	(70)
Non-Alumni Total	\$24,385,527	\$13,020,387	(47)
Individual Total	\$46,657,824	\$38,576,762	(17 ^A)
Corporations/Corp/Foundations	\$23,797,477	\$24,020,026	1
Private Foundations	\$10,472,416	\$14,329,142	37 ^B
Associations and Other Organizations	<u>\$2,609,576</u>	<u>\$2,736,754</u>	5
Total	\$83,537,293	\$79,662,684	(5)

NOTES

- A Overall individual giving is down 17% in that gifts at the \$10,000 or more level are down 24% (\$34.8 million from 364 gifts last year compared with \$26.4 million from 334 gifts this year.)
- B Foundation giving at the \$10,000 or more level is up for the first seven months of the fiscal year (\$9.8 million from 127 gifts last year; \$13.7 million from 141 gifts this year).

REPORT ON UNIVERSITY DEVELOPMENT (contd)

TOTAL UNIVERSITY PRIVATE SUPPORT (contd)

July-January
2000 Compared to 2001

GIFT RECEIPTS BY PURPOSE

	Dollars July through January		
	<u>2000</u>	<u>2001</u>	<u>% Change</u>
Gift Receipts to Current Use and Endowment Funds:			
Buildings/Equipment	\$9,443,660	\$14,630,117	55
Faculty Support	\$6,425,802	\$7,883,346	23
Program Support	\$52,775,849	\$42,357,304	(20)
Student Financial Aid	\$8,021,481	\$8,919,226	11
Annual Funds-Colleges/Departments	\$5,990,816	\$5,120,132	(15)
Annual Funds-University	<u>\$879,685</u>	<u>\$752,559</u>	(14)
Total	\$83,537,293	\$79,662,684	(5)

GIFT ADDITIONS TO ENDOWMENT

Dollars
July through January

<u>2000</u>	<u>2001</u>	<u>% Change</u>
\$21,432,320	\$25,022,292	17%

REPORT ON UNIVERSITY DEVELOPMENT (contd)

THE OHIO STATE UNIVERSITY DEVELOPMENT FUND

	<u>Previous Gifts</u>	<u>Current Gifts</u>	<u>Total Gifts</u>
<u>Establishment of Named Endowed Professorship</u>			
The Mildred E. Newton Professorship (Used to support a professorship in the College of Nursing; provided by gifts from The Ohio State University Nurses Alumnae Association) (Grandfathered)		\$555,042.00	\$555,042.00
<u>Establishment of Named Endowed Funds</u>			
The Fisher College Building Complex Fund (Used to support the Fisher College building complex and activities therein; provided by gifts from donors to The Max M. Fisher College of Business)		\$4,010,010.00	\$4,010,010.00
The University Pathology Services Anatomic Pathology Professorship Fund (Used to support a future professorship in the Department of Pathology in the College of Medicine and Public Health; provided by gifts from University Pathology Services and other friends of the Department of Pathology)		\$175,000.00	\$175,000.00
The University Pathology Services Clinical Pathology Professorship Fund (Used to support a future professorship in the Department of Pathology in the College of Medicine and Public Health; provided by gifts from University Pathology Services and other friends of the Department of Pathology)		\$175,000.00	\$175,000.00
The Bostic-Georges Faculty Service Award Fund (Used to provide a faculty member award at the Fisher College of Business; provided by gifts from the Bostic and Georges families and other friends)		\$50,000.00	\$50,000.00
The Dr. Donald R. Redman Food Animal Health Research Program Research and Education Fund (Used to enhance the Food Animal Health Research Program at OARDC; provided by a gift from the Food Animal Health Research Program)		\$26,248.00	\$26,248.00
The Verland W. and Brian Belt Engineering Scholarship Fund (Used to provide scholarships to students in the College of Engineering; provided by gifts from Verland W. Belt and Brian Belt)		\$25,000.00	\$25,000.00

REPORT ON UNIVERSITY DEVELOPMENT (contd)

THE OHIO STATE UNIVERSITY FOUNDATION

	<u>Previous Gifts</u>	<u>Current Gifts</u>	<u>Total Gifts</u>
<u>Establishment of Named Endowed Funds</u>			
The Ferris P. Copper and Lillian Copper Memorial Endowment Fund in Medicine (Used to support the College of Medicine and Public Health; provided by gifts made in memory of Ferris and Lillian Copper from his estate)		\$808,263.92	\$808,263.92
The Raymond E. Mason Endowment Fund for Excellence (Used to support student activities and faculty in the Fisher College of Business; provided by gifts from Raymond E. Mason, Jr.)		\$800,000.00	\$800,000.00
The Paul A. Smith and Ethel I. Smith 4-H Scholarship Endowment Fund (Used to provide scholarships in the College of Food, Agricultural, and Environmental Sciences; provided by gifts from the estate of Paul A. and Ethel I. Smith)		\$417,407.69	\$417,407.69
The Clara Hilberg Teller Endowed Scholarship Fund (Used to provide scholarships in the College of Humanities; provided by gifts from the estate of Clara Hilberg Tiller)		\$80,000.00	\$80,000.00
The Ruth C. and Ralph O. Jentz Dean's Innovation Fund (Used to further the activities of the College of Veterinary Medicine; provided by a gift from the estate of Ralph O. Jentz)		\$50,000.00	\$50,000.00
The John Esselburn Scholarship Fund (Used to support scholarships for students in the Fisher College of Business; provided by gifts from John A. Esselburn and Kathyne Esselburn)		\$30,000.00	\$30,000.00
The Lynn Ackerman Hirsch Memorial Fund for Cancer Research (Used to support research at the Comprehensive Cancer Center – The Arthur G. James Cancer Hospital and Richard J. Solove Research Institute; provided by a gift from Kenneth Ackerman)		\$26,946.62	\$26,946.62
The Paul S. Metzger, M.D. and Lee Metzger Medical Heritage Center Endowment Fund (Used to support the Medical Heritage Center's historic collections in the Prior Health Sciences Library; provided by gifts from Paul S. Metzger, M.D. and Lee Metzger)		\$25,570.53	\$25,570.53

REPORT ON UNIVERSITY DEVELOPMENT (contd)

THE OHIO STATE UNIVERSITY FOUNDATION (contd)

	<u>Previous Gifts</u>	<u>Current Gifts</u>	<u>Total Gifts</u>
<u>Establishment of Named Endowed Funds (contd)</u>			
The Ohio Agricultural Research and Development Center Innovation Fund (Used to enhance and foster innovative concepts and visions that impact and advance excellence in agriculture; provided by a gift from Forest and Karen Muir)		\$25,000.00	\$25,000.00
The Hofmann Family Foundation Athletic Scholarship Fund (Used to supplement scholarship costs of members of the varsity men's hockey team; provided by gifts from The Hofmann Family Foundation)		\$25,000.00	\$25,000.00
<u>Change in Name and Description of Named Endowed Fund</u>			
From: The Anna Sborowitz Scholarship Fund			
To: The Anna Sborowitz Endowment Fund			
Total		\$7,304,488.76	\$7,304,488.76

THE OHIO STATE UNIVERSITY DEVELOPMENT FUND

Establishment of Named Endowed Professorship

The Mildred E. Newton Professorship

The Mildred E. Newton Scholarship Fund was established July 14, 1966, by the Board of Trustees of The Ohio State University with gifts from The Ohio State University Nurses Alumnae Association along with friends, alumni, and faculty of the College of Nursing in honor of Dr. Mildred E. Newton, former director of the School of Nursing (September 1951 to July 1968). The required funding level (grandfathered) has been reached, and the professorship was established on March 1, 2002.

All gifts are to be invested in the University's Permanent Endowment Fund, under the rules and regulations adopted by the Board of Trustees of The Ohio State University, with the right to invest and reinvest as occasion dictates.

The annual income shall be used to provide salary and program support for the work of a distinguished teacher and scholar in nursing, nursing education, and health care in the College of Nursing. Distribution will be made at the recommendation of the dean of the College of Nursing.

It is the desire of the donors that this fund should benefit the University in perpetuity. If the need for this fund should cease to exist or so diminish as to provide unused income, then another use shall be designated by the Board of Trustees in consultation with the dean of the College of Nursing or program administrative officer in order to carry out the desire of the donors.

\$555,042.00 (Grandfathered)

REPORT ON UNIVERSITY DEVELOPMENT (contd)

THE OHIO STATE UNIVERSITY DEVELOPMENT FUND (contd)

Establishment of Named Endowed Funds

The Fisher College Building Complex Fund

The Fisher College Building Complex Fund was established March 1, 2002, by the Board of Trustees of The Ohio State University with gifts from donors to The Max M. Fisher College of Business.

All gifts are to be invested in the University's Permanent Endowment Fund, under the rules and regulations adopted by the Board of Trustees of The Ohio State University, with the right to invest and reinvest as occasion dictates.

The annual income shall be used by the dean of the Fisher College to support the building complex and activities therein.

It is the desire of the donors that this fund should benefit the University in perpetuity. If the need for this fund should cease to exist or so diminish as to provide unused income, then another use shall be designated by the Board of Trustees in consultation with the dean of The Max M. Fisher College of Business in order to carry out the desire of the donors.

\$4,010,010.00

The University Pathology Services Anatomic Pathology Professorship Fund

The University Pathology Services Anatomic Pathology Professorship Fund was established March 1, 2002, by the Board of Trustees of The Ohio State University with gifts from University Pathology Services, Columbus, Ohio, and from other friends of the Department of Pathology.

All gifts are to be invested in the University's Permanent Endowment Fund, under the rules and regulations adopted by the Board of Trustees of The Ohio State University, with the right to invest and reinvest as occasion dictates.

The annual income shall be added to the fund until it reaches the level of \$750,000, at which time it will provide for a professorship position. The professorship shall support the advancement of medical knowledge in the field of pathology research, both basic and clinical, and shall be held by an individual who is or shall be a member of the Department of Pathology in the College of Medicine and Public Health. The position shall be held by a nationally eminent faculty member who has distinguished himself/herself in the performance of pathology research, who maintains an active productive research program, and who is an effective educator-teacher.

Selection shall be made as recommended by the senior vice president for Health Sciences and dean of the College of Medicine and Public Health in consultation with the chairperson of the Department of Pathology. The activities of the endowed professorship holder shall be reviewed no less than every five years by the senior vice president for Health Sciences and dean of the College of Medicine and Public Health to determine compliance with the intent of the donor as well as the academic and research standards of the University.

It is the desire of the donors that this fund should benefit the University in perpetuity. If the need for this fund should cease to exist or so diminish as to provide unused income, then another use shall be designated by the Board of Trustees in consultation with the senior vice president for Health Sciences and dean of the College of Medicine and Public Health, and the chairperson of the Department of Pathology in order to carry out the desire of the donors.

\$175,000.00

REPORT ON UNIVERSITY DEVELOPMENT (contd)

THE OHIO STATE UNIVERSITY DEVELOPMENT FUND (contd)

Establishment of Named Endowed Funds (contd)

The University Pathology Services Clinical Pathology Professorship Fund

The University Pathology Services Clinical Pathology Professorship Fund was established March 1, 2002, by the Board of Trustees of The Ohio State University with gifts from University Pathology Services, Columbus, Ohio, and from other friends of the Department of Pathology.

All gifts are to be invested in the University's Permanent Endowment Fund, under the rules and regulations adopted by the Board of Trustees of The Ohio State University, with the right to invest and reinvest as occasion dictates.

The annual income shall be added to the fund until it reaches the level of \$750,000, at which time it will provide for a professorship position. The professorship shall support the advancement of medical knowledge in the field of pathology research, both basic and clinical, and shall be held by an individual who is or shall be a member of the Department of Pathology in the College of Medicine and Public Health. The position shall be held by a nationally eminent faculty member who has distinguished himself/herself in the performance of pathology research, who maintains an active productive research program, and who is an effective educator-teacher.

Selection shall be made as recommended by the senior vice president for Health Sciences and dean of the College of Medicine and Public Health in consultation with the chairperson of the Department of Pathology. The activities of the endowed professorship holder shall be reviewed no less than every five years by the senior vice president for Health Sciences and dean of the College of Medicine and Public Health to determine compliance with the intent of the donor as well as the academic and research standards of the University.

It is the desire of the donors that this fund should benefit the University in perpetuity. If the need for this fund should cease to exist or so diminish as to provide unused income, then another use shall be designated by the Board of Trustees in consultation with the senior vice president for Health Sciences and dean of the College of Medicine and Public Health, and the chairperson of the Department of Pathology in order to carry out the desire of the donors.

\$175,000.00

The Bostic-Georges Faculty Service Award Fund

The Bostic-Georges Faculty Service Award Fund was established March 1, 2002, by the Board of Trustees of The Ohio State University with gifts from the Bostic family of Columbus, Ohio, the Georges family of Westerville, Ohio, and other friends.

All gifts are to be invested in the University's Permanent Endowment Fund, under the rules and regulations adopted by the Board of Trustees of The Ohio State University, with the right to invest and reinvest as occasion dictates.

The annual income shall be used to provide an award to a faculty member at The Max M. Fisher College of Business who provides exemplary service to the College/University community.

It is the desire of the donors that this fund should benefit the University in perpetuity. If the need for this fund should cease to exist or so diminish as to provide unused income, then another use shall be designated by the Board of Trustees in consultation with the dean of The Max M. Fisher College of Business in order to carry out the desire of the donors.

\$50,000.00

REPORT ON UNIVERSITY DEVELOPMENT (contd)

THE OHIO STATE UNIVERSITY DEVELOPMENT FUND (contd)

Establishment of Named Endowed Funds (contd)

The Dr. Donald R. Redman Food Animal Health Research Program
Research and Education Fund

The Dr. Donald R. Redman Food Animal Health Research Program Research and Education Fund was established March 1, 2002, by the Board of Trustees of The Ohio State University with a gift from the Food Animal Health Research Program.

All gifts are to be invested in the University's Permanent Endowment Fund, under the rules and regulations adopted by the Board of Trustees of The Ohio State University, with the right to invest and reinvest as occasion dictates.

The annual income shall be used to enhance the Food Animal Health Research Program (FAHRP) at the Ohio Agricultural Research and Development Center. Uses of the fund shall be limited to support guest lectureships, symposia, and graduate student support in the Food Animal Health Research Program. The distribution of the funds will be at the discretion of the program head, in consultation with the faculty of FAHRP. Unused income shall be reinvested in the principal.

It is the desire of the donor that this fund should benefit the University in perpetuity. If the need for this fund should cease to exist or so diminish as to provide unused income, then another use shall be designated by the Board of Trustees in consultation with the director of the Ohio Agricultural Research and Development Center and program head of the Food Animal Health Research Program in order to carry out the desire of the donor.

\$26,248.00

The Verland W. and Brian Belt Engineering Scholarship Fund

The Verland W. and Brian Belt Engineering Scholarship Fund was established March 1, 2002, by the Board of Trustees of The Ohio State University with gifts from Verland W. Belt (B.C.E. 1937) and Brian Belt (B.I.E. 1968, M.S. 1969).

All gifts are to be invested in the University's Permanent Endowment Fund, under the rules and regulations adopted by the Board of Trustees of The Ohio State University, with the right to invest and reinvest as occasion dictates.

The annual income shall provide one or more merit scholarships to students majoring in engineering. Selection will be made by the dean of the College of Engineering in consultation with the University Committee on Student Financial Aid.

It is the desire of the donors that this fund should benefit the University in perpetuity. If the need for this fund should cease to exist or so diminish as to provide unused income, then another use shall be designated by the Board of Trustees in consultation with the appropriate college dean, department chairperson, or program administrative officer in order to carry out the desire of the donors.

\$25,000.00

REPORT ON UNIVERSITY DEVELOPMENT (contd)

THE OHIO STATE UNIVERSITY FOUNDATION

Establishment of Named Endowed Funds

The Ferris P. Copper and Lillian Copper Memorial Endowment Fund in Medicine

The Ferris P. Copper and Lillian Copper Memorial Endowment Fund in Medicine was established March 1, 2002, in accordance with the guidelines approved by the Board of Directors of The Ohio State University Foundation with gifts made in memory of Ferris and Lillian Copper from the estate of Ferris Copper (B.F.A. 1940) of Schenectady, New York.

All gifts are to be invested by the Foundation, under the rules and regulations adopted by the Foundation Board of Directors with the right to invest and reinvest as occasion dictates.

The annual income shall be used to support the College of Medicine and Public Health as determined by the senior vice president for Health Sciences and dean of the College of Medicine and Public Health, with the objective that these funds may be allowed to increase in value so that such increases would make it possible to build (or be seed funds to build) a needed facility at the academic medical campus if determined as most beneficial by the senior vice president for Health Sciences and dean of the College of Medicine and Public Health.

In addition, each time the market value of this endowment fund doubles from its original gift value (that of \$802,759), twenty-five percent (25%) of the principal of said fund may be utilized for any needs of the College as the senior vice president for Health Sciences and dean of the College of Medicine and Public Health may direct.

Suitable recognition of this gift will be made in the form of a memorial plaque or other naming mechanism to honor Ferris P. Copper and Lillian Copper.

It is the desire of the donor that this fund should benefit the University in perpetuity. If the need for this fund should cease to exist or so diminish as to provide unused income, then another use shall be designated by the Foundation Board in consultation with the senior vice president for Health Sciences and dean of the College of Medicine and Public Health in order to carry out the desire of the donor.

\$808,263.92

The Raymond E. Mason Endowment Fund for Excellence

The Raymond E. Mason Endowment Fund for Excellence was established March 1, 2002, in accordance with the guidelines approved by the Board of Directors of The Ohio State University Foundation, with gifts from Raymond E. Mason, Jr. (B.S.Bus.Adm. 1941).

All gifts are to be invested by the Foundation, under the rules and regulations adopted by the Foundation's Board of Directors, with the right to invest and reinvest as occasion dictates.

The annual income shall be used in The Max M. Fisher College of Business primarily to attract and retain talented faculty and also to support student activities including participation in business solution teams, interaction with business executives/owners, entrepreneurship, emerging markets study, and initiatives which develop understanding of the free enterprise system.

Yearly unspent income will be returned to the principal to enhance the annual income available to support faculty and students.

It is the desire of the donor that this fund should benefit the University in perpetuity. Should The Ohio State University and The Max M. Fisher College of Business agree that management education will not be an academic offering of the institution, then the University, in consultation with the donor or his designee, will re-designate the income of this fund to another purpose at

REPORT ON UNIVERSITY DEVELOPMENT (contd)

THE OHIO STATE UNIVERSITY FOUNDATION (contd)

Establishment of Named Endowed Funds (contd)

The Raymond E. Mason Endowment Fund for Excellence (contd)

The Ohio State University which supports programs that are of interest to the donor. If no such agreement can be reached between the University and the donor or his designee, the principal of the fund will revert to the Raymond E. Mason Foundation.

\$800,000.00

The Paul A. Smith and Ethel I. Smith 4-H Scholarship Endowment Fund

The Paul A. Smith and Ethel I. Smith 4-H Scholarship Endowment Fund was established March 1, 2002, in accordance with the guidelines approved by the Board of Directors of The Ohio State University Foundation, with gifts from the estate of Paul A. and Ethel I. Smith of Navarre, Ohio.

All gifts are to be invested by the Foundation, under the rules and regulations adopted by the Foundation's Board of Directors, with the right to invest and reinvest as occasion dictates.

The annual income shall be used to provide scholarships to young people interested in pursuing an education in farming and agriculture at the College of Food, Agricultural, and Environmental Sciences in Columbus and at the regional campuses, including the School of Natural Resources and the Agricultural Technical Institute. The criteria for awarding the scholarships shall be based on a student's documented involvement with 4-H leadership, citizenship, and school and community activities, along with the ability to maintain a GPA of at least 2.0. Scholarship recipients will be selected by an Ohio 4-H Awards Selection Committee. The scholarships will be awarded in consultation with the University Committee on Student Financial Aid.

It is the desire of the donors that this fund should benefit the University in perpetuity. If the need for this fund should cease to exist or so diminish as to provide unused income, then another use shall be designated by the Foundation Board in consultation with the director of Ohio State University Extension in order to carry out the desire of the donors.

\$417,407.69

The Clara Hilberg Teller Endowed Scholarship Fund

The Clara Hilberg Teller Endowed Scholarship Fund in the College of Humanities was established March 1, 2002, in accordance with the guidelines approved by the Board of Directors of The Ohio State University Foundation, with gifts from the estate of Clara Hilberg Teller (B.A. 1955).

All gifts are to be invested by the Foundation, under the rules and regulations adopted by the Foundation's Board of Directors, with the right to invest and reinvest as occasion dictates.

The annual income shall be used to provide scholarships to students who are majoring in the Humanities and who maintain a GPA of 3.0 or better. The scholarships will be awarded in consultation with the University Committee on Student Financial Aid.

It is the desire of the donor that this fund should benefit the University in perpetuity. If the need for this fund should cease to exist or so diminish as to provide unused income, then another use shall be designated by the Foundation Board as recommended to the dean of the College of Humanities in order to carry out the desire of the donor.

\$80,000.00

REPORT ON UNIVERSITY DEVELOPMENT (contd)

THE OHIO STATE UNIVERSITY FOUNDATION (contd)

Establishment of Named Endowed Funds (contd)

The Ruth C. and Ralph O. Jentz Dean's Innovation Fund

The Ruth C. and Ralph O. Jentz Dean's Innovation Fund was established March 1, 2002, in accordance with the guidelines approved by the Board of Directors of The Ohio State University Foundation, with a gift from the estate of Ralph O. Jentz, Cincinnati, Ohio.

All gifts are to be invested by the Foundation, under the rules and regulations adopted by the Foundation's Board of Directors, with the right to invest and reinvest as occasion dictates.

The annual income shall be used at the discretion of the dean of the College of Veterinary Medicine to further the activities of the College. Any unused income in any given year shall be returned to principal.

It is the desire of the donor that this fund should benefit the University in perpetuity. If the need for this fund should cease to exist or so diminish as to provide unused income, then another use shall be designated by the Foundation Board as recommended by the dean of the College of Veterinary Medicine in order to carry out the desire of the donor.

\$50,000.00

The John Esselburn Scholarship Fund

The John Esselburn Scholarship Fund was established March 1, 2002, in accordance with the guidelines approved by the Board of Directors of The Ohio State University Foundation, with gifts from John A. Esselburn (B.S.Bus.Adm. 1967) and his wife Kathyrene Esselburn, of Naperville, Illinois, and Naples, Florida.

All gifts are to be invested by the Foundation, under the rules and regulations adopted by the Foundation's Board of Directors, with the right to invest and reinvest as occasion dictates.

The annual income shall be used by The Max. M. Fisher College of Business to support a scholarship(s) for a student in business, with preference to an operations management major who aspires to a career in manufacturing. The scholarship is open to any U.S. citizen on the basis of merit and unmet financial need, with option for renewal. The scholarship established by the donor is intended to assist students who are substantially self-supporting. The scholarship will be awarded in consultation with the University Committee on Student Financial Aid.

It is the desire of the donors that this fund should benefit the University in perpetuity. If the need for this fund should cease to exist or so diminish as to provide unused income, then another use shall be designated by the Foundation Board as recommended by the dean of the Fisher College of Business in order to carry out the desire of the donors.

\$30,000.00

The Lynn Ackerman Hirsch Memorial Fund For Cancer Research

The Lynn Ackerman Hirsch Memorial Fund for Cancer Research at the Comprehensive Cancer Center – The Arthur G. James Cancer Hospital and Richard J. Solove Research Institute was established March 1, 2002, in accordance with the guidelines approved by the Board of Directors of The Ohio State University Foundation with a gift from Lynn Ackerman Hirsch's brother, Kenneth Ackerman, of Columbus, Ohio.

All gifts to this fund are to be invested by the Foundation, under the rules and regulations adopted by the Foundation Board of Directors with the right to invest and reinvest as occasion dictates.

REPORT ON UNIVERSITY DEVELOPMENT (contd)

THE OHIO STATE UNIVERSITY FOUNDATION (contd)

Establishment of Named Endowed Funds (contd)

The Lynn Ackerman Hirsch Memorial Fund For Cancer Research (contd)

The annual income shall be used to support cancer research at the Comprehensive Cancer Center - The Arthur G. James Cancer Hospital and Richard J. Solove Research Institute at The Ohio State University as approved by the director of The Arthur G. James Cancer Hospital and Richard J. Solove Research Institute, the director of the Comprehensive Cancer Center, and the senior vice president for Health Sciences and dean of the College of Medicine and Public Health.

It is the desire of the donor that this fund should benefit the University in perpetuity. If the need for this fund should cease to exist or so diminish as to provide unused income, then another use shall be designated by the Foundation Board in consultation with the director of The Arthur G. James Cancer Hospital and Richard J. Solove Research Institute, the director of the Comprehensive Cancer Center, and the senior vice president for Health Sciences and dean of the College of Medicine and Public Health in order to carry out the desire of the donor.

\$26,946.62

The Paul S. Metzger, M.D. and Lee Metzger
Medical Heritage Center Endowment Fund

The Paul S. Metzger, M.D. and Lee Metzger Medical Heritage Center Endowment Fund was established March 1, 2002, in accordance with the guidelines approved by the Board of Directors of The Ohio State University Foundation with gifts from Paul S. Metzger, (M.D. 1948) and Lee Metzger (B.S.Nurs. 1949) of Columbus, Ohio.

All gifts are to be invested by the Foundation, under the rules and regulations adopted by the Foundation Board of Directors with the right to invest and reinvest as occasion dictates.

The annual income shall be used for support of the Medical Heritage Center's historic collections. Income distribution shall be made as recommended by the curator of the Medical Heritage Center and the director of the Prior Health Sciences Library in consultation with the senior vice president for Health Sciences and dean of the College of Medicine and Public Health. The income may support, but is not limited to, collection procurement, curatorial expenses, salaries for personnel, and activities required to support the Medical Heritage Center. If the need for this funding should cease to exist, then the fund will be dedicated to support the rare book collection of the Prior Health Sciences Library.

It is the desire of the donors that this fund should benefit the University in perpetuity. If the need for this fund should cease to exist or so diminish as to provide unused income, then another use shall be designated by the Foundation Board in consultation with the senior vice president for Health Sciences and dean of the College of Medicine and Public Health and the director of the Prior Health Sciences Library in order to carry out the desire of the donors.

\$25,570.53

The Ohio Agricultural Research and Development Center Innovation Fund

The Ohio Agricultural Research and Development Center (OARDC) Innovation Fund was established March 1, 2002, in accordance with the guidelines approved by the Board of Directors of The Ohio State University Foundation, with a gift from Forest (Ph.D. 1967) and Karen Muir of Wooster, Ohio.

REPORT ON UNIVERSITY DEVELOPMENT (contd)

THE OHIO STATE UNIVERSITY FOUNDATION (contd)

Establishment of Named Endowed Funds (contd)

The Ohio Agricultural Research and Development Center Innovation Fund (contd)

All gifts are to be invested by the Foundation, under the rules and regulations adopted by the Foundation's Board of Directors, with the right to invest and reinvest as occasion dictates.

The annual income shall be used by the director of the Ohio Agricultural Research and Development Center to enhance and foster innovative concepts and visions that impact and advance excellence in agriculture. Unused income shall be reinvested in the principal.

It is the desire of the donors that this fund should benefit the University in perpetuity. If the need for this fund should cease to exist or so diminish as to provide unused income, then another use shall be designated by the Foundation Board in consultation with the director of the Ohio Agricultural Research and Development Center in order to carry out the desire of the donor.

\$25,000.00

The Hofmann Family Foundation Athletic Scholarship Fund

The Hofmann Family Foundation Athletic Scholarship Fund was established March 1, 2002, in accordance with the guidelines approved by the Board of Directors of The Ohio State University Foundation, with gifts from The Hofmann Family Foundation of Pittsburgh, Pennsylvania. Any publicity concerning or recognition of this gift should be given to Robert G. Hofmann, II.

All gifts are to be invested by the Foundation, under the rules and regulations adopted by the Foundation's Board of Directors, with the right to invest and reinvest as occasion dictates.

The annual income shall be used to supplement the student-athlete grant-in-aid scholarship costs of student athletes who are members of the varsity men's hockey team who are pursuing undergraduate degrees at The Ohio State University. The director of Athletics shall select recipients in consultation with the head hockey coach, the Student Athlete Support Services Office, and the University Committee on Student Financial Aid.

It is the desire of the donor that this fund should benefit the University in perpetuity. If the need for this fund should cease to exist or so diminish as to provide unused income, then another use shall be designated by the Foundation Board as recommended by the director of Athletics in order to carry out the desire of the donor.

\$25,000.00

Change in Name and Description of Named Endowed Fund

The Anna Sborowitz Endowment Fund

The Anna Sborowitz Scholarship Fund was established October 6, 1995, in accordance with the guidelines approved by the Board of Directors of The Ohio State University Foundation, with gifts from Paul K. Sorren (B.S.Bus.Adm. 1946) of Miami Beach, Florida. The name and description were revised on March 1, 2002.

All gifts are to be invested by the Foundation, under the rules and regulations adopted by the Foundation's Board of Directors, with the right to invest and reinvest as occasion dictates.

REPORT ON UNIVERSITY DEVELOPMENT (contd)

THE OHIO STATE UNIVERSITY FOUNDATION (contd)

Change in Name and Description of Named Endowed Fund (contd)

The Anna Sborowitz Endowment Fund (contd)

The annual income shall be used to provide scholarships for students with disabilities enrolled full-time at The Ohio State University. The scholarships will be awarded in consultation with the University Committee on Student Financial Aid.

It is the desire of the donor that this fund should benefit the University in perpetuity. If the need for this fund should cease to exist or so diminish as to provide unused income, then another use shall be designated by the Foundation Board as recommended by the Office of Student Affairs and the Office for Disability Services in order to carry out the desire of the donor.

MODIFICATION OF ENDOWMENT INVESTMENTS POLICY

Resolution No. 2002-93

Synopsis: Revision of the University's Endowment Investments Policy is proposed.

WHEREAS the Board of Trustees, from time to time, has adopted specific policies governing various aspects of the management of the investment portfolios; and

WHEREAS there is a need for comprehensive policies to provide for the overall management of the investment portfolios; and

WHEREAS there is need to modify the comprehensive policies on occasion:

NOW THEREFORE

BE IT RESOLVED, That the following Endowment Investments Policy for The Ohio State University be adopted by the Board of Trustees; and

BE IT FURTHER RESOLVED, That the Treasurer be, and hereby is, directed and authorized to implement and administer this policy and to manage the Endowment investment portfolio in accordance with this Policy.

(See Appendix XXVII for background information, page 891.)

WAIVERS OF COMPETITIVE BIDDING REQUIREMENTS

Resolution No. 2002-94

OCTOBER – DECEMBER 2001

Synopsis: Acceptance of the quarterly report on waivers of competitive bidding requirements is proposed.

WHEREAS the Purchasing Policy of The Ohio State University adopted by the Board of Trustees on September 7, 1984, and revised on February 7, 1992, July 8, 1994, and November 7, 1997, provides that the President and/or the Vice President for Business and Finance, or for the Hospitals of the

WAIVERS OF COMPETITIVE BIDDING REQUIREMENTS (contd)

University and their related facilities, Vice President for Health Services, may grant a waiver from competitive bidding in the event of an emergency, when a sufficient economic reason exists or when the goods or services can be purchased from only a single source, with a report on such waivers to be made quarterly to this Board; and

WHEREAS the Senior Vice President for Business and Finance has submitted a report on waivers of competitive bidding requirements granted for the period of October - December, 2001; and

WHEREAS during the period covered, the Senior Vice President for Business and Finance, at the requests of the departments making the purchases and upon the recommendation of the Purchasing Department, 39 granted waivers of competitive bidding requirements for annual purchases totaling approximately \$4,494,100 as shown on the enclosed exhibit:

WHEREAS during the period covered, the Vice President for Health Services, at the requests of the Hospitals of the University and their related facilities making purchases, granted 30 waivers of competitive bidding requirements for annual purchases totaling approximately \$12,252,500 as shown on the enclosed exhibit:

NOW THEREFORE

BE IT RESOLVED, That the report on waivers of competitive bidding requirements for the period of October - December 2001, is hereby accepted.

(See Appendix XXVIII for background information, page 899.)

**EMPLOYMENT OF ARCHITECTS/ENGINEERS AND
REQUEST FOR CONSTRUCTION BIDS**

Resolution No. 2002-95

HEART HOSPITAL
OHIO 4-H CENTER
MULTI-PURPOSE TURF FIELD
LABORATORY ANIMAL FACILITY EXPANSION
ATI – SHISLER CENTER COURTYARD

Synopsis: Authorization to employ an architect/engineering firm for the Ohio 4-H Center, Multi-Purpose Turf Field and ATI – Shisler Center Courtyard projects and request construction bids for the Heart Hospital, Ohio 4-H Center, Multi-Purpose Turf Field, Laboratory Animal Facility Expansion, and ATI – Shisler Center Courtyard projects is requested.

WHEREAS the University desires to construct a new Heart Hospital to house an integrated cardiothoracic surgery and cardiology program; and

WHEREAS the total estimated project cost is \$82,200,000 and the total estimated construction cost is \$51,000,000, with funding provided by a generous gift from the Ross family (\$10,000,000), House Bill 640 (\$2,610,000), and future University bond proceeds with debt service paid by income from patient fees and/or future gifts to the Heart Hospital (\$69,590,000); and

WHEREAS the University desires to construct a new Ohio 4-H Center just north of the Dakan Hall site to house OSU 4-H Youth Development staff, OSU Extension programs, and those programs from the College of Food, Agricultural, and Environmental Sciences that will interact with 4-H; and

WHEREAS the total estimated project cost is \$9,110,627 and the total estimated construction cost is \$6,628,751, with funding provided by the Ohio 4-H Foundation Board; and

**EMPLOYMENT OF ARCHITECTS/ENGINEERS AND
REQUEST FOR CONSTRUCTION BIDS (contd)**

WHEREAS the University desires to install a new Multi-Purpose Turf Field on the northwest field of the Larkins four-field complex including installation of turf field lighting and filming platform for use as a practice field for the marching band, club sports, men's and women's soccer, lacrosse and field hockey, and flag football; and

WHEREAS the total estimated project cost is \$1,225,000 and the total estimated construction cost is \$1,018,010, with funding provided by University bond proceeds (\$264,000) with debt service paid by Transportation and Parking and Recreational Sports, gifts to the Marching Band (\$140,000), Business and Finance (\$150,000), and gifts to the University (\$671,000); and

WHEREAS the University desires to provide minor renovations in Building 1 and construct three modular buildings at the University Laboratory Animal Research Center to house laboratory animals with closely monitored HVAC and electrical services; and

WHEREAS the total estimated project cost is \$500,000 and the total estimated construction cost is \$ 459,894, with funding provided by the Office of Research; and

WHEREAS the University desires to construct a courtyard adjacent to the new Shisler Center on the ATI campus; and

WHEREAS the total estimated project cost is \$300,000 and the total estimated construction cost is \$255,975, with funding provided by House Bill 640:

NOW THEREFORE

BE IT RESOLVED, That the President and/or Senior Vice President for Business and Finance be authorized to select qualified architectural/engineering firms as necessary for the Ohio 4-H Center, Multi-Purpose Turf Field, and ATI – Shisler Center Courtyard projects and that the fees for these services be negotiated between the firms selected and the University; and

BE IT FURTHER RESOLVED, That the President and/or Senior Vice President for Business and Finance be authorized to request construction bids for the Ohio 4-H Center, Multi-Purpose Turf Field, Laboratory Animal Facility Expansion, and ATI – Shisler Center Courtyard projects in accordance with established University and State of Ohio procedures, and if satisfactory bids are received, to issue contracts with all actions to be reported to this Board at the appropriate time; and

BE IT FURTHER RESOLVED, That the President and/or Senior Vice President for Business and Finance be authorized to request construction bids for the generator installation, security system, building demolition, and site utilities for the Heart Hospital project in accordance with established University and State of Ohio procedures, and if satisfactory bids are received to issue contracts with all actions to be reported to the Board at the appropriate time; and

BE IT FURTHER RESOLVED, That, subject to the approval of a business plan and a memorandum of understanding by the appropriate University officials, the President and/or Senior Vice President for Business and Finance be authorized to request construction bids for the remaining construction phases of the Heart Hospital project in accordance with established University and State of Ohio procedures, and if satisfactory bids are received, to issue contracts with all actions to be reported to this Board at the appropriate time.

(Appendix XXIX for background information and maps, page 903.)

MAINTENANCE AND RENEWAL POLICY FOR UNIVERSITY FACILITIES

Resolution No. 2002-96

Synopsis: A policy to assure funding for maintenance and renewal of University facilities is proposed.

WHEREAS a supportive and attractive physical environment is a key element of the Academic Plan; and

WHEREAS a large deferred maintenance backlog detracts from the goals of the Academic Plan; and

WHEREAS the addition of space without funding for maintenance and renewal exacerbates future deferred maintenance problems:

NOW THEREFORE

BE IT RESOLVED, That plans for facilities and building renewal be included as a component of the business plan for every new capital project over \$1.5 million; and

BE IT FURTHER RESOLVED, That the attached Strategic Principles apply to the maintenance and renewal of University facilities; and

BE IT FURTHER RESOLVED, That renovation and replacement of academic buildings continue to be given priority for use of State capital dollars; and

BE IT FURTHER RESOLVED, That these policies and principles be effective immediately; and

BE IT FURTHER RESOLVED, That the President report annually to the Board of Trustees on compliance with this policy.

(See Appendix XXX for background information, page 913.)

UPDATING OF PURCHASING POLICY

Resolution No. 2002-97

Synopsis: The following modifications to update the University's policy on purchasing and competitive bidding is proposed.

WHEREAS the Board of Trustees adopted a policy on purchasing and competitive bidding in November 1997; and

WHEREAS it is in the best interests of the University to periodically update this policy to ensure that the University is taking advantage of procurement arrangements that will best meet the needs of the University for obtaining goods and services at the most competitive prices; and

WHEREAS State term schedules and multiple award contracts are used by the State of Ohio to provide increased flexibility in procurement while ensuring the lowest possible prices:

NOW THEREFORE

BE IT RESOLVED, That the Board of Trustees hereby revises the policy on purchasing policy to include the following provisions, effective immediately:

UPDATING OF PURCHASING POLICY (contd)

The President and/or Senior Vice President for Business and Finance is authorized on behalf of the University, on a continuing basis, to purchase without competitive bidding, equipment, materials, supplies, or services through participation in State of Ohio term schedules in which the vendor guarantees that the State will receive the lowest price as offered to the Federal government and in which the vendor agrees to accept all of the State's terms and conditions.

For any contract authorized by the University's policy on purchasing, the University is authorized to make multiple awards as provided for in the University's requests for bids or proposals.

(See Appendix XXXI for background information, page 915.)

SECOND QUARTER BUDGET REPORT

Resolution No. 2002-98

FISCAL YEAR 2001-02

Synopsis: The second quarter budget report for fiscal year 2001-02 is being submitted for adoption.

WHEREAS the University's enrollments for summer, autumn and winter quarters are now known, allowing for a more accurate picture of the University's student fee revenue; and

WHEREAS other revenues such as indirect cost recoveries on sponsored programs have been projected higher than originally budgeted; and

WHEREAS appropriate planning and consultation within the University has been accomplished and the President now recommends approval of the second quarter budget report:

NOW THEREFORE

BE IT RESOLVED, That the appropriate resources budgets be adjusted to reflect these changes as of the second quarter as described in the attached materials; and

BE IT FURTHER RESOLVED, That spending of any additional resources is frozen until a balanced budget plan is approved for FY 2002-03.

(See Appendix XXXII for background information, page 917.)

STAFF SEVERANCE PROGRAMS

Resolution No. 2002-99

Synopsis: Approval of the University and University Health System Staff Severance Programs are proposed.

WHEREAS the Board of Trustees of The Ohio State University is vested with authority, pursuant to O.R.C. section 3335.09, to adopt bylaws, rules and regulations governing the operations of the University, including but not limited to, fixing of compensation for employees of The Ohio State University; and

STAFF SEVERANCE PROGRAMS (contd)

WHEREAS the Office of Human Resources has promulgated a policy to institute staff severance programs for the University, and separately for the University Health System, which will provide for a severance program for those regular staff who are involuntarily terminated due to reduction in force or through involuntary job abolishment; excepting those employees who are terminated for performance or other appropriate reason; and

WHEREAS this policy of the Office of Human Resources has been internally approved by appropriate management committees of the University:

NOW THEREFORE

BE IT RESOLVED, That the Board of Trustees, hereby adopts this University Staff Severance Program, as described in Attachment A, and this University Health System Severance Program, as described in Attachment B, and as fully described in the Office of Human Resources Policy 2.40, and the University Health System Policy XXX, to be effective immediately.

(See Appendix XXXIII for background information, page 923.)

Upon motion of Mr. Patterson, seconded by Mr. Sofia, the Board of Trustees adopted the foregoing resolutions by unanimous roll call vote, cast by Messrs. Brennan, Patterson, Sofia, Slane, McFerson, and Judge Duncan, Mses. Longaberger, Hendricks, and Davidson.

--0--

Dr. William J. Napier:

Mr. Chairman and members of the Board, I would like to present the following resolution on the Appointment and Reappointment of Investment Managers.

APPOINTMENT AND REAPPOINTMENT OF INVESTMENT MANAGERS

Resolution No. 2002-100

Synopsis: Approval of the appointment and reappointment of investment managers is proposed.

WHEREAS it is the policy of The Ohio State University to utilize the service of external investment managers to assist in the management of the University's Endowment Fund; and

WHEREAS the Investments Committee of the Board of Trustees periodically reviews the results obtained by the external investment managers and the amount of funds assigned to each of them; and

WHEREAS it is prudent investment policy to adjust the mix and amounts of money assigned to external investment managers as economic conditions and performance change; and

WHEREAS the number of external investment managers and the amount of funds assigned to them shall be determined by the Board of Trustees:

NOW THEREFORE

BE IT RESOLVED, That upon the recommendation of the Investments Committee, the following named external investment managers and the Office of the Treasurer shall be approved to manage Endowment Funds as follows:

APPOINTMENT AND REAPPOINTMENT OF INVESTMENT MANAGERS (contd)

<u>Large Cap Equity Managers</u>	Market Value/ Commitment As of 1/31/02	Changes	Revised Allocation
ABN AMRO	\$57,543,801	\$(15,000,000)	\$42,543,801
Barclays S&P 500	235,803,528	(25,000,000)	210,803,528
Barclays Value Index	--0--	25,000,000	25,000,000
Nicholas Applegate Mid Cap	110,294,088	(20,000,000)	90,294,088
University Students	17,013,780	--0--	17,013,780
<u>Small Cap Equity Managers</u>			
Barclays Extended	\$146,421,210	\$ --0--	\$146,421,210
Meeder Financial	76,665,295	10,000,000	86,665,295
Nicholas Applegate Small Cap	26,789,358	--0--	26,789,358
<u>International Equity Managers</u>			
Barclays International	\$ 23,344,429	\$15,000,000	\$ 38,344,429
Invesco Global Asset	18,733,785	--0--	18,733,785
Sit International	13,326,841	--0--	13,326,841
<u>Fixed Income Managers</u>			
Banc One	\$ 26,037,240	\$ --0--	\$ 26,037,240
Commonfund	35,177,521	(35,177,521)	--0--
Cypress Asset Management	24,544,450	--0--	24,544,450
Hughes Capital Management	15,497,518	--0--	15,497,518
Huntington Trust	26,247,198	5,000,000	31,247,198
MDL Capital Management	79,544,180	--0--	79,544,180
<u>Alternative Managers</u>			
Battelle Technology Fund	\$ 2,625,000	\$ --0--	\$ 2,625,000
CID Seed Fund	1,000,000	--0--	1,000,000
Commonfund New Leaders	10,000,000	--0--	10,000,000

APPOINTMENT AND REAPPOINTMENT OF INVESTMENT MANAGERS (contd)

<u>Alternative Managers (contd)</u>	<u>Market Value/ Commitment As of 1/31/02</u>	<u>Changes</u>	<u>Revised Allocation</u>
Commonfund Capital Partners	\$ 7,067,000	\$ --0--	\$ 7,067,000
Commonfund High Yield Bonds	--0--	15,000,000	15,000,000
EDF Ventures Seed Fund	1,000,000	--0--	1,000,000
Mesirow Partnership Fund I	10,000,000	--0--	10,000,000

Upon motion of Mr. Slane, seconded by Ms. Hendricks, the Board of Trustees adopted the foregoing resolution with eight affirmative votes cast by Messrs. Brennan, Sofia, Slane, McFerson, and Judge Duncan, Meses. Longaberger, Hendricks, and Davidson, and one abstention cast by Mr. Patterson.

--0--

Thereupon the Board adjourned to meet Friday, April 5, 2002, at The Ohio State University Longaberger Alumni House, Columbus, Ohio.

Attest:

William J. Napier
Secretary

David L. Brennan
Chairman

(APPENDIX XXVI)

Recommendations Regarding
Funding Strategy for
The Ohio State University Columbus Campus

The Ohio State University
Board of Trustees Meeting
March 1, 2002

Office of Academic Affairs
Office of Business and Finance
February 27, 2002

Summary of February 1, 2002 Board Discussion

1. Ohio State University cannot be an engine of growth for the State of Ohio without adequate resources.
2. Our resource gap for FY 2003 is \$73 million, of which \$36 million will be made up from program cuts and reallocations. \$20 million in budget cuts are from the following:
 - Colleges - \$9 million
 - Support units - \$7 million
 - Central investments - \$4 million
3. Our recommended tuition increases included \$24 million in planned increases for current students and \$11 million in additional increase for new undergraduate students through a \$1,200 differential.
4. Need based financial aid will be increased to assure access.
5. Other funding priorities include compensation to retain qualified faculty and staff, as well as other improvements in the quality of the undergraduate experience both inside and outside the classroom.
6. Even after these increases, tuition for OSU students would still be in the middle range when compared to other selective admission public institutions in Ohio and outside of Ohio.

March 1 Recommendations

For all undergraduates (new and continuing) there would be a 9% increase in instructional and general fees beginning Summer Quarter 2002. This will amount to a \$429 increase from \$4,788 to \$5,217 for full-time undergraduates over a three quarter (academic year) period.

For new students, there would be an additional \$158 per quarter (\$474 per three quarter academic year) increase in the instructional fee above the 9% beginning Summer Quarter 2002 for a total increase of 18.9%.

New student means any undergraduate starting at Ohio State (Columbus or Regional Campus) Summer Quarter 2002 or later. Continuing student means any undergraduate starting at Ohio State (Columbus or Regional Campus) prior to Summer Quarter 2002.

Current students would be grandfathered (exempted) from the higher differential rates applied to new students for four years (through FY 2006).

Additional differential rate increases for new students will be phased in over the next two or three years in order to achieve our academic goals.

These recommendations apply to Columbus Campus only. Recommendations for regional campuses will be determined after they have had a chance to consult with their advisory boards.

Increased student financial aid funds will assure that students who are otherwise qualified will be afforded access.

These recommendations are based on existing levels of state support. If those levels change, recommendations may have to be modified.

An additional \$6 million will be identified through a combination of additional targeted spending reductions, reallocations, redirection and revenue increases.

Size of the Problem

To meet the FY 2003 programmatic goals outlined in the February 1 plan, approximately \$73 million had to be identified.

The modification of the differential for new students from \$1,200 annually to \$474 annually results in a corresponding reduction of \$2 million needed for financial aid. Thus, OSU now needs to identify \$71 million in resources for the Columbus Campus. The recommended sources are as follows:

Cuts previously planned	\$20M
Previously planned reallocations and other revenue	\$16M
Previously planned tuition increases 9% undergraduate students 5% graduate and professional students	\$24M
Additional increases on new undergraduate students +\$474	<u>\$5M</u>
Total	\$65M

Amount still needed to achieve the \$71 million target ($\$71M - 65M$) = \$6M

Additional Cuts Not Recommended

Additional programmatic cuts to college and support units are not recommended because the University and the community will already feel the adverse impact of the \$20 million in hard cuts and up to an additional \$16 million in reallocations and redirections:

Category	Percent Target	*Dollar Target	Positions Lost
Colleges	5.0%	\$18.8M	241
Support Units	7.0%	\$13.9M	185
Central Programs	10.0%	<u>\$4.0M</u>	<u>0</u>
Total		\$36.7M	426

Summary of positions eliminated by category (Columbus Campus Only)

Vacant	248
Filled	51
Other (GAs, Temporary and Intermittent)	<u>127</u>
	426
Faculty	85
Staff	214
Other (GAs, Temporary and Intermittent)	<u>127</u>
	426

* Represents percentage of Present Budget Authority needed for budget reductions (2.5% for colleges; 3.5% for support areas) and an equivalent amount to be used for compensation. Does not include total redirection dollars necessary to reach compensation targets. Does not include regional campuses or College of Medicine and Public Health.

How will the remaining gap be closed?

Preliminary Proposed Modifications:

Revenue from increased Winter Quarter enrollments	\$1.0M
Implementation of all tuition increases Summer Quarter	0.7
Additional increase in non-resident surcharge	0.5
Charge regional campuses for courses taught to their students on the Columbus Campus	0.4
Redirect more of unrestricted gift money to General Fund scholarships	<u>1.0</u>
	3.6M
Still to be determined	<u>2.4</u>
	\$6.0M

NOTE: These numbers are preliminary and subject to change. A balanced budget for FY 2003 will be presented prior to June 30th.

Implications

- A. Progress on academic goals will be maintained, but at a slower pace than anticipated in the December 2000 Academic Plan and the February 1 proposal.
- B. These recommendations mean that planned and additional tuition increases will contribute no more than \$30 million to the FY 2003 solution of a \$71 million problem.
- C. Access for academically qualified students will be maintained.
- D. Students will benefit directly.
- E. OSU will remain a unique combination of excellence and affordability.
- F. Achieving these goals is dependent on maintaining existing levels of state support for FY 2002 and FY 2003.

- G. Significant resource gaps remain that need to be addressed in FY 2004 and beyond; this will require additional differential increases on new students for the next two or three years until tuition at Ohio State is commensurate with its mission and its role as the state's flagship university and it has the resources necessary to achieve the goals of the Academic Plan.

OSU will remain affordable

Ohio State will remain affordable compared to other public universities, even if those universities increase FY 2003 tuition by a smaller percentage amount.

For example, if other Ohio universities increase tuition by amounts already announced and by 6% for those who have not yet announced OSU will rank:

8th out of 13 on tuition for current students, and
6th out of 13 for new students

If other Big Ten universities raise tuition by the amount already announced and by 10% for those who have not yet announced, OSU will rank:

6th out of 10 for current students, and
6th out of 10 for new students.

If other Benchmark universities raise tuition by 10%, or the amount already announced, OSU will rank:

5th out of 10 for current students, and
5th out of 10 for new students.

What Happens Next?

March	Vote on undergraduate tuition levels for the Columbus Campus
April	Discussion of compensation goals Discussion of regional campus tuition goals
May	Vote on compensation plan
June	Vote on all other tuition and fees
July	Vote on complete budget package

Summary

1. A principled commitment to continue to improve the University's academic standing is critical to our students' future and the future of Ohio.
2. This commitment must be pursued despite historically weak state support and weakness in the state's economy.
3. The University has taken significant steps to achieve cost efficiencies and to increase revenue from other sources.
4. Nevertheless, a significant increase is needed in tuition for the FY 2003 academic year in order to preserve progress already made and to make additional progress.
5. The strategy recommended will limit the burden on current students.
6. Financial aid funds will be increased for all students (including new students) so students who are otherwise qualified will not be denied admission for financial reasons.
7. Even after the proposed increases, the University's tuition still will not exceed the mid-point of Big Ten public universities or the tuition of any of Ohio's other public universities with selective admissions.
8. The additional funds will be used to preserve gains already made by providing market level compensation to faculty and staff and to continue to make improvements in student life both inside and outside the classroom, which is critical to the success of the Academic Plan.
9. Achievement of these goals is based on the assumption that state support will be maintained at current levels for FY 2002 and FY 2003.
10. Significant resource issues remain to be addressed in FY 2004 and beyond. This will require additional differential increases for new students in future years so that the goals of the Academic Plan can be achieved.
11. The Ohio State University will continue to be a great investment for our students and for the people of Ohio.

(APPENDIX XXVII)

ENDOWMENT INVESTMENTS POLICY

SUMMARY

As discussed in Investments Committee, we request the Endowment Fund Investments Policy be modified to adjust asset allocation ranges and targets, and certain dollar limitations of authorized investments. The asset allocation ranges have been widened to allow for market fluctuations. The target for alternative investments has been increased from 8% to 13%. The target for U.S. Large-Cap Stocks has decreased from 45% to 40%.

Dollar limitations of investment in individual companies/entities has been increased from: \$3 million to \$5 million for Commercial Paper, Banker's Acceptances, Eurodollar CD's and Time Deposits, Municipal Bonds, and Collateralized Mortgage Obligations; and from \$1 million to \$3 million for Guaranteed Investment Contracts and Asset Backed Securities.

ENDOWMENT FUND INVESTMENTS POLICY

I. Goal

It shall be the policy of The Ohio State University to manage the Endowment Fund for the use and benefit of the University in a manner that will preserve and maintain the real purchasing power of the principal in a diversified portfolio while allowing for an annual distribution of income according to this policy.

II. Investment Philosophy

The Endowment fund shall be managed with the intention of obtaining the highest possible "total return" (i.e., current income plus net realized and unrealized appreciation) of the investment portfolio, balancing reasonable growth with maintenance of prudently acceptable risk.

III. Limitations

A. The Endowment Fund will have an asset allocation range and a target allocation as follows:

	RANGE	TARGET ALLOCATION
U.S. LARGE CAP STOCKS	30% TO 50%	40%
U.S. SMALL CAP STOCKS	15% TO 35%	25%
INTERNATIONAL STOCKS	5% TO 10%	7%
FIXED INCOME	10% TO 25%	15%
ALTERNATIVE INVESTMENTS	5% TO 20%	13%
CASH	0% TO 10%	0%
TOTAL ENDOWMENT		100%

- B. For purposes of these limitations, the amounts recommended to be maintained in short-term Investments by the investment advisors shall be considered as invested in their asset class.
- C. New money received by the Endowment may be placed by the Treasurer in Index funds in amounts to maintain the Investment Limitations aforementioned until such time as the Board of Trustees reallocates such funds.
- D. The Treasurer may specify terms and conditions that are more restrictive than those of this Policy but shall not permit a less restrictive policy without specific authorization from The Board of Trustees.
- E. The quality rating guidelines which are to be used shall be the ratings as of the date of the purchase of the security. If a rating change occurs which disqualifies a security that is already present in the portfolio, the security must be sold within ninety days from the discovery of the rating change.

IV. Gains/Losses

- A. It shall be permissible for the Treasurer to realize gains and losses in the portfolio if such an action would be consistent with the University's investment goals.
- B. In order to maintain the purchasing power of the endowment as well as maintain an orderly distribution of income under the Endowment Fund's spending policy, a stabilization reserve account shall be maintained. The stabilization reserve account shall be used to account for any excess (deficit) of income earned versus monies distributed to the endowment funds.

V. Income Distribution Policy

Income will be distributed to Endowment Funds at the beginning of each fiscal year according to a formula based upon a distribution of 5.0% of the average market value of the portfolio over the most recent three years. New monies placed in the Endowment Fund will receive an income distribution prorated by the month of the fiscal year received.

VI. Advisors

The University may utilize the services of external investment advisors to assist in the management of the endowment. The responsibilities and types of investment services provided by investment advisors shall be specified in written agreements. The investment advisors appointed by the Board of Trustees will invest the assets in accordance with this policy, their written agreement and their judgements concerning relative investment values. The Board may appoint an advisor with specific authority to invest in assets not otherwise addressed in this policy. The investment advisors are accorded full discretion, within policy limits, to select individual securities, and diversify the assets. The number of advisors and the amount of funds under each advisors aegis shall be determined by the Board of Trustees.

Advisors performance will be measured against an appropriate benchmark. Passive managers are expected to equal the benchmark while active managers are expected to exceed the benchmark net of fees.

VII. Marketability

Securities purchased by the endowment shall be listed on the New York, American or other exchange or be unlisted and traded over-the-counter provided that all securities purchased shall be readily marketable and meet the quality guidelines of this Policy. Real estate purchases will be based on investment merit. Real Estate and Private Equities must undergo periodic appraisals by a qualified third party appraiser. Investments that have no ready market that are gifts to the University shall only be accepted if, as determined by the Treasurer, acceptance is in the best interest of the University.

VIII. Proxies

The Treasurer has the authority to vote proxies in accordance with the proxy policy approved by the Investments Committee of the Board of Trustees.

IX. Authorized Investments

The following categories of investments shall be authorized for the endowment:

- A. Commercial Paper

1. Rated A-1 (Standard and Poor's) and P-1 (Moody's), not more than \$5,000,000 in any corporation or financial institution.

2. Commercial paper must have a term less than 270 days.

B. Banker's Acceptances

1. An amount not to exceed \$5,000,000 in any bank, or subsidiaries of that bank whose long-term debt is rated A or better.

2. Banker's acceptances must have a term less than 270 days.

C. Eurodollar CD and time deposits

1. An amount not to exceed \$5,000,000 in any bank, or subsidiaries of that bank with a long-term debt rating of BBB or better.

2. Eurodollars shall have a term less than one year.

D. Corporate Bonds and Notes

1. No bond or note shall be purchased in an amount greater than \$5,000,000 par value of any corporation.

2. Bonds and notes shall be rated BBB or better.

3. Corporate bonds or notes shall have a term less than 40 years.

4. Foreign Bonds may be purchased provided they comply with items 1 thru 3 of this section and are denominated in U.S. dollars.

E. Common Stock and Preferred Stock

An amount not to exceed 3% of the outstanding shares of a company may be purchased. All stock shall be of investment grade.

F. Mutual and Commingled Funds

Investment in any fund shall not exceed 10% of the total funds of the mutual or commingled fund. All mutual or commingled funds shall comply with the Authorized Investment provisions of this policy (see Section IX). Money market mutual funds shall not apply to this section (see Section N).

G. Municipal or State Bonds

1. An amount not to exceed \$5,000,000 in any one municipality or state (except that there shall be no limit on Ohio State University or Ohio State University-related bonds).

2. Bonds shall be rated BBB or better (except that there shall be no rating requirement on Ohio State University or Ohio State University-related bonds).

3. No bonds shall be purchased with a term greater than 40 years.

H. Certificates of Deposit

1. Collateralized at market value

Not to exceed \$5,000,000 in any bank or savings and loan whose long-term debt is rated A or better provided the amount not federally insured is collateralized as provided in Section 135.18 of the Ohio Revised Code with securities eligible under Section 135.18 (B).

2. Certificate of deposit shall have a term not exceeding one year.

I. U.S. Treasury Bills, Notes and Bonds

No limitations on amount invested or term.

J. U.S. Government Agencies

No limitations on amount invested or term.

K. Repurchase Agreements

Not to exceed \$10,000,000 with any dealer or broker recognized by the Federal Reserve as a primary dealer or any bank whose long-term debt is rated A or better and only provided a written repurchase agreement is in place. The term of any agreement shall not exceed 15 days. Collateral must be U.S. government or agency securities at 102% or more of market value. Collateral must be segregated in an account bearing the University's name, except when there already exists a demand deposit account.

L. Reverse Repurchase Agreements

Not to exceed \$10,000,000 with any dealer or broker recognized by the federal reserve as a primary dealer or any bank whose long term debt is rated A or better or only provided a written agreement is in place. The term of any agreement shall not exceed 15 days.

M. Money Market Mutual Funds

1. Government collateralized

There shall be no limitations on the amount invested provided it is 100% collateralized at market value by U.S. government or agency securities.

2. Other collateral

There shall be no limitations on the amount invested provided it is 100% collateralized by marketable securities that comply with all other provisions set forth in this policy.

N. Guaranteed Investment Contracts (GIC)

1. An amount not to exceed \$3,000,000 can be placed with any insurance company with assets in excess of \$5 billion and a long-term debt rating of A or better.

2. GIC's must be 100% collateralized with U.S. treasuries, agencies or corporate bonds rated A or better.
3. No GIC shall be purchased with an expected life greater than 5 years.

O. Collateralized Mortgage Obligations (CMO)

1. An amount not to exceed \$5,000,000 may be invested in any one issuer.
2. CMO's must be rated AAA.
3. No CMO shall be purchased with an expected life greater than 30 years.

P. Asset Backed Securities (ABS)

1. An amount not to exceed \$3,000,000 may be invested in any one issuer.
2. ABS's must be rated AAA.
3. No ABS shall be purchased with an expected life greater than 5 years.

Q. Securities Lending

Equity and Fixed Income securities not to exceed 30% of the Endowment may be Loaned on condition the loan is secured. Collateral must be cash or U.S. Government Agency securities at 102% or more market value. Lending may be done with any dealer or broker recognized by the Federal Reserve of a primary dealer or any bank whose long term debt rating is A or better and only provided a written agreement is in place.

R. Alternative Investments

Alternative investments may be made only by a professional investment advisor (See Article VI.) unless specifically authorized by the Board of Trustees.

S. Other Investments

Between meetings of the Board of Trustees, if deemed advisable, other investments not specifically authorized by this Policy may be made if approved by the Investments Committee of the Board of Trustees. Any such action shall be taken to the Board of Trustees for approval at its next meeting.

X. Management of Investments

Except as provided herein, the Treasurer shall be authorized to implement and administer this Policy on behalf of the Board of Trustees and manage the endowment in accordance with this Policy.

XI. Exceptions

Modifications and exceptions to this Policy shall be authorized only by resolution of the Board of Trustees or as provided herein. The terms and conditions of this Policy as to the endowment portfolio may be waived if specified by the terms of a gift and approved by the Board of Trustees.

XII. Reporting and Accountability

The Treasurer shall be accountable to the Board of Trustees for implementing this Policy. The Treasurer shall make a written report to the Investments Committee at each regular meeting on the status of the Endowment Fund.

XIII. Support Level Required to Establish an Endowment Fund

- A. A *Named Endowed Chair* will be established in the Endowment with support of \$1,500,000 or more and the distributed income will be used to provide supplemental compensation and academic support funds for chairholder.
- B. A *Named Endowed Professorship* will be established in the Endowment with support of \$750,000 or more and the distributed income will be used to provide supplemental compensation and academic support for faculty member.
- C. A *Named Endowed Distinguished Visitor* will be established in the Endowment with support of \$500,000 or more and the distributed income will be used to provide funds to bring a distinguished visitor to the University for a limited time, generally from one week to one year. This category of endowed faculty funds may be used for distinguished scholars, teachers, lecturers, research investigators, artists, writers, executives-in-residence, or others in association with activities that advance the academic, interdisciplinary, diversity, and other educational goals of the University, its colleges and programs.
- D. A *Named Endowed Faculty Award* will be established in the Endowment with Support of \$250,000 or more and the distributed income will be used to provide funds to recruit or retain outstanding faculty and provide them with academic support funds to enhance their work. Also designed to help meet the University's diversity goals.
- E. A *Named Dean's Leadership Fund* will be established in the Endowment with support of \$100,000 or more and the distributed income will be used to provide funds to allow deans to support existing or new faculty endeavors, promote promising initiatives across or among colleges, support lecturer series, and generally promote the goals of the college.
- F. A *Named Scholarship* will be established in the Endowment with support of \$100,000 or more and the distributed income will be used to provide general University scholarships for a diverse group of students according to financial need as determined by federal guidelines, or provides scholarship assistance for students based on performance (i.e., musicians, artists, dancers, athletes, etc.), and for minority students.
- G. A *Named Graduate Fellowship* will be established in the Endowment with support of \$250,000 or more and the distributed income will be used to provide funds for a diverse group of outstanding graduate and professional students including minority students based on criteria established by colleges and departments.
- H. A *University Scholar Merit Scholarship* will be established in the Endowment with support of \$25,000 or more and the distributed income will be used to provide \$1,000 to incoming students who graduated at the top of their high school class and who have high test scores.
- I. A *Medalist Scholar Merit Scholarship* will be established in the Endowment with support of \$75,000 or more and the distributed income will be used to provide in-state tuition awards for 30 incoming students who score among the best in and on campus competition.

- J. A *Distinguished Scholar Merit Scholarship* will be established in the Endowment with support of \$150,000 or more and the distributed income will be used to provide awards of in-state tuition and a stipend toward room and board for qualifying National Merit and National Achievement Scholars.
- K. A *Presidential Scholar Merit Scholarship* will be established in the Endowment with support of \$250,000 or more and the distributed income will be used to provide an in-state full-ride award for ten incoming students who score at the very top in and on-campus competition.
- L. A *Named Endowed Fund* will be established in the Endowment with support of \$25,000 or more and the distributed income will be used to provide an enduring memorial to the donor and bear the donor's name or an appropriate name of the donor's designation. The fund will be invested and the income used to provide support for a program designated by the donor and approved by the University.

**Waivers of Competitive Bidding Requirements
October-December 2001**

<u>Category</u>	<u>Total</u>		<u>Sole Source</u>		<u>Emergency</u>		<u>Sufficient Economic Reason</u>	
Hospitals - Professional Health Care Services	\$8,898,634	12	\$5,214,508	2	\$1,350,000	1	\$2,334,126	9
Hospitals - Equipment and Services	\$3,353,836	18	\$2,135,115	12	\$120,000	1	\$1,098,721	5
Merchandise for Resale	\$60,000	1	\$60,000	1	\$0	0	\$0	0
Instructional and Research Equipment and Services	\$2,460,248	20	\$1,819,206	10	\$0	0	\$641,042	10
Administrative Support Equipment and Services	\$1,920,970	17	\$689,697	6	\$630,064	7	\$601,209	4
Conference Facilities	\$52,874	1	\$52,874	1	\$0	0	\$0	0
TOTAL	\$16,746,562	69	\$9,971,400	32	\$2,100,064	9	\$4,675,098	28

(APPENDIX XXVIII)

898

Report on Waivers of Competitive Bidding Requirements: October-December 2001

Category and Waiver Description	Total		Sole Source		Emergency		Sufficient Econ. Reason	
Hospitals - Professional Health Care Services	\$8,898,634	12	\$5,214,508	2	\$1,350,000	1	\$2,334,126	9
Physician services - Ohio Dept of Rehab. & Correction	\$5,214,508	2	\$5,214,508	2				
Nursing services - HPO Staffing Inc.	\$1,350,000	1			\$1,350,000	1		
Physician services - Univ. Psychiatric Physicians	\$1,030,407	2					\$1,030,407	2
Prof billing and collection services - Univ. Physician Systems	\$496,000	2					\$496,000	2
Physician fees - Family Medicine Foundation	\$450,000	1					\$450,000	1
Physician services - OSU Sports Medicine Physicians	\$195,198	3					\$195,198	3
Pathology services - University Pathology Services Inc.	\$162,521	1					\$162,521	1
Hospitals - Equipment and Services	\$3,353,836	18	\$2,135,115	12	\$120,000	1	\$1,098,721	5
Heart Hospital Generator Equipment	\$806,500	1	\$806,500	1				
Firestopping - for walls throughout Hospital	\$699,850	1					\$699,850	1
Robotic surgical system support services	\$200,000	2	\$200,000	2				
Consulting services - Automated Guided Vehicle System	\$191,840	1	\$191,840	1				
Software license & hardware/software upgrade	\$184,730	1	\$184,730	1				
Blood lancets for Blood Glucose Program	\$170,100	1					\$170,100	1
Heart/lung pump equipment for surgery	\$120,036	1	\$120,036	1				
IDX user fees- Management services	\$120,000	1					\$120,000	1
Printer maintenance, service and toner	\$120,000	1			\$120,000	1		
Monthly transaction fees for HDX system	\$120,000	1	\$120,000	1				
Clinical information system	\$107,826	1	\$107,826	1				
Breast biopsy accessories	\$105,580	1	\$105,580	1				
Reference lab testing	\$105,000	1	\$105,000	1				
Cardiac rehab and stress testing	\$78,000	1					\$78,000	1
VAD blood pumps	\$69,130	1	\$69,130	1				
Disposable heart implant system	\$68,250	1	\$68,250	1				
Client server upgrade - Treatment Planning System	\$56,223	1	\$56,223	1				
Mobile C-Arm X-Ray unit - Radiation equipment	\$30,771	1					\$30,771	1

006

Report on Waivers of Competitive Bidding Requirements: October-December 2001

Category and Waiver Description	Total		Sole Source		Emergency		Sufficient Econ. Reason	
Merchandise For Resale	\$60,000	1	\$60,000	1	\$0	0	\$0	0
Food for restaurant - University Golf Course	\$60,000	1	\$60,000	1				
Instructional & Research Equipment & Services	\$2,460,248	20	\$1,819,206	10	\$0	0	\$641,042	10
Program acquisition for radio/ tv broadcast - WOSU Stations	\$973,731	2	\$973,731	2				
Lab Equipment - Ohio Micro MD Lab	\$475,450	1	\$475,450	1				
Benchmark staining system - Pathology	\$100,000	1	\$100,000	1				
Probe arrays/reagents - Human & Cancer Genetics	\$100,000	1					\$100,000	1
Network installation and testing - Veterinary Med Administration	\$99,149	1					\$99,149	1
Telephone Equipment - Center for Human Resource Research	\$96,278	2					\$96,278	2
Cessna aircraft 172P - University Airport	\$79,000	1					\$79,000	1
Network branch exchange - Center/Human Resource Research	\$71,523	1					\$71,523	1
Postbox e-mail conversion/final phase - OIT Enterprise Networking	\$65,100	1					\$65,100	1
Catering sevices - Civil, Environmental Engineering & Geodetic Science	\$61,433	1	\$61,433	1				
Trimble GPS receiver - Civil , Environmental Engineering & Geodetic Science	\$60,000	1					\$60,000	1
Educational training service - Marion Campus	\$55,386	1	\$55,386	1				
Modulated DSC system - Dentistry Equipment	\$80,420	2	\$54,000	1			\$26,420	1
Sevice agreement for fit out of lab - Ohio MicroMD Lab	\$43,572	1					\$43,572	1
DNA amplification system - Molecular Vir, Imm & Med Gen	\$37,480	1	\$37,480	1				
Microplate reader combination system - Surgery	\$34,840	1	\$34,840	1				
Custom design/building of trailer - OARDC Horticulture & Crop Science	\$26,886	1	\$26,886	1				
Administrative Support Equipment & Services	\$1,920,970	17	\$689,697	6	\$630,064	7	\$601,209	4
Software - High Performance Computing - Ohio Supercomputer Center	\$629,000	3	\$79,000	1			\$550,000	2
Temporary custodial services - Contract Services	\$372,899	3			\$372,899	3		
Support for COMIT telecommunications system - UNITS	\$358,585	1	\$358,585	1				
Officiating fees and expenses - Athletics	\$157,970	2	\$157,970	2				
Charter services - Athletics	\$129,862	1			\$129,862	1		
Consulting Services - Physical Facilities	\$94,142	2	\$94,142	2				
Catering Services - Commencement & Official Events Operation	\$91,403	2			\$91,403	2		
Shuttle bus - Transportation and Parking Services	\$35,900	1			\$35,900	1		
Furniture - Student Affairs	\$26,079	1					\$26,079	1
Computer equipment - Buck ID	\$25,130	1					\$25,130	1

106

Report on Waivers of Competitive Bidding Requirements: October-December 2001

Category and Waiver Description	Total		Sole Source		Emergency		Sufficient Econ. Reason	
Conference Facilities	\$52,874	1	\$52,874	1	\$0	0	\$0	0
Reading Recovery Fall Institute - Hyatt on Capitol Square	\$52,874	1	\$52,874	1				
TOTAL	\$16,746,562	69	\$9,971,400	32	\$2,100,064	9	\$4,675,098	28

Heart Hospital**315-1999-939****PROJECT CAPTAIN:**

Lori Seeger, Facilities Planning & Development - Architecture, 688-3757

REQUESTING AGENCY:

Office of Health Sciences

PROJECT LOCATION:

V0010-Site - See Comments.

AGE:

N/A

GR. SQ. FT.:

N/A

PROJECT DESCRIPTION:

This project will construct a new heart hospital to house an integrated cardiothoracic surgery and cardiology program. The facility will include inpatient services, surgical services, diagnostic and treatment services, outpatient clinic, clinical support staff area, administrative support, and cardiac rehabilitation services space.

MILESTONES:

	Projected	Revised	Actual
Arch/Eng Approved B/T	7/7/2000		7/7/2000
Constr Mgr Approved B/T	2/2/2001		2/2/2001
Bidding Approved B/T	12/1/2000	3/1/2002	
Arch/Engr Contract	2/15/2001	1/2/2002	12/19/2001
Schematic Design Approval	6/20/2001	1/2/2002	2/4/2002
Design Development Approval	10/30/2001	4/15/2002	
Construction Document Approval	1/1/2001	10/10/2002	
Bid Opening	3/15/2001	3/8/2002	
Award of Contracts	4/18/2002	5/8/2002	
Construction Start	8/1/2002		
Report of Award to B/T	11/1/2001	2/7/2003	
Completion	3/31/2003	8/23/2004	

FUNDING INFORMATION:

Future University Bond Issues	\$ -	\$ 69,590,000.00	
HB640 Line Item Appropriation	2,610,000	2,610,000	
Development-University Hospitals	63,790,000	10,000,000	
Total	\$ 66,400,000	\$ 82,200,000	

USES:

Constr. Mgr.	\$ -	\$ 2,805,000	
Construction	37,000,000	51,000,000	
Cont. Medical	-	37,764	
Contingency	4,181,000	6,700,000	
Design	2,775,000	4,395,236	
Equipment	22,000,000	16,650,000	
Univ. Administration	444,000	612,000	
Total	\$ 66,400,000	\$ 82,200,000	

COMMENTS:

Site - Rhodes Hall Auditorium. Project is anticipated to be bid in multiple phases starting in March 2001. The milestone dates reflect the first phase start and the third phase completion. Project budget increased because of the site relocation from the Neuropsychiatric facility to a new building on the site of Rhodes Hall Auditorium which allows the building to function and operate more efficiently.

Heart Hospital

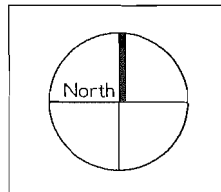
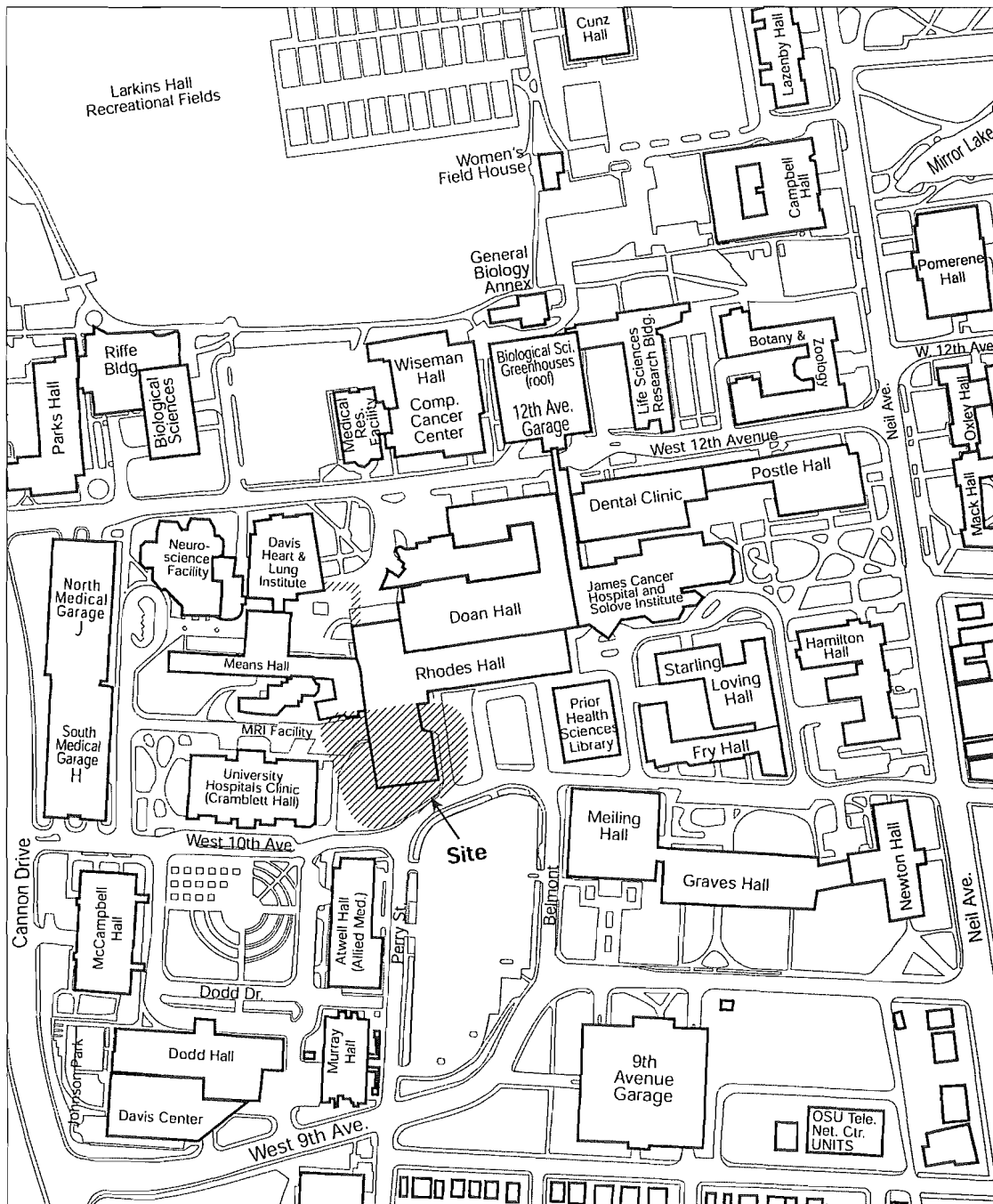

Office of Business and Finance
Office of Facilities Planning and Development

January 19, 2001

Ohio 4-H Center

315-2000-911

PROJECT CAPTAIN:

Marjory Trishman Spangler, Facilities Planning & Development - Architecture, 292-5704

REQUESTING AGENCY:

OSU Extension

PROJECT LOCATION:

V0010-Site - See Comments.

AGE:

GR. SQ. FT.:

PROJECT DESCRIPTION:

This project consists of the demolition of Dakan Hall and the planning, programming, design, FF&E, site planning and construction administration of the new Ohio 4-H Center. The new structure will include space for the OSU 4-H Youth Development staff, the OSU Extension programs, and those programs from the College of Food, Agricultural, and Environmental Sciences who will interact with 4-H. Outdoor program space, outdoor amenities, and parking is also included.

MILESTONES:

	Projected	Revised	Actual
Arch/Eng Approved B/T	3/1/2002		
Bidding Approved B/T	3/1/2002		
Arch/Engr Contract	7/1/2002		
Schematic Design Approval	9/30/2002		
Design Development Approval	11/25/2002		
Construction Document Approval	3/17/2003		
Bid Opening	5/6/2003		
Award of Contracts	6/16/2003		
Construction Start	6/16/2003		
Report of Award to B/T	8/1/2003		
Completion	7/1/2004		

FUNDING INFORMATION:

Ohio 4-H Foundation Board	\$	9,110,627	
Total	\$	9,110,627	

USES:

Construction	\$	6,628,751	
Contingency		1,126,888	
Design		596,588	
Equipment		662,875	
Moving		9,351	
Univ Administration		86,174	
Total	\$	9,110,627	

COMMENTS:

A study was made to determine whether renovating a current building or building a new facility would be the most feasible. Building to be constructed on the site north of the existing Dakan Hall.

Ohio 4-H Center

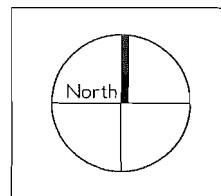
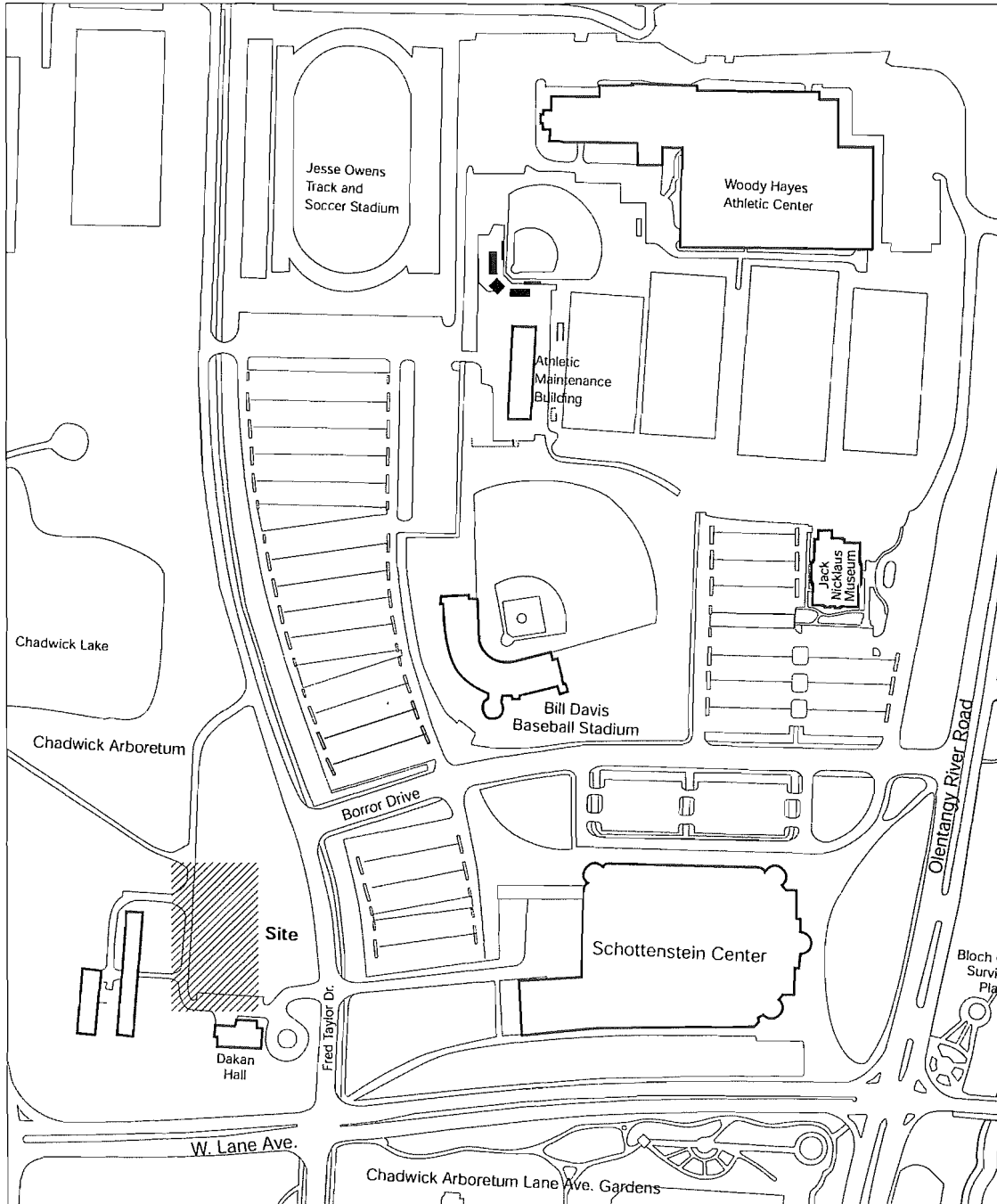

Office of Business and Finance
Office of Facilities Planning and Development

February 19, 2002

Multi-Purpose Turf Field

315-1999-188-2

PROJECT CAPTAIN:

David L. Chapman, Facilities Planning & Development - Architecture, 292-5715

REQUESTING AGENCY:

Recreation and Intramural Sports

PROJECT LOCATION:

O0000-Unidentified Mall, Plaza,Green-Col.

AGE:**GR. SQ. FT.:****PROJECT DESCRIPTION:**

Installation of a new 130 yard turf field sited on the northwest field of the Larkins four-field complex including installation of turf field lighting and filming platform. The outdoor artificial surface field will have a dual role in that it will not only be the practice field of for the marching band but it will also be scheduled for club sports through the Department of Recreational Sports. Multiple field striping overlaid on top of each other, differentiated by color, will allow the field to be used for men's and women's soccer, lacrosse and field hockey, as well as flag football. In addition, the field will also be equipped with an outdoor lighting system which will extend the use of the field significantly.

MILESTONES:

	Projected	Revised	Actual
Arch/Eng Approved B/T	3/1/2002		
Bidding Approved B/T	3/1/2002		
Construction Document Approval	2/26/2002		
Bid Opening	4/16/2002		
Award of Contracts	6/4/2002		
Construction Start	6/11/2002		
Report of Award to B/T	7/12/2002		
Completion	9/17/2002		

FUNDING INFORMATION:

Future Univ. Bond Issues	\$	264,000		
Gift Monies - Coca Cola		140,000		
Development-Business & Admin		671,000		
General Funds-Business & Admin		150,000		
Total	\$	1,225,000		

USES:

Construction	\$	1,018,010		
Contingency		114,758		
Design		79,868		
Univ. Administr		12,364		
Total	\$	1,225,000		

COMMENTS:

Multi-Purpose Turf Field

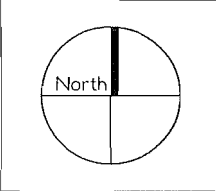
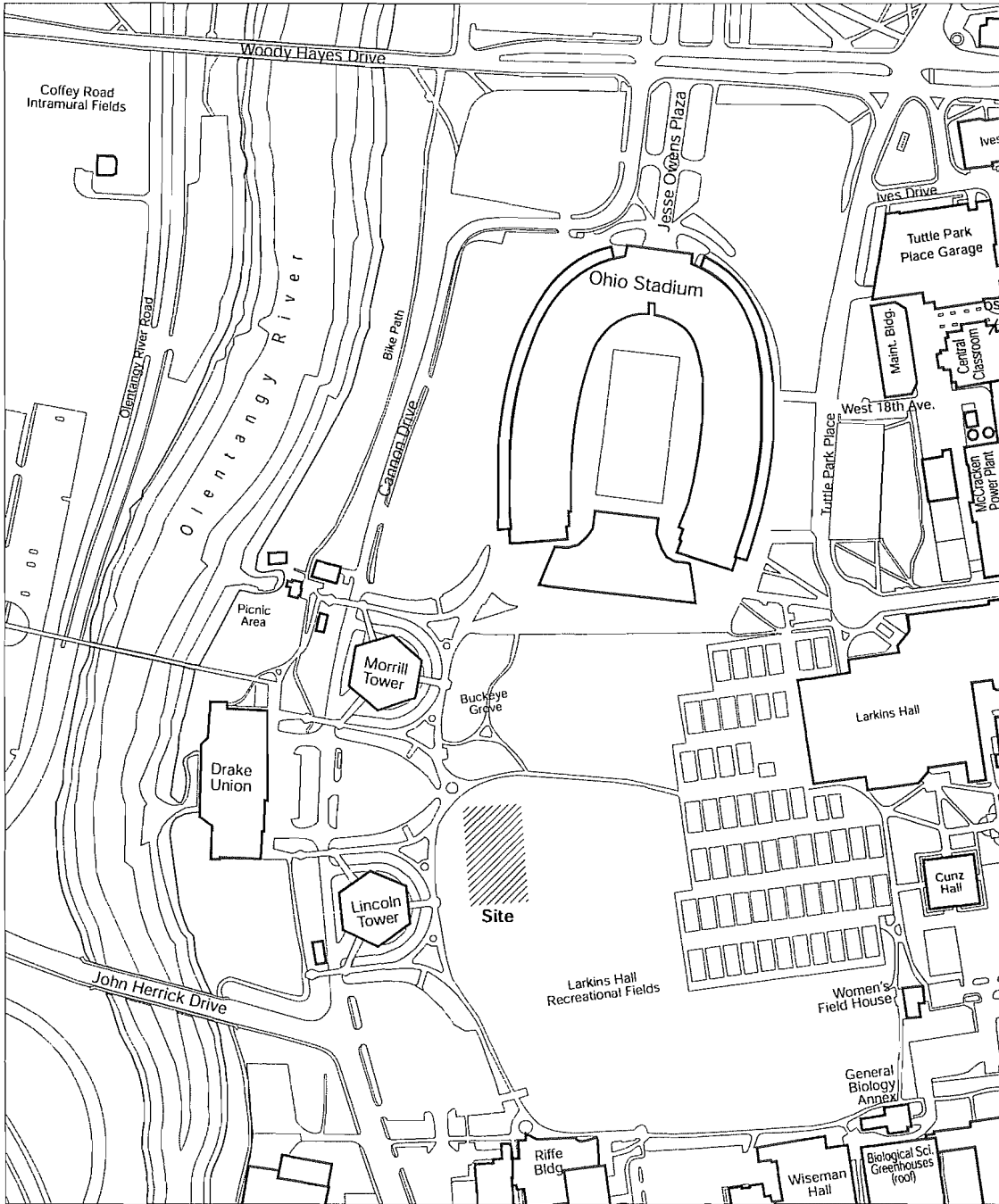

Office of Business and Finance
Office of Facilities Planning and Development

February 15, 2002

Lab Animal Facility Expansion

315-2001-932

PROJECT CAPTAIN:

Jack Bargaheiser, Facilities Planning & Development - Architecture, 247-7607

REQUESTING AGENCY:

Office of Research

PROJECT LOCATION:

0201-LABORATORY ANIMAL CENTER BUILDING 1

AGE:

1971

GR. SQ. FT.:

23,811

PROJECT DESCRIPTION:

Building #1 at the Lab Animal Facility, Godown Road was built in 1972. The building is not adequate to house animals requiring closely monitored HVAC and light requirements. The ULAR is proposing that three modular buildings be used to house animals of the LAC. Electric, water, and sewage hookups, a concrete pad, outside lighting, security hookups and a covered pathway to Building.

MILESTONES:

	Projected	Revised	Actual
Constr Mgr Approved B/T	3/1/2002		
Construction Document Approval	3/18/2002		
Construction Start	3/29/2002		
Report of Award to B/T	12/6/2002		
Completion	4/29/2002		

FUNDING INFORMATION:

General Funds-Research	\$ 500,000	\$ -	\$ -
Total	\$ 500,000	\$ -	\$ -

USES:

Construction	\$ 459,894	\$ -	\$ -
Contingency	33,476		
Univ. Administr	6,630		
Total	\$ 500,000	\$ -	\$ -

COMMENTS:

Project formerly known as 50700-R011661.

Laboratory Animal Facility Expansion

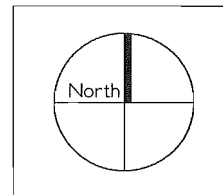
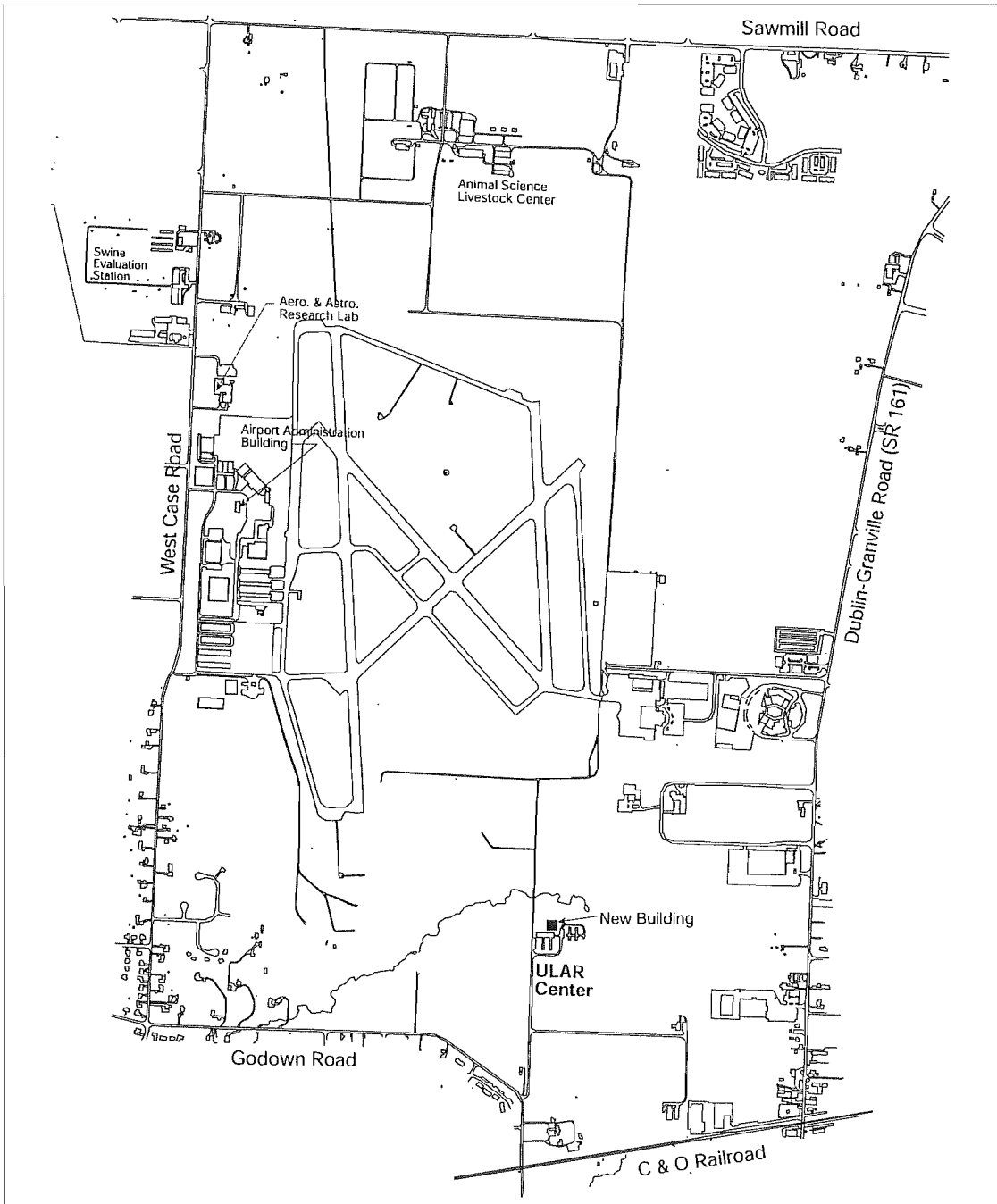

Office of Business and Finance
Office of Facilities Planning and Development

February 7, 2002

PROJECT CAPTAIN:

Marjory Trishman Spangler, Facilities Planning & Development - Architecture, 292-5704

REQUESTING AGENCY:

ATI Administration

PROJECT LOCATION:

V0008-Various Locations-ATI

AGE:

GR. SQ. FT.:

PROJECT DESCRIPTION:

Complete the exterior courtyard including landscaping. This is the final phase of the Shisler/CEED Project.

MILESTONES:	Projected	Revised	Actual
Arch/Eng Approved B/T	3/1/2002		
Bidding Approved B/T	3/2/2002		
Arch/Engr Contract	4/12/2002		
Construction Document Approval	5/17/2002		
Bid Opening	6/15/2002		
Construction Start	8/5/2002		
Report of Award to B/T	12/6/2002		
Completion	10/31/2002		

FUNDING INFORMATION:

HB640 ATI Basic-Renovations	\$ 300,000	\$ -	\$ -
Total	\$ 300,000	\$ -	\$ -

USES:

Construction	\$ 255,975	\$ -	\$ -
Contingency	24,827		
Design	15,359		
Univ. Administr	3,840		
Total	\$ 300,000	\$ -	\$ -

COMMENTS:

ATI - Shisler Center Courtyard

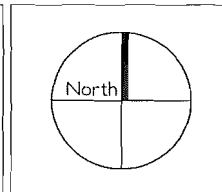
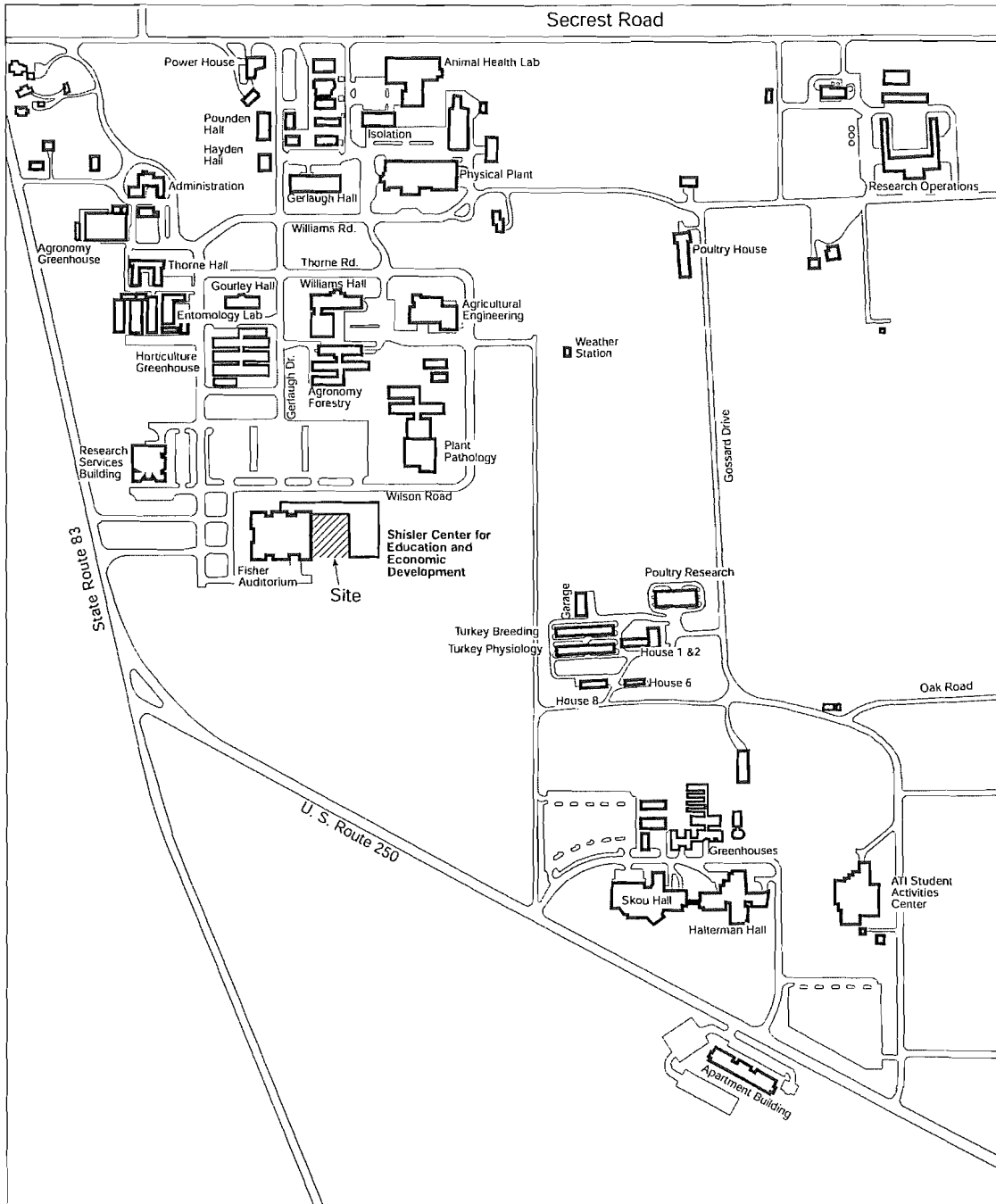

Office of Business and Finance
Office of Facilities Planning and Development

February 7, 2002

Heart Hospital**315-1999-939****PROJECT CAPTAIN:**

Lori Seeger, Facilities Planning & Development - Architecture, 688-3757

REQUESTING AGENCY:

Office of Health Sciences

PROJECT LOCATION:

V0010-Site - See Comments.

AGE:

N/A

GR. SQ. FT.:

N/A

PROJECT DESCRIPTION:

This project will construct a new heart hospital to house an integrated cardiothoracic surgery and cardiology program. The facility will include inpatient services, surgical services, diagnostic and treatment services, outpatient clinic, clinical support staff area, administrative support, and cardiac rehabilitation services space.

MILESTONES:

	Projected	Revised	Actual
Arch/Eng Approved B/T	7/7/2000		7/7/2000
Constr Mgr Approved B/T	2/2/2001		2/2/2001
Bidding Approved B/T	12/1/2000	3/1/2002	
Arch/Engr Contract	2/15/2001	1/2/2002	12/19/2001
Schematic Design Approval	6/20/2001	1/2/2002	2/4/2002
Design Development Approval	10/30/2001	4/15/2002	
Construction Document Approval	1/1/2001	10/10/2002	
Bid Opening	3/15/2001	3/8/2002	
Award of Contracts	4/18/2002	5/8/2002	
Construction Start	8/1/2002		
Report of Award to B/T	11/1/2001	2/7/2003	
Completion	3/31/2003	8/23/2004	

FUNDING INFORMATION:

Future University Bond Issues	\$ -	\$ 69,590,000.00	
HB640 Line Item Appropriation	2,610,000	2,610,000	
Development-University Hospitals	63,790,000	10,000,000	
Total	\$ 66,400,000	\$ 82,200,000	

USES:

Constr. Mgr.	\$ -	\$ 2,805,000	
Construction	37,000,000	51,000,000	
Cont. Medical	-	37,764	
Contingency	4,181,000	6,700,000	
Design	2,775,000	4,395,236	
Equipment	22,000,000	16,650,000	
Univ. Administration	444,000	612,000	
Total	\$ 66,400,000	\$ 82,200,000	

COMMENTS:

Site - Rhodes Hall Auditorium. Project is anticipated to be bid in multiple phases starting in March 2001. The milestone dates reflect the first phase start and the third phase completion. Project budget increased because of the site relocation from the Neuropsychiatric facility to a new building on the site of Rhodes Hall Auditorium which allows the building to function and operate more efficiently.

Heart Hospital

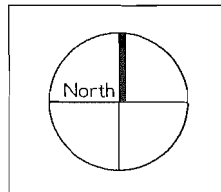
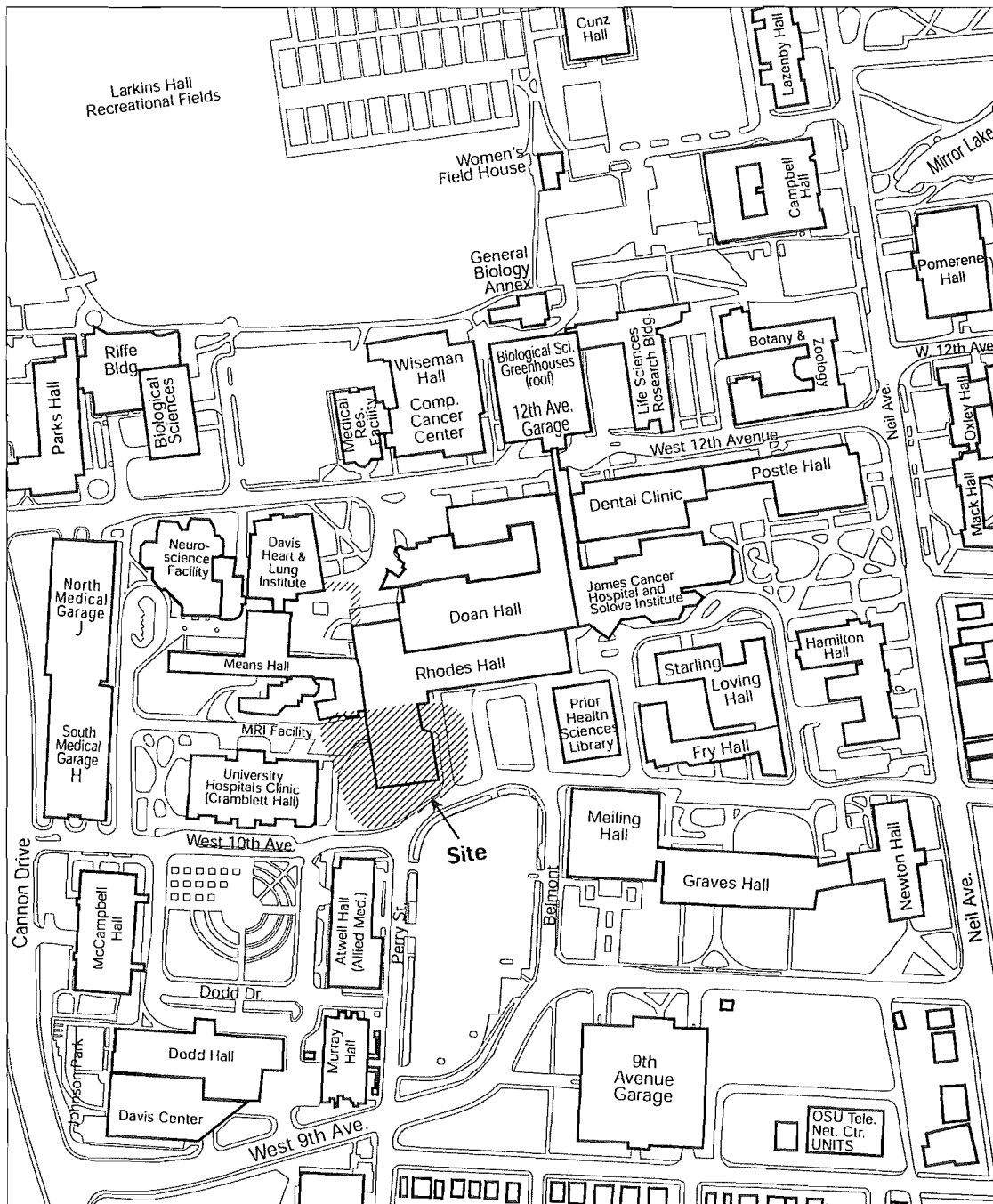

Office of Business and Finance
Office of Facilities Planning and Development

January 19, 2001

Ohio 4-H Center**315-2000-911****PROJECT CAPTAIN:**

Marjory Trishman Spangler, Facilities Planning & Development - Architecture, 292-5704

REQUESTING AGENCY:

OSU Extension

PROJECT LOCATION:

V0010-Site - See Comments.

AGE:**GR. SQ. FT.:****PROJECT DESCRIPTION:**

This project consists of the demolition of Dakan Hall and the planning, programming, design, FF&E, site planning and construction administration of the new Ohio 4-H Center. The new structure will include space for the OSU 4-H Youth Development staff, the OSU Extension programs, and those programs from the College of Food, Agricultural, and Environmental Sciences who will interact with 4-H. Outdoor program space, outdoor amenities, and parking is also included.

MILESTONES:

	Projected	Revised	Actual
Arch/Eng Approved B/T	3/1/2002		
Bidding Approved B/T	3/1/2002		
Arch/Engr Contract	7/1/2002		
Schematic Design Approval	9/30/2002		
Design Development Approval	11/25/2002		
Construction Document Approval	3/17/2003		
Bid Opening	5/6/2003		
Award of Contracts	6/16/2003		
Construction Start	6/16/2003		
Report of Award to B/T	8/1/2003		
Completion	7/1/2004		

FUNDING INFORMATION:

Ohio 4-H Foundation Board	\$	9,110,627	
Total	\$	9,110,627	

USES:

Construction	\$	6,628,751	
Contingency		1,126,888	
Design		596,588	
Equipment		662,875	
Moving		9,351	
Univ Administration		86,174	
Total	\$	9,110,627	

COMMENTS:

A study was made to determine whether renovating a current building or building a new facility would be the most feasible. Building to be constructed on the site north of the existing Dakan Hall.

Ohio 4-H Center

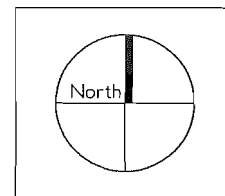
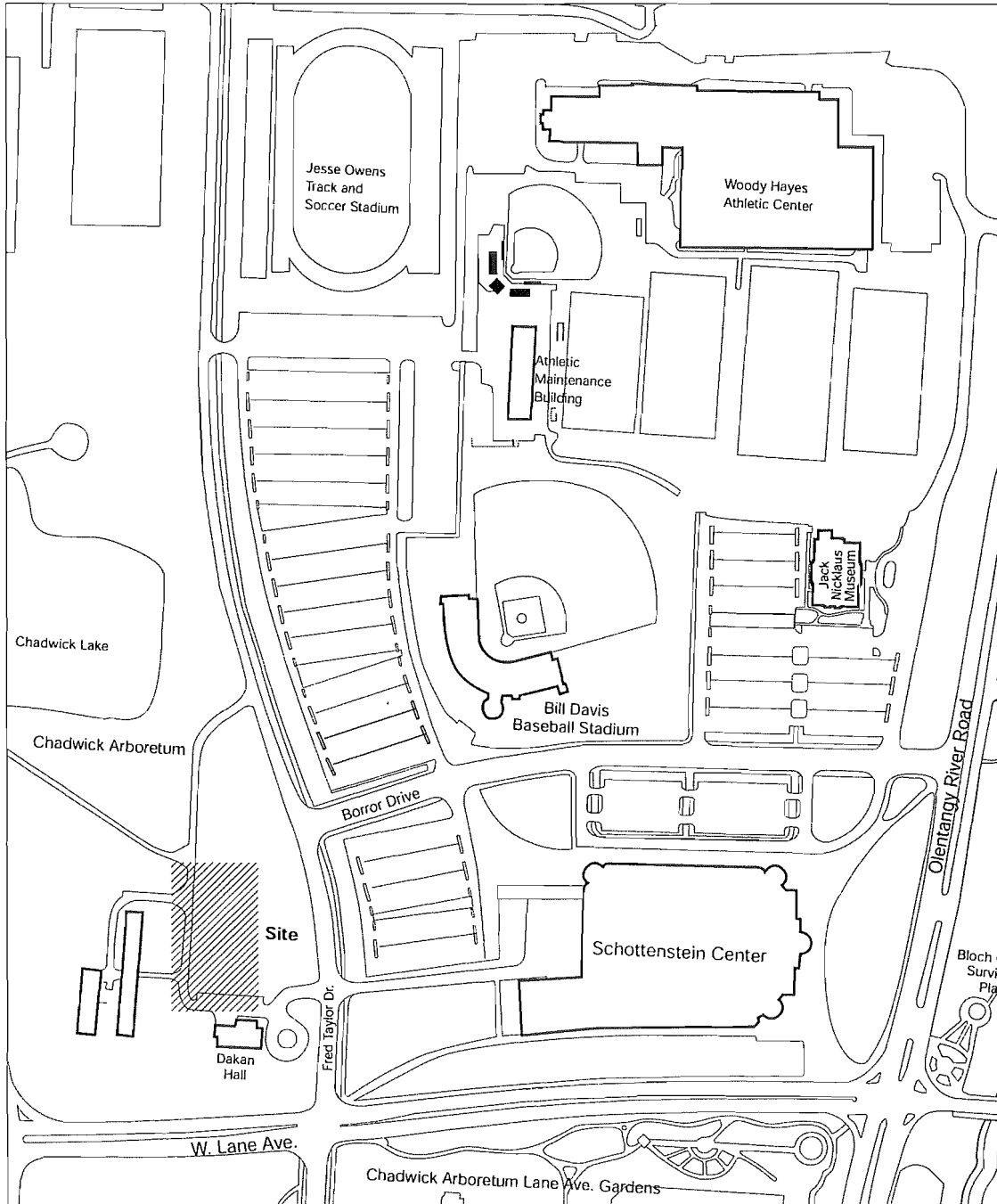

Office of Business and Finance
Office of Facilities Planning and Development

February 19, 2002

Multi-Purpose Turf Field

315-1999-188-2

PROJECT CAPTAIN:

David L. Chapman, Facilities Planning & Development - Architecture, 292-5715

REQUESTING AGENCY:

Recreation and Intramural Sports

PROJECT LOCATION:

O0000-Unidentified Mall, Plaza,Green-Col.

AGE:**GR. SQ. FT.:****PROJECT DESCRIPTION:**

Installation of a new 130 yard turf field sited on the northwest field of the Larkins four-field complex including installation of turf field lighting and filming platform. The outdoor artificial surface field will have a dual role in that it will not only be the practice field of for the marching band but it will also be scheduled for club sports through the Department of Recreational Sports. Multiple field striping overlaid on top of each other, differentiated by color, will allow the field to be used for men's and women's soccer, lacrosse and field hockey, as well as flag football. In addition, the field will also be equipped with an outdoor lighting system which will extend the use of the field significantly.

MILESTONES:

	Projected	Revised	Actual
Arch/Eng Approved B/T	3/1/2002		
Bidding Approved B/T	3/1/2002		
Construction Document Approval	2/26/2002		
Bid Opening	4/16/2002		
Award of Contracts	6/4/2002		
Construction Start	6/11/2002		
Report of Award to B/T	7/12/2002		
Completion	9/17/2002		

FUNDING INFORMATION:

Future Univ. Bond Issues	\$	264,000		
Gift Monies - Coca Cola		140,000		
Development-Business & Admin		671,000		
General Funds-Business & Admin		150,000		
Total	\$	1,225,000		

USES:

Construction	\$	1,018,010		
Contingency		114,758		
Design		79,868		
Univ. Administr		12,364		
Total	\$	1,225,000		

COMMENTS:

Multi-Purpose Turf Field

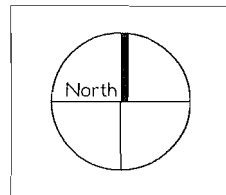
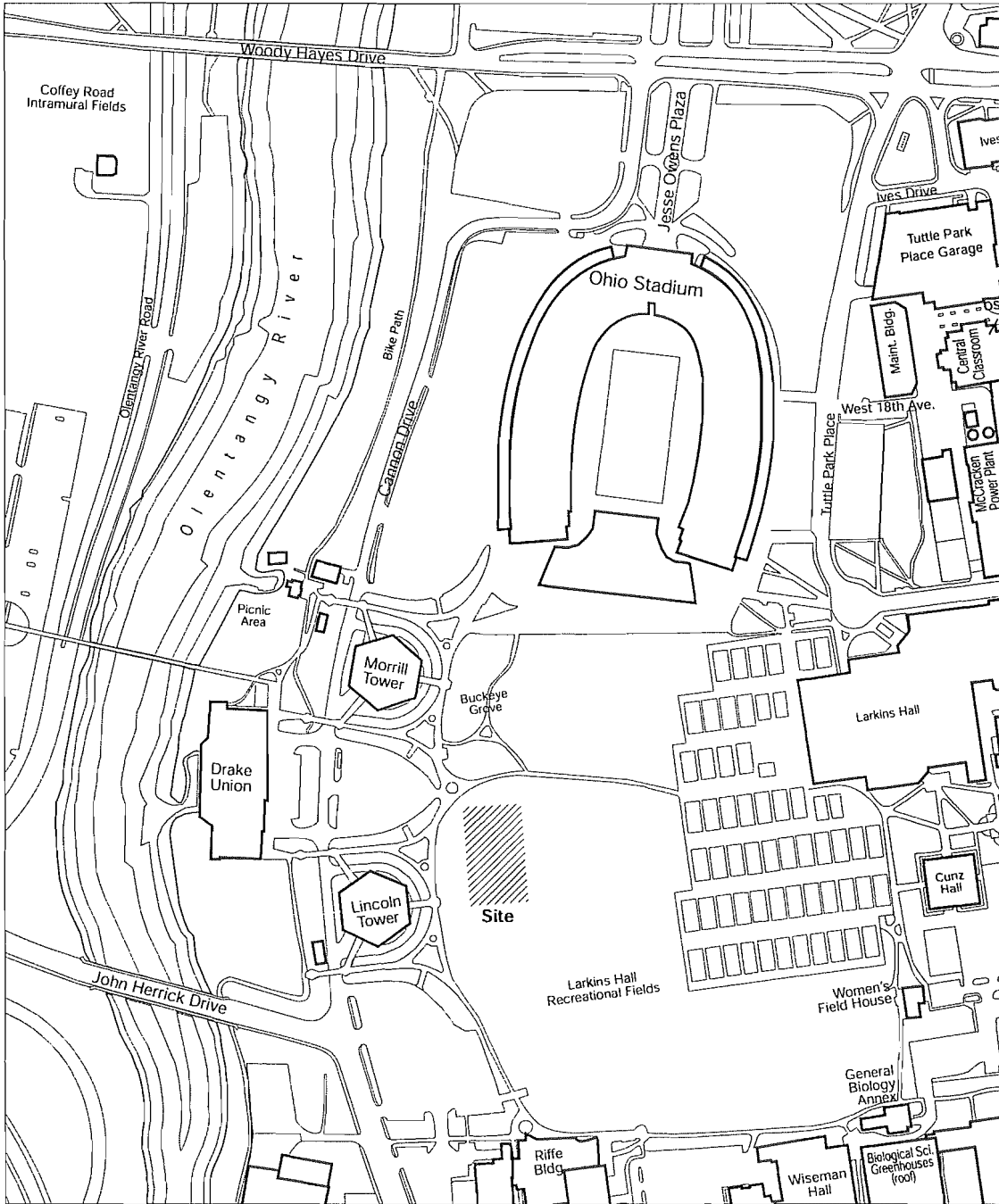

Office of Business and Finance
Office of Facilities Planning and Development

February 15, 2002

Lab Animal Facility Expansion

315-2001-932

PROJECT CAPTAIN:

Jack Bargaheiser, Facilities Planning & Development - Architecture, 247-7607

REQUESTING AGENCY:

Office of Research

PROJECT LOCATION:

0201-LABORATORY ANIMAL CENTER BUILDING 1

AGE:

1971

GR. SQ. FT.:

23,811

PROJECT DESCRIPTION:

Building #1 at the Lab Animal Facility, Godown Road was built in 1972. The building is not adequate to house animals requiring closely monitored HVAC and light requirements. The ULAR is proposing that three modular buildings be used to house animals of the LAC. Electric, water, and sewage hookups, a concrete pad, outside lighting, security hookups and a covered pathway to Building.

MILESTONES:

	Projected	Revised	Actual
Constr Mgr Approved B/T	3/1/2002		
Construction Document Approval	3/18/2002		
Construction Start	3/29/2002		
Report of Award to B/T	12/6/2002		
Completion	4/29/2002		

FUNDING INFORMATION:

General Funds-Research	\$ 500,000	\$ -	\$ -
Total	\$ 500,000	\$ -	\$ -

USES:

Construction	\$ 459,894	\$ -	\$ -
Contingency	33,476		
Univ. Administr	6,630		
Total	\$ 500,000	\$ -	\$ -

COMMENTS:

Project formerly known as 50700-R011661.

Laboratory Animal Facility Expansion

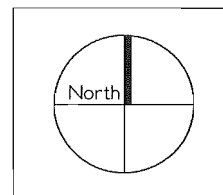
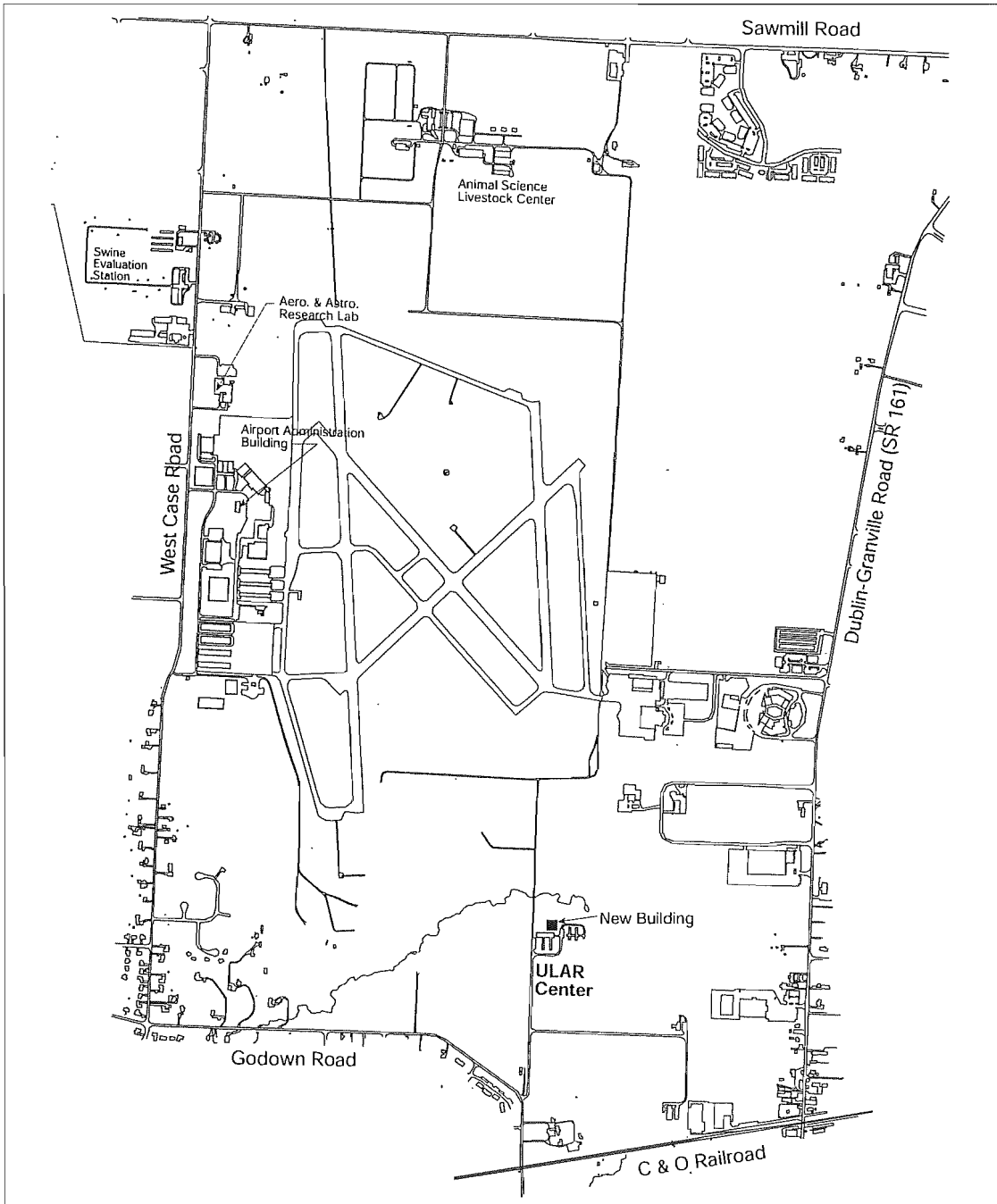

Office of Business and Finance
Office of Facilities Planning and Development

February 7, 2002

PROJECT CAPTAIN:

Marjory Trishman Spangler, Facilities Planning & Development - Architecture, 292-5704

REQUESTING AGENCY:

ATI Administration

PROJECT LOCATION:

V0008-Various Locations-ATI

AGE:

GR. SQ. FT.:

PROJECT DESCRIPTION:

Complete the exterior courtyard including landscaping. This is the final phase of the Shisler/CEED Project.

MILESTONES:	Projected	Revised	Actual
Arch/Eng Approved B/T	3/1/2002		
Bidding Approved B/T	3/2/2002		
Arch/Engr Contract	4/12/2002		
Construction Document Approval	5/17/2002		
Bid Opening	6/15/2002		
Construction Start	8/5/2002		
Report of Award to B/T	12/6/2002		
Completion	10/31/2002		

FUNDING INFORMATION:

HB640 ATI Basic-Renovations	\$ 300,000	\$ -	\$ -
Total	\$ 300,000	\$ -	\$ -

USES:

Construction	\$ 255,975	\$ -	\$ -
Contingency	24,827		
Design	15,359		
Univ. Administr	3,840		
Total	\$ 300,000	\$ -	\$ -

COMMENTS:

ATI - Shisler Center Courtyard

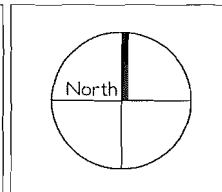
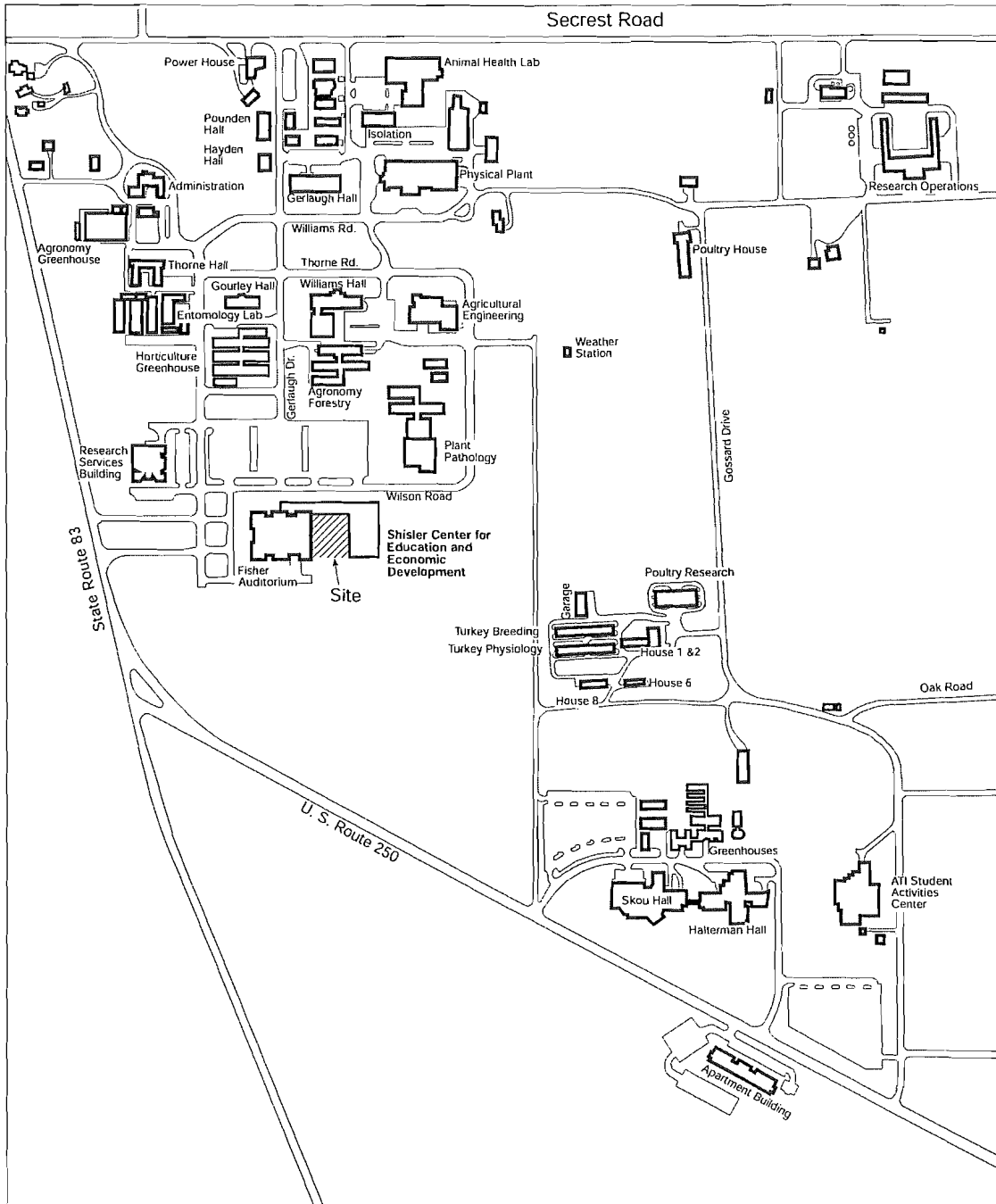

Office of Business and Finance
Office of Facilities Planning and Development

February 7, 2002

(APPENDIX XXX)

MAINTENANCE AND RENEWAL OF UNIVERSITY FACILITIES

Strategic Principles

1. Ensuring the ongoing maintenance and renewal of our facilities is an important element of the Academic Plan.
2. This applies to new buildings as well as existing buildings.
3. Funding for replacement and renewal of existing General Funds space assigned as of FY 2000 is the responsibility of the University.
4. Funding of replacement and renewal of additional General Funds space added after FY 2000 is the responsibility of the unit, regardless of funding source.
5. Funding for all non-General Funds space is the responsibility of the respective vice presidential area, regardless of when the space was built.
6. In most cases, each unit should plan to set aside 2% of the original construction cost or its equivalent annually to assure sufficient resources to comply with this policy.

(APPENDIX XXXI)

Memorandum

Subject: Revision to Board of Trustee Purchasing Policy
Date: February 21, 2002
From: Joanne Markiewicz
To: Helen DeSantis

Background

As a part of continuous review and improvement of the University's purchasing policies and practices, we have recently completed a review of the Board of Trustee policies with Legal Affairs.

Rationale

- This resolution is an effort to maintain consistency with the practices of the State of Ohio, and provides for guaranteed lowest pricing and consistent contract terms and conditions.

Resolution:

The President and/or Senior Vice President for Business and Finance is authorized on behalf of the University, on a continuing basis, to purchase without competitive bidding, equipment, materials, supplies, or services through participation in State of Ohio term schedules in which the vendor guarantees that the State will receive the lowest price as offered to the Federal government and in which the vendor agrees to accept all of the State's terms and conditions.

- This resolution provides University departments with an opportunity for product selection while still preserving the integrity, imperatives and benefits of the competitive bid process; satisfies those instances where one vendor may not be able to meet the needs of the entire University; and, maintains consistency with the practices of the State of Ohio.

Resolution:

For any contract authorized by the University's policy on purchasing, the University is authorized to make multiple awards as provided for in the University's requests for bids or proposals.

Request

Approval to submit Board of Trustee competitive bid purchasing policy recommendations.

Approval

[signed by Helen DeSantis, 21 February 2002]

Helen DeSantis, Assistant Vice President

Date

(APPENDIX XXXII)

**Fiscal Affairs Committee
The Ohio State University Board of Trustees
March 1, 2002**

TOPIC:

Second Quarter Budget Report

CONTEXT:

This is the second in a series of quarterly reports for FY 2002

HIGHLIGHTS:

- State Instructional Support for the Columbus Campus was increased by \$1.9 million in December to reflect higher than estimated enrollments and reduced by \$19.4 million as a result of the 6% executive budget cut.
- Regional Campus Instructional Support and other state line items were also reduced by 6% or \$8.9 million
- Summer, Autumn and Winter Quarter enrollments were higher than projected (Attachment A)
 - ✓ Total enrollments up 1.6%
 - ✓ Financial impact is an increase in instructional and general fee revenues above the first quarter budget adjustments of \$3.6 million or just under .5% of the General Funds Budget. This adjustment is \$1 million above what was anticipated in the budget projections used in the February 1 presentation to the Board on tuition options.
- Indirect Cost Recoveries from sponsored programs through the first six months are higher than projected.
 - ✓ Indirect Cost Recoveries up 17%.
 - ✓ Financial impact is projected to be \$8-10 million.
 - ✓ These moneys are earmarked by university policy for investment in research infrastructure and possible distribution to the colleges in FY 2003 in accordance with the principals of Budget Restructuring.
- Ohio State University Health System finances are improving compared to last year but are below budget. (Attachment B)
 - ✓ First six months minus \$5.3 million compared to:
Minus \$7.6 million last year
Plus \$1 million budget target
 - ✓ Strong January results will help offset weaker than expected December results.
- Athletics is meeting financial targets but will continue to be monitored. The Schottenstein Center is meeting revenue projections but sharply increased utility costs may adversely affect year-end results.
- Other General Funds and Earnings budgets are being realigned to more closely reflect actual income and expenditures.

RECOMMENDATIONS:

- Revise the Current funds budget as of the second quarter to reflect revenue and expenditure adjustments outlined above.
- Freeze spending of additional resources until solution to the FY 2003 budget challenge is determined.
- Method and timing to replenish the Rainy Day Fund still to be determined.

REQUESTED OF FISCAL AFFAIRS COMMITTEE:

Approval of the second quarter budget resolution.

Headcount Enrollments Summer & Autumn 2001 and Winter 2002

Category	Projected ¹	Actual ²	Difference	% Change
Undergraduate	80,719	82,100	+1,381	+1.7%
Graduate	25,738	25,883	+147	+0.6%
Professional	6,690	6,967	+277	+4.1%
Total	113,147	114,950	+1,803	+1.6%

NOTE: Includes total of Summer, Autumn and Winter Quarters

SOURCE: Resource Planning and Institutional Analysis

¹ Projected in May 2001 for FY 2002 budget.

² Reflects 14th day enrollment counts

THE OHIO STATE UNIVERSITY HEALTH SYSTEM FINANCIAL SUMMARY

YTD Ending December 31, 2001
(In Thousands)

	Actual 2002 (6 Months)	Budget 2002 (6 Months)	Actual 2001 (6 Months)
Net Patient Revenue	322,309	310,516	276,450
Other Income	21,435	21,775	19,582
Total Income	343,744	332,291	296,032
Expenses	349,060	331,249	303,656
Revenue Over Expenses	-5,316	+1,042	-7,620

SOURCE: The Ohio State University Health System
February 11, 2002

SUMMARY OF BUDGETED RESOURCES AND EXPENDITURES
FY 2002 SECOND QUARTER BUDGET REPORT
(In Thousands)

Resources

Government Support
Student Fees
Auxiliaries
Hospitals
Other

Total Resources

Expenditures

Instructional & General
Auxiliaries
Hospitals
Other

Total Expenditures

Net

One Time Adjustments

College/Office Reallocation
Use of Rainy Day Fund
Other Central Funds
Net After Adjustments

	Original Budget			2nd. Quarter Budget Revision			Difference		
	General Funds	Other Funds	Total	General Funds	Other Funds	Total	General Funds	Other Funds	Total
Government Support	404,109	329,698	733,807	391,286	323,771	715,057	(12,823)	(5,927)	(18,750) (1)
Student Fees	387,827	8,935	396,762	396,919	8,935	405,854	9,092	0	9,092 (2)
Auxiliaries		170,079	170,079		170,079	170,079	0	0	0
Hospitals		725,040	725,040		725,040	725,040	0	0	0
Other	35,547	254,388	289,935	40,127	264,388	304,515	4,580	10,000	14,580 (3)
Total Resources	827,483	1,488,140	2,315,623	828,332	1,492,213	2,320,545	849	4,073	4,922
Instructional & General	736,680	167,727	904,407	756,249	174,800	931,049	19,569	7,073	26,642 (4)
Auxiliaries	1,439	175,904	177,343	1,439	175,904	177,343	0	0	0
Hospitals		732,869	732,869		732,869	732,869	0	0	0
Other	88,796	404,109	492,905	81,496	404,109	485,605	(7,300)	0	(7,300) (5)
Total Expenditures	826,915	1,480,609	2,307,524	839,184	1,487,682	2,326,866	12,269	7,073	19,342
Net	568	7,531	8,099	(10,852)	4,531	(6,321)	(11,420)	(3,000)	(14,420)
College/Office Reallocation							8,517		8,517 (6)
Use of Rainy Day Fund							5,000		5,000
Other Central Funds							4,029		4,029
Net After Adjustments	568	7,531	8,099	(10,852)	4,531	(6,321)	6,126	(3,000)	3,126 (7)

- (1) General Funds: +\$1.9M Columbus Campus Subsidy for enrollment changes, +\$7.7M in indirect cost recoveries, -\$19.4M (6%) Columbus Campus budget cut, -\$1.2M (6%) Regional Campus budget cut, -\$1.8M (6%) line item appropriation cuts.
Other Funds: -\$5.9M (6%) in other restricted State line item appropriations.
- (2) General Funds: +\$9.1M in Columbus Campus Fee Income due primarily to an increase in undergraduate enrollments.
- (3) General Funds: +\$2.6M increase in Private Grants Indirect Cost Recoveries, +\$2.0M in Endowment Income to align with Budget vs Actual.
Other Funds: +\$10M in Earnings Departmental Sales & Services to reflect increased activity over budget.
- (4) General Funds: -\$1.2M in Regional Campus expenditures due to a reduction in Instructional Subsidy, -\$1.8M due to line item appropriation cuts, +\$10.3M for commitments against the increase in indirect cost recoveries, +\$7.3M from Other Expenditures to align with Budget vs Actual. +1.8m for additional graduate fee authorizations associated with increased graduate enrollments, +\$2M in additional unrestricted Endowment related expenditures, +\$1.2M additional Revenue Enhancement for Professional Schools due to increased enrollments.
Other Funds: +\$13M in Earnings I&G to align with increase expenditures, -\$5.9M to reflect the reduction in restricted State line item appropriations.
- (5) General Funds: -\$7.3M Adjustments to realign the budget to actual between Other and Instructional & General Expenditures.
- (6) One-Time Sources: The budget shortfall will be made up from one-time sources.
- (7) Net After Adjustments: The \$6.1M increase in the General Fund is due to the fee increases and will be held central pending possible additional state budget cuts.

Summary of Proposed University Staff Severance Program

Rationale

The university has traditionally provided working notice based on years of service as the informal mechanism for supporting staff whose positions are abolished. This proposes the adoption of a formal severance pay program with guidelines outlining appropriate working notice periods and severance pay schedule. This will ensure consistent economic support for all eligible staff and assist everyone concerned with a speedier transition process. We also believe this is an important program for an employer aspiring to achieve world-class human resource practices and desiring to communicate positive values to staff.

Eligibility

- Regular Unclassified staff at 50% FTE (full-time equivalent) or greater who are involuntarily terminated due to reduction in force. Seasonal employees are not included in the program.
- Regular Classified Civil Service staff at 50% FTE or greater who experience job abolishment, and are either involuntarily terminated or volunteer to terminate rather than exercise bumping rights. Seasonal employees are not included in the program.
- The severance pay program does not apply in any case where a staff member is being terminated for performance reasons or other appropriate cause.

Staff appointments funded by external grants and contracts are not eligible. Appointments on all other funding sources are eligible. See policy for final eligibility details.

Program Design Overview

- Eligible employees are entitled to a base of two weeks plus one and one-half weeks for each completed year of continuous service with the university. A maximum of 26 weeks has been established (see *Attachment A, page 2*).
- Severance pay, healthcare benefits, retirement benefits (subject to retirement system and IRS regulations) will continue for the time period noted on the schedule. Employees will be eligible for other benefits as outlined in the policy. Severance and benefits will cease if/when the individual receives other employment, or when the maximum benefit is achieved.
- This program entitles a benefit based upon years of service that combines periods of working notice and pay continuation. A minimum notice period of two weeks has been established for the university. Units are provided discretion to divide the total weeks of notice and severance pay in a way that best meets their needs. However, working notice may not exceed two-thirds of the total weeks of severance benefits unless agreed by the staff member.
- The amount of severance pay will be determined by an individual's base pay and FTE level. Severance pay will be paid monthly or biweekly (based upon the individual's appointment at the time of reduction) and will reflect all applicable deductions including taxes and benefits.
- Severance payment costs will be borne by the employing department.

University Staff Severance Program Schedule

The following schedule details the working notice period and severance pay that eligible individuals will receive if involuntarily terminated due to reduction in force. Eligible employees are entitled to a base of two weeks plus one and one-half weeks for each completed year of service with the university, up to a maximum of 26 weeks.

Completed Years of Service	Total Weeks of Severance Benefits	Minimum Working Notice Period	Maximum Pay*
1 or less	3.5	2	2
2	5	2	3
3	6.5	2	5
4	8	2	6
5	9.5	2	8
6	11	2	9
7	12.5	2	11
8	14	2	12
9	15.5	2	14
10	17	2	15
11	18.5	2	17
12	20	2	18
13	21.5	2	20
14	23	2	21
15	24.5	2	23
16 +	26	2	24

***Pay for half weeks has been rounded up to next whole week**

All severance pay will be determined by an individual's base pay, paid pursuant to payroll practices and will reflect deductions for applicable taxes and benefit deductions.

Summary of Proposed University Health System Severance Program

Eligibility

- Regular Unclassified staff at 50% FTE (full-time equivalent) or greater who are involuntarily terminated due to reduction in force. Seasonal employees are not included in the program.
- Regular Classified Civil Service staff at 50% FTE or greater who experience job abolishment, and are either involuntarily terminated or volunteer to terminate rather than exercise bumping rights. Seasonal employees are not included in the program.
- The severance pay program does not apply in any case where a staff member is being terminated for performance reasons or other appropriate cause.

Staff appointments funded by external grants and contracts are not eligible. Appointments on all other funding sources are eligible. See policy for final eligibility details.

Program Design Overview

- Eligible employees are entitled to one week of severance for each completed year of continuous service with the university/university health system. A maximum of 25 weeks has been established.
- Severance pay, healthcare benefits, retirement benefits (subject to retirement system and IRS regulations) will continue for the working notice/severance period. Employees will be eligible for other benefits as outlined in the policy. Severance and benefits will cease if/when the individual receives other employment, or when the maximum benefit is achieved.
- This program entitles a benefit based upon years of service that combines periods of working notice and pay continuation. A minimum notice period of 30 days has been established for the health system. Departments are provided discretion to divide the total weeks of notice and severance pay in a way that best meets their operational needs.
- The amount of severance pay will be determined by an individual's base pay and FTE level. Severance pay will be paid monthly or biweekly (based upon the individual's appointment at the time of reduction) and will reflect all applicable deductions including taxes and benefits.
- Severance payment costs will be borne by the employing cost center/department.

THE OHIO STATE UNIVERSITY
OFFICIAL PROCEEDINGS OF THE
ONE THOUSAND THREE HUNDRED AND EIGHTY-FIRST MEETING
OF THE BOARD OF TRUSTEES

Columbus, Ohio, April 5, 2002

The Board of Trustees met at its regular monthly meeting on Friday, April 5, 2002, at The Ohio State University Longaberger Alumni House, Columbus, Ohio, pursuant to adjournment.

**

**

**

Minutes of the last meeting were approved.

**

**

**

April 5, 2002 meeting, Board of Trustees

The Chairman, Mr. Brennan, called the meeting of the Board of Trustees to order on April 5, 2002, at 9:45 a.m. He requested the Secretary to call the roll.

Present: David L. Brennan, Chairman, James F. Patterson, Zuheir Sofia, Tami Longaberger, Daniel M. Slane, Robert M. Duncan, Karen L. Hendricks, Dimon R. McFerson, Jo Ann Davidson, Kevin R. Filiatraut, and Joseph A. Shultz.

--0--

CHAIRMAN'S REPORT

Mr. Brennan:

Good morning, ladies and gentlemen. Since our last Board meeting, we have been presented with two very unfortunate events. The first, as you all know, was the untimely and tragic death of Michael Moritz.

I had lunch with him the day of his unfortunate accident, and we discussed at length the impact of his gift to Ohio State. With great feeling, he expressed the fact that each day, since he had made that gift, he enjoyed it more than the previous day. That as satisfying as the gift was to complete last June, the continuing joy and pleasure to him was beyond anything he had expected to experience. He had discovered one of the greatest gifts of life -- the joy of giving.

Mike will be remembered for a number of reasons: the size of his gift, his name permanently associated with the law school, but most importantly, he will be remembered for making that gift for all the right reasons -- to help others, to help The Ohio State University, and to provide a lasting payback for the many good things that came his way during his life. I think a moment of silence in remembrance of Mike is appropriate. May he rest in peace.

The other unfortunate recent event is the impending departure of President Kirwan. As we all know, President Kirwan has accepted an offer to return to his home State of Maryland, where he will become the Chancellor of the University System -- and much closer to his children and grandchildren. Let me add, Brit, that when I saw that picture in the newspaper of your two grandsons, I understood the attraction. As you know, grandchildren are the reward for not killing your children. Most parents enjoy that observation, just as you are all enjoying it.

Members of the Board of Trustees have the opportunity to observe a president at very close range -- to test his judgment, evaluate his energy and determination, see how he relates to a wide variety of people, and gauge his effectiveness. This president ranks very high -- practically off the scale -- on these and other qualities. No one, in my view, could have accomplished more during recent years than Brit Kirwan has accomplished. He will leave Columbus with a great legacy and many lasting achievements. Foremost among them, of course, is the Academic Plan that this Board approved enthusiastically in December 2000, just 16 months ago.

From the President's progress reports each month, we know that this Plan is already beginning to transform Ohio State into one of the really great public universities. The Plan's strategies, which include building a world-class faculty and enhancing and better serving the student body, are sound. The initiatives and timetables are challenging yet doable, and the Plan is broadly supported by the various campus and community constituencies. For these and other reasons, the Board continues to strongly support the Academic Plan.

I would like to add that in 1995 when this Board adopted the 20/10 Plan -- which was the foundation for all that has followed -- and from every day since then this

CHAIRMAN'S REPORT (contd)

Mr. Brennan: (contd)

Board has unanimously, forcefully been committed to exceeding every prior accomplishment and taking this University to the highest level of excellence possible.

As we fulfill our responsibility to select the next president, therefore, we will not only seek the best possible candidate, we will also seek a candidate who subscribes to the goals and broad approach that are the basis of the Academic Plan. In short, we seek a leader who is committed and able to take us where we want to go, who will move The Ohio State University to the next level of excellence. Of course, any president worth his or her salt will and should stamp a unique, indelible imprint on our future. Such a person will bring his own talents, own style and, certainly, own ideas. But this need not be inconsistent with maintaining our current direction. We are also eager to complete this process as soon as possible without sacrificing in any way quality, thoroughness, or due diligence.

We begin with a resolution that is before the Board today. This resolution appoints a Presidential Search Committee that is charged with recommending to this Board one or more candidates to be the next president of The Ohio State University. The Committee will develop a profile of characteristics, skills, and qualities desired for the next president; develop a list of candidates qualified to hold this important office; and screen those candidates. The Committee will also verify the candidates' qualifications and interests in the position and recommend the best possible candidates to the Board.

The Committee is broadly representative of the campus community. The resolution has been amended to add a professional student to the committee and will now consist of 18 members, and will be chaired by James F. Patterson, vice chair of the Board.

**AMENDED ESTABLISHMENT AND APPOINTMENT OF
PRESIDENTIAL SEARCH COMMITTEE**

Resolution No. 2002-101

Synopsis: Establishment and appointment of Presidential Search Committee is proposed.

WHEREAS Dr. William E. Kirwan has announced his decision to relinquish the presidency of The Ohio State University in order to assume the chancellorship of the University System of Maryland; and

WHEREAS it is the responsibility of the Board of Trustees, pursuant to section 3335.09 of the Ohio Revised Code, to select the President of the University; and

WHEREAS the Board of Trustees has determined that it is appropriate to establish and appoint a Search Committee with broad representation of University constituencies and charge it with responsibility for recommending to the Board one or more candidates to be the next President of the University; and

WHEREAS in order to proceed expeditiously with the commencement of the search it is appropriate to constitute and give an initial charge to the Search Committee:

NOW THEREFORE

**AMENDED ESTABLISHMENT AND APPOINTMENT OF
PRESIDENTIAL SEARCH COMMITTEE (contd)**

BE IT RESOLVED, That the Search Committee for President of The Ohio State University will have the following membership:

Trustees

James F. Patterson, Chair
Robert M. Duncan
Karen L. Hendricks
Dimon R. McFerson

Members of the Faculty

Bruce E. Bursten, Chair and Professor, Department of Chemistry
Susan Fisher, Professor, Department of Entomology/Secretary of the University Senate
David O. Frantz, Professor, Department of English
Jacqueline J. Royster, Professor, Departments of English and African-American and
African Studies/Associate Dean, College of Humanities
Marilynn Brewer, Professor, Department of Psychology

Deans

Fred Sanfilippo, Senior Vice President for Health Sciences/Dean of the College of
Medicine and Public Health
James C. Williams, Dean, College of Engineering

Students

Edward Pauline, President, Undergraduate Student Government
Marsha R. Robinson, Graduate Student, Ph.D. candidate in History
Soraya Rofagha, Professional Student, College of Medicine and Public Health

Administrators

Jerry A. May, Vice President for Development/President of the University Foundation
Mac A. Stewart, Vice Provost for Minority Affairs

Alumni Association representative

Dan L. Heinlen, President and CEO, Alumni Association

Non-Teaching Staff

Willa Young, Chair, Staff Advisory Council

BE IT FURTHER RESOLVED, That James F. Patterson shall serve as Chair of the Search Committee and that the following people will serve the Board and Committee as follows: William J. Napier, liaison; Virginia M. Trethewey, general counsel; and Mary A. Basinger, administrative coordinator; and

BE IT FURTHER RESOLVED, That each member of the Search Committee shall commit herself or himself to representing the best interests of the University in planning and directing all aspects of a comprehensive and expeditious search for a new President including, but not limited to, developing a profile of characteristics, skills and qualities desired in the next president; developing a list of candidates and verifying their qualifications, availability and interest in the position; and making a recommendation of one or more candidates to the Board; and

**AMENDED ESTABLISHMENT AND APPOINTMENT OF
PRESIDENTIAL SEARCH COMMITTEE (contd)**

BE IT FURTHER RESOLVED, That the Chair of the Search Committee shall provide periodic updates to the Board of Trustees at its regularly scheduled meetings until the search is concluded; and

BE IT FURTHER RESOLVED, That the Search Committee shall serve until discharged by the Board of Trustees or upon the appointment of a new President; and

BE IT FURTHER RESOLVED, That any actions taken by the Search Committee or the Chair in furtherance of this Resolution prior to its effective date are hereby ratified and approved.

Upon motion of Judge Duncan, seconded by Ms. Hendricks, the Board of Trustees adopted the foregoing resolution by unanimous roll call vote, cast by Messrs. Brennan, Patterson, Sofia, Slane, McFerson, and Judge Duncan, Meses. Longaberger, Hendricks, and Davidson.

CHAIRMAN'S REPORT (contd)

Mr. Brennan:

A second resolution before the Board today provides for the engagement of a search firm to assist the Committee in its important work.

CONTRACT TO RETAIN PRESIDENTIAL SEARCH CONSULTANT

Resolution No. 2002-102

Synopsis: Contract to retain a national search consultant to assist the Presidential Search Committee is proposed.

WHEREAS the Board of Trustees has initiated a search process to identify qualified candidates for the Presidency of the University; and

WHEREAS a Search Committee is being appointed and charged with planning and directing all aspects of a comprehensive and expeditious search; and

WHEREAS it is established practice to select a professional search firm to serve as a consultant to the Search Committee and the Board of Trustees, providing advice, expertise and administrative support in the identification, screening and recruiting of the most highly qualified candidates for the Presidency; and

WHEREAS in order to identify professional search firms capable of providing the quality of services deemed desirable by the Search Committee and the Board of Trustees, a Request for Proposals has been issued by the Purchasing Department of the University and sent to search consulting firms located in Ohio and throughout the country; and

NOW THEREFORE

BE IT RESOLVED, That the University will retain a professional consultant to the Search Committee and the University to assist in the search for the next President of the University; and

BE IT FURTHER RESOLVED, That based upon the recommendation of the Search Committee, the Senior Vice President for Business and Finance be and hereby is authorized to enter into a contract of engagement with the selected national search consultant, on terms favorable to the University and consistent with the response to the Request for Proposals; and

CONTRACT TO RETAIN PRESIDENTIAL SEARCH CONSULTANT (contd)

BE IT FURTHER RESOLVED, That any actions taken by the Search Committee or the chair in furtherance of this Resolution prior to its effective date are hereby ratified and approved.

Upon motion of Ms. Hendricks, seconded by Mr. McFerson, the Board of Trustees adopted the foregoing resolution by unanimous roll call vote, cast by Messrs. Brennan, Patterson, Sofia, Slane, McFerson, and Judge Duncan, Mses. Longaberger, Hendricks, and Davidson.

CHAIRMAN'S REPORT (contd)

Mr. Brennan: (contd)

Finally, we have determined that the President's Planning Cabinet will assume responsibility for any transition initiatives. It would be foolish to speculate as to how long the search process will take. I speak for the entire Board when I say that the process will be conducted as quickly as possible, consistent with the outcome we seek. Before June 30, the Board will make a decision on interim leadership for the University after July 1.

However, I want to emphasize that in the period between President Kirwan's departure on June 30 and the arrival of a new president, this Board will do all within its power to encourage a continuation of the momentum that has been built over recent years. Let me be very clear: we do not see the upcoming months as a time to run-in-place or postpone important decisions until a new president arrives. To the contrary, we urge the administration, faculty, and staff to continue to recruit outstanding faculty and students, to proceed with the Diversity Action Plan, to make the student experience as meaningful as possible, to help build Ohio's economy, and in general to make as much progress as we possibly can.

We recognize that for now, we continue to face difficult economic issues. However, Ohio is not the only state in this predicament, and every indication is that the economy will improve as the year progresses. Looking ahead, we on the Board have every confidence that our goals are realistic and that the future of our University is very bright. We are likewise confident in our ability to attract another outstanding leader. The Ohio State University is a very special place. We have every reason to expect the very best.

--0--

PRESIDENT'S REPORT

President William E. Kirwan:

Before I give my report I want to thank you, Chairman Brennan, for your very generous comments this morning. I am genuinely touched by them. I think all of the members of the Board know what an honor and privilege I feel it is to serve as president of this great University, and the support that you have given me during my tenure, and especially over the past few weeks, is something I will always remember and treasure.

I also want to thank the faculty, staff, and students, and others who called or wrote me over recent weeks about my decision to return to Maryland. This includes especially the response at Winter Commencement. These demonstrations of support not only made an already difficult decision nearly impossible to make, they also reinforced for Patty and me just how difficult it will be for us to leave. Our appreciation for this community, the friendships we have

PRESIDENT'S REPORT (contd)

President Kirwan: (contd)

made since arriving here, and the genuine affection we have for this University will live with us forever.

As noted in my letter to the campus community, over the next three months I will devote my full attention and energy to completing a series of important projects and to making the smoothest possible transition to new leadership. As I've said to several people, I will try to be the best "lame duck" president ever. It is the least I can do to demonstrate my deep and abiding affection and appreciation for The Ohio State University community.

My agenda over the next 90 days includes the full implementation of the four Academic Plan initiatives identified last June. These four initiatives were chosen not only because of their intrinsic merit, but also because they were financially doable in the current fiscal environment. Thus, while the need for additional state funding continues to be a concern, by implementing these initiatives we are demonstrating meaningful progress toward the goals of the Academic Plan.

As you know, our number one priority and chief focus is the compensation of our faculty and staff. Competitive compensation is an essential building block of our Academic Plan. We simply cannot be an excellent university without faculty and staff compensation that is competitive with our benchmark peer institutions. We are becoming steadily less competitive in faculty and staff salaries. Today, you will be updated on where we stand relative to our benchmark universities.

The challenge that we face is real and substantial. Providing our faculty and staff with competitive compensation will take several years, but we must begin to make progress this year. Our medium-term compensation goal is to be at the median level of our benchmark universities for faculty and of appropriate benchmarks for staff. To do so, our strategy is to provide salaries over the next three or four years that on average meet both current market increases and include up to an additional one percent per year in catch-up funds. We are close to finalizing the compensation budget for the year beginning July 1, which will be the initial step in reaching this goal.

The second initiative is to strengthen our undergraduate program, primarily using tuition revenue. These improvements include better enhanced advising services, classroom technology, fewer closed out sections, smaller class sizes, additional Scholars programs, and better classroom instructional support for faculty and Teaching Associates.

The third initiative is the creation of an Institute for the Study of Race and Ethnicity in the Americas, using funds earmarked last year. Thanks to the excellent work of Ruth Peterson and her search committee, we recently recruited an exceptional individual to help us fulfill the Institute's potential. Later in the meeting, you will be asked to approve the appointment of John Powell as director of the Institute, and as the holder of The Gregory H. Williams Chair in Civil Rights and Civil Liberties in the Moritz College of Law.

Professor Powell comes to us from the University of Minnesota, where he founded and is executive director of the Institute on Race and Poverty. Currently, he holds the Earl R. Larson Chair in Civil Rights and Civil Liberties at Minnesota's law school. John Powell is a nationally recognized authority in the areas of civil rights, civil liberties, and issues relating to race, poverty, and the law. With his appointment, the Institute is in very capable hands.

PRESIDENT'S REPORT (contd)

President Kirwan: (contd)

The final academic initiative for this year is to develop excellence in biomedical research utilizing, in part, the Tobacco Settlement funds. Critical to the success of this initiative is the creation of state-of-the-art facilities and, to that end, we are moving forward with our plans for a biomedical research tower. We will soon share with the Board of Trustees a completed business plan that fully supports the construction of this important facility.

Although not on our list of short-term Academic Plan initiatives, I also expect important near-term progress on the University's Gateway Center project. Campus Partners has completed land acquisition and has successfully relocated all remaining businesses from the Gateway area. It also has selected a demolition contractor and filed for a demolition permit. We hope that the Trustees can join us in hard hats in a few weeks, as demolition will begin sometime this month. Utility work will start shortly after that with construction plans for early next year.

Let me turn to an important item on today's Board agenda. Last month the Board approved our tuition proposal for the Columbus campus, which will go into effect this summer. Today, we are seeking your approval for the remaining parts of the University's tuition package, namely tuition at our Regional Campuses and ATI, and for non-resident students. The recommendations before you are consistent with our previous discussions and consistent with the Governor's policy. In the case of the Regional Campuses and ATI, we propose increases that average just under 10 percent. We also propose that the surcharge for non-resident students increase by 7.5 percent, rather than the traditional five percent.

As I've said repeatedly, all of our financial decisions assume no further reduction in state support. We are all aware of the state's continuing revenue problems. We can only hope that this time those problems are not solved at the expense of higher education. I want to thank the Governor for the commitment he made yesterday to spare higher education from any further budget cuts at this time.

Despite Spring Break, the past month has been very busy and I want to call your attention to several important items. As the chairman noted, March began tragically with the death of Mike Moritz, a wonderful man and a huge benefactor of our University. We miss him very much, but are pleased that his legacy will live on at the Moritz College of Law. In fact, new data from *U.S. News and World Report* validate the college's continuing rise in reputation. It now ranks 37th among the nation's law schools, up from 40th last year; and 15th among public law schools, up from 17th one year ago. And the Moritz College of Law's dispute resolution program has moved even higher up the scale, from fourth place to third among all of America's law schools.

I am also happy to report that Winter Commencement was a terrific event at which our Board Chair gave a very moving and inspirational address to more than 1,500 joyous graduates. And subject to your approval today, the College of the Arts has a new dean in Karen Bell, whom we are also recommending be promoted to full professor. Karen is a well-known choreographer and performer, who previously served as chair of our top-ranked dance program and who has done an outstanding job as interim dean.

Taking advantage of our unique combination of disciplines, we have formed a multidisciplinary research program designed to assist federal and state officials in better understanding the causes of international terrorism and finding appropriate solutions. This initiative also includes collaboration with the Battelle Memorial

PRESIDENT'S REPORT (contd)

President Kirwan: (contd)

Institute. We will provide our research capabilities while Battelle will use its expertise to transform basic research into useful products and ideas.

Subject to your approval, this Program for International and Homeland Security will be headed by retired Air Force Major General Todd Stewart. General Stewart was formerly director of plans and programs for the Air Force Materiel Command Headquarters at Wright-Patterson Air Force Base. General Stewart is with us today, and I'd like him to please stand so we can welcome him to our community.

Professors Lonnie Thompson and Ellen Mosley-Thompson, our internationally acclaimed experts on global warming, have been chosen to receive yet another high honor -- the Common Wealth Award of Distinguished Service for science and invention. They will join Julie Andrews, Carlos Fuentes, and George Mitchell, who are also receiving Common Wealth Awards this year. In years past, winners of this award have included Archbishop Desmond Tutu, Henry Kissinger, Jacques Cousteau, and Mikhail Baryshnikov. Not bad company!

Congratulations are due to Coach Jim O'Brien's men's basketball team. Picked to finish seventh in the Big Ten, the team earned a share of the Big Ten title, won the Big Ten tournament outright, and went to the NCAA tournament for their fourth consecutive year -- the first team in Ohio State history to do so. It is also worth noting that the men's gymnastics team won its second consecutive Big Ten championship, beating out second-place Michigan.

At the last Board meeting, I noted that two students had advanced to the final round of the prestigious Truman Scholarship competition. I am pleased to inform you that one of them, Eburn Taiwo, was successful. She is an honors student in political science and African-American studies -- one of 64 students nationwide to be so selected. We have also just learned of two Goldwater Scholarship winners. They are: Cullen Buie, a junior in mechanical engineering; and Michael Tychonievich. Nationally, only 309 scholarships were awarded from a field of almost 1,200 mathematics, science, and engineering students.

Finally, Ohio State is among 12 universities considered the best in the nation in contributing to state and local economic development. The designation came in a study conducted by the Southern Growth Policy Board's Southern Technology Council. The study validates the hard work that so many members of the University community have put in over recent years in relation to the knowledge economy and is an encouraging sign for Ohio's future.

Mr. Chairman and members of the Board, this completes my report.

--0--

PRESENTATION OF DUAL MAJORS/DEGREES

President William E. Kirwan:

You may recall that a few months ago Dimon McFerson expressed interest in dual majors and dual degrees. The ability to take double and even triple programs is among the strengths of Ohio State, given our wide range of offerings and our commitment to help students to take full advantage of the breadth of educational opportunities at Ohio State. In fact, about eight percent of last year's undergraduates finished with either two majors or two degrees, some of them with extremely interesting combinations.

PRESENTATION OF DUAL MAJORS/DEGREES (contd)

President Kirwan: (contd)

Martha Garland is going to give you more information on this topic, then introduce three students who will tell us how and why they are pursuing double majors. Martha --

Dr. Martha M. Garland:

Thank you, Mr. President. As the President said, we at Ohio State have always been very proud of the wide range of offerings that the University provides. We often say that a student can study really anything at Ohio State. Further, we're committed and have a strong advising staff that works very hard to be certain that students are enabled to pursue any program that they are interested in, and to put things together so that they can follow the path that they are looking toward. For a number of our students, this means that they actually pursue a serious, concentrated interest – a major, in more than one field. In fact as the President said, at the four commencements from last year, 540 undergraduate students graduated with either a double major or a dual degree.

Obviously it is easier to major in two fields that are closely allied with each other, and the most common pairing is sociology and criminology. It is harder to combine two fields if one or both of them are highly quantitative and thus involve a lot of structure and sequencing in the curriculum. Even so, this last year we had a student who received degrees in Chinese and molecular genetics, and another student who received degrees in German and transportation and logistics. We even had several triple majors last year: one student majored in physics, German, and philosophy; and another student majored in music, French, and speech and hearing therapy.

At the graduate and professional level, we also work hard to make it possible for students to pursue paired interests if that's appropriate for them. In the Medical School, we always have some students who are pursuing both the M.D. and the Ph.D. degrees in one of the basic sciences, and the Moritz College of Law is especially helpful in enabling its students to pursue work from other fields.

Today I'd like you to hear from three students who are taking advantage of this opportunity at Ohio State: Allie Brown, a junior from Baltimore, Ohio, is majoring in mathematics and philosophy; Craig Evers, from St. Henry, Ohio, is a fourth-year student studying economics and English; and Crystal Coleman, from Hartford, Connecticut, is a student in the Moritz College of Law, and is also working on a master's degree in African-American and African Studies. I've asked each of them to tell you a little bit about why they're doing this, how it's working for them, and what they think it will mean to them. We will start with Allie.

Ms. Alice A. Brown:

I'm pursuing a dual degree in both mathematics and philosophy. I actually started in the physics department and after four and a half quarters, decided it wasn't quite for me. I really loved my math classes and, fortunately, those classes were in the proper sequence that I was able to pursue at least a minor in mathematics. I then started looking for another major to take on top of it.

I talked to a lot of people in the Philosophy Department and realized that I was interested in a lot of their logic classes and the philosophy of science. So I decided I wanted to create a personalized study program in both philosophy and math, and call it a "logical studies" major. I actually balanced the options of what it really looked like as a degree, and the fact that I could actually finish in four

PRESENTATION OF DUAL MAJORS/DEGREES (contd)

Ms. Brown: (contd)

years with two degrees completed. So, I decided to do both mathematics and philosophy full-time.

I was really fortunate my freshman year – I was a little ambitious and took about 21-hours every quarter -- that all of those credit hours counted. My GEC's are pretty much done, which will make it a lot easier for me to graduate in four years. I know for most students to do something like this would require fewer GEC's in order to take advantage of the wide diversity of majors available. Even on top of that, I'm still taking electives for fun, like a law and economics class this quarter, just because I want to learn more. I like the opportunity to think both from a humanities perspective and from a purely numerical perspective. I think that I would feel really limited if I was doing one or the other, and I really appreciate the opportunity at Ohio State to do both.

Dr. Garland:

Thank you, Allie. Craig, if you would like to say a little bit about your work.

Mr. Craig R. Evers:

I'm Craig Evers and I'm pursuing a double major in economics and English. When I was in high school and started college, I was completely undecided as to what I wanted to do. I really enjoyed almost everything I did academically in high school. One of the reasons I came to Ohio State was at some point in time someone said, "At Ohio State, we have every major, except for library science and mortuary science." I have no desire to work with dead people ... it's a joke!

I used my first two years as exploration time and took a lot of the GEC requirements. At the end of the two years, I was looking at English, psychology, philosophy, economics, and music. Through some manner of decision-making, at the beginning of my junior year, I decided that economics was the way to go and I declared my economics major. After I declared the economics major, I started looking at the requirements and saw I would be done in four years and it stunned me. I realized that I wouldn't have an English degree when I was done, which upset me. I then realized that I also needed to major in English as well. Economics is numbers and English is letters, so that balances those two desires. I'm thinking that after graduation the direction is law school, although it's still completely up in the air. I will be taking the L-SAT in June, so we'll see how well that goes.

Dr. Garland:

Crystal, do you want to tell us about law school and your master's program?

Ms. Crystal Y. Coleman:

Good morning. My name is Crystal Coleman and am currently a third-year law student. Prior to going to law school my desire was, and currently is, to finish my law education and practice law as it effects cultures – people culture, mainly African Americans, but not exclusively.

After my first year of law school I knew that I would be adequately prepared to practice law, but also realized that I would be inadequately prepared to practice law in the areas that I wanted to practice in. So, I pursued a dual degree in

PRESENTATION OF DUAL MAJORS/DEGREES (contd)

Ms. Coleman: (contd)

African-American and African Studies. I felt that that particular degree would give me the full, well-rounded education to pursue the areas that I wanted to be successful in.

After getting into African-American and African Studies the first year, I knew that that's where I wanted to be. I had great professors and was under the tutelage of Drs. William E. Nelson and James Upton, both scholars in political science as well. I got my undergraduate degree in political science so it seemed as though everything was just coming to a well-rounded circle. So it was great for me.

The law school has been incredibly great in this process. The two majors are not something that most people do in law school, but it worked out for me. The deans there have helped me to make sure that I'll be finished in two years. I started this journey in my second year of law school, and I'm fortunate enough to be able to finish my law degree this semester and my master's degree in African-American and African Studies this quarter. I'm proud to say that I did very well. I'm going to be graduating from law school successfully and am graduating from African-American and African Studies with a 4.0 GPA, which I'm very proud of. Thank you.

Dr. Garland:

Thanks to all of you. Do any members of the Board have questions for the students?

Mr. Kevin R. Filiatraut:

Being a former double major myself, I know how difficult it can be at times. I'd like to hear how each of you stays a student, as well as has fun and still gets to do extracurricular activities that enhance the learning experience you get in the classroom. Especially you, Crystal, because I'm a law student and I know I don't have any time.

Ms. Coleman:

I guess I'm very fortunate. As you know, I've been very active at the law school and last year I was awarded the Outstanding Community Service and Leadership Award. It just balances everything for me. I'm married and have a four-year-old daughter and keeping busy keeps me on the path – I guess I'm just different. I do well when I'm busy. If I'm doing only one thing, at once it seems as though everything crashes because I have too much time to think about things. I have been able to be active in the law school and give my contribution, as well as do well academically. I'm just fortunate.

Ms. Brown:

I'm a pretty active student leader on campus. I'm on Dr. Garland's advisory committee, as well as about four other USG committees, cabinet, Honors Ambassadors, and some other things. I used to be on the Crew team for a while. I think it's like Crystal said, a great balance of time. I can't imagine doing anything else. I still have friends and fun places to go on weekends. It's just that being really busy makes me happy and that's what I like to do.

Dr. Garland:

How about you, Craig?

PRESENTATION OF DUAL MAJORS/DEGREES (contd)

Mr. Evers:

I suppose likewise. I'm involved in Mortar Board, which is a senior class honorary, and Honors Ambassadors, among other things. You just do it. I did it in high school – I was involved and did academics, and I really wanted that in college as well. So you get involved. You stay up late and do the homework, and then go to bed at 2:00 a.m. and wake up at 7:00 a.m. You deal with it.

Dr. Garland:

One of the things Craig is doing for the University is that he was one of the student chairs of the competition that we hold every year to recruit the highest ability honors students – the Maximus Competition. Craig was one of the organizers of all of that and master of ceremonies for it on a regular basis.

These are all very active, engaged students, but good students and people who are working hard at their academic programs.

Mr. McFerson:

I congratulate you, as well as I know my colleagues will, for what you've accomplished. You're absolutely outstanding ambassadors for Ohio State and you love school, you love to learn. When you enter the real world, I hope it's not disappointing to you. I hope that you will use that extra energy and time to continue to serve, because there are some great needs out there in society that need your skill sets, as well.

Ms. Hendricks:

I was at the Maximus Competition with my son. Craig, I didn't know whether you might want to do that dance for us?

Dr. Garland:

No, he doesn't want to do that. Thank you, though.

Mr. Brennan:

Any other questions or suggestions? I think that you caught the sense of how we all feel about what you're doing. You're exceptional young people and we're very proud you're associated with Ohio State. You'll wear that badge as a badge of honor the rest of your lives. Thank you.

--0--

**FISCAL AFFAIRS COMMITTEE MEETING
(COMMITTEE OF THE WHOLE)**

Mr. Brennan:

I would like to now call on Jim Patterson to chair the Fiscal Affairs Committee meeting. Jim --

Mr. Patterson:

Thank you, Mr. Chairman. I'd like to call to order the meeting of the Fiscal Affairs Committee, as a Committee of the Whole. I would like to call upon Bill Shkurti to begin.

**BRIEFING ON LONG-TERM LEASES/SUBLEASES
WITH YMCA FACILITIES**

Mr. William J. Shkurti:

Thank you, Mr. Chairman. The first item is the briefing report on the leases with the YMCA for the Medical Center. Like previous briefing reports, these are for long-term leases of space off-campus. We are not purchasing real property, so technically, no official action is needed by the Board, but because these are long-term leases, we wanted to make the Board aware of them.

You may wonder what is the programmatic relationship between the Medical Center and the YMCA. In fact, there is quite an intrinsic value that can come from both rehabilitation and prevention in terms of health care services. Eric Kunz, from the Medical Center, is here to provide some additional detail on the relationship between the Medical Center's programmatic need and these leases.

I should also point out that Eric is listed in the Personnel Actions' resolution showing his promotion to associate vice president for Health Sciences, which means he has responsibility for all the space in the Health Center. All my colleagues have given him the same recognition saying, "Eric, you have our condolences on your promotion," because he is responsible for quite a complex series of space relationships. But, Eric is here and he will be glad to elaborate on this if there are any additional questions from the Board regarding this particular series of leases.

(See Appendix XXXV for background information and maps on file in the Board Office.)

**EMPLOYMENT OF ARCHITECTS/ENGINEERS,
REQUEST FOR CONSTRUCTION BIDS, AND
REPORT OF AWARD OF CONTRACTS**

Mr. Shkurti:

The next item is the authorization for capital projects. We are requesting authorization to move forward on four projects: James Ambulatory Services, Morris and Seibert Fire Alarm Upgrade, Rhodes Hall Entrance, and the Stone Lab Dock Renovation and these are fairly routine projects.

Secondly, we're reporting on the Award of Contracts on four others. This includes the Graduate and Professional Student Housing project, which is important new on-campus housing -- the first such project since the late 1960s. In addition, there are also major improvements to University Hospitals East for inpatient and outpatient services, and the resolution is presented for your approval. If there are any questions, I'll be glad to respond.

Mr. Patterson:

Are there any questions on this resolution? Dimon --

Mr. McFerson:

I would like to point out that the projected cost and the revised costs are in a couple of cases here rather sharply different. Maybe you can talk about at least one of those -- University Hospitals East, where the projected cost was \$3 million and I see the revised cost is \$10.9 million. That's quite a change.

**EMPLOYMENT OF ARCHITECTS/ENGINEERS,
REQUEST FOR CONSTRUCTION BIDS, AND
REPORT OF AWARD OF CONTRACTS (contd)**

Mr. Shkurti:

Mr. McFerson, that certainly raises one's antenna for a question as to why that difference would occur. In that particular case, there are a number of smaller projects that involved renovation and infrastructure at Hospitals East. So rather than do nine separate resolutions, we decided to bundle them all into one resolution. So the cost of the estimate of the project itself, the original \$3 million project, has not increased -- this is just a repackaging of what were several separate projects.

Mr. McFerson:

Perhaps in the future, then, when that's the case, you might put a little asterisk on the projected cost to explain that in advance to answer the question.

Mr. Shkurti:

We will certainly do that.

**EMPLOYMENT OF ARCHITECTS/ENGINEERS,
REQUEST FOR CONSTRUCTION BIDS, AND
REPORT OF AWARD OF CONTRACTS**

Resolution No. 2002-103

JAMES AMBULATORY SERVICES RENOVATIONS
MORRISON TOWER AND SEIBERT HALL FIRE ALARM SYSTEM UPGRADE
UNIVERSITY HOSPITAL/RHODES HALL ENTRANCE
STONE LABORATORY CONCRETE DOCK AND WALK RENOVATION
GRADUATE AND PROFESSIONAL STUDENT HOUSING
UNIVERSITY HOSPITAL EAST MUSCULAR SKELETAL PROGRAM
OSU WETLANDS RESEARCH AND EDUCATION BUILDING
SOUTH CAMPUS HIGH RISE – FIRE ALARM SYSTEM REPLACEMENT

Synopsis: Authorization to employ an architect/engineering firm for the James Ambulatory Services Renovations, Morrison Tower and Seibert Hall Fire Alarm System Upgrade, and Stone Laboratory Concrete Dock and Walk Renovation projects, request construction bids for the James Ambulatory Services Renovations, Morrison Tower and Seibert Hall Fire Alarm System Upgrade, University Hospital/ Rhodes Hall Entrance, and Stone Laboratory Concrete Dock and Walk Renovation project, and acceptance of the report of award of contracts for the Graduate and Professional Student Housing, University Hospitals East Muscular Skeletal Program, OSU Wetlands Research and Education Building, and South Campus High Rise – Fire Alarm System Replacement projects is requested.

WHEREAS the James Cancer Hospital and Solove Research Institute desires to renovate space used by the Ambulatory Surgery Department on the first and second floors and the patient treatment areas on the ground floor; and

WHEREAS the total estimated project cost is \$1,000,000 and the total estimated construction cost is \$750,000, with funding provided by the James Cancer Hospital and Solove Research Institute; and

**EMPLOYMENT OF ARCHITECTS/ENGINEERS,
REQUEST FOR CONSTRUCTION BIDS, AND
REPORT OF AWARD OF CONTRACTS (contd)**

WHEREAS the University desires to replace the existing fire alarm system in Morrison Tower and Siebert Hall with new intelligent photoelectric smoke detectors and audible bases that are fully addressable with fire print based technology and upgraded to be ADA compliant and provide an upgraded intercom system and firefighter phones; and

WHEREAS the total estimated project cost is \$694,949 and the total estimated construction cost is \$583,812, with funding provided by University bond proceeds with debt service paid by Student Affairs; and

WHEREAS the University Hospitals desires to renovate the entrance to Rhodes Hall; and

WHEREAS the total estimated project cost is \$270,000 and the total estimated construction cost is \$ 223,500, with funding provided by University Hospitals; and

WHEREAS at Stone Laboratory on Gibraltar Island the Department of Physical Facilities desires to renovate the boat dock site and walks from the dock area to Cooke Castle including ADA compliance; and

WHEREAS the total estimated project cost is \$63,250 and the total estimated construction cost is \$50,000, with funding provided by House Bill 748 (\$38,362) and House Bill 850 (\$24,888); and

WHEREAS resolutions adopted by the Board of Trustees on September 1, 1999, February 4, 2000, November 3, 2000, and February 2, 2001 authorized the President and/or Vice President for Business and Finance to request construction bids in accordance with established University procedures, and if satisfactory bids were received to award contracts for the following projects:

(* Recommended alternates included in these amounts)

Graduate and Professional Student Housing

This project constructs graduate and professional student apartments in the south campus areas. The total project cost is \$29,172,100; funding is provided by future University bond proceeds with debt service paid by Student Affairs. The estimated completion date is July 2003. The contracts awarded are as follows:

Design:	URS, Columbus, Ohio
General Contract:	Smoot Construction Company of Ohio, Columbus, Ohio
Amount:	\$16,776,600 * +
Estimate:	\$15,402,000 *
Plumbing Contract:	Radico, Inc., Columbus, Ohio
Amount:	\$3,307,700 +
Estimate:	\$3,042,000
HVAC Contract:	Bruner Corporation, Columbus, Ohio
Amount:	\$3,242,000 +
Estimate:	\$3,203,000
Electric Contract:	Superior Electric, Columbus, Ohio
Amount:	\$2,579,000 +
Estimate:	\$2,666,000
Total All Contracts:	\$25,905,300
Contingency Allowance:	\$1,295,265
Total Project Cost:	\$29,172,100

+ The General, Plumbing, HVAC, and Electric Contracts are in excess of the filed estimate of cost; however the total price of all contracts is within 10% of the total estimate of cost and is recommended for award as provided by Section 153.12 of the Revised Code.

**EMPLOYMENT OF ARCHITECTS/ENGINEERS,
REQUEST FOR CONSTRUCTION BIDS, AND
REPORT OF AWARD OF CONTRACTS (contd)**

University Hospitals East Muscular Skeletal Program

This project provides building evaluation, programming, and renovation of the areas of surgery, in-patient, out-patient, and support activities. The total project cost is \$10,900,000; funding is provided by University Hospitals East. The estimated completion date is July 2003. The contracts awarded are as follows:

Design:	URS, Columbus, Ohio
Bid Package # 3 – 5 North Renovation	
General Contract:	Two K General Construction, Columbus, Ohio
Amount:	\$1,307,249 *
Estimate:	\$1,333,877 *
Plumbing Contract:	General Temperature Control, Canal Winchester, Ohio
Amount:	\$493,100 * +
Estimate:	\$335,712 *
HVAC Contract:	Bruner Corporation, Hilliard, Ohio
Amount:	\$337,000 * +
Estimate:	\$265,285 *
Electric Contract:	Buckeye Electric Company, Dayton, Ohio
Amount:	\$259,000 *
Estimate:	\$289,461 *
Bid Package # 6 – Chiller Replacement	
General Contract:	The Altman Company, Columbus, Ohio
Amount:	\$270,000
Estimate:	\$341,000
Combined Plumbing and HVAC Contract:	R. F. Mlasofsky and Company, Delaware, Ohio
Amount:	\$1,393,980 * +
Estimate:	\$1,253,300 *
Electric Contract:	Allen Washington Enterprises, Inc., Columbus, Ohio
Amount:	\$311,000 *
Estimate:	\$363,000 *
Bid Package # 7 – Emergency Power System Upgrade	
General Contract:	Righter Construction Services Inc., Columbus, Ohio
Amount:	\$192,000
Estimate:	\$202,000
Plumbing Contract :	Capital City Mechanical, Inc., Grove City, Ohio
Amount:	\$89,055 +
Estimate:	\$75,000
HVAC Contract :	Pete Miller, Inc., Marion, Ohio
Amount:	\$111,650 +
Estimate:	\$75,000
Electric Contract:	Dynalectric Company of Ohio, Columbus, Ohio
Amount:	\$1,763,100
Estimate:	\$2,550,000
Bid Package # 8 – Elevator Upgrades	
General Contract:	The Altman Company, Columbus, Ohio
Amount:	\$784,871 +
Estimate:	\$715,325
Mechanical Contract:	R. J. Lemmons Inc., Springfield, Ohio
Amount:	\$56,745 +
Estimate:	\$43,400

**EMPLOYMENT OF ARCHITECTS/ENGINEERS,
REQUEST FOR CONSTRUCTION BIDS, AND
REPORT OF AWARD OF CONTRACTS (contd)**

University Hospitals East Muscular Skeletal Program (contd)

Electric Contract:	Knight Electric, Columbus, Ohio
Amount:	\$29,470
Estimate:	\$35,150
Total All Contracts:	\$7,398,220
Contingency Allowance:	\$307,482
Total Project Cost:	\$10,900,000

+ The Bid Package #3 Plumbing and HVAC contracts, Bid Package #6 Combined Plumbing and HVAC contract, Bid Package #7 Plumbing and HVAC contracts, and Bid Package #8 General and Mechanical contracts are in excess of the filed estimate of cost; however the total price of all contracts is within 10% of the total estimate of cost and is recommended for award as provided by Section 153.12 of the Revised Code.

OSU Wetlands Research and Education Building

This project constructs a wetlands research and education facility to serve as catalyst for Ohio to provide national leadership in wetland ecology and management, wetland and river restoration and ecotechnology, and continue the collaboration among several Ohio universities working in these fields. The total project cost is \$2,038,487; funding is provided by Ohio Board of Regents (\$1,180,000) and gifts (\$858,487). The estimated completion date is June 2003. The contracts awarded are as follows:

Design:	NBBJ, Inc., Columbus, Ohio
General Contract:	Righter Construction Services, Columbus, Ohio
Amount:	\$1,108,600 *
Estimate:	\$1,324,000 *
Plumbing Contract:	Capital City Mechanical, Grove City, Ohio
Amount:	\$94,435 * +
Estimate:	\$88,000 *
HVAC Contract:	Martina Metal Contracting Company, Columbus, Ohio
Amount:	\$298,000 * +
Estimate:	\$277,500 *
Electric Contract:	Buckeye Electric Company, Dayton, Ohio
Amount:	\$138,500 *
Estimate:	\$171,000
Total All Contracts:	\$1,639,535
Contingency Allowance:	\$163,953
Total Project Cost:	\$2,038,487

+ The Plumbing and HVAC contracts are in excess of the filed estimate of cost; however the total price of all contracts is within 10% of the total estimate of cost and is recommended for award as provided by Section 153.12 of the Revised Code.

South Campus High Rise – Fire Alarm System Replacement

This project replaces the existing fire alarm system in Steeb, Smith, Park and Stradley Halls with new intelligent photoelectric smoke detectors and audible bases that are fully addressable with fire-print based technology. The total project cost is \$1,541,760; funding is provided by future bond proceeds with debt service paid by Student Affairs. The estimated completion date is December 2002. The contracts awarded are as follows:

**EMPLOYMENT OF ARCHITECTS/ENGINEERS,
REQUEST FOR CONSTRUCTION BIDS, AND
REPORT OF AWARD OF CONTRACTS (contd)**

South Campus High Rise – Fire Alarm System Replacement (contd)

Design:	W. E. Monks, Columbus, Ohio
Electric Contract:	Superior Electric, Columbus, Ohio
Amount:	\$1,063,900 *
Estimate:	\$1,394,036 *
Total All Contracts:	\$1,063,900
Contingency Allowance:	\$366,893
Total Project Cost:	\$1,541,760

NOW THEREFORE

BE IT RESOLVED, That the President and/or Senior Vice President for Business and Finance be authorized to select qualified architectural/engineering firms as necessary for the James Ambulatory Services Renovations, Morrison Tower and Seibert Hall Fire Alarm System Upgrade, and Stone Laboratory Concrete Dock and Walk Renovation projects and that the fees for these services be negotiated between the firms selected and the University; and

BE IT FURTHER RESOLVED, That the President and/or Senior Vice President for Business and Finance be authorized to request construction bids for the James Ambulatory Services Renovations, Morrison Tower and Seibert Hall Fire Alarm System Upgrade, University Hospital/Rhodes Hall Entrance, and Stone Laboratory Concrete Dock and Walk Renovation projects in accordance with established University and State of Ohio procedures, and if satisfactory bids are received, to issue contracts with all actions to be reported to this Board at the appropriate time; and

BE IT FURTHER RESOLVED, That pursuant to the actions previously authorized by the Board, the report of award of contracts and establishment of contingency funds for the Graduate and Professional Student Housing, University Hospitals East Muscular Skeletal Program, OSU Wetlands Research and Education Building, and South Campus High Rise – Fire Alarm System Replacement projects is hereby accepted.

(See Appendix XXXVI for background information and maps, page 1023.)

**SALE OF LAND AND GRANT OF TEMPORARY CONSTRUCTION LICENSES
TO THE CITY OF COLUMBUS**

Mr. Shkurti:

Mr. Chairman, the next resolution involves the sale of land to the City of Columbus for the Lane Avenue widening. At its August 2001 meeting, the Board approved granting permanent and temporary licenses to Franklin County for the Lane Avenue bridge replacement project, which we've discussed before. In fact, there was a groundbreaking ceremony in late February for that project.

At this time, we are requesting authorizations to sell University property to the City of Columbus for the project to widen Lane Avenue in conjunction with the bridge replacement. This project represents an important partnership between the city and the University and I want to take a moment to thank President Kirwan for his leadership on this project, and also Mayor Coleman, because this required a great deal of cooperation between the city and the University.

**SALE OF LAND AND GRANT OF TEMPORARY CONSTRUCTION LICENSES
TO THE CITY OF COLUMBUS (contd)**

Mr. Shkurti: (contd)

This partnership will result in needed enhancements to the Lane Avenue streetscape to make it more pedestrian-friendly and also to recognize its importance to the University and the community. We, the University, will contribute the value of our right-of-way, and the city will contribute substantial funds, as well as provide a total of \$1.5 million to bury the utility lines and provide decorative street lighting, street trees, and irrigation for them, as well as to widen sidewalks. All of this will greatly improve the quality of this area of campus. We're recommending this resolution for your approval.

Mr. Patterson:

Any questions on this resolution?

Mr. McFerson:

Will Lane Avenue have to close down while this takes place?

Mr. Shkurti:

Mr. McFerson, not totally. I believe a portion of Lane Avenue will remain open, but we'll be much more constricted in that area. We are engaged in a number of projects to be ready in the fall to educate motorists and people coming in and out of campus about how to negotiate that whole area.

Mr. McFerson:

So it will be closed during football season?

Mr. Shkurti:

Unfortunately, there will be some issues during football season. We are anticipating that will be a challenge to manage that traffic.

Mr. McFerson:

It will be nice to have it widened.

Mr. Shkurti:

It's one of those things that will be a royal pain in the process, but when it's done, everyone will recognize the benefits -- assuming we survive the interim period.

Ms. Jill Morelli:

I would like to clarify one thing, the bridge will be closed for about a year and three months total. However, we will maintain access to the individual businesses and our own usage along Lane Avenue during construction, but the bridge will be shut down right after football season. If you have driven in that area recently, you can see that they've already started working on it. They have the fence up and they have the dredger down in the river. So that work has begun and the bridge will be closed after the football season this year.

**SALE OF LAND AND GRANT OF TEMPORARY CONSTRUCTION LICENSES
TO THE CITY OF COLUMBUS (contd)**

Ms. Longaberger:

This creates an additional problem -- with the roads being closed on I-670 and St. Rt. 315, and now adding Lane Avenue to that will be quite exciting.

Mr. Shkurti:

Yes, it will. The only consolation I can offer is that if you live in Columbus you know the bridges are being replaced, starting from the south going north. The Third Avenue bridge was replaced and then the Fifth Avenue bridge. The experience has been -- although the Lane Avenue bridge is a little more central to us than the others -- is that once people adapt to the fact that there is a change in their routines, things tend to settle down.

The two additional challenges we're going to have is, of course, the critical role of the Lane Avenue bridge to our campus and then, secondly, the rather unique challenge we have with football traffic and the number of people that descend on this area at any one given time. I would say if the University's established recognition of best in class, it has been managing football traffic. This will certainly challenge us and we're going to need everybody's help in cooperation and patience, but we're up to the task. We're going to need to continue to work on it. If the Board would like a briefing before the fall on what our plans are in terms of dealing with the congestion and the problems, we'd be glad to do that.

Mrs. Davidson:

We just want to know what phone number to give when we get the calls.

Mr. Shkurti:

I would say at that time, the acting president would be a good number to call. We will attempt to be proactive, Mrs. Davidson. We do not want our elected representatives, in particular, to feel disadvantaged by our behavior.

Mr. Filiatraut:

Do you anticipate sending something out to students who will be applying to school here or those that might be visiting, of ways to get around this traffic? I know when you're coming down St. Rt. 315 that is the exit that says "Ohio State University," so everyone's going to get off there but they won't know where to go.

Mr. Shkurti:

Kevin, I know there is a major effort going forward to do a total communications and preparation effort. I know Jill is involved in that. Jill, is there anything you would like to add?

Ms. Morelli:

We've setup an advisory board, we have a website to show people how to get on campus, and we are using communications personnel to assist us in identifying areas where we're going to need to have the most up-to-date information in the right place. Having a daughter who has recently gone off to college, I know the importance of that website and how do you get to campus.

We've identified the people on the advisory board, but they haven't met yet because we haven't reached that point yet of that "need to know." We're very

**SALE OF LAND AND GRANT OF TEMPORARY CONSTRUCTION LICENSES
TO THE CITY OF COLUMBUS (contd)**

Ms. Morelli: (contd)

cognizant of the wide range of visitors to our campus. We're also understanding that those visitors have a wide range of needs as to how they receive information. We're trying to determine the numbers and kinds of information and the ways they get it delivered to them so that we don't miss anyone.

One of things we found most important is that people are setting up conferences now for a year from now. As a consequence, we have to be anticipating that as they put their materials together. So there is a wide variety of medium methods we're using, as well as the recipients that we are targeting.

Mr. Filiatraut:

Thank you.

**SALE OF LAND AND GRANT OF TEMPORARY CONSTRUCTION LICENSES
TO THE CITY OF COLUMBUS**

Resolution No. 2002-104

**LANE AVENUE ROAD WIDENING PROJECT
APPROXIMATELY NINE ACRES ON LANE AVENUE, COLUMBUS, OHIO**

Synopsis: Authorization to grant temporary construction licenses for approximately two acres, and sell approximately seven acres, to the City of Columbus for the purpose of widening Lane Avenue between Olentangy River Road and High Street is proposed.

WHEREAS the Ohio State University owns land along Lane Avenue between Olentangy River Road and High Street, and

WHEREAS the City of Columbus desires to purchase seven acres and to have temporary access for construction purposes to an additional two acres of University property for the purposes of road widening, the installation of streetscape enhancements and related improvements, and related construction and permanent right-of-way, and

WHEREAS the City and the University have joined in a cooperative partnership to jointly fund significant streetscape enhancements for this important road project to benefit the University, the University community and the City; and

WHEREAS the appraised value of the property desired by the City on the south side of Lane Avenue is \$1,143,000 and the City has agreed to credit the University \$1,080,000 for the value of the University property needed for the project and to contribute \$400,000, so that the total amount dedicated to enhancements for the project is \$1,480,000; and

WHEREAS the appraised value of the property desired by the City on the north side of Lane Avenue is \$25,850, to be provided by the City in conventional consideration, and

WHEREAS the appropriate University offices have determined that the sale of property and the granting of temporary licenses requested by the City is in the best interest of the University:

NOW THEREFORE

**SALE OF LAND AND GRANT OF TEMPORARY CONSTRUCTION LICENSES
TO THE CITY OF COLUMBUS (contd)**

BE IT RESOLVED, That the President and/or the Senior Vice President for Business and Finance be authorized to sell and grant temporary licenses under ORC 3345.18, for the property described herein, giving temporary and permanent real property rights to the City of Columbus for the proposes of widening Lane Avenue, installing streetscape enhancements, and for making related improvements to the surrounding areas.

(See Appendix XXXVII for background information and maps, page 1039.)

**2002-2003 TUITION INCREASES
ATI, REGIONAL CAMPUSES, AND NON-RESIDENT SURCHARGE**

Mr. Shkurti:

The final resolution deals with tuition and fees in a couple of categories. As I'm sure you recall, last month we asked you to approve the resident undergraduate fees for the Columbus campus for this coming fall. In this resolution today, we're asking you to approve the resident undergraduate fees for the Regional Campuses and ATI, as well as the out-of-state surcharge for undergraduate students. At the June meeting, we will present to you the recommendations for fees for graduate and professional students.

In terms of the regional tuition fees, there are really three issues that complicate this somewhat, and I'll try and make it as clear as possible. We have, obviously, the normal increase in tuition and fees. We're also struggling with a cut in a state line item called the Access Challenge, which does not apply to the Columbus Campus, but which does to the Regional Campuses. It is, in essence, a buy-down, if you will, of their normal tuition rates and is a form of student financial aid. This was reduced along with other state line items and, at the time the program was implemented, it was agreed that the Regional Campuses would reduce their fees by a certain amount, but if the money was ever reduced that would have to be made up in some way.

The third element that complicates this a little bit is that although the Regional Campuses are an important part of OSU and a part of our mission, their mission is slightly different because they also have an access mission. All of us as public institutions do that, but on the Regional Campuses part of that translates into what, at least over recent years, have been historically lower fees.

So in trying to balance all this, the Regional Campus deans and their boards discussed this for some time and have come forward with a proposal that we support, and we're presenting to you today. I want to acknowledge in the audience John Riedl, dean of the Mansfield Campus and executive dean of the Regional Campuses, and Bob Moser, vice president for Food, Agricultural, and Environmental Sciences, to whom ATI reports.

First, in regarding the Regional Campuses, what we're proposing is that for lower level students – lower meaning in terms of class rank, or freshman or sophomores – that their tuition for the academic year be increased from \$3,606 to \$3,927, or about a \$321 increase. That is something a little over eight percent.

For upper level students, which would be junior and seniors, the increase goes from \$3,870 to \$4,365 – a \$495 increase – and that translates to something close to 12 percent.

**2002-2003 TUITION INCREASES
ATI, REGIONAL CAMPUSES, AND NON-RESIDENT SURCHARGE (contd)**

Mr. Shkurti: (contd)

The reason for that difference is a commitment on our part and the Regional Campuses' part to try to reduce the financial barriers to access as much as possible, particularly to new students who would be coming into the system. This is somewhat difficult, given the budget reductions that I mentioned earlier, but this at least has a lower increase for them. For the upper level students who are already in the system and who we want to encourage eventually to transfer to Columbus, the thinking is to try to not have too great of a difference between the tuition those students would pay and what they would pay at the Columbus Campus should they transfer here. We don't want financial reasons to be a disincentive to transfer.

A larger issue that this raises as we move to the future -- and the OSU Columbus Campus continues to be selective in its admissions and the Regional Campuses to be more open in their admissions and we have different tuition levels, but they're all part of OSU -- is how this all fits together. As you know, there's a Regional Campus Commission that some of you as Trustees are members of and that Bob Moser is chairing. That Commission will be reporting later in the spring about the longer run issues involving the Regional Campuses. But we thought it was important that students who would attend our Regional Campuses know what their fees are going to be in the fall. So that's why we're asking you to vote on fees at least for next year at this point in time.

The other element that's in here, as well, is the Agricultural Technical Institute at Wooster. They've handled the Access Challenge differently. It's a two-year program so their increases are pretty much across-the-board at about nine percent. As President Kirwan mentioned in his introductory remarks, we feel this is consistent with the understanding we've reached with the Governor regarding tuition for the fall.

Let me turn now to the out-of-state surcharge. I want to emphasize first that out-of-state students pay the exact same increase in their base fees as our resident students do. So the out-of-state surcharge is a charge on top of what the resident students pay. The reason for that is that we receive state taxpayer support for resident undergraduates; we do not for out-of-state students. Yet these out-of-state students are an important part of the educational experience here. They are highly qualified students, they provide a good portion of our diversity requirements, and they also enrich our programs. So we try to set our fees for these out-of-state students at a level that recognizes we aren't receiving state support -- so we're fair to the taxpayers of the state -- but also that they aren't so high that they become a discouragement for us to attract these students.

So what we're recommending in this particular case is an increase of 7.5 percent in the surcharge. So in addition to the increase all the in-state students are paying, the surcharge that they're paying would be increased an additional 7.5 percent. Normally, we do this at five percent. But we felt this year, because of the challenge we had in closing the \$6 million gap that we talked about last month, and because our fees for our resident out-of-state students were lagging a little bit behind what our competitors were doing, that we could recommend an increase of this size this year and still meet our enrollment goals and still be fair to these students. So this means that for a current out-of-state student who is paying currently \$13,527 for an academic year in tuition and fees, their fees would go up to \$14,613. That is their total fee -- both the base fees all students pay and the surcharge. So that's an increase of \$1,086.

**2002-2003 TUITION INCREASES
ATI, REGIONAL CAMPUSES, AND NON-RESIDENT SURCHARGE (contd)**

Mr. Shkurti: (contd)

Again, the rate for all students this year is \$13,527. If you recall, we have approved a differential increase for new students and for these new students their tuition and fees would go up to \$15,087. That is an increase of \$1,560. That is a fairly hefty increase but, again, we feel that by the University being as attractive as it is and also in carefully managing our student financial aid, that we will be able to meet our enrollment and diversity targets regarding out-of-state students, yet have some additional income to the tune of about \$1million than we otherwise would if these recommendations are accepted.

We think these recommendations balance our need for financial resources to meet our academic goals, yet are consistent with our goals regarding access for both the Regional Campuses and the Columbus Campus. We recommend they be approved, and I'll be glad to answer any questions members of the Board may have about that.

Mr. Patterson:

Are there any further questions for Bill? Dimon --

Mr. McFerson:

Mr. Shkurti, you mentioned new students this fall -- I think the resolution says starting this summer.

Mr. Shkurti:

That is absolutely correct, and the same is true for resident students. We had so many different variations of that sometimes my brain got behind the final decision.

Mr. Patterson:

Any other questions? If not, Mr. Chairman, I'll move approval of these three resolutions as part of the Fiscal Affairs Committee.

**2002-2003 TUITION INCREASES
ATI, REGIONAL CAMPUSES, AND NON-RESIDENT SURCHARGE**

Resolution No. 2002-105

Synopsis: Instructional and General fees for undergraduate students enrolled at ATI and the Regional Campuses and the Non-resident Surcharges for undergraduate students enrolled at all campuses for Fiscal Year 2002-2003 are proposed effective Summer Quarter 2002.

WHEREAS the Board of Trustees of The Ohio State University, at their March 1, 2002 meeting, approved Instructional and General fees for undergraduate students enrolled at the Columbus Campus for the Fiscal Year 2002-2003 effective Summer Quarter 2002; and

WHEREAS the State has provided Access Challenge funding to the Agricultural Technical Institute (ATI) and the Regional Campuses, and the Regional Campuses wish to allocate a greater portion of those funds to lower-division students than in the past in accordance with the purpose of those funds; and

**2002-2003 TUITION INCREASES
ATI, REGIONAL CAMPUSES, AND NON-RESIDENT SURCHARGE (contd)**

WHEREAS ATI and the Regional Campuses wish to keep the average increase in all of their undergraduate Instructional and General fees net of Access Challenge for Fiscal Year 2002-2003 at under 10% and also wish to implement these increases effective Summer Quarter 2002; and

WHEREAS the Board of Trustees supports the tuition strategy and recommendations made by the Executive Dean of the College of Food, Agricultural, and Environmental Sciences for ATI and jointly by the Boards of Trustees of the Regional Campuses; and

WHEREAS it is necessary now to set the Undergraduate Non-resident surcharges, which are the same at all campuses, for Fiscal Year 2002-2003 in order to be effective for Summer Quarter 2002; and

WHEREAS the tuition rates to be adopted are specifically based on the current level of State support and could be modified if State support for higher education is either increased or decreased; and

WHEREAS consultations continue to take place with regard to professional college fees and those fees will be determined as part of the regular 2002-2003 budget process and will be effective Autumn Quarter 2002:

NOW THEREFORE

BE IT RESOLVED, That effective Summer Quarter 2002, Fiscal Year 2002-03 Instructional and General Fees for undergraduate students enrolled at ATI, net of Access Challenge credits, be increased by 9.9% (\$119 per quarter for a full-time student); and

BE IT FURTHER RESOLVED, That effective Summer Quarter 2002, the Fiscal Year 2002-2003 Instructional and General Fees for undergraduate students enrolled at the Regional Campuses be increased by 8.0% (\$112 per quarter for a full-time student) and that these fees be reduced by Access Challenge credits for lower-division students by \$200 per quarter for full-time students for a net increase of 8.9% (\$107 per quarter), and for upper-division students by \$54 per quarter for full-time students for a net increase of 12.8% (\$165 per quarter), with the average for all students at just under 10%; and

BE IT FURTHER RESOLVED, That effective Summer Quarter 2002, the Fiscal Year 2002-2003 Non-resident surcharge for undergraduate students enrolled at all campuses be increased by 7.5% (\$219 per quarter for a full-time student).

(See Appendix XXXVIII for background information, page 1043.)

Upon motion of Mr. Patterson, seconded by Mr. McFerson, the Board of Trustees adopted the foregoing resolutions by unanimous roll call vote, cast by Messrs. Brennan, Patterson, Sofia, Slane, McFerson, and Judge Duncan, Meses. Longaberger, Hendricks, and Davidson.

--0--

EXECUTIVE SESSION

Mr. Brennan:

At this time, I will entertain a motion to go into Executive Session to consider a Personnel Action that is confidential under the *Medical Staff Bylaws*.

Upon motion of Mrs. Davidson, seconded by Ms. Hendricks, the Board of Trustees recessed into Executive Session with five affirmative votes cast by Messrs. Brennan, Patterson, Sofia, McFerson, and Judge Duncan. [Judge Duncan did not participate in the Executive Session.]

Mr. Brennan:

The meeting of the Board of Trustees will now reconvene. The Board recommends that the Personnel Actions resolution before this Board today be amended to include the confidential action discussed in Executive Session.

AMENDED PERSONNEL ACTIONS

Resolution No. 2002-106

BE IT RESOLVED, That the personnel actions as recorded in the Personnel Budget Records of the University since the March 1, 2002 meeting of the Board, including the following Appointments/Reappointment, Promotions, Reappointment of Chairperson, Leaves of Absence Without Salary, Professional Improvement Leaves, and Emeritus Titles, as detailed in the University Budget be approved; and

BE IT FURTHER RESOLVED, That the Medical Staff Appointments (The Ohio State University Medical Center and The Ohio State University Hospitals-East) approved February 21, 2002, by The Ohio State University Hospitals Board, and the Medical Staff Appointments approved March 19, 2002, by The James Cancer Hospital Board, be ratified, and that revocation of Clinical Privileges at The Arthur G. James Cancer Hospital and Richard J. Solove Research Institute, considered at today's Executive Session of the Board, be approved.

Appointments

Name: KAREN A. BELL
Titles: Dean and Professor
College: The Arts
Term: May 1, 2002, through June 30, 2007
Present Position: Interim Dean, College of The Arts

Name: DEV S. PATHAK
Title: Interim Dean for Public Health
College/School: Medicine and Public Health/School of Public Health
Term: June 1, 2002 through June 30, 2003
Present Position: Director, Health Sciences Administration and Professor, School of Public Health and Department of Marketing

Name: JOHN A. POWELL
Titles: Director and Professor (The Gregory H. Williams Chair in Civil Rights and Civil Liberties)
Institute/College: The Institute for the Study of Race and Ethnicity in the Americas/The Michael E. Moritz College of Law
Term/Effective: January 15, 2003 through June 30, 2006/January 15, 2003
Present Position: Executive Director of the Institute on Race and Poverty and the Earl R. Larson Chair in Civil Rights and Civil Liberties, University of Minnesota Law School

Name: TODD I. STEWART
Title: Director of the Program for International and Homeland Security
Office: Research Administration
Term: April 1, 2002 through March 31, 2007
Previous Position: Major General, United States Air Force, Wright-Patterson Air Force Base, OH

Name: MARTHA CHAMALLAS
Title: Professor (The Robert J. Lynn Chair in Law)
College: The Michael E. Moritz College of Law
Effective: August 16, 2002
Present Position: Professor, University of Pittsburgh, School of Law, Pittsburgh, PA

AMENDED PERSONNEL ACTIONS (contd)

Appointments (contd)

Name: JOSHUA DRESSLER
Title: Professor (The Frank R. Strong Chair in Law)
College: The Michael E. Moritz College of Law
Effective: April 1, 2002
Present Position: Professor (The Edwin M. Cooperman Designated Professorship in Law)

Promotion

Name: ERIC R. KUNZ
Title: Associate Vice President for Health Sciences
Office: Health Sciences
Effective: March 11, 2002
Present Position: Chief Administrative and Planning Officer, OSU Health System

Reappointment

Name: JERALD GREENBERG
Title: Professor (The Irving Abramowitz Memorial Professorship)
College: The Max M. Fisher College of Business
Term: March 1, 2002 through February 28, 2007

Reappointment of Chairperson

October 1, 2002 through September 30, 2006

Linguistics

Peter W. Culicover

Leaves of Absence Without Salary

ROY JOSHUA, Associate Professor, Department of Mathematics, effective Autumn Quarter 2002, Winter Quarter and Spring Quarter 2003, to accept a Distinguished Visiting Professorship at Miami University, Oxford, Ohio.

KUNAL SAHA, Assistant Professor, Department of Pediatrics, effective February 22, 2002 through August 31, 2002, for personal reasons.

Professional Improvement Leaves

PETER W. CULICOVER, Chairperson and Professor, Department of Linguistics, effective Autumn Quarter 2003.

BARBARA BECKER-CANTARINO, Professor, Department of Germanic Languages and Literatures, effective Spring Quarter and Autumn Quarter 2003, and Winter Quarter 2004.

MARY E. BECKMAN, Professor, Department of Linguistics, effective Autumn Quarter 2002, Winter Quarter and Spring Quarter 2003.

MICHAEL L. BENEDICT, Professor, Department of History, effective Autumn Quarter 2002, Winter Quarter and Spring Quarter 2003.

ERIC A. BRAATEN, Professor, Department of Physics, effective Autumn Quarter 2002, Winter Quarter and Spring Quarter 2003.

SALVADOR G. CASTANEDA, Professor, Department of Spanish and Portuguese, effective Autumn Quarter 2002, Winter Quarter and Spring Quarter 2003.

AMENDED PERSONNEL ACTIONS (contd)

Professional Improvement Leaves (contd)

MALCOLM H. COCHRAN, Professor, Department of Art, effective Autumn Quarter 2002, Winter Quarter and Spring Quarter 2003.

THOMAS COOLEY, Professor, Department of English, effective Summer Quarter 2002.

MICHAEL W. DAVIS, Professor, Department of Mathematics, effective Autumn Quarter 2002, Winter Quarter and Spring Quarter 2003.

GREGORY JUSDANIS, Professor, Department of Greek and Latin, effective Autumn Quarter 2002, Winter Quarter and Spring Quarter 2003.

TEN-HWANG LAI, Professor, Department of Computer and Information Science, effective Autumn Quarter 2002, Winter Quarter and Spring Quarter 2003.

JUNE K. LEE, Professor, Department of Mechanical Engineering, effective Autumn Quarter 2002, Winter Quarter and Spring Quarter 2003.

JOHN C. LIPPOLD, Professor, Department of Industrial, Welding, and Systems Engineering, effective Winter Quarter and Spring Quarter 2003.

MICHAEL J. MORAN, Professor, Department of Mechanical Engineering, effective Winter Quarter and Spring Quarter 2003.

RANDOLPH L. MOSES, Professor, Department of Electrical Engineering, effective Autumn Quarter 2002, Winter Quarter and Spring Quarter 2003.

HITAY OZBAY, Professor, Department of Electrical Engineering, effective Autumn Quarter 2002, Winter Quarter and Spring Quarter 2003.

MARC E. POSNER, Professor, Department of Industrial, Welding and Systems Engineering, effective Autumn Quarter 2002, Winter Quarter and Spring Quarter 2003.

STEPHEN J. RALLIS, Professor, Department of Mathematics, effective Autumn Quarter 2002, Winter Quarter and Spring Quarter 2003.

ANTON F. SCHENK, Professor, Department of Civil and Environmental Engineering and Geodetic Science, effective Autumn Quarter 2002, Winter Quarter and Spring Quarter 2003.

MICHEL P. TALAGRAND, Professor, Department of Mathematics, effective Autumn Quarter 2002, Winter Quarter and Spring Quarter 2003.

THOMAS M. YORK, Professor, Department of Aerospace Engineering and Aviation, effective Autumn Quarter 2002, Winter Quarter and Spring Quarter 2003.

MARC C. AINGER, Associate Professor, School of Music, effective Autumn Quarter 2002, Winter Quarter and Spring Quarter 2003.

TIMOTHY J. CARLSON, Associate Professor, Department of Mathematics, effective Autumn Quarter 2002, Winter Quarter and Spring Quarter 2003.

E. JUSTIN D'ARMS, Associate Professor, Department of Philosophy, effective Autumn Quarter 2002, Winter Quarter and Spring Quarter 2003.

JOHN E. DAVIDSON, Associate Professor, Department of Germanic Languages and Literatures, effective Autumn Quarter 2002, Winter Quarter and Spring Quarter 2003.

AMENDED PERSONNEL ACTIONS (contd)

Professional Improvement Leaves (contd)

YANN G. GUEZENNEC, Associate Professor, Department of Mechanical Engineering, effective Autumn Quarter 2002, Winter Quarter and Spring Quarter 2003.

GEORG R. HEIMDAL, Associate Professor, Department of Art, effective Autumn Quarter 2002, Winter Quarter and Spring Quarter 2003.

GREGOR W. HENS, Associate Professor, Department of Germanic Languages and Literatures, effective Autumn Quarter 2002, Winter Quarter and Spring Quarter 2003.

JOEL T. JOHNSON, Associate Professor, Department of Electrical Engineering, effective Autumn Quarter 2002 and Winter Quarter 2003.

KAY B. JONES, Associate Professor, Austin E. Knowlton School of Architecture, effective Autumn Quarter 2002, Winter Quarter and Spring Quarter 2003.

ETHAN E. H. KNAPP, Associate Professor, Department of English, effective Autumn Quarter 2002.

FERNANDO MARTINEZ-GIL, Associate Professor, Department of Spanish and Portuguese, effective Spring Quarter 2003.

CARLA G. PESTANA, Associate Professor, Department of History, effective Autumn Quarter 2002, Winter Quarter and Spring Quarter 2003.

CLAIRE C. ROBERTSON, Associate Professor, Departments of History and Women's Studies, effective Autumn Quarter 2002, Winter Quarter and Spring Quarter 2003.

ESTHER B. SULLIVAN, Associate Professor, Department of Theatre, effective Autumn Quarter 2002, Winter Quarter and Spring Quarter 2003.

JAMES E. TITTLE, Associate Professor, Department of Psychology, effective Autumn Quarter 2002, Winter Quarter and Spring Quarter 2003.

SUSAN S. WILLIAMS, Associate Professor, Department of English, effective Spring Quarter 2003.

Emeritus Titles

EDWARD H. JENNINGS, Office of the Board of Trustees, with the title President Emeritus, effective April 1, 2002.

A. JOHN ARNFIELD, Department of Geography, with the title Professor Emeritus, effective July 1, 2002.

KARIN L. DAHL, School of Teaching and Learning, with the title Professor Emeritus, effective July 1, 2002.

WALTER A. DAVIS III, Department of English, with the title Professor Emeritus, effective April 1, 2002.

JOSEPH C. FERRAR, Department of Mathematics, with the title Professor Emeritus, effective July 1, 2002.

JAMES C. PAPRITAN II, Department of Food, Agricultural, and Biological Engineering, with the title Professor Emeritus, effective April 1, 2002.

AMENDED PERSONNEL ACTIONS (contd)

Emeritus Titles (contd)

LARRY W. ROBERTSON, College of Pharmacy, with the title Professor Emeritus, effective April 1, 2002.

YUNG-CHEN LU, Department of Mathematics, with the title Associate Professor Emeritus, effective July 1, 2002.

MARTIN LUBOW, Department of Ophthalmology, with the title Associate Professor Emeritus, effective April 1, 2002.

Medical Staff Appointments (The Ohio State University Medical Center)

February 2002

Harold E. Cook, III, M.D., Anesthesiology, Attending, 02/21/2002-06/30/2003

Galina T. Dimitrova, M.D., Anesthesiology, PGY4 Limited, 01/22/2002-06/30/2003

Kevin G. Kegler, M.D., Ophthalmology, Courtesy, 02/21/2002-06/30/2003

Bradley A. Lisko, M.D., Pediatrics, Courtesy, 02/21/2002-06/30/2003

Wendy S. Manko, D.O., Obstetrics and Gynecology, PGY4 Limited (Rotating), 03/25/2002-04/30/2002

Yaser Ramadan, M.D., Psychiatry, Attending, 02/21/2002-06/30/2002

Bushra Siddiqi, M.D., Family Medicine, Attending, 03/01/2002-06/30/2002

John Keith Thompson, D.O., Surgery, PGY4 Limited (Rotating), 03/01/2002-03/31/2002

Mark J. Triffon, M.D., Orthopedic Surgery, Community Affiliate Physician, 02/21/2002-06/30/2002

Requests for Additional or Special Privileges (The Ohio State University Medical Center)

February 2002

Mark Angelos, M.D., Emergency Medicine, Attending, Moderate and Deep Sedation, 02/21/2002-06/30/2003

David Bahner, M.D., Emergency Medicine, Attending, Moderate and Deep Sedation, 02/21/2002-06/30/2003

Leo Boggs, M.D., Emergency Medicine, Attending, Moderate and Deep Sedation, 02/21/2002-06/30/2003

William Burak, M.D., Surgery, Attending, E.G.D., 02/21/2002-06/30/2003

Harold E. Cook III, M.D., Anesthesiology, Attending, All advanced pain procedures (except denervation by cryothermyablation), Intraspinal catheter placement, 02/21/2002-06/30/2003

Emile El-Shammaa, M.D., Emergency Medicine, Attending, Moderate and Deep Sedation, 02/21/2002-06/30/2003

Thomas Gavin, M.D., Emergency Medicine, Attending, Moderate and Deep Sedation, 02/21/2002-06/30/2003

Diane Gorgas, M.D., Emergency Medicine, Attending, Moderate and Deep Sedation, 02/21/2002-06/30/2003

Brian Hiestand, M.D., Emergency Medicine, Attending, Moderate and Deep Sedation, 02/21/2002-06/30/2003

James Hoekstra, M.D., Emergency Medicine, Attending, Moderate Sedation, 02/21/2002-06/30/2003

Kevin Kegler, M.D., Ophthalmology, Courtesy, Lasers (Argon and Ophthalmic Yag), 02/21/2002-06/30/2003

Craig Key, M.D., Emergency Medicine, Attending, Moderate and Deep Sedation, 02/21/2002-06/30/2003

Sorabh Khandelwal, M.D., Emergency Medicine, Attending, Moderate and Deep Sedation, 02/21/2002-06/30/2003

Carolyn Lugannani-Guarino, M.D., Family Medicine, Attending, Obstetrical Ultrasound, 02/21/2002-06/30/2003

AMENDED PERSONNEL ACTIONS (contd)

Requests for Additional or Special Privileges (The Ohio State University Medical Center) (contd)

February 2002 (contd)

Daniel R. Martin, M.D., Emergency Medicine, Attending, Moderate and Deep Sedation, 02/21/2002-06/30/2002
Richard N. Nelson, M.D., Emergency Medicine, Attending, Moderate and Deep Sedation, 02/21/2002-06/30/2002
Douglas Rund, M.D., Emergency Medicine, Attending, Moderate and Deep Sedation, 02/21/2002-06/30/2002
Bushra Siddiqi, M.D., Family Medicine, Attending, Culposcopy, Biopsy, C.V. Line Placement, 03/01/2002-6/30/2002
Howard Werman, M.D., Emergency Medicine, Attending, Moderate and Deep Sedation, 02/21/2002-06/30/2002

Medical Staff Appointments (The Ohio State University Hospitals East)

February 2002

Doreen M. Agnese, M.D., Surgery, Fellow 1st Year, Limited, 02/21/2002-06/30/2003
Jan S. Augenstein, PA-C, Orthopaedic Surgery, Allied Health, 02/21/2002-06/30/2003
Robert A. Baiocchi, Ph.D, M.D., Internal Medicine, Limited, 02/21/2002-06/30/2003
Kurt A. Berlekamp, PA-C, Orthopaedic Surgery, Allied Health, 02/21/2002-06/30/2003
Jeffrey M. Fowler, M.D., Surgery, Courtesy, 02/21/2002-06/30/2003
Osita E. Okpalaoka, M.D., Internal Medicine, Active, 02/21/2002-06/30/2002
Mary E. Taylor, PA-C, Internal Medicine, Allied Health, 02/21/2002-06/30/2002
Mark J. Triffon, M.D., Orthopaedic Surgery, Active, 02/12/2002-06/30/2002

Medical Staff Appointments (The Arthur G. James Cancer Hospital and Richard J. Solove Research Institute)

February/March 2002

Brian P. Biernat, M.D., Internal Medicine, Dermatology, Clinical Assistant Professor, Clinical Attending
Harold E. Cook III, M.D., Anesthesiology, Clinical Assistant Professor, Associate Attending
M. Farid Edwards, M.D., Anesthesiology, Clinical Assistant Professor, Associate Attending
Gregory E. Guy, M.D., Radiology, Assistant Professor, Associate Attending
John E. Hohmann, M.D., Anesthesiology, Clinical Assistant Professor, Clinical Attending
John S. Rogoski, D.O., Anesthesiology, Clinical Assistant Professor, Associate Attending
Dawn M. Salvatore, M.D., Surgery, General Surgery, Assistant Professor, Associate Attending
G. Todd Schulte, M.D., Anesthesiology, Clinical Assistant Professor, Associate Attending

Full Appointments – Faculty

Eric Bourekas, M.D., Associate Attending, Radiology
Stephen Burgun, M.D., Associate Attending, Endocrinology
Rama Jayanthi, M.D., Clinical Attending, Urology
Kari Kendra, M.D., Ph.D., Attending, Internal Medicine, Hematology/Oncology
Vivek Kadyan, M.D., Associate Attending, Physical Medicine and Rehabilitation
Stephen Pivoski, M.D., Attending, Surgical Oncology
Daniela Proca, M.D., Associate Attending, Pathology
Nilsa Del Carmen Ramirez-Milan, M.D., Associate Attending, Pathology
Larry Tate, M.D., Associate Attending, Pathology
Eric Ward, M.D., Associate Attending, Urology
Alvin Wee, D.D.S., Associate Attending, Dentistry

AMENDED PERSONNEL ACTIONS (contd)

Medical Staff Appointments (The Arthur G. James Cancer Hospital and Richard J. Solove Research Institute) (contd)

February/March 2002 (contd)

Reappointment – Community Oncologist Attending

Elaine Beed, M.D., Internal Medicine, Hematology/Oncology

Additional Privileges Requested

Amit Agrawal, M.D., Otolaryngology, moderate conscious sedation

Honorary Medical Staff Appointment

David Botstein, Ph.D., Stanford University School of Medicine

Upon motion of Mrs. Davidson, seconded by Mr. Sofia, the Board of Trustees adopted the foregoing resolution with eight affirmative votes cast by Messrs. Brennan, Patterson, Sofia, Slane, McFerson, and Ms. Longaberger, Hendricks, and Davidson, and an abstention cast by Judge Duncan.

--0--

STUDENT RECOGNITION AWARD

Mr. Shultz:

Ladies and gentlemen and members of the Board, from time to time the Board of Trustees has the opportunity to put a face on academic excellence through our Student Recognition program. Nominated by the dean of the College of Social and Behavioral Sciences, we are proud to recognize Michelle Kiracofe today, an undergraduate student majoring in clinical psychology. Michelle exemplifies what it means to be a student at The Ohio State University through her research, her outreach to the community, and for the leadership she has provided on campus.

Michelle is a graduating senior and has accomplished much during her time at Ohio State. One of her many achievements has been her senior honors thesis, working with Dr. Charles Emery, a professor in her department. The subject of her research is the impact of exercise on the psychological well-being and nutritional status among adults with emphysema.

Adding to her academic achievements, Michelle has also made a difference on campus as president of Psi Chi, the national honor society for psychology, and is currently serving as an officer in the senior honorary, Mortar Board. In addition to her campus involvement, Michelle also volunteers working with inmates, at a maximum security prison, who have severe psychological problems.

Michelle will graduate this spring with a 3.94 GPA, and then continue her education at Ohio State in Graduate School where she will be studying clinical psychology with an emphasis in health. Eventually, Michelle hopes to receive her Ph.D. degree in clinical psychology and obtain a position as a teacher/researcher at a major research institution. Hopefully, you can stay at Ohio State!

Michelle, on behalf of the Board of Trustees and President Kirwan, I want to congratulate you on all of your accomplishments and wish you the best as you

STUDENT RECOGNITION AWARD (contd)

Mr. Shultz: (contd)

pursue your education here at Ohio State. Congratulations on receiving the Board of Trustees Student Recognition Award.

Ms. Michelle Kiracofe:

I'd just like to say what an honor it is to be here today, and to have been chosen for this award. I'd also like to emphasize that some of this are things that I do, but the reason I can do these things is because of the type of institution that Ohio State is. There are so many opportunities. I have never had a cold shoulder from a professor when I wanted to explore something and I have found all the resources that I have needed for my research. I'm very happy with Ohio State and it was a very easy decision to continue here in Graduate School. Go Bucks!

Mr. Shultz:

Thank you, once again, Michelle, and also your family and the people you work with for being here today.

Mr. Brennan:

Congratulations, Michelle.

--0--

CONSENT AGENDA

President William E. Kirwan:

We have seven resolutions on the Consent Agenda today and unless there are any objections, I would like to recommend the following resolutions to the Board:

UNIVERSITY HOSPITALS BOARD APPOINTMENTS/REAPPOINTMENTS

Resolution No. 2002-107

Synopsis: Approval of appointments/reappointments of University Hospitals Board members is proposed.

WHEREAS the Board of Trustees on November 30, 1979, approved the establishment of a University Hospitals Board; and

WHEREAS the membership of the Hospitals Board was approved on April 4, 1980, and has been subsequently amended; and

WHEREAS that paragraph (D) of Hospitals Board bylaw 3335-93-01 be waived, to allow for the appointment of a citizen member beyond the stated terms:

NOW THEREFORE

BE IT RESOLVED, That the following individuals be appointed/reappointed as citizen members of the University Hospitals Board for terms ending as indicated:

UNIVERSITY HOSPITALS BOARD APPOINTMENTS/REAPPOINTMENTS (contd)

Richard Murphey, Jr.	April 2003
Peter F. Frenzer	May 2003
John G. Kramer	May 2003
Grayce M. Sills	May 2003
Robert E.H. Rabold	April 2004
Merom Brachman	May 2004
Sara Ross Soter	May 2004

and

BE IT FURTHER RESOLVED, That, in addition, as provided in paragraph (A) of Hospitals Board bylaw 3335-93-01, the chairperson of the integrated faculty practice group, or other senior faculty physician leader, is appointed by the OSU Board of Trustees in consultation with the President of the University; and

BE IT FURTHER RESOLVED, That Douglas A. Rund, as chairperson of the integrated faculty practice group, be appointed to the University Hospitals Board for a term concurrent with the occupancy of that position.

**AMENDMENTS TO THE BYLAWS OF THE MEDICAL STAFF OF THE ARTHUR G. JAMES
CANCER HOSPITAL AND RICHARD J. SOLOVE RESEARCH INSTITUTE**

Resolution No. 2002-108

Synopsis: The amendments to the *Bylaws of the Medical Staff of The Arthur G. James Cancer Hospital and Richard J. Solove Research Institute* are recommended for approval.

WHEREAS The Arthur G. James Cancer Hospital and Richard J. Solove Research Institute Board pursuant to bylaw 3335-109-02 of the James Cancer Hospital Board Bylaws is authorized to recommend to the Board of Trustees the adoption of amendments to the *Bylaws of the Medical Staff of The Arthur G. James Cancer Hospital and Richard J. Solove Research Institute*; and

WHEREAS the proposed amendments to the *Medical Staff Bylaws* were previously endorsed and ratified by The Arthur G. James Cancer Hospital and Richard J. Solove Research Institute Board on March 19, 2002, as follows:

Amended Bylaws of the Medical Staff

3335-111-04 Membership.

(A) Qualifications.

(1) and (2) unchanged.

(3) Board certification.

An applicant for membership shall at the time of appointment or reappointment, be and remain board certified in a medical specialty approved by the American medical association and American board of medical specialties, or other applicable certifying boards for doctors of osteopathy, podiatry, psychology, and dentistry. An applicant who is an active candidate for board certification at the time of initial appointment or reappointment shall have three years from the date eligibility was first attained to become board certified. Board certification is a continuing requirement. Whenever recertification

**AMENDMENTS TO THE BYLAWS OF THE MEDICAL STAFF OF THE ARTHUR G. JAMES
CANCER HOSPITAL AND RICHARD J. SOLOVE RESEARCH INSTITUTE (contd)**

Amended Bylaws of the Medical Staff (contd)

- is required by a subspecialty board approved herein, applicants for appointment or reappointment shall meet the terms of recertification established by their respective subspecialty board or boards. Failure to meet or maintain board certification will result in immediate termination from the medical staff. This requirement may be waived by ~~action~~ vote of the medical staff administrative committee, upon the recommendation of the credentials committee or the director of medical affairs.
- (4) Unchanged.
- (5) Resignation, termination or non-reappointment to the faculty of the Ohio state university shall result in immediate termination of membership on the medical staff of the CHRI for attending, associate attending and clinical attending staff members.
- (5) through (8) unchanged.
- (B) through (D) unchanged.
- (E) Procedure for appointment.
- (1) The completed and signed application for membership on the medical staff shall be presented to the director. Signing the application constitutes a consent to be interviewed in regard to the application, authorizes appropriate personnel within the CHRI to consult with members of the medical staffs of other hospitals with which the applicant has been or has attempted to be associated, and with others who may have information bearing on the applicant's competence, health status, character and ethical qualifications. The applicant also consents to inspection by CHRI personnel of all records and documents that may be material to the evaluation of professional qualifications and competence to carry out the clinical, medical, and educational privileges for which the applicant is applying as well as professional ethical qualifications for medical staff membership and further releases from any liability all representatives of the CHRI for acts performed concerning this process. The applicant has an affirmative duty to disclose any prior or current challenges to licensure, including voluntary and involuntary relinquishment of such licensure, ~~or~~ any loss or limitations of membership in any professional organization, or loss or limitations of medical staff membership or privileges at any other hospital, including voluntary terminations, voluntary or involuntary relinquishment of board certification or DEA certificate, voluntary or involuntary cancellation of professional liability insurance and, at a minimum, final judgments or settlements in malpractice cases. Upon request of the medical staff administrative committee, the applicant will document physical and mental status with sufficient adequacy to demonstrate that any patient treated by the applicant will receive professional care of a generally recognized level of high quality and efficiency. The conditions of this paragraph shall be deemed continuing and may be applicable to issues of continued good standing as a member of the medical staff. Individuals in administrative positions who request medical staff membership or clinical privileges are subject to the same procedures as all other applicants for membership and privileges.
- The application for medical staff membership and/or clinical privileges shall be deemed complete when the following documents and information are received by the director; notice of faculty appointment, (except for community oncologist attending staff and community associate staff), completed and signed application, photograph attached, photostat of license, DEA certificate and board certification (including verification by a primary source), chief of section, chief of clinical division (if applicable) and department chairperson's endorsements, except as otherwise specified in these rules, three letters of recommendation or reference forms, at least one of which references the applicant's current health status, delineation of privileges form including, but not limited to,

**AMENDMENTS TO THE BYLAWS OF THE MEDICAL STAFF OF THE ARTHUR G. JAMES
CANCER HOSPITAL AND RICHARD J. SOLOVE RESEARCH INSTITUTE (contd)**

Amended Bylaws of the Medical Staff (contd)

documentation of training and experience when privileges for laparoscopic procedures and/or use of lasers are requested, and malpractice insurance policy face sheet.

(2) and (3) unchanged.

(4) The medical staff administrative committee (see paragraph (B) of rule 3335-111-10 of the Administrative Code) shall recommend to the director, the appropriate department chairperson, and the chief of the CHRI section that the application be accepted, further investigated, or rejected. The director will forward the candidate's qualifications, with recommendations to ~~the board of trustees of the Ohio state university after approval by the hospitals board~~ The Arthur G. James Cancer Hospital and Richard J. Solove Research Institute Board (hereafter hospital board). Under certain circumstances, the application may be reviewed and approved by a designated subcommittee of the hospital board prior to presentation to the full board. All applications receiving expedited approval shall be submitted to the hospital board for action at its next meeting. Following approval by the hospital board or the designated subcommittee of the hospital board, the candidate is eligible to participate in patient care activities as defined on the approved clinical privilege form. In order for an applicant to be eligible for expedited approval by the subcommittee of the hospital board, the application must contain no significant prior unresolved malpractice actions, no reference problems, few prior hospital affiliations and no reports of disciplinary action, licensure restrictions or any type of competency issue. The expedited process is intended to streamline only the approval process. It does not modify the credentials verification process.

(5) When the ~~hospital board of trustees of the Ohio state university~~ hospital board has acted, the director of medical affairs of the CHRI shall transmit the decision in writing to the applicant. The director of medical affairs shall also notify the chairperson of the appropriate academic department. Recommendations of the hospital board shall be forwarded to the University Board of Trustees for approval.

(F) Procedure for reappointment.

(1) Unchanged.

(2) The basis on which the chairperson of the academic department and the chiefs of the sections of the CHRI are to act in regard to the reappointment of a medical staff member and the clinical privileges to be granted upon such reappointment shall be a member's professional competence; clinical judgment; ethical conduct; current licensure, listing of CME units, fifty percent of which shall relate to the applicant's clinical specialty and are consistent with the licensing requirements of the applicable state professional board and privileges requested; health status, including any reasonable evidence and/or health assessment that may be requested by the credentials committee, the medical staff administrative committee or committee on physician health; annual PPD test; participation in clinical research programs; participation in staff affairs; compliance with the bylaws, rules and regulations of the medical staff including quality assurance responsibilities, and the board of trustees of the Ohio state university; cooperation with CHRI personnel; relations with other physicians, other health professionals or other staff; professional attitude toward patients; clinical and technical skills as indicated in part by the results of monitoring and evaluation activities; adherence to the access and communication standards; and, fulfillment of responsibilities to the university and the public. Continued membership on the medical staff requires participation in the patient care activities of the CHRI. A staff member who fails to admit patients or engage in comparable patient care activities in the CHRI (as determined by the director of medical affairs) for the preceding year will not be reappointed to the medical staff. The candidate

**AMENDMENTS TO THE BYLAWS OF THE MEDICAL STAFF OF THE ARTHUR G. JAMES
CANCER HOSPITAL AND RICHARD J. SOLOVE RESEARCH INSTITUTE (contd)**

Amended Bylaws of the Medical Staff (contd)

may reapply for membership on the medical staff by procedures set forth in this rule subject to the same provisions and probation as new applicants for membership.

(3) through (5) unchanged.

(6) The final action of the medical staff administrative committee regarding a reappointment decision will be communicated by the director, along with the recommendation of the medical director, to the professional affairs committee of the hospital board, and thereafter to the hospital board. The hospital board shall make a final decision and instruct the director to notify the same parties as directed in paragraph (E)(5) of this rule. (B/T 9/1/93, B/T 3/3/95, B/T 4/3/96, B/T 12/6/96, B/T 9/1/99, B/T 12/3/99, B/T 6/2/2000, B/T 4/5/2002)

3335-111-05 Corrective action.

(A) Procedures.

(1) Whenever the activities or professional conduct of a member of the medical staff of the CHRI violate the standards or aims of the medical staff or standards of professional conduct; is considered to be disruptive to the operation of the CHRI; violates the bylaws, rules and regulations of the medical staff, or the board of trustees of the Ohio state university, or the state or federal law, corrective action against such a medical staff member may be initiated by a chief of a CHRI section, chairperson of the appropriate academic department, the director of medical affairs, the director, an officer or member of the medical staff, the dean of the appropriate college, or any member of the hospital board of trustees of the Ohio state university. All requests for corrective action shall be in writing, shall be submitted to the director, and shall be supported by reference to the specific activities or conduct which constitute grounds for the requested action.

Balance unchanged.

3335-111-06 Hearing and appellate review procedure.

(A) through (C) unchanged.

(D) Conduct of hearing.

(1) through (7) unchanged.

(8) Within ~~seven~~ fourteen days after the conclusion of the taking of all evidence and of all hearings, the medical staff administrative committee shall make a written report of its findings and its recommendation and shall forward the same together with the hearings record and all other documentation to the chairperson of the hospital board of trustees ~~by way of the executive committee~~. The decision may recommend confirmation, modification, or rejection of the prior adverse decision and may impose more severe sanctions than were provided in the decision from which this request for hearing was made. The affected member of the medical staff shall be notified of the decision of the executive committee by the director. Notice of that decision shall be sent certified return receipt mail to the affected medical staff member at the member's last known address as determined by university records.

(9) The decision and record of the medical staff administrative committee shall be transmitted to the professional affairs committee of the hospital board, which shall, subject to the affected member's right to appeal and implementation of paragraph (E) of this rule, consider the matter at its next scheduled meeting, or at a special meeting to be

**AMENDMENTS TO THE BYLAWS OF THE MEDICAL STAFF OF THE ARTHUR G. JAMES
CANCER HOSPITAL AND RICHARD J. SOLOVE RESEARCH INSTITUTE (contd)**

Amended Bylaws of the Medical Staff (contd)

held no less than thirty days following receipt of the transmittal. The professional affairs committee may accept, reject, or modify the decision of the medical staff administrative committee.

(10)The recommendation of the professional affairs committee shall be promptly considered by the hospital board at its next scheduled meeting. The hospital board may accept, reject, or modify the recommendation of the professional affairs committee.

(11)A copy of the hospital board decision shall be sent by certified return receipt mail to the affected medical staff member at the member's last known address as determined by university records.

(E) ~~Appeal to the president of the university process.~~

(1) ~~Within fourteen days after receipt of a notice by an affected medical staff member of the action of the medical staff administrative committee the staff member may, by written notice to the president of the Ohio state university chairperson of the hospital board, request an appellate review by the president of the university appeal. Such appellate review appeal shall only be held on the record on which the adverse decision is based, as appended by the medical staff member's statement provided for below before the medical staff administrative committee.~~

(2) ~~If such review an appeal is not requested within said the fourteen-day period, the affected medical staff member shall be deemed to have waived the right to the same an appeal, and to have accepted such adverse decision, and the same shall become effective immediately as provided for in paragraph (B) of this rule.~~

(3) ~~The review shall be conducted by the president of the Ohio state university. The appeal shall be conducted by the professional affairs committee of the hospital board.~~

(4) ~~The affected medical staff member shall have access to the reports and records, including transcripts, if any, of the medical staff administrative committee and all other material, favorable or unfavorable, that have been considered by that committee. The member shall then submit a written factual statement in his/her own behalf in which specifying those factual and procedural matters with which the member disagrees, and the reasons for such disagreement, shall be specified. This written statement may cover any matters raised at any step in the procedure to which the appeal is related, and legal counsel may assist in its preparation. Such written statement shall be submitted to the president of the Ohio state university at least seven days prior to the scheduled date for review professional affairs committee no later than seven days following the date of the affected member's notice of appeal.~~

(5) ~~New or additional matters not raised during the grievance committee hearing or in the medical staff administrative committee hearings shall only be introduced on appeal at the review by the president of the Ohio state university sole discretion of the professional affairs committee.~~

(6) ~~The president of the Ohio state university may affirm, modify, or reject any prior decision, or at the president's discretion Within fourteen days following submission of the written statement by the affected medical staff member, the professional affairs committee shall recommend to the hospital board that the adverse decision be affirmed, modified or rejected, or to refer the matter back to the medical staff administrative committee for further review and recommendation within fourteen days. Such referral to the medical staff administrative committee may include a request for further investigation. The~~

**AMENDMENTS TO THE BYLAWS OF THE MEDICAL STAFF OF THE ARTHUR G. JAMES
CANCER HOSPITAL AND RICHARD J. SOLOVE RESEARCH INSTITUTE (contd)**

Amended Bylaws of the Medical Staff (contd)

~~president's decision shall be mailed certified return receipt to the affected medical staff member at the last known address as determined by university records.~~

(7) Any final decision by the hospital board shall be communicated by the director by certified return receipt mail to the affected medical staff member at the member's last known address as determined by university records. The director shall also notify in writing the senior vice president for health sciences, the dean of the college of medicine and public health, the chief medical officer of OSU health system, the vice president for health services, the director of medical affairs, chief of staff, the section chief, department chair and the person(s) who initiated the request for peer review. The director shall take immediate steps to implement the final decision.

~~(F) Appeal to the board of trustees of the Ohio state university.~~

~~(1) If the affected medical staff member wishes to appeal the final decision of the president of the Ohio state university, the member may within fourteen days after notification of the president's decision request that the record of the proceedings of the medical staff administrative committee's hearing be forwarded to the board of trustees of the Ohio state university. Failure to appeal within fourteen days shall make the president's decision final. The board, in its discretion, may accept, reject, or modify the decision of the president. It may request the record of proceedings of the medical staff administrative committee as well as any information considered by the president in order to take specific action relating to the matter under review.~~

~~(2) The secretary of the board of trustees of the Ohio state university shall notify the medical staff administrative committee and the president of the university of the action taken by the board of trustees of the Ohio state university. Subsequent to this notification, the secretary of the board of trustees of the Ohio state university shall notify the affected medical staff member of the final action taken on the appeal. (B/T 9/1/93, B/T 4/5/2002)~~

3335-111-07 Divisions of the medical staff.

The medical staff of the CHRI shall be divided into honorary, attending, associate attending, clinical, community oncologist attending, community associate, and limited designations. All medical staff members with admitting privileges may admit patients in accordance with state law and criteria for standards of care established by the medical staff.

(A) through (F) unchanged.

(G) Limited medical staff.

(1) Unchanged.

(2) Responsibilities:

The limited staff shall:

(a) through (c) unchanged.

(d) Make regular satisfactory professional progress and satisfy ~~Satisfy~~ the expectations of the program director of the graduate medical education program to which they are appointed.

(H) Unchanged.

**AMENDMENTS TO THE BYLAWS OF THE MEDICAL STAFF OF THE ARTHUR G. JAMES
CANCER HOSPITAL AND RICHARD J. SOLOVE RESEARCH INSTITUTE (contd)**

Amended Bylaws of the Medical Staff (contd)

(I) Clinical privileges.

(1) Unchanged.

(2) Temporary and special privileges:

- (a) Temporary privileges -- with the written request and approval of the chairperson of the department in which the privileges will be exercised and the chief of the CHRI section, the director of medical affairs may act on behalf of the hospital board and grant temporary privileges when an application for full appointment is pending and there are specific patient care needs that mandate an immediate authorization to practice. An appropriately licensed professional may be granted temporary privileges for an initial period of thirty days, with subsequent renewals approved by the director of medical affairs not to exceed the pendency of the application. Such privileges shall be exercised in accordance with the conditions specified in rule 3335-111-04 of the Administrative Code.

Balance unchanged.

3335-111-08 Organization of the CHRI.

(A) and (B) unchanged.

(C) The sections.

Each member of the attending, associate attending, clinical, limited, and honorary staff shall be assigned to a CHRI section by the director upon the recommendation of the department chairperson and the credentials committee.

There are four clinical sections: medical oncology, surgical oncology, radiation oncology and pathology. Appointment to a specific section is based on the clinical specialty of the applicant for medical staff membership. Each section is headed by a section chief who has the responsibility to oversee all research and clinical activities conducted by members of the section. Specifically, the section chief shall be responsible for the following: the development and implementation of policies and procedures that guide and support the provision of service; recommendations re: staffing needs and clinical privileges for all members appointed to the section; the orientation and continuing ~~education~~ surveillance of the professional performance of all section members; recommendation for space and other resources needed. The section chief is appointed by the director.

(D) Department chairs.

Departmental chairpersons are appointed by the dean of the college of medicine and public health and participate in the processing of applications for appointment and reappointment to the medical staff pursuant to these rules, including the development of criteria for granting of clinical privileges, and may also be appointed to serve as delegates at large on the medical staff administrative committee. The chair participates in the evaluation of the professional growth and appropriate humanistic qualities of members of the limited medical staff.

Balance unchanged.

3335-111-09 Elected officers of the medical staff of the CHRI.

(A) through (D) unchanged.

**AMENDMENTS TO THE BYLAWS OF THE MEDICAL STAFF OF THE ARTHUR G. JAMES
CANCER HOSPITAL AND RICHARD J. SOLOVE RESEARCH INSTITUTE (contd)**

Amended Bylaws of the Medical Staff (contd)

(E) Election of officers.

(1) through (5) unchanged.

(6) An officer may be removed from the elected position by a majority vote upon written ballot of the attending and associate attending staff following a regularly scheduled semi-annual meeting. Grounds for removal shall be malfeasance, misfeasance, or nonfeasance in office, as documented by written charges submitted to the chief of staff or to the director of medical affairs if charges are filed against the chief of staff, or if the officer is unwilling or unable to perform the duties as assigned.

(F) and (G) unchanged.

3335-111-10 Administration of the medical staff of the CHRI.

Medical staff committees.

(A) Unchanged.

(B) Medical staff administrative committee:

(1) Composition:

(a) Chief of staff, chief of staff-elect; section chiefs of medical oncology, radiation oncology, surgical oncology and pathology; CHRI chair of clinical quality management policy group; chiefs of CHRI services; CHRI director, CHRI deputy director, CHRI director of administration, CHRI director of medical affairs, CHRI immediate past chief of staff, CHRI associate director for professional education; six at-large delegates, CHRI administrator for nursing; CCC director for clinical research, CCC director for cancer control, senior vice president for health sciences and dean of the college of medicine and public health and university hospitals medical director.

(b) All of the above will have voting privileges, except the CCC directors, the administrator for nursing, the senior vice president for health sciences and dean of the college of medicine and public health, ~~and~~ university hospitals medical director, and the director of administration who will be ex officio non-voting members.

(c) Unchanged.

(2) Duties:

(a) through (k) unchanged.

(l) To oversee functions related to performance improvement of professional services provided by individuals with clinical privileges.

~~(j)~~

(m) To perform other functions as are appropriate.

(3) Unchanged.

**AMENDMENTS TO THE BYLAWS OF THE MEDICAL STAFF OF THE ARTHUR G. JAMES
CANCER HOSPITAL AND RICHARD J. SOLOVE RESEARCH INSTITUTE (contd)**

Amended Bylaws of the Medical Staff (contd)

(C) Credentials committee:

(1) Composition:

The committee shall be composed of the chiefs of the four sections: medical oncology, surgical oncology, radiation oncology and pathology and two additional members of the medical staff or their designee. Appointments to the committee shall be in accordance with paragraph (A) of this rule. The chairperson of the committee shall be appointed by the director of medical affairs, ~~the chief of staff, and the chief of staff-elect.~~

(2) Unchanged.

(D) Unchanged.

(E) Committee for physician health.

(1) Unchanged.

(2) Duties:

(a) To report to the medical staff leadership instances of unsafe treatment.

~~(a)~~(b) To consider issues of physician health or impairment when requested to do so by the physician or another member or committee of the medical staff, hospital staff, or any other individual.

~~(b)~~(c) To provide appropriate internal and external counsel and referral for diagnosis and treatment to enable ~~physician~~ physicians to provide appropriate standards of care.

~~(c)~~(d) To consult regularly with the chief of staff and ~~medical~~ director of medical affairs of the hospital in monitoring the affected physician and the safety of patients until rehabilitation or any disciplinary process is complete.

~~(d)~~(e) To advise credentials and/or other appropriate medical staff committees on any issues affecting the quality of patient care. To evaluate credibility of a complaint, allegation or concern.

~~(e)~~(f) It will be the responsibility of the chairperson of the committee to assure that all proceedings and records are handled and kept with utmost confidentiality.

(g) To educate hospital and medical staffs about illness/impairment recognition issues specific to physicians.

(F) and (G) unchanged.

NOW THEREFORE

BE IT RESOLVED, That the foregoing amendments to the *Bylaws of the Medical Staff of The Arthur G. James Cancer Hospital and Richard J. Solove Research Institute* be adopted as recommended by The Arthur G. James Cancer Hospital and Richard J. Solove Research Institute Board.

RENAMING OF THE DEPARTMENT OF ANATOMY AND MEDICAL EDUCATION

Resolution No. 2002-109

Synopsis: Renaming of the Department of Anatomy and Medical Education to the Department of Biomedical Informatics is proposed.

WHEREAS the proposed name change is consistent with the new and expanded scope, direction, and mission of the program; and

WHEREAS the department envisions the development of research collaborations reflective of the new name; and

WHEREAS there will be no negative impact on existing undergraduate and graduate programs and new courses will be developed on applications of informatics in the medical sciences; and

WHEREAS the proposal has been endorsed by the governance structure of the college, the Council of Chairs, the college's Faculty Council, key units within the health sciences colleges, and the Department of Computer and Information Sciences; and

WHEREAS the proposal adheres to all Office of Academic Affairs Guidelines for a name change of an academic unit; and

WHEREAS the proposal was discussed and approved by the Council on Academic Affairs subcommittee, the full Council on Academic Affairs, and was approved by the University Senate at its March 14, 2002 meeting:

NOW THEREFORE

BE IT RESOLVED, That the Department of Anatomy and Medical Education be renamed the Department of Biomedical Informatics in the College of Medicine and Public Health, effective immediately.

HONORARY DEGREE

Resolution No. 2002-110

Synopsis: The awarding of an honorary degree to Arthur M. Schlesinger, Jr. is recommended for approval.

WHEREAS pursuant to paragraph (B)(4) of rule 3335-1-03 of the Administrative Code, the President, after consultation with the Steering Committee of the University Senate, recommended to the Board of Trustees awarding of an honorary degree as listed below:

Arthur M. Schlesinger, Jr.

Doctor of Humane Letters

NOW THEREFORE

BE IT RESOLVED, That the above honorary degree be awarded in accordance with the recommendation at a time convenient to the University and the recipient.

RESOLUTIONS IN MEMORIAM

Resolution No. 2002-111

Synopsis: Approval of Resolutions in Memoriam is proposed.

RESOLVED, That the Board adopt the following Resolutions in Memoriam and that the President be requested to convey a copy to the families of the deceased.

RESOLUTIONS IN MEMORIAM (contd)

Walter E. Carey

The Board of Trustees of The Ohio State University expresses its sorrow upon the death on February 9, 2002, of Walter E. Carey, Associate Professor Emeritus in the Department of Mechanical Engineering.

Professor Carey held a Bachelor of Science degree in physics from Kenyon College as well as a Master of Science degree in physics and a Ph.D. degree in zoology from The Ohio State University. He devoted his entire teaching career to Ohio State, serving from the time he finished his Ph.D. in 1968 until his retirement in 1994. Professor Carey also served in many administrative capacities. He was director of The Ohio State University Nuclear Reactor Laboratory from 1968 to 1977, associate director of CLEAR/Stone Laboratory at Put-in-Bay from 1974 to 1980, and director of the Office of Radiation Safety from 1983 until his retirement in 1994. Professor Carey specialized in radiation protection, radiation effects on biological systems, and reactor operations. Many of his students are now radiation safety officers, working daily to ensure safe and beneficial uses of radiation and radioactive materials.

Professor Carey was very active in professional organizations and felt a strong sense of responsibility to contribute to society by participating in public policy discussions. He was a certified health physicist and member of the Health Physics Society. He was also a member of the American Nuclear Society and the Ohio Academy of Science. Professor Carey was the immediate past chair of the Governor's Radiation Advisory Council which is housed in the Ohio Department of Health, member of the Governor's Advisory Committee on Low-Level Radioactive Waste, member of the Expert Advisory Panel to the governor of the State of Ohio on Nuclear Power Plant Emergencies, and founding member, member of the board, and past chairman of the board of the Ohio Radioactive Materials Users Group, Inc.

On behalf of the University community, the Board of Trustees expresses to the family of Professor Walter E. Carey its deepest sympathy and sense of understanding of their loss. It was directed that this resolution be inscribed upon the minutes of the Board of Trustees and that a copy be tendered to his family as an expression of the Board's heartfelt sympathy.

Wilbur C. Roberts

The Board of Trustees of The Ohio State University expresses its sorrow upon the death on July 15, 2001, of Wilbur C. "Wib" Roberts, Assistant Professor Emeritus in the Ohio State University Extension.

Professor Roberts was born October 13, 1913, in Dulin, West Virginia. He received a Bachelor of Science degree in agriculture from West Virginia University in 1939.

Wib began his Extension career in Ohio in October 1954 as the associate county agent in Columbiana County. In January 1957 he became the agricultural agent in Stark County. He held this appointment until his retirement in December 1973.

During Professor Roberts' career with Extension he was Stark County chair and served on local committees. Under his leadership, Stark County was chosen to receive the Environmental Improvement Award given by the Timken Roller Bearing Company. He also was instrumental in leading lawn and garden seminars in the local community. He was a member of the National Association of County Agricultural Agents and participated in both state and national meetings.

These contributions in providing excellent Extension educational programs during his career earned him the respect and admiration of coworkers and associates throughout the state.

RESOLUTIONS IN MEMORIAM (contd)

Wilbur C. Roberts (contd)

On behalf of the University community, the Board of Trustees expresses to the family of Wilbur C. Roberts its deepest sympathy and sense of understanding of their loss. It was directed that this resolution be inscribed upon the minutes of the Board of Trustees and that a copy be tendered to his family as an expression of the Board's heartfelt sympathy.

REPORT OF RESEARCH CONTRACTS AND GRANTS

Resolution No. 2002-112

Synopsis: The reports on research and other sponsored program contracts and grants and the summary for February 2002 are presented for Board acceptance.

WHEREAS monies are solicited and received on behalf of the University from governmental, industrial, and other agencies in support of research, instructional activities, and service; and

WHEREAS such monies are received through The Ohio State University Research Foundation:

NOW THEREFORE

BE IT RESOLVED, That the research agreement between The Ohio State University and The Ohio State University Research Foundation for the contracts and grants reported herein during the month of February 2002 be approved.

REPORT ON UNIVERSITY DEVELOPMENT

Resolution No. 2002-113

Synopsis: The report on the receipt of gifts and the summary for February 2002 are presented for Board acceptance.

WHEREAS monies are solicited and received on behalf of the University from alumni, industry, and various individuals in support of research, instructional activities, and service; and

WHEREAS such gifts are received through The Ohio State University Development Fund and The Ohio State University Foundation; and

WHEREAS this report includes the establishment of thirteen (13) new named endowed funds and the amendment of five (5) named endowed fund:

NOW THEREFORE

BE IT RESOLVED, That the acceptance of the report from The Ohio State University Development Fund and The Ohio State University Foundation during the month of February 2002 be approved.

REPORT ON UNIVERSITY DEVELOPMENT (contd)

TOTAL UNIVERSITY PRIVATE SUPPORT

July through February
2000-2001 Compared to 2001-2002

GIFT RECEIPTS BY DONOR TYPE

	Dollars July through February		
	<u>2000-2001</u>	<u>2001-2002</u>	<u>%Change</u>
Individuals:			
Alumni (Current Giving)	\$24,042,701	\$25,023,745	4
Alumni (From Bequests)	<u>5,451,535</u>	<u>3,910,598</u>	(28)
Alumni Total	\$29,494,236	\$28,934,343	(2)
Non-Alumni (Current Giving)	\$18,496,684	\$11,191,493	(39)
Non-Alumni (From Bequests)	<u>9,563,277</u>	<u>2,791,735</u>	(71)
Non-Alumni Total	\$28,059,961	\$13,983,228	(50)
Individual Total	\$57,554,197	\$42,917,571	(25) ^A
Corporations/Corp/Foundations	\$26,871,270	\$27,567,070	3
Private Foundations	\$11,443,225	\$14,766,787	29 ^B
Associations and Other Organizations	<u>\$2,874,406</u>	<u>\$3,065,428</u>	<u>7</u>
Total	\$98,743,098	\$88,316,856	(11)

NOTES

- A Overall individual giving is down 26% in that gifts at the \$10,000 or more level are down 24% (\$43.9 million from 444 gifts last year compared with \$28.6 million from 360 gifts this year.)
- B Foundation giving at the \$10,000 or more level is up for the first eight months of the fiscal year (\$10.7 million from 141 gifts last year; \$14.1 million from 152 gifts this year).

REPORT ON UNIVERSITY DEVELOPMENT (contd)

TOTAL UNIVERSITY PRIVATE SUPPORT (contd)

July from February
2000-2001 Compared to 2001-2002

GIFT RECEIPTS BY PURPOSE

	Dollars July through February		
	<u>2000-2001</u>	<u>2001-2002</u>	<u>% Change</u>
Gift Receipts to Current Use and Endowment Funds:			
Buildings/Equipment	\$11,358,598	\$15,779,918	39
Faculty Support	\$9,662,629	\$9,854,204	2
Program Support	\$60,745,923	\$46,536,490	(23)
Student Financial Aid	\$9,269,786	\$9,553,750	3
Annual Funds-Colleges/Departments	\$6,612,284	\$5,745,894	(13)
Annual Funds-University	<u>\$1,093,878</u>	<u>\$846,600</u>	(23)
Total	\$98,743,098	\$88,316,856	(11)

GIFT ADDITIONS TO ENDOWMENT

Dollars
July through February

<u>2000-2001</u>	<u>2001-2002</u>	<u>% Change</u>
\$27,175,737	\$27,910,885	3%

REPORT ON UNIVERSITY DEVELOPMENT (contd)

THE OHIO STATE UNIVERSITY DEVELOPMENT FUND

	<u>Previous Gifts</u>	<u>Current Gifts</u>	<u>Total Gifts</u>
<u>Establishment of Named Endowed Fund</u>			
Irma Cooper Endowment Fund for International Studies in Music (Used to support international activities for students in the School of Music; provided by gifts from Irma Cooper, Professor Emeritus)		\$35,000.00	\$35,000.00

Change in Description of Named Endowed Fund

The Verland W. and Brian Belt Engineering Scholarship Fund

Change in Name and Description of Named Endowed Fund

From: The Young Bucks of Central Ohio Alumni Scholarship Fund
To: The Young Buckeyes of Central Ohio Alumni Scholarship Fund

THE OHIO STATE UNIVERSITY FOUNDATION

	<u>Previous Gifts</u>	<u>Current Gifts</u>	<u>Total Gifts</u>
<u>Establishment of Named Endowed Funds</u>			
The Richard S. Zimmerman Athletic Scholarship Fund (Used to supplement scholarships costs of a student athlete on the football team; provided by gifts from Richard S. Zimmerman)		\$120,261.00	\$120,261.00
The International Camelid Initiative Fund (Used to support the camelid initiative in the College of Veterinary Medicine; provided by gifts from camelid owners, breeders, veterinarians, and friends of the college)		\$113,512.30	\$113,512.30
The Fountain C. Beattie, M.D. and Mary Beattie Medical Scholarship Fund (Used to provide scholarship(s) in the College of Medicine and Public Health; provided by gifts from the Fountain C. and Mary Beattie Trust)		\$50,000.00	\$50,000.00
The Dr. Martin H. Zarnett Equine Scholarship Fund (Used to support a student in the College of Veterinary Medicine; provided by gifts from family and friends in memory of Martin Zarnett)		\$43,737.36	\$43,737.36
The National City Bank Dean's Innovation Fund (Used to support new initiatives in the Fisher College of Business by faculty and students; provided by a gift from the National City Bank)		\$40,000.00	\$40,000.00

REPORT ON UNIVERSITY DEVELOPMENT (contd)

THE OHIO STATE UNIVERSITY FOUNDATION (contd)

	<u>Previous Gifts</u>	<u>Current Gifts</u>	<u>Total Gifts</u>
<u>Establishment of Named Endowed Funds (contd)</u>			
The Paul E. Young, Jr. 1955 Scholarship Fund (Used to provide support for students in the Knowlton School of Architecture; provided by a gift from Professor Paul E. Young Jr.'s family)		\$29,750.00	\$29,750.00
The Stanley E. and Nancy L. Longbrake Fund in The Max M. Fisher College of Business (Used to provide a scholarship in the Fisher College of Business; provided by gifts from Stanley E. Longbrake and Nancy L. Longbrake)		\$28,148.00	\$28,148.00
Clinton County 4-H Endowment Fund (Used to support the Clinton County 4-H program; provided by gifts from friends of Clinton County 4-H)		\$27,690.00	\$27,690.00
The Linda K. Pulskamp Fund in Neuromuscular Research (Used to support neuromuscular research in the College of Medicine and Public Health; provided by gifts from Frank E. Pulskamp, DDS, and Linda K. Pulskamp.)		\$27,521.13	\$27,521.13
The Linda Weber Daniel Athletic Training Scholarship Fund (Used to supplement tuition costs of student in the Athletic Training Program; provided by gifts from family, friends, alumni, and professional colleagues in memory of Linda Weber Daniel)		\$25,395.00	\$25,395.00
The James T. Mahoney and Jean Casey Mahoney Scholarship Fund (Used to provide scholarships in the College of Education; provided by gifts from Jean Casey Mahoney and James T. Mahoney)		\$25,001.00	\$25,001.00
The Connelly and Jackson Scholarship Fund (Used to fund scholarships for students in the Moritz College of Law; provided by gifts from William M. Connelly and Reginald S. Jackson, Jr.)		\$25,000.00	\$25,000.00
<u>Change in Description of Named Endowed Fund</u>			
The Adivar Fellowship Fund For Study of Ottoman and Turkish History			

REPORT ON UNIVERSITY DEVELOPMENT (contd)

THE OHIO STATE UNIVERSITY FOUNDATION (contd)

Change in Name of Named Endowed Fund

From: The Dr. Lee E. Watkins Vice President's
Excellence Endowment Fund
To: The Dr. Lee E. and Rita M. Watkins Vice President's
Excellence Endowment Fund

Change in Name and Description of Named Endowed Fund

From: William M. and Rosalind W. Wolfson Scholarship
in the Fisher College of Business
To: William M. and Rosalind W. Wolfson Scholarship
Fund in the Fisher College of Business

Total	\$591,015.79	\$591,015.79
-------	--------------	--------------

THE OHIO STATE UNIVERSITY DEVELOPMENT FUND

Establishment of Named Endowed Fund

Irma Cooper Endowment Fund for International Studies in Music

The Irma Cooper Endowment Fund for International Studies in Music was established April 5, 2002, by the Board of Trustees of The Ohio State University with gifts from Irma Cooper, Professor Emeritus in the School of Music, Columbus, Ohio.

All gifts are to be invested in the University's Permanent Endowment Fund, under the rules and regulations adopted by the Board of Trustees of The Ohio State University, with the right to invest and reinvest as occasion dictates.

The annual income shall be used to support international activities for students in the School of Music. Funds will be awarded by the director of the School of Music with preference given to students majoring in voice or piano performance.

In the event there are undistributed funds in any given year, the unused income shall be returned to the principal.

It is the desire of the donor that this fund should benefit the University in perpetuity. If the need for this fund should cease to exist or so diminish as to provide unused income, then another use shall be designated by the Board of Trustees as recommended by the director of the School of Music in order to carry out the desire of the donor.

\$35,000.00

Change in Description of Named Endowed Fund

The Verland W. and Brian Belt Engineering Scholarship Fund

The Verland W. and Brian Belt Engineering Scholarship Fund was established March 1, 2002, by the Board of Trustees of The Ohio State University with gifts from Verland W. Belt (B.C.E. 1937) and his son Brian Belt (B.I.E. 1968, M.S. 1969). The description was revised on April 5, 2002.

All gifts are to be invested in the University's Permanent Endowment Fund, under the rules and regulations adopted by the Board of Trustees of The Ohio State University, with the right to invest and reinvest as occasion dictates.

REPORT ON UNIVERSITY DEVELOPMENT (contd)

THE OHIO STATE UNIVERSITY DEVELOPMENT FUND (contd)

Change in Description of Named Endowed Fund (contd)

The Verland W. and Brian Belt Engineering Scholarship Fund (contd)

The annual income shall provide one or more merit scholarships to students majoring in engineering. Selection will be made by the dean of the College of Engineering in consultation with the University Committee on Student Financial Aid.

It is the desire of the donors that this fund should benefit the University in perpetuity. If the need for this fund should cease to exist or so diminish as to provide unused income, then another use shall be designated by the Board of Trustees in consultation with the appropriate college dean, department chairperson, or program administrative officer in order to carry out the desire of the donors.

Change in Name and Description of Named Endowed Fund

The Young Buckeyes of Central Ohio Alumni Scholarship Fund

The Young Bucks of Central Ohio Alumni Scholarship Fund was established December 3, 1999, by the Board of Trustees of The Ohio State University with a gift to The Ohio State University Development Fund from the members and supporters of the Young Buckeyes of Central Ohio Club. The name and description were revised on April 5, 2002.

All gifts are to be invested in the University's Permanent Endowment Fund, under the rules and regulations adopted by the Board of Trustees of The Ohio State University, with the right to invest and reinvest as occasion dictates.

The annual income shall be used to provide scholarships for financially needy students from Franklin County and contiguous counties who will be freshmen entering Ohio State's main campus. The Young Buckeyes of Central Ohio Club will recommend scholarship recipients. The University Committee on Student Financial Aid will make final selection of the scholarship recipients.

It is the desire of the donors that this fund should benefit the University in perpetuity. If the need for this fund should cease to exist or so diminish as to provide unused income, then another use shall be designated by the Board of Trustees in consultation the director of Financial Aid in order to carry out the desire of the donors.

THE OHIO STATE UNIVERSITY FOUNDATION

Establishment of Named Endowed Funds

The Richard S. Zimmerman Athletic Scholarship Fund

The Richard S. Zimmerman Athletic Scholarship Fund was established April 5, 2002, in accordance with the guidelines approved by the Board of Directors of The Ohio State University Foundation, with gifts from Richard S. Zimmerman (B.S.Bus.Adm. 1946) of Columbus, Ohio.

All gifts are to be invested by the Foundation, under the rules and regulations adopted by the Foundation's Board of Directors, with the right to invest and reinvest as occasion dictates.

The annual income shall be used to supplement the student-athlete grant-in-aid scholarship costs of a student athlete who is a member of the football team at the defensive lineman position pursuing an undergraduate degree at The Ohio State University. The director of Athletics will select the recipient in consultation with the University Committee on Student Financial Aid.

REPORT ON UNIVERSITY DEVELOPMENT (contd)

THE OHIO STATE UNIVERSITY FOUNDATION (contd)

Establishment of Named Endowed Funds (contd)

The Richard S. Zimmerman Athletic Scholarship Fund (contd)

It is the desire of the donor that this fund should benefit the University in perpetuity. If the need for this fund should cease to exist or so diminish as to provide unused income, then another use shall be designated by the Foundation Board as recommended by the director of Athletics in order to carry out the desire of the donor.

\$120,261.00

The International Camelid Initiative Fund

The International Camelid Initiative Fund was established April 5, 2002, in accordance with the guidelines approved by the Board of Directors of The Ohio State University Foundation, with gifts from camelid owners, breeders, veterinarians, and friends of the college.

All gifts are to be invested by the Foundation, under the rules and regulations adopted by the Foundation's Board of Directors, with the right to invest and reinvest as occasion dictates.

The annual income shall be used to support the activities of the camelid initiative by providing education and research to enhance and advance the well-being of camelids and the camelid industry throughout the world. The dean of the College of Veterinary Medicine will oversee the use of the funds in consultation with the director of the International Camelid Initiative.

It is the desire of the donors that this fund should benefit the University in perpetuity. If the need for this fund should cease to exist or so diminish as to provide unused income, then another use shall be designated by the Foundation Board as recommended by the dean of the College of Veterinary Medicine to carry out the desire of the donors.

\$113,512.30

The Fountain C. Beattie, M.D. and Mary Beattie Medical Scholarship Fund

The Fountain C. Beattie, M.D. and Mary Beattie Medical Scholarship Fund was established April 5, 2002, in accordance with the guidelines approved by the Board of Directors of The Ohio State University Foundation, with gifts from the Fountain C. and Mary Beattie Trust and made in their memory, that of Dr. Fountain C. Beattie (B.A. 1939, M.D. 1942) and Mary Matheny Beattie (Cert. of Grad. Nurs. 1941) of Palm Coast, Florida.

All gifts are to be invested by the Foundation, under the rules and regulations adopted by the Foundation's Board of Directors, with the right to invest and reinvest as occasion dictates.

The annual income shall be used to provide one or more scholarships to students enrolled in the College of Medicine and Public Health. The selection of the recipient(s) shall be based on financial need and shall be made at the recommendation of the senior vice president for Health Sciences and dean of the College of Medicine and Public Health in consultation with the College of Medicine and Public Health Committee for Scholarship Awards and with the University Committee on Student Financial Aid.

REPORT ON UNIVERSITY DEVELOPMENT (contd)

THE OHIO STATE UNIVERSITY FOUNDATION (contd)

Establishment of Named Endowed Funds (contd)

The Fountain C. Beattie, M.D. and Mary Beattie Medical Scholarship Fund (contd)

It is the desire of the donors that this fund should benefit the University in perpetuity. If the need for this fund should cease to exist or so diminish as to provide unused income, then another use shall be designated by the Foundation Board in consultation with the senior vice president for Health Sciences and dean of the College of Medicine and Public Health in order to carry out the desire of the donors.

\$50,000.00

The Dr. Martin H. Zarnett Equine Scholarship Fund

The Dr. Martin H. Zarnett Equine Scholarship Fund was established April 5, 2002, in accordance with the guidelines approved by the Board of Directors of The Ohio State University Foundation, with gifts from family and friends in memory of Martin Zarnett (B.S. 1963, D.V.M. 1967).

All gifts are to be invested by the Foundation, under the rules and regulations adopted by the Foundation's Board of Directors, with the right to invest and reinvest as occasion dictates.

The annual income shall be used to support one (1) third- or fourth-year student per year who is planning to practice equine medicine. Recipients will be selected by the dean of the College of Veterinary Medicine in consultation with the associate dean for Student Affairs and the University Committee on Student Financial Aid.

It is the desire of the donors that this fund should benefit the University in perpetuity. If the need for this fund should cease to exist or so diminish as to provide unused income, then another use shall be designated by the Foundation Board as recommended by the dean of the College of Veterinary Medicine to carry out the desire of the donors.

\$43,737.36

The National City Bank Dean's Innovation Fund

The National City Bank Dean's Innovation Fund was established April 5, 2002, in accordance with the guidelines approved by the Board of Directors of The Ohio State University Foundation, with a gift from the National City Bank.

All gifts are to be invested by the Foundation, under the rules and regulations adopted by the Foundation's Board of Directors, with the right to invest and reinvest as occasion dictates.

The annual income shall be used to support new initiatives in The Max M. Fisher College of Business by faculty and students as determined by the dean. Initiatives could include technology innovation and instruction, executive education projects, and M.B.A. fellowships with a potential internship with the National City Bank.

It is the desire of the donor that this fund should benefit the University in perpetuity. If the need for this fund should cease to exist or so diminish as to provide unused income, then another use shall be designated by the Foundation Board as recommended by the dean of the Fisher College of Business, in consultation with the National City Bank, in order to carry out the desire of the donor.

\$40,000.00

REPORT ON UNIVERSITY DEVELOPMENT (contd)

THE OHIO STATE UNIVERSITY FOUNDATION (contd)

Establishment of Named Endowed Funds (contd)

The Paul E. Young, Jr. 1955 Scholarship Fund

The Paul E. Young, Jr. 1955 Scholarship Fund was established April 5, 2002, in accordance with the guidelines approved by the Board of Directors of The Ohio State University Foundation, with a gift from Professor Paul E. Young, Jr.'s (B.Arch. 1955, cum laude) family to honor his 33-year teaching career in the School of Architecture.

All gifts are to be invested by the Foundation, under the rules and regulations adopted by the Foundation's Board of Directors, with the right to invest and reinvest as occasion dictates.

The annual income shall be used to provide support for architecture students who, in the judgment of the faculty, consistently exhibit a deep understanding of, and strong commitment to, the role that architecture plays in enhancing the quality of everyday life. The scholarship will be awarded in consultation with the University Committee on Student Financial Aid.

It is the desire of the donors that this fund should benefit the University in perpetuity. If the need for this fund should cease to exist or so diminish as to provide unused income, then another use shall be designated by the Foundation Board in consultation with the director of The Austin E. Knowlton School of Architecture in order to carry out the desire of the donors.

\$29,750.00

The Stanley E. and Nancy L. Longbrake Scholarship Fund
in The Max M. Fisher College of Business

The Stanley E. and Nancy L. Longbrake Scholarship Fund in The Max M. Fisher College of Business was established April 5, 2002, in accordance with the guidelines approved by the Board of Directors of The Ohio State University Foundation, with gifts from Stanley E. Longbrake (B.S.Bus.Adm. 1955) and Nancy L. Longbrake.

All gifts are to be invested by the Foundation, under the rules and regulations adopted by the Foundation's Board of Directors, with the right to invest and reinvest as occasion dictates.

The annual income shall be used for a scholarship for an undergraduate student majoring in business. The student shall have a minimum GPA of 3.0 and shall be a United States citizen. The scholarship will be awarded in consultation with the University Committee on Student Financial Aid.

It is the desire of the donors that this fund should benefit the University in perpetuity. If the need for this fund should cease to exist or so diminish as to provide unused income, then another use shall be designated by the Foundation Board in consultation with the appropriate college dean, department chairperson, or program administrative officer in order to carry out the desire of the donors.

\$28,148.00

Clinton County 4-H Endowment Fund

The Clinton County 4-H Endowment Fund was established April 5, 2002, in accordance with the guidelines approved by the Board of Directors of The Ohio State University Foundation, through current and future gifts from friends of Clinton County 4-H.

REPORT ON UNIVERSITY DEVELOPMENT (contd)

THE OHIO STATE UNIVERSITY FOUNDATION (contd)

Establishment of Named Endowed Funds (contd)

Clinton County 4-H Endowment Fund (contd)

All gifts are to be invested by the Foundation, under the rules and regulations adopted by the Foundation's Board of Directors, with the right to invest and reinvest as occasion dictates.

The annual income from this fund shall be used to support the Clinton County 4-H program. The support may include but is not limited to the funding of scholarships and awards for 4-H members, volunteer leaders, and friends of 4-H; sponsoring seminars and programs; and purchasing material and services that will supplement 4-H programming or increase the visibility and public support of 4-H in Clinton County. All expenditures from this fund shall be approved by the Clinton County 4-H Endowment Committee. Scholarships will be awarded in consultation with the University Committee on Student Financial Aid.

If the need for this fund should cease to exist or so diminish as to provide unused income, then another use shall be designated by the Foundation Board in consultation with the director for the Ohio State University Extension and the committee representing the local 4-H donors.

\$27,690.00

The Linda K. Pulskamp Fund in Neuromuscular Research

The Linda K. Pulskamp Fund in Neuromuscular Research was established April 5, 2002, in accordance with the guidelines approved by the Board of Directors of The Ohio State University Foundation, with gifts from Frank E. Pulskamp, D.D.S., (B.A. 1968, D.D.S. 1971) and Linda K. Pulskamp (B.S. 1969) of Ostrander, Ohio.

All gifts are to be invested by the Foundation, under the rules and regulations adopted by the Foundation's Board of Directors, with the right to invest and reinvest as occasion dictates.

The annual income shall be used to support the advancement of medical knowledge in the field of neuromuscular disease, including basic, clinical, and applied research, as recommended by the chairperson of the Department of Neurology in consultation with the senior vice president for Health Sciences and dean of the College of Medicine and Public Health. The income may support, but is not limited to, scientific supplies, equipment, salaries for research personnel, and activities required for quality medical research.

It is the desire of the donors that this fund should benefit the University in perpetuity. If the need for this fund should cease to exist or so diminish as to provide unused income, then another use shall be designated by the Foundation Board in consultation with the chairperson of the Department of Neurology and with the senior vice president for Health Sciences and dean of the College of Medicine and Public Health in order to carry out the desire of the donors.

\$27,521.13

The Linda Weber Daniel Athletic Training Scholarship Fund

The Linda Weber Daniel Athletic Training Scholarship Fund was established April 5, 2002, in accordance with the guidelines approved by the Board of Directors of The Ohio State University Foundation, with gifts from family, friends, alumni, and professional colleagues in memory of Linda Weber Daniel (B.S. All'd.Hlth.Prof. 1974, M.S. 1983) of Worthington, Ohio.

All gifts are to be invested by the Foundation, under the rules and regulations adopted by the Foundation's Board of Directors, with the right to invest and reinvest as occasion dictates.

REPORT ON UNIVERSITY DEVELOPMENT (contd)

THE OHIO STATE UNIVERSITY FOUNDATION (contd)

Establishment of Named Endowed Funds (contd)

The Linda Weber Daniel Athletic Training Scholarship Fund (contd)

The annual income shall be used to supplement tuition costs of student athletic trainers enrolled in the Athletic Training Program pursuing an undergraduate degree at The Ohio State University. The recipient shall be selected by the director of Athletics in consultation with the director of Athletic Training and the University Committee on Student Financial Aid.

It is the desire of the donors that this fund should benefit the University in perpetuity. If the need for this fund should cease to exist or so diminish as to provide unused income, then another use shall be designated by the Foundation Board as recommended by the director of Athletics in order to carry out the desire of the donors.

\$25,395.00

The James T. Mahoney and Jean Casey Mahoney Scholarship Fund

The James T. Mahoney and Jean Casey Mahoney Scholarship Fund was established April 5, 2002, in accordance with the guidelines approved by the Board of Directors of The Ohio State University Foundation, with gifts from Jean Casey Mahoney (B.S.Ed. 1942, with distinction; M.A. 1956) and James T. Mahoney (B.S.Ed. 1952) (M.S. 1955 – University of Illinois).

Both James and Jean Mahoney spent most of their careers with the Columbus Public Schools, and this endowment reflects their deep and abiding commitment to education. Mr. Mahoney taught mathematics at South High School and Independence High School where he was the computer coordinator. He also taught mathematics and coached basketball at Sherwood Junior High School. Mrs. Mahoney, a social studies and English teacher, was a counselor at Eastmoor High School for 25 years.

All gifts are to be invested by the Foundation, under the rules and regulations adopted by the Foundation's Board of Directors, with the right to invest and reinvest as occasion dictates.

The annual income shall be used for scholarships in the College of Education to benefit equally students seeking teaching certification/licensure in mathematics education and students in counselor education. Students shall have a demonstrated financial need. The dean of the College of Education or designee shall select the scholarship recipients in consultation with the University Committee on Student Financial Aid.

It is the desire of the donors that this fund should benefit the University in perpetuity. If the need for this fund should cease to exist or so diminish as to provide unused income, then another use shall be designated by the Foundation Board in consultation with the dean of the College of Education in order to carry out the desire of the donors.

\$25,001.00

The Connelly and Jackson Scholarship Fund

The Connelly and Jackson Scholarship Fund was established April 5, 2002, in accordance with the guidelines approved by the Board of Directors of The Ohio State University Foundation, with gifts from William M. Connelly (J.D. 1964), Toledo, Ohio, and Reginald S. Jackson, Jr. (B.A. 1968, J.D. 1971), Maumee, Ohio.

REPORT ON UNIVERSITY DEVELOPMENT (contd)

THE OHIO STATE UNIVERSITY FOUNDATION (contd)

Establishment of Named Endowed Funds (contd)

The Connelly and Jackson Scholarship Fund (contd)

All gifts are to be invested by the Foundation, under the rules and regulations adopted by the Foundation's Board of Directors, with the right to invest and reinvest as occasion dictates.

The annual income shall be used to fund scholarships for students in The Michael E. Moritz College of Law, with a preference for students from Northwest Ohio who demonstrate financial need. Selection shall be made by the Moritz College of Law with formal approval by the dean of the Moritz College of Law in consultation with the University Committee on Student Financial Aid.

It is the desire of the donors that this fund should benefit the University in perpetuity. If the need for this fund should cease to exist or so diminish as to provide unused income, then another use shall be designated by the Foundation Board as recommended by the dean of the Moritz College of Law in order to carry out the desire of the donors.

\$25,000.00

Change in Description of Named Endowed Fund

The Adivar Fellowship Fund for Study of Ottoman and Turkish History

The Adivar Fellowship Fund for Study of Ottoman and Turkish History was established November 2, 2001, in accordance with the guidelines approved by the Board of Directors of The Ohio State University Foundation, with gifts from an anonymous donor. The description was revised on April 5, 2002.

All gifts are to be invested by the Foundation, under the rules and regulations adopted by the Foundation's Board of Directors, with the right to invest and reinvest as occasion dictates.

The purpose of this endowment is to strengthen and perpetuate the study of Ottoman and Turkish history, a field taught and studied at this University since the 1930s, and to enhance the national and international competitiveness and distinction of the University in this field. The donor intends more specifically to endow a graduate fellowship in Ottoman and Turkish studies. The annual income shall be used first and foremost to provide a fellowship to recruit or retain a graduate student in Ottoman and Turkish history. Secondly, in cases of exceptional merit, the fellowship may be used to fund overseas dissertation research for a student excluded from, or disadvantaged in, competition for non-departmental research fellowships by reason of nationality or other factors extraneous to the student's merit and that of his or her dissertation research. Graduate students of any nationality are eligible to receive this fellowship. The awarding of this fellowship will be determined by the chairperson of the Department of History in consultation with the department's senior faculty in Ottoman and Turkish studies and the University Committee on Student Financial Aid.

This fellowship will be awarded for one year at a time to a graduate student who has been accepted into the graduate program of the Department of History and approved for funding (stipend and fee authorization) in that program. The fellowship will provide the recipient's stipend during the year or years of their tenure of the fellowship, enabling them to devote full time to their studies.

The purpose of this endowment being to provide support in perpetuity for the study of Ottoman and Turkish history, the donor intends that if the fund grows or if he can increase its principal sufficiently over time, the form in which the fund supports the field may be revised, up to and including the creation of an endowed professorship in this field, and that during his lifetime any

REPORT ON UNIVERSITY DEVELOPMENT (contd)

THE OHIO STATE UNIVERSITY FOUNDATION (contd)

Change in Description of Named Endowed Fund (contd)

The Adivar Fellowship Fund for Study of Ottoman and Turkish History (contd)

such revision will be made at his initiative or with his consent. Alternatively, if the fund declines to the point that it cannot support a full graduate fellowship, it is the intention of the donor that the income from this fund should be used to provide research support funding for graduate students in this field, to purchase books in the field for the library or, lastly, to support the field in other ways, and that the need for the fund shall not be deemed to have ceased to exist until it becomes impossible to use the income of the fund for any of these purposes.

If in any year there is no qualified candidate for the fellowship or the income is not fully used for any reason, any such unused income will be reinvested to principal.

The fellowship will be known for the time being as "The Adivar Fellowship." The donor reserves the right to rename the fellowship permanently at a later date.

It is the desire of the donor that this fund should benefit the University in perpetuity. If the need for this fund should cease to exist or so diminish as to provide unused income, then another use shall be designated by the Foundation Board as recommended by the dean of the College of Humanities in order to carry out the desire of the donor.

Change in Name of Named Endowed Fund

The Dr. Lee E. and Rita M. Watkins Vice President's Excellence Endowment Fund

The Dr. Lee E. Watkins Vice President's Excellence Endowment Fund was established December 6, 2001, in accordance with the guidelines approved by the Board of Directors of The Ohio State University Foundation, with gifts from Dr. Lee E. Watkins (B.S.Agr. 1967, M.S. 1969, Ph.D. 1974) and his wife, Rita M. Watkins of New Palastine, Indiana. Matching gifts were made by Eli Lilly. The name was revised on April 5, 2002.

All gifts are to be invested by the Foundation, under the rules and regulations adopted by the Foundation's Board of Directors, with the right to invest and reinvest as occasion dictates.

The annual income shall be used to support programs identified by the vice president for Agricultural Administration and University Outreach, and executive dean for Food, Agricultural, and Environmental Sciences as current and critical priorities in the College of Food, Agricultural, and Environmental Sciences. Uses of the fund shall include, but not to be limited to support of a positive, creative work environment for students, faculty and staff, "outreach" to our external audiences, encouragement and promotion of student organizations, scholarships, professional development, college promotion and advancement, and other emerging college priorities.

The use of the annual income shall be directed by the vice president for Agricultural Administration and University Outreach, and executive dean for Food, Agricultural, and Environmental Sciences or their designee.

It is the desire of the donors that this fund should benefit the University in perpetuity. If the need for this fund should cease to exist or so diminish as to provide unused income, then another use shall be designated by the Foundation Board in consultation with the vice president for Agricultural Administration and University Outreach, and executive dean for Food, Agricultural, and Environmental Sciences, or their successor, in order to carry out the desire of the donors.

REPORT ON UNIVERSITY DEVELOPMENT (contd)

THE OHIO STATE UNIVERSITY FOUNDATION (contd)

Change in Name and Description of Named Endowed Fund

William M. and Rosalind W. Wolfson Scholarship Fund
in the Fisher College of Business

The William M. and Rosalind W. Wolfson Scholarship in the Fisher College of Business was established September 5, 1997, in accordance with the guidelines approved by the Board of Directors of The Ohio State University Foundation, with gifts designated for support of The Max M. Fisher College of Business from contributions from Rosalind W. and William M. Wolfson (B.S.Bus.Adm. 1948) of Carmel, New York. The name and description were revised on April 5, 2002.

All gifts are to be invested by the Foundation, under the rules and regulations adopted by the Foundation's Board of Directors, with the right to invest and reinvest as occasion dictates.

The annual income shall be used to provide scholarships for economically disadvantaged undergraduate students majoring in business with a minimum of a 3.0 GPA. Preference shall be given to students who graduated from high schools outside of the State of Ohio. Selection of the recipients shall be made by the dean of the Fisher College of Business with recommendations made by the Fisher College of Business academic director of the undergraduate program and in consultation with the University Committee on Student Financial Aid.

It is the desire of the donors that this fund should benefit the University in perpetuity. If the need for this fund should cease to exist or so diminish as to provide unused income, then another use shall be designated by the Foundation Board in consultation with the appropriate college dean, department chairperson, or program administrative officer in order to carry out the desire of the donors.

Upon motion of Ms. Hendricks, seconded by Mr. Patterson, the Board of Trustees adopted the foregoing resolutions by unanimous roll call vote, cast by Messrs. Brennan, Patterson, Sofia, McFerson, and Judge Duncan, Mses. Longaberger, Hendricks, and Davidson.

--0--

ANNUAL COMPENSATION BENCHMARKS REPORT

Provost Edward J. Ray: [Overhead Presentation]

I'd like to call on Vice Provost Barbara Snyder to begin the presentation.

Vice Provost Barbara R. Snyder:

We're here today to give you the Annual Compensation Benchmarks Report to show you how we compare to our benchmark peers and why, as President Kirwan mentioned already, the compensation initiative is so very important to the future of The Ohio State University. I'll be talking first about faculty salaries, and then J Henderson, director of Compensation, will talk about staff salaries and compensation for graduate associates and give you an analysis of our FY 2002 increases. Then Larry Lewellen, associate vice president for Human Resources, will talk about our benefits costs and then end with some estimates of this year's salary market.

The next slide tells you the things that we're going to be looking at. We're going to start with our five-year history and the red column shows Ohio State and we are now ninth out of 10 in terms of total faculty raises over the last five years.

ANNUAL COMPENSATION BENCHMARKS REPORT (contd)

Vice Provost Snyder: (contd)

Last year we were sixth, when you looked at the five-year picture. Each one of those blue segments represents a year in which the raise package at that institution was five percent or greater. Eight of our 10 benchmark peers have had, in the last five years, at least one year in which the raise package was at least five percent. If you take a look at the top four schools, you'll see a very different picture from Ohio State's. Illinois had five percent plus raise packages four out of the last five years; Minnesota had two years of raise packages at eight percent or above; Wisconsin had two years with seven percent or above raises; and UCLA had three years of raise packages of at least five percent. So this is why we've slipped behind the market.

The next slide shows that for the last three years how our average faculty salaries compared to our benchmarks. If I could show you the year 1998-1999, we were sixth out of 10 then; 1999-2000, we were seventh; and last year and this year we were eighth. The numbers there on the slide show that we are very close to being ninth, in fact, about a quarter separates us from the University of Washington. The white boxes on that slide show how our faculty salaries compare to the average salary of all the benchmark peers as a group. So if you look in the white boxes, you'll see that we were 2.5 percent below the average two years ago, and last year we were 2.9 percent below the average. This year we've fallen to 5.5 percent below the average salary for our benchmark peers for faculty. And if I could show you a year beneath that, you would see that we were just 1.9 percent below in 1998-1999, so we've gone a long way in that period.

The next slide breaks this down by faculty rank and shows you our average salary for: full professors is seventh out of 10; associate professors is eighth out of 10; assistant professors is ninth out of 10. It's important to note the figure in the white boxes again, which shows for each rank how far we are behind the average salary, again, for all the benchmarks together. If you look at it that way, it's actually our average salary for associate professors that is most behind the average of our benchmark peers -- it's 6.5 percent below. Our average assistant professor's salary is six percent below the average of the benchmark group and our full professors are 4.8 percent below the average. If I could show you something that's not on this slide, you would see that last year our assistant professors were 3.7 percent below the benchmark average, associate professors were 2.8 percent below, and full professors were 2.7 percent below the average.

The next slide shows where our colleges fall relative to our benchmark peer groups. Most of the colleges have lost ground. Last year: Social Work was 14 percent behind and is now 18 percent behind the average; Dentistry was eight percent below and is now 15 percent below the average; Arts and Biological Sciences were four percent below and are now six percent below the average; Veterinary Medicine was three percent below and is now four percent below the average; Math and Physical Sciences and Food, Agricultural, and Environmental Sciences both dropped an additional two percent and are now four percent below the average; Engineering and Human Ecology were one percent below and now are four percent below the average; Humanities fell from one percent below to three percent below the average; and the Fisher College of Business last year was at the average and this year is three percent behind.

There is only one college that actually gained, relative to its benchmark peers, and it wasn't a very large gain. That is the Moritz College of Law. Last year it was 10 percent below benchmark law schools, and now it is nine percent below. So all of our colleges, except for Law, lost ground this year, and the losses range from one to seven percent.

ANNUAL COMPENSATION BENCHMARKS REPORT (contd)

Mr. J Henderson:

Currently for staff salaries, we are in a bit of a different picture. We are in the process of re-benchmarking all of our staff salaries. It is very important to us that we have accurate data, and we've actually started a process where we've looked at all of our staff positions and re-benchmarked them, confirming that either: (A) the current match that they had was correct; or (B) that we need to find a new match; or (C) where we did not have matches before, to actually come up with a match for that. Therefore, we do not have updated data at this point in time.

However, what we knew from last year is that staff was behind market in some groups by up to eight percent. Considering that and some of our preliminary data, because we've finished the first phase of the matching process, we now know we're more significantly behind than previously. That is due to two reasons: 1) the low raise package last year, which you saw a very similar pattern with faculty salaries, and we've lost ground from that; and 2) we've actually lost ground because we've actually improved a lot of our matches, and some of that increased matching has actually also come out to show us that we're further behind than we thought we were. We'll have finalized data for this next year, so I just wanted to let you know that.

Mr. McFerson:

What percentage of staff is behind the market?

Mr. Henderson:

I don't remember the exact percentage – it was about 54-60 percent before, and now we're looking at around 85 percent of staff being below the market from our preliminary report. So, it is quite a difference.

When you look at our graduate associate financial support, what we see is that Ohio State is basically at the very bottom or second from the bottom of the peers that we have here. The peers here are actually a set of AAU institutions that have agreed to be part of a data exchange group. Therefore we can't identify each institution specifically, so we've had to make it blind in terms of which institution is which. At the bottom of the slide, you can see that those institutions include Arizona, Illinois, Purdue, Indiana, and so on and so forth and you see in-state we're very close to the bottom for graduate associates.

Specifically, let's look at the benefits rate, what we contribute to them, and we also see that Ohio State is very minimal in terms of benefits support for graduate associates. On the next slide you'll see that for out-of-state graduate associates it's a very similar pattern, or very near the bottom. Actually, now we're twice removed from the bottom, but you still see the exact same pattern is happening here.

We wanted to really consider what impact our policies, our practices, and our guidelines had on different groups of Ohio State employees, both by gender and ethnicity, so that's what we're showing on the next slide. What you see here is truly a composite of all of the financial decisions we made from last year's increase process. Because we had a minimal increase in terms of budget – \$395 -- we had premium credits to help offset some of our health benefit increases. We did limited raises in certain units and we also had some bonuses. So what you see here is a composite of how that affected all these different populations.

ANNUAL COMPENSATION BENCHMARKS REPORT (contd)

Mr. Henderson: (contd)

On the top of the chart you'll see that we looked at gender, and for both faculty and classified civil service, our males and females were basically identical in terms of financial impact to those groups. For administrative and professional staff, you see that the females did about 0.4 percent better on average than their male counterparts. When you look at the bottom that's really the minority/non-minority comparison, where you see that the minority groups tended to benefit slightly more from those exact same actions that we were talking about before.

We still need to do more work in understanding all of those components individually and how they impact our faculty and staff, but this really gives you the full-blown composite shot of everything that we did. We'll continue to look at this throughout the next few years to make sure that we try to have a positive impact and we really understand what our compensation policies, practices, and guidelines are really producing here at Ohio State.

Mr. Larry Lewellen:

As we talk about compensation each year, investment in salary dollars, the Board is usually interested in what we are investing in benefit dollars and how do those costs compare to other benchmark employers. We just have one slide on this, but this focuses strictly on health care costs, which is the area of high-cost movement. We had an unprecedented increase in health care costs coming into this year, and a significant increase projected going into next year. With that, we wanted to see where we stood with other peer institutions. This data comes from the same kind of data exchange group where we can't identify the data by institution but they're listed across the bottom.

This chart shows the cost of insuring a single faculty or staff member, which is a common denominator for health care costs. When you look at Ohio State, even with these two years of increases, we are still in the lower third of the cost of providing health care insurance to faculty and staff at the University. We're not sure whether to be heartened by that or worried that our costs are going to go up further, but at least we're in the lower third at this point.

At this point, I'd like to summarize the benchmarking for FY 2002 for the year that we're in. Put simply, when you look on average for faculty and staff, our salaries are behind market, as we've shown you. When you look at the college level, 14 of the 16 colleges that we have data for are behind market, some very seriously. And the preliminary data and last year's data that we have show that all staff occupations are behind market. When we zero in on graduate associates, we know that we're among the lowest for our benchmark institutions, particularly for health care sponsorship in addition to stipends.

The next area we want to show just briefly before closing is having summarized our look at FY 2002, we'd like to share with you what we've heard from other employers, and what they're projecting for raises this summer for next year. We've gathered the data in the top two bars ourselves; the ones below come from other surveys. But to zero in at the top – the one that says IUC is the Inter-University Council – it's the four-year public universities in Ohio that operate in the same budget environment that we do; they're projecting raises in the neighborhood of 3.2 - 3.5 percent as a group. Our benchmark institutions are projecting raises that range pretty much from three percent to five percent. When you average them together, it looks like it's going to average as a group around 3.5 percent. Especially, the benchmark institutions that average around 3.5 percent are the ones we have to beat to make progress in the compensation initiative for salary comparisons.

ANNUAL COMPENSATION BENCHMARKS REPORT (contd)

Mr. Lewellen: (contd)

Below that is just a general collection of information that we have from other surveys, locally and nationally, both for faculty but especially for staff. We have staff at such a wide variety of occupations that would be recruitable both locally and nationally that we keep track of what happens to projected raise pools nationally as well. You can see that in spite of what the economy has been doing, the projections are still fairly strong for what's happening locally and nationally.

I would like to recognize Laura Gast, director of Management Information, who is the one who pulls together all of this information. She is in the audience and I would like to ask her to stand so we can recognize her and give her our appreciation for collecting all this data and putting it into this presentation -- it's so useful every year. At the Provost's pleasure, we'd be glad to entertain any questions.

Provost Ray:

Thank you, Larry. As the Board knows, we'll be returning with specific recommendations for compensation guidance for the coming year at the May Board meeting. What I did want to share with you is some of the language that we're developing for the compensation guidance that we will share with the colleges and units. This is the effort to operationalize what we say we're going to do with respect to compensation by providing some guidance to the units in their own planning with respect to compensation for next year.

There are a couple of elements that are important in establishing what the guidance language ought to be this year. The first is that the President, as he indicated again today and in his discussions with the Board and University Senate in October, talked about a commitment beginning this year, but over a number of years, for us to come forward with compensation packages that on average were in the neighborhood of up to one percent above the competitive market. We'll know after the fact, but we believe the competitive market is going to be in the range of 3 - 3.5 percent, so we're talking about a University salary pool in the neighborhood of 4.5 percent for that up to one percent above the market.

The President also in earlier remarks talked about a commitment that people who are performing well ought to make progress relative to their competitive markets, and exactly what the market is in one area or another is likely to vary. You saw that from the comparative data on how close or how far different colleges are from their markets. But to the extent that one is representatively away from the market average for his or her accomplishments and area of discipline, if one is doing well, other things equal, one would expect them to achieve at least a 3.5 percent compensation increase.

So let me share with you the key language that we're developing that I think speaks to those specific points, and then I'll stop and we'd be happy to take any questions or comments that you have. First with respect to this issue of us as an institution, "What are we doing?" The kind of language we expect to go forward with is that, "the University-wide salary budget pool target is in the range of 4.5 percent, which is expected to be one percent above market. This meets our compensation initiative goal of exceeding the average external market increase, approximately 3.5 percent, by one percent. Colleges and administrative units have been approved to provide no lower than four percent budgets and that gives the individual units some latitude to go to 4.5 - 5 percent depending upon

ANNUAL COMPENSATION BENCHMARKS REPORT (contd)

Provost Ray: (contd)

their resources and their sense of what they need to do to try to meet that local objective of being one percent above the market. As in past years, faculty being promoted will receive six percent centrally, in addition to at least an average percentage merit increase from their unit, and this is a traditional commitment we've made to people in recognition of positive tenure and promotion decisions."

Next, I'll turn to another statement that deals with this issue of performing well. "Individuals who are performing well and are representatively behind the market" -- in other words, as far behind the market as the group average in that disciplined department -- "should receive compensation increases of at least 3.5 percent, which is the expected average external market increase. Individuals with salaries obviously closer to the market could receive less."

Then the last observation I'll make since we talked about graduate associate compensation and the fact that we have some real issues there to address, is a statement of the sort that we'll be including in our compensation guidance. "That returning graduate associates with equivalent appointments are also considered to be participating in the compensation initiative. Those who are performing well should receive compensation increases consistent with the average increase in the pool."

That concludes our comments, Mr. Chairman. We'd be happy to entertain any questions or concerns.

Mr. Brennan:

Questions from the Board? Thank you very much, we expect to hear more at the next meeting. Thank all of you on the panel for your presentation.

(See Appendix XXXIX for background information, page 1047.)

--0--

Thereupon the Board adjourned to meet Friday, May 3, 2002, at The Ohio State University Longaberger Alumni House, Columbus, Ohio.

Attest:

William J. Napier
Secretary

David L. Brennan
Chairman

(APPENDIX XXXV)

Briefing Report to the Fiscal Affairs Committee

April 5, 2002

**LONG-TERM LEASES/SUBLEASES WITH YMCA FACILITIES
GAHANNA, GROVE CITY, HILLIARD, AND POWELL**

In April 2001, the University, on behalf of University Hospitals, entered into an affiliation agreement with the YMCA of Central Ohio to develop community partnerships that would enhance service delivery in the Central Ohio area. The YMCA is an important and highly valued organization in the community, and its programs complement many of the services that the Hospitals currently makes available throughout Franklin and the contiguous counties. The affiliation was reviewed and approved by the University Hospitals Board.

Business plans now have been developed for each of the four sites. The plans call for each site, at its maturity, to operate at a break-even basis. Each site is expected to see modest patient volume growth due to its proximity to the YMCA and the opportunity to introduce new clients to the University Health System. All but one of these sites replaces current Hospital leased space, and each site will provide the Hospitals with a more comprehensive therapy and wellness setting than current locations.

The terms of the leases and subleases are based on the Affiliation Agreement. The initial period of the leases and subleases will be 20 years. If the lease is terminated prior to the end of the 20-year term, the Hospitals will be responsible for the remaining lease expense but not operating expenses. If the Hospitals decides to remain beyond the 20-year period, it may do so according to the terms below and will be responsible only for operating expenses.

Each site will be approximately 4,800 square feet and will be attached to the YMCA facility at each location. The facilities will be completed within the next four years. At each site, University Hospitals will offer Rehabilitation Services that include physical therapy and aquatic therapy programs. Other programs that may be offered include comprehensive weight management, prenatal classes, and smoking cessation.

Lease Terms

- 20-year initial term.
- Base rent per site will be approximately \$70,000.00 per year for 20 years. This is the cost to amortize construction costs. The rent is being paid by the University Hospitals Rehabilitation Department.
- Powell's sublease has three renewal terms totaling 32 years with no base rent.
- The Gahanna, Grove City, and Hilliard leases each has renewal terms totaling 20 years with no base rent.

University Health System and
Office of Business and Finance

**Lease - YMCA
1155 E. Johnstown Road,
Gahanna**

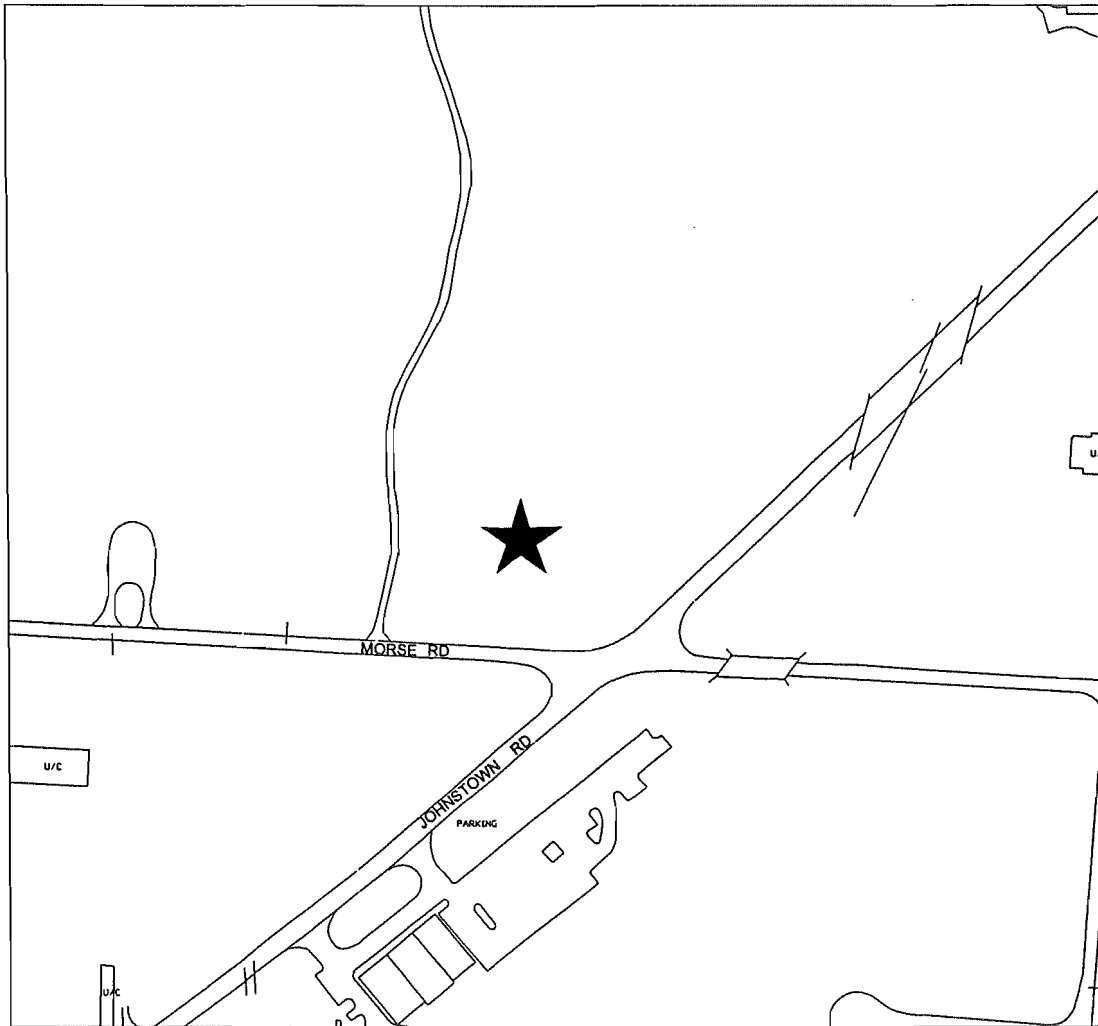

No True Scale

Office of Business and Finance
Board of Trustees Meeting
April 5, 2002

Map Provided by University Engineer's Office



**Sublease - YMCA
3600 Discovery Drive,
Grove City**

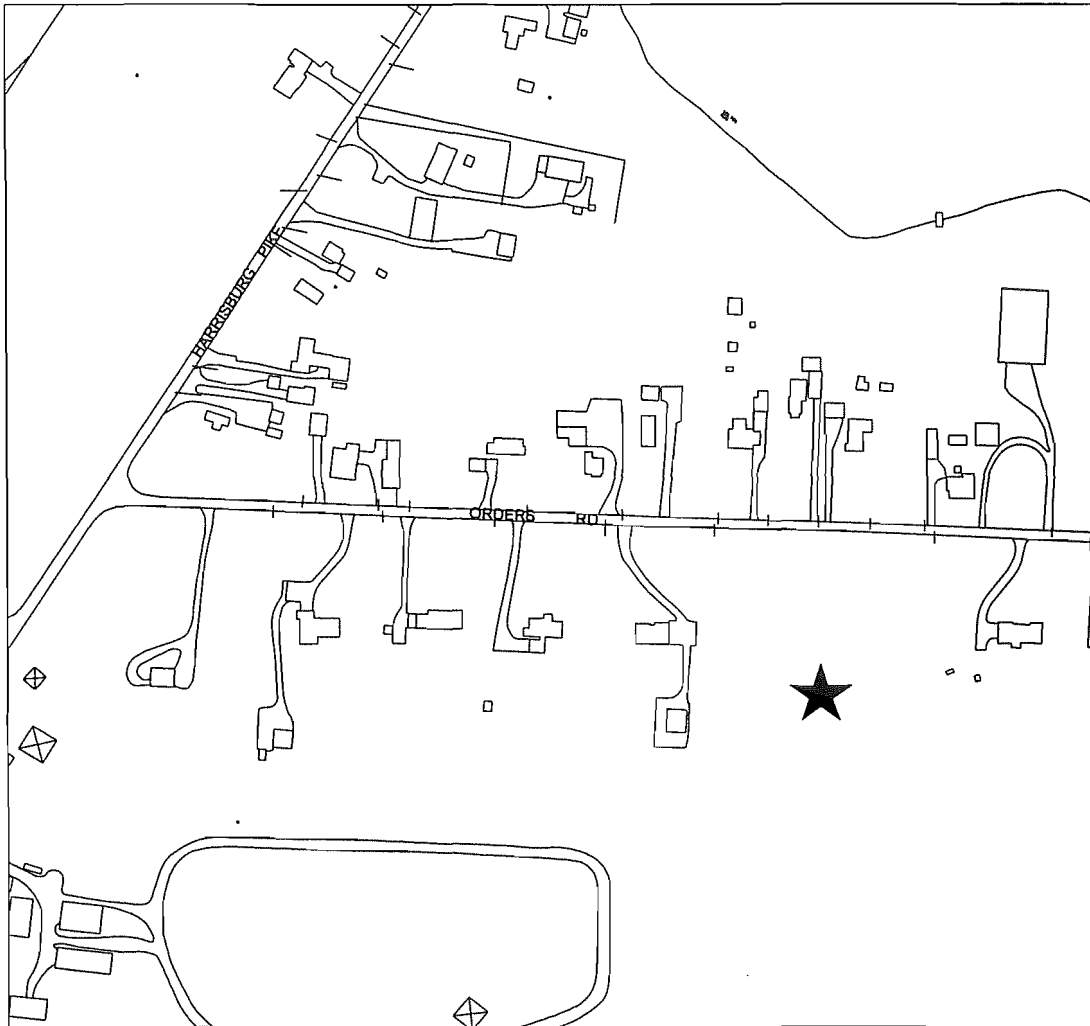

No True Scale

Office of Business and Finance
Board of Trustees Meeting
April 5, 2002

Map Provided by University Engineer's Office



**Lease - YMCA
6052 Woods View Way,
Hilliard**



No True Scale

Office of Business and Finance
Board of Trustees Meeting
April 5, 2002

Map Provided by University Engineer's Office



**Sublease - YMCA
7798 Liberty Road
Powell**



No True Scale

Office of Business and Finance
Board of Trustees Meeting
April 5, 2002

Map Provided by University Engineer's Office

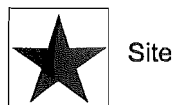

James Ambulatory Services Renovation**315-2001-924**

PROJECT CAPTAIN: Rick Van Deusen, Facilities Planning and Development - Architecture, 292-5979			
REQUESTING AGENCY: James Cancer Hospital and Solove Research Institute			
PROJECT LOCATION: 0372 - JAMES CANCER HOSP & RSCH INST, A G		AGE: 1990	GR. SQ. FT.: 268,262
PROJECT DESCRIPTION: Renovate space used by the Ambulatory Surgery Department on the first and second floors and the patient treatment areas on the ground floor.			
MILESTONES:	Projected	Revised	Actual
Arch/Eng Approved B/T	04/05/2002		
Bidding Approved B/T	04/05/2002		
Arch/Engr Contract	07/15/2002		
Schematic Design Approval	09/01/2002		
FUNDING INFORMATION:			
Auxiliaries - James Cancer Hospital	\$1,000,000		
Total	\$1,000,000		
USES:			
Construction	\$750,000		
Contingency	163,750		
Design	75,000		
APO Administration	11,250		
Total	\$1,000,000		

James Cancer Hospital - Ambulatory Services Renovations

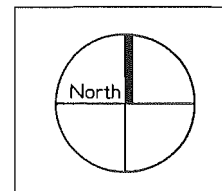
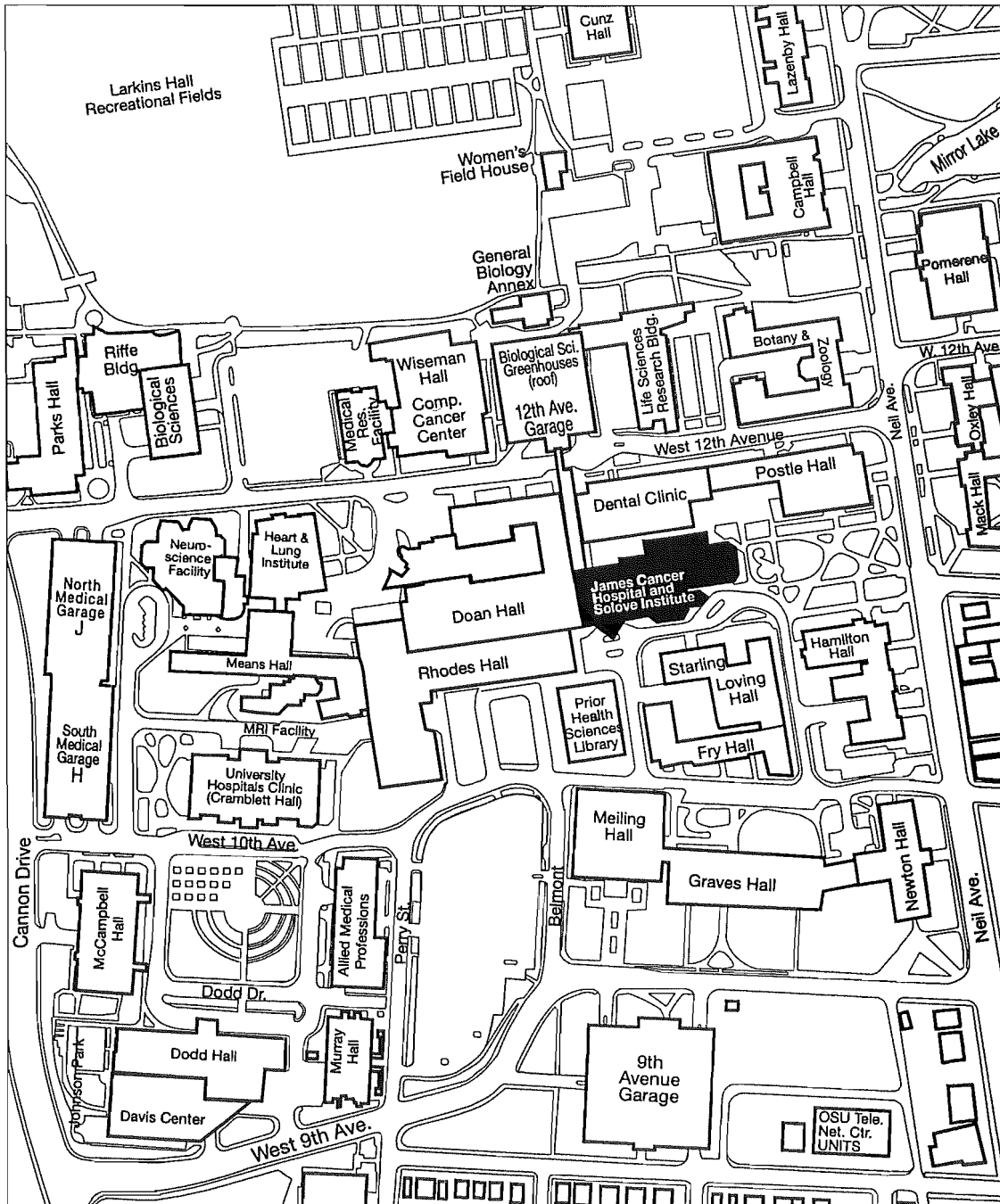

Office of Business and Finance
Office of Facilities Planning and Development

March 13, 2002

Morrison Tower / Seibert Hall Fire Alarm Syst Upgrd

315-2002-907

PROJECT CAPTAIN:			
Craig C. Henry, Facilities Planning and Development - Architecture, 292-2156			
REQUESTING AGENCY:			
Student Affairs			
PROJECT LOCATION:		AGE:	GR. SQ. FT.:
V0010 - Site - See Comments		N/A	N/A
PROJECT DESCRIPTION:			
Replace the current fire alarm system, to reduce false alarms, with new intelligent photoelectric smoke detectors and audible bases that are fully addressable with fire-print based technology			
MILESTONES:	Projected	Revised	Actual
Arch/Eng Approved B/T	04/05/2002		
Bidding Approved B/T	04/05/2002		
Arch/Engr Contract	06/14/2002		
Design Development Approval	09/27/2002		
Construction Document Approval	12/31/2002		
Bid Opening	01/30/2003		
Award of Contracts	03/14/2003		
Construction Start	03/24/2003		
Report of Award to B/T	12/05/2003		
Completion	08/29/2003		
FUNDING INFORMATION:			
Future Univ. Bond Issues	\$694,949		
Total	\$694,949		
USES:			
Construction	\$583,812		
Contingency	56,630		
Design	45,750		
APO Administration	8,757		
Total	\$694,949		
COMMENTS:			
Site is Morrison Tower and Seibert Hall in the south campus housing area.			

Morrison Tower and Siebert Hall Fire Alarm System Upgrade

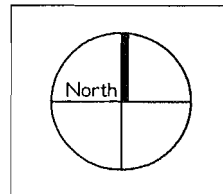
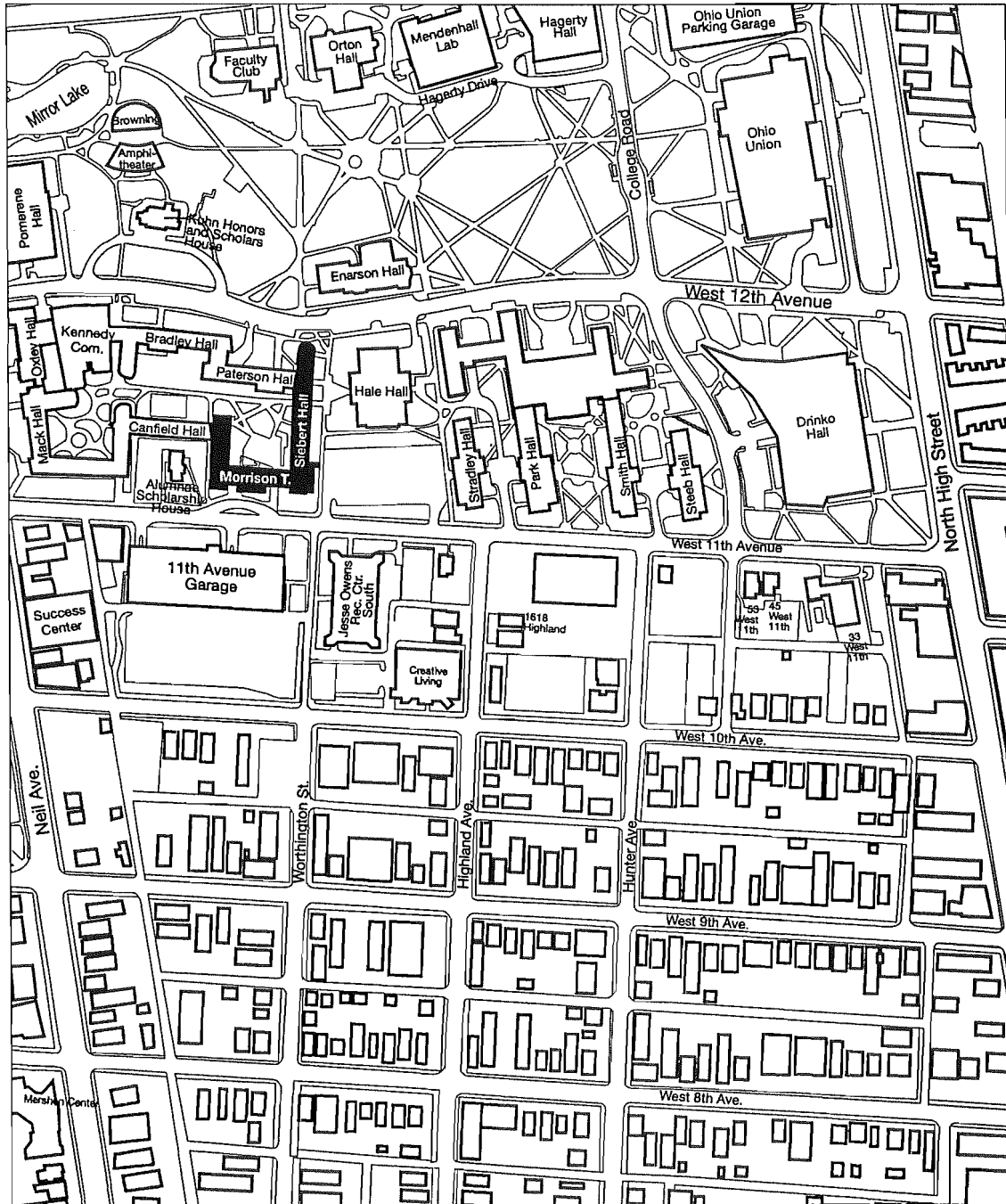

Office of Business and Finance
Office of Facilities Planning and Development

March 13, 2002

University Hospitals / Rhodes Hall Entrance

50700-R014354

PROJECT CAPTAIN: Rick Van Deusen, Facilities Planning and Development - Architecture, 292-5979			
REQUESTING AGENCY: Medical Center Administration / Facilities			
PROJECT LOCATION: 0354 - RHODES HALL-UNIVERSITY HOSPITAL		AGE: 1979	GR. SQ. FT.: 485,832
PROJECT DESCRIPTION: University Hospitals requests architectural / engineering services for design and then the construction of the entrance / expansion of Rhodes Hall.			
MILESTONES:	Projected	Revised	Actual
Bidding Approved B/T	04/05/2002		
Bid Opening	04/15/2002		
Award of Contracts	07/10/2002		
Construction Start	07/15/2002		
Report of Award to B/T	12/06/2002		
Completion	11/01/2002		
FUNDING INFORMATION:			
Auxiliaries - University Hospitals	\$270,000		
Total	\$270,000		
USES:			
Construction	\$223,500		
Contingency	21,807		
Design	20,000		
APO Administration	4,693		
Total	\$270,000		

Stone Lab Concrete Dock and Walk Renovation

315-2002-906

PROJECT CAPTAIN:

Gerald K. Pullins, Physical Facilities, 292-3377

REQUESTING AGENCY:

Department of Physical Facilities

PROJECT LOCATION:

V0007 VARIOUS LOCATIONS - REMOTE

AGE:

GR. SQ. FT.:

PROJECT DESCRIPTION:

The area serving the boat dock site for the island at Cooke Castle has deteriorated, been undercut and/or damaged by the weather and lake causing potential safety hazards for individuals wanting to access Cooke Castle. This project will renovate the dock area and walks from the dock to Cooke Castle, including ADA accessibility.

MILESTONES:

	Projected	Revised	Actual
Arch/Eng Approved B/T	4/5/2002		
Bidding Approved B/T	4/5/2002		
Arch/Engr Contract	6/15/2002		
Design Development Approval	8/1/2002		
Construction Document Approval	1/10/2003		
Bid Opening	3/1/2003		
Award of Contracts	5/1/2003		
Construction Start	5/1/2003		
Report of Award to B/T	12/5/2003		
Completion	9/1/2003		

FUNDING INFORMATION:

HB748 Columbus Basic Renovation	\$	38,362		
HB850 DAS		24,888		
Total	\$	63,250		

USES:

Construction	\$	50,000		
Contingency		7,500		
Design		5,000		
Univ. Administration		750		
Total	\$	63,250		

COMMENTS:

Stone Lab - Concrete Dock and Walk Renovation

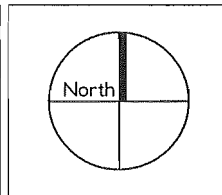
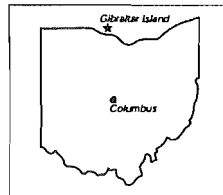
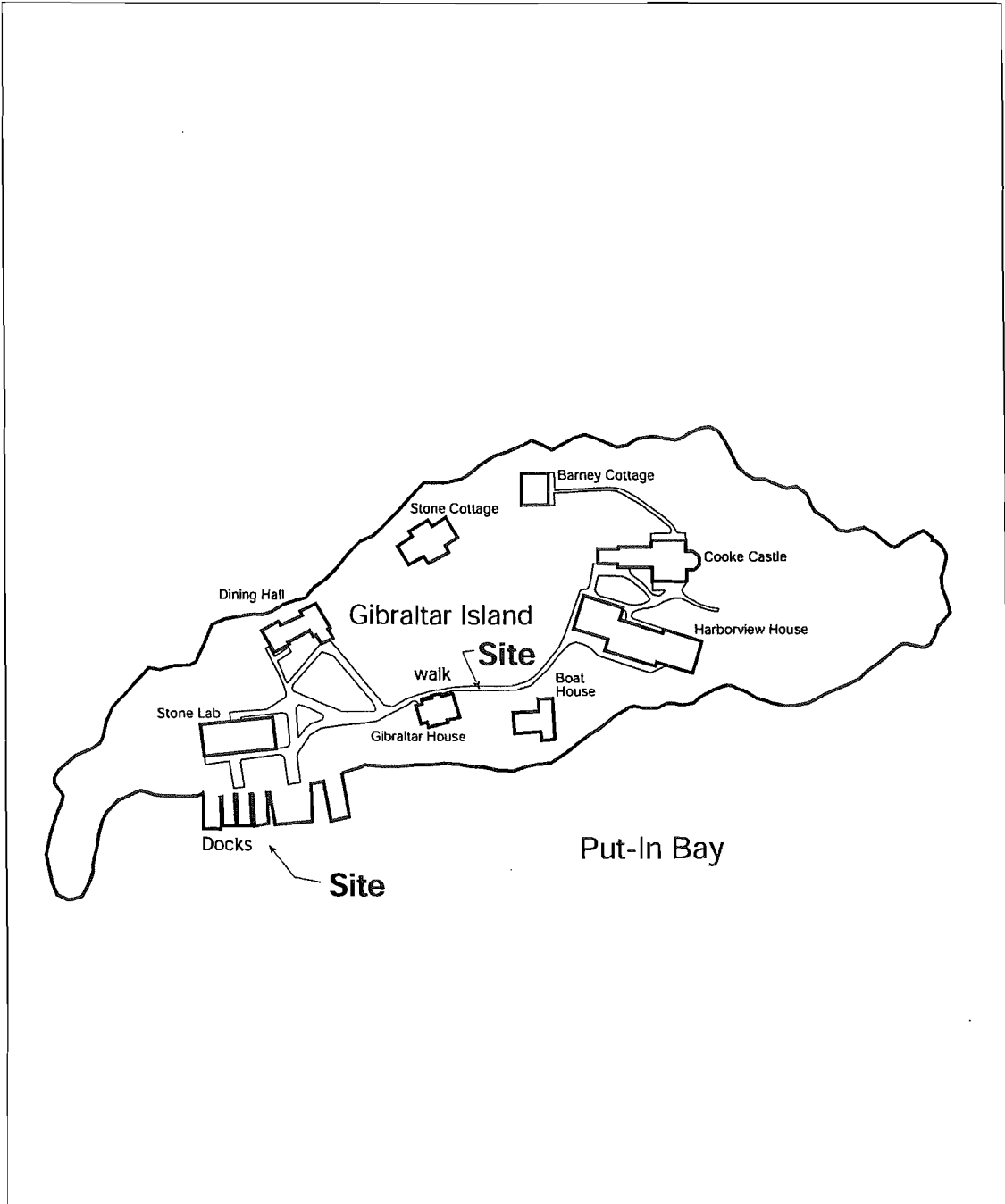

Office of Business and Finance
Office of Facilities Planning and Development

March 13, 2002

Graduate and Professional Student Housing

315-1996-976

PROJECT CAPTAIN: Marjory Trishman Spangler, Facilities Planning and Development - Architecture, 292-5704			
REQUESTING AGENCY: Housing, Food Services and Event Centers			
PROJECT LOCATION: V0010 - Site - See Comments		AGE: N/A	GR. SQ. FT.: N/A
PROJECT DESCRIPTION: This is the first phase of what is expected to be a multiple phased construction project. The project is all new construction of graduate and professional student apartments to be located in the South Campus area. The buildings will include a mix of one, two and three bedroom apartments. A limited amount of off street parking will be included.			
MILESTONES:	Projected	Revised	Actual
Arch/Eng Approved B/T	04/02/1999		04/06/1999
Bidding Approved B/T	04/02/1999		02/02/2001
Schematic Design Approval	04/03/2000	08/29/2000	08/29/2000
Design Development Approval	08/04/2000	04/16/2001	04/16/2001
Construction Document Approval	11/03/2000	10/15/2001	11/26/2001
Bid Opening	01/05/2001	12/21/2001	01/08/2002
Award of Contracts	02/25/2001	02/13/2002	02/20/2002
Construction Start	03/02/2001	02/14/2002	02/20/2002
Report of Award to B/T	04/01/2001	04/05/2002	
Completion	12/14/2001	07/18/2003	
FUNDING INFORMATION:			
Future Univ. Bond Issues	\$17,421,177	\$29,172,100	
Total	\$17,421,177	\$29,172,100	
USES:			
Construction	\$15,413,644	\$25,905,300	
Contingency	820,682	1,295,265	
Design	1,001,887	1,660,671	
Design / Constr	0	0	
APO Administration	184,964	310,864	
Total	\$17,421,177	\$29,172,100	
COMMENTS: Board of Trustees approval for bidding originally approved April 6, 1999. Authorization to bid at the higher, revised project budget received February 2, 2001. Site - Neil between 9th and 10th Avenue and along 10th Avenue between Neil and Worthington. project scope has evolved from housing for graduate and professional students to include housing for undergraduates and undergraduate scholar students as well as a limited amount of retail space. The total project budget has been revised to \$29,172,099.95 to support the increased project scope, based upon the pro-forma figures developed by the using agency.			

Graduate and Professional Student Housing

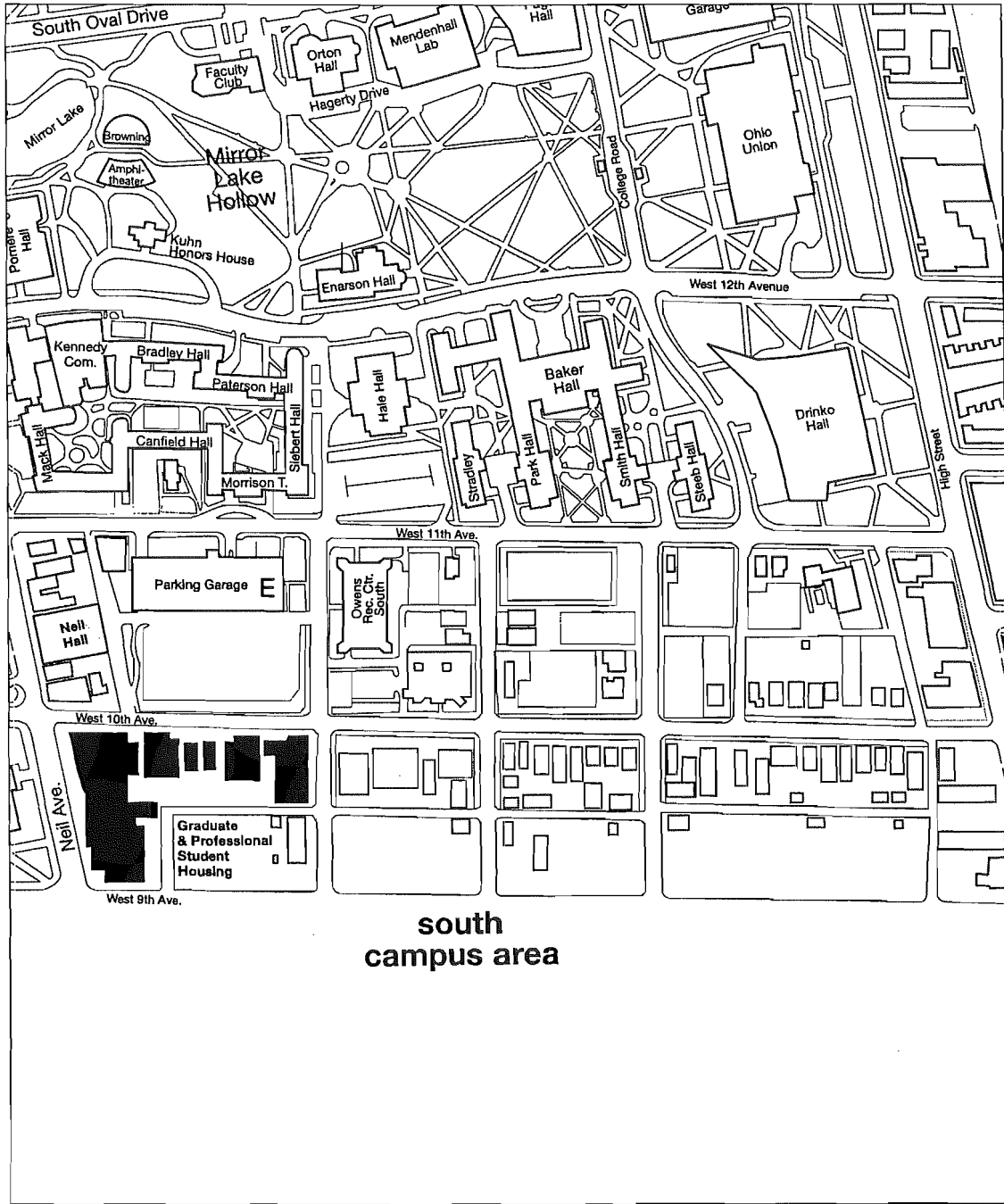

south
campus area

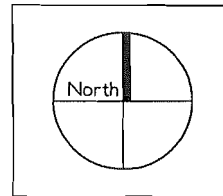

Office of Business and Finance
Office of Facilities Planning and Development

March 13, 2002

University Hospital East Muscular Skeletal Program

315-1999-945

PROJECT CAPTAIN: Rick Van Deusen, Facilities Planning and Development - Architecture, 292-5979			
REQUESTING AGENCY: University Hospitals			
PROJECT LOCATION: 0397 - UNIVERSITY HOSPITALS EAST		AGE: N/A	GR. SQ. FT.: N/A
PROJECT DESCRIPTION: Evaluate the building space, provide programming, and renovate the areas of surgery, in-patient, out-patient, and support activities to provide space for the Muscular Skeletal Program.			
MILESTONES:	Projected	Revised	Actual
Arch/Eng Approved B/T	06/04/1999		06/04/1999
Bidding Approved B/T	06/04/1999		02/04/2000
Arch/Engr Contract	07/15/1999	01/03/2000	02/08/2000
Construction Document Approval	09/30/1999	07/15/2000	08/10/2000
Bid Opening	10/31/1999	09/15/2000	10/11/2000
Construction Start	12/01/1999	12/11/2000	12/13/2000
Report of Award to B/T	12/03/1999	04/05/2002	
Completion	06/30/2000	07/28/2003	
FUNDING INFORMATION:			
Auxiliaries - University Hospitals	\$3,000,000	\$10,900,000	
Total	\$3,000,000	\$10,900,000	
USES:			
Asbestos	\$45,000	\$135,000	
Construction	\$2,500,000	\$1,127,220	
Contingency	200,000	307,482	
Design	225,000	1,538,000	
Electric	0	2,362,570	
General	0	2,554,120	
HVAC	0	1,842,630	
JOC Administr.	0	3,542	
JOC Constr.	0	282,536	
Mechanical	0	56,745	
Plumbing	0	582,155	
APO Administration	30,000	108,000	
Total	\$3,000,000	\$10,900,000	
COMMENTS: The project budget has increased to incorporate an expanded project scope including additional phases. Revised project scope and budget approved by the Board of Trustees in February 2000. The construction of this project is to be phased. The construction start date reflects the beginning of the first phase whereas the completion date reflects the end of the final phase.			

Wetland Research and Education Building

315-1999-951

PROJECT CAPTAIN:

Ruth Miller, Facilities Planning & Development - Architecture, 292-4240

REQUESTING AGENCY:

Natural Resources - FAES

PROJECT LOCATION:

0222-WETLAND RESEARCH & EDUCATION BLDG

AGE:

N/A

GR. SQ. FT.:

N/A

PROJECT DESCRIPTION:

Construct a Wetland Research and Education Building to serve as a catalyst for Ohio to provide national leadership in wetland ecology and management, wetland and river restoration and ecotechnology, and continue the collaboration among several Ohio universities working in these fields. The building will house laboratories, an operations theater to monitor the activity in the wetlands, display areas, offices, computer room, work room, library/records room, reception and administration areas, kitchenette, restrooms, and garage.

MILESTONES:	Projected	Revised	Actual
Arch/Eng Approved B/T	9/1/1999		9/1/1999
Bidding Approved B/T	9/1/1999		9/1/1999
Arch/Engr Contract	4/1/2000	1/15/2001	1/10/2001
Schematic Design Approval	1/15/2001		1/16/2001
Design Development Approval	4/1/2001		1/16/2001
Construction Document Approval	7/1/2001	2/28/2001	2/28/2001
Bid Opening	10/1/2001	11/28/2001	12/12/2001
Award of Contracts	2/1/2002	3/12/2002	
Construction Start	2/2/2002	4/1/2002	
Report of Award to B/T	2/1/2002	4/5/2002	
Completion	4/1/2003	6/1/2003	

FUNDING INFORMATION:

Hayes Review Panel - BOR	\$ 1,000,000	\$ 1,180,000	
Development - OARDC		629,107	
Development - Food, Agr. & Env. Sci.		229,380	
Development - Agriculture Admin	1,809,713		
Total	\$ 2,809,713	\$ 2,038,487	

USES:

Artwork	\$ 28,000	\$ -	
Construction	1,766,151		
Contingency	355,462	163,953	
Design	156,292	155,325	
Electric		138,500	
Equipment	470,262		
General		1,108,600	
HVAC		298,000	
Plumbing		94,435	
Univ. Administration	33,546	19,674	
Utilities		60,000	
Total	\$ 2,809,713	\$ 2,038,487	

COMMENTS:

The project is being planned in phases so that additional funding can be obtained while the building shell is being constructed. Site is the Wetland Research Park, a 30 acre site located at 352 Dodridge Road.

Wetland Research and Education Building

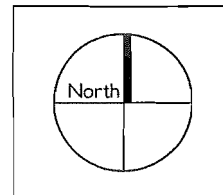
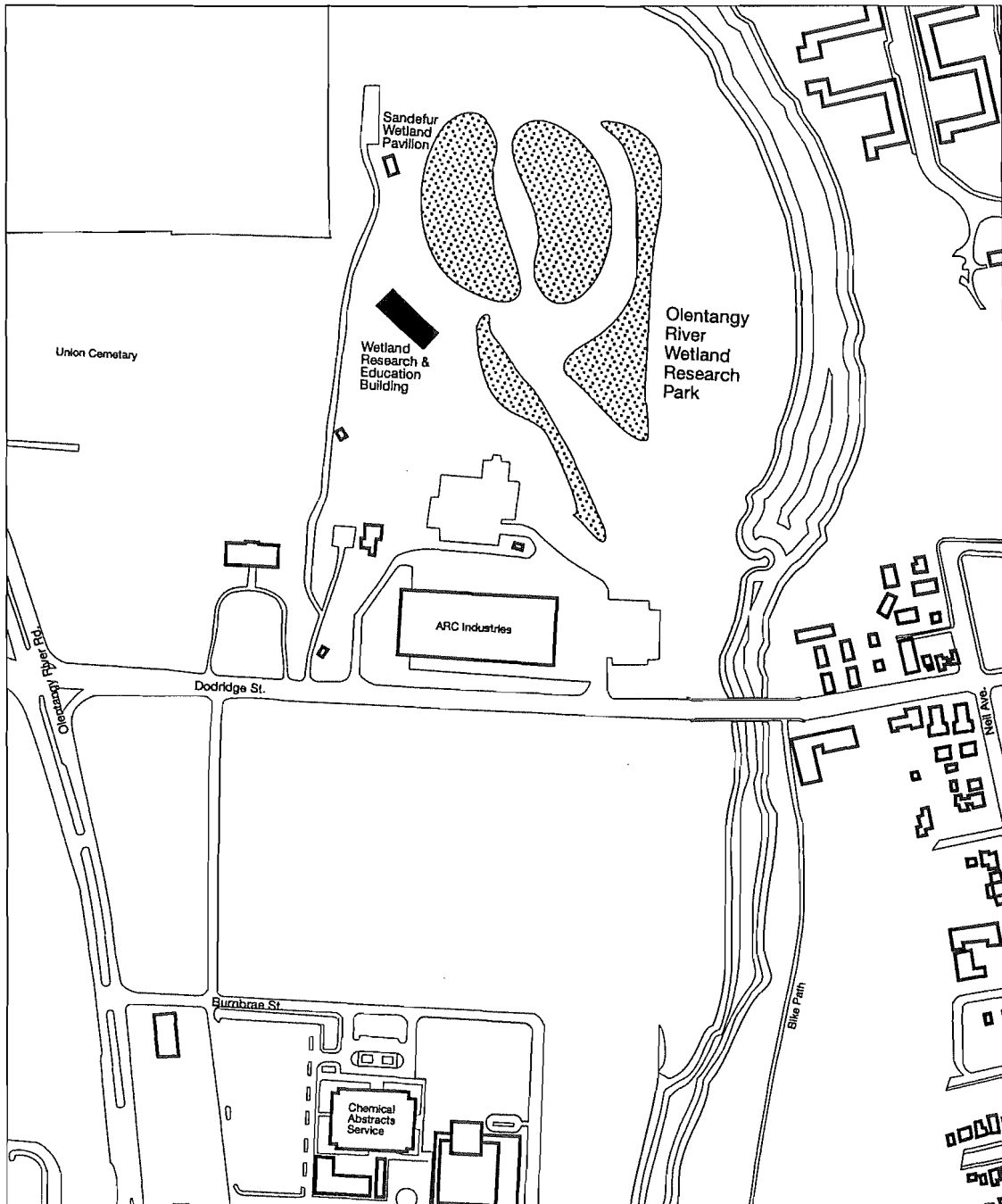

Office of Business and Finance
Office of Facilities Planning and Development

December 9, 2000

South Campus High Rise - Fire Alarm System Repl.

315-2000-963

PROJECT CAPTAIN:			
Craig C. Henry, Facilities Planning & Development - Architecture, 292-2156			
REQUESTING AGENCY:			
Housing, Food Service, and Event Centers			
PROJECT LOCATION:		AGE:	GR. SQ. FT.:
V0001 - Various Locations - Columbus		N/A	N/A
PROJECT DESCRIPTION:			
Replace the existing fire alarm systems in Steeb Hall, Smith Hall, Park Hall and Stradley Hall with new intelligent Photoelectric Smoke Detectors and audible bases, that are fully addressable with Fire-Print based technology. The systems will also be upgraded to be ADA compliant and provide an upgraded intercom system and fire fighter phones.			
MILESTONES:	Projected	Revised	Actual
Arch/Eng Approved B/T	11/03/2000		11/03/2000
Bidding Approved B/T	11/03/2000		11/02/2000
Arch/Engr Contract	02/28/2001	08/15/2001	08/17/2001
Schematic Design Approval	06/19/2001	10/16/2001	10/15/2001
Design Development Approval	06/19/2001	10/16/2001	10/15/2001
Construction Document Approval	09/03/2001	12/31/2001	12/05/2001
Bid Opening	12/04/2001	01/24/2002	01/31/2002
Award of Contracts	01/31/2002	02/28/2002	
Construction Start	03/04/2002		
Report of Award to B/T	02/01/2002	04/05/2002	
Completion	08/31/2002	12/31/2002	
FUNDING INFORMATION:			
Future Univ. Bond Issues	\$1,541,760		
Total	\$1,541,760		
USES:			
Construction	\$1,280,000	\$1,063,900	
Contingency	129,000	366,893	
Design	117,400	98,200	
APO Administration	15,360	12,767	
Total	\$1,541,760	\$1,541,760	

South Campus High Rise - Fire Alarm System Replacement

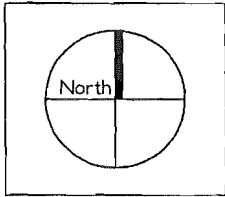
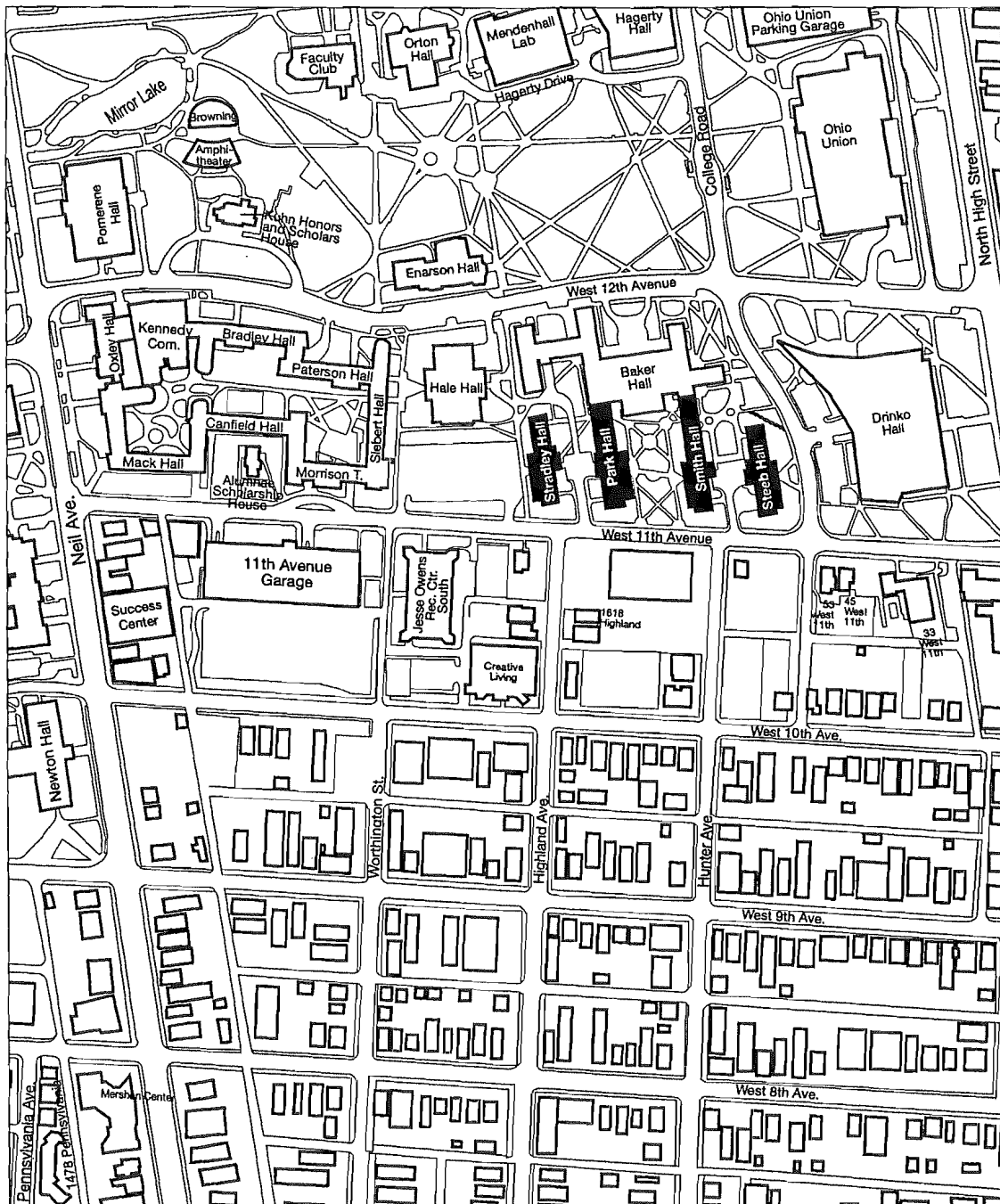

Office of Business and Finance
Office of Facilities Planning and Development

December 9, 2000

(APPENDIX XXXVII)

**SALE OF LAND AND GRANT OF TEMPORARY CONSTRUCTION LICENSES
TO THE CITY OF COLUMBUS**

**LANE AVENUE ROAD WIDENING PROJECT
APPROXIMATELY NINE ACRES ON LANE AVENUE, COLUMBUS, OHIO**

Background

Location and Description

The City of Columbus will widen Lane Avenue and install a series of streetscape enhancements between Olentangy River Road and High Street. This is a joint project with Franklin County, which is replacing the Lane Avenue Bridge. The University has been asked to sell approximately 7.15 acres to the City for the permanent public right-of-way and to grant the City temporary construction licenses to an additional approximately 2.22 acres in the area of the proposed improvements.

Appraisals and Consideration

A limited scope MAI appraisal, completed in May 2001 by Nash Wilson Associates valued the University land on the south side of Lane Avenue needed for the project at \$1,143,000. The City will pay the University \$1,080,000 for the temporary and permanent right of way. In addition, the University also owns property on the north side of Lane Avenue (site of the Cooker Restaurant). There, approximately 0.010 acre will be sold for the road-widening project at the appraised value of \$25,850. The sale of this project will be for cash; it is not part of the trade of land for project enhancements. Costs for due diligence, appraisals, and fees are expected to be approximately \$40,000.

Use of the Property

The University and the City have joined in a partnership to provide a series of significant streetscape enhancements for this important road project. Rather than accepting cash for the right-of-way needed on the south side of Lane Avenue, the University will contribute the \$1,080,000 in right-of-way payment, and the City will contribute \$400,000, for these enhancements. The project enhancements will include the burial of utility lines, widened sidewalks, decorative street lamp poles and mast arms, street trees, and supporting infrastructure.

The 7.155 acres to be sold to the City includes 2.055 acres located under the bridge. A permanent license to this property, appraised at \$169,000, was granted to Franklin County (as authorized by the Board of Trustees in August 2001). The University already has agreed to receive the fair market value for this land through enhancements provided by the County.

Grant of Temporary and Permanent Property Rights for Public Right-of-Way Lane Avenue Improvement Project *Jesse Owens east to High Street*

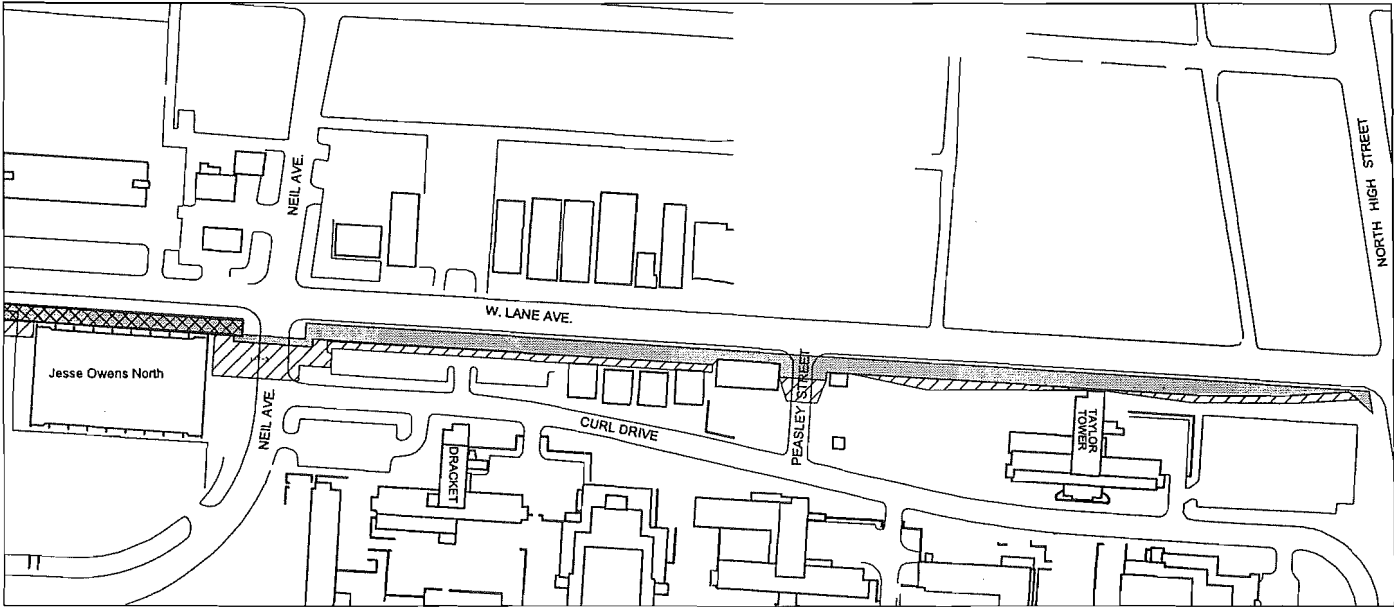

No True Scale



Office of Business and Finance
Board of Trustees Meeting
April 5, 2002

Map Provided by University Engineer's Office

- Temporary
- 1975 Easement
- Fee Title to City

Grant of Temporary and Permanent Property Rights for Public Right-of-Way Lane Avenue Improvement Project *Olentangy River east to Jesse Owens*

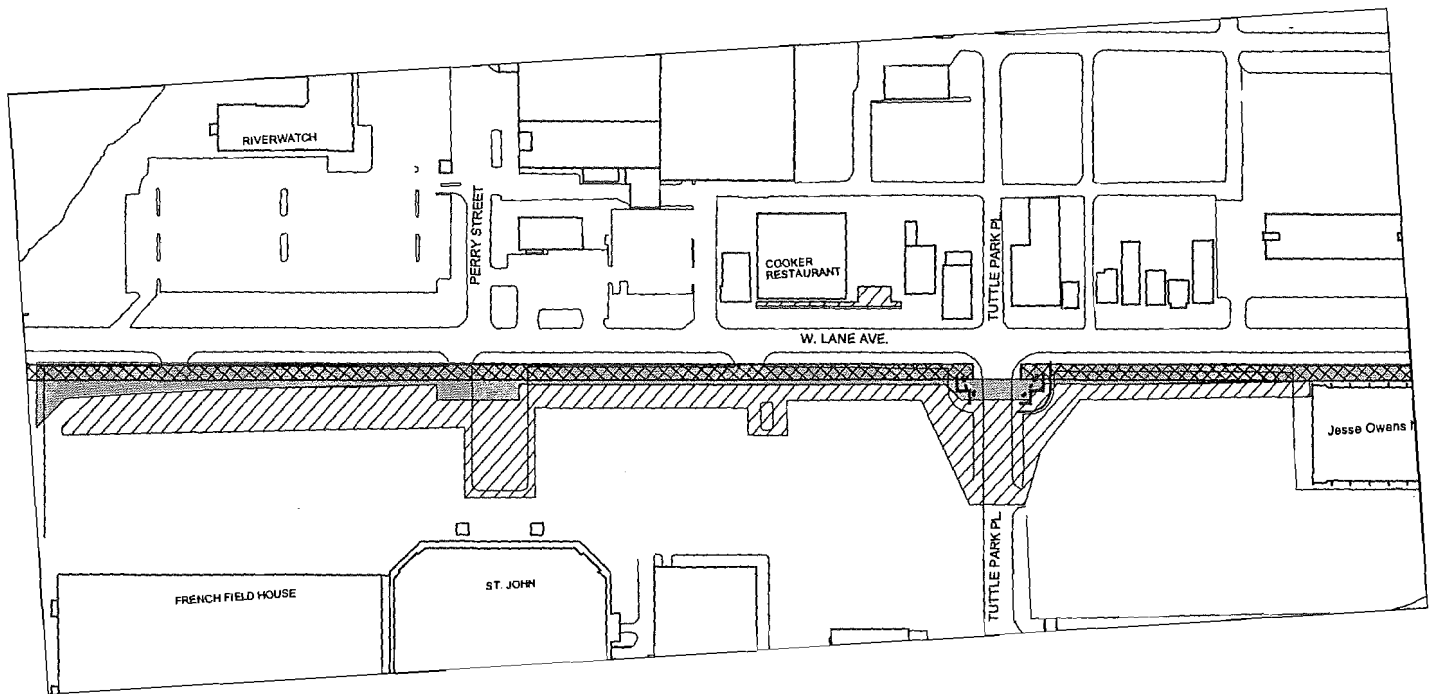



No True Scale



Map Provided by University Engineer's Office

Office of Business and Finance
Board of Trustees Meeting
April 5, 2002

-  Temporary
-  1975 Easement
-  Fee Title to City

Grant of Permanent Property Rights for Public Right-of-Way Lane Avenue Improvement Project

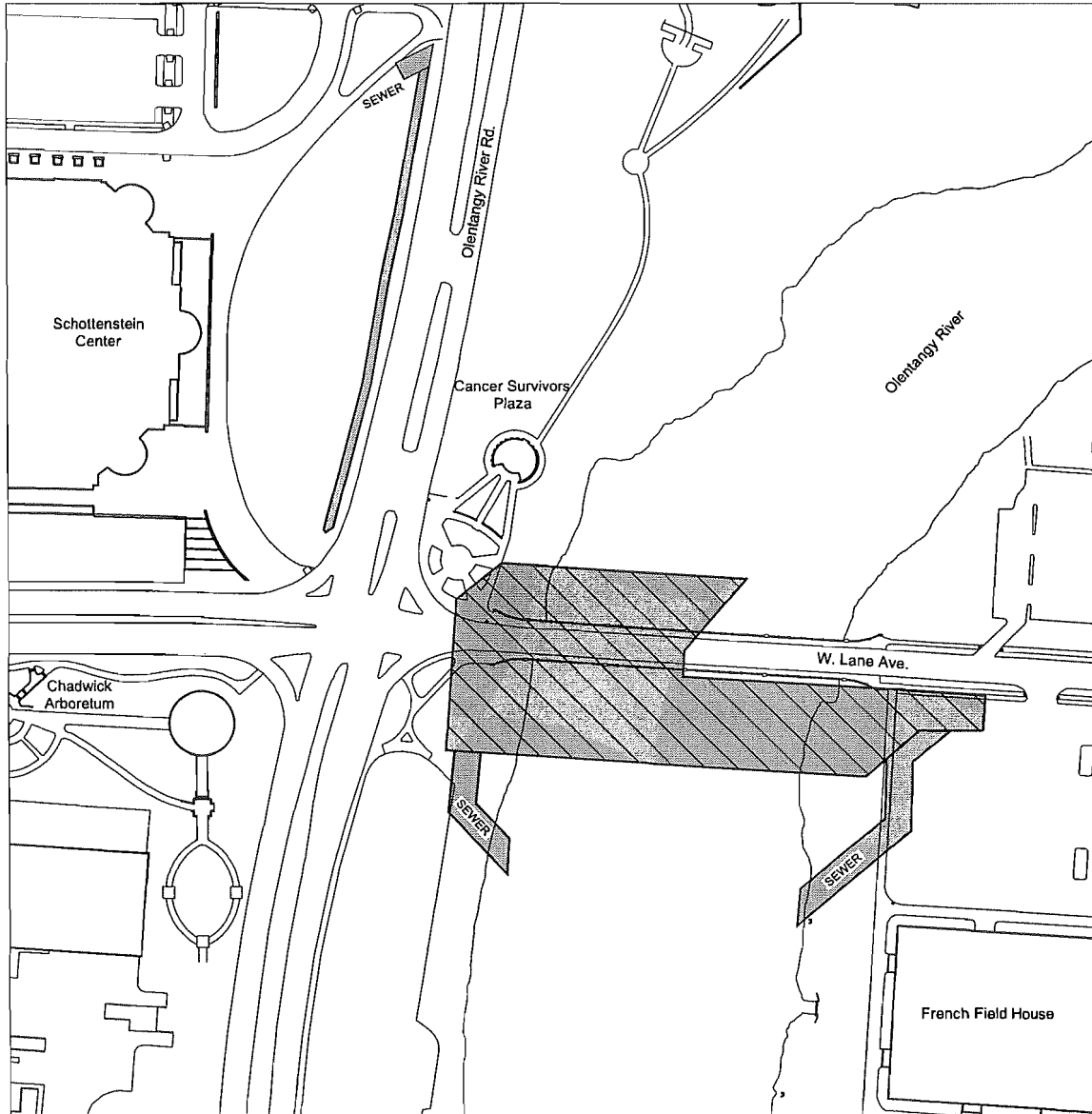



No True Scale



Map Provided by University Engineer's Office

Office of Business and Finance
Board of Trustees Meeting
April 5, 2002

-  Fee Title to City
-  Held by Franklin County in perpetual license

(APPENDIX XXXVIII)

**2002-2003 TUITION INCREASES FOR
ATI, REGIONAL CAMPUSES, AND NON-RESIDENT SURCHARGE**

TOPIC:

FY 2003 Regional Campuses and ATI Undergraduate Tuition Increases and University-wide Undergraduate Non-resident Surcharge.

CONTEXT:

The Board approved in March the instructional and general fees for undergraduate students enrolled at the Columbus Campus for FY 2003 effective Summer Quarter. Since then the Regional Campus Boards of Trustees have met and recommend tuition increases for their campuses and the Executive Dean of the College of Food, Agricultural, and Environmental Sciences is recommending fee increases for ATI effective Summer Quarter 2002.

The Regional Campuses tuition recommendations took into consideration:

- Currently, tuition at Ohio State's Regional Campuses (\$3,606 per year for a full-time lower division student) is higher than any of Ohio's other regional campuses and 7% above the average of Ohio's other regional campuses.
- Undergraduates on the Columbus campus will pay approximately 1/3 more in tuition than undergraduates on a regional campus in FY 2003.
- Between Autumn of 1998 and the present, Access credits made it possible to keep the increase for a lower division student's tuition to only \$26.
- Regional Campuses state support including Access Challenge funds was cut by 6% in FY 2002 (after a 5% cut in FY 2001). That reduced level of State support carried forward into FY 2003, thus reducing the ability to buy down regional campus tuition costs.
- Regional Campuses follow the same compensation increase policies as Columbus campus.
- The growing gap between tuition and service expectations at the regional campuses compared to the Columbus Campus being addressed by the Regional Campus Commission.

As part of the solution to the Columbus Campus FY 2003 resource gap discussed at the March Board meeting the non-resident surcharge for undergraduates on all campuses is recommended to increase by 7.5% effective Summer Quarter 2002. This increase will generate \$3 million in revenue (\$1 Million more than the traditional 5% increase).

HIGHLIGHTS:

- **Access Challenge FY 01–02 down 10%:** After significant increases in statewide Access Challenge since FY 1998, it decreased 5% from FY01 to FY02 and was cut another 6% in October, for a cumulative cut of 10%. Funding remains flat in FY03.

Year	Statewide Access	% Change
FY 03	\$58,831,920	0%
FY 02	58,831,920	-10%
FY 01	65,268,000	85%
FY 00	35,313,691	77%
FY 99	20,000,000	67%
FY 98	12,000,000	

- **Regional Campuses and ATI Tuition Table**

The strategy of applying more of the Access Challenge fee reduction to lower division tuition is meant to keep tuition low for access students and to keep the differential between Regional Campuses and Columbus Campus tuition lower at the upper division, so as

1. not to discourage students from changing to the Columbus Campus, and
2. not to worsen our competitive position relative to other Regional Campuses and community colleges. (This latter becomes relevant because of student housing.)

Undergraduate Fees Per Quarter for a Full-Time Student						
	Fiscal Year 2002			Fiscal Year 2003		
	Total	Access Credit	Student Share	Total	Access Credit	Student Share
Regional Lower-Division	\$1,397	\$ (195)	\$1,202	\$1,509	\$ (200)	\$1,309
Regional Upper-Division	\$1,397	\$ (107)	\$1,290	\$1,509	\$ (54)	\$1,455
ATI	\$1,397	\$ (195)	\$1,202	\$1,504	\$ (183)	\$1,321

- **Undergraduate Non-resident Total Tuition**

The Non-resident surcharge for undergraduate students enrolled at all campuses will increase by 7.5% or \$219 per quarter (\$657 per year) for a full-time student effective Summer Quarter 2002.

FY 2003 Annual Columbus Campus Undergraduate Tuition Summary			
	Instructional & General Fees	Nonresident Surcharge	Total
FY 2002 Base Fees	\$4,761	\$8,766	\$13,527
FY 2003			
Continuing Student Fees	\$5,190	\$9,423	\$14,613
\$ Increase	\$ 429	\$ 657	\$ 1,086
% Increase	9.0%	7.5%	8.0%
New Student Fees	\$5,664	\$9,423	\$15,087
\$ Increase	\$ 903	\$ 657	\$ 1,560
% Increase	19.0%	7.5%	11.5%

RECOMMENDATIONS:

1. Resident undergraduate instructional and general fees at the Regional Campuses will increase 8% or \$112 per quarter for full-time undergraduate students effective Summer Quarter 2002. These fees will be reduced by Access Challenge credits in the amount of \$200 per quarter for full-time lower division students and \$54 per quarter for full-time upper division students, bringing the total net fee increase for lower division students to 8.9% and for upper division students to 12.8%. For all students, the increases average just under 10%.
2. Resident undergraduate instructional and general fees net of Access Challenge at ATI will increase by 9.9% or \$119 per quarter for full-time undergraduate students effective Summer Quarter 2002.

3. The Non-resident surcharge for undergraduate students enrolled at all campuses will increase by 7.5% or \$219 per quarter for a full-time student effective Summer Quarter 2002.

ACTION REQUEST OF FISCAL AFFAIRS COMMITTEE:

Approval of the recommended FY 2003 Regional Campuses and ATI Tuition Increases and Non-resident Surcharge for all campuses

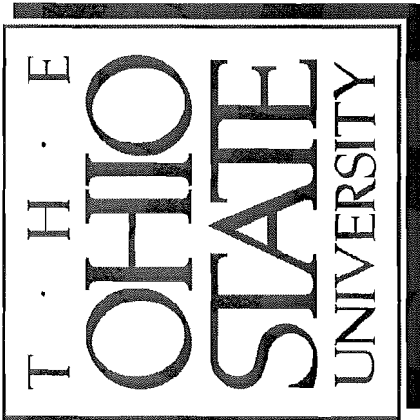

Compensation Benchmarks

Report to the Board of Trustees

April 5, 2002

Office of Human Resources



Critical Questions:

- How does our five-year history of raises compare with benchmark institutions?
- How do our current salaries compare with benchmark institutions?
- How are we investing our salary dollars?
- How do our benefits costs compare with other institutions?
- What is the market outlook for raises for FY 2002-03?



How does our five-year history of raises compare with benchmark institutions?

- Five year increase budget history

The Ohio State University Public Benchmark Institutions Faculty Salary Increase Budget 1997-98 through 2001-02

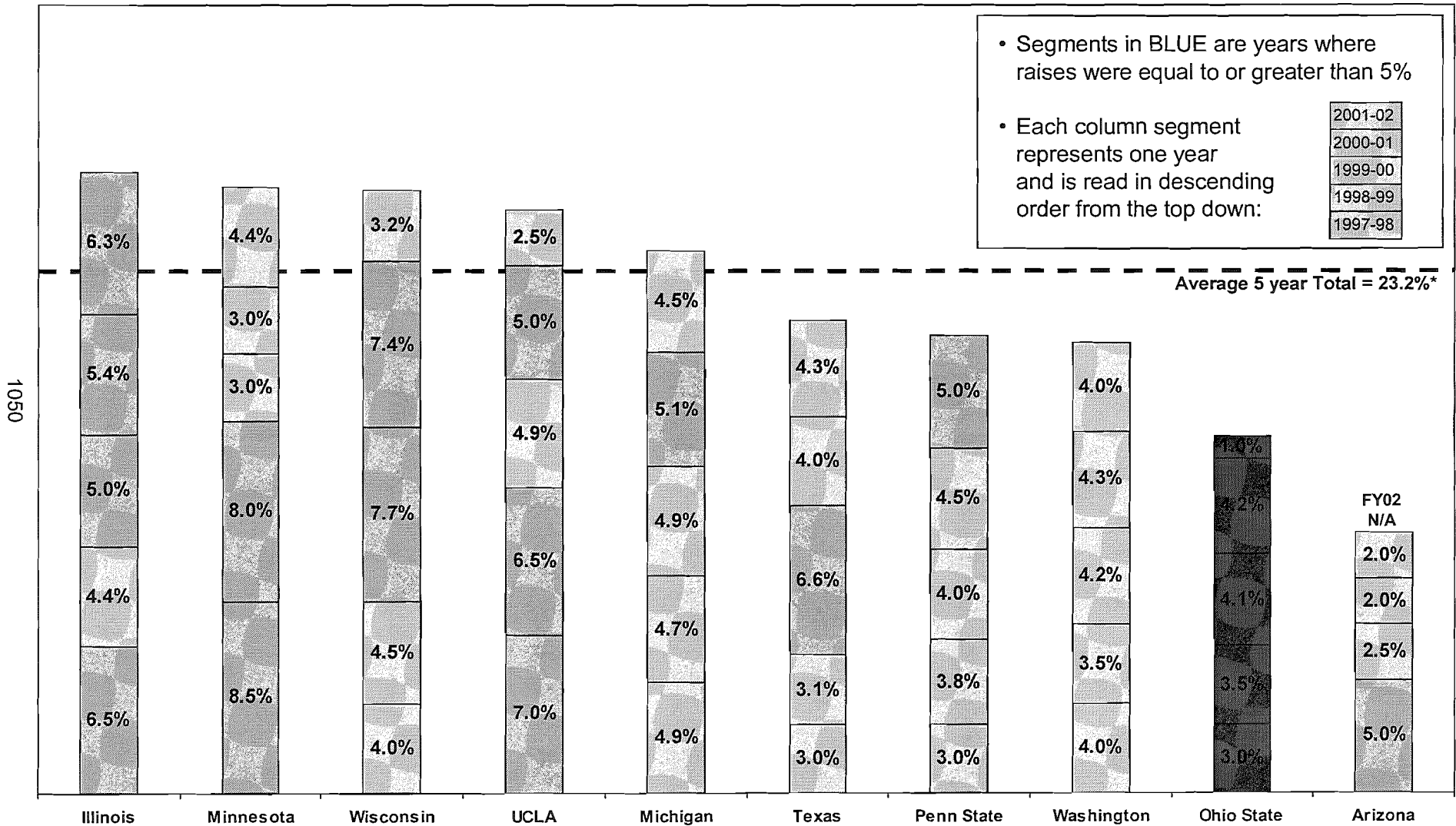

* Average includes benchmark institutions and Ohio State (excluding Arizona)



How do our current salaries compare with benchmark institutions?

- Faculty Compensation:
 - ↓ Comparative salary analysis, 1999 - present
 - ↓ Salary analysis by rank
 - ↓ Salary analysis by college
- Staff Compensation
- Graduate Associate Financial Support

The Ohio State University Comparative Faculty Salary Analysis Benchmark Universities Overall Average Salaries (in Thousands)

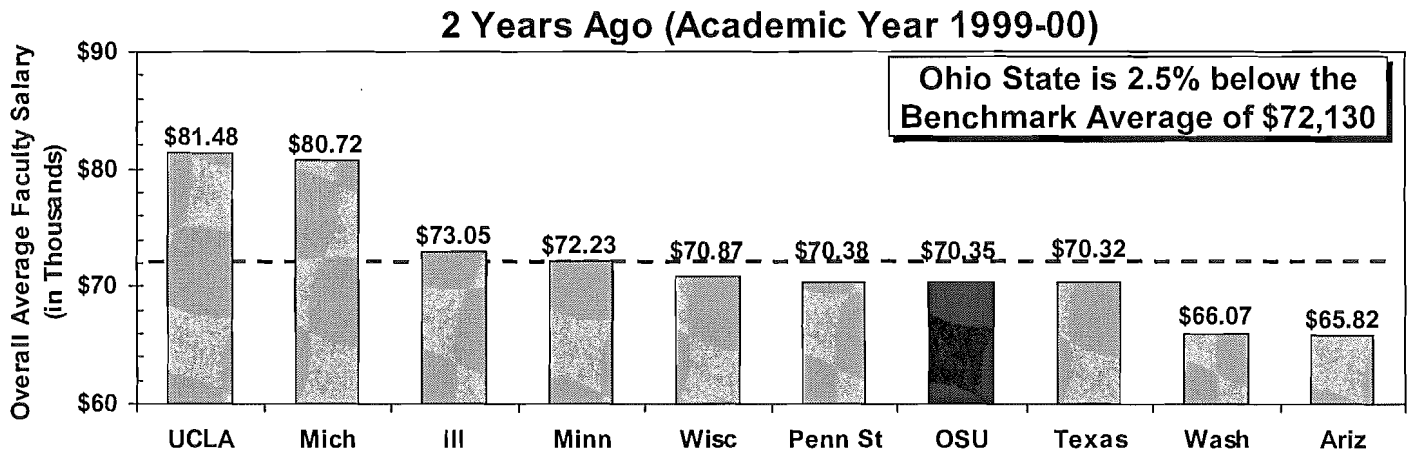
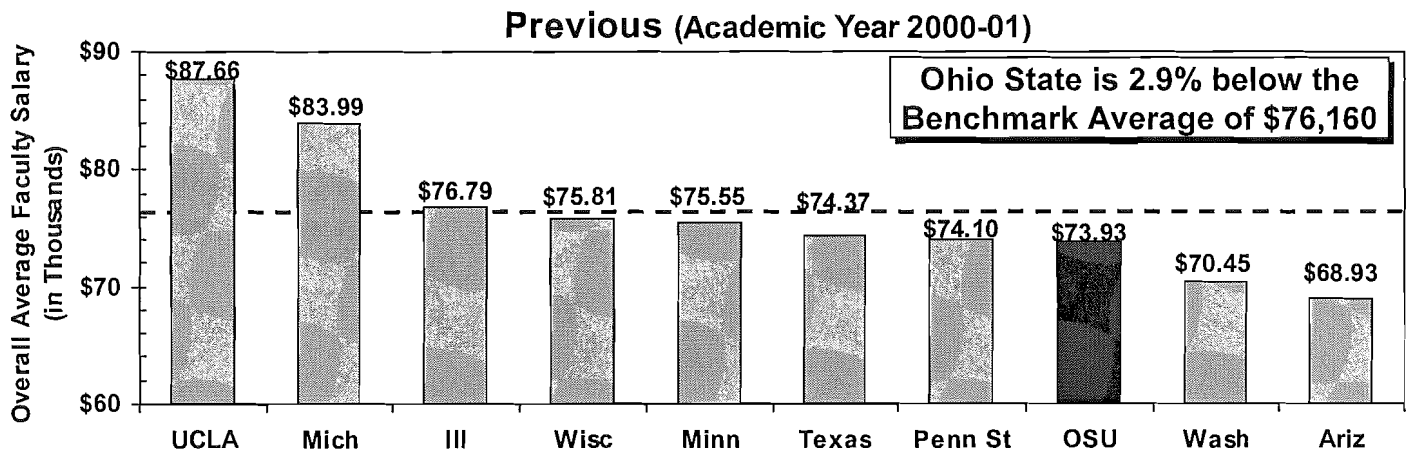
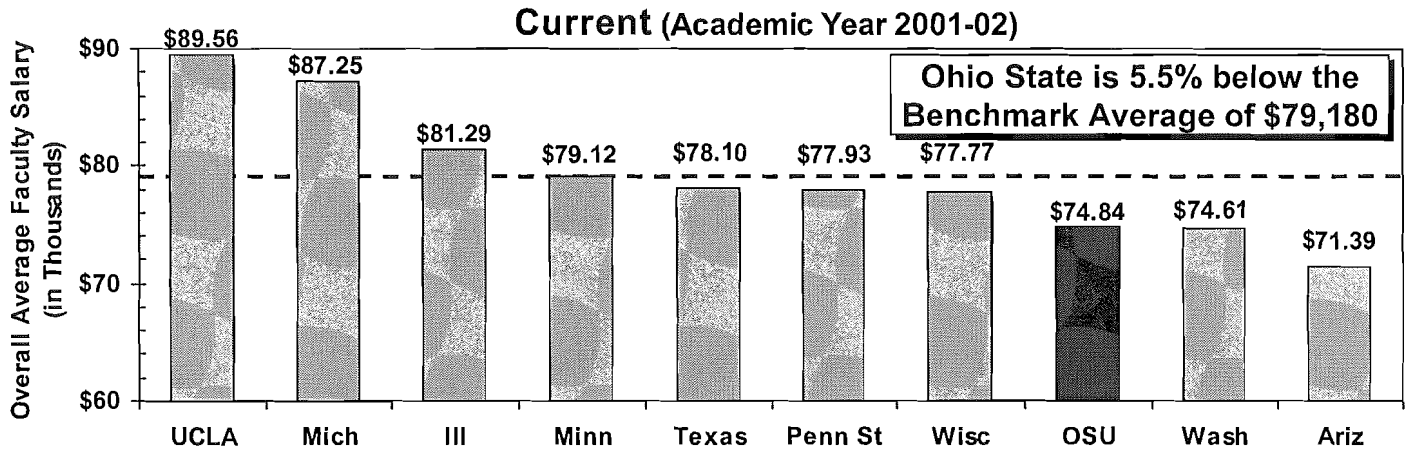

The Ohio State University Comparative Faculty Salary Analysis Benchmark Universities

Academic Year 2001-02 Average Salaries by Rank (in Thousands)

Full Professors

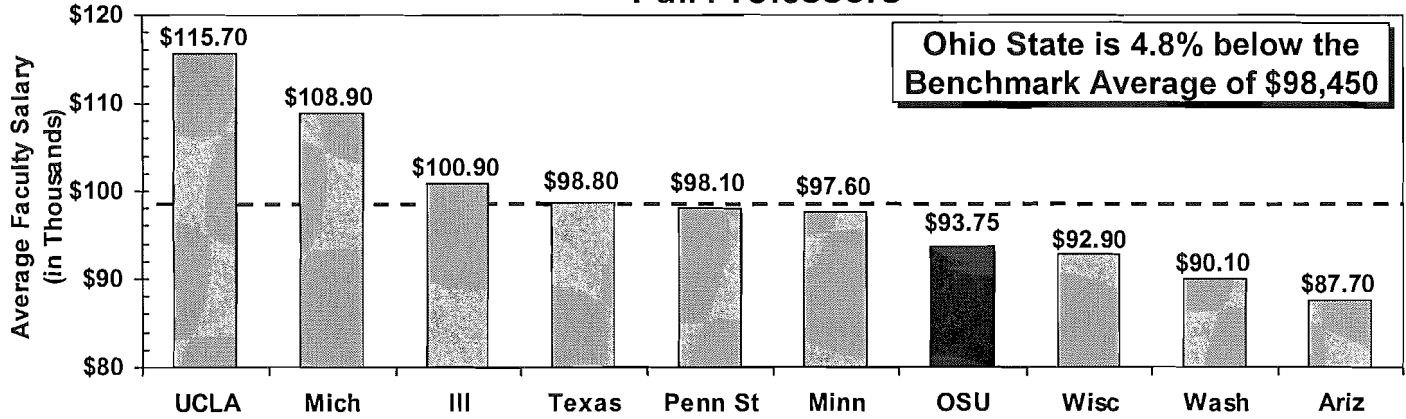

Associate Professors

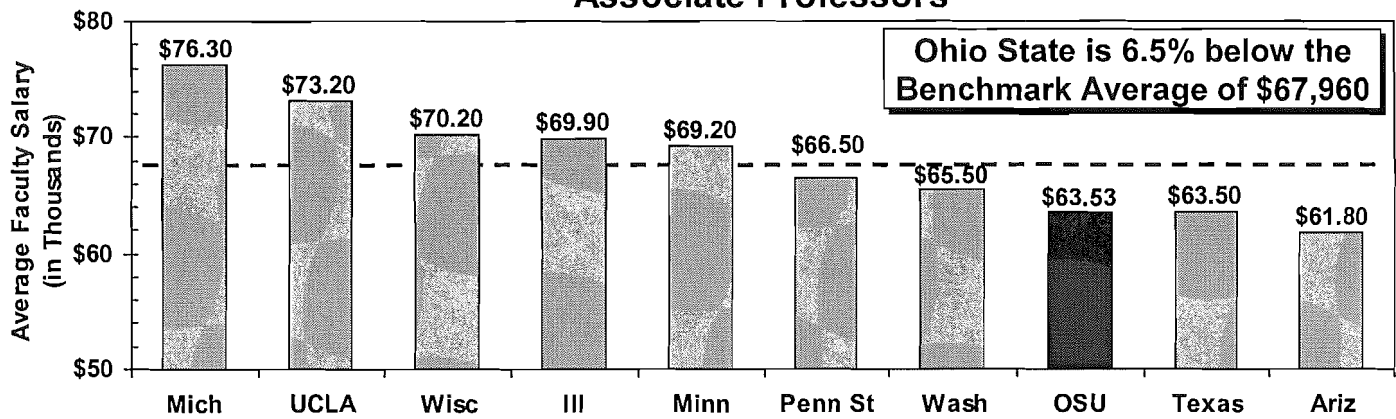

Assistant Professors

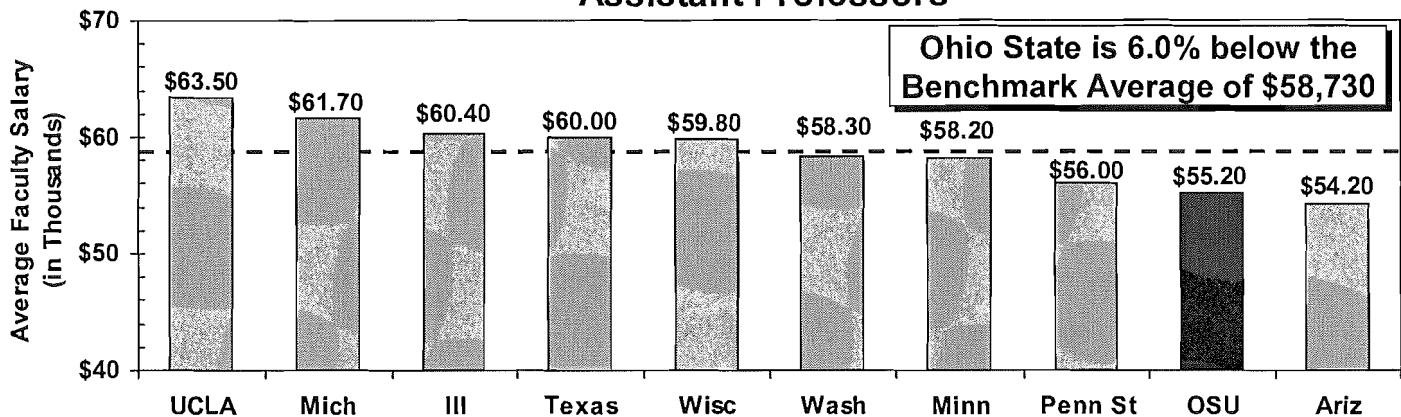

The Ohio State University Faculty Salary by College 2001-02 Comparison with Public Benchmark Universities*

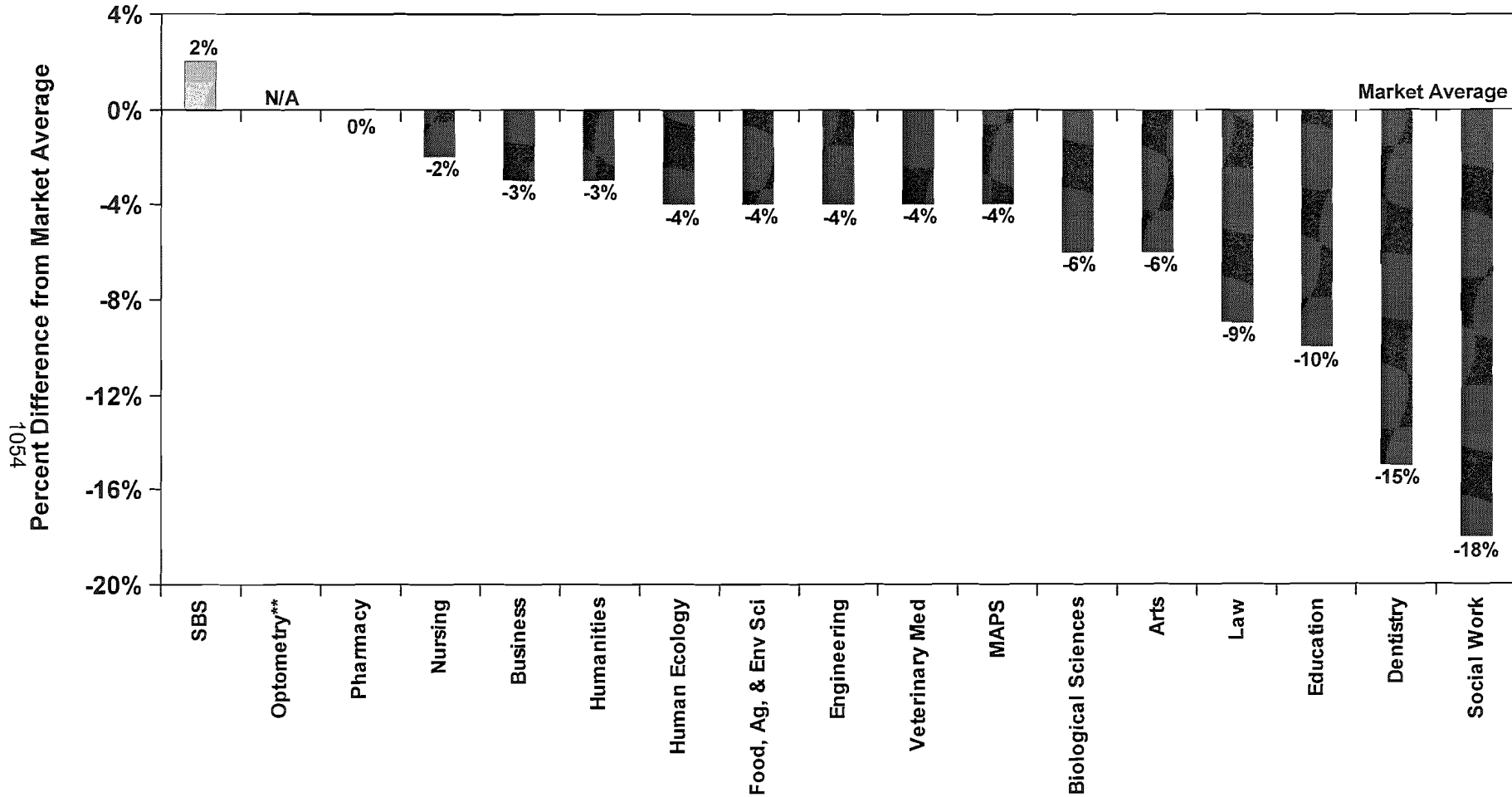

Notes: Percentage > 0 indicates average salary above market average.

** Optometry's percentage is 0 because there are no other institutions in the benchmark group for this college.

2001-02 salaries unavailable so 2000-01 salaries were aged using each institution's 2001-02 average faculty salary increase.

* Public Benchmark Universities (Excluding College of Medicine):

Ohio State	Illinois #	Minnesota #	Texas-Austin	Washington
Arizona	Michigan #	Penn State	UCLA	Wisconsin



Staff Salary Data Analysis

- OSU is in the midst of comprehensive staff benchmarking process, therefore updated data for staff salary comparisons is not currently available.
- In Fiscal Year 2001-02, staff were below market with some groups below by as much as 8%.
- Preliminary data suggest that staff will be further behind market; this is not only due to low raises last year, but also to the increased number of positions with market information.
- Finalized data will be available during the next year.

The Ohio State University
Summary of Graduate Associate Financial Support - Resident Students
Benchmark and Public CIC Institutions
Average Net Financial Support and Medical Benefits for Autumn 2001

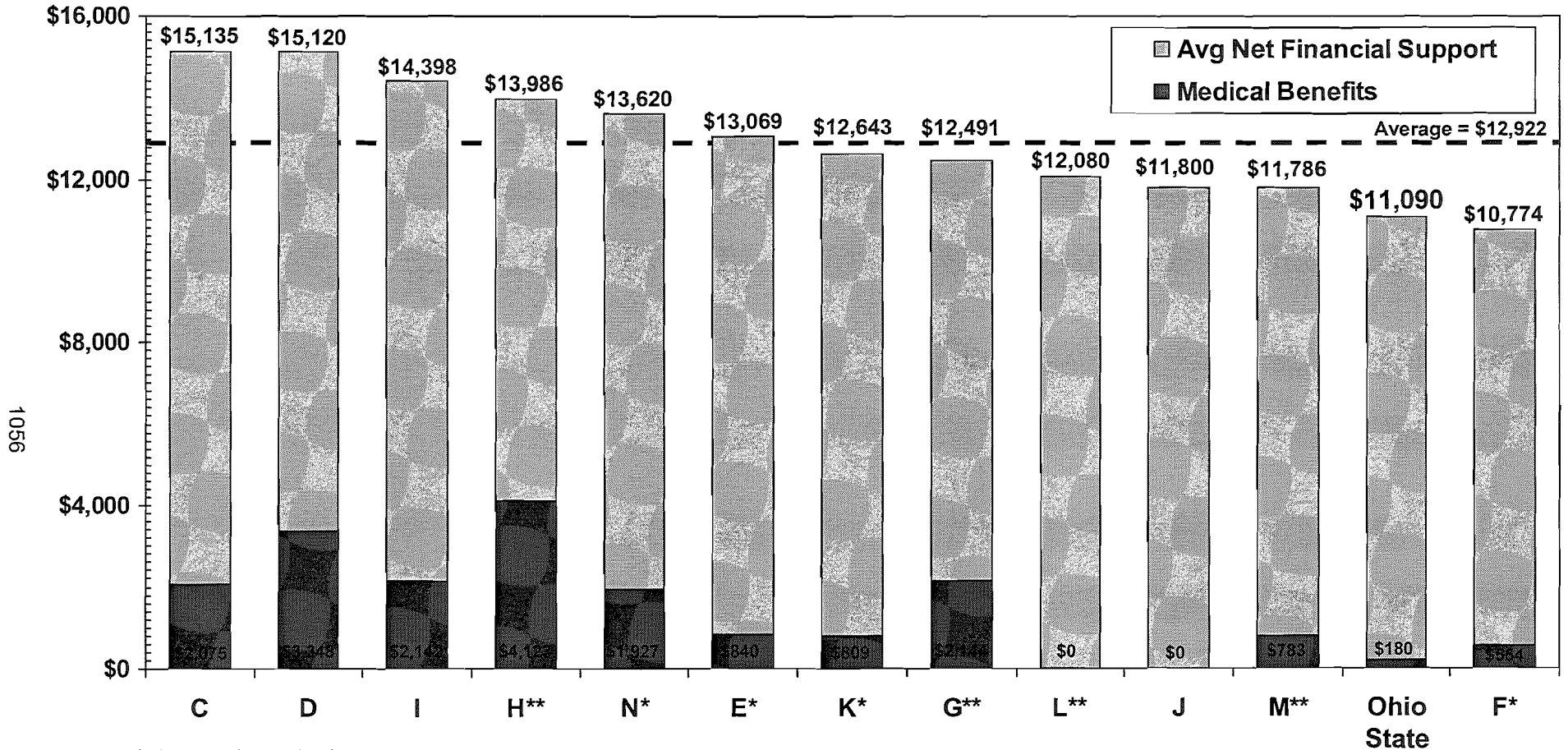

Notes: * Non-Benchmark Institutions.
 ** Stipend, fee and fee authorization data for Texas, Minnesota, Arizona and UCLA are as of AU 2000, as data for AU 2001 was unavailable.
 Data represents information for 9/10 month appointments.
 Average Net Financial Support = Stipend + Medical Benefits - Fees.
 Medical: Where multiple plans available, most common plan is reflected. If range of premiums, midpoint reflected.
 Premiums represent composite of 80% single / 20% family coverage. UCLA's premium from AU 1998.
 UCLA's fees and fee authorization are based on 12 credit hours vs. 9 for other institutions.

Institutions include: Arizona Illinois Indiana Iowa Michigan Michigan State Minnesota
 Ohio State Purdue Texas UCLA Washington Wisconsin

The Ohio State University
Summary of Graduate Associate Financial Support - Nonresident Students
Benchmark and Public CIC Institutions
Average Net Financial Support and Medical Benefits for Autumn 2001

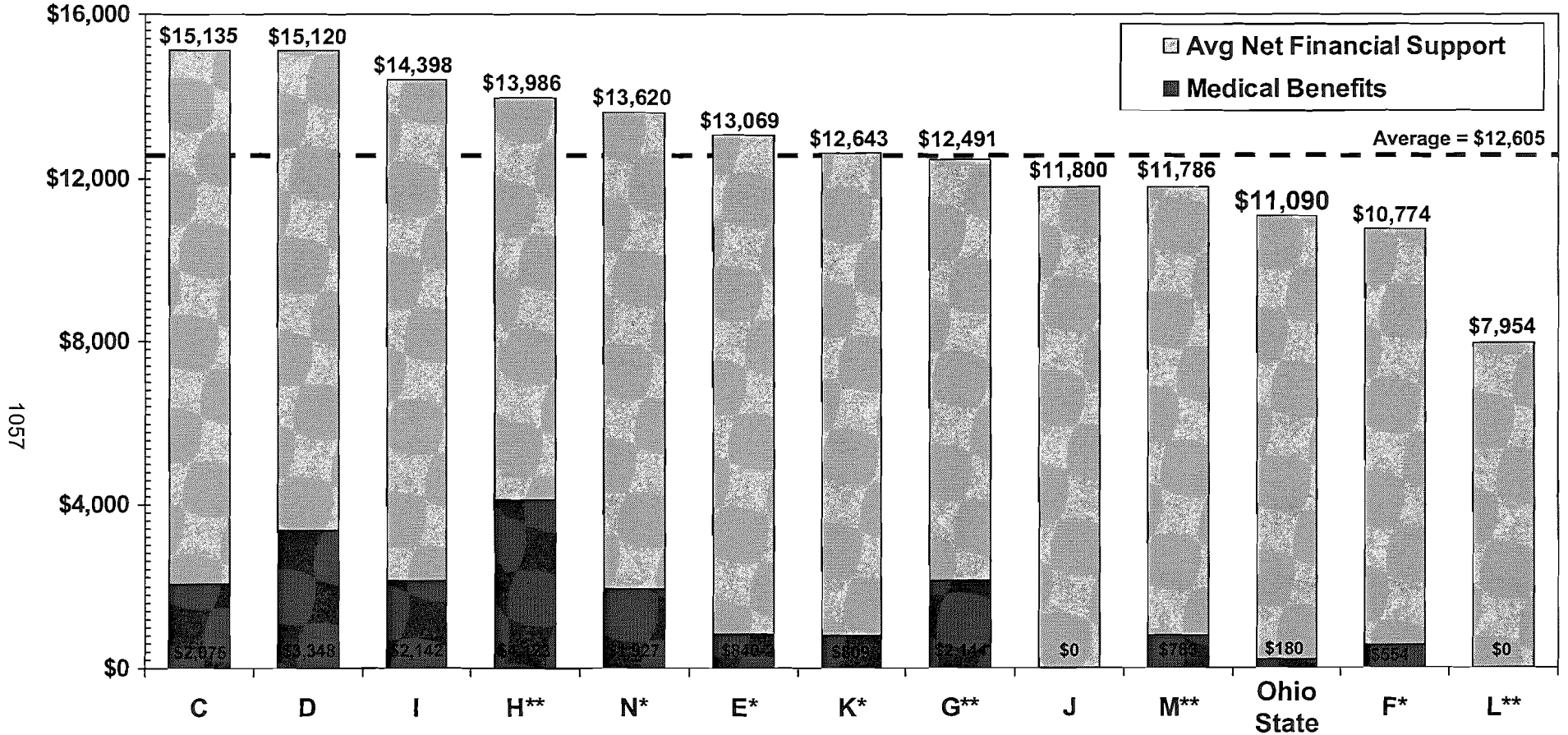

Notes: * Non-Benchmark Institutions.
 ** Stipend, fee and fee authorization data for Texas, Minnesota, Arizona and UCLA are as of AU 2000, as data for AU 2001 was unavailable.
 Data represents information for 9/10 month appointments.
 Average Net Financial Support = Stipend + Medical Benefits - Fees.
 Medical: Where multiple plans available, most common plan is reflected. If range of premiums, midpoint reflected.
 Premiums represent composite of 80% single / 20% family coverage. UCLA's premium from AU 1998.
 UCLA's fees and fee authorization are based on 12 credit hours vs. 9 for other institutions.

Institutions include: Arizona Illinois Indiana Iowa Michigan Michigan State Minnesota
 Ohio State Purdue Texas UCLA Washington Wisconsin

Sources: AAUDE Survey of Graduate Stipends, 2000-01 and 2001-02; medical premiums and parking fees - phone/web.

Office of Human Resources



How are we investing our salary dollars?

- FY 2001-02 total investments by classification - gender and ethnicity

**The Ohio State University
 FY 2001-02 Compensation Process
 FINANCIAL IMPACT OF ALL COMPONENTS
 (\$395 + Premium Credit + Unit Raises + Unit Bonuses)
 All Funding Sources**

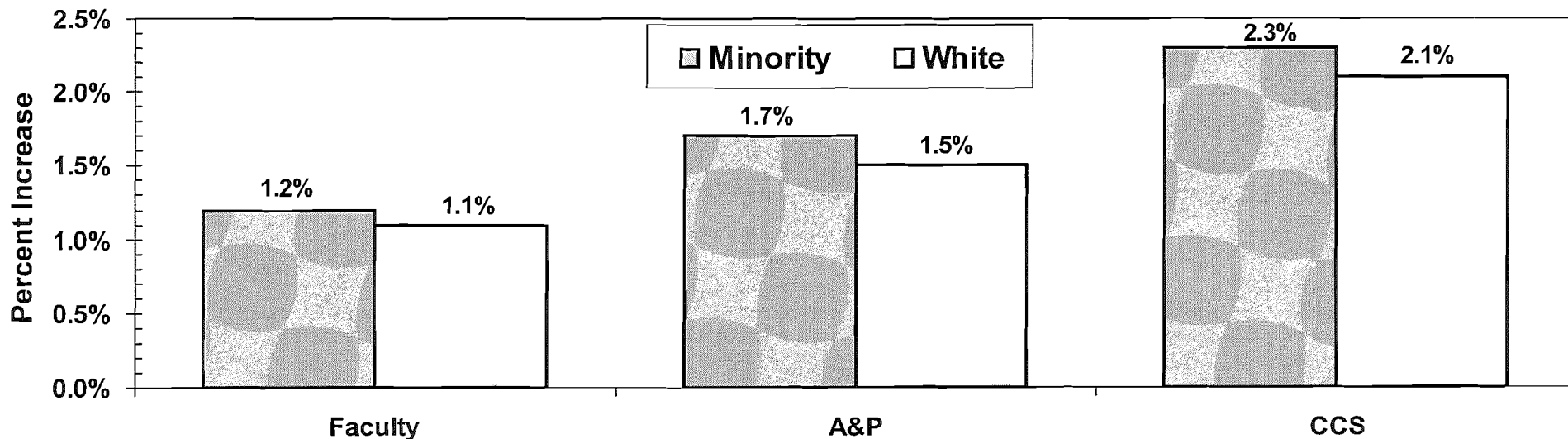
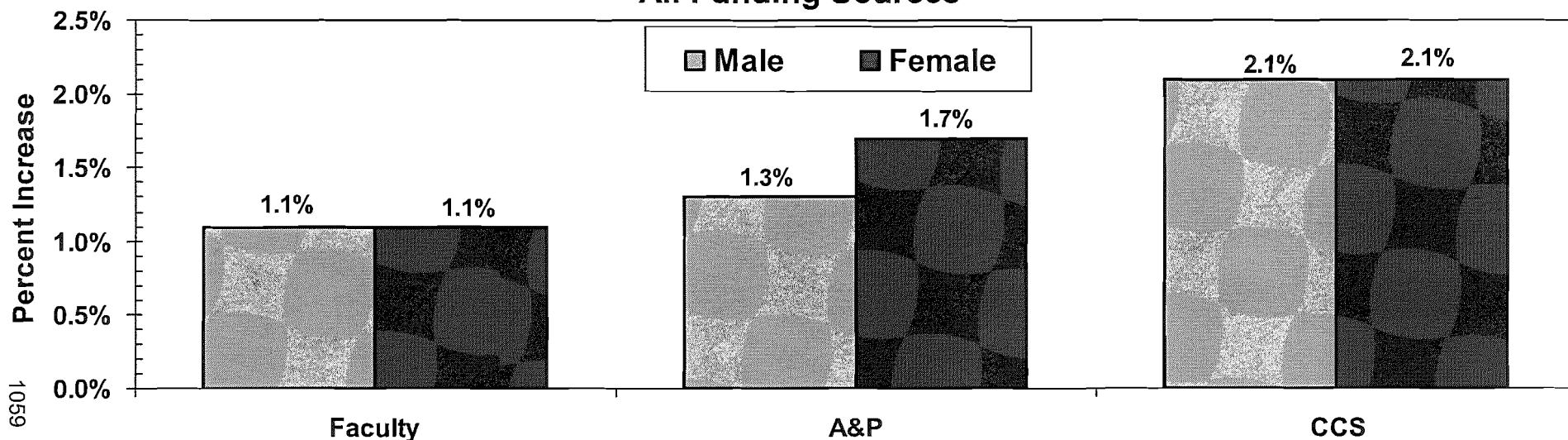

* Undisclosed ethnicity category excluded from report
 Excludes University Leaders, Administrators, bargaining unit members, Hospitals, term and temporary employees.



How do our benefits cost compare with other institutions?

- FY 2002-03 Benefit Premium Cost Comparison

The Ohio State University Premium Cost Comparison Among AAU Data Exchange Institutions Estimated for FY 2002-03

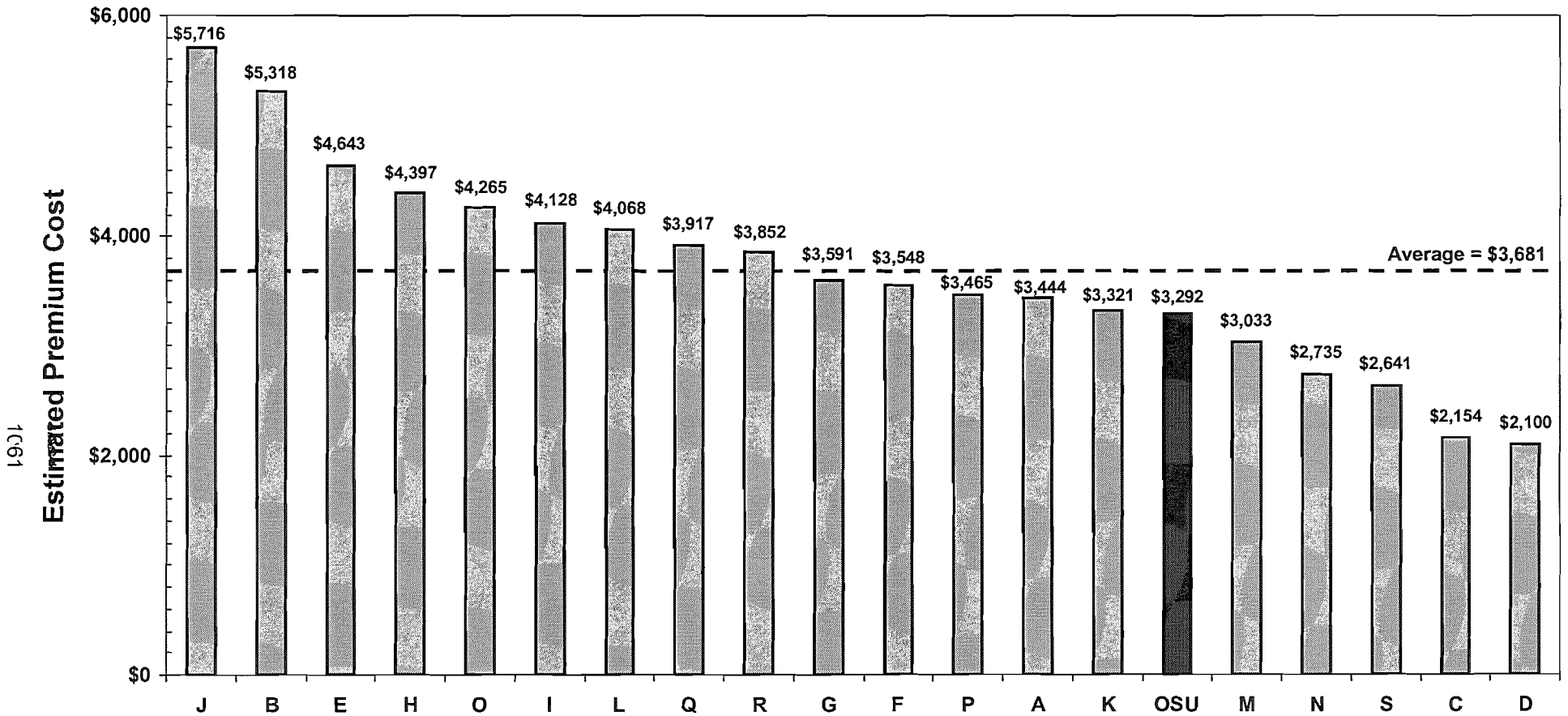

Source: AAUDE Survey of Benefits Programs, 2001-02
 Premium Cost (full funding cost) = Employer + Employee contributions
 Premium Cost reflects single coverage rate for medical coverage

Institutions include:

Arizona	Florida	Illinois	Indiana	Iowa	Kansas	Michigan
Michigan State	Minnesota	Missouri	Nebraska	Ohio State	Oregon	Penn State
Pittsburgh	Purdue	SUNY-Buffalo	Texas A&M	Texas	Wisconsin	



Summary

- On average, faculty and staff salaries are significantly behind market
 - ↓ Faculty salaries are behind market for 14 of the 16 colleges we have data for
 - ↓ Preliminary data suggest that staff salaries are behind market for all EEO categories (local and national)
- Our financial support for Graduate Associates is among the lowest for our benchmarks, particularly for health care sponsorship



What is the market outlook for raises for FY 2002-03?

- Competitive Salary Markets Outlook Fiscal Year 2002-03

Competitive Salary Markets Outlook FY 2002-03

IUC - Ohio - Higher Education	3.2% to 3.5%
Benchmark Institutions	3% to 5%
National - All employer groups	3.8% to 4%
Ohio - All employer groups	2.7% to 4.3%
Columbus, Ohio	3% to 4%
State Government of Ohio	4%
National - Higher Education & Non-Profits	0% to 5%



- FY 2002-03 Compensation Recommendations are scheduled for the May Board meeting

THE OHIO STATE UNIVERSITY
OFFICIAL PROCEEDINGS OF THE
ONE THOUSAND THREE HUNDRED AND EIGHTY-SECOND MEETING
OF THE BOARD OF TRUSTEES

Columbus, Ohio, May 3, 2002

The Board of Trustees met at its regular monthly meeting on Friday, May 3, 2002, at The Ohio State University Longaberger Alumni House, Columbus, Ohio, pursuant to adjournment.

**

**

**

Minutes of the last meeting were approved.

**

**

**

May 3, 2002 meeting, Board of Trustees

The Chairman, Mr. Brennan, called the meeting of the Board of Trustees to order on May 3, 2002, at 10:35 a.m. He requested the Secretary to call the roll.

Present: David L. Brennan, Chairman, James F. Patterson, Zuheir Sofia, Daniel M. Slane, Robert M. Duncan, Karen L. Hendricks, Dimon R. McFerson, Jo Ann Davidson, Kevin R. Filiatraut, and Joseph A. Shultz.

--0--

**ELECTION OF OFFICERS
BOARD OF TRUSTEES**

Resolution No. 2002-114

WHEREAS pursuant to paragraph (B) of rule 3335-1-02 of the Administrative Code, the officers of the Board are to be elected at the May meeting to take office immediately following adjournment of the meeting (May 3, 2002) and shall hold their office through the May 2003 meeting:

NOW THEREFORE

BE IT RESOLVED, That the following slate of officers for 2002-2003 be elected:

James F. Patterson, Chairman

Zuheir Sofia, Vice Chairman

William J. Napier, Secretary

James L. Nichols, Treasurer

Upon motion of Ms. Hendricks, seconded by Mr. McFerson, the Board of Trustees adopted the foregoing resolution by unanimous roll call vote, cast by Messrs. Brennan, Patterson, Sofia, Slane, McFerson, and Judge Duncan, Meses. Hendricks, and Davidson.

--0--

COMMITTEE APPOINTMENTS 2002-2003

Resolution No. 2002-115

BE IT RESOLVED, That the appointments to Committees and representatives to various Boards for 2002-2003 be approved as follows:

Academic Affairs Committee*

Daniel M. Slane, Chair
Robert M. Duncan, Vice Chair
Dimon R. McFerson
New Trustee
Joseph A. Shultz

Investments Committee*

Dimon R. McFerson, Chair
Karen L. Hendricks, Vice Chair
Zuheir Sofia
John Gerlach, Jr., Foundation Board
William Ingram III, Foundation Board

Fiscal Affairs Committee*

Zuheir Sofia, Chair
Tami Longaberger, Vice Chair
Karen L. Hendricks
Jo Ann Davidson
New Student Trustee

Agricultural Affairs Committee*

New Trustee, Chair
Fred L. Dailey, Vice Chair, Ex Officio
Jo Ann Davidson
Joseph A. Shultz
New Student Trustee

***Board Chair, Ex Officio member of all committees**

COMMITTEE APPOINTMENTS 2002-2003 (contd)

Academic Medical Center Strategic

Oversight Committee*

Daniel M. Slane, Chair
Robert M. Duncan
Zuheir Sofia
Dimon R. McFerson

Student Leadership Committee

James F. Patterson, Chair
Zuheir Sofia, Vice Chair
Tami Longaberger
Joseph A. Shultz
New Student Trustee
4 students (3 student government
leaders & chair of the Council on
Student Affairs)

Government Relations Committee*

Jo Ann Davidson, Chair
Tami Longaberger, Vice Chair
Dimon R. McFerson
New Trustee
Joseph A. Shultz
David L. Brennan
Michael F. Colley
William Blair
Stan Aronoff

Facilities Planning Committee*

Robert M. Duncan, Chair
Jo Ann Davidson, Vice Chair
Zuheir Sofia
Karen L. Hendricks
New Student Trustee

Outreach & Engagement Committee*

Karen L. Hendricks, Chair
Dimon R. McFerson, Vice Chair
Daniel M. Slane
New Trustee
New Student Trustee

Personnel Committee

James F. Patterson, Chair
Zuheir Sofia, Vice Chair
Tami Longaberger

Athletics Committee*

Tami Longaberger, Chair
Robert M. Duncan, Vice Chair
Dimon R. McFerson
New Trustee
Joseph A. Shultz
Big Ten Faculty Representative
Chair, Athletic Council
Academic Liaison to Athletics

Research Committee*

Tami Longaberger, Chair
Robert M. Duncan, Vice Chair
Karen L. Hendricks
New Trustee
New Student Trustee

Regional Campus Committee*

Karen L. Hendricks, Chair, -- Mansfield
Campus Board
Daniel M. Slane – Newark Campus Board
Dimon R. McFerson – Marion Campus Board
Jo Ann Davidson – Lima Campus Board
Joseph A. Shultz

**Arthur G. James Cancer Hospital and
Richard J. Solove Research Institute Bd**

Zuheir Sofia, Chair (2003)
Daniel M. Slane (2004)

University Hospitals Board

Zuheir Sofia
Daniel M. Slane

**University Managed Health Care System,
Board of Directors**

Robert M. Duncan (2 yr term exp. 2003)

Campus Partners Board

Jo Ann Davidson (2 yr term exp 2003)

**Ohio State University Affiliates, Inc. &
Affiliated Entities Committee**

James F. Patterson (1 year)
Zuheir Sofia (2 years)
Tami Longaberger (3 years)

Research Foundation Board of Directors

Karen L. Hendricks (2 yr term exp 2003)

**Science and Technology Campus
Board of Directors**

Robert M. Duncan (2 yr term exp 2003)

**University Foundation Ex Officio
Class of Directors**

Zuheir Sofia (1 year)
Tami Longaberger (2 years)
Daniel M. Slane (3 years)

Wexner Center Foundation Board

Leslie H. Wexner (2005)
Jo Ann Davidson** (2003)
**President's Appointment

***Board Chair, Ex Officio member of all
Committees**

COMMITTEE APPOINTMENTS 2002-2003 (contd)

Upon motion of Ms. Hendricks, seconded by Mrs. Davidson, the Board of Trustees adopted the foregoing resolution by unanimous voice vote.

--0--

CHAIRMAN'S REPORT

Mr. Brennan:

At the April meeting, we created a Presidential Search Committee to find our thirteenth president. The committee has begun its work, and we will begin this morning with an update from Jim Patterson, who chairs that group. Jim --

PRESIDENTIAL SEARCH COMMITTEE REPORT

Mr. Patterson:

Thank you, Mr. Chairman. The search committee has begun the process to find the next president of The Ohio State University. We have initiated a series of meetings with selected individuals and groups both inside and outside of the University to solicit input into the important traits that we should be looking for in selecting that right person. We have also met with the leaders of national educational organizations to obtain their input. At the conclusion of these meetings, we will bring forth a Presidential Profile that we will present to the Board. We are in the process and very near to a conclusion on engaging a search firm and will begin working with them in the very near future.

With the resignation of President William "Brit" Kirwan, The Ohio State University faces what will undoubtedly be its most important decision for years to come – the selection of a new leader to guide it into the next century. The University recognizes that this decision will be of tremendous importance to its students, faculty, staff and alumnae, and to the citizens of Ohio, and also that there is great interest in the search. In an effort to balance the special considerations applicable to a public institution with the realities of presidential employment, the University sets forth the following statement concerning its search process.

In designing that process, the University has taken as its central aim the goal of attracting the best possible candidates and obtaining the best possible person for that position. As is true in comparable private sector searches, that goal cannot be accomplished if the entire process and all of the candidates are subject to constant, intense public scrutiny. The persons who are given serious consideration, and the person who ultimately is selected, will in all likelihood already be prominent figures at prestigious institutions and will therefore have a great deal to lose if it becomes known too early that they are considering a new position. Many, if not most, of the candidates who will be considered will not have applied, but will rather have been nominated or sought out, and therefore cannot be said to have voluntarily consented to scrutiny, public or otherwise. Public disclosure of their names before screening and evaluation has occurred would be an unfair and potentially embarrassing invasion of their privacy.

Experience at other public institutions of higher education demonstrates that the most desirable candidates frequently withdraw from consideration, or simply refuse to be considered in the first instance, rather than place their existing positions at risk when they know that their names and their lives will become the subject of public speculation – thereby diminishing the size and quality of the candidate pool. It is increasingly apparent that public and private universities are competing for the most accomplished leaders, putting the publics at a competitive disadvantage in the search and screening process. The future of the

PRESIDENTIAL SEARCH COMMITTEE REPORT (contd)

Mr. Patterson: (contd)

University, in a very real sense, thus rests on an appropriate degree of confidentiality with respect to the search.

Assuredly, the University does desire to conduct its search in as public a manner, and, more importantly, with as much public input, as is possible without compromising our ultimate goal of finding the very best person for this University in this time in the University's life. Accordingly, the University: 1) has appointed a search committee consisting of 18 members who are broadly representative of interested constituencies to lead the search; 2) the University will retain a nationally recognized, highly experienced search firm to assist the search committee in identifying and screening candidates; 3) the University will advertise the position widely and seek both applications and nominations; 4) the University has established a web page with information about the position and the search, including a link through which the public can submit nominations and comments electronically -- and that is up and running at this time; 5) the University will publicize a P.O. Box and telephone number where public input and comments may be directed; 6) the University will hold open forums -- one open forum was held this past Monday, and another will be held this coming Monday, May 6, from 4-5 pm in the Ohio Union Conference Theatre -- where the public will have an opportunity to meet with members of the Search Committee and provide input on the Position Profile; and 7) the Search Committee will provide reports on the progress of the search at all meetings of the University's Board of Trustees until the search has been completed.

The exercise of discretion and understanding -- both within and outside the University community -- while the search progresses will greatly enhance our likelihood of success. The reward will be the attraction of the very best individual to be the thirteenth president of The Ohio State University.

CHAIRMAN'S REPORT (contd)

Mr. Brennan: (contd)

Over the years, this Board has been well served by its student trustees and that is especially true in the case of Kevin Filiatraut, who today is attending, as I am, his final Board meeting. I speak for all those who have served with Kevin when I say that his intelligent, reasoned, informed and thoughtful approach has been of great benefit to our deliberations and to the University.

Kevin, you are an excellent student trustee. We thank you for your many contributions and wish you every success in the future. We would like to present you with this plaque to express our appreciation of your work as a student trustee.

Next, I want to comment upon one item on this morning's agenda that to me carries special significance. That is the resolution to name the Botany and Zoology Building, at 1735 Neil Avenue, for Ohio State's tenth president, Ed Jennings.

Those who were not here during the Jennings presidency, which lasted from 1981 until 1990, may not be fully aware of his many contributions. Considered broadly, his initiatives formed the foundation for today's march toward great university status and academic excellence. His legacy includes: our selective investment strategy; competitive admissions; restructuring and updating the

CHAIRMAN'S REPORT (contd)

Mr. Brennan: (contd)

undergraduate curriculum; improved compensation for faculty; strengthening the honors program; initiating the Young Scholars program, as part of his emphasis on affirmative action; completing our first comprehensive private capital fundraising campaign, which went way over goal and raised more than \$450 million; and creating the Research and Technology Park that is now SciTech.

Also during his tenure, the University opened: the Wexner Center for the Arts; The Arthur G. James Cancer Hospital and Richard J. Solove Research Institute; the Woody Hayes Athletic Center; the Frank Hale Black Cultural Center; and the Ohio Supercomputer Center. I should add also that he faced an extremely grave crisis in state funding and provided exceptional leadership in steering us through that difficult period.

More recently, he has been an excellent and very popular member of the faculty in the Fisher College of Business. He also continues to serve his community and this University, currently chairing a committee to review the organization of the Colleges of Arts and Sciences.

Ohio State has been fortunate to enjoy the firm, creative leadership of many excellent presidents, including our incumbent. Ed Jennings was one of the very best, and I personally am delighted that he is being recognized through our action today. Ed is with us this morning and I would like for him to stand and be recognized, and say a few words.

Dr. Edward H. Jennings:

Thank you, Mr. Chairman. I am not sure who that guy is that you are talking about, but I really appreciate those kind words. It is a great honor to be recognized on campus and it is especially fitting for me that the naming is an academic building in the heart of the campus -- even though you are going to gut it fairly shortly, and that is what some said they should have done to me!

When you are in a position of leadership you make a variety of decisions, and those decisions typically have long-range consequences that are very uncertain. So your recognition is a double honor to recognize that some of the decisions and strategies we developed in the 1980s are bearing fruit today and continue to bear fruit. It is enormously gratifying to me to see the improvements in the freshmen class, and when you mentioned that we raised \$450 million -- Jerry May thinks that is a pittance today. Those decisions, made under uncertainty, being recognized now is very gratifying. I'm also enormously gratified that you as a Board, Brit Kirwan, and Gordon Gee before him, continue the quality emphasis at Ohio State. This is indeed a great, great University, but we can always get better. Indeed, no matter what our quality accomplishments might be, we can always get better.

And, finally, as you honor me, you really honor a lot of people. No executive can function very well without the support of an enormous number of people and, by gosh, we have a lot of good people here at Ohio State. I won't take up your time, Mr. Chairman, naming them, but they range from a man in the Physical Plant named Eric Esswein, to one of my Board members, Jack Havens -- and everyone in between -- people who supported me during those nine years.

Mr. Chairman and members of the Board, thank you very much. It is indeed a great honor for me; I appreciate it and my family appreciates it. Thank you.

CHAIRMAN'S REPORT (contd)

Mr. Brennan:

Thank you, Professor Jennings.

There is one final item I would like to mention. Each month our President reports to us on the University's progress in achieving academic excellence. Each month he singles out a few faculty, students or staff who, as we say, are "Doing Something Great." Today is our chance to turn the tables and congratulate him on a truly magnificent accomplishment – and I'm not talking about that job in Maryland.

As you may know, just this week President Kirwan was elected to the American Academy of Arts and Sciences. Election to America's preeminent learned society – which was founded by such scholar-patriots as John Adams and John Hancock – is a great honor and magnificent tribute to a very deserving man. We are so glad that you achieved this distinction as a Buckeye!

--0--

PRESIDENT'S REPORT

President William E. Kirwan:

Thank you, Mr. Chairman, for those very nice words.

Members of the Board of Trustees, I would first like to say that I whole-heartedly and enthusiastically endorse Chairman Brennan's appraisal of the tremendous impact that Ed Jennings has had on The Ohio State University. Indeed, much of the success we have enjoyed during my four years as president has been built on the foundation of academic excellence that Ed Jennings established in the 1980s. Ed Jennings' administration laid the groundwork for the Academic Plan that we are now implementing. And it is a testament to Ed that the drive for academic excellence that he began at Ohio State some 20 years ago has continued and intensified throughout two subsequent administrations. Certainly, The Ohio State University owes a tremendous debt of gratitude to Ed Jennings.

In our continuing drive for academic excellence, I am very pleased to report to the Board three key groundbreaking events happening within a one-month period. First, we broke ground in April for the new Knowlton School of Architecture. Thanks to the generosity of Dutch Knowlton and many other loyal Ohio State supporters, all of the School's students and faculty will be under one roof for the first time in 50 years. And not only will they be under one roof, they will be working and learning in the nation's premier architecture facility. The presence of the Knowlton School of Architecture directly across the street from the Fisher College of Business will establish a dynamic tone of innovation, academic excellence, and unparalleled opportunities for interdisciplinary study by our students and faculty.

Later this month, we will also break ground for a new physics building that will substantially enhance the research and learning capabilities of our faculty and students. The new \$50 million facility will be located at the site of the old Welding Engineering building, directly northwest of Smith Laboratory. With state-of-the-art laboratories and facilities that blend teaching and research, the new building will provide an excellent home for our physics program, which is one of our Selective Investment programs and which is on a rapid rise to the top tier of physics departments in America.

PRESIDENT'S REPORT (contd)

President Kirwan: (contd)

Also this month, we will break ground for the new Richard M. Ross Heart Hospital. The Ross Heart Hospital will work in tandem with Ohio State's new Dorothy M. Davis Heart and Lung Institute, and these two facilities will form a comprehensive heart center that will help make Ohio State a national leader in heart research and patient care.

We also reached another milestone in our Gateway Project to transform the south entrance to our campus and to revitalize our entire neighborhood. On Wednesday, Mayor Coleman, Undergraduate Student Government President Eddie Pauline, and I donned hard hats and released a wrecking ball to begin demolition along two blocks of High Street – if you have never done that I strongly recommend it, it is a very therapeutic activity -- where we will begin construction of the University Gateway Center this summer.

The Gateway Project represents one of the nation's premier examples of successful collaboration among a university, city and state government, and the private sector. I think it is worth noting that this is a project that when you look at all of the investments from the private sector, the city, the state, and the University it is about \$100 million. It is one of the most significant urban redevelopment projects underway in our country and the fact that so many different entities have been pulled together to make this work should be a source of pride to all of us.

Our excellent working relationship with the City of Columbus also has continued with our extensive involvement in planning for this month's Heritage Festival. We are also working closely with the city to prevent further disturbances in the neighborhood east of High Street this spring. Following the disgraceful behavior of a small percentage of our students last month, we took swift action to punish those involved and we have worked extensively with the city and with student groups to keep these disturbances from happening in the future. I would like to extend my thanks to Mayor Coleman, Safety Director Mitchell Brown, the Columbus and University Police, Eddie Pauline and the Undergraduate Student Government, and Bill Hall and the Office of Student Affairs for their exceptional efforts in this regard.

During the past month, several Ohio State faculty have received impressive national and international recognition. For instance, Nicholas Howe, professor of English and director of the Center for Medieval and Renaissance Studies, received a highly prestigious Guggenheim Fellowship to study the cultural geography of Anglo-Saxon England. More than 2,800 scholars, artists, and scientists applied for the 184 Guggenheims that were awarded this year.

It seems that almost every month we hear of another international prize awarded to Lonnie Thompson, our world-renowned expert on global climate change. Last month was no exception. Professor Thompson will receive the 2002 Dr. A.H. Heineken Prize, given annually by the royal Netherlands Academy of Arts and Sciences. The prize comes with a \$150,000 award. Professor Thompson and several colleagues are now in Alaska drilling for a record of ancient weather trapped inside ice from Alaskan glaciers that could date back thousands of years.

Another major award, the S.T. Li Prize for Achievements in Science and Technology was awarded to Leo Paquette, Distinguished University Professor of Chemistry and a member of the National Academy of Sciences. Also, yesterday Janet Hickman, associate professor of Teaching and Learning in the College of Education, received the Arbuthnot Award from the International Reading

PRESIDENT'S REPORT (contd)

President Kirwan: (contd)

Association. That award recognizes the nation's outstanding college teacher of reading and children's literature.

Before I close my comments, I would also like to mention two new developments to further enhance diversity at Ohio State. And since Carole Anderson will soon be presenting the Diversity Council's report to you, I'd also like to reflect briefly on the overall progress we have made at Ohio State in regard to diversity issues. These two new initiatives, in addition to strengthening our commitment to diversity, also demonstrate how the spirit of the Buckeye football program encourages our former players to give back to the University.

First, former All-American Shawn Springs, who now plays with the NFL's Seattle Seahawks, made a \$100,000 gift to create the Shawn Springs/Majority of One Post-Graduate Scholarship. Shawn was the first president of the Majority of One Program here at Ohio State. This program addresses the emotional, social, intellectual, and physical needs of minority-student athletes. Another former Ohio State football player who played in the NFL, Todd Bell, is now back on campus and has teamed with Vice Provost for Minority Affairs Mac Stewart to develop an innovative mentoring program to increase retention rates for African American males across the University. The involvement of these two great Buckeyes speaks volumes about their commitment to Ohio State and will have a significant impact on our students.

Back in January of 1998, during the press conference in which I was introduced as the new president of The Ohio State University, diversity was one of the four values I said I would stress during my tenure as president. I hoped to work with the University community to make Ohio State a welcoming environment where we celebrate diversity and where all of our students, faculty and staff feel inspired and empowered to fulfill their potential. I hoped that we could take advantage of the great learning opportunities provided by a diverse and tolerant culture.

Over the past four years, I have been very pleased with the way the University community has responded to this challenge. And I would like to take this opportunity to formally thank everyone who has supported our efforts so enthusiastically and diligently. We created a Diversity Action Plan with clear goals and real accountability. We established the Diversity Council, the Women's Place, the President's Council on Women's Issues, the Institute for the Study of Race and Ethnicity in the Americas – and Board members had the chance to meet the distinguished new director of that Institute, John Powell, earlier – the Multi-Cultural Center, the President and Provost's Diversity Lecture Series, and a variety of other structures to institutionalize our commitment to diversity. Certainly, we have a long way to go, but the foundation is in place, and I feel very proud about where Ohio State is headed in terms of its diversity goals.

Finally, I would like to take a moment to thank our two trustees who are participating in their final meeting today. Kevin Filiatraut, as David Brennan said, you have been an excellent student trustee. All of us have been truly impressed by your contributions to the work of the Board. Your thoughtful insights and exceptional diligence are traits that will serve you very well in your legal career. On behalf of the entire University community, I want to thank you for your service and all of us wish you the very best in what we know will be a fabulously successful career.

Kevin, would you like to make a few comments?

PRESIDENT'S REPORT (contd)

Mr. Filiatraut:

Thank you. First, I would like to thank Dr. Kirwan and Chairman Brennan, for the opportunity to speak. Let me say, Mr. Chairman, that if imitation is the finest form of flattery, you need look no further than this Board to see your effect on this great University. And I'm not talking about the "White Hats"!

I would just like to say that it has been an honor to serve the people of Ohio as a Student Trustee. It is a learning experience like no other. I'm very grateful to all of those who thought I was competent to do the job and who later entrusted me with it.

I thank first, the Board Office -- Maureen, Lucy, Suzanne, and Holly -- they are the life line of the Board. There is no question about that, they have saved me a number of times. I thank, finally, all of the Board members, generally, for showing what it means to be entrusted to govern and, specifically, for giving me -- and all student trustees before and after -- the respect that we need in order to do our jobs for the people of Ohio. The way The Ohio State University Board of Trustees treats its student trustees is an example for all of Ohio. Thank you.

President Kirwan:

Thank you, Kevin.

Finally, I want to thank our Chairman for his nine years of outstanding service to this Board and to The Ohio State University. David Brennan – with his white-hat idealism – has a passion for excellence. David, you have been a visionary leader for education in Ohio for many years. And over the past years, your vision and your commitment to excellence has helped guide us to develop and implement an Academic Plan that will enable Ohio State to enter the ranks of the nation's truly great universities.

Last night we had a chance to celebrate your incredible service as a Trustee. I won't repeat the many glowing things said about you at that occasion. Let me simply say, at this time, that your service on the Board over the past nine years and your leadership in raising the aspirations and the standards of the University have had an enormous impact. We are a better University because of you. I know Ohio State will continue to benefit from your wisdom and leadership in the years ahead.

From a personal standpoint, I thank you for the privilege of working with you. No university president could have had a more supportive board chair than I have enjoyed over this past year. I will always treasure our wonderful friendship and your unstinting support. On behalf of the University community, I thank you for nine years of phenomenal service and inspired leadership. Thank you very much.

Mr. Brennan:

Thank you.

President Kirwan:

Mr. Chairman and members of the Board, that completes my report.

--0--

DIVERSITY REPORT

President William E. Kirwan:

At this time, I would like to introduce Carole Anderson, vice provost for Academic Administration and chair of the Diversity Council, who will present the University's Diversity Report.

Dr. Carole A. Anderson: [PowerPoint Presentation]

Thank you, President Kirwan. I'm pleased to be here and present the progress report on the Diversity Action Plan for 2000-2001. The new report will be done sometime this spring and, hopefully, we'll be able to bring that to the Board next year.

A little bit about the history of the Diversity Action Plan: it was adopted in October 2000 and that fall the deans and vice presidents were requested to write unit diversity plans. A Diversity Council was recommended, and the Council recommended standardized templates be used in future reports, which was on the basis of the analysis of the fall reports. We received different information from different units and so we thought it would be more useful to have standardized information. Then in the Spring 2001, the deans and vice presidents wrote the results of their diversity plan. The Council on Diversity analyzed those plans and in doing so, we thought it's important to think about the contexts in which they happened.

The first point to be made is that we realized this was the first year of the implementation of the plan and that measurable change would take several years to be seen, and that identifying success was more important than identifying shortcomings in the progress that was being made. But we also realized that not all members of the University community are equally committed to the goals of the Diversity Action Plan.

Some of the highlights from the plan are that diversity is highly visible on campus, in evidence of such things as the "Can We Talk?" Program, the Diversity Lecture Series, and the other things that President Kirwan mentioned a few minutes ago. Clearly, the president and provost have consistently stressed the importance of diversity at every opportunity they have had and they have made it a very visible topic.

The Multicultural Center opened and several college units made administrative appointments to implement the diversity agenda in their units. The Office of Student Affairs sponsored, and is still sponsoring, several programs that are aimed at increasing the understanding of diversity among the student body. The president and provost met with the Gay, Lesbian, Bisexual, and Transgender representatives on two occasions, and the Office of University Relations has provided excellent coverage of all diversity events. Having said all of that, however, the Council on Diversity believes there is still a long way to go.

Some of the results of the first year are that the faculty profile looks like this and it is a slight gain over what was in 1999, but not a huge gain. Some of the colleges have made substantial progress, for example: Humanities, Law, Social and Behavioral Sciences, Arts, and Business. But retention of women and minority faculty continues to be an issue.

In terms of the student profile -- you can see the make up of the undergraduate student body -- first year retention rates are up. For example, last fall the percentage of African Americans in the freshman class was 9.9 percent. Among the professional students, there were slight changes. The numbers of African American students increased, Hispanics and Asian students decreased, but very

DIVERSITY REPORT (contd)

Dr. Anderson: (contd)

slightly, so there really wasn't very much change. And among graduate students there were slight decreases in enrollment of all groups.

The summary of that was that a good start has been made in addressing diversity goals. We concluded that dedicated attention to diversity does bring results and that some of the units have been paying attention to it long before the Diversity Action Plan and they're the ones that have made more progress. The quality of the reports from the different units were uneven and in the opinion of the Council, reflected varying degrees of commitment to the goals of the Diversity Action Plan. Few of the units addressed issues related to Gay, Lesbian, Bisexual, and Transgender populations or issues of work-life balance, and that some of the areas in the Diversity Action Plan have yet to be addressed, for example, providing seed money for research grants establishing a Minority Alumni Council, and a comprehensive development plan.

Some of the selective recommendations based on the results of that was that there needed to be a centralized training program for the University's leadership, deans, vice presidents, and department chairs to heighten the awareness of the need for enhancing diversity and ways that that could be done. There needs to be an increased use of targeted faculty searches and the units that use that particular mechanism were very successful in recruiting minority faculty particularly. And that full domestic partner benefits should be extended for faculty, staff, and students. The Council believes that we are leaving some talent on the table because we don't have those at our University.

The Council also recommended that we work to create an institutional norm that supports so-called family-friendly environments, ensuring that all employees are comfortable utilizing the existing benefits. We do have several benefits that are family-friendly, but it appears that some people aren't equally comfortable in requesting those.

Another recommendation was to provide effective support for at-risk students. You just heard President Kirwan talk about a new program aimed at the retention of African American males. They do have the lowest retention rate in the University, so that is a very important initiative. And all units need to feature diversity at public events.

The next step for the Diversity Council is the analysis of the 2001-2002 plan. That is in progress right now in an annual report. I will say that we see continuing progress being made this past year by almost all units and that is encouraging, and, hopefully, we'll continue to move along and make continual progress.

Thank you very much. I'd be happy to answer any questions that anyone might have.

Mr. Brennan:

Any questions? Thank you, Dr. Anderson.

--0--

STUDENT RECOGNITION AWARD

Mr. Shultz:

Ladies and gentlemen, periodically the Board of Trustees has the opportunity to recognize outstanding students who are leaders both in and out of the classroom. Nominated by Dr. Bobby Moser, dean of the College of Food, Agricultural, and Environmental Sciences, today we are proud to recognize Emily Buxton Adams, an undergraduate student majoring in food science.

Emily exemplifies what it means to be a student at The Ohio State University through her rigorous course work, her leadership on campus, and her outstanding honors research project. Also, with her in the audience today is her good friend and mentor, Dr. Ray Miller, assistant dean of the College of Food, Agricultural, and Environmental Sciences.

Emily's honors research project has focused on fat determination in bovine and human milk using crematoric procedure and tri-glyceride analysis. Now as Emily explained to me a little more simply, her honors project is a small piece of a much larger research project going on in Food Science, which looks at the effects of pigments, the natural substances found in milk, which can help fight cancer. This research is being done in the Department of Food Science in conjunction with The James Cancer Hospital.

Involvement in campus activities has also been one of Emily's priorities. As president of the Agricultural and Natural Resources College Council, she has invigorated other student organizations with energy and leadership skills. One of her major accomplishments has been to design and host a leadership night, which over sixty students from the College of Food, Agricultural, and Environmental Sciences participated. Emily has also taken her classroom learning to a new level by competing on the OSU Dairy Products Evaluation Team, which competed throughout the United States.

Emily has also shown her dedication to serving others by taking a one-year leave of absence from The Ohio State University to serve as the National Vice President of the Future Farmers of America. During this year of voluntary service, Emily traveled to over thirty states and Japan, developing the leadership skills of high school students.

After graduation in just a few weeks, she will begin work on her master's degree in the Food Science Department here at The Ohio State University. She will continue to focus her course work on research on the functional properties of various dairy components.

Emily, on behalf of President Kirwan and the entire Board of Trustees, I want to wish you the best as you pursue your goals here at Ohio State as I present you with a Student Recognition Award.

Ms. Emily Buxton Adams:

Thank you very much for such an honor. There are many deserving students within the College of Food, Agricultural, and Environmental Sciences that could easily be sitting here today as I am, and I have the pleasure of working with them. We encourage each other to help build our community, college, and overall our University. So, I'd like to accept this award on behalf of them as well and share this with them.

I think that the first time I said I was coming to Ohio State I was a first or second grader. I've always known that I was going to be a Buckeye. When people would ask me what I was going to be when I grew up, I didn't have a clue. I

STUDENT RECOGNITION AWARD (contd)

Ms. Buxton Adams: (contd)

never knew exactly what to say, but I knew that if I came to Ohio State, no matter what I wanted to be, there would be faculty, staff, and supporters here to help me. With people like Dr. Miller, Dr. Moser, and my friend Joe, we help each other. I would like to thank you for this and thank you for helping me be the best Buckeye that I could be.

--0--

CONSENT AGENDA

President William E. Kirwan:

We have 16 resolutions on the Consent Agenda today and I would like to ask that #9 be held for a separate vote. Unless there are any objections, I would like to recommend the remaining 15 resolutions on the Consent Agenda to the Board:

AMENDMENTS/WAIVER -- RULES OF THE UNIVERSITY FACULTY

Resolution No. 2002-116

Synopsis: Approval of the following amendments to and a waiver of the *Rules of the University Faculty* are recommended.

WHEREAS the University Senate pursuant to rule 3335-1-09 of the Administrative Code is authorized to recommend through the President to the Board of Trustees the adoption of amendments to the *Rules of the University Faculty* as approved by the University Senate; and

WHEREAS the proposed changes in the *Rules of the University Faculty* were approved by the University Senate on April 11, 2002:

Amended Rule

3335-5-4814 Research committee.

(A) Membership.

The research committee shall consist of twenty-six members.

(1) Sixteen faculty.

Ten regular faculty to be determined by the established procedures of the council on research and graduate studies. Faculty must be members of the council on research and graduate studies and represent the ten areas of the graduate school. The term of service is ~~two~~ four years.

(b) Six regular faculty selected by the faculty council. Of these six, one member must serve on a regional campus and no more than one member may be from any individual college. The term of service is ~~three~~ four years.

Balance unchanged.

and

AMENDMENTS/WAIVER -- RULES OF THE UNIVERSITY FACULTY (contd)

WHEREAS the Board seeks to waive rule 3335-9-11 of the Administrative Code, which precludes a faculty member from holding a faculty appointment in the college in which they are pursuing a degree, to allow Professor Mauro Ferrari, who holds joint faculty appointments in the Colleges of Engineering and the College of Medicine and Public Health, to enter medical school to obtain his M.D. degree:

NOW THEREFORE

BE IT RESOLVED, That the foregoing amendments to the *Rules of the University Faculty* be adopted as recommended by the University Senate, and that rule 3335-9-11 of the Administrative Code be waived for Mauro Ferrari, effective immediately.

WAIVER AND NAMING OF BUILDING

Resolution No. 2002-117

Synopsis: Approval of the Waiver of Paragraph (F) of Bylaw 3335-1-08 of Administrative Code and Naming of the Botany and Zoology Building, located at 1735 Neil Avenue, to honor Edward H. Jennings, president emeritus of The Ohio State University and professor of Finance, is proposed.

WHEREAS the Board of Trustees of The Ohio State University, did on January 9, 1976, amend paragraph (F) of bylaw 3335-1-08 of the Administrative Code to state that "buildings and structures shall not be named for any person who is an officer or employee of the University or the State of Ohio, but may be named for a person who has been retired or has otherwise left such a position for a minimum of three years"; and

WHEREAS the Board of Trustees has authority in naming of all buildings and structures at The Ohio State University, as set forth in paragraph (F) of rule 3335-1-08 of the Administrative Code; and

WHEREAS it is recommended that the Botany and Zoology Building, located at 1735 Neil Avenue, Columbus, Ohio, be named in honor of Edward H. Jennings, who served as the tenth president of the University from 1981 to 1990, and professor of Finance until his retirement on March 31, 2002; and

WHEREAS under his outstanding leadership the University made great strides toward excellence, including moving to selective admissions, and restructuring and updating the undergraduate curriculum; and

WHEREAS The Ohio State University launched an important initiative to attract more minority students and faculty, to recognize and encourage more University affirmative action programs, and to establish the Young Scholars Program across Ohio for promising junior and senior high school minority students; and

WHEREAS during his presidency The Ohio State University completed its first private fundraising comprehensive capital campaign which raised \$451 million, well above the goal of \$350 million; and

WHEREAS several remarkable campus landmarks – the Wexner Center for the Arts, The Arthur G. James Cancer Hospital and Richard J. Solove Research Institute, the Woody Hayes Athletic Center, and the Frank Hale Black Cultural Center – were built during his tenure; and

PERSONNEL ACTIONS (contd)

Appointments (contd)

Name: LAWRENCE H. NEWCOMB
Title: Professor (The Sanford G. Price and Isabell P. Barbee Chair in Teaching, Advising, and Learning)
College: Food, Agricultural, and Environmental Sciences
Term: June 1, 2002 through May 31, 2007

Name: DAVID E. SCHULLER
Title: Professor (The Max Morehouse Chair in Cancer Research)
College: Medicine and Public Health
Term: May 1, 2002 through June 30, 2006

Promotions

Name: MAURO FERRARI
Title: Associate Vice President for Technology and Commercialization
Office: Health Sciences
Effective: May 3, 2002
Concurrent Positions: Director and Professor (The Edgar C. Hendrickson Designated Chair in Biomedical Engineering), Departments of Biomedical Engineering, Mechanical Engineering, and Internal Medicine

Name: JOHN R. MEYER
Title: Associate Vice President
Office: University Development
Effective: April 1, 2002
Present Position: Assistant Vice President, University Development

Reappointments

Name: MICHAEL S. BEATTIE
Title: Professor (The Doctor John D. and E. Olive Brumbaugh Chair in Brain Research and Teaching)
College: Medicine and Public Health
Term: July 1, 2002 through June 30, 2006

Name: DONNA A. CANIANO
Title: Professor (H. William Clatworthy, Jr., Professorship in Pediatric Surgery)
College: Medicine and Public Health
Term: July 1, 2002 through June 30, 2006

Name: M. RONALD GLASER
Title: Professor (The Gilbert and Kathryn Mitchell Chair)
College: Medicine and Public Health
Term: July 1, 2002 through June 30, 2006

Name: YANG LIU
Title: Professor (The Ralph W. and Helen Kurtz Chair in Pathology)
College: Medicine and Public Health
Term: July 1, 2002 through June 30, 2006

Name: JOHN M. STANG
Title: Associate Professor (The Harry C. and Mary Elizabeth Powelson Professorship in Medicine)
College: Medicine and Public Health
Term: July 1, 2002 through June 30, 2006

PERSONNEL ACTIONS (contd)

Appointment of Chairperson

October 1, 2002 through June 30, 2006

Women's Studies

Linda M. Mizejewski

Leaves of Absence Without Salary

LISA Y. FLORES, Assistant Professor, Department of Psychology, effective Autumn Quarter 2002, Winter Quarter and Spring Quarter 2003, to collaborate on research at the University of Missouri in Columbia.

ANDREA K. NEWLYN, Assistant Professor, Department of English (Lima Campus), effective April 1, 2002, through March 31, 2003, for personal reasons.

Professional Improvement Leaves

ROBERT C. MACCALLUM, Professor, Department of Psychology, effective Autumn Quarter 2002, Winter Quarter and Spring Quarter 2003.

SHARON L. DAVIES, Associate Professor, Moritz College of Law, effective August 19, 2002, through May 9, 2003.

HELEN M. MARKS, Associate Professor, Department of Educational Policy and Leadership, effective Autumn Quarter 2002, Winter Quarter and Spring Quarter 2003.

Professional Improvement Leave—Cancellation

WILLIAM I. AUSICH, Professor, Department of Geological Sciences, effective Autumn Quarter 2002, Winter Quarter and Spring Quarter 2003.

Professional Improvement Leave—Change in Dates

GREGORY JUSDANIS, Professor, Department of Greek and Latin, change leave from Autumn Quarter 2002, Winter Quarter and Spring Quarter 2003, to Spring Quarter 2003.

Emeritus Titles

STIG M. BERGSTROM, Department of Geological Sciences, with the title Professor Emeritus, effective July 1, 2002.

MOON S. CHEN, JR., School of Public Health, with the title Professor Emeritus, effective July 1, 2002.

GUNTER FAURE, Department of Geological Sciences, with the title Professor Emeritus, effective July 1, 2002.

MUTTAIYA SUNDARALINGAM, Department of Chemistry, with the title Professor Emeritus, effective May 1, 2002.

RODNEY T. TETTENHORST, Department of Geological Sciences, with the title Professor Emeritus, effective July 1, 2002.

CHARLES H. BELL, Ohio State University Extension, with the title Associate Professor Emeritus, effective May 1, 2002.

WILLIAM E. HENDERSON, Ohio State University Extension, with the title Associate Professor Emeritus, effective May 1, 2002.

PERSONNEL ACTIONS (contd)

Emeritus Titles (contd)

JIM G. POLSON, Ohio State University Extension, with the title Associate Professor Emeritus, effective May 1, 2002.

DENNIS K. BAKER, Ohio State University Extension, with the title Assistant Professor Emeritus, effective July 1, 2002.

RESOLUTIONS IN MEMORIAMS

Resolution No. 2002-120

Synopsis: Approval of Resolutions in Memoriam are proposed.

RESOLVED, That the Board adopt the following Resolutions in Memoriam and that the President be requested to convey a copy to the families of the deceased.

Carolyn North Burnett

The Board of Trustees of The Ohio State University expresses its sorrow upon the death on March 5, 2002, of Carolyn North Burnett, Associate Professor Emeritus in the School of Allied Medical Professions.

Professor Burnett held a Bachelor of Science degree from Iowa State University and a Master of Science degree from the University of Illinois Professional Colleges. She taught physical therapy at Duke University Medical Center before coming to The Ohio State University in 1964. Professor Burnett was a professor of physical therapy in the School of Allied Medical Professions and taught in the School for 28 years. She coordinated the graduate student activities with foresight, which led to a progressive and dynamic program in physical therapy. Professor Burnett served as curriculum director of the School for five years and as an assistant director for one year. The development and evolvement of course materials related to geriatrics, documentation, problem solving, and ethics was accomplished through her interest and diligent work.

Professor Burnett's extensive voluntary service with the Commission on Interprofessional Education and Practice provided major visibility for the School while supporting an interdisciplinary focus on education. A major contribution was her dedication to developing expertise in geriatrics and serving as a School-wide resource in geriatrics and gerontology. Her major research interest was developmental kinesiology and exercise physiology. Her scholarship focused on gait analysis and development in children.

Professor Burnett served her profession at the highest level. She was an active member of the American Physical Therapy Association for 46 years, having served both the national association and the Ohio Chapter.

An active member of the University community, Carolyn Burnett served on numerous school, college and University committees. The value of her mentoring, friendship, and guidance to faculty and students, especially graduate students, was enormous.

On behalf of the University community, the Board of Trustees expresses to the family of Professor Carolyn North Burnett its deepest sympathy and sense of understanding of their loss. It was directed that this resolution be inscribed upon the minutes of the Board of Trustees and that a copy be tendered to her family as an expression of the Board's heartfelt sympathy.

RESOLUTIONS IN MEMORIAMs (contd)

John E. Horrocks

The Board of Trustees of The Ohio State University expresses its sorrow upon the death on February 7, 2002, of John E. Horrocks, Professor Emeritus in the Department of Psychology.

Professor Horrocks received his Ph.D. degree from Syracuse University and took his first academic position here at The Ohio State University in 1945, where he remained until he retired in 1983. During his 39 years at OSU, Professor Horrocks advised a total of 89 Ph.D. students. He also built a developmental program which included specialty areas in child-clinical psychology, mental retardation and developmental disabilities, measurement, and educational psychology, as well as a core program in developmental psychology that had faculty who were experts in all major phases of the life span.

Professor Horrocks authored or co-authored six books, including a theoretical book on the nature of self, and textbooks in several areas. There were four editions of his textbook on adolescence, one of the most comprehensive and widely-used textbooks in that field in modern times. His books were all originally written in longhand, in impeccable script.

John Horrocks was also well known for his service contributions to the field of psychology, the nation, the University, and the Columbus community. He was the main editor for three psychology journals and served on the editorial boards of other journals as well. In one journal alone, approximately 2,000 articles were published under his editorship. During the Korean war, he wrote 32 technical reports as he engaged in research that was used for training of anti-aircraft gunners. He was also active in governance in the University community, chairing the Athletic Council, and he was a patron of the arts in the local community.

On October 18, 2001, Professor Horrocks was presented an award for "Lifetime Achievement by a Psychologist" for his contributions to the field and profession.

On behalf of the University community, the Board of Trustees expresses to the family of Professor John E. Horrocks its deepest sympathy and sense of understanding of their loss. It was directed that this resolution be inscribed upon the minutes of the Board of Trustees and that a copy be tendered to his family as an expression of the Board's heartfelt sympathy.

Walter L. Slatter

The Board of Trustees of The Ohio State University expresses its sorrow upon the death on March 10, 2002, of Dr. Walter L. Slatter, Professor Emeritus in the Department of Food Science and Technology.

Dr. Slatter held a Bachelor of Science degree in dairy technology from The Ohio State University, a Master of Science degree in dairy technology from Iowa State University, and a Doctor of Philosophy degree in dairy technology from the University of Minnesota. He joined the faculty of the Department of Dairy Technology at The Ohio State University in 1936, where he served for 40 years in teaching, research, and public service.

His areas of expertise were dairy microbiology, dairy proteins, the technology of butter and cheese and product grades, standards, and quality evaluation. During his career he accepted two foreign assignments, one of which was of a four-year duration with The Ohio State University team at the University of Udaipur in India, where he made a significant and lasting contribution to the dairy program in that country. The second was a three-year assignment in Brazil, where he assisted in the development of an academic program in dairy technology in the Department of Food Technology, College of Agriculture, at the University of Sao Paulo.

Walter Slatter was a dedicated teacher and academic advisor who gave generously of his time to work with students in extra curricular activities. He derived great pleasure and satisfaction from

RESOLUTIONS IN MEMORIAMs (contd)

Walter L. Slatter (contd)

counseling undergraduate students and coaching The Ohio State University Dairy Foods Evaluation team. He coached more than 20 teams during his career, which most often placed in the top five of the 25-30 universities participating in the annual International Collegiate Dairy Foods Evaluation Contest. Five of his teams placed first in the competition and he was honored as Coach of the Year five times. As alumni, his former team members revered Professor Slatter and continually testified to the value of the skills acquired under his tutelage in their professional careers.

Professor Slatter gave invaluable service to the dairy industry in Ohio and nationally through his extension work. He was a tireless proponent of programs and activities for improving the quality of milk and milk products. In cooperation with the Ohio Departments of Health and Agriculture, Dr. Slatter authored a manual for milk haulers which became the premier publication nationally for educating milk haulers and governing their actions. He was also the University liaison to the Ohio Swiss Cheese Association, serving as secretary-treasurer and technical advisor of this organization from 1947-57 and technical advisor from 1963-66.

Dr. Slatter's professional associations included long-time membership in the American Dairy Science Association, where he served on numerous committees including membership, dairy products judging, international affairs, and the student affiliate committee. He also served on the Scholarship Awards Committee of the Milk Industry Foundation.

On behalf of the University community, the Board of Trustees expresses to the family of Professor Walter L. Slatter its deepest sympathy and sense of understanding of their loss. It was directed that this resolution be inscribed upon the minutes of the Board of Trustees and that a copy be tendered to his family as an expression of the Board's heartfelt sympathy.

Joel T. Walker

The Board of Trustees of The Ohio State University expresses its sorrow upon the death on March 21, 2002, of Dr. Joel T. Walker, Professor in the Department of Food, Agricultural, and Biological Engineering.

Born in Knoxville, Tennessee, Professor Walker received B.S. and Ph.D. degrees in agricultural engineering from the University of Tennessee in 1974 and 1979, respectively. He served on the faculty at the University of Arkansas from 1979-2000, including a year as interim head of the Department of Biological and Agricultural Engineering. He had been a professor at The Ohio State University since January 2001.

He was nationally and internationally recognized for teaching and research. He wrote over 120 scholarly publications and received three Outstanding Teacher awards. His students won the American Society of Agricultural Engineers (ASAE) student design competition twice. He had broad interests in machinery for farming and the food industry. He was a recognized expert in aerial application of pesticides.

Professor Walker had a great spirit for taking on new challenges and investigating new areas. He enjoyed staying at the cutting edge himself, and always pushed his students to excel. He was equally comfortable and competent whether discussing technical issues with other engineers or teaching and working with farmers and agricultural advisors.

Joel Walker was an active member of his professional organization, the American Society of Agricultural Engineers. He was an associate editor for the Power & Machinery Division technical committee within the ASAE since 1983, served three years as editor, and was a member of the Publication Council since 1998. He served on several technical committees, including one on precision agriculture.

RESOLUTIONS IN MEMORIAMs (contd)

Joel T. Walker (contd)

Dr. Walker had taken on an active role in the University community. He was on the College of Engineering Committee for Academic Affairs. Within the Department of Food, Agricultural, and Biological Engineering, he headed an industry internship program, was on the Staff Awards Committee, and was the procedure oversight designee for the promotion and tenure process.

On behalf of the University community, the Board of Trustees expresses to the family of Professor Joel T. Walker its deepest sympathy. It was directed that this resolution be inscribed upon the minutes of the Board of Trustees and that a copy be tendered to his family as an expression of the Board's heartfelt sympathy.

Harold S. Weiss

The Board of Trustees of The Ohio State University expresses its sorrow upon the death on February 25, 2002, of Harold S. Weiss, Professor Emeritus in the Department of Physiology and Cell Biology.

After service in the U.S. Air Force as a meteorologist and air traffic controller during World War II, Professor Weiss received the B.S. degree in chemistry and the M.S. and Ph.D. degrees in physiology from Rutgers University. He taught at Rutgers University before coming to The Ohio State University in 1963. He was a professor in the Department of Physiology for 28 years when he was granted professor emeritus status in 1991. During this time, Professor Weiss maintained an outstanding record of teaching, research, and service.

Professor Weiss taught with distinction in almost every course offered by the Department of Physiology, from undergraduate to professional to advanced graduate level courses. He also was the advisor of 11 graduate students who received the M.S. degree and an additional 11 who received the Ph.D. degree. Many of Professor Weiss' students have gone on to achieve academic distinction.

Professor Weiss was an exceptionally productive faculty member, publishing over 120 full-length papers in the fields of basic and applied environmental physiology. These studies included physiological responses to acceleration and artificial atmospheres, blood pressure regulation, atherosclerosis, and the carcinogenic effects of environmental factors. He received research support from national sources for nearly a quarter of a century.

Harold Weiss' professional service record was exemplary. Most notably he was considered a tireless champion of academic freedom and faculty governance. His clarity of thought concerning the role of faculty in a University community shaped the views of many of his colleagues. He was the primary architect of the governance system of the College of Medicine and Public Health and served as a University senator. In recognition of his leadership in support of academic freedom, he was awarded the Louis Nemzer Award in 1988 by The Ohio State University Chapter of the American Association of University Professors.

At a time when some believe that a faculty member can no longer be excellent in teaching, research, and service, Professor Weiss was truly exceptional in each of these components that collectively define a professor.

On behalf of the University community, the Board of Trustees expresses to the family of Professor Emeritus Harold S. Weiss its deepest sympathy and sense of understanding of their loss. It was directed that this resolution be inscribed upon the minutes of the Board of Trustees and that a copy be tendered to his family as an expression of the Board's heartfelt sympathy.

REPORT OF RESEARCH CONTRACTS AND GRANTS

Resolution No. 2002-121

Synopsis: The reports on research and other sponsored program contracts and grants and the summary for March 2002 are presented for Board acceptance.

WHEREAS monies are solicited and received on behalf of the University from governmental, industrial, and other agencies in support of research, instructional activities, and service; and

WHEREAS such monies are received through The Ohio State University Research Foundation:

NOW THEREFORE

BE IT RESOLVED, That the research agreement between The Ohio State University and The Ohio State University Research Foundation for the contracts and grants reported herein during the month of March 2002 be approved.

**OSU STUDENT HEALTH INSURANCE PROGRAM
PLAN FOR 2002-2003**

Resolution No. 2002-122

Synopsis: The Ohio State University Student Health Insurance Program Plan for 2002-2003, is proposed.

WHEREAS on June 2, 2000, this Board awarded the medical insurance program contract to Koster Insurance Agency, following a competitive bid process, and renewed with Vision Service Plan and Delta Dental of Ohio for respective coverage effective Autumn term 2000, subject to renewal thereafter; and

WHEREAS the University has the opportunity to seek renewal of the program with the current carriers or competitively bid the insurance program; and

WHEREAS the current carriers Koster Insurance Agency, Delta Dental of Ohio and Vision Service Plan, have offered renewal rates that are competitive in the insurance market and appropriate to our history of claims experience; and

WHEREAS after consideration of the expressed needs and concerns of the students who purchase the insurance, the OSU Student Health Insurance Committee has recommended keeping Koster Insurance Agency as the administrator of the commercially insured PPO portion of the plan, Delta Dental of Ohio the insurer of the dental portion, Vision Service Plan the insurer of the vision portion and contracting with American WholeHealth Networks, Inc., to provide the complementary and alternative medical services portion of the plan. Each of these contracts will be for a period of one year and will provide existing benefits with the exception of the following changes:

1. Increase the limits for medical evacuation and repatriation to the more competitive levels of \$50,000 and \$15,000 respectively, especially important for international students and students traveling internationally.
2. Increase the maximum annual amount each insured individual pays out-of-pocket each plan year. The new maximums will be \$5,000 for in-network providers and \$10,000 for out-of-network providers.
3. Increase the annual out-of-network deductible to \$500 per person with a maximum deductible of \$1,500 per family.

**OSU STUDENT HEALTH INSURANCE PROGRAM
PLAN FOR 2002-2003 (contd)**

4. Decrease the out-of-network coverage to 60% of reasonable and customary charges.
5. Provide additional psychiatric services at Counseling and Consultation Services (CCS). This improvement will enable more services to be performed within CCS to more accurately reflect the demand for these services; therefore, fewer external referrals will be required.
6. Provide a new coverage for limited home health care services at 90% in-network and 70% out-of-network.
7. Implement a complementary and alternative medical services program that will offer discounts on services such as acupuncture, nutritional services and products, and massage therapy when individuals go to a credentialed, network practitioner. Individuals will be responsible for the full cost of services less the applicable discount.
8. Eliminate technical schools from eligibility in the Student Health Insurance Plan to prevent confusion in plan administration.
9. Implement a system to prevent students from changing type of coverage (comprehensive to medical or medical to comprehensive) on a quarter-by-quarter basis within the academic year.

WHEREAS this plan is fully funded by student premiums and will be available to eligible OSU students; and

WHEREAS the following are the tentative **quarterly** premium rates; final rates will be submitted for approval at the June Board of Trustees meeting as part of the fees and charges submittal. (Final rates may be lower than the levels stated here, but will be no higher. Categories will remain as stated here, with only price subject to change):

Comprehensive Plan Rates (includes vision and dental benefits):

Enrollment Category	Quarterly Premium	Monthly Premium	Percent Increase
Student Only	\$ 290	\$ 96.67	15.5%
Student + Spouse	\$ 742	\$247.33	15.6%
Student + Children	\$ 748	\$249.33	15.6%
Student + Family	\$1,002	\$334.00	15.6%

Medical ONLY Plan Rates (no vision or dental benefits):

Enrollment Category	Quarterly Premium	Monthly Premium	Percent Increase
Student Only	\$274	\$ 91.33	17.6%
Student + Spouse	\$701	\$233.67	17.6%
Student + Children	\$707	\$235.67	17.6%
Student + Family	\$947	\$315.67	17.6%

Comparable insurance rates will be charged to students on the semester system, adjusting only for the length of the term.

NOW THEREFORE

**OSU STUDENT HEALTH INSURANCE PROGRAM
PLAN FOR 2002-2003 (contd)**

BE IT RESOLVED, That Koster Insurance Agency, Delta Dental of Ohio, Vision Service Plan and American WholeHealth Networks, Inc., be awarded the OSU Student Health Insurance Program contracts effective Autumn term 2002, for a period of one (1) contract year.

REPORT ON UNIVERSITY DEVELOPMENT

Resolution No. 2002-123

Synopsis: The report on the receipt of gifts and the summary for March 2002 are presented for Board acceptance.

WHEREAS monies are solicited and received on behalf of the University from alumni, industry, and various individuals in support of research, instructional activities, and service; and

WHEREAS such gifts are received through The Ohio State University Development Fund and The Ohio State University Foundation; and

WHEREAS this report includes the establishment of eighteen (18) new named endowed funds and the amendment of three (3) named endowed funds:

NOW THEREFORE

BE IT RESOLVED, That the acceptance of the report from The Ohio State University Development Fund and The Ohio State University Foundation during the month of March 2002 be approved.

REPORT ON UNIVERSITY DEVELOPMENT (contd)

TOTAL UNIVERSITY PRIVATE SUPPORT

July through March
2000-2001 Compared to 2001-2002

GIFT RECEIPTS BY DONOR TYPE

	Dollars July through March		
	<u>2000-2001</u>	<u>2001-2002</u>	<u>%Change</u>
Individuals:			
Alumni (Current Giving)	\$24,412,090	\$26,715,975	9
Alumni (From Bequests)	<u>5,702,103</u>	<u>4,046,255</u>	(29)
Alumni Total	\$30,114,193	\$30,762,230	2
Non-Alumni (Current Giving)	\$20,450,743	\$12,842,030	(37)
Non-Alumni (From Bequests)	<u>9,661,057</u>	<u>2,798,230</u>	(71)
Non-Alumni Total	\$30,111,800	\$15,640,260	(48)
Individual Total	\$60,225,993	\$46,402,490	(23) ^A
Corporations/Corp/Foundations	\$30,317,908	\$33,050,632	9
Private Foundations	\$11,651,200	\$15,239,640	31 ^B
Associations and Other Organizations	<u>\$3,200,819</u>	<u>\$3,394,610</u>	6
Total	\$105,395,920	\$98,087,372	(7)

NOTES

- A Overall individual giving is down 23% in that gifts at the \$10,000 or more level are down 24% (\$44.9 million from 473 gifts last year compared with \$30.4 million from 394 gifts this year).
- B Foundation giving at the \$10,000 or more level is up for the first eight months of the fiscal year (\$10.9 million from 147 gifts last year; \$14.5 million from 167 gifts this year).

REPORT ON UNIVERSITY DEVELOPMENT (contd)

TOTAL UNIVERSITY PRIVATE SUPPORT (contd)

July from March
2000-2001 Compared to 2001-2002

GIFT RECEIPTS BY PURPOSE

	Dollars July through March		
	<u>2000-2001</u>	<u>2001-2002</u>	<u>% Change</u>
Gift Receipts to Current Use and Endowment Funds:			
Buildings/Equipment	\$19,842,982	\$16,773,214	(15)
Faculty Support	\$9,369,255	\$10,346,272	10
Program Support	\$57,567,704	\$53,045,925	(8)
Student Financial Aid	\$10,089,774	\$10,447,172	4
Annual Funds-Colleges/Departments	\$7,264,753	\$6,472,111	(11)
Annual Funds-University	<u>\$1,261,452</u>	<u>\$1,002,678</u>	(21)
Total	\$105,395,920	\$98,087,372	(7)

GIFT ADDITIONS TO ENDOWMENT

Dollars
July through March

<u>2000-2001</u>	<u>2001-2002</u>	<u>% Change</u>
\$28,050,663	\$32,304,772	15

REPORT ON UNIVERSITY DEVELOPMENT (contd)

THE OHIO STATE UNIVERSITY DEVELOPMENT FUND

	<u>Previous Gifts</u>	<u>Current Gifts</u>	<u>Total Gifts</u>
<u>Establishment of Named Endowed Funds</u>			
The Honda/TRC Funds Endowment Fund for the Growth of Transportation (Used to support transportation activities within the College of Engineering; provided by a gift from the Transportation Research Center, Inc.)		\$2,000,000.00	\$2,000,000.00
The Honda/TRC Funds Endowment Fund for the Growth of Student Activities (Used to support student activities within the College of Engineering; provided by a gift from Transportation Research Center, Inc.)		\$1,000,000.00	\$1,000,000.00
The Excellence in Pet Care Endowment Fund (Used to enhance the care of small and large animal patients; provided by gifts from alumni and friends of the College of Veterinary Medicine)		\$50,000.00	\$50,000.00
The Robert A. Waddell Tau Beta Pi Scholarship Fund (Used to provide scholarships for student members of Tau Beta Pi honorary; provided by gifts from the estate of Robert A. Waddell and the University's student chapter of Tau Beta Pi)	\$27,592.00		\$27,592.00
The Schulte Scholarship Fund (Used to provide scholarships for students enrolled at The Ohio State University at Lima; provided by gifts from Robert M. and Grace Schulte)		\$25,515.00	\$25,515.00
The Micki Zartman Service Learning Fund (Used to promote educational outreach for the College of Food, Agricultural, and Environmental Sciences; provided by gifts from the College of Food, Agricultural, and Environmental Sciences Vice President's Fund)		\$25,000.00	\$25,000.00
Crawford County 4-H Endowment Fund (Used to support the Crawford County 4-H program; provided by gifts from friends of Crawford County 4-H) (grandfathered)		\$15,230.00	\$15,230.00
<u>Change in Description of Named Endowed Funds</u>			
The Sunder H. Advani Memorial in Applied Mechanics Fund The Glenn O. and Lois S. Schwab Scholarship Fund			

REPORT ON UNIVERSITY DEVELOPMENT (contd)

THE OHIO STATE UNIVERSITY FOUNDATION

	<u>Previous Gifts</u>	<u>Current Gifts</u>	<u>Total Gifts</u>
<u>Establishment of Named Endowed Funds</u>			
The H. Frederick Krimendahl II Presidential Scholarship Fund for Academic Excellence (Used to provide a scholarship for an entering freshman presidential scholar; provided by gifts from the H. Frederick Krimendahl II Foundation and/or West End Road Fund at New York Community Trust)		\$250,000.00	\$250,000.00
The Jane Ann Evans Nielsen Endowed Scholarship Fund in Political Science (Used to provide undergraduate scholarships to political science majors; provided by gifts from Lloyd Roberts Evans and Jane Ann Evans Nielsen)		\$62,155.00	\$62,155.00
The Dr. Louis and Raye Carlin Endowed Scholarship Fund (Used to supplement tuition for a student pursuing a D.V.M. degree; provided by a gift from Raye Carlin)		\$50,000.00	\$50,000.00
The Herbert and Dorothy Joseph Fenburr Scholarship Endowment Fund for Geography (Used to provide scholarships to students majoring in geography; provided by gifts from Dorothy Joseph Fenburr)	\$50,000.00		\$50,000.00
The Ohio State University Civil Engineering Alumni Association Scholarship Fund (Used to support civil or environmental engineering majors; provided by gifts from OSUCEAA and its members and from the estate of Samuel C. Pritchard)		\$36,361.00	\$36,361.00
The Joan Bisesi Fund for Head and Neck Oncology Research (Used to support head and neck oncology research at The Arthur G. James Cancer Hospital and Richard J. Solove Research Institute; provided by gifts from family and friends of Joan Bisesi)	\$31,541.00		\$31,541.00
The McMaster Physics Research Endowment Fund (Used to provide research support for a senior faculty member in the Department of Physics; provided by gifts from Harold and Helen McMaster)		\$30,000.00	\$30,000.00

REPORT ON UNIVERSITY DEVELOPMENT (contd)

THE OHIO STATE UNIVERSITY FOUNDATION (contd)

	<u>Previous Gifts</u>	<u>Current Gifts</u>	<u>Total Gifts</u>
<u>Establishment of Named Endowed Funds (contd)</u>			
The John and Cindy Feltz Scholarship Fund (Used to provide scholarships to incoming freshmen from Greene County Ohio majoring in engineering or education; provided by gifts from John and Cindy Feltz)		\$29,564.50	\$29,564.50
The Joseph Richard and Sally Scott Yerina Endowment Fund for Cancer Research (Used to support cancer research at The Arthur G. James Cancer Hospital and Richard J. Solove Research Institute; provided by gifts from Linda and David Zuby, Catherine Ong, Earl Yerina, John Yerina, Debbie and Jim Yerina, and Mary Yerina)		\$28,724.63	\$28,724.63
The Ken Feintheil Athletic Scholarship Fund (Used to supplement the student-athlete grant-in-aid scholarship costs of a quarterback on the football team or an infielder on the baseball team; provided by gifts from Ken Feintheil)		\$25,060.00	\$25,060.00
The Dana M. Spuhler Memorial Scholarship Fund in Computer and Information Science (Used to provide scholarship support for computer and information science students; provided by a gift from Cheryl Spuhler)		\$25,000.00	\$25,000.00
<u>Change in Description of Named Endowed Fund</u>			
The Clara Hilberg Teller Endowed Scholarship Fund			
Total	\$109,133.00	\$3,652,610.13	\$3,761,743.13

THE OHIO STATE UNIVERSITY DEVELOPMENT FUND

Establishment of Named Endowed Funds

The Honda/TRC Funds Endowment Fund
for the Growth of Transportation Activities

The Honda/TRC Funds Endowment Fund for the Growth of Transportation Activities was established on May 3, 2002, by the Board of Trustees of The Ohio State University with a gift from the Transportation Research Center, Inc. ("TRC") of East Liberty, Ohio, in recognition of Honda Motor Co., Ltd's and Honda of America Mfg., Inc.'s (collectively "Honda") established interest in developing world-class, interdisciplinary transportation-related research and academic programs.

All gifts are to be invested in the University's Permanent Endowment Fund, under the rules and regulations adopted by the Board of Trustees of The Ohio State University, with the right to invest and reinvest as occasion dictates.

REPORT ON UNIVERSITY DEVELOPMENT (contd)

THE OHIO STATE UNIVERSITY DEVELOPMENT FUND (contd)

Establishment of Named Endowed Funds (contd)

The Honda/TRC Funds Endowment Fund
for the Growth of Transportation Activities (contd)

The annual income shall be used by the dean of the College of Engineering to support transportation activities within the College of Engineering. The Honda-OSU Planning Team ("Team") or its successor will offer the dean recommendations for the use of the income. The dean will report annually to the Team, TRC, and Honda on results of the previous year and the goals, objectives, and plans for the upcoming year; these reports will include the use of all fund earnings over the same two-year period.

It is the desire of the donor that this fund should benefit the University in perpetuity. If the need for this fund should cease to exist or so diminish as to provide unused income, then another use shall be designated by the Board of Trustees in consultation with the appropriate college dean, school director, department chairperson, or program administrative officer in order to carry out the desire of the donor.

\$2,000,000.00

The Honda/TRC Funds Endowment Fund
for the Growth of Student Activities

The Honda/TRC Funds Endowment Fund for the Growth of Student Activities was established on May 3, 2002, by the Board of Trustees of The Ohio State University with a gift from the Transportation Research Center, Inc. ("TRC") of East Liberty, Ohio, in recognition of Honda Motor Co., Ltd's and Honda of America Mfg., Inc.'s (collectively "Honda") established interest in developing world-class, interdisciplinary transportation-related research and academic programs.

All gifts are to be invested in the University's Permanent Endowment Fund, under the rules and regulations adopted by the Board of Trustees of The Ohio State University, with the right to invest and reinvest as occasion dictates.

The annual income shall be used by the dean of the College of Engineering to support student activities within the College of Engineering. The Honda-OSU Planning Team ("Team") or its successor will offer the dean recommendations for the use of the income. The dean will report annually to the Team, TRC, and Honda on results of the previous year and the goals, objectives, and plans for the upcoming year; these reports will include the use of all fund earnings over the same two-year period.

It is the desire of the donor that this fund should benefit the University in perpetuity. If the need for this fund should cease to exist or so diminish as to provide unused income, then another use shall be designated by the Board of Trustees in consultation with the appropriate college dean, school director, department chairperson, or program administrative officer in order to carry out the desire of the donor.

\$1,000,000.00

The Excellence in Pet Care Endowment Fund

The Excellence in Pet Care Endowment Fund was established on May 3, 2002, by the Board of Trustees of The Ohio State University with gifts from alumni and friends of the College of Veterinary Medicine.

REPORT ON UNIVERSITY DEVELOPMENT (contd)

THE OHIO STATE UNIVERSITY DEVELOPMENT FUND (contd)

Establishment of Named Endowed Funds (contd)

The Excellence in Pet Care Endowment Fund (contd)

All gifts are to be invested in the University's Permanent Endowment Fund, under the rules and regulations adopted by the Board of Trustees of The Ohio State University, with the right to invest and reinvest as occasion dictates.

The annual income will be used at the discretion of the dean of the College of Veterinary Medicine to further enhance the care of both small and large animal patients.

It is the desire of the donors that this fund should benefit the University in perpetuity. If the need for this fund should cease to exist or so diminish as to provide unused income, then another use shall be designated by the Board of Trustees as recommended by the dean of the College of Veterinary Medicine to carry out the desire of the donors.

\$50,000.00

The Robert A. Waddell Tau Beta Pi Scholarship Fund

The Robert A. Waddell Tau Beta Pi Scholarship Fund was established on May 3, 2002, by the Board of Trustees of The Ohio State University with gifts from the estate of Robert A. Waddell (M.S. 1938) and the University's student chapter of Tau Beta Pi.

All gifts are to be invested in the University's Permanent Endowment Fund, under the rules and regulations adopted by the Board of Trustees of The Ohio State University, with the right to invest and reinvest as occasion dictates.

The annual income shall be used for two or more scholarships for student members of Tau Beta Pi honorary. Selection will be based on demonstrated leadership and extracurricular activities. The dean of the College of Engineering will be responsible for the selection of the award recipients in consultation with the chapter's scholarship selection committee and the University Committee on Student Financial Aid.

One of the yearly scholarships will be in memory of Robert A. Waddell and awarded to a member who is majoring in either electrical engineering or computer and information science. All other scholarship support will be in honor of former chapter advisor and Professor Emeritus Frederick D. Meyers (B.M.E. 1949, M.B.A. 1952) and will be available to qualified chapter members regardless of major. All scholarships are awarded on a one-year basis. Recipients are eligible to compete for renewed awards.

It is the desire of the donors that this fund should benefit the University in perpetuity. If the need for this fund should cease to exist or so diminish as to provide unused income, then another use shall be designated by the Board of Trustees in consultation with the appropriate college dean or program administrative officer in order to carry out the desire of the donors.

\$27,592.00

The Schulte Scholarship Fund

The Schulte Scholarship Fund was established on May 3, 2002, by the Board of Trustees of The Ohio State University with gifts from Robert M. (B.S. 1960) and Grace Schulte.

REPORT ON UNIVERSITY DEVELOPMENT (contd)

THE OHIO STATE UNIVERSITY DEVELOPMENT FUND (contd)

Establishment of Named Endowed Funds (contd)

The Schulte Scholarship Fund (contd)

All gifts are to be invested in the University's Permanent Endowment Fund, under the rules and regulations adopted by the Board of Trustees of The Ohio State University, with the right to invest and reinvest as occasion dictates.

The annual income shall be used to provide scholarships for students enrolled at The Ohio State University at Lima as determined by criteria established by Robert M. and Grace Schulte. The scholarship will be awarded in consultation with the University Committee on Student Financial Aid.

It is the desire of the donors that this fund should benefit the University in perpetuity. If the need for this fund should cease to exist or so diminish as to provide unused income, then another use shall be designated by the Board of Trustees in consultation with the appropriate administrative official of the University who is then directly responsible for The Ohio State University at Lima in order to carry out the desire of the donors.

\$25,515.00

The Micki Zartman Service Learning Fund

The Micki Zartman Service Learning Fund was established on May 3, 2002, by the Board of Trustees of The Ohio State University with gifts from the College of Food, Agricultural, and Environmental Sciences Vice President's Fund to honor the dedication and leadership that Micki Zartman (B.S.H.E. 1991) has provided student service learning initiatives.

All gifts are to be invested in the University's Permanent Endowment Fund, under the rules and regulations adopted by the Board of Trustees of The Ohio State University, with the right to invest and reinvest as occasion dictates.

The annual income shall be used to support undergraduate students, graduate students, faculty, staff, agricultural student organizations, or external stakeholders who significantly promote agricultural educational outreach for the College of Food, Agricultural, and Environmental Sciences. Projects will be innovative, scholarly, and collaborative, and will enhance service learning. Scholarships will be awarded in consultation with the University Committee on Student Financial Aid.

It is the desire of the donor that this fund should benefit the University in perpetuity. If the need for this fund should cease to exist or so diminish as to provide unused income, then another use shall be designated by the Board of Trustees in consultation with the vice president for Agricultural Administration and University Outreach, and executive dean for Food, Agricultural and Environmental Sciences or their successor.

\$25,000.00

Crawford County 4-H Endowment Fund

The Crawford County 4-H Endowment Fund was established on May 3, 2002, by the Board of Trustees of The Ohio State University through current and future gifts from friends of Crawford County 4-H.

All gifts are to be invested in the University's Permanent Endowment Fund, under the rules and regulations adopted by the Board of Trustees of The Ohio State University, with the right to invest and reinvest as occasion dictates.

REPORT ON UNIVERSITY DEVELOPMENT (contd)

THE OHIO STATE UNIVERSITY DEVELOPMENT FUND (contd)

Establishment of Named Endowed Funds (contd)

Crawford County 4-H Endowment Fund (contd)

The annual income shall be used to support the Crawford County 4-H program. The support may include but is not limited to the funding of scholarships and awards for 4-H members, volunteer leaders and friends of 4-H, sponsoring seminars and programs, and purchasing material and services that will supplement 4-H programming or increase the visibility and public support of 4-H in Crawford County. All expenditures from this fund shall be approved by the Crawford County 4-H Advisory Committee. Scholarships will be awarded in consultation with the University Committee on Student Financial Aid.

If the need for this fund should cease to exist or so diminish as to provide unused income, then another use shall be designated by the Board of Trustees in consultation with the director of the Ohio State University Extension and the Crawford County 4-H Advisory Committee in order to carry out the desire of the donors.

\$15,230.00
(grandfathered)

Change in Description of Named Endowed Funds

The Sunder H. Advani Memorial in Applied Mechanics Fund

The Sunder H. Advani Memorial in Applied Mechanics Fund was established November 5, 1999, by the Board of Trustees of The Ohio State University with gifts from friends, colleagues, and former students in memory of Professor Sunder H. Advani. The description was revised on May 3, 2002.

All gifts are to be invested in the University's Permanent Endowment Fund, under the rules and regulations adopted by the Board of Trustees of The Ohio State University, with the right to invest and reinvest as occasion dictates.

The annual earnings shall provide one or more scholarships to students for excellence in applied mechanics. The scholarship committee in the Department of Mechanical Engineering will select the recipients of the scholarships in consultation with the University Committee on Student Financial Aid.

It is the desire of the donors that this fund should benefit the University in perpetuity. If the need for this fund should cease to exist or so diminish as to provide unused income, then another use shall be designated by the Board of Trustees in consultation with the appropriate college dean and department chairperson in order to carry out the desire of the donors.

The Glenn O. and Lois S. Schwab Scholarship Fund

The Glenn O. and Lois S. Schwab Scholarship Fund was established February 3, 1995, by the Board of Trustees of The Ohio State University with gifts to The Ohio State University Development Fund from Glenn O. Schwab, Professor Emeritus in the Department of Food, Agricultural and Biological Engineering, and Lois S. Schwab of Powell, Ohio. The description was revised on May 3, 2002.

All gifts are to be invested in the University's Permanent Endowment Fund, under the rules and regulations adopted by the Board of Trustees of The Ohio State University, with the right to invest and reinvest as occasion dictates.

REPORT ON UNIVERSITY DEVELOPMENT (contd)

THE OHIO STATE UNIVERSITY DEVELOPMENT FUND (contd)

Change in Description of Named Endowed Funds (contd)

The Glenn O. and Lois S. Schwab Scholarship Fund (contd)

The annual income of 1.7278 shares shall be directed to the College of Biological Sciences with the income from the remaining shares directed to the College of Food, Agricultural, and Environmental Sciences.

In the College of Food, Agricultural and Environmental Sciences, the annual income for a scholarship(s) shall be awarded to a second-quarter junior or beyond, or a senior student majoring in Food, Agricultural, and Biological Engineering. The student must possess a minimum overall grade point average of 3.3 on a 4.0 scale and receive the highest grade in the design course in soil and water conservation engineering or its equivalent. If no student meets the 3.3 grade point average requirement, the scholarship will carry over to the next year and be added to that for the current year. Selection of the recipient will be made by the scholarship committee in consultation with the chairperson of the Department of Food, Agricultural, and Biological Engineering and the University Committee on Student Financial Aid.

In the College of Biological Sciences, the scholarship(s) shall be awarded to a second-quarter junior or senior student in the Department of Evolution, Ecology, and Organismal Biology who possesses the highest overall grade point average of at least 3.3 on a 4.0 scale and has completed one or more courses in parasitology, entomology, anatomy, ornithology, or other advanced zoology courses. If no student meets the 3.3 grade point average requirement, the scholarship will carry over to the next year and be added to that for the current year. The selection will be made by the chairperson of the Department of Evolution, Ecology, and Organismal Biology and the dean of the College of Biological Sciences in consultation with the University Committee on Student Financial Aid.

It is the desire of the donors that this fund should benefit the University in perpetuity. If the need for this fund should cease to exist or so diminish as to provide unused income, then another use shall be designated by the Board of Trustees in consultation with the chairpersons of the Departments of Food, Agricultural, and Biological Engineering and Evolution, Ecology, and Organismal Biology or their successors, or program administrative officer in order to carry out the desire of the donors.

THE OHIO STATE UNIVERSITY FOUNDATION

Establishment of Named Endowed Funds

The H. Frederick Krimendahl II Presidential Scholarship
Fund for Academic Excellence

The H. Frederick Krimendahl II Presidential Scholarship Fund for Academic Excellence was established on May 3, 2002, in accordance with the guidelines approved by the Board of Directors of The Ohio State University Foundation, with a gift from the H. Frederick Krimendahl II Foundation and/or West End Road Fund at New York Community Trust.

All gifts are to be invested by the Foundation, under the rules and regulations adopted by the Foundation's Board of Directors, with the right to invest and reinvest as occasion dictates

The annual income shall be used to provide a scholarship for an entering freshman presidential scholar. The scholarship will continue through the student's senior year as long as he or she maintains eligibility as a presidential scholar. When the recipient graduates, a new freshman will be named. The scholarship will be awarded in consultation with the University Committee on Student Financial Aid.

REPORT ON UNIVERSITY DEVELOPMENT (contd)

THE OHIO STATE UNIVERSITY FOUNDATION (contd)

Establishment of Named Endowed Funds (contd)

The H. Frederick Krimendahl II Presidential Scholarship
Fund for Academic Excellence (contd)

It is the desire of the donor that this fund should benefit the University in perpetuity. If the need for this fund should cease to exist or so diminish as to provide unused income, then another use shall be designated by the Foundation Board in consultation with the director of the University Honors Program in order to carry out the desire of the donor.

\$250,000.00

The Jane Ann Evans Nielsen Endowed Scholarship Fund in Political Science

The Jane Ann Evans Nielsen Endowed Scholarship Fund in Political Science in the College of Social and Behavioral Sciences was established on May 3, 2002, in accordance with the guidelines approved by the Board of Directors of The Ohio State University Foundation, with gifts from Lloyd Roberts Evans (B.A. 1933) and Jane Ann Evans Nielsen (B.A. 1936, B.S. 1936).

All gifts are to be invested by the Foundation, under the rules and regulations adopted by the Foundation's Board of Directors, with the right to invest and reinvest as occasion dictates.

The annual income shall be used to provide undergraduate scholarships, based on merit and need, to junior or senior political science majors with a 3.4 GPA or higher and a wide range of interests. The scholarship will be awarded in consultation with the University Committee on Student Financial Aid.

It is the desire of the donors that this fund should benefit the University in perpetuity. If the need for this fund should cease to exist or so diminish as to provide unused income, then another use shall be designated by the Foundation Board as recommended by the dean of the College of Social and Behavioral Sciences in consultation with the chairperson of the Department of Political Science in order to carry out the desire of the donors.

\$62,155.00

The Dr. Louis and Raye Carlin Endowed Scholarship Fund

The Dr. Louis (D.V.M. 1942) and Raye Carlin Endowed Scholarship Fund was established on May 3, 2002, in accordance with the guidelines approved by the Board of Directors of The Ohio State University Foundation, with a gift from Dr. Carlin's beloved wife of 59 years, Raye Carlin. This memorial scholarship honors Dr. and Mrs. Carlin's commitment to helping young people grow to be productive, healthy, and honorable adults.

All gifts are to be invested by the Foundation, under the rules and regulations adopted by the Foundation's Board of Directors, with the right to invest and reinvest as occasion dictates.

The annual income shall be used to supplement tuition for one (1) third- or fourth-year student based on academic achievement, strong leadership, and financial need. The student must be enrolled at The Ohio State University, pursuing a D.V.M. degree in the College of Veterinary Medicine. Recipients will be selected by the dean of the College of Veterinary Medicine in consultation with the associate dean for Student Affairs in the College and the University Committee on Student Financial Aid.

REPORT ON UNIVERSITY DEVELOPMENT (contd)

THE OHIO STATE UNIVERSITY FOUNDATION (contd)

Establishment of Named Endowed Funds (contd)

The Dr. Louis and Raye Carlin Endowed Scholarship Fund (contd)

It is the desire of the donor that this fund should benefit the University in perpetuity. If the need for this fund should cease to exist or so diminish as to provide unused income, then another use shall be designated by the Foundation Board as recommended by the person or unit with spending authority and/or appropriate university official in order to carry out the desire of the donor.

\$50,000.00

The Herbert and Dorothy Joseph Fenburr Scholarship
Endowment Fund for Geography

The Herbert (B.Ch.E. 1934, M.S. 1935, Ph.D. 1937) and Dorothy Joseph Fenburr Scholarship Endowment Fund for Geography was established on May 3, 2002, in accordance with the guidelines approved by the Board of Directors of The Ohio State University Foundation, with gifts from Dorothy Joseph Fenburr (B.A. 1935).

This endowment is funded by a \$50,000 cash gift given to The Ohio State University Foundation and will be supplemented by an estate bequest of \$50,000 by Dorothy Joseph Fenburr.

All gifts are to be invested by the Foundation, under the rules and regulations adopted by the Foundation's Board of Directors, with the right to invest and reinvest as occasion dictates.

The annual income shall be used according to needs and opportunities available to graduate and undergraduate students majoring in geography. For graduate students, establishing a base for dissertation research (pre-dissertation support to establish a solid foundation for dissertation research), or for dissertation research itself, will be an important objective. For all students, graduate and undergraduate, supplementary support for attending relevant workshops of professional conferences that lead to professional development also will be an important objective. In particular cases, supplementary support for tuition and the like might occur. Ultimately, use of these funds is at the discretion of the Department of Geography chairperson, but the gift assumes that the range of uses will be broad and of significant benefit to students, whatever their level.

If for any reason the income is not fully used in a given year, it may be applied towards principal or retained as unused income to be used the following year. The latter choice is preferred.

It is the desire of the donor that this fund should benefit the University in perpetuity. If the need for this fund should cease to exist or so diminish as to provide unused income, then another use shall be designated by the Foundation Board in consultation with Dorothy Joseph Fenburr or, after her lifetime, with the chairperson of the Department of Geography and dean of the College of Social and Behavioral Sciences in order to carry out the desire of the donor.

\$50,000.00

The Ohio State University Civil Engineering Alumni Association
(OSUCEAA) Scholarship Fund

The Ohio State University Civil Engineering Alumni Association (OSUCEAA) Scholarship Fund was established on May 3, 2002, in accordance with the guidelines approved by the Board of Directors of The Ohio State University Foundation, with gifts from OSUCEAA and its members and from the estate of Samuel C. Pritchard (B.C.E. 1932).

REPORT ON UNIVERSITY DEVELOPMENT (contd)

THE OHIO STATE UNIVERSITY FOUNDATION (contd)

Establishment of Named Endowed Funds (contd)

The Ohio State University Civil Engineering Alumni Association
(OSUCEAA) Scholarship Fund (contd)

All gifts are to be invested by the Foundation, under the rules and regulations adopted by the Foundation's Board of Directors, with the right to invest and reinvest as occasion dictates.

The annual income shall be used by the Department of Civil and Environmental Engineering and Geodetic Sciences (the Department) to support deserving undergraduate civil or environmental engineering majors. A portion of the income will be awarded to a financially and academically deserving senior. At the discretion of the Department, the award may be made to a deserving sophomore or junior. All previous students selected as award recipients and who reapply will be eligible for a single renewal pending review of their academic progress.

The chairperson of the Department will be responsible for administering these scholarships in cooperation with the University Committee on Student Financial Aid. Alumni groups have a special relationship with the University and, therefore, based on past practices may elect to participate in the ranking and recommendation of the scholarship award winners from qualified applicants identified by the Department.

It is the desire of the donors that this fund should benefit the University in perpetuity. If the need for this fund should cease to exist or so diminish as to provide unused income, then another use shall be designated by the Foundation Board in consultation with the appropriate college dean, department chairperson, or program administrative officer, in order to carry out the desire of the donors.

\$36,361.00

The Joan Bisesi Fund for Head and Neck Oncology Research

The Joan Bisesi Fund for Head and Neck Oncology Research at the Comprehensive Cancer Center – The Arthur G. James Cancer Hospital and Richard J. Solove Research Institute was established on May 3, 2002, in accordance with the guidelines approved by the Board of Directors of The Ohio State University Foundation, with gifts from family and friends of Joan Bisesi.

All gifts are to be invested by the Foundation, under the rules and regulations adopted by the Foundation's Board of Directors, with the right to invest and reinvest as occasion dictates.

The annual income shall be used to support head and neck oncology research at the Comprehensive Cancer Center – The Arthur G. James Cancer Hospital and Richard J. Solove Research Institute at The Ohio State University as approved by the director of The Arthur G. James Cancer Hospital and Richard J. Solove Research Institute, the director of the Comprehensive Cancer Center, and the senior vice president for Health Sciences and dean of the College of Medicine and Public Health.

It is the desire of the donors that this fund should benefit the University in perpetuity. If the need for this fund should cease to exist or so diminish as to provide unused income, then another use shall be designated by the Foundation Board in consultation with the director of The Arthur G. James Cancer Hospital and Richard J. Solove Research Institute, the director of the Comprehensive Cancer Center, and the senior vice president of Health Sciences and dean of the College of Medicine and Public Health in order to carry out the desire of the donors.

\$31,541.00

REPORT ON UNIVERSITY DEVELOPMENT (contd)

THE OHIO STATE UNIVERSITY FOUNDATION (contd)

Establishment of Named Endowed Funds (contd)

The McMaster Physics Research Endowment Fund

The McMaster Physics Research Endowment Fund was established on May 3, 2002, in accordance with the guidelines approved by the Board of Directors of The Ohio State University Foundation, with gifts from Harold (B.A. Physics 1938, M.S. Physics 1939) and Helen McMaster of Perrysburg, Ohio, and Sun City West, Arizona.

All gifts are to be invested by the Foundation, under the rules and regulations adopted by the Foundation's Board of Directors, with right to invest and reinvest as occasion dictates.

The annual income shall be used to provide research support for a distinguished senior faculty member in the Department of Physics. The chairperson of the Department of Physics, with the approval of the dean of the College of Mathematical and Physical Sciences, shall designate this faculty member.

It is the desire of the donors that this fund should benefit the University in perpetuity. If the need for this fund should cease to exist or so diminish as to provide unused income, then another use shall be designated by the Foundation Board in consultation with the appropriate college dean or department chairperson in order to carry out the desire of the donors.

\$30,000.00

The John and Cindy Feltz Scholarship Fund

The John and Cindy Feltz Scholarship Fund was established on May 3, 2002, in accordance with the guidelines approved by the Board of Directors of The Ohio State University Foundation, with gifts from John Feltz (B.E.E. 1961, M.B.A 1979) and Cindy Feltz (B.S.Ed. 1961) of Fairborn, Ohio.

All gifts are to be invested by the Foundation, under the rules and regulations adopted by the Foundation's Board of Directors, with the right to invest and reinvest as occasion dictates.

The annual income shall be used to provide scholarships to incoming freshmen from Greene County, Ohio, majoring in engineering or education. The scholarship candidates will be reviewed and recommended to the Office of Student Financial Aid by the Greene County Alumni Club. Should the Greene County Alumni Club become defunct or cease to exist, the College of Engineering and the College of Education may award the scholarship at their discretion in consultation with the University Committee on Student Financial Aid.

It is the desire of the donors that this fund should benefit the University and its students in perpetuity. If the need for this fund should cease to exist or so diminish as to provide unused income, then another use shall be designated by the Foundation Board in consultation with the vice president for University Development and the director of Financial Aid in order to carry out the desire of the donors.

\$29,564.50

REPORT ON UNIVERSITY DEVELOPMENT (contd)

THE OHIO STATE UNIVERSITY FOUNDATION (contd)

Establishment of Named Endowed Funds (contd)

The Joseph Richard and Sally Scott Yerina
Endowment Fund for Cancer Research

The Joseph Richard and Sally Scott Yerina Endowment Fund for Cancer Research at the Comprehensive Cancer Center – The Arthur G. James Cancer Hospital and Richard J. Solove Research Institute was established on May 3, 2002, in accordance with the guidelines approved by the Board of Directors of The Ohio State University Foundation, with gifts from Linda and David Zuby of Charlottesville, Virginia; Catherine Ong and Earl Yerina (B.S. 1981) of Alamo, California; John Yerina of Martinez, California; Jim Yerina of Westerville, Ohio; and Mary Yerina (B.S.Bus.Adm. 1987) of Dublin, Ohio.

All gifts are to be invested by the Foundation, under the rules and regulations adopted by the Foundation's Board of Directors, with the right to invest and reinvest as occasion dictates.

The annual income shall be used to support cancer research with preference given to lymphoma research at the Comprehensive Cancer Center – The Arthur G. James Cancer Hospital and Richard J. Solove Research Institute at The Ohio State University as approved by the director of The Arthur G. James Cancer Hospital and Richard J. Solove Research Institute, the director of the Comprehensive Cancer Center, and the senior vice president for Health Sciences and dean of the College of Medicine and Public Health.

It is the desire of the donors that this fund should benefit the University in perpetuity. If the need for this fund should cease to exist or so diminish as to provide unused income, then another use shall be designated by the Foundation Board in consultation with the director of The Arthur G. James Cancer Hospital and Richard J. Solove Research Institute, the director of the Comprehensive Cancer Center, and the senior vice president for Health Sciences and dean of the College of Medicine and Public Health in order to carry out the desire of the donors.

\$28,724.63

The Ken Feintheil Athletic Scholarship Fund

The Ken Feintheil Athletic Scholarship Fund was established on May 3, 2002, in accordance with the guidelines approved by the Board of Directors of The Ohio State University Foundation, with gifts from Ken Feintheil (B.A. 1955) of Cincinnati, Ohio.

All gifts are to be invested by the Foundation, under the rules and regulations adopted by the Foundation's Board of Directors, with the right to invest and reinvest as occasion dictates.

The annual income shall be used to supplement the student-athlete grant-in-aid scholarship costs of a student athlete who is a quarterback on the football team or an infielder on the baseball team pursuing an undergraduate degree at The Ohio State University. The director of Athletics will select the recipient in consultation with the University Committee on Student Financial Aid.

It is the desire of the donor that this fund should benefit the University in perpetuity. If the need for this fund should cease to exist or so diminish as to provide unused income, then another use shall be designated by the Foundation Board as recommended by the director of Athletics in order to carry out the desire of the donor.

\$25,060.00

REPORT ON UNIVERSITY DEVELOPMENT (contd)

THE OHIO STATE UNIVERSITY FOUNDATION (contd)

Establishment of Named Endowed Funds (contd)

The Dana M. Spuhler Memorial Scholarship
Fund in Computer and Information Science

The Dana M. Spuhler Memorial Scholarship Fund in Computer and Information Science was established on May 3, 2002, in accordance with the guidelines approved by the Board of Directors of The Ohio State University Foundation with a gift in memory of Dana M. Spuhler (B.S.C.I.S. 1982) from his widow, Cheryl Spuhler, of Canton, Ohio.

All gifts are to be invested by the Foundation, under the rules and regulations adopted by the Foundation Board of Directors, with the right to invest and to reinvest as occasion dictates.

The annual income will provide scholarship support for computer and information science students who are academically strong and have demonstrated financial need. Preference will go to students who are graduating from high schools in more rural parts of Ohio. Dana M. Spuhler Scholars may apply for renewed selection. Renewal will depend upon continued financial need, a minimum 3.0 grade point average (on a 4.0 scale), and suitable progress towards a Bachelor of Science in Computer and Information Science degree. The award recipients shall be chosen by the dean of the College of Engineering in consultation with the Department of Computer and Information Science and the University Committee on Student Financial Aid.

It is the desire of the donor that this fund should benefit the University in perpetuity. If the need for this fund should cease to exist or so diminish as to provide unused income, then another use shall be designated by the Foundation Board in consultation with the appropriate college dean, department chairperson, or program administrative officer in order to carry out the desire of the donor.

\$25,000.00

Change in Description of Named Endowed Fund

The Clara Hilberg Teller Endowed Scholarship Fund

The Clara Hilberg Teller Endowed Scholarship Fund in the College of Humanities was established March 1, 2002, in accordance with the guidelines approved by the Board of Directors of The Ohio State University Foundation, with gifts from the estate of Clara Hilberg Teller (B.A. 1935). The description was revised on May 3, 2002.

All gifts are to be invested by the Foundation, under the rules and regulations adopted by the Foundation's Board of Directors, with the right to invest and reinvest as occasion dictates.

The annual income shall be used to provide scholarships to students who are majoring in the Humanities and who maintain a GPA of 3.0 or better. The scholarships will be awarded in consultation with the University Committee on Student Financial Aid.

It is the desire of the donor that this fund should benefit the University in perpetuity. If the need for this fund should cease to exist or so diminish as to provide unused income, then another use shall be designated by the Foundation Board as recommended to the dean of the College of Humanities in order to carry out the desire of the donor.

CREATION OF NON-ENDOWMENT INVESTMENTS POLICY

Resolution No. 2002-124

(Combination and Modification of the former Operating Fund Investments Policy
and the Total Return Operating Fund Investments Policy)

Synopsis: Revision of the University's Investments Policy is proposed.

WHEREAS the Board of Trustees, from time to time, has adopted specific policies governing various aspects of the management of the investment portfolios; and

WHEREAS there is a need for comprehensive policies to provide for the overall management of the investment portfolios; and

WHEREAS there is an opportunity to combine the Operating Fund Investments Policy and the Total Return Operating Fund Investments Policy into a comprehensive policy governing all non-endowment funds:

NOW THEREFORE

BE IT RESOLVED, That the attached Non-Endowment Investments Policy for The Ohio State University be adopted by the Board of Trustees; and

BE IT FURTHER RESOLVED, That the Treasurer be, and hereby is, directed and authorized to implement and administer this policy and to manage the Non-Endowment investment portfolio in accordance with this policy.

(See Appendix XL for background information, page 1125.)

WAIVERS OF COMPETITIVE BIDDING REQUIREMENTS

Resolution No. 2002-125

JANUARY – MARCH 2002

Synopsis: Acceptance of the quarterly report on waivers of competitive bidding requirements is proposed.

WHEREAS the Purchasing Policy of The Ohio State University adopted by the Board of Trustees on September 7, 1984, and revised on February 7, 1992, July 8, 1994, November 7, 1997, and March 1, 2002 provides that the President and/or the Vice President for Business and Finance, or for the Hospitals of the University and their related facilities, Vice President for Health Services, may grant a waiver from competitive bidding in the event of an emergency, when a sufficient economic reason exists or when the goods or services can be purchased from only a single source, with a report on such waivers to be made quarterly to this Board; and

WHEREAS the Senior Vice President for Business and Finance has submitted a report on waivers of competitive bidding requirements granted for the period of January - March 2002; and

WHEREAS during the period covered, the Senior Vice President for Business and Finance, at the requests of the departments making the purchases and upon the recommendation of the Purchasing Department, 40 granted waivers of competitive bidding requirements for annual purchases totaling approximately \$7,487,800 as shown on the enclosed exhibit:

WAIVERS OF COMPETITIVE BIDDING REQUIREMENTS (contd)

WHEREAS during the period covered, the Vice President for Health Services, at the requests of the Hospitals of the University and their related facilities making purchases, granted 38 waivers of competitive bidding requirements for annual purchases totaling approximately \$11,094,500 as shown on the enclosed exhibit:

NOW THEREFORE

BE IT RESOLVED, That the report on waivers of competitive bidding requirements for the period of January - March 2002, is hereby accepted.

(See Appendix XLI for background information, page 1131.)

**EMPLOYMENT OF ARCHITECTS/ENGINEERS AND
REQUEST FOR CONSTRUCTION BIDS**

Resolution No. 2002-126

**PAGE HALL RENOVATION
UNIVERSITY HOSPITALS EAST – EMERGENCY DEPARTMENT
RENOVATION AND EXPANSION**

Synopsis: Authorization to employ an architect/engineering firm for the University Hospitals East – Emergency Department Renovation and Expansion and request construction bids for the Page Hall Renovation and University Hospitals East – Emergency Department Renovation and Expansion projects is requested.

WHEREAS the University desires to renovate space within Page Hall that was vacated by the Fisher College of Business to house the John Glenn Institute and Public Policy and Management program; and

WHEREAS the total estimated project cost is \$16,000,000 and the total estimated construction cost is \$11,317,775, with funding provided by House Bill 640 (\$10,300,000), House Bill 850 (\$700,000), and gifts to the College of Social and Behavioral Sciences (\$5,000,000); and

WHEREAS the University desires to renovate and expand the Emergency Department space at University Hospitals East; and

WHEREAS the total estimated project cost is \$4,000,000 and the total estimated construction cost is \$3,300,000, with funding provided by University bond proceeds with debt service paid from income from patient services:

NOW THEREFORE

BE IT RESOLVED, That the President and/or Senior Vice President for Business and Finance be authorized to select qualified architectural/engineering firms as necessary for the University Hospitals East – Emergency Department Renovation and Expansion project and that the fees for these services be negotiated between the firm selected and the University; and

BE IT FURTHER RESOLVED, That the President and/or Senior Vice President for Business and Finance be authorized to request construction bids for the Page Hall Renovation and University Hospitals East – Emergency Department Renovation and Expansion projects in accordance with established University and State of Ohio procedures, and if satisfactory bids are received, to issue contracts with all actions to be reported to this Board at the appropriate time.

(See Appendix XLII for background information and maps, page 1133.)

PURCHASE OF REAL PROPERTY

Resolution No. 2002-127

252 WEST NINTH AVENUE, COLUMBUS, OHIO

Synopsis: Authorization to purchase property located at 252 West Ninth Avenue in Columbus, Ohio is proposed.

WHEREAS the Board of Trustees of The Ohio State University is presented with an opportunity to purchase the improved real property located at 252 West Ninth Avenue in Columbus, Ohio, owned by Mary Fitzgerald, at a price of \$105,000.00; and

WHEREAS the acquisition of this property is critical for the development of student housing in the south campus area, and the appropriate University offices have determined that the purchase of this property is in the best interest of the University; and

WHEREAS funding for this transaction will be provided by Student Affairs:

NOW THEREFORE

BE IT RESOLVED, That the President and/or Senior Vice President for Business and Finance be authorized, in the name of the State of Ohio for the use of The Ohio State University, to purchase from Mary Fitzgerald the improved real property located at 252 West Ninth Avenue in Columbus, Ohio, at a purchase price of \$105,000.00 and closing costs, upon such terms and conditions as are deemed to be in the best interest of the University, subject to the University receiving the necessary approvals from the Ohio Board of Regents and the State Controlling Board.

(See Appendix XLIII for background information and map, page 1137.)

REPLENISHMENT OF THE RAINY DAY FUND

Resolution No. 2002-128

Synopsis: A policy to replenish the University's Rainy Day Fund is proposed.

WHEREAS a fully funded Rainy Day Fund is critical to the financial stability of the University and the achievement of the academic plan; and

WHEREAS \$5 million of the \$10 million Rainy Day Fund was drawn down earlier in FY 2002 to address mid-year State budget cuts; and

WHEREAS General Fund units already have contributed one-time amounts of 2% and continuing amounts of 2.5 to 3.5% to support needed University budget reductions; and

WHEREAS Non-general Fund units have not yet been required to contribute to the University's budget reduction plan:

NOW THEREFORE

BE IT RESOLVED, That the attached plan to assess Non-general Fund units \$3.3 million in one-time funds to replenish the University's Rainy Day Fund be approved; and

BE IT FURTHER RESOLVED, That \$1.7 million in central uncommitted one-time funds carried over from FY 2001 also be applied to this purpose so that the Fund is restored to the previous \$10 million balance.

(See Appendix XLIV for background information, page 1139.)

UNIVERSITY HEALTH SYSTEM POLICY ON RATE ADJUSTMENTS

Resolution No. 2002-129

Synopsis: Adoption of a process for the University Health System to make rate adjustments as necessary during the year is proposed.

WHEREAS the cost of providing health care continues to increase at a rate greater than inflation and the University Health System has been very aggressive in holding down costs and rate increases over the last several years; and

WHEREAS changes in rates charged by all University areas are subject to approval by the Board of Trustees; and

WHEREAS the University Health System needs some flexibility in establishing prices to be able to respond in a timely way to market conditions; and

WHEREAS the Health System has developed a policy to permit selective rate adjustments up to 5% (excluding room rates) as necessary during the year, subject to approval by the appropriate hospital board, and with notification to the appropriate University offices:

NOW THEREFORE

BE IT RESOLVED, That the Board of Trustees hereby approves the proposed University Health System Policy on Rate Adjustments, effective immediately; and

BE IT FURTHER RESOLVED, That The Ohio State University Health System and the Office of Business and Finance shall report rate adjustments to the Fiscal Affairs Committee of the Board as appropriate during the year.

(See Appendix XLV for background information, page 1141.)

FY 2002-2003 COMPENSATION BUDGET

Resolution No. 2002-130

Synopsis: Approval of the FY 2002-2003 Compensation Budget, is proposed.

WHEREAS the current budget expires on June 30, 2002; and

WHEREAS faculty and staff salaries are significantly behind those of the University's benchmarks and other appropriate comparison groups; and

WHEREAS financial support for graduate associates is significantly behind the University's benchmarks, and we are currently in the second year of a three-year plan to contribute more financial support in the form of benefits subsidy for graduate associates; and

WHEREAS the University aspires to achieve market competitive salaries by providing salary budgets of up to 1% above comparable institutions each year for the next several years; and

WHEREAS budgeted amounts for faculty and staff salary increases at comparable institutions are projected to average 3.5% over the next 12 months:

NOW THEREFORE

FY 2002-2003 COMPENSATION BUDGET (contd)

BE IT RESOLVED, That the Board of Trustees approves budgeted increases to the salary pool in the range of 4.5% for faculty, staff and graduate associates to take effect at the beginning of Fiscal Year 2003.

Upon motion of Judge Duncan, seconded by Mrs. Davidson, the Board of Trustees adopted the foregoing resolutions by unanimous roll call vote, cast by Messrs. Brennan, Patterson, Sofia, Slane, McFerson, and Judge Duncan, Mses. Hendricks and Davidson.

--0--

APPOINTMENT AND REAPPOINTMENT OF INVESTMENT MANAGERS

Resolution No. 2002-131

Synopsis: Approval of the appointment and reappointment of investment managers is proposed.

WHEREAS it is the policy of The Ohio State University to utilize the service of external Investment Managers to assist in the management of the University's Endowment Fund; and

WHEREAS the Investments Committee of the Board of Trustees periodically reviews the results obtained by the external Investment Managers and the amount of funds assigned to each of them; and

WHEREAS it is prudent investment policy to adjust the mix and amounts of money assigned to external Investment Managers as economic conditions and performance change; and

WHEREAS the number of external Investment Managers and the amount of funds assigned to them shall be determined by the Board of Trustees:

NOW THEREFORE

BE IT RESOLVED, That upon the recommendation of the Investments Committee, the Board of Trustees hereby appoints the following named external Investment Managers and the Office of the Treasurer to manage Endowment Funds as follows:

<u>Large Cap Equity Managers</u>	<u>Market Value/ Commitment As of 3/31/02</u>	<u>Changes</u>	<u>Revised Allocation</u>
ABN AMRO	\$ 42,002,036	\$ --0--	\$ 42,002,036
Barclays S&P 500	214,355,414	--0--	214,355,414
Barclays Value Index	25,000,000	--0--	25,000,000
Nicholas Applegate Mid Cap	91,531,141	--0--	91,531,141
University Students	17,549,259	--0--	17,549,259
<u>Small Cap Equity Managers</u>			
Barclays Extended	\$152,018,880	\$ --0--	\$152,018,880
Meeder Financial	94,326,253	--0--	94,326,253
Nicholas Applegate Small Cap	27,811,949	--0--	27,811,949

APPOINTMENT AND REAPPOINTMENT OF INVESTMENT MANAGERS (contd)

<u>International Equity Managers</u>	<u>Market Value/ Commitment As of 3/31/02</u>	<u>Changes</u>	<u>Revised Allocation</u>
Barclays International	\$ 39,611,607	--0--	\$ 39,611,607
Invesco Global Asset	20,267,150	--0--	20,267,150
Sit International	13,504,088	--0--	13,504,088
<u>Fixed Income Managers</u>			
Banc One	25,456,770	--0--	25,456,770
Cypress Asset Management	23,961,088	--0--	23,961,088
Hughes Capital Management	15,113,791	--0--	15,113,791
Huntington Trust	30,723,845	--0--	30,723,845
MDL Capital Management	77,509,279	--0--	77,509,279
<u>Alternative Managers</u>			
Battelle Technology Fund	2,625,000	--0--	2,625,000
CID Seed Fund	1,000,000	--0--	1,000,000
Commonfund High Yield Bonds	15,000,000	--0--	15,000,000
Commonfund New Leaders	10,000,000	--0--	10,000,000
Commonfund Capital Partners	7,067,000	--0--	7,067,000
EDF Ventures Seed Fund	1,000,000	--0--	1,000,000
Mesirow Partnership Fund I	10,000,000	--0--	10,000,000
Ramius Fund	--0--	15,000,000	15,000,000

Upon motion of Ms. Hendricks, seconded by Mrs. Davidson, the Board of Trustees adopted the foregoing resolution with seven affirmative votes cast by Messrs. Brennan, Sofia, Slane, McFerson, and Judge Duncan, Mses. Hendricks and Davidson, and an abstention cast by Mr. Patterson.

--0--

DISTANCE EDUCATION PRESENTATION

Dr. Bobby D. Moser: [PowerPoint Presentation]

Mr. Chairman, we are pleased to be back again to give another report on the distance education operations that we have been undertaking and taking a look at the future. As you know we reported to you a few months ago on Phase I, today we will report on Phase II, and then there is actually a Phase III. As we do a little review of where we've been over the last few months with this effort, I have to give credit to our Chairman, who really challenged us to take a look at ourselves and take a look at the future.

DISTANCE EDUCATION PRESENTATION (contd)

Dr. Moser: (contd)

He always told us "Think Big" and so we have tried our best to think big with this endeavor. I have to give credit to Brad Moore, who also was on the committee, who said, "With all the expertise and knowledge we have on this campus, why can't Ohio State University become the knowledge provider of the world?" That's a tall order, but it's not out of the realm of possibility. So, with all this in mind, we're here to talk about Phase II of the Distance Education Report.

The rationale is: to serve the OSU Academic Plan; to improve access to high quality programs; to increase the effectiveness and efficiency of teaching and learning; to increase enrollments and revenue; to increase OSU's national visibility; and to stay competitive in higher education markets. The charge that we were given is three-fold: conduct an internal assessment of OSU's current e-learning offerings; recommend organizational initiatives that advance the size, scope, and effectiveness of the technology-enhanced distance and continuing education; and create an implementation plan.

Phase I was the assessment and we have completed that. We were pleasantly surprised of the activity that was already underway, and even more surprised of the interest of faculty in developing distance education-type offerings. Phase II is what we are going to report on today, which is the organizational recommendations. There are six recommendations that are in your packet of material, so we won't take time to go over those individually. There were two major outcomes from this that we will focus our time on here today. And Phase III is the implementation, which we hope to bring to you in a few months.

The first outcome that we are going to address today is the Distributive Education Support Unit. We wanted to get ourselves organized in a way that we could efficiently operate a distance and distributive education program here at The Ohio State University. Some universities set up a virtual-type university to operate their distance education offerings. We did it a little bit differently, we decided to make it an integral part of our existing academic units and we think that will serve us well. So far we think that was a good decision at that particular time. The second outcome is the OSU digital Knowledge Bank. We will explain to you a little bit later what that is all about, but it is exciting and has great possibilities, and is a big undertaking.

Let me introduce the individuals who are going to be making this presentation. First is Susan Metros, deputy CIO and executive director of Educational Technology and Distributive Learning. Susan is new to Ohio State University and we attracted her here and are very pleased to have her. She will provide some excellent leadership for us in this particular area. Karen Bruns, is the leader of OSU Cares and Outreach and Engagement, and has done a lot of work in helping this Committee move along and develop the recommendations that we are going to present here today. Ille Rhimes, CIO, is my partner in crime. It has been great to work with Ille, and he has given a lot of information and a lot of leadership to what we are doing all the way through this. Diane Daggerford, director of Academic Technology in the College of Humanities, will talk about the Knowledge Bank. So I will pass the ball right now to Susan.

Ms. Susan Metros:

Thank you, Bobby, Mr. Brennan, and Trustees. The first outcome of the Committee's report depicts a Distributive Education Support Unit designed to sustain and broaden OSU's vision for educational technologies. In bullet one, the use of the term distributive refers to the use of instructional technologies to serve both our students on campus and those at a distance. Both audiences are

DISTANCE EDUCATION PRESENTATION (contd)

Ms. Metros: (contd)

really important. For example, the majority of Web-CT use, the University's learning management system, takes place in traditional blending-learning environments. Blending meaning courses that are both online and have face-to-face components. In fact, last quarter, almost 26,000 students were enrolled in Web-CT augmented courses.

OSU has also been awarded a PEW Grant in course redesign that will support our efforts to redesign instructional approaches using technology to achieve cost savings, as well as quality enhancements. Professor Dennis Pearl is leading a team of Redesigning Introductory Statistical Concepts, a blended course enrolling over 3,200 students this year as part of the PEW Grant. OSU will implement buffet strategy offering students a choice of interchangeable paths to learn each course objective based on their learning styles.

In another blended example, the Ohio Board of Regents has funded OSU to build a curriculum in information and scientific literacy. The content will be designed as modules that can be reused in a variety of academic disciplines. The model will offer a way for Ohio institutions to share their academic content, while retaining intellectual property ownership.

Bullet two addresses the need to lay a solid foundation for an organization that will also support distance education and OSU has a really good start. Last quarter, the registrar reported 951 students enrolled in 61 courses designated as distance learning. In addition, we have 6 on-line degrees and certifications up and running. These include: the Pharm.D. degree; the undergraduate business degree for the Regional Campuses; the welding engineers master's degree; the gerontology certificate program; the master's of nursing degree; and the executive MBA degree. Furthermore, there are about 10 other programs being discussed or already under development.

So what does this organization look like? The Committee envisions an organization designed to provide the academic community with services, resources support, plus communication conduits, and collaborative opportunities for advancing and extending distributive and distance education at The Ohio State University. The organization will be comprised of four functional areas and some of these functions will reside within the new organization, while others will be collaborative efforts in partnerships with existing units within and outside the academic community.

The first functional area is technology support, which represents the infrastructure: applications, the hardware, servers, and networks. They are requisite to supporting a mission critical and scalable educational technology environment. The second functional area is instructional support, inclusive of faculty development – course design and conversion, resource management, assessment, and the research and development for future instructional strategies and technologies, including such projects as the Knowledge Bank.

The third functional area is student services, which specifically focuses on our students at a distance whose OSU experience is not predominantly physical, but virtual. We envision designing a single point of presence that seamlessly directs current and prospective distant learners to OSU's admissions, resources, technical support, and other student services.

And the fourth functional area is business services and this is a new function. It will provide access to marketing and promotion, along with business planning services. Business planning would assess the fiscal viability and return on value

DISTANCE EDUCATION PRESENTATION (contd)

Ms. Metros: (contd)

of new initiatives and offer evaluation services to our existing programs. Using MBA students as consultants, we are planning to pilot this concept with welding engineering and a potential certificate program in urban planning.

Finally, one of the most important components of this organization is the existence of the advisory committee, chaired by Bobby Moser. This committee will be composed of representatives from across the ranks of the academic communities, administration, faculty, staff, and students. The purpose of this committee will be to provide overall guidance, and to assist in drafting and reviewing policies conducive to developing and delivering new modes of technology-enhanced teaching and learning.

Ilee Rhimes, chief information officer, will continue with a description of the second outcome of The Ohio State University Knowledge Bank.

Mr. Ilee Rhimes:

Thanks, Susan. President Kirwan, Chairman Brennan, and members of the Board, the digital Knowledge Bank idea was conceived by the Distance Education Committee early in its deliberations. The concept evolved from the committee's vision for Ohio State to become the knowledge provider to the world. As Bobby indicated, that actually grew out of a comment made by Brad Moore.

The Committee reasoned that the generation, collection, indexing, and preservation of intellectual content was the most valuable University asset and would be even more valuable if it were maintained in an accessible digital Knowledge Bank. Consequently, a planning committee, chaired by Joe Branin, director of University Libraries, was formed to investigate the idea. In addition, Chemical Abstracts and OCLC were asked to participate and they each assigned an individual to the committee.

The model depicts the flow of intellectual content from all areas of the University through submission, storage, and transformation by faculty into technology-enhanced learning modules that can be delivered to students at a distance or in on-campus classrooms. These learning modules are fed back into the Knowledge Bank for others to use and build on. The model also depicts information being extracted from the Knowledge Bank by Ohio State constituents and external users and, finally, the model depicts new research findings based on extracted information being fed back as new intellectual content. Note that value added or specialized extractions could conceivably be made available on a fee basis.

In the broadest sense, the Knowledge Bank is envisioned as an enterprise-wide digital repository of intellectual content, with links to content stored in other locations. Note there are other organizations investigating and experimenting with similar concepts – most notably MIT, in partnership with Hewlett-Packard, is developing a digital repository called “D Space” to store, index, and preserve the intellectual output of MIT's faculty.

The planning committee also discovered several prototypes of the Knowledge Bank already under development by faculty at Ohio State in various academic units. One of the most interesting is the Web Media Collective. Diane Dagefoerde, director of Academic Technology for the College of Humanities, is co-director of the Web Media Collective, and she'll provide a brief overview of the collaborative project. Diane --

DISTANCE EDUCATION PRESENTATION (contd)

Ms. Diane Dagefoerde:

Thanks, Ilee. The Web Media Collective is a group of faculty, staff, and students in humanities, arts, and architecture who are working together to find cost-effective ways to make knowledge created at Ohio State available across disciplines and to audiences beyond the University.

My colleagues and I, some of whom are here today, have been developing digital collections of media assets for years; media assets being photographs, audio and video clips, CAD drawings, etc., that represent this knowledge. The Huntington Archive, for example, has been using databases to catalog its slide collection since the 1980s and the History Department has had an all-digital image and cataloging system since 1993. In 1998, the Office of the CIO funding competition was the catalyst that sparked this collaboration. In the proposal process, we realized we were struggling with the same kinds of problems, so we committed to cutting through the red tape, sharing resources, and making this work on a grass roots level.

The result? The History Multimedia Database and the Charles Csuri Archive, both currently available, the Huntington Archive, which will be released shortly, and Instructional Media Collections in humanities, history of art, and architecture, which are just entering the programming stage. These six collections alone reach over 8,000 students in 105 course sections each year. This is just the tip of the iceberg. Imagine the kind of impact we could have if we brought even 10 more collections into the system. Making these collections of media, or of knowledge, available in digital form through the Web, supports the Academic Plan and, in particular, the vision and rationale Dr. Moser just presented to you.

A colleague once showed me a photograph he had taken during his research work in India. It was in a rural village. In the center was a village house – mud walls, thatched roof – someone's home. Crossing overhead were power lines like you see in any neighborhood. The detail to be seen in the photo was that the power lines did not go to the home – it was without electricity. It was an image of rural life in India that showed how modern society is passing it by, almost ignoring its existence.

The Web Media Collective saw as a starting point the need to help faculty, students, and researchers take the media they use daily to explain or demonstrate their work and get it into a format that can be shared with this important and contextual information included. My colleagues and I sit with faculty to select images, video clips, etc., to add to these collections. We digitize them or put them in computer format and then we catalog them -- and this is the most critical step – making them accessible. Cataloging these media means they can be found by another faculty member, by a student doing a report, or by a donor interested in a subject area. And because everything is stored digitally, it can be used and reused in a variety of contexts -- Web-based versions of high demand courses, classroom presentations, research, and outreach projects, and the list goes on.

To bring this vision of knowledge provider of the world to fruition, we need to work efficiently. We need solutions that are scalable and can be implemented. The Web Media Collective has created one piece of the bank, and my colleagues and I are working diligently with faculty, students, donors, and friends, to make deposits.

There is a wealth of knowledge at Ohio State. We represent proof that this knowledge can be captured, cataloged, and shared, and that this vision of knowledge provider to the world is achievable. Thank you.

DISTANCE EDUCATION PRESENTATION (contd)

Dr. Moser:

Thank you very much for your presentations. In summary, upon acceptance of this Phase II report, we will move on to Phase III, which is implementation. Some of the things that we had looked at in the implementation plan was to prepare the plan and timetable as to what we would like to get accomplished in the next few years; identifying and aligning the resources to support the new organization and related activities; to evaluate viability of existing programs that are underway, see how we can be of help to them at the present time; and then provide business planning and viability assessment for the new initiatives that are underway.

I'd like to say a big "thank you" to the Committee. There are several members who have worked very hard on this and have spent a lot of time and put a lot of effort into it. We've still got a ways to go, but we've made great progress. Mr. Chairman, that completes our report. Thank you very much.

Mr. Brennan:

Thank you. Any questions from the Trustees? On the Knowledge Bank, there is no limit to the input to that, is there? Isn't that the key to what you were saying about how to catalog, how to store, and how to retrieve? And when you design that engine, there's no limit to what you can put into it? Is that not true?

Dr. Moser:

That's right. Once you get the framework put together, things that can be digitized can go in there. There is a wealth of knowledge that is on this campus that we could organize in a way that is useful to people.

Mr. Brennan:

Isn't your position that we're uniquely qualified to capitalize on that by the experience we have on this campus and peripheral activities going on here in Central Ohio?

Dr. Moser:

Yes, very much so. We have some interested partners from outside of the University that are willing to talk to us about this.

Mr. Brennan:

Is that collaboration going on now?

Dr. Moser:

Yes, it is. They were a part of the committee that helped develop the proposal that was sent our way.

Mr. Brennan:

Excellent.

President Kirwan:

Bobby, don't you have Chemical Abstracts and OCLC working actively with us on this?

DISTANCE EDUCATION PRESENTATION (contd)

Dr. Moser:

Yes. Both of those organizations are very much interested and worked with Joe Branin, Ilee, Brad Moore, Sally Rogers, from the Libraries, and others on this idea. So we think there's some real potential there.

Mr. Brennan:

Naturally, I can't let this last meeting go without thanking you for what you've done in this area, Bobby. When Brit appointed you chairman of the Committee, I said, "Thank God he put a competent person in charge who knows how to get things done." And that certainly is true about you. But my hot button is revenue. What are your early plans to create some revenue from all this?

Dr. Moser:

That's a good question, Mr. Chairman. I would say at this particular point there is lots of potential. We know that some of these have started and have not been successful. We want to learn from those mistakes and try to put something in place that is going to be successful. Not only good from an academic and educational standpoint, but also a potential revenue source. We think the opportunity there is great.

There is a quest in society today for knowledge – people want to learn. Sometimes those are organized curricula or courses that people want to pursue to earn a degree, other times it's professional development-type opportunities and activities to enhance themselves, and then some people just want to know about things. It's amazing to me how that is. On my own college homepage, we have 16,000-17,000 documents up on the Web. Since the first of the year, we have had on average 17,000 visitors a day.

Mr. Brennan:

And that is just Food, Agricultural, and Environmental Sciences?

Dr. Moser:

Yes. Thirty-seven thousand pages downloaded a day, on the average since the first of the year. That is up ten percent from last year.

Mr. Brennan:

There has got to be some revenue there somewhere.

Dr. Moser:

Those numbers just blow me away every time I hear them. But you are right, there has got to be some revenue in there.

Mr. Brennan:

Any more questions or comments? Dimon --

Mr. McFerson:

Bobby, is it intended and expected that all the deans and colleges are buying into this program so we won't have others doing their own thing a little differently than you are?

DISTANCE EDUCATION PRESENTATION (contd)

Dr. Moser:

We made a report to the Council of Deans and it was very well received. I think everyone's on-line. I have people coming to me and saying, "I've got an idea, where do I go with it?" I think there's lots of interest here. I think they have accepted the structure that we've developed -- a one-stop shopping. So there is one place they can go and get the assistance that they need to develop this. This is a new way of thinking, a new way of learning for most of us that grew up in academia, and so we need help.

We've got ideas and we've got great content, but not always do we know, "Is there a market out there?" We need to do a market analysis and put a business plan together so we can make sure that we're successful in revenue generation and all these things that we don't necessarily think about on a day-to-day basis as faculty members at this University. In answer to your question, I think there is interest. I think people have bought into the idea of the organizational structure that we've presented, so it is just a matter of getting it implemented now.

Mr. McFerson:

For instance, in your college, with the data that you just indicated to us, when this program is fully in place, would you be collapsing your program into this program?

Dr. Moser:

Yes, absolutely. Several colleges have Web pages now and having those networked in a way that's easily accessible -- that's the thing we've got to do, and that's what this Knowledge Bank can provide for us.

Mr. McFerson:

Thank you.

Mr. Brennan:

Yes, Ed?

Provost Edward J. Ray:

We moved quickly past the organizational structure and, obviously, how this ultimately plays out depends on the effectiveness of the implementation, but this business of "Is it organized inside or outside?" is not a matter of indifference. A number of institutions that have organized this activity outside of the mainstream of the academic enterprise have essentially set up competing organizations and have had a lot of miscommunication and conflict. I think the effort from the outset here is, in fact, to have things organized in a clear cut, transparent, effective way within the academic enterprise so that deans, chairs, faculty, and others feel that they know how to bring issues forward if there are concerns or if there are conflicts. We've got mechanisms for resolving things that happen within the existing academic enterprise. We want to take advantage of that when we bring something new like this online.

Mr. Brennan:

Which is another way of saying that this is technology transfer in a different form. We must be reasonably uniform in how we treat our internal people and how they

DISTANCE EDUCATION PRESENTATION (contd)

Mr. Brennan: (contd)

get a piece of the action. That's the challenge. The ball has been dropped everywhere. If you do that, then there could be an unlimited number of partners with whom you can associate on the outside who market however they market, but you have the inside structure firmly in place and I think that's what we're hearing here. Bobby's given me three or four examples of how this has been done elsewhere. I think not to oversimplify, but that is an unmet challenge in academia, to figure out how to turn this into a revenue for the individuals to have an incentive and to participate in a fairly uniform manner throughout the University.

I am very proud of what you've done, and I'm glad we got Phase II done before I got off the Board. I've only been on nine years and, hopefully, in another nine years you will get Phase III done.

Dr. Moser:

Mr. Chairman, for the University this has moved fast. Thank you.

(See Appendix XLVI for background information, page 1143.)

--0--

FAREWELL TO DAVID L. BRENNAN

President Kirwan:

Under normal circumstances, I know better than to interrupt you, but these are not normal circumstances, and before the meeting adjourns, I want to take this opportunity to make a little presentation to you. We want to present you with a reminder and a symbol of your service and leadership on the Board. We have an engraved box and gavel that you can use to call meetings to order in the future wherever you may be.

Mr. Brennan:

Thank you very much.

President Kirwan:

Jim, would you like to say a few words?

Mr. Patterson:

Thank you, President Kirwan. Much has been made over the years with the white hat, but the white hat to me is just a very visible symbol of David Brennan, and it does not in any way indicate the type of a man he is. I have never met anyone that has such a genuine interest in education at all levels, and the excellence of education. But to me, David, it goes even deeper than that – it's your deep passion to see that everybody has an education, as much as you can help give them or as much as they want to get – you want to make that available to them. It doesn't matter if it's higher education or secondary or the people that work for you.

I also think, speaking from a Board member's perspective, that you are a model for us all. I hardly ever remember a time that you were late for a meeting or didn't come to a meeting. I think in the eight years that I've known you, you have

FAREWELL TO DAVID L. BRENNAN (contd)

Mr. Patterson: (contd)

put being a Trustee of Ohio State first and foremost in your life. All of us as Trustees and the University owe you a great deal. Thank you very much.

Mr. Brennan:

Jim, thank you. My script says, "your farewell remarks." This isn't farewell, but it's the end of a good thing, and all good things must come to an end.

Jim, you're right. My passion is Ohio State, it is education. It's like everybody in this room – we want to help as much as God gave us the skills to help. I have made friends in this room that wouldn't have been friends, but for this experience. I've had exposure to people of extraordinary talent, extraordinary skills, throughout this University that wouldn't have happened but for this experience.

Some of you heard me say that the finest honor I ever received was being appointed to this Board. That was true nine years ago and it's true today. I'm going to deeply regret not participating at this level. At the same time, I'm a bit relieved to pass the torch on to somebody else. My fellow Trustees, those sitting here today, those I've served with before are, without exception, extraordinary people who feel just like I feel about this great University, who dedicate themselves to do the best they know how. And I'm confident that the University will continue to be in very good hands.

With all the friends and supporters that are in this room and elsewhere in the University that make us look good, it's dangerous to sort people out and say I'll name one or two or three, but I'm going to take that chance this morning. The Secretary of the Board is Bill Napier, who is in charge of the Trustees' office, but the real grunt work, if you will, was pointed out by Kevin Filiatraut. Sitting behind me are two ladies who make all of us look good and perform well. And I don't think they're recognized often enough. They are going to be uncomfortable with what I'm going to do next, but, I believe, Maureen Sharkey and Lucy Gandert deserve to be recognized by all of us for the extraordinary commitment they make to this University and to all of us. Please join me in recognizing Lucy and Maureen. I can't let that finish without pointing out that it's sort of an odyssey every meeting among the three of us sitting back here, as they try to keep me on the straight and narrow, and I forget to do things, or I insert my own words, but it's more fun that way!

There are lots of things I wanted to say this morning, but I will cut it short fairly quickly. Enormous things have happened these nine years – incredible things. The continuation of continuous improvement at this University is dynamic. Sitting on my right is, I think -- Ed, no offense to you -- the finest president this University has had. I didn't work closely enough with you, Ed, to make a true comparison, but I think it is the consensus in this country that Brit is the finest university president now sitting at any university in this country.

The four years that Brit has been with us he has given ounce for ounce, pound for pound, great value to us. We all wish more years were ahead with Brit, but none of us regret one day you've been here. This is more than friendship, this is more than admiration for skill, this is your passion, and it comes through so well. You inspire all of us. You're going to do that back in Maryland, too, damn it. But, fortunately, this is your last president's position. You're going on to some higher job in Maryland, so we can claim this as the last presidential position that you held.

FAREWELL TO DAVID L. BRENNAN (contd)

Mr. Brennan: (contd)

I can't help but point out that I have, in my nine years, gone through three potential presidential resignations. Gordon, as you might recall, did it twice. He changed his mind the first time, so, Brit, you have one coming. You may have to act pretty quickly. Jim's doing a pretty good job, but you've got one coming. If they don't treat you right in Maryland, you've got a home right here.

Finally, to my vice chairman. As many of you know, I recovered from surgery most of this year. In fact, before the surgery I look back and I probably wasn't well for quite awhile and didn't know it. So I really have spent not a very active chairman's year. Just think, Brit, how much damage I could have done if I'd been more active! But, Jim, you have been an absolute stalwart, picking up what had to be picked up when I wasn't here and, on top of the friendship that you and I have developed, that support you gave me is really, really appreciated. In varying degrees, all the rest of you have done the same thing, and I love you all. I'm going to miss you. Thank you. Jim --

Mr. Patterson:

One last bit of business and that's a lack of it. If there is no other business to come before the meeting, I declare the meeting adjourned. The next meeting of our Board will be Friday, June 7, at this location. Thank you.

--0--

Thereupon the Board adjourned to meet Friday, June 7, 2002, at The Ohio State University Longaberger Alumni House, Columbus, Ohio.

Attest:

William J. Napier
Secretary

David L. Brennan
Chairman

(APPENDIX XL)

MEMORANDUM

Date: April 23, 2002
From: James L. Nichols, Treasurer
To: William J. Shkurti, Senior Vice President for Business and Finance
Subject: Non-Endowment Investments Policy

The attached Non-Endowment Investments Policy has been created by merging and modifying the former Operating Fund Investments Policy and the Total Return Operating Fund Investments Policy. This streamlines our overall investment process and results in two policies, one for the Endowment Fund and one for Non-Endowment funds.

The modifications include several that increase dollar limits within the policy applying to various securities. This is consistent with the Endowment Fund Investment Policy. These increases are similar to the increases recently approved by the Board of Trustees in the Endowment Fund Investments Policy.

Also, wording has been added to make the policy consistent with the recently passed changes in the State of Ohio statute regarding investments by state universities. Most of these are technical changes in the statute that Ohio State has followed and long included in its investment policies and procedures.

If you have any questions or comments, please contact me.

NON-ENDOWMENT INVESTMENTS POLICY

I. Goals

It shall be the policy of The Ohio State University to manage the Non-Endowment portfolio for the use and benefit of the University in a diversified portfolio that will produce a return which when compared to the current marketplace, would be described as acceptable by conservative prudent investment managers.

II. Investment Philosophy

The Non-Endowment portfolio shall be managed with the intention of obtaining a reasonable yield, balanced with a component invested for long-term appreciation, while adhering to a prudent level of risk, and retaining sufficient liquidity to meet cash flow requirements. The portfolio shall be managed with the care, skill, prudence, and diligence under the circumstances then prevailing that a prudent person acting in a like capacity and familiar with such matters would use in the conduct of an enterprise of a like character and with like aims.

III. Definitions

For the purposes of this Policy, the Non-Endowment portfolio shall include: all registration fees, non resident tuition fees, academic fees for the support of off-campus instruction, laboratory and course fees when so assessed and collected, student health fees for the support of a student health service, all other fees, deposits, charges, receipts, and income from all or part of the students, all subsidy or other payments from state appropriations, and all other fees, deposits, charges, receipts, and income received by the University, the Ohio State University hospitals and their ancillary facilities, the Ohio agricultural research and development center, and the Ohio State University cooperative extension service. Title to these funds shall be held in trust by the Board of Trustees.

IV. Management of Investments

The Investments Committee shall meet at least quarterly. The committee shall review and recommend revision to this Policy and shall advise the Board of Trustees of the investments made under this policy in an effort to assist it in meeting its obligation as a fiduciary.

Except as provided herein, the Treasurer shall be authorized to implement and administer this Policy on behalf of the Board of Trustees and manage the Non-Endowment Portfolio in accordance with this Policy.

The Investments Committee of the Board of Trustees may retain the services of an investment advisor who meets both of the following qualifications:

1. The advisor is either:
 - a. Licensed by the division of securities under section 1701.141 of the Ohio Revised Code.
 - b. Registered with the Securities and Exchange Commission.
2. The advisor either:
 - a. Has experience in the management of investments of public funds, especially in the investment of state-government investment portfolios.
 - b. Is an eligible institution referenced in section 135.03 of the Revised Code.

V. Reporting and Accountability

The Treasurer shall be accountable to the Board of Trustees for implementing this Policy. The Treasurer shall make a quarterly written report to the Investments Committee and the Senior Vice President for Business and Finance on the status of the Non-Endowment Portfolio.

VI. Gains/Losses

It shall be permissible for the Treasurer to realize gains and losses if such an action would be consistent with the University's investment goals. Losses and gains realized on the Non-Endowment portfolio shall be charged against current income.

VII. Limitations

A. The Portfolio shall maintain a reserve of only publicly traded securities averaging at least 25 percent of the average amount of the non-endowment investment portfolio over the course of the previous fiscal year invested in securities of the United States Government or of its agencies or instrumentalities, the treasurer of state's pooled investment program, obligations of this state or any political subdivision of this state, certificates of deposit of any national bank located in this state, written repurchase agreements with any eligible Ohio financial institution that is a member of the Federal Reserve System or Federal Home Loan Bank, money market funds or bankers acceptances maturing in 270 days or less which are eligible for purchase by the Federal Reserve System.

B. Within the parameters otherwise allowed by Ohio law, the Treasurer may specify terms and conditions that are more restrictive than those of this Policy but shall not permit a less restrictive policy without specific authorization from the Board of Trustees.

C. The quality rating guidelines, which are to be used, shall be the ratings as of the date of the purchase of the security. If a rating change occurs which disqualifies a security that is already present in the Non-Endowment Portfolio, the security must be sold within ninety days from the discovery of the rating change.

VIII. Marketability

All securities purchased shall be readily marketable and meet the quality guidelines of this Policy. Investments that have no ready market that are gifts to the University shall only be accepted if it is in the best interest of the University.

IX. Authorized Investments

The following categories of investments shall be authorized for the Non-Endowment portfolio as indicated.

A. U.S. Treasury Bills, Notes and Bonds.
No limitations on amount invested or term.

B. U.S. Government Agencies
No limitations on amount invested or term.

C. Repurchase Agreements

Not to exceed \$20,000,000 with any dealer or broker recognized by the Federal Reserve as a primary dealer or any bank with assets in excess of \$5 billion and a long-term debt rating of A or better and only provided a written repo agreement is in place.

The term of any agreement shall not exceed 30 days. Collateral must be U.S. government or agency securities at 102% or more of market value of any agreement.

Collateral must be retained in an account bearing the University's name, except when there already exists a demand deposit account.

D. Reverse Repurchase Agreements

Not to exceed \$20,000,000 with a dealer or broker recognized by the Federal Reserve as a primary dealer or any bank whose long-term debt is Rated A or better and only provided a written agreement is in place. The term of any agreement shall not exceed 30 days.

E. Money Market Mutual Funds

1. Government Collateralized

There shall be no limitations on the amount invested provided it is 100% collateralized at market value by U.S. government or agency securities.

2. Other Collateral

There shall be no limitations on the amount invested provided it is 100% collateralized by marketable securities that comply with all other provisions set forth in this policy.

3. Star Ohio

There shall be no limitation on the amount invested in the treasurer of Ohio's pooled investment program.

F. Certificates of Deposit

Not to exceed \$10,000,000 in any national bank located in Ohio with assets in excess of \$5 billion and a long-term debt rating of A or better.

G. Mutual Funds, Index Funds and Separately Invested Accounts

Investment in any fund shall not exceed 10% of the total funds of the mutual or index fund. All mutual funds, index funds, and separately invested accounts shall be of investment grade, shall invest only in publicly traded securities, and shall comply with all other provisions set forth in this policy. Money market mutual funds shall not apply to this section. (See Section E).

H. Municipal or State Bonds

1. An amount not to exceed \$5,000,000 in any one municipality or state (except there shall be no limit on Ohio State University or Ohio State University-related bonds or obligations of the State of Ohio).
2. Bonds shall be rated A or better (except that there shall be no limitation on Ohio State University or Ohio State University-related bonds).
3. Bonds shall be purchased with a term less than 30 years.

I. Securities Lending

Fixed income securities not to exceed 20% of the Non-Endowment Portfolio may be loaned on condition the loan is secured. Collateral must be cash or U.S. Government or agency securities at 102% or more of market value. Lending may be done with any dealer or broker recognized by the Federal Reserve as a primary dealer or any bank whose long-term debt is Rated A or better and only provided a written agreement is in place.

J. Asset Backed Securities (ABS)

1. An amount not to exceed \$5,000,000 may be invested in any one issue unless issued directly by the Government agency where there would be no limit.
2. ABS's must be rated AAA.
3. The underlying assets must comply with all other provisions set forth in this policy.
4. ABS shall be purchased with a maturity less than 10 years and an average life less than 5 years. For maturity measurement purposes, the average life will be used.

K. Collateralized Mortgage Obligations (CMO)

1. An amount not to exceed \$5,000,000 may be invested in any one issuer except that CMO's issued directly by U.S. Government Agencies will have no limitations.
2. CMO's must be rated AAA.
3. CMO's shall be purchased with a term less than 30 years.
4. For maturity measurement purposes, the average life will be used.

L. Commercial Paper

1. Rated A-1 by Standard & Poor's and P-1 by Moody's.
2. An amount not to exceed \$5,000,000 in any corporation.
3. Commercial paper may be purchased with a term less than 270 days.

M. Banker's Acceptances

1. An amount not to exceed \$5,000,000 in any bank, or subsidiaries of that bank whose long-term debt is rated A or better.
2. Banker's acceptances shall be purchased with a term less than 270 days.

N. Corporate Bonds and Notes

1. An amount not to exceed \$5,000,000 in any corporation.
2. Bonds and Notes shall be rated BBB or better
3. Corporate bonds and notes shall have a term less than one year.

4. Foreign bonds may be purchased provided they comply with items 1 through 3 of this section and are denominated in U.S. dollars.

O. Other Investments

Between meetings of the Board of Trustees, if deemed advisable, other investments not specifically authorized by this Policy may be made if approved by the Investments Committee. Any such actions shall be taken to the Board of Trustees for approval at its next meeting.

**Waivers of Competitive Bidding Requirements
January-March 2002**

(APPENDIX XLI)

<u>Category</u>	<u>Total</u>	<u>Sole Source</u>	<u>Emergency</u>	<u>Sufficient Economic Reason</u>
Hospitals - Professional Health Care Services	\$3,379,679	\$302,475	\$0	\$3,077,204
Hospitals - Equipment and Services	\$7,714,809	\$3,228,788	\$0	\$4,486,021
Instructional and Research Equipment and Services	\$1,403,599	\$935,323	\$0	\$468,276
Administrative Support Equipment and Services	\$5,713,910	\$247,985	\$243,207	\$5,222,718
Conference Facilities	\$370,300	\$132,000	\$84,000	\$154,300
TOTAL	\$18,582,297	\$4,846,571	\$327,207	\$13,408,519

Page Hall Renovation**315-1999-189****PROJECT CAPTAIN:**

Ruth Miller, Facilities Planning & Development - Architecture, 292-4240

REQUESTING AGENCY:

Resource Planning and Institutional Analysis

PROJECT LOCATION:

0061-PAGE HALL, HENRY FOLSOM

AGE:

1902

GR. SQ. FT.:

48,125

PROJECT DESCRIPTION:

Renovation of Page Hall following relocation of College of Business to house the John Glenn Institute. It is anticipated that Public Policy and Management and Physical Facilities Shop will also be located in Page Hall.

MILESTONES:

	Projected	Revised	Actual
Arch/Eng Approved B/T	2/5/1999		2/5/1999
Bidding Approved B/T	11/1/2000	5/3/2002	
Schematic Design Approval	2/1/2001	6/5/2001	7/24/2001
Arch/Engr Contract	3/9/2000		3/9/2000
Design Development Approval	6/1/2001	12/12/2001	12/12/2001
Construction Document Approval	1/3/2002	5/6/2002	
Bid Opening	3/1/2002	7/20/2002	
Award of Contracts	7/1/2002	9/15/2002	
Construction Start	7/7/2002	9/16/2002	
Report of Award to B/T	7/1/2002	9/15/2002	
Completion	2/1/2004	4/2/2004	

FUNDING INFORMATION:

Future Capital Appropriations	\$ 10,000,000	\$ -	
HB640 Line Item Appropriation	-	10,300,000	
HB850 Line Item Appropriation	700,000	700,000	
Development-Social & Behav Sci	-	-	
Development - Academic Affairs	0	5,000,000	
Total	\$ 10,700,000	\$ 16,000,000	

USES:

% of Art	\$ -	\$ 153,000	
Construction	9,000,000	11,317,775	
Contingency	865,000	1,209,143	
Design	700,000	1,137,035	
Equipment	0	2,037,200	
State Architect	0	40,000	
Univ. Administration	135,000	105,847	
Total	\$ 10,700,000	\$ 16,000,000	

COMMENTS:

Fundraising of \$5 million anticipated for the John Glenn Institute.

Page Hall Renovation

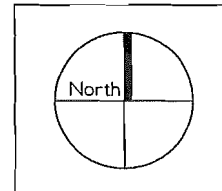
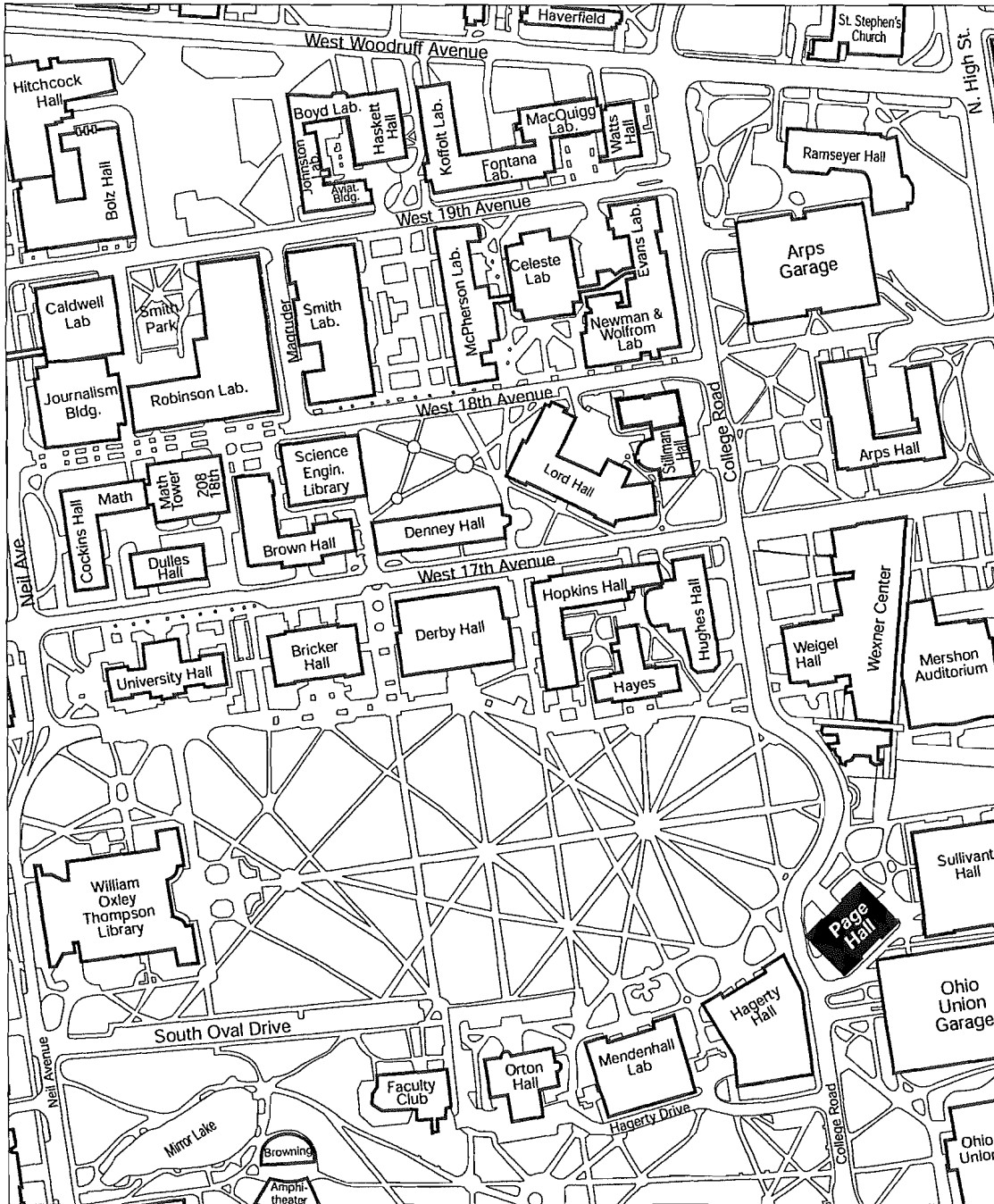

Office of Business and Finance
Office of Facilities Planning and Development

December 9, 2000

University Hospital East - Emergency Department

315-2002-915

PROJECT CAPTAIN:

Patrick Cuthbert, Office of Facilities Planning & Development, 292-3186

REQUESTING AGENCY:

University Hospitals East

PROJECT LOCATION:

0397-UNIVERSITY HOSPITALS EAST

AGE:

GR. SQ. FT.:

PROJECT DESCRIPTION:

Renovation of approximately 15,000 gross square feet to accommodate the growing number of emergency patients. This project includes the reconfiguration and upgrading of finishes and utilities in the existing space and increasing the treatment/support areas by modifying the space immediately adjacent to the existing space.

MILESTONES:

	Projected	Revised	Actual
Arch/Eng Approved B/T	5/3/2002		
Bidding Approved B/T	5/3/2002		
Arch/Eng Contract	9/30/2002		
Schematic Design Approval	12/15/2002		
Design Development Approval	3/15/2003		
Construction Document Approval	6/15/2003		
Bid Opening	7/30/2003		
Award of Contracts	9/10/2003		
Construction Start	9/15/2003		
Report of Award to B/T	11/7/2003		
Completion	4/15/2005		

FUNDING INFORMATION:

Future University Bonds	\$	4,000,000	
Total	\$	4,000,000	

USES:

Construction	\$	3,300,000	
Contingency		363,400	
Design		297,000	
Univ Administration		39,600	
Total	\$	4,000,000	

COMMENTS:

University Hospitals East - Emergency Department Renovation & Expansion

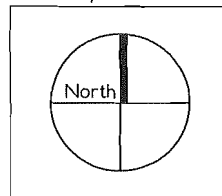
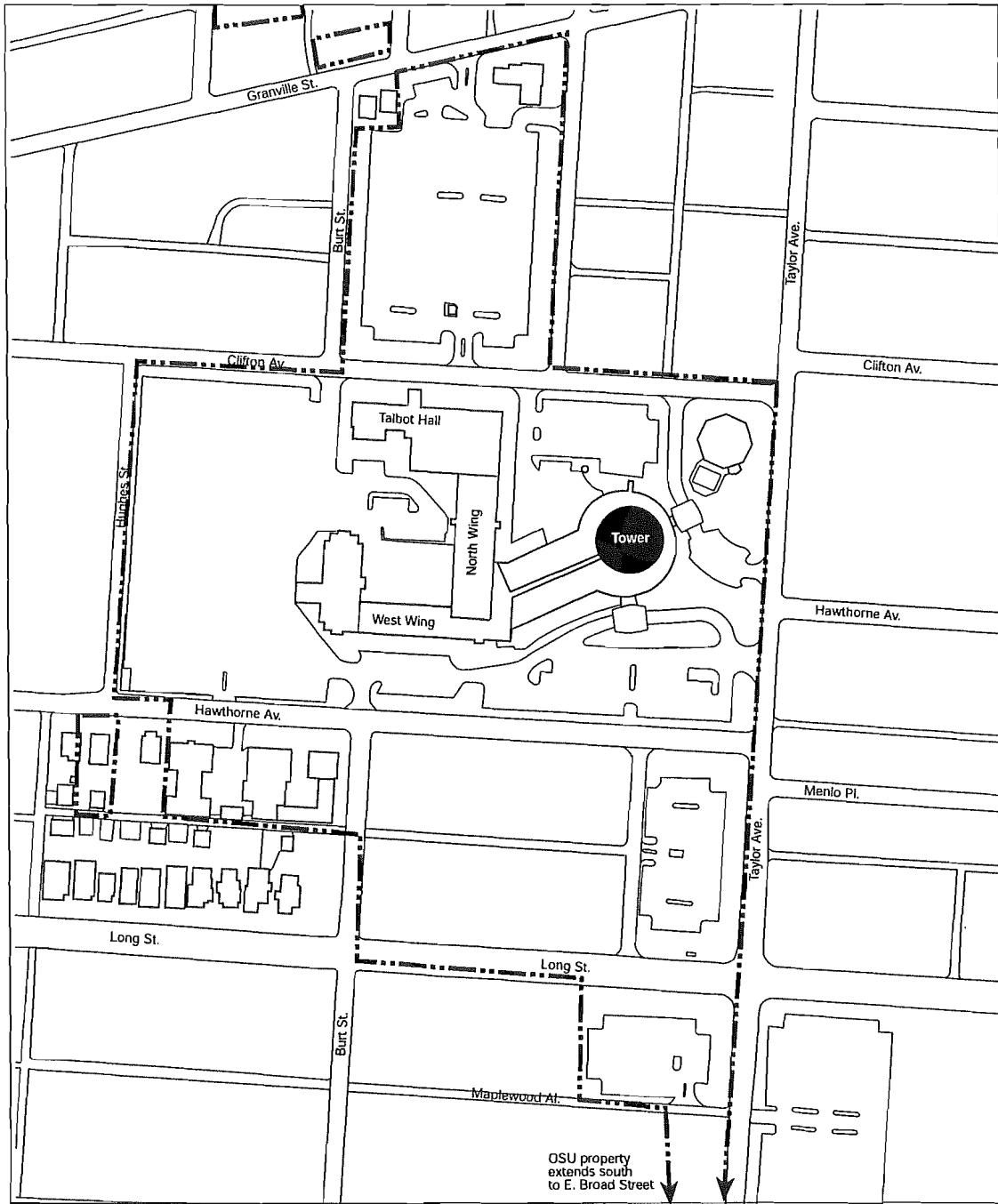

Office of Business and Finance
Office of Facilities Planning and Development

April 29, 2002

(APPENDIX XLIII)

PURCHASE OF REAL PROPERTY

252 WEST NINTH AVENUE, COLUMBUS, OHIO

Location and Description

The property to be purchased is located at 252 West Ninth Avenue in Columbus, Ohio, and is owned by Mary Fitzgerald. The property consists of a two-story frame house used as a single-family residence, situated on a city lot of 0.07 acre. The property is within the University's South Campus acquisition area and is adjacent to University property that is the site of the graduate and professional student housing project.

Appraisals and Consideration

Two MAI appraisals conducted in October 2001 by Wilhelm and Associates and R.F. Berger and Associates valued the property at \$95,000 and \$105,000, respectively. The purchase price is \$105,000.00, and Student Affairs will provide funding for the purchase.

Use of the Property

Title to the property will be taken in the name of the State of Ohio for the use of The Ohio State University. The acquisition of this property is necessary for the development of the graduate and professional student housing project.

Proposed Purchase of Real Property 252 West Ninth Avenue

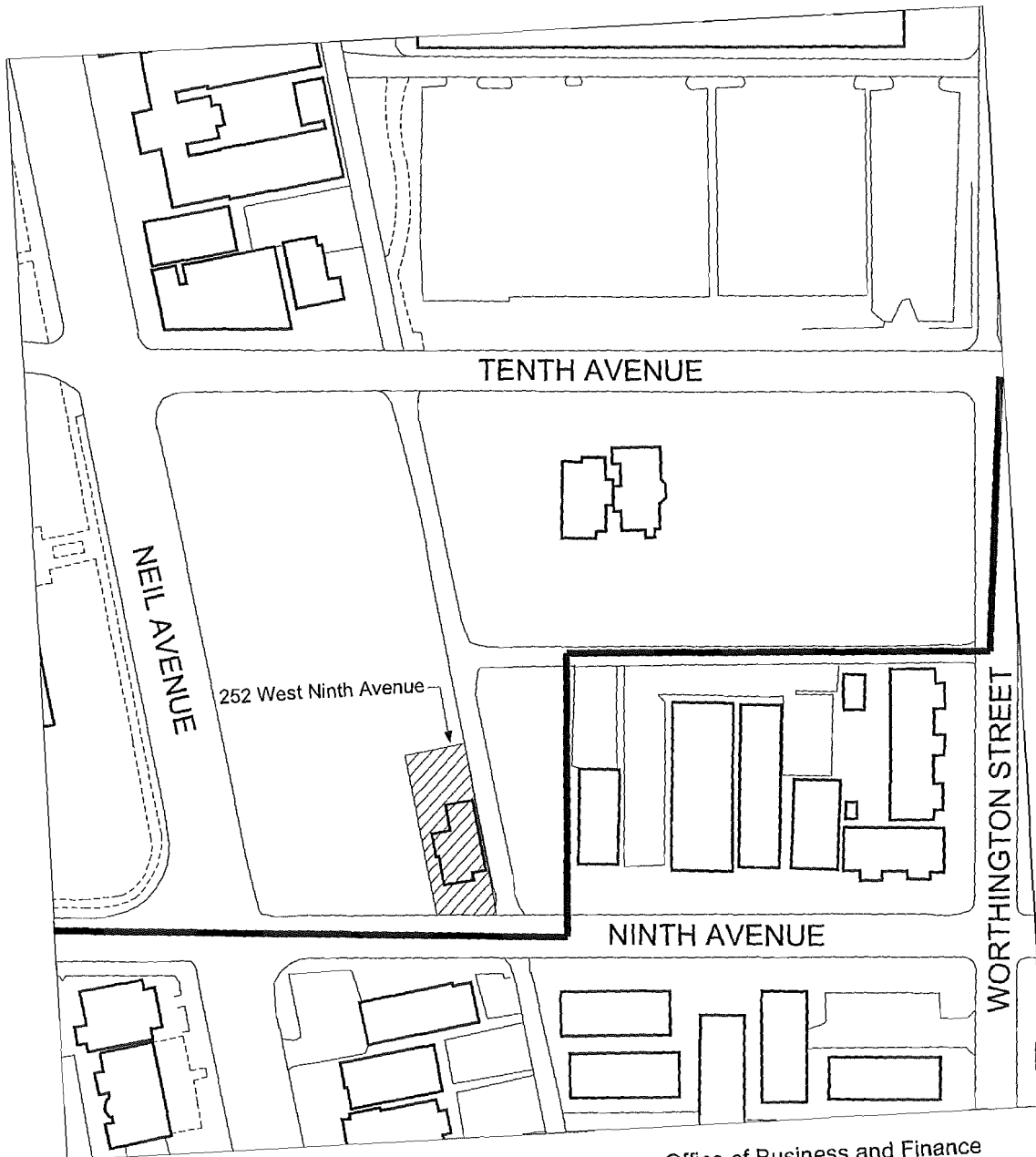

No True Scale



Office of Business and Finance
May 3, 2002



Proposed Purchase



Southern Boundary of
South Campus Acquisition Area

Map Provided by University Engineer's Office

(APPENDIX XLIV)

**Fiscal Affairs Committee
The Ohio State University Board of Trustees
May 3, 2002**

TOPIC:

Contributions from non-general fund units to replenish the Rainy Day Fund

CONTEXT:

The University's Rainy Day Fund has been drawn down to one-half its minimum desired size of \$10 million. In his October 11, 2001 Senate speech, President Kirwan pledged that non-general fund units, such as Athletics and Transportation and Parking, would make a "contribution" toward helping solve the current budget problem.

RECOMMENDATION:

- A 2% one-time assessment against all Non-general Fund units with annual revenues of \$1 million or more (see attached).
 - Based on Gross Margin (revenue less cost of sales) on actual FY 2001 expenditures.
 - Excludes University Health System's hospitals and clinics at this time. (*Note: University Hospitals is providing \$3.75M in unreimbursed space to the General Fund.*)
 - These recommendations will produce \$3.3M in one-time funds to replenish the Rainy Day Fund.
- An additional \$1.7 million in uncommitted one-time funds be reallocated centrally.
- These actions will produce the \$5 million to restore the Fund to its previous \$10 million level.

IMPLICATIONS:

- The effected units were informed in January that this was coming.
- Proposal has support of the President's Planning Cabinet.
- These are one-time funds only.

REQUESTED OF FISCAL AFFAIRS:

Approval of resolution.

Recommended Contributions of Non-General Fund Units

Unit ¹	Base ² (millions)	\$ Amount
Business and Finance		
Printing and Reprographics	\$8.8	\$175,000
Stores	3.0	61,000
Transportation and Parking	<u>12.6</u>	<u>253,000</u>
Sub Total	\$24.4	\$489,000
Student Affairs		
Residence Halls	60.7	1,214,000
Schottenstein Center	<u>10.8</u>	<u>217,000</u>
Sub Total	71.5	1,431,000
All Others		
Athletics	41.6	831,000
UNITS	11.4	229,000
University Airport	2.9	58,000
Development	<u>11.2</u>	<u>224,000</u>
Administration ³		
Sub Total	67.1	\$1,342,000
Total	\$163.0	\$3,262,000

¹ Excludes University Health System's hospitals and clinics

² Base is FY 01 Gross Margin (revenues less approved cost of sales)

³ Base is FY 01 actual revenue minus unrestricted gift money and 90-day hold. Reduction will be paid out of unrestricted gift money, not endowment.

(APPENDIX XLV)

**THE OHIO STATE UNIVERSITY HEALTH SYSTEM
POLICY ON RATE ADJUSTMENTS**

The Ohio State University Health System will implement price increases recommended by the appropriate hospital board and approved by the University administration and Board of Trustees.

This normally will occur as part of the Health System's and University's annual budget process, which includes fees/price increase considerations.

However, the Health System has a strategy, which the Hospitals Board has approved, to implement price adjustments or increases as necessary during the year.

Under this policy, selective price adjustments made during the budget year as approved by the appropriate hospital board will be reported to the University administration and the University Board of Trustees. These price adjustments/increases may be up to 5% and will exclude room rates and will be implemented in a manner that keep the Health System market competitive.

The Health System will notify the University's Senior Vice President for Business and Finance in writing, of hospital board approved price adjustments made during the fiscal year at least 30 days prior to implementation; such notification shall outline the intended impact on the operating budget of the Health System. Furthermore, the Health System will provide an updated detail list of prices, which reflects the price adjustments/increases within 30 days after being implemented.

(APPENDIX XLVI)

DRAFT

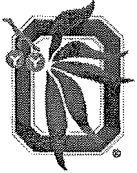

Distance Learning/Continuing Education Committee Phase 2 Interim Report



Chair: Bobby Moser, Vice President of Outreach and Engagement



May 3, 2002

Distance Learning/Continuing Education Committee Phase 2 Interim Report

Executive Summary

The Distance Learning and Continuing Education Committee, chaired by Bobby Moser, Vice President of Outreach and Engagement, was given the charge to develop a plan to move distance education (DE) forward at The Ohio State University. Phase 1 activities began in March 2001 and culminated with a presentation to The Ohio State University Board of Trustees in June 2001 and a written report in August 2001. The deliverable from Phase 1 was a proposal to create a University "Knowledge Bank" and a support unit to facilitate development of online courses, curricula, and distributive learning (DL) activities and programs at OSU. (See Attachments 1 & 2.)

A distributed learning environment is a learner-centered approach to education, which integrates a number of technologies to enable opportunities for activities and interaction in both asynchronous and synchronous, real-time modes. The model is based on blending a choice of appropriate technologies with aspects of campus-based delivery; open learning systems and distance education. The approach gives instructors the flexibility to customize both resident and remote learning environments to meet the needs of diverse student populations, while providing both high quality and cost-effective learning.

In Phase 2, the committee began to flesh out the necessary organizational, staffing, and financial requirements needed to create an organizational entity at OSU in the areas of online, distance, and distributed education. Concurrently, a subcommittee, led by Bradley Moore, V.P. for Research and Joseph Branin, Director of University Libraries was created to identify next steps in the creation of an OSU Knowledge Bank.

While the Phase 1 report offered a broad overview of DL issues, Phase 2 grappled with the state of the current DL environment in higher education and the organizational and institutional implications associated with proceeding with this activity. Generally, in the time since the initial fact finding in Spring 2001, several Research 1 universities have reduced, reorganized, or in some cases, eliminated their online distance education offerings. While online distance education activity still has significant proponents, the declining economy and reduced state budgets have made investments in this activity problematic in some universities. A tone of caution has emerged. While the market for online education still exists, the reality of the difficulties in funding, pricing, promotion, student retention, and assuring student success in online programs is more apparent.

In the original charge from the Provost, the Distance Learning and Continuing Education Committee was directed to identify a plan for advancing the size, scope, and effectiveness of technology-enhanced, distance, and continuing education.

Regarding continuing education, the committee recommended, and the Provost approved, the reorganization of the OSU Office of Continuing Education. Program development responsibilities were assigned to the V.P. of Outreach and Engagement. Advising of continuing education students was assigned to Undergraduate Student Academic Services and the conference and physical facilities activities associated with continuing education were assigned to Department of Housing, Food Services and Events.

Regarding technology-enhanced and distance education the committee concluded that while there are a number of successful online endeavors at OSU, what OSU lacks are comprehensive institutional and organizational mechanisms to facilitate the development of online distributive learning and the Knowledge Bank. The committee believes that the most direct way to develop a strategic plan for distributive learning at OSU is to address these organizational issues.

After further study of the organizational issues involved in moving forward, the Distance Learning and Continuing Education Committee adopted 6 recommendations to present to the Provost. Implementation of these recommendations should allow OSU to take the next steps in this very complex initiative. The recommendations are:

Committee Recommendation 1: The Committee advises the Provost to direct the University Registrar to work with the CIO's office and the Colleges to create a database that houses information about DE activities in various units across campus. Units participating in DE activities should report their offerings of web-based and technology enhanced courses quarterly for inclusion in a DE course inventory.

Committee Recommendation 2: The Committee advises the Provost to direct resources to the development of the OSU Digital "Knowledge Bank." The Knowledge Bank will collect, organize, maintain, and share important information about teaching and research at the University. Because lists of faculty publications, a research directory, and a repository for digital learning objects will be part of the Knowledge Bank, the Provost should direct the CIO's office and the Colleges to explore the use of a unified reporting system for faculty publications to facilitate the creation of an annual inventory of knowledge assets associated with faculty research.

Committee Recommendation 3: The Committee advises the Provost that centrally administered human and financial resources associated with distance education and distributed learning should be incorporated into a single organizational unit. The purpose of this unit would be to provide leadership and support to colleges and the university community in the areas of instructional design and technology, student services, and business planning related to DE and DL activities. Where appropriate, consideration should be given to funding these activities through a 'fee-for-service' model. The leadership of that entity should be given the charge to develop an implementation strategy for DE, complete with a business plan and identification of institutional policies and procedures necessary

to support distributed and distance education activities at OSU. (See Attachment 3 for a suggested organization chart.)

Committee Recommendation 4: The Committee advises the Provost to consider a funding model for distance and distributed education that takes a venture capital investment approach. Due to the costs and uncertainties regarding development of this activity, the central administration would provide a one-time investment in a proposed project. Investment would be competitive and would be based on evaluation of the business plan and expected net revenue return on that investment. Investments would be recouped through either direct payback from the proposing unit or through a profit sharing agreement with the proposing unit.

Committee Recommendation 5: The Committee advises the Provost to review the business plans of the 6 programs that currently represent OSU's distance education offerings before the next budget cycle. Colleges with financially viable but under-capitalized programs should be advanced additional resources in the short run.

Committee Recommendation 6: The Committee advises the Provost to appoint an Advisory Committee to revisit and finalize policy recommendations developed over the past few years regarding intellectual property and develop additional policies associated with the Knowledge Bank, Distance Education and Distributed Learning. This committee should also be charged with the responsibility of reviewing programs and projects that request central administration investment.

Implementation of the above recommendations will achieve the following:

1. OSU will create criteria for financial, strategic, and marketing evaluation of online DL proposals.
2. OSU will create and maintain an inventory of knowledge assets associated with faculty research and an inventory of learning objects associated with faculty teaching.
3. OSU will create an organizational unit that will be available to colleges and departments to assist with development of online DL proposals and the implementation of projects.
4. OSU will create a mechanism to develop, evaluate, review and advance institutional policy decisions associated with online activities.
5. OSU will create a mechanism to develop a funding model conducive to developing and delivering credit and non-credit online courses, certificates, degrees, and programs.

The Distance Learning and Continuing Education Committee believes that adoption of these recommendations will create a context in which the next steps toward creation of a significant presence in online education at OSU can be taken.

Conceptual Model: Programs and Vision

Vision: "Knowledge Provider to the World"

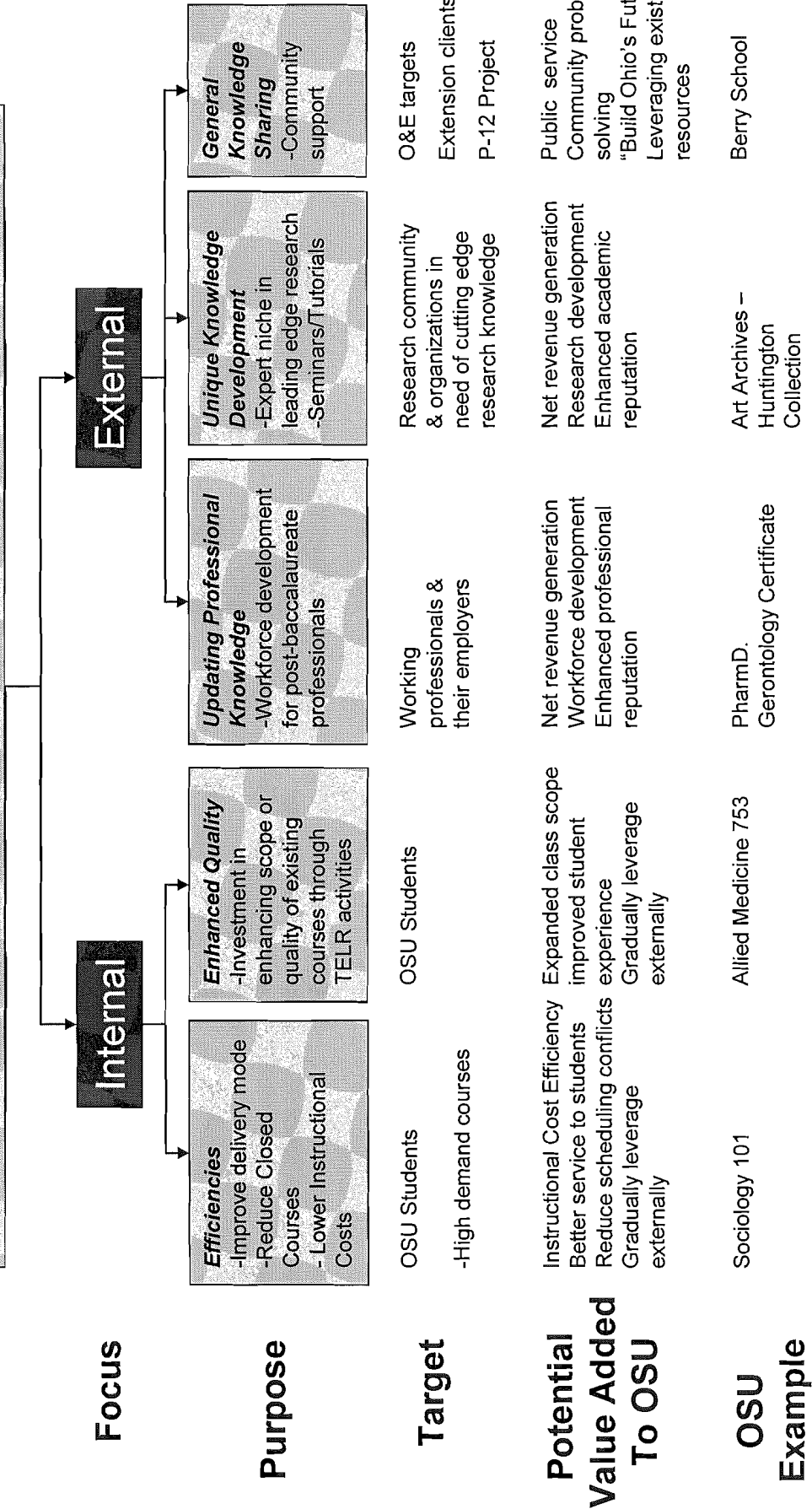

Conceptual Model: The Knowledge Bank

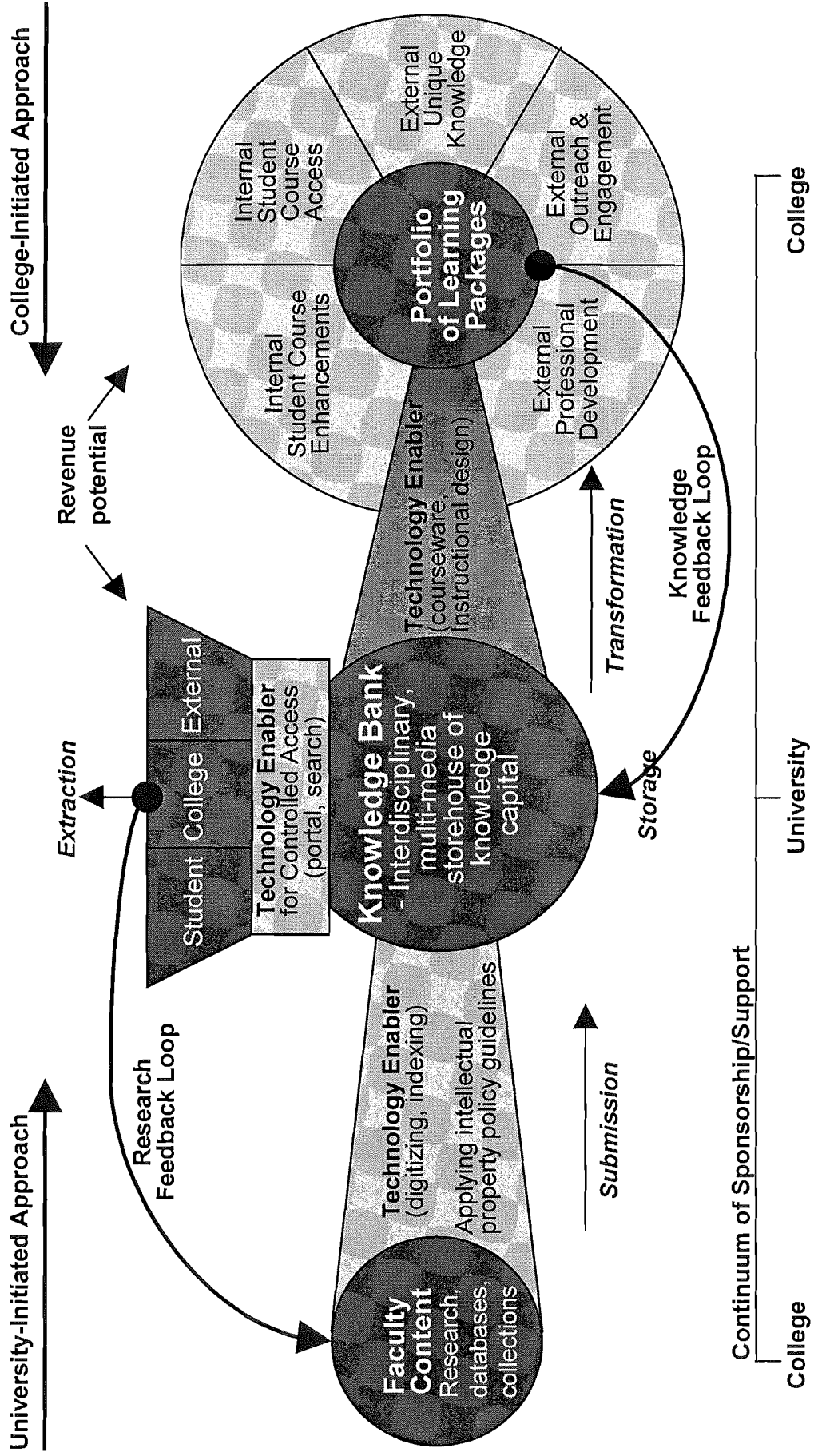

Proposed Distributed/Distance Education Organization Chart

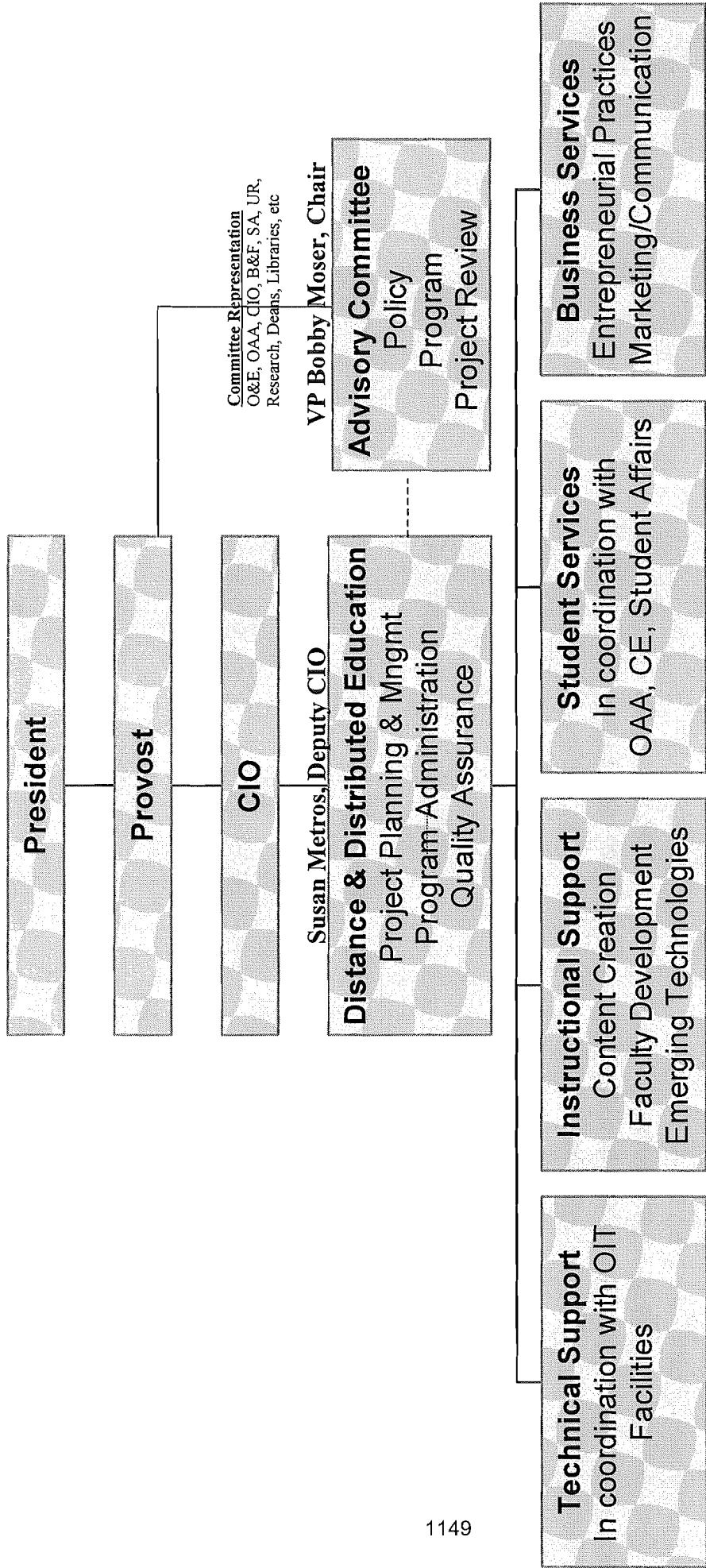

Comments:

1. Single chain of command for DE will promote greater accountability.
2. Single point of entry for customer service and support will facilitate better integration of services.
3. Advisory committee (Chaired by VP Moser) will provide DE policy, program and project review.
4. Overall approach will build on existing CIO "technology enhanced education" foundation.
5. Overall approach does not require restructuring of existing resources.
6. Structure takes advantage of Susan Metros' distributed and distance education experience and expertise.

THE OHIO STATE UNIVERSITY
OFFICIAL PROCEEDINGS OF THE
ONE THOUSAND THREE HUNDRED AND EIGHTY-THIRD MEETING
OF THE BOARD OF TRUSTEES

Columbus, Ohio, June 7, 2002

The Board of Trustees met at its regular monthly meeting on Friday, June 7, 2002, at The Ohio State University Longaberger Alumni House, Columbus, Ohio, pursuant to adjournment.

**

**

**

Minutes of the last meeting were approved.

**

**

**

June 7, 2002 meeting, Board of Trustees

The Chairman, Mr. Patterson, called the meeting of the Board of Trustees to order on June 7, 2002, at 10:00 a.m. He requested the Secretary to call the roll.

Present: James F. Patterson, Chairman, Zuheir Sofia, Tami Longaberger, Daniel M. Slane, Robert M. Duncan, Karen L. Hendricks, Dimon R. McFerson, Jo Ann Davidson, Douglas G. Borrer, Joseph A. Shultz, and Paula A. Habib.

--0--

INTRODUCTION OF NEW TRUSTEES

Mr. Patterson:

At this time, I would like to introduce our newest members of the Board and present each of them with one of our Board of Trustees pins.

Paula Habib will be a third-year medical student, and was just recently appointed by Governor Taft to succeed Kevin Filiatraut as the graduate/professional student trustee. Paula graduated from Adrian College – in Michigan, but we won't hold that against her -- and she will serve on the Board until May 2004. Welcome, Paula.

Governor Taft also appointed Douglas G. Borrer as a member of the Board. Doug Borrer is Chairman and CEO of Dominion Homes, Inc., and a 1977 alum of the University. He is active in the community, serving on the board of directors of the Huntington National Bank, Columbia Gas of Ohio, and the Capitol South Redevelopment Corp.

Doug is succeeding David Brennan, and will serve a nine-year term that expires in 2011! I wish I was starting again, Doug. This has been a great experience and you both will enjoy it. Let me present you with your pins.

Please join me in welcoming our newest Board members.

--0--

Mr. Patterson:

I also want to note for all of you in attendance that Zuheir Sofia, vice chairman of our Board, recently was recognized from his alma mater, Western Kentucky University, when they named the International Center for Zuheir, recognizing the contributions that Zuheir and his wife, Susan, have made to Western Kentucky.

Several Trustees were able to attend and be a part of that ceremony. The report back to me is that the ceremony and event went very well. Zuheir, from all of us, congratulations to you for all that you do there, as well.

I'd also like to recognize a person who I've gotten to know in the last few months – Willa Young. Willa is the outgoing chairperson of the University Staff Advisory Committee and will be ending her term and her representation here at the Board meetings, but perhaps will remain a visitor. Willa has also become an extremely valuable member of the Search Committee as we look for a new president, representing this very large, important group of staff at the University. Thank you for your help, Willa. She is not really leaving us – we're going to keep using her on the Search Committee. Thank you.

--0--

EXECUTIVE SESSION

Mr. Patterson:

At this time, I will entertain a motion to go into Executive Session to consider a personnel matter.

Upon motion of Mrs. Davidson, seconded by Ms. Longaberger, the Board of Trustees recessed into Executive Session by unanimous roll call vote, cast by Messrs. Patterson, Sofia, Slane, McFerson, Borrer, and Judge Duncan, and Mses. Longaberger, Hendricks, and Davidson.

Mr. Patterson:

The meeting of the Board of Trustees will now reconvene.

--0--

CHAIRMAN'S REPORT

Mr. Patterson:

I would like to start by reporting on the Search Committee's progress before President Kirwan presents his report. I want to update everyone on the progress of our search to recruit Ohio State's next president. I can report that the Committee is working hard, and that we are making substantial progress.

I have three specific items for the Board's consideration today. First, the Committee has retained the national executive search firm A. T. Kearney, Inc., to assist in our work. A. T. Kearney has been extremely successful in identifying and recruiting proven leaders in higher education of the caliber that we are seeking, and we believe they will bring a lot to the process.

The principle involved is a lady by the name of Jan Greenwood. We have had the opportunity to work with her and it's proving to be a good relationship.

CONTRACT TO RETAIN PRESIDENTIAL SEARCH CONSULTANT

Resolution No. 2002-132

Synopsis: Contract to retain a national search consultant to assist Presidential Search Committee is proposed.

WHEREAS the Board of Trustees has initiated a search process to identify qualified candidates for the Presidency of the University; and

WHEREAS a Search Committee has been appointed and charged with planning and directing all aspects of a comprehensive and expeditious search; and

WHEREAS it is established practice to select a professional search firm to serve as a consultant to the Search Committee and the Board of Trustees, providing advice, expertise and administrative support in the identification, screening and recruiting of the most highly qualified candidates for the Presidency; and

CONTRACT TO RETAIN PRESIDENTIAL SEARCH CONSULTANT (contd)

WHEREAS in order to identify professional search firms capable of providing the quality of services deemed desirable by the Search Committee and the Board of Trustees, a Request for Proposals was issued by the Purchasing Department of the University in accordance with established university procedures, and 6 responses were received. Following review of the proposals and selected personal interviews by the search committee, the firm of A. T. Kearney, Inc. was selected as being the most responsive and responsible in meeting the needs of the university:

NOW THEREFORE

BE IT RESOLVED, That A. T. Kearney, Inc., Dr. Jan Greenwood, Vice President, be retained as professional consultant to the Search Committee and the University to assist the search for the next President of the University; and

BE IT FURTHER RESOLVED, That any actions taken by the Search Committee or the chair in furtherance of this Resolution prior to its effective date are hereby ratified and approved.

Upon motion of Mr. McFerson, seconded by Judge Duncan, the Board of Trustees adopted the foregoing resolution by unanimous roll call vote, cast by Messrs. Patterson, Sofia, Slane, McFerson, Borrer, and Judge Duncan, Mses. Longaberger, Hendricks and Davidson.

--0--

CHAIRMAN'S REPORT (contd)

Mr. Patterson: (contd)

The next item is the *Presidential Profile*, which is a description of the qualities we seek in our next president. The document distills a great deal of thought and discussion and reflects comments made at two public forums that the Search Committee held.

As many of you know, there was a presidential profile that existed when we hired Brit. We took a look at that and we said, "Okay, is this the kind of individual that we are looking for this time." We -- being the Search Committee -- embarked upon a series of meetings wherein we met with a number of individuals and leaders of groups within the University: the provost, Development, Athletics, the President and Provost's Advisory Committee, faculty leadership, student leadership, staff leadership, Agriculture, Research, etc.; we met with public officials: Governor Taft, Representative Householder, Senator Finan, and Chancellor Chu; individuals in the community; and we even journeyed to Washington, DC, and met with the National Association of Universities and Land-Grant Colleges, and the American Council on Education to get their views.

We came back together again as a Search Committee and dealt with the presidential profile so that it was a document that we could focus on and a document that the whole of the University could claim ownership of. You will note six attributes stand out as especially important: exemplary integrity, trustworthiness, and wisdom; superb interpersonal and communicative skills; a breadth and depth of intellect; high level of energy; tenacity and judgment; and self-confidence. The profile also identifies a demonstrated record of leadership in a variety of key areas. The Committee is satisfied with this profile and requests Board approval.

PRESIDENTIAL PROFILE

Resolution No. 2002-133

Synopsis: Adoption of Presidential Profile is recommended.

WHEREAS the Board of Trustees' charge to the Search Committee included development of a profile of the qualities, skills and characteristics desired in the next President of the University; and

WHEREAS the Search Committee, in conjunction with the Board of Trustees, has sought and received input from various community and University constituencies in developing a profile statement; and

WHEREAS the profile statement will be an important element in attracting the very best candidates to seek the Presidency of The Ohio State University; and

WHEREAS the Search Committee has recommended to the Board of Trustees the adoption of the Profile of the President of The Ohio State University, in the form accompanying this Resolution:

NOW THEREFORE

BE IT RESOLVED, That the Profile of the President of the Ohio State University dated June 7, 2002, be formally adopted as the embodiment of the essential qualities, skills and characteristics desired in the next President; and

BE IT FURTHER RESOLVED, That the Profile so adopted be widely distributed and utilized by the Search Committee in fulfilling its responsibility of ultimately recommending to the Board of Trustees one or more candidates for the Presidency of the University; and

BE IT FURTHER RESOLVED, That any actions taken by the Search Committee in furtherance of this Resolution prior to its effective date are hereby ratified and approved.

Upon motion of Mr. Sofia, seconded by Mr. Borrer, the Board of Trustees adopted the foregoing resolution by unanimous voice vote.

PROFILE OF THE PRESIDENT OF THE OHIO STATE UNIVERSITY

Institutional Context

As the flagship educational institution in the state of Ohio, The Ohio State University provides uncommon value to the state, the nation, and the world. From 1870 forward, the university has set in place a foundation solidly based on excellence and leadership in public education, and it has set in motion a vision of success marked by opportunity and great expectations as we have consistently dedicated ourselves to reaching bold and exciting goals. Our assets in this process are considerable. We move forward with: a broadly embraced academic plan and diversity plan; a remarkably strong faculty, student, and staff population who are engaged in high quality work in some of the best-equipped facilities in the world; one of the largest alumni bases in the country; a strong sense of loyalty from groups internal to the university; a sense of good will from groups and individuals in the state and beyond; and an enormously successful record in private fundraising. With this momentum, the university has committed itself in a new era of growth and progress to becoming one of the top ten public institutions of higher education in the nation and to becoming an international model for what a land-grant institution can be in the 21st century.

PROFILE OF THE PRESIDENT OF THE OHIO STATE UNIVERSITY (contd)

Ohio State faces challenges, including the complex issues that exist for all publicly funded institutions. However, Ohio State operates with a vision that encourages us to be resolute in our goals and aspirations, to see challenge as opportunity, to recognize our considerable strengths, and to use them to create new paradigms for success. Ohio State seeks, therefore, a proven academic leader who shares this vision and these aspirations for excellence, relishes challenges, and embraces change as a tool for improvement and brings her or his own perspective and energy to the exciting task of enabling the university to achieve its great potential.

Personal Attributes

The Ohio State University requires a President with exceptional personal qualities, six of which stand out as critically important:

- **Exemplary integrity, trustworthiness, and wisdom.** The President must inspire trust, respect, and credibility.
- **Superb interpersonal and communicative skills.** The President must enjoy interacting with a broad range of people both within and outside the university, from students, faculty, and staff to legislators, government officials, business and community leaders, and alumni and donors throughout the world; be articulate in various settings with diverse audiences; convey persuasively a vision of research, education, and service that is capable of inspiring and motivating others.
- **Breadth and depth of intellect.** The President must be a person of extraordinary intellect and intelligence. This leader should have a demonstrated commitment to scholarly achievement and should understand scholarship from various points of view. The President should be a strategist who can see the dynamic implications of varied problems, can think beyond problems to solutions, and can understand the impact of solutions on the lives of people who will be affected by those decisions.
- **High level of energy.** The President must be endowed with great energy and a positive attitude that will inspire others to work at similar levels of intensity.
- **Tenacity and judgment.** The President must have not only a vision well-grounded in the goals and aspirations of the university, but also a strong will that will enable the implementation of those goals and aspirations in the face of competing priorities. The President must also have the will to seek counsel, to listen to and weigh advice, and to make decisions.
- **Self-confidence.** The President must possess and project the qualities of leadership required by the position of heading one of the leading public universities in the nation. This sense of self must be clear and evident, while at the same time conveying an awareness that the institution and not the person is the priority.

Areas of Demonstrated Leadership

The Ohio State University requires a President who has a demonstrated record of success in a number of areas, most notably in:

- attracting and retaining highly talented people;
- building teams in ways that produce high yield results;
- strategically managing high achievement in an environment of change;
- creating, sustaining, and enhancing diversity;

PROFILE OF THE PRESIDENT OF THE OHIO STATE UNIVERSITY (contd)

- o enabling the growth and development of internal leadership; and
- o generating resources effectively with external constituencies.

--0--

CHAIRMAN'S REPORT (contd)

Mr. Patterson: (contd)

Finally, we are recommending to the Board the appointment of an interim president to serve for an indeterminate period beginning July 1.

This is a critical time for Ohio State and for higher education in Ohio. It is important to continue our momentum and maintain our progress on the Academic Plan. We also continue to face severe fiscal challenges as a result of a weak state economy.

We are fortunate to have an ideal candidate available as our interim president. Having served as our 10th president, from 1981 until 1990, Ed Jennings not only is familiar with the University; he brings experience gained from prior budget challenges during that tenure.

Ed has remained active at the Fisher College of Business and in the community. He maintains positive relationships with many state leaders and is highly regarded by our own faculty. He will help keep us moving in a positive direction. His initiatives formed the foundation for today's march toward academic excellence. His legacy includes many items that are part of the Academic Plan, including selective investment, competitive admissions, and creating SciTech. Many major building projects took place during his tenure.

Finally, Ed is not a candidate for president, and we purposefully did not select an interim president who was a potential candidate. How long will Ed serve? We don't know. I have told him that his tenure could last anywhere from one week to several months. He said that he talked to Barbara; he'd have to rearrange his summer plans, but he was retired and he would do some of those things later.

INTERIM PRESIDENT

Resolution No. 2002-134

Synopsis: Approval of an interim president is recommended.

WHEREAS William E. Kirwan will be stepping down as president on June 30, 2002, to assume the chancellorship at the University of Maryland System; and

WHEREAS the Board of Trustees recognizes the need to appoint an interim president following his departure; and

WHEREAS Edward H. Jennings provided outstanding leadership to The Ohio State University from 1981 to 1990, serving with distinction as the University's 10th president; and

WHEREAS Edward H. Jennings made a priority of faculty recruitment and retention, thus contributing significantly to the outstanding faculty serving The Ohio State University today; and

INTERIM PRESIDENT (contd)

WHEREAS Edward H. Jennings advocated competitive admissions during his tenure as president, resulting in a significant improvement in the academic quality of the student body and the development of the Honors Program as a top University priority; and

WHEREAS the first comprehensive private capital fundraising campaign, which exceeded its goal and raised over \$450 million for University priorities, was developed and implemented during President Jennings' tenure; and

WHEREAS Edward H. Jennings has a demonstrated capability to work effectively with faculty, staff, students, public officials, donors, alumni and others to enhance the standing of The Ohio State University:

NOW THEREFORE

BE IT RESOLVED, That this Board approves the appointment of Edward H. Jennings, as Interim President of The Ohio State University, effective July 1, 2002; and

BE IT RESOLVED, That Resolution 77-92 and the provisions of the February 6, 1959 Report of the Committee on Retirement and Insurance, calling for "Principal Administrative Officials" to be relieved of their administrative assignments at age 65, be waived to allow for the appointment of Edward H. Jennings, as Interim President of The Ohio State University beyond his sixty-fifth birthday.

Upon motion of Mr. Sofia, seconded by Ms. Hendricks, the Board of Trustees adopted the foregoing resolution by unanimous roll call vote, cast by Messrs. Patterson, Sofia, Slane, McFerson, Borrer, Judge Duncan, Meses. Longaberger, Hendricks and Davidson.

--0--

CHAIRMAN'S REPORT (contd)

Mr. Patterson: (contd)

I'd like to invite Dr. Jennings to come forward and make a few remarks. Ed --

Dr. Edward H. Jennings:

Mr. Chairman and members of the Board, I'm honored and truly humbled to accept the position of interim president of The Ohio State University. The confidence in me you have expressed by this appointment is greatly appreciated and I'll do everything in my power to live up to your expectations, and, in addition, help ease the transition to the new president, which, as you said, Chairman Patterson, will not be me.

A university president, even an interim university president, will occasionally make suggestions to the Board of Trustees. This morning I have a fairly simple suggestion -- that you get on with the search process ASAP so I can get back to being retired!

During the last few weeks, several enterprising reporters have asked me whether or not, if asked, I would take the job. My answer to the reporters was, "It depended on what the Board wanted me to do." Of course, my answer dealt with the fact that your desire to continue the momentum of the Academic Plan that President Kirwan has so skillfully created and begun the implementation, is reason enough. But, in addition, that plan is completely consistent with my beliefs about the direction Ohio State University should take.

CHAIRMAN'S REPORT (contd)

Dr. Jennings: (contd)

Ohio State is truly one of our nation's great universities, but we also must adapt and change to changing circumstances so that we can better serve the State of Ohio, our student body, and, indeed, the nation. As you know, and as you noted Chairman Patterson, there are several serious challenges, not the least of which is extremely limited resources. However, I think with the world-class faculty and staff that we have, I'm confident that we're up to those challenges.

In early 1982, I gave a speech to the Ohio State family under similar circumstances. I noted then that I didn't come to Ohio to preside over the decline of Ohio State. Today, at least for a short period of time, the same holds true. Indeed, I intend to preside over the continued growth in the academic quality of our fine institution. It's true today, and will continue to be true well into the future, that this institution truly deserves the title of The Ohio State University. Everybody is probably going to get tired of hearing that.

I'd also like to take this opportunity to thank President Kirwan for his leadership. Brit, you have strengthened greatly our University and you leave a legacy that will be difficult to match. All of us have benefited, and will continue to benefit, greatly from your leadership in the many years to come. I know the entire faculty and staff are deeply grateful for your fine leadership. We're going to miss you in Columbus and in Ohio. Thank you very much from all of us.

Now, members of the Board you have a very busy agenda and I need not take any more of your valuable time. Thank you, once again, for your trust and confidence, and I look forward to working with you all.

On a personal note I'd like to introduce my wife Barbara; without her support this job could not and would not be done.

Thank you, Mr. Chairman.

Mr. Patterson:

Thank you. One final note for members of the media: Dr. Jennings will be available for questions following President Kirwan's report this morning.

To sum up the work of the Search Committee, we are on schedule and pleased with our progress. The deadline for submission of names from our advertisements, such as the *Chronicle*, is not until June 14. We are in a down period right now, but in the coming weeks we will begin to consider candidates. I remain confident that we will be successful in recruiting the kind of outstanding candidate that we believe Ohio State wants and needs.

I want to thank the Search Committee for all of their efforts and their activity so far. Believe me, it is a hard-working, dedicated group.

This concludes my remarks.

--0--

PRESIDENT'S REPORT

President William E. Kirwan:

Mr. Chairman and members of the Board of Trustees, I would like to begin by congratulating both the Board for its wisdom in appointing Ed Jennings as interim president and Ed for his selection.

I have known and admired Ed Jennings for a long time, starting when he was president of The Ohio State University and I was provost at the University of Maryland. I remember back then that he was one of the presidents I most admired. We all know that Ed is a tremendous leader; as evidence of that, let me note that so much of what we are doing today we owe to his vision for this wonderful University and his leadership in starting it down the path we follow today.

In the three weeks ahead, I am eager to be as helpful as possible to Ed, and to do my best to provide for a smooth transition. Ed has been a good friend and a wise counselor to me during my tenure and I want to do all I can to support him as he prepares to assume duties as interim president.

In my final report to you today, I would like to comment on two subjects: the status of the Academic Plan; and a few observations on the future.

Since the development and implementation of the Plan has been the main focus of my energies as president, it is fitting that my final report to you coincides with the first annual report on the Academic Plan. When we developed the Plan, we committed to you that we would also develop benchmarks against the nation's best public universities and report to you and the community annually on the progress toward the goals of the Plan against these benchmarks.

The first annual report has just been completed and will be distributed to you later today. While not all of the Plan's six strategies and 14 initiatives are resource-intensive, many of them are, and as we know all too well, that became a major obstacle to our progress. Not only did we not experience the growth in state funding we advocated, our budget was actually reduced six percent. Many institutions would have put their plans on hold at that point, throwing up their hands and throwing in the towel. But not, I am proud to say, the faculty, staff, friends, or the Trustees of The Ohio State University. Instead, we accepted the challenge to do the best we could with the resources we had. Thanks to the Plan, we were able to focus our efforts and make meaningful progress in areas important to the Plan's goals.

As you will recall, we chose to target our limited resources this year on four current areas of focus: 1) compensation for faculty and staff; 2) an enhanced educational experience for our students; 3) creation of an Institute for the Study of Race and Ethnicity in the Americas; and 4) a Biomedical Research Initiative.

I am pleased to report that we have made meaningful progress on all four of these priorities and on other aspects of our Academic Plan generally. We have reported to you at recent meetings on our success in regard to enhancing undergraduate education where, for example, ACT scores have risen from 22.8 to 25.2, and retention rates have increased by ten percentage points over the past five years. I've reported as well on the creation of the Institute for the Study of Race and Ethnicity and the appointment of an eminent scholar, John Powell, to lead it; and on our Biomedical Research Initiative, led so effectively by Fred Sanfilippo. This morning I will bring you up-to-date on the compensation initiative.

PRESIDENT'S REPORT (contd)

President Kirwan: (contd)

Compensation was a primary focus because we have fallen behind our competition. We all know that academic excellence requires competitively compensated faculty, staff, and graduate students. So we committed to develop a strategy to begin winning back the ground we had lost to other institutions, but there was a rub – we would have to do it with money we generated ourselves, since the state was unable to provide adequate support.

As a mid-term goal or first step, we made it our top priority to reach the median salary level of our benchmark universities for faculty and of established comparison organizations for staff and graduate students within the next three or four years. Our Plan was developed through consultation with a Competitive Compensation Oversight Group that included representatives of the faculty, staff, and students, and key members of the Senate and administration.

As you know, our goal for the upcoming year was an average salary increase of 4.5 percent for faculty – one percent above our benchmark peers, or at least our estimate of where the benchmark peers would be. Now that the chairs, deans, and vice presidents have completed their salary allocations, I can report that we have achieved that 4.5 percent goal and in many cases exceeded it. Each college and academic support unit will communicate these increases to faculty and staff over the next month, and we will publish a statistical report in the near future as well.

As a group, the faculty has the highest average increase, 4.8 percent, which exceeds the average increases for deans and vice presidents. Staff are not far behind at 4.6 percent, and classified and unclassified staff averages are virtually the same. What's more, over 80 percent of the faculty and of each staff group received an individual increase of at least 3.5 percent. While these results vary to some extent from college to college and unit to unit due to differences in market position and the ability to free up funds, no unit averages are below 4.3 percent.

Earlier this week, I attended the semi-annual meeting of the Big Ten presidents. As usually happens at our June meeting, we went around the table reporting on our salary increases. No Big Ten president at the meeting, except for me, reported an increase in excess of 4 percent, and several reported no increases at all. Clearly, we have made progress this year.

Let me extend my appreciation to the provost, and to each dean, vice president, and department chair for these very meaningful results. The compensation initiative is off to a good start, and I know that everyone here will remain committed to it in the future years.

While I do not have the time today to review them all, we have made meaningful progress on many other elements of the Academic Plan as well. For example: we have garnered four of seven new Ohio Eminent Scholar positions; this year we have recruited two National Academy members; a MacArthur winner to our College of the Arts; and several highly distinguished, internationally recognized faculty in the Colleges of Humanities, Social and Behavioral Sciences, Law, Medicine, and other colleges.

Speaking about our distinguished faculty recruits, I want to interject an example of the extraordinary quality of our present faculty – two members of our faculty have just made a startling discovery that has captured the attention of the world's scientific community. Michael Chan and Joseph Krzycki found the 22nd amino acid. The 21st amino acid was discovered in the mid-80s, and no one had any

PRESIDENT'S REPORT (contd)

President Kirwan: (contd)

reason to believe other amino acids existed. This is an especially important discovery because amino acids are the building blocks of life and this is a research discovery that has startled the scientific community worldwide.

Returning to the year's activities with regard to the Plan, we have: almost completed demolition to prepare the way for groundbreaking on our Campus Partners Gateway project; begun the planning phase and launched a major fundraising campaign to support a complete renovation and renaissance of the Thompson Library, and recently secured three major seven-figure gifts for this project; held groundbreakings for the new physics and architecture buildings, and for the Ross Heart Hospital; completed SciTech's Science Village Phase One; and have made encouraging progress in our Diversity Action Plan. I think you will agree by any standard that this is substantial progress, and we've done this in a time of highly constrained resources. This is a great credit to the entire community for its dedication to the advancement of academic excellence at Ohio State.

As I mentioned a moment ago, we will provide copies to you this morning of a report highlighting all of our progress in more detail, which is also posted on the University web site.

I would like to add one important additional perspective on the Academic Plan. From my vantage point, the Plan's greatest impact is not the specific accomplishments I have highlighted, although they are very important. The greater impact, I believe, comes in two other ways. First, the focus and discipline of the Plan allowed us to make substantial progress at a time of incredibly restrained resources. Without such a disciplined way to target resources, we would have been much less successful. Second, the Plan helped create broad acceptance for our vision inside and outside the University. Over the past two decades, a debate has pitted two opposing visions of Ohio State against one another. Were we to be the university that focused on size and tried to accommodate everyone knocking on our doors, or were we to be the nationally recognized, top-tier university that Ohio has heretofore lacked?

Today, thanks to the efforts begun by Ed Jennings and continued by Gordon Gee, and with what we have been able to accomplish over the past four years, I think that debate is over. This is a University that is now on a trajectory to realize the aspirations of the Academic Plan and enter the ranks of the nation's very best teaching and research universities.

The broad acceptance of the Plan in articulating the University's aspirations, was, ironically, confirmed for me on the day I announced my decision to step down as president. On that day, the Trustees issued a press release saying that you would seek a president who would continue to pursue the goals of the Academic Plan. And, the *Lantern*, that great source of information and opinion -- and, I'm proud to say, a prize-winning student newspaper -- also called for the selection of a new president who would be committed to achieving the goals of the Academic Plan. The expression of support for the goals of the Academic Plan, coming from the Trustees on the one hand and the student newspaper on the other, indicates to me that the Academic Plan has truly become a rallying cry for the greatness, the overwhelming majority in this community strives to achieve. For me, that is perhaps the Plan's most important contribution.

As we look to the future, it is clear that the State of Ohio faces severe financial challenges over the next several years, and this means the University will too. In order to maintain its impressive momentum, the University must continue to

PRESIDENT'S REPORT (contd)

President Kirwan: (contd)

exercise considerable focus and discipline. The Academic Plan will help, but difficult decisions will need to be made about how resources can be optimized to advance the academic mission.

I leave very optimistic about the future of this University, but it must be willing to change and evolve. I urge that, in the future, not just our resources and quality indicators, but also our ability to make decisions and redirect resources be benchmarked against the nation's best universities. The University and its supporters also need to keep the pressure on our state government to do better by higher education. And we will need to follow through on the second year of our two-tiered tuition plan.

You will recall that we agreed a few months ago to phase in our surcharge on entering students over two years, rather than implement it all in one year, as we had originally planned to do. When we first introduced our tuition plan, Ohio State became the focal point for a statewide debate on college and university tuitions. Questions were raised on and off campus about our plan to aggressively raise tuition for new students. Now, the smoke has cleared; the numbers are in, and guess what? Our position relative to other Ohio public universities and colleges has not changed for new students and has actually fallen for continuing students!

We now know that when you compare tuition from the Autumn Quarter of 2001 with the Autumn Quarter of 2002, you find the following: 1) our nine percent increase for continuing students was well below the average of 14 percent at Ohio's 13 state universities. In fact, only one school raised its tuition less than we did for continuing students, and that was eight percent at Central State. 2) In dollar terms, we now rank 9th for continuing students, just behind Cleveland State. Last year, we ranked 8th. 3) Now let's look at new students, where we increased tuition by 19 percent. Our increase ranked 5th among the 13 Ohio schools – only 5th, for which the average increase was 17.3 percent. 4) In dollar terms, we now rank 8th for new students – precisely where we were a year ago, behind Miami, Cincinnati, Bowling Green, Kent State, Ohio University, Akron, and Toledo. All of these schools have higher tuitions for new students than does Ohio's flagship university. If we had implemented the plan as originally proposed, we would now rank 6th in tuition for new students, behind Miami University, the University of Cincinnati, Bowling Green, Kent State, and Ohio University.

We can agree that it would be better if tuition increases could be avoided. At the same time, given our circumstances and unless something miraculous happens with Ohio's economy, there appears no reason not to implement the remainder of our tuition plan for next year, and I urge the Trustees to do so.

In conclusion, let me say what an honor and privilege it has been to serve as president of The Ohio State University. The past four years have been perhaps the most exhilarating and meaningful period of my life. I am deeply appreciative of the support and friendship that has been extended to me by the Trustees and the campus community generally. While at one level you are my bosses, you have also become my friends.

This is a great institution and it is so because it is made up of talented, caring, and dedicated people such as those in this room. I may depart physically on June 30, but I will always feel as though part of me is still at Ohio State. I will watch with great interest as this University moves forward in the years ahead. I also plan to return periodically to visit the many friends I have made here and to

PRESIDENT'S REPORT (contd)

President Kirwan: (contd)

savor the special spirit that characterizes The Ohio State University. I will always look back on my time here with great pride and a genuine sense of nostalgia for what I leave behind. I express my heartfelt thanks, deepest appreciation, and very best wishes to each and every one of you.

Let me simply close with what has now become my favorite refrain: Go Bucks! Thank you very much.

(See Appendix XLVII for the Academic Plan – First Year Report, page 1223.)

--0--

**STATUS REPORT ON THE PRESIDENTIAL COMMISSION
ON THE REGIONAL CAMPUSES**

Mr. Patterson:

One of the initiatives that Brit undertook some months ago was the creation of a Regional Campus Commission, to look at the role of the regional campuses in Ohio State's future. I've had the opportunity, along with Karen Hendricks, to serve on that Commission and be a part of it.

I don't know what our original time frame was, but we found as we went into this that there was a huge question and there were many issues within it that should and needed to be addressed. I can testify to you that the Commission that we had working on this was diligent and effective. I think they're coming up with a good report. There has been a tremendous amount of work. As I personally see it, I think the study of the regional campuses is key to the Academic Plan. It has to do with access, and some of those questions that Brit raised.

The chair of the Commission is Bobby Moser, vice president for Food, Agricultural, and Environmental Sciences, and Outreach and Engagement. I would like to call on Bobby for a presentation of a status report on the plan.

Dr. Bobby D. Moser:

Thank you, Mr. Chairman and members of the Board. It is a pleasure to be able to bring what we hope to be our final report on the Regional Campus Commission. I have with me Randy Smith, vice provost, who will also help me with this report.

I think you have in your folders a three or four-page summary that we will follow to give you the highlights of our recommendations. I would like to add to what Chairman Patterson said about this Commission being a very active and working commission. It has been very dedicated in its effort and we have spent a lot of time. Dr. Kirwan appointed this Commission about this time last year, so we've been working diligently trying to come up with some recommendations. And, yes, we did get into some interesting kinds of questions that were asked and, hopefully, we've tried to come to closure on many of those questions.

There were 17 members on the Commission and those members represented the faculty, both from the Columbus Campus and the four regional campuses, as well as students, staff, and administration. There were also three Trustees on the Commission: Jim Patterson and Karen Hendricks of this Board, and Tom Brannon of the Newark Board.

**STATUS REPORT ON THE PRESIDENTIAL COMMISSION
ON THE REGIONAL CAMPUSES (contd)**

Dr. Moser: (contd)

We have committed ourselves to several activities and one of the first things that we did was to take a look and review the Academic Plan. We wanted to see how the regional campuses could fit and make a contribution toward helping this University fulfill its Academic Plan. That will become a part of our recommendations that Randy will give to us here in just a minute.

We visited two other universities that have regional campuses similar to what we have – Penn State University and South Carolina University – and we learned a lot from those visits, and used that in our deliberations as we went about our work. At the beginning of the process, we held visits at the regional campuses where we heard from faculty, staff, and community leaders in terms of what they were seeing as the concerns and issues that we need to be addressing. Then, of course, we finished up just within the last two weeks with visits back to the regional campuses to give them a briefing of what our progress has been to this particular date.

We also visited with Garry Walters, vice chancellor of the Board of Regents, to get his perspective and the Regents' perspective on the regional campuses, and we met with three of the co-located technical college presidents to hear their perspective. We met with the University Staff Advisory Committee and had a discussion with them on the campuses, which represented not only this campus, but also the regional campuses. We also met with the deans from the three campuses and the president of the Newark Campus to hear their perspective on the regional campuses and what they saw as some issues that we need to be addressing as well. And, lastly, we met with the Arts and Sciences deans and the dean of Education, because they are the colleges that are most engaged in the regional campus efforts. So we had some good input from those people as well.

Before I turn it over to Randy for the recommendations, I want to mention that we had divided ourselves up into four major subcommittees: 1) the Mission/Governance Committee, chaired by Karen Hendricks; 2) the Admissions/Enrollment Committee, chaired by Jim Mager; 3) the Students/Student Services Committee, chaired by Diane Whitbeck; and 4) the Faculty/Curriculum Committee, chaired by Rich Petty. So the recommendations that you're going to be hearing from us will be organized around those four major subcommittees.

There is one major statement or one overarching theme that we thought was very important and a point to make up front. That is, as we looked at our regional campus system and how it really contributed toward us meeting and fulfilling our Academic Plan, we felt like we needed to have a one-university system. We asked ourselves a question, "Are we a one-university system with many different locations and many different learning opportunities, or are we a federation of campuses?" We came to the conclusion that we are one university with many different locations and many different learning opportunities. So our recommendation that you will hear will be built around that particular theme.

So let me turn it over to Randy now to give you the details of the recommendations, and then we'll open it up for questions.

Dr. Randy Smith:

Thank you and good morning. In addition to the four of us around the table who are members of the Commission, we also have with us today Dean Bob Gold,

**STATUS REPORT ON THE PRESIDENTIAL COMMISSION
ON THE REGIONAL CAMPUSES (contd)**

Dr. Smith: (contd)

from Mathematical and Physical Sciences; Jim Mager, from Enrollment Services; and Diane Whitbeck. So three other members of the Commission are here and can respond if need be.

Let me stress at the outset that this is an overview of a document that is about to come out later in June, so we're really just dealing with the major highlights of the recommendations and issues around them. Let me also stress that what the document is not is a document that deals specifically with issues of a particular campus -- this is the regional campuses as a set of locations. So, I wanted to make those qualifying comments right up front.

What I'm going to do is briefly work my way through these bulleted points that you have, and then we can open it up more broadly for questions.

One of the things that is clear and became clearer to those of us on the Commission who are not members of the regional campuses ourselves -- and certainly those of us in Columbus who interact with them in some way -- is that the regional campuses, their roles, and their characteristics are not well understood by most members of the total University community. So right up front in our document, there are going to be two major points made.

The first point is the need to clarify why we need regional campuses as part of the University, and at least four issues are stressed there: 1) access -- Mr. Patterson alluded to that a few minutes ago -- to Ohio citizens who otherwise might be unserved, and other categories; 2) extending Ohio State's geographic presence more formally throughout the state; 3) enhancing economic development -- if we're indicating that the University is an engine of economic development, that should be the case at each of its locations; and 4) through outreach and engagement activities, strengthening the learning opportunities within those communities.

So this document, we think, will right up front indicate to those who are less familiar with the regional campuses what those roles are. I might point out that in the report -- because this will receive widespread distribution -- there will be a fairly detailed description of the regional campuses -- the faculty, students, staff -- and the characteristics that they have.

The second broad point is -- which Bob just alluded to -- the need to adhere to -- we have been along the path of a one-university-in-many-locations route in recent years, particularly, and that does need to be stressed, and I'll come back to it in a few minutes. But we also note that among these locations we do need to work on stronger, internal system characteristics and again I'll allude to that in a few minutes. Nonetheless, those two major points will be addressed right up front in the report.

In terms of the response to the charge from the President, as Bob mentioned we divided the group into four subcommittees, and so let me go through each subcommittee. The first subcommittee was Mission/Governance, and Karen was the chair of this committee. Three major issues or topical areas emerged here. Regional campuses are a part of the University and as such they share the vision, purpose, core values, and future. So this group is going to suggest that we look at the University's Vision Statement, which sits right up front in the Academic Plan, and make some revisions to it. This will highlight the role of the regional campuses, particularly at various points indicating that the University at all of its locations, or alluding to specific things at the regional campuses

**STATUS REPORT ON THE PRESIDENTIAL COMMISSION
ON THE REGIONAL CAMPUSES (contd)**

Dr. Smith: (contd)

themselves, contribute to that. So one of the recommendations will be to revise the Vision Statement, highlighting that role for those campuses.

The second issue had to do with governance. All of the campuses operate from a common set of bylaws for the Regional Campus Boards of Trustees and we are suggesting here that some fine-tuning be done, more specificity regarding authority and delegation. So this suggests that we'd be coming back and asking for minor revisions to the bylaws of the Regional Campus Boards of Trustees to give a more structured nomination and selection process, and a variety of other topical areas that you see listed here. At the last Board meeting, a special committee of this Board was established relating to the regional campuses, so that fits with that major recommendation.

The third issue – this is an important issue to the regional campuses -- I mentioned earlier the notion of thinking more in “systems” terms. We have Columbus and the four regional campuses, and we want to be thinking more systemically within that set. In some areas, we know that, in fact, systems thinking and operations really do work.

For example, in personnel matters with regard to hiring and promotion and tenure of faculty, we function as a system. Increasingly, in things like advising, we function as a system as well, but there are other areas where we do need improvements. Whether it's linkages with Student Affairs or on business-related matters, the argument here is that we need to tighten those things up. And that shows up in terms of how we might make this work, certainly through the Provost's Office.

So the major recommendation here is that the executive vice president and provost should review the current pattern of interactions between the vice provosts who have specific responsibilities for the regional campuses and determine how we might improve coordination. I can elaborate on that a little bit more fully later if need be, but let me say that if that actually happens, it's not a question of any interference with the linkages between the dean/directors of the regional campuses and the provost – direct access would still be maintained. So, under the mission and governance topic, three of the big picture topics are the ones that I just mentioned.

Admissions/Enrollment is an area where there have been quite a few concerns and certainly a lot of interest in recent years. Jim Mager chaired this subcommittee, and Jim Patterson and I sat with this group throughout its process. There are four or five major issues here and Jim Mager is with us if we need to elaborate more fully.

The first issue relates to the current application process – students who applied to The Ohio State University in what locations they're interested. Our suggestion is that beginning with the Class of 2003 -- that is a year from now – that students be asked to indicate both a first choice and an alternate choice on the application process. Then that would be followed up with a letter that would be developed by the regional campuses working with Undergraduate Admissions to indicate to the students then what the result of that application process has been – these two things go together. A lot of people have been asking for this for some period of time and the Commission has brought it forward more formally.

The second issue is the campus change policy. We're not talking about transfer here. We don't use the word “transfer” from the regional campuses because they

**STATUS REPORT ON THE PRESIDENTIAL COMMISSION
ON THE REGIONAL CAMPUSES (contd)**

Dr. Smith: (contd)

are part of the University already. But in terms of campus change policy, we're suggesting moving from the current 30 credit hours requirement to 45 credit hours before changing campuses. Research shows that the longer the period of time at this first location, the more likely for success at the Columbus Campus.

The third issue has to deal with – and this is certainly beyond where we are now - - if we get to the point where resources are such at regional campuses where we are dealing with admission policies, then we really need to have some principles around which we deal with this topic. This, again, would be down the road. But in the long run, if there are demands for academic resources for which there are challenges, then we need to have priorities that guide them, including open admissions as a first step. Open admission for Ohio residents is the dominant one there.

One of the issues that we looked at in considerable depth in this process was advising. If you're a student on a regional campus and you are interested in a particular major that is or is not available there, to what extent are you advised in terms of the steps to come to Columbus? That appears to be working very well now, and all we are suggesting here is that the advising system continue to work in OSU system terms, because it's a good example of how it can work. But one of the things we would suggest is that there be efforts to follow-up, in a more systematic way, with the students who have moved to Columbus. For those students who have been at Marion or at Newark and who come to Columbus, we need to do a more detailed look at how that process went for them. We can then use that information to help guide future students.

We certainly do need -- and I won't do justice to this in the short time -- to develop a consistent message in marketing and recruiting efforts relating to the regional campuses. Work is already underway on this topic through Jim's office and others. We are really talking about -- effective with the incoming class for 2003 -- a description of the University system of campuses becoming standard in all of our recruitment presentations, publications, and other marketing communications. This would refer to all campuses as opposed to just one, but at the same time, not interfering with any particular form of marketing or recruiting an individual regional campus might want to develop.

Then – and I know some of us feel strongly about this – the need to develop for the regional campuses -- in ways that are similar to what we have certainly for Columbus -- a more sophisticated enrollment projection process for those campuses. Again, Jim can elaborate on that if need be.

So, quite a few areas under the Admissions/Enrollment topic were dealt with and confronted. Again, as we visited the campuses, these are ones that these campuses feel quite strongly about.

Related to that is Student/Student Services, chaired by Diane Whitbeck, and there are two major points here. As you know, the discussion of student housing on the regional campuses has been forefront in the last year or so, and there was a lot of discussion about this and alternative ways of proceeding. What was suggested is that the University adopts the OSU-owned and managed approach to student housing on the regional campuses. We have expertise in this area, we know how to do it, and we know how to establish facilities that take the student and student needs in mind. So that approach is being advocated.

**STATUS REPORT ON THE PRESIDENTIAL COMMISSION
ON THE REGIONAL CAMPUSES (contd)**

Dr. Smith: (contd)

Secondly, as we deal with either student services and activities for students on the campuses, or those who might be a part of residential life there, we are going to need to be thinking and developing student activities and services in perhaps a more formal way, or elaborate on them at least. The approach suggested here is that we use a collaboration model. That is, take advantage of Bill Hall and his office and the extent to which we do these things here in Columbus, and do them well. So a collaboration model is being proposed as the regional campuses expand in this area.

Finally, Richard Petty, chair of Psychology, chaired a subcommittee on Faculty/Curriculum, and there were two major issues. As I mentioned earlier, we have been moving toward the one-university model. That is in contrast to the university system model as in the University of Wisconsin at Whitewater, which is a different approach than what we have done here. We've been moving in that direction strongly, and the majority of members of this Commission believe that we do need to do that. For some academic units, though, that raises some longer-term issues for them. So we're suggesting here that the University – we didn't have time in our process – now look in more detail at other institutions that have regional campuses across the country that might provide us with some creative alternatives to some of the issues that we may think we will be facing in this area. By the way, the report will have a lot of detail around what I just said here, in terms of current patterns.

Finally under this topic, right now it's possible to complete some major programs at the regional campuses, and what's being suggested here is that there be some modest expansion of undergraduate major programs. But the twist would be that the individual campuses might have specific needs. This was something like what we did with the business majors, as some of you know. For example, it may be that a need for a certain type of major is more relevant to Lima than it is to Marion. If that is the case, could and should we be thinking about whatever that major might be there and, in fact, that it could be shared by distance, distributed learning in a way that we may not be doing now? So, that's a little twist to this, but I would say – part of my responsibilities include curriculum – that this kind of expansion does need to occur through careful planning; why are we moving in this direction at that location. So we're doing that.

The final point I'll make is that every one of these campuses is co-located with a state technical college. If we're saying that the University has an Academic Plan and it does, and if the regional campuses are a part of the Academic Plan and they are, then if there are issues in terms of co-location and issues of activities back and forth between the two sites, then we need to be monitoring those on a regular basis to see what their effect on planning for the regional campuses would be.

Dr. Moser:

Very good, Randy, thank you. Mr. Chairman, in conclusion, I would like to personally thank the Commission for its excellent work and dedication for this whole process. It's been a long process and they've worked very hard on that. I want to especially say thanks to Randy Smith. Randy has been a real champion in working with the Commission and helping put all this together, and we could not have done it without him. So, I want to especially say that.

My final comment is that in our recommendations, Mr. Chairman, you won't find any grandiose recommendation of closing one campus or opening up three

**STATUS REPORT ON THE PRESIDENTIAL COMMISSION
ON THE REGIONAL CAMPUSES (contd)**

Dr. Moser: (contd)

more, but what you'll find is a collection of issues that have been in among the system for quite some time. We have them all together in one report now and we think the recommendations that we have, once implemented, will help us truly enhance our goal of becoming one University and reaching the Academic Plan aspirations that we've all agreed to in the future.

Thank you very much.

Mr. Patterson:

Thank you, Bobby, Randy, and the Commission. Are there any questions from the members of the Board? Dimon --

Mr. McFerson:

Bob, you indicated that it did take a long time and it did. It's been my experience that when things take a long time, it's because there are a lot of issues to talk about and resolve. Are there any issues that did not get in this report because you just couldn't find resolution or are being deferred for later discussion and comment?

Dr. Moser:

I'd say yes and no on that one, Mr. McFerson. I would say that we think we've uncovered most of the major issues and we have a recommendation on each of those issues. What we don't have is a completeness of how this may unfold once it starts to be implemented. That's when the details will come out.

So we're saying that once we take these recommendations, hopefully accepted by you and by the president and provost, there will be a charge back to someone to implement this. That is when we'll uncover all the details that you're talking about in that particular process. They'll be more issues that will be raised at that time. Our goal is to become one University. We know that's not necessarily going to be perfect in every case, but we want to work toward that and what's keeping us from becoming that. Those are going to be some of the challenges that we think we'll face as we start to implement this plan and get at some of the questions that you're asking right now.

Mr. Patterson:

Any other questions? Thank you very much.

(See Appendix XLVIII for the Presidential Commission on the Regional Campuses, page 1235).

--0--

CGS STUDENT GOVERNMENT REPORT

Mr. Patterson:

I'd like to now call on Briggs Cormier, president of the Council of Graduate Students. I've had the opportunity to meet with the government leaders and they are doing a wonderful job representing their constituencies. We're trying a different approach this year to elevate, if you will, the relationship between the

CGS STUDENT GOVERNMENT REPORT (contd)

Mr. Patterson: (contd)

Board of Trustees and our student leadership, and Briggs is very much a part of that.

Mr. J. Briggs Cormier:

Thank you, Mr. Chairman, Mr. President, members of the Board, and other guests. I brought with me today CGS vice president Eve Scrogam, a master's student in Educational Policy and Leadership, who will be graduating next Friday.

This has been a very outstanding year for CGS, and in recognition of that, we've received the Outstanding Student Organization of the Year Award at the annual leadership ceremony this year. We've had a pretty ambitious agenda. I'm currently working on our annual report – I'm up to about 76 pages right now – and as soon as it is done, I will forward copies to the Board as well as to other administrators on campus.

I'd like to highlight just a few of the things that you will see in this annual report and then I'll ask Eve to talk about some of the things that it is her duty, as vice president, to oversee. Three of the main issues that we took a look at are: 1) diversity; 2) communications; and 3) graduate associate issues, primarily involving compensation and workload expectations on campus.

Going in a random order, CGS is very pleased and excited that the University leadership has included graduate associates in its compensation initiative. We've been part of that process and we're seeing increases in our stipend levels and the level of benefit subsidy for our student health insurance. These are things, thanks to the efforts of many folks here in this room, that the Council is very excited about.

On the issue of communications, we've redesigned our logo and we've done a pretty awesome job this year of utilizing on campus resources. This would be things such as *the Lantern, on Campus*, the *Buckeye Net News*, and *OSU Today*, in terms of trying to communicate what the Council does and how we're doing. We've significantly overhauled our web site, which has just about everything that we've done listed on there, from resolutions to our budget to announcements.

With regard to diversity, we passed this year five different resolutions supporting diversity on several different levels. Also, we've co-sponsored several events throughout the University with academic departments and other service related departments that are diversity specific-related events. The Council was quite pleased to see that the University Senate passed a resolution calling for domestic partners health benefits at OSU.

With that overview, I'd like for Eve to talk a little bit about the three areas that the vice president is responsible for. These would be: 1) recruitment of delegates and committee appointments; 2) new graduate student orientation; and 3) the Graduate Research Forum.

Ms. Eve M. Scrogam:

Good morning, everyone. This past fall I helped organize the Graduate Student Orientation, which was attended by over 1,000 of our new graduate students. We received great feedback that the event was very helpful in acclimating our new students to campus. I'm hoping, based on what we did last fall, that this fall's orientation will be even better. We're organizing a bus tour with COTA, so that

CGS STUDENT GOVERNMENT REPORT (contd)

Ms. Scroggins: (contd)

following orientation we can take the new students and show them around town -- the popular restaurants, shopping malls, the libraries, and the hospitals. So, I'm really looking forward to those improvements.

As far as one of my other tasks as vice president, I've been attempting to fill all of the delegate positions. Currently, we have representation from the 108 graduate programs and this year we met our goal of filling two-thirds of those positions. As far as appointments to University committees, I have a list of over 130 committees that are campus-wide and, I believe, I've gotten a little over 90 percent of those filled. I can't promise that students go to each and every committee meeting, but we do have students appointed and so the graduate voice is being heard across campus.

Finally, the last event that we held was the Graduate Research Forum in April. Currently at the printer is a 300-page document, which is the compilation of all the winners' papers from the Research Forum. It will be the proceedings and I'll be happy to give the Board an edition once it has come out. I would just like to say on a final note that the events that we have do make an impact on the graduate students. I surveyed last year's winners of the Forum and several said that it was the most poignant point of their career at Ohio State. They really felt that they had accomplished something by winning at the Forum, and it's helped them proceed in their professional careers.

Mr. Cormier:

Thank you, Eve. In conclusion, it's been a great opportunity for me to serve the Council of Graduate Students this year. Eve will be leaving, as well as our treasurer Ed Lasseigne, a Ph.D. candidate in French, and our secretary Mike Daniels, a Ph.D. student in linguistics. I will be returning as president next year, and joining me will be Kerry Hodak, a Ph.D. student and law student; her Ph.D. program is political science. Our new secretary will be Christine Masters, a nursing student, and our treasurer will be Jamie Depelteau, a Ph.D. student in integrated biomedical sciences.

With your pleasure, Mr. Chairman, I'd like to invite President Eddie Pauline and Chairman David Lieberman to join me in a presentation for President Kirwan. I must apologize for Todd Armen, who was unable to be here this morning. As you all know, he is a third-year medical student and has a slightly different schedule than the rest of us.

President Kirwan, this has been an outstanding year, and the student leadership would like to extend our appreciation for the hard work you've done on behalf of OSU in general but, in particular, your commitment to students and student needs. You've met with each and every one of us, and on numerous occasions you've come to our meetings and events, and for all of that, we'd like to say thank you with this very small token of our appreciation.

That concludes my report today.

Mr. Patterson:

Thank you, Briggs. Do you want to open that?

CGS STUDENT GOVERNMENT REPORT (contd)

President William E. Kirwan:

Isn't this absolutely exquisite -- a globe with a scene of the campus including Ohio Stadium, and if you wind this key you either hear the *Buckeye Battle Cry* or *Carmen Ohio*. I don't dare do it, because we'd hear it the rest of the day.

I want to thank the students leaders, so much. We are blessed at Ohio State to have such great student leaders, and it has been pure pleasure to work with you because of the constructive things you're doing to advance this University. So thank you very much. I assure you this will sit on my desk in Maryland. Thank you.

--0--

CONSENT AGENDA

President William E. Kirwan:

We have 19 resolutions on the Consent Agenda today and unless there are any objections, I would like to recommend the following resolutions to the Board:

APPOINTMENTS -- UNIVERSITY HOSPITALS BOARD

Resolution No. 2002-135

Synopsis: Approval of the appointments of chairperson and vice chairperson of the University Hospitals Board is proposed.

WHEREAS the Board of Trustees on November 30, 1979, approved the establishment of a University Hospitals Board; and

WHEREAS the membership of the Hospitals Board was approved on April 4, 1980, and has been subsequently amended; and

WHEREAS the chairperson and vice chairperson, chosen from among the citizen members, shall be appointed annually by The Ohio State University Board of Trustees upon recommendation of the president; and

WHEREAS a waiver is requested of that portion of University Hospitals Board bylaw 3335-95-01 which limits appointment to no more than two successive terms:

NOW THEREFORE

BE IT RESOLVED, That the following individuals be appointed to office as so indicated:

Grayce M. Sills, chairperson, University Hospitals Board
Richard M. Murphey, Jr., vice chairperson, University Hospitals Board

CANCER HOSPITAL BOARD REAPPOINTMENT

Resolution No. 2002-136

Synopsis: Reappointment of a member to The Arthur G. James Cancer Hospital and Richard J. Solove Research Institute Board is proposed.

CANCER HOSPITAL BOARD REAPPOINTMENT (contd)

WHEREAS the Board of Trustees on September 1, 1993, approved the establishment of The Arthur G. James Cancer Hospital and Richard J. Solove Research Institute Board; and

WHEREAS it has been stipulated in Board of Trustees Bylaw 3335-1-03 (W) and The James Cancer Hospital and Solove Research Institute Board Bylaw 3335-109-01 that the Cancer Hospital and Research Institute Board shall be comprised of six citizens from the general public who shall be appointed by the University Board of Trustees in consultation with the President; and

WHEREAS the following named person has been nominated and selected for reappointment to the Cancer Hospital and Research Institute Board for the term as specified:

<u>Name</u>	<u>Term of Appointment</u>
Ellen Hardymon	May 14, 2002 to May 13, 2006

NOW THEREFORE

BE IT RESOLVED, That the foregoing nominee be reappointed, effective immediately, as a member of The Arthur G. James Cancer Hospital and Richard J. Solove Research Institute Board for the specific term as set forth above.

AMENDMENTS TO THE *BYLAWS OF THE MEDICAL STAFF OF THE OHIO STATE UNIVERSITY HOSPITALS*

Resolution No. 2002-137

Synopsis: The amendments to the *Bylaws of the Medical Staff* of The Ohio State University Hospitals are recommended for approval.

WHEREAS The Ohio State University Hospitals Board pursuant to bylaw 3335-101-04 of the Hospitals Board Bylaws is authorized to recommend to the Board of Trustees the adoption of amendments to the *Bylaws of the Medical Staff* of The Ohio State University Hospitals; and

WHEREAS the proposed amendments to the *Bylaws of the Medical Staff* of The Ohio State University Hospitals were approved by the University Hospitals Board on April 25, 2002, as attached:

NOW THEREFORE

BE IT RESOLVED, That the foregoing amendments to the *Bylaws of the Medical Staff* of The Ohio State University Hospitals be adopted as recommended and approved April 25, 2002, by the University Hospitals Board.

(See Appendix XLIX for background material, page 1241.)

**AMENDMENTS TO THE BYLAWS OF THE ARTHUR G. JAMES CANCER HOSPITAL
AND RICHARD J. SOLOVE RESEARCH INSTITUTE BOARD AND RULES AND
REGULATIONS OF THE MEDICAL STAFF**

Resolution No. 2002-138

Synopsis: The amendments to the *Bylaws of The Arthur G. James Cancer Hospital and Richard J. Solove Research Institute Board and Rules and Regulations of the Medical Staff of The Arthur G. James Cancer Hospital and Richard J. Solove Research Institute* are recommended for approval.

WHEREAS The Arthur G. James Cancer Hospital and Richard J. Solove Research Institute Board pursuant to bylaw 3335-109-02 of the James Cancer Hospital Board Bylaws is authorized to recommend to the Board of Trustees the adoption of amendments to their *Bylaws* and to the *Rules and Regulations of the Medical Staff of The Arthur G. James Cancer Hospital and Richard J. Solove Research Institute*; and

WHEREAS the proposed amendments to the *James Board Bylaws and Rules and Regulations of the Medical Staff* were previously endorsed and ratified by The Arthur G. James Cancer Hospital and Richard J. Solove Research Institute Board on May 21, 2002, as attached:

NOW THEREFORE

BE IT RESOLVED, That the foregoing amendments to the *James Board Bylaws and Rules and Regulations of the Medical Staff of The Arthur G. James Cancer Hospital and Richard J. Solove Research Institute* be adopted as recommended.

(See Appendix L for background material, page 1259.)

**REGIONAL CAMPUS BOARDS
APPOINTMENTS/REAPPOINTMENTS**

Resolution No. 2002-139

Synopsis: Approval of appointments/reappointments to The Ohio State University Regional Campus Boards is proposed.

WHEREAS the Board of Trustees in 1994 approved the establishment of The Ohio State University Regional Campus Boards; and

WHEREAS it has been previously stipulated that "the board shall be composed of eleven members appointed by The Ohio State University Board of Trustees in consultation with the president of the university" (one member of the board shall be a member of the university board of trustees; nine members shall be private citizens; and one member shall be a student); and

WHEREAS the following named persons have been nominated and selected for appointments/reappointments to the following Regional Campus Boards for the terms as specified:

Mansfield Board Appointments/Reappointments

John S. Roby, 3-year term
David L. Carto, 3-year term (2nd reappointment)
Anne Epperson, 3-year term (3rd reappointment)
Kandice B. Kohler, 1-year term (student appointment)

**REGIONAL CAMPUS BOARDS
APPOINTMENTS/REAPPOINTMENTS (contd)**

Marion Board Appointments/Reappointment

Gary Sims, 3-year term
Steve Winkler, 3-year term
David F. Bacon, 3-year term (3rd reappointment)
Samantha A. Caskey, 1-year term (student appointment)

Newark Board Appointments/Reappointment

Girard E. Besanceney, 3-year term
Marlene M. Eader, 3-year term
Paddy Kutz, 3-year term (2nd reappointment)
Blake C. Zitko, 1-year term (student appointment)

NOW THEREFORE

BE IT RESOLVED, That the foregoing nominees be approved as members of The Ohio State University-Mansfield Board, Marion Board, and Newark Board, effective July 1, 2002.

AMENDMENTS TO THE RULES OF THE UNIVERSITY FACULTY

Resolution No. 2002-140

Synopsis: Approval of the following amendments to the *Rules of the University Faculty* are recommended.

WHEREAS the University Senate pursuant to rule 3335-1-09 of the Administrative Code is authorized to recommend through the President to the Board of Trustees the adoption of amendments to the *Rules of the University Faculty* as approved by the University Senate; and

WHEREAS the proposed changes in the *Rules of the University Faculty* were approved by the University Senate on May 9, 2002:

Amended Rules

3335-7-21 Marks.

The official marks of the university are as follows: "A," "A-," "B+," "B," "B-," "C+," "C," "C-," "D+," "D," "E," "EM," "EN," "I," "K," "P," "PA," "NP," "R," "S," "U," "W." These marks shall have the following meaning:

(A) through (H) unchanged.

(I) "EN" – E, non-attendance

This mark shall be used to indicate that the student was properly registered for the course, but failed to complete the course because of non-attendance. It does not differentiate between the student who never attended or stopped attending at some point during the academic term.

When assigning this mark, an instructor must also provide some indication (e.g. day or week of the academic term) of when the student stopped attending the course.

AMENDMENTS TO THE RULES OF THE UNIVERSITY FACULTY (contd)

Amended Rules (contd)

This mark shall be treated as an "E" for the purpose of calculating a student's point-hour ratio.

~~(J)~~(J) "P" – progress.

Balance unchanged.

~~(J)~~(K) "PA" - pass, "NP" - non-pass.

Balance unchanged.

~~(K)~~(L) "R" - registered to audit.

Balance unchanged.

~~(L)~~(M) "S" - satisfactory, "U" – unsatisfactory.

Balance unchanged.

~~(M)~~(N) "W" – withdrew.

Balance unchanged.

3335-7-25 Credit points.

(A) Credit points shall be assigned on the following basis:

For each credit hour of "A,"	4.0 credit points shall be allowed
For each credit hour of "A-,"	3.7 credit points shall be allowed
For each credit hour of "B+,"	3.3 credit points shall be allowed
For each credit hour of "B,"	3.0 credit points shall be allowed
For each credit hour of "B-,"	2.7 credit points shall be allowed
For each credit hour of "C+,"	2.3 credit points shall be allowed
For each credit hour of "C,"	2.0 credit points shall be allowed
For each credit hour of "C-,"	1.7 credit points shall be allowed
For each credit hour of "D+,"	1.3 credit points shall be allowed
For each credit hour of "D,"	1.0 credit points shall be allowed
For each credit hour of "E,"	0.0 credit points shall be allowed
<u>For each credit hour of "EN."</u>	<u>0.0 credit points shall be allowed</u>

Balance unchanged.

NOW THEREFORE

BE IT RESOLVED, That the foregoing amendments to the *Rules of the University Faculty* be adopted as recommended by the University Senate.

HONORARY DEGREES

Resolution No. 2002-141

Synopsis: The awarding of honorary degrees to George W. Bush, Howard E. LeFevre and Elizabeth "Libby" McKeever Ross, is recommended for approval.

HONORARY DEGREES (contd)

WHEREAS pursuant to paragraph (B)(4) of rule 3335-1-03 of the Administrative Code, the President, after consultation with the Steering Committee of the University Senate, recommended to the Board of Trustees awarding of honorary degrees as listed below:

George W. Bush	Doctor of Public Administration
Howard E. LeFevre	Doctor of Humane Letters
Elizabeth "Libby" McKeever Ross	Doctor of Humane Letters

NOW THEREFORE

BE IT RESOLVED, That the above honorary degrees be awarded in accordance with the recommendation at a time convenient to the University and the recipients.

DEGREES AND CERTIFICATES – SPRING QUARTER COMMENCEMENT

Resolution No. 2002-142

Synopsis: Approval of Degrees and Certificates for Spring Quarter is proposed.

WHEREAS pursuant to paragraph (E) of rule 3335-1-06 of the Administrative Code, the Board has authority for the issuance of degrees and certificates; and

WHEREAS the faculties of the colleges and schools shall transmit, in accordance with rule 3335-9-29 of the Administrative Code, for approval by the Board of Trustees the names of persons who have completed degree and certificate requirements:

NOW THEREFORE

BE IT RESOLVED, That the degrees and certificates be conferred on June 14, 2002, to those persons who have completed the requirements for their respective degrees and certificates and are recommended by the colleges and schools, and that the names of those persons awarded degrees and certificates be included in the minutes of this meeting.

PERSONNEL ACTIONS

Resolution No. 2002-143

BE IT RESOLVED, That Resolution 77-92 and the provisions of the February 6, 1959 Report of the Committee on Retirement and Insurance, calling for "Principal Administrative Officials" to be relieved of their administrative assignments at age 65, be waived to allow for the extension of administrative appointment of Randall B. Ripley as Dean of the College of Social and Behavioral Sciences beyond his sixty-fifth birthday; and

BE IT RESOLVED, That the personnel actions as recorded in the Personnel Budget Records of the University since the May 3, 2002 meeting of the Board, including the following Appointments/Reappointments, Promotion, Extension of Term -- Principal Administrative Official, Appointments/Reappointments of Chairpersons, Leaves of Absence Without Salary, Professional Improvement Leaves, and Emeritus Titles, as detailed in the University Budget be approved; and

BE IT FURTHER RESOLVED That the Medical Staff Appointments (The Arthur G. James Cancer Hospital and Richard J. Solove Research Institute) approved May 21, 2002, by The Arthur G. James Cancer Hospital and Richard J. Solove Research Institute Board, be ratified.

PERSONNEL ACTIONS (contd)

Appointments

Name: GARY BOS
Title: Professor (The Frank J. Kloenne Chair in Orthopedic Surgery)
Department: Orthopaedics
Term: September 1, 2002, through June 30, 2006
Present Position: Professor of Orthopaedic Surgery, University of North Carolina, Chapel Hill, NC

Name: JOAN M. HERBERS
Title: Dean
College: Biological Sciences
Term: September 1, 2002, through June 30, 2007
Present Position: Chair and Professor, Department of Biology, Colorado State University, Fort Collins, Colorado

Name: WILLIAM L. MACDONALD
Title: Interim Academic Dean – Newark Campus
Term: July 1, 2002, through June 30, 2003
Present Positions: Assistant Academic Dean, and Associate Professor, Department of Sociology (Newark Campus)

Name: GIORGIO RIZZONI
Title: Professor (The Ford Motor Company Chair in Electromechanical Systems)
College: Engineering
Term: July 1, 2002, through June 30, 2007
Present Position: Professor, Department of Mechanical Engineering

Name: LINDA J. SAIF
Title: Distinguished University Professor
Department/Program: Veterinary Preventive Medicine/Food Animal Health Research Program
Effective: June 7, 2002

Name: DANIEL D. SEDMAK
Title: Executive Vice Dean
College: College of Medicine and Public Health
Effective: July 1, 2002
Concurrent Appt: Associate Vice President for Health Sciences Education and Vice Dean for Education

Name: LONNIE G. THOMPSON
Title: Distinguished University Professor
Department/Center: Geological Sciences/Byrd Polar Research Center
Effective: June 7, 2002

Promotion

Name: KAMILLA K. SIGAFOOS
Title: Associate Vice President for Health Services
Office: Health Services
Effective: June 1, 2002
Present Position: Chief Operating Officer, University Hospitals

PERSONNEL ACTIONS (contd)

Reappointments

Name: FREDERICK H. DAVIDORF
Title: Professor (The Martha G. and Milton Staub Chair for Research in Ophthalmology)
College: Medicine and Public Health
Term: July 1, 2002, through June 30, 2006

Name: PETER E. GEIER
Title: Senior Associate Vice President for Business Development and Strategic Planning, and Chief Financial Officer/Chief Operating Officer
Office/Center: Health Sciences/Medical Center
Effective: July 1, 2002

Name: J. LAYNE MOORE
Title: Professor (Richard J. and Martha D. Denman Professorship for Clinical Research in Epilepsy)
College: Medicine and Public Health
Term: July 1, 2002, through June 30, 2006

Extension of Term -- Principal Administrative Official

RANDALL B. RIPLEY, Dean, College of Social and Behavioral Sciences, effective July 1, 2003, through June 30, 2004, pursuant to rule 3335-1-03 (R) of the Administrative Code.

Appointment of Chairpersons

July 1, 2002, through June 30, 2003

Art	Ardine K. Nelson*
Dance	Michael K. Bruce*

July 1, 2002, through June 30, 2006

Industrial, Interior & Visual Communication	Wayne E. Carlson
---	------------------

September 1, 2002, through June 30, 2006

Orthopaedics	Gary Bos
--------------	----------

Reappointment of Chairpersons

July 1, 2002, through December 31, 2002

Emergency Medicine	Douglas A. Rund
Molecular Virology, Immunology and Medical Genetics	Caroline C. Whitacre
Physical Medicine and Rehabilitation	William S. Pease

July 1, 2002, through June 30, 2003

Neuroscience	Michael S. Beattie*
Ophthalmology	Paul A. Weber
Psychiatry	Radu V. Saveanu*

*Interim

PERSONNEL ACTIONS (contd)

Reappointment of Chairpersons (contd)

July 1, 2002, through June 30, 2006

Entomology	David L. Denlinger
Evolution, Ecology and Organismal Biology	Ralph E. J. Boerner
Food Science and Technology	Kenneth Lee
Molecular Genetics	Lee F. Johnson
Plant Biology	Richard T. Sayre

October 1, 2002, through September 30, 2006

Marketing and Logistics	Robert E. Burnkrant
-------------------------	---------------------

Leaves of Absence Without Salary

SHELDON W. HALPERN, Professor, Moritz College of Law, effective Autumn Semester 2002 and Spring Semester 2003, to serve as a Visiting Professor of Law at Santa Clara University.

ARKADY A. TSEYTLIN, Professor, Department of Physics, effective Autumn Quarter 2002 and Winter Quarter 2003, to do research in string theory at Imperial College, London, England.

THOMAS P. GALLANIS, Jr., Associate Professor, Moritz College of Law, effective Autumn Semester 2002, to serve as a Visiting Professor of Law at Washington & Lee University.

Professional Improvement Leaves

RALPH E. J. BOERNER, Chairperson and Professor, Department of Evolution, Ecology, and Organismal Biology, effective Winter Quarter and Spring Quarter 2003.

HANI J. DOSS, Professor, Department of Statistics, effective Autumn Quarter 2002.

EARL F. EPSTEIN, Professor, School of Natural Resources, effective Winter Quarter and Spring Quarter 2003.

PREM K. GOEL, Professor, Department of Statistics, effective Autumn Quarter 2002 and Winter Quarter 2003.

TIMOTHY E. HERON, Professor, School of Physical Activity and Educational Services, effective Spring Quarter 2003.

ANTHONY MUGHAN, Professor, Department of Political Science, effective Winter Quarter 2003.

NEIL E. SMECK, Professor, School of Natural Resources, effective Winter Quarter and Spring Quarter 2003.

RICHARD H. STECKEL, Professor, Department of Economics, effective Autumn Quarter 2002, Winter Quarter and Spring Quarter 2003.

PATRICIA L. STUHR, Professor, Department of Art Education, effective Autumn Quarter 2002, Winter Quarter and Spring Quarter 2003.

CARL R. ZULAUF, Professor (The Francis B. McCormick Professorship in Agricultural Marketing and Policy), Department of Agricultural, Environmental, and Development Economics, effective Autumn Quarter 2002, Winter Quarter, Spring Quarter, and Summer Quarter 2003.

JEROME B. ZUTELL, JR., Professor, School of Teaching and Learning, effective Winter Quarter and Spring Quarter 2003.

PERSONNEL ACTIONS (contd)

Professional Improvement Leaves (contd)

CYNTHIA B. DILLARD, Associate Professor, School of Teaching and Learning, effective Autumn Quarter 2002 and Spring Quarter 2003.

THOMAS E. NELSON, Associate Professor, Department of Political Science, effective Autumn Quarter 2002, Winter Quarter and Spring Quarter 2003.

R. MARK SULC, Associate Professor, Department of Horticulture and Crop Science, effective Summer Quarter and Autumn Quarter 2002, and Winter Quarter and Spring Quarter 2003.

Emeritus Titles

RONALD L. ST. PIERRE, College of Medicine and Public Health, with the title Associate Vice President and Professor Emeritus, effective July 1, 2002.

RUTH A. ALTSCHULD, Department of Molecular and Cellular Biochemistry, with the title Professor Emeritus, effective July 1, 2002.

BOGDAN M. BAISHANSKI, Department of Mathematics, with the title Professor Emeritus, effective June 1, 2002.

RUDINE S. BISHOP, School of Teaching and Learning, with the title Professor Emeritus, effective July 1, 2002.

LEE B. BROWN, Department of Philosophy, with the title Professor Emeritus, effective July 1, 2002.

KEITH A. HALL, School of Educational Policy and Leadership, with the title Professor Emeritus, effective June 1, 2002.

SEYMOUR KLEINMAN, School of Educational Policy and Leadership, with the title Professor Emeritus, effective July 1, 2002.

CHARLES F. MUELLER, Department of Radiology, with the title Professor Emeritus, effective June 1, 2002.

MARVIN L. OLMSTEAD, Department of Veterinary Clinical Sciences, with the title Professor Emeritus, effective June 1, 2002.

G. MICHEAL RILEY, Department of History, with the title Professor Emeritus, effective July 1, 2002.

STEPHEN V. TRACY, Department of Greek and Latin, with the title Professor Emeritus, effective July 1, 2002.

ROBERT F. WING, Department of Astronomy, with the title Professor Emeritus, effective July 1, 2002.

PAUL E. YOUNG, JR., Austin E. Knowlton School of Architecture, with the title Professor Emeritus, effective July 1, 2002.

GAIL MCCUTCHEON, School of Educational Policy and Leadership, with the title Associate Professor Emeritus, effective September 1, 2002.

PETER W. SPIKE, Department of Animal Sciences, with the title Associate Professor Emeritus, effective June 1, 2002.

PERSONNEL ACTIONS (contd)

Emeritus Titles (contd)

STIG M. BERGSTROM, Department of Geological Sciences, with the title Professor Emeritus, change date from July 1, 2002, to January 1, 2003.

Medical Staff Appointments (The Arthur G. James Cancer Hospital and Richard J. Solove Research Institute)

April 2002

Initial Appointments – Faculty

Matthew L. Schlossberg, M.D., Anesthesiology (eff. 5/1/02), Clinical Assistant Professor, Associate Attending

Initial Appointments – Community

Richard E. Gordon, Jr., M.D., Family Medicine, Community Associate

Change in Department

Magali Fernandez, M.D., Associate Attending, from Neurology to Internal Medicine

Additional Privileges Requested

Gregory Ness, D.D.S., Dentistry, moderate and deep conscious sedation

May 2002

Initial Appointments – Faculty

Robert R. Crowell, M.D., Orthopaedics, Clinical Assistant Professor, Clinical Attending

Initial Appointments – Advanced Practice Nursing

Mollie E. Moran, R.N., C.N.P., Allied Health Professional, Division of Hematology/Oncology

Provisional to Full Appointments

Sue Bell, R.N., C.N.P., Surgery, Allied Health Professional
Christopher Caputo, D.O., Internal Medicine, Cardiology, Associate Attending
Scott Holiday, M.D., Internal Medicine, General Medicine, Associate Attending
Lisa Rader, R.N., C.N.P., Hematology/Oncology, Allied Health Professional

Reappointment – Faculty, 7/1/2002 – 6/30/2004

William S. Pease, M.D., Physical Medicine and Rehabilitation, Associate Attending
Edward Martin, Jr., M.D., Surgical Oncology, Attending

Reappointment – Advanced Practice Nurses, 7/1/2002 – 6/30/2002

Jon Mickle, R.N., C.N.P.
Molly Moran, R.N., C.N.S.
Lisa Rader, R.N., C.N.P.
Patrice Rancour, R.N., C.N.S.

PERSONNEL ACTIONS (contd)

Medical Staff Appointments (The Arthur G. James Cancer Hospital and Richard J. Solove Research Institute) (contd)

May 2002 (contd)

Reappointment – Community Associates, 7/1/2002 – 6/30/2004

Akber Mohammed, M.D., Cardiology
Richard Marsh, M.D., Pathology
Peter Muir, M.D., Family Medicine
Marvin Narcelles, M.D., General Medicine
Mujeeb Ranginwala, M.D., Rheumatology
John Sutter, M.D., Family Medicine

RESOLUTION IN MEMORIAM

Resolution No. 2002-144

Synopsis: Approval of a Resolution in Memoriam is proposed.

RESOLVED, That the Board adopt the following Resolution in Memoriam and that the President be requested to convey a copy to the family of the deceased.

Irma M. Cooper

The Board of Trustees of The Ohio State University expresses its sorrow upon the death on April 29, 2002, of Irma M. Cooper, professor emeritus in the School of Music.

Irma Cooper joined the faculty of the School of Music at The Ohio State University in 1964 and continued as professor of voice until she retired in 1983. Professor Cooper taught voice and diction classes, directed the opera, and performed as soprano soloist on numerous occasions. Her talents, her energy, her passion for singing, and her personal grace and integrity showed through everything she did.

Professor Cooper started her musical career in Iowa, eventually graduating with a master's degree in voice from the American Conservatory of Music. Her post-graduate study included Julliard, the Vienna Academy, and the Aspen School. She went on to pursue her career in Germany where she remained for the next ten years and performed over 600 performances of more than 30 leading dramatic soprano roles in various German opera houses.

In 1969 she became a member of the first voice faculty at the new summer program of the American Institute of Musical Studies (AIMS) in Graz, Austria, where later she coordinated a growing number of faculty participants. This organization, of which she eventually became chairperson of the Board of Directors, provides a training ground for advanced singers to refine their artistic skills for professional careers in opera performance and in teaching. Professor Cooper was active with AIMS until the summer of 2001, her 88th year.

Her influence on countless students both nationally and internationally has been, and will continue to be, remarkable in its intensity on so many different levels. Although Professor Cooper retired from OSU, she never retired from her involvement in everything related to singing and singers. She was a co-founder, past vice-president, and life member of Opera Columbus; founder of their national competition for aspiring professional artists; and a founding member of the National Association of Teaching of Singing Foundation.

Professor Cooper was very committed to The Ohio State University and, through the years, she offered gifts of financial support to the School of Music in order to provide more opportunities for the students. At the Voice Gala held in her honor in Autumn Quarter 2000, Professor Cooper

RESOLUTION IN MEMORIAM (contd)

Irma M. Cooper (contd)

came on stage and presented a huge gift to the School of Music, which now underwrites an endowed fund to provide international opportunities for music students.

On behalf of the University community, the Board of Trustees expresses to the family of Professor Irma M. Cooper its deepest sympathy and sense of understanding of their loss. It was directed that this resolution be inscribed upon the minutes of the Board of Trustees and that a copy be tendered to her family as an expression of the Board's heartfelt sympathy.

REPORT OF RESEARCH CONTRACTS AND GRANTS

Resolution No. 2002-145

Synopsis: The reports on research and other sponsored program contracts and grants and the summary for April 2002 are presented for Board acceptance.

WHEREAS monies are solicited and received on behalf of the University from governmental, industrial, and other agencies in support of research, instructional activities, and service; and

WHEREAS such monies are received through The Ohio State University Research Foundation:

NOW THEREFORE

BE IT RESOLVED, That the research agreement between The Ohio State University and The Ohio State University Research Foundation for the contracts and grants reported herein during the month of April 2002 be approved.

REPORT ON UNIVERSITY DEVELOPMENT

Resolution No. 2002-146

Synopsis: The report on the receipt of gifts and the summary for April 2002 are presented for Board acceptance.

WHEREAS monies are solicited and received on behalf of the University from alumni, industry, and various individuals in support of research, instructional activities, and service; and

WHEREAS such gifts are received through The Ohio State University Development Fund and The Ohio State University Foundation; and

WHEREAS this report includes the establishment of The Carl M. and Grace Baldwin Chair in Ophthalmology; and

WHEREAS this report includes the establishment of twenty-two (22) new named endowed funds and the amendment of two (2) named endowed fund:

NOW THEREFORE

BE IT RESOLVED, That the acceptance of the report from The Ohio State University Development Fund and The Ohio State University Foundation during the month of April 2002 be approved.

REPORT ON UNIVERSITY DEVELOPMENT (contd)

TOTAL UNIVERSITY PRIVATE SUPPORT

July through April
2000-2001 Compared to 2001-2002

GIFT RECEIPTS BY DONOR TYPE

	Dollars July through April		
	<u>2000-2001</u>	<u>2001-2002</u>	<u>%Change</u>
Individuals:			
Alumni (Current Giving)	\$25,855,411	\$28,073,111	9
Alumni (From Bequests)	<u>5,902,557</u>	<u>4,938,850</u>	(16)
Alumni Total	\$31,757,968	\$33,011,961	4
Non-Alumni (Current Giving)	\$22,113,190	\$13,511,369	(39)
Non-Alumni (From Bequests)	<u>9,956,467</u>	<u>3,421,533</u>	(66)
Non-Alumni Total	\$32,069,657	\$16,932,902	(47)
Individual Total	\$63,827,625	\$49,944,863	(22) ^A
Corporations/Corp/Foundations	\$34,454,728	\$36,238,757	5
Private Foundations	\$12,125,835	\$16,133,127	33 ^B
Associations and Other Organizations	<u>\$3,827,514</u>	<u>\$3,886,045</u>	2
Total	\$114,235,702	\$106,202,792	(7)

NOTES

- A Overall individual giving is down 22% in that gifts at the \$10,000 or more level are down 31% (\$47.4 million from 509 gifts last year compared with \$32.9 million from 431 gifts this year.)
- B Foundation giving at the \$10,000 or more level is up for the first ten months of the fiscal year (\$11.3 million from 160 gifts last year; \$15.3 million from 179 gifts this year).

REPORT ON UNIVERSITY DEVELOPMENT (contd)

TOTAL UNIVERSITY PRIVATE SUPPORT (contd)

July from April
2000-2001 Compared to 2001-2002

GIFT RECEIPTS BY PURPOSE

	Dollars July through April		
	<u>2000-2001</u>	<u>2001-2002</u>	<u>% Change</u>
Gift Receipts to Current Use and Endowment Funds:			
Buildings/Equipment	\$21,478,894	\$18,294,747	(15)
Faculty Support	\$9,973,448	\$10,813,117	8
Program Support	\$62,428,430	\$57,415,295	(8)
Student Financial Aid	\$10,878,324	\$11,333,313	4
Annual Funds-Colleges/Departments	\$7,802,666	\$7,234,856	(7)
Annual Funds-University	<u>\$1,673,940</u>	<u>\$1,111,464</u>	(34)
Total	\$114,235,702	\$106,202,792	(7)

GIFT ADDITIONS TO ENDOWMENT

Dollars
July through April

<u>2000-2001</u>	<u>2001-2002</u>	<u>% Change</u>
\$29,626,807	\$34,202,311	15

REPORT ON UNIVERSITY DEVELOPMENT (contd)

THE OHIO STATE UNIVERSITY DEVELOPMENT FUND

	<u>Previous Gifts</u>	<u>Current Gifts</u>	<u>Total Gifts</u>
<u>Establishment of Named Endowed Chair</u>			
The Carl M. and Grace C. Baldwin Chair in Ophthalmology (Used to provide a chair position in the College of Medicine and Public Health; provided by gifts from the estate of Carl M. Baldwin and Grace C. Baldwin)		\$2,000,000.00	\$2,000,000.00
<u>Establishment of Named Endowed Funds</u>			
The Fowler Physics Research Endowment Fund (Used to provide research support for a distinguished senior faculty member in the Department of Physics; provided by the Department of Physics and the College of Mathematical and Physical Sciences)		\$70,000.00	\$70,000.00
The Lewis I. Day Advancement Fund (Used to advance the activities of the Fisher College of Business; provided by gifts from Lewis I. Day)		\$58,846.10	\$58,846.10
The Dr. Carleton W. Schwiesow Endowed Scholarship Fund (Used to support a student in the College of Veterinary Medicine; provided by gifts from the estate of Dr. Carleton W. Schwiesow)		\$47,084.55	\$47,084.55
The Irene Bandy-Hedden Scholarship Fund (Used to support students in the College of Education; provided by gifts from Dr. Irene Bandy-Hedden)		\$15,805.00	\$15,805.00

THE OHIO STATE UNIVERSITY FOUNDATION

	<u>Previous Gifts</u>	<u>Current Gifts</u>	<u>Total Gifts</u>
<u>Establishment of Named Endowed Funds</u>			
The William H. and Laceryjette V. Casto Professorship in Interprofessional Education Fund (Used to support the work of a distinguished professor in interprofessional education in the College of Education; provided by gifts from William H. and Laceryjette V. Casto)		\$304,530.00	\$304,530.00

REPORT ON UNIVERSITY DEVELOPMENT (contd)

THE OHIO STATE UNIVERSITY FOUNDATION (contd)

	<u>Previous Gifts</u>	<u>Current Gifts</u>	<u>Total Gifts</u>
<u>Establishment of Named Endowed Funds (contd)</u>			
The E. W. Hatton Fund for Pediatric Pharmacy Research (Used to improve effectiveness, safety, and uses of medicines in pediatric and geriatric patients; provided by gifts from Isabel Hatton Simmons)		\$250,000.00	\$250,000.00
The Dr. Herbert L. Fenburr Fund for Human Cancer Genetics Research (Used to support an endowed fund in human cancer genetics research; provided by gifts from Dorothy J. Fenburr and Margaret F. Davenport)	\$232,477.48		\$232,477.48
The Evelyn Moreida Krislov Scholarship Fund (Used to provide scholarships for second-year graduate students in the College of Social Work who have an interest in the field of aging; provided by a gift from Joseph Krislov)		\$103,049.12	\$103,049.12
The Kenneth B. Cummins Endowment Fund (Used to aid worthy undergraduate students in the College of Mathematics and Physical Sciences, or at the discretion of the department chairperson to enhance undergraduate instruction in the Department of Mathematics; provided by gifts from Dr. Kenneth B. Cummins)	\$63,596.65		\$63,596.65
The Family and Consumer Sciences Education Program Fund (Used to support programs in family and consumer sciences education for the purpose of teacher preparation and licensure to teach in Ohio schools grades 7-12; provided by gifts from Penelope A. Reighart)		\$51,272.20	\$51,272.20
The Raymond W. Doskotch Graduate Fellowship Fund in Medicinal Chemistry and Pharmacognosy (Used to provide one graduate student fellowship to a student whose research emphasizes natural product chemistry within the Division of Medicinal Chemistry and Pharmacognosy; provided by gifts from Dr. Jinn and Dr. Ze-Ai Chang Wu)	\$45,000.00		\$45,000.00
The Edward F. Hayes Graduate Research Award Fund (Used to provide graduate research awards in conjunction with The Edward F. Hayes Graduate Research Forum; provided by gifts from friends and family members)		\$29,794.96	\$29,794.96

REPORT ON UNIVERSITY DEVELOPMENT (contd)

THE OHIO STATE UNIVERSITY FOUNDATION (contd)

	<u>Previous Gifts</u>	<u>Current Gifts</u>	<u>Total Gifts</u>
<u>Establishment of Named Endowed Funds (contd)</u>			
The Mollmann Family Cancer Research Endowment Fund (Used to support cancer research; provided by a gift from Mr. and Mrs. Joe Mollmann)		\$29,300.00	\$29,300.00
Belmont County Alumni Scholarship Endowed Fund (Used to provide academic merit scholarships for entering freshman from high schools in Belmont County; provided by gifts from members and friends of the Belmont County Alumni Club)		\$27,168.13	\$27,168.13
The Robert Godfrey Arend Family Football Scholarship Fund (Used to supplement the student-athlete grant-in-aid scholarship costs of a student athlete from Northeastern Ohio who is a member of a varsity football team; provided by gifts from Robert Godfrey Arend, Todd and Maria Arend, and Katherine Elizabeth Arend and Alexandria Grace Arend)		\$26,489.36	\$26,489.36
The Charles and Betty Dougherty Scholarship Fund (Used to award scholarships to students enrolled in the fluid power or power and equipment program at The Ohio State University ATI; provided by a gift from Charles and Betty Dougherty)		\$25,590.75	\$25,590.75
The Bruce W. Erickson Distinguished Scholar Fund (Used to provide a scholarship for a distinguished scholar enrolled in the College of Mathematical and Physical Sciences; provided by gifts from the Nanette N. and Robert M. Hoge Fund at the Columbus Foundation)		\$25,000.00	\$25,000.00
The Kelm Family Engineering Scholarship Fund (Used to provide one or more merit scholarships to students majoring in engineering; provided by a gift from Sharon Simon Kelm and James S. Kelm)		\$25,000.00	\$25,000.00
The William and Phyllis Kraner Athletic Scholarship Fund (Used to provide scholarship cost of a student athlete who is a member of a varsity sports team; provided by gifts from the Kraner family)		\$25,000.00	\$25,000.00
The Sheffer Corporation Dean's Innovation Fund (Used to promote initiatives by the faculty and staff designed to increase the quality of teaching, research, and involvement with the business community; provided by gifts from Jeffrey R. Norris and the Sheffer Corporation)		\$25,000.00	\$25,000.00

REPORT ON UNIVERSITY DEVELOPMENT (contd)

THE OHIO STATE UNIVERSITY FOUNDATION (contd)

	<u>Previous Gifts</u>	<u>Current Gifts</u>	<u>Total Gifts</u>
<u>Establishment of Named Endowed Funds (contd)</u>			
Frederick A. Smith Memorial Scholarship Fund (Used to support scholarships for one or more deserving welding engineering students; provided by gifts from Denise Smith, Mr. and Mrs. Joseph R. Smith, and family and friends)		\$25,000.00	\$25,000.00
The Donald E. Yingst Agricultural Vice President's Fund (Used to support programs identified as current and critical priorities in the College of Food, Agricultural, and Environmental Sciences; provided by gifts from Donald E. Yingst)		\$25,000.00	\$25,000.00
<u>Change in Description of Named Endowed Fund</u>			
The Griffith Family Scholarship Endowment Fund			
<u>Change in Name and Description of Named Endowed Fund</u>			
From: The Harold Brenner Pepinsky Research and Lectureship Fund			
To: The Harold Brenner Pepinsky Early Career Award Fund in Neurobehavioral Science			
Total	\$341,074.13	\$3,188,930.17	\$3,530,004.30

THE OHIO STATE UNIVERSITY DEVELOPMENT FUND

Establishment of Named Endowed Chair

The Carl M. and Grace C. Baldwin Chair in Ophthalmology

The Carl M. and Grace C. Baldwin Chair in Ophthalmology was established on June 7, 2002, in accordance with the guidelines approved by the Board of Trustees of The Ohio State University, with gifts from the estate of Carl M. Baldwin (attended 1905 and 1907) and Grace C. Baldwin of Columbus, Ohio.

All gifts are to be invested in the University's Permanent Endowment Fund, under the rules and regulations adopted by the Board of Trustees of The Ohio State University, with the right to invest and reinvest as occasion dictates.

The annual income shall provide for salary support of a chair position in the College of Medicine and Public Health for the purpose of the study of the eye, causes of blindness, the restoration of sight to the blind, and the treatment of persons threatened with loss of sight. The position shall be held by a nationally eminent physician faculty member as recommended by the chairperson of the Department of Ophthalmology in consultation with the senior vice president for Health Sciences and dean of the College of Medicine and Public Health. The activities of the endowed chair holder shall be reviewed no less than every five years by the senior vice president and dean to determine compliance with the intent of the donor as well as the academic and research standards of the University.

REPORT ON UNIVERSITY DEVELOPMENT (contd)

THE OHIO STATE UNIVERSITY DEVELOPMENT FUND (contd)

Establishment of Named Endowed Chair (contd)

The Carl M. and Grace C. Baldwin Chair in Ophthalmology (contd)

It is the desire of the donors that this fund should benefit the University in perpetuity. If the need for this fund should cease to exist or so diminish as to provide unused income, then another use shall be designated by the Board of Trustees in consultation with the senior vice president for Health Sciences and dean of the College of Medicine and Public Health in order to carry out the desire of the donors.

\$2,000,000.00

Establishment of Named Endowed Funds

The Fowler Physics Research Endowment Fund

The Fowler Physics Research Endowment Fund was established on June 7, 2002, by the Board of Trustees of The Ohio State University with unrestricted development funds from the Department of Physics and the College of Mathematical and Physical Sciences.

All gifts are to be invested in the University's Permanent Endowment Fund, under the rules and regulations adopted by the Board of Trustees of The Ohio State University, with the right to invest and reinvest as occasion dictates.

The annual income shall be used to provide research support for a distinguished senior faculty member in the Department of Physics. The chairperson of the Department of Physics, with the approval of the dean of the College of Mathematical and Physical Sciences, shall designate this faculty member.

In any given year that the endowment income is not fully expended, the unused portion may be reinvested in the endowment principal at the discretion of the appropriate college dean or department chairperson.

It is the desire of the donor that this fund should benefit the University in perpetuity. If the need for this fund should cease to exist or so diminish as to provide unused income, then another use shall be designated by the Board of Trustees in consultation with the appropriate college dean or department chairperson in order to carry out the desire of the donor.

\$70,000.00

The Lewis I. Day Advancement Fund

The Lewis I. Day Advancement Fund was established on June 7, 2002, by the Board of Trustees of The Ohio State University with gifts from Lewis I. Day (B.S.Bus.Adm. 1935) of Upper Arlington, Ohio.

All gifts are to be invested in the University's Permanent Endowment Fund, under the rules and regulations adopted by the Board of Trustees of The Ohio State University, with the right to invest and reinvest as occasion dictates.

The annual income shall be used to advance the Fisher College of Business' activities, including but not restricted to: student scholarships, faculty support, and other program funding as defined by the dean of The Max M. Fisher College of Business. Scholarships will be awarded in consultation with the University Committee on Student Financial Aid.

REPORT ON UNIVERSITY DEVELOPMENT (contd)

THE OHIO STATE UNIVERSITY DEVELOPMENT FUND (contd)

Establishment of Named Endowed Funds (contd)

The Lewis I. Day Advancement Fund (contd)

It is the desire of the donor that this fund should benefit the University in perpetuity. If the need for this fund should cease to exist or so diminish as to provide unused income, then another use shall be designated by the Board of Trustees in consultation with the dean of the Fisher College of Business, department chairperson, or program administrative officer in order to carry out the desire of the donor.

\$58,846.10

The Dr. Carleton W. Schwiesow Endowed Scholarship Fund

The Dr. Carleton W. Schwiesow Endowed Scholarship Fund was established on June 7, 2002, by the Board of Trustees of The Ohio State University with gifts from the estate of Dr. Carleton W. Schwiesow (D.V.M. 1936).

All gifts are to be invested in the University's Permanent Endowment Fund, under the rules and regulations adopted by the Board of Trustees of The Ohio State University, with the right to invest and reinvest as occasion dictates.

The annual income shall be used to support one (1) veterinary student per year who is "worthy and needy." Recipients will be selected by the dean of the College of Veterinary Medicine in consultation with the associate dean for Student Affairs. The scholarship will be awarded in consultation with the University Committee on Student Financial Aid.

Throughout his lifetime Dr. Schwiesow was grateful for the fine education he received from the University. He was hopeful that his gift would enable other students to enjoy a full and professionally rewarding career in the practice of veterinary medicine.

It is the desire of the donor that this fund should benefit the University in perpetuity. If the need for this fund should cease to exist or so diminish as to provide unused income, then another use shall be designated by the Board of Trustees in consultation with the dean of the College of Veterinary Medicine in order to carry out the desire of the donor.

\$47,084.55

The Irene Bandy-Hedden Scholarship Fund

The Irene Bandy-Hedden Scholarship Fund was established on June 7, 2002, by the Board of Trustees of The Ohio State University, with gifts from Dr. Irene Bandy-Hedden (Ph.D. 1979).

This endowment is a manifestation of Dr. Bandy-Hedden's long-time commitment to education in the State of Ohio and to The Ohio State University College of Education.

Dr. Bandy-Hedden's career included teacher, counselor, and administrator in urban, rural, and Appalachian areas across Ohio and in other states. She spent a number of years at the state level in Ohio in several positions, ending her formal career as the assistant superintendent of public instruction. Her understanding of student needs and her work with school staffs and parents stimulated her commitment to the need for diversity among education personnel. As a consultant, Dr. Bandy-Hedden continues to promote environments that invite students to actively participate in the teaching-learning activities presented to them.

REPORT ON UNIVERSITY DEVELOPMENT (contd)

THE OHIO STATE UNIVERSITY DEVELOPMENT FUND (contd)

Establishment of Named Endowed Funds (contd)

The Irene Bandy-Hedden Scholarship Fund (contd)

All gifts are to be invested in the University's Permanent Endowment Fund, under the rules and regulations adopted by the Board of Trustees of The Ohio State University, with the right to invest and reinvest as occasion dictates.

The annual income shall be used to provide financial support to students in the College of Education who are preparing to be teachers, administrators, or counselors and who plan to pursue their careers in Ohio. With all other qualities being equal and unless prohibited by specific federal or state law, considerations will be given as follows: first preference shall be given to African-American students, second preference shall be given to women students, and third preference shall be given to students with disabilities. Selection of the recipients shall be made by the dean of the College of Education in consultation with the Office of Student Services and the University Committee on Student Financial Aid.

It is the desire of the donor that this fund should benefit the University in perpetuity. If the need for this fund should cease to exist or so diminish as to provide unused income, then another use shall be designated by the Board of Trustees in consultation with the appropriate college dean, department chairperson, or program administrative officer in order to carry out the desire of the donors.

\$15,805.00
(Grandfathered)

THE OHIO STATE UNIVERSITY FOUNDATION

Establishment of Named Endowed Funds

The William H. and Laceryjette V. Casto Professorship
in Interprofessional Education Fund

The William H. and Laceryjette V. Casto Professorship in Interprofessional Education Fund was established on June 7, 2002, in accordance with the guidelines approved by the Board of Directors of The Ohio State University Foundation, with gifts from William H. and Laceryjette V. Casto and their families.

All gifts are to be invested by the Foundation, under the rules and regulations adopted by the Foundation's Board of Directors, with the right to invest and reinvest as occasion dictates.

Until such time as the professorship is fully funded at \$500,000, income up to \$12,000 per year shall be distributed to the Interprofessional Commission of Ohio to support interprofessional education. Any income above \$12,000 per year shall be reinvested in the endowment principal.

If the Interprofessional Commission of Ohio should no longer be in existence, all income would revert to the principal of the fund until such time as the professorship is fully funded.

When the professorship is fully funded, all income from the fund shall be used to support the work of a distinguished professor in interprofessional education in the College of Education, in partnership with the Interprofessional Commission of Ohio.

REPORT ON UNIVERSITY DEVELOPMENT (contd)

THE OHIO STATE UNIVERSITY FOUNDATION (contd)

Establishment of Named Endowed Funds (contd)

The William H. and Laceryjette V. Casto Professorship
in Interprofessional Education Fund (contd)

While housed in the College of Education, the Casto Professor will also hold concurrent joint appointments in departments in at least one professional college other than the College of Education. Appointment to the Casto Professorship will be made by the dean of the College of Education in consultation with the board of trustees of the Interprofessional Commission of Ohio.

The faculty member appointed as the William H. and Laceryjette V. Casto Professor of Interprofessional Education will have the following minimum qualifications: experience in the professional practice of one or more human service disciplines; advanced academic and/or professional training in a human service discipline other than education; ability to advance current knowledge about interprofessional education and practice; willingness to develop a record of scholarship and experience in teaching, research, publication, and external funding in the field of interprofessional education and practice; and potential to become a leader in the field of interprofessional education and practice.

It is the desire of the donors that this fund should benefit the University in perpetuity. Should the need for this fund cease to exist or so diminish as to provide unused income, then the income may be used to advance interprofessional education at The Ohio State University in a way determined by the Board of Trustees to be in keeping with the wishes of the donors, with recommendations from the dean of the College of Education and the board of trustees of the Interprofessional Commission of Ohio. Before any alteration of the endowment, every effort will be made to consult with heirs of the donors to be sure the donors' wishes are honored.

\$304,530.00

The E. W. Hatton Fund for Pediatric Pharmacy Research

The E. W. Hatton Fund for Pediatric Pharmacy Research was established on June 7, 2002, in accordance with the guidelines approved by the Board of Directors of The Ohio State University Foundation, with gifts from Isabel Hatton Simmons (B.S. 1931) of Columbus, Ohio, in honor of her father, Ellmore Wright Hatton, who was a pharmacist and co-owner of Hatton Pharmacy in Columbus, Ohio, at the turn of the twentieth century.

All gifts are to be invested by the Foundation, under the rules and regulations adopted by the Foundation's Board of Directors, with the right to invest and reinvest as occasion dictates.

The annual income shall be used to improve the effectiveness, safety, and use of medicines in pediatric and geriatric patients.

It is the desire of the donor that this fund should benefit the University in perpetuity. If the need for this fund should cease to exist or so diminish as to provide unused income, then another use shall be designated by the Foundation Board in consultation with the dean of the College of Pharmacy, and/or department chairperson in order to carry out the desire of the donor.

\$250,000.00

REPORT ON UNIVERSITY DEVELOPMENT (contd)

THE OHIO STATE UNIVERSITY FOUNDATION (contd)

Establishment of Named Endowed Funds (contd)

The Dr. Herbert L. Fenburr Fund for Human Cancer Genetics Research

The Dr. Herbert L. Fenburr Fund for Human Cancer Genetics Research for the Comprehensive Cancer Center – The Arthur G. James Cancer Hospital and Richard J. Solove Research Institute was established on June 7, 2002, in accordance with the guidelines approved by the Board of Directors of The Ohio State University Foundation, with a gift from Dorothy J. Fenburr (B.A. 1935) and Margaret F. Davenport in memory of Dr. Herbert Fenburr (B.Ch.E. 1934, M.S. 1935, Ph.D. 1937), beloved husband and father; Dr. John Minton (B.S. 1956, M.D. 1960, M.M.S. 1966, Ph.D. 1969); and in honor of Dr. James Niedhart.

All gifts are to be invested by the Foundation, under the rules and regulations adopted by the Foundation's Board of Directors, with the right to invest and reinvest as occasion dictates.

The annual income shall be used to support an endowed fund in human cancer genetics research at the Comprehensive Cancer Center – The Arthur G. James Cancer Hospital and Richard J. Solove Research Institute at The Ohio State University as approved by the director of the Comprehensive Cancer Center – The Arthur G. James Cancer Hospital and Richard J. Solove Research Institute, the director of the Comprehensive Cancer Center, and the senior vice president for Health Sciences and dean of the College of Medicine and Public Health. Any unused income shall be returned to the principal of this fund.

It is the desire of the donors that this fund should benefit the University in perpetuity. If the need for this fund should cease to exist or so diminish as to provide unused income, then another use shall be designated by the Foundation Board in consultation with the director of The Arthur G. James Cancer Hospital and Richard J. Solove Research Institute, the director of the Comprehensive Cancer Center, and the senior vice president for Health Sciences and dean of the College of Medicine and Public Health in order to carry out the desire of the donors.

\$232,477.48

The Evelyn Moreida Krislov Scholarship Fund

The Evelyn Moreida Krislov Scholarship Fund was established on June 7, 2002, in accordance with the guidelines approved by the Board of Directors of The Ohio State University Foundation, with a gift from Joseph Krislov, Lexington, Kentucky.

All gifts are to be invested by the Foundation, under the rules and regulations adopted by the Foundation's Board of Directors, with the right to invest and reinvest as occasion dictates.

The annual income shall be used for scholarships for second-year graduate students in the College of Social Work who have an interest in the field of aging. Second-year field placement with an aging agency shall be considered a primary indicator of interest in the field. The scholarship will be awarded in consultation with the University Committee on Student Financial Aid.

It is the desire of the donor that this fund should benefit the University in perpetuity. If the need for this fund should cease to exist or so diminish as to provide unused income, then another use shall be designated by the Foundation Board in consultation with the dean of the College of Social Work, and Marvin Krislov, son of Joseph and Evelyn Krislov, as long as he shall live, in order to carry out the desire of the donor.

\$103,049.12

REPORT ON UNIVERSITY DEVELOPMENT (contd)

THE OHIO STATE UNIVERSITY FOUNDATION (contd)

Establishment of Named Endowed Funds (contd)

The Kenneth B. Cummins Endowment Fund

The Kenneth B. Cummins Endowment Fund was established on June 7, 2002, in accordance with the guidelines approved by the Board of Directors of The Ohio State University Foundation, with gifts from Dr. Kenneth B. Cummins (Ph.D. 1958), New Washington, Ohio.

All gifts are to be invested by the Foundation, under the rules and regulations adopted by the Foundation's Board of Directors, with the right to invest and reinvest as occasion dictates.

The annual income shall be used to aid worthy undergraduate students pursuing the study of mathematics; or to aid worthy undergraduate students pursuing study in the College of Mathematical and Physical Sciences; or at the discretion of the department chairperson to purchase books or equipment that would otherwise enhance undergraduate instruction in the Department of Mathematics. When selecting students for scholarship aid, first preference should be given to students from the Buckeye Central School District or its reasonable successor. Second preference should be given to students from other schools in Crawford County. The administrator of the fund will be then current chairperson of the Department of Mathematics.

Scholarships will be awarded in consultation with the University Committee on Student Financial Aid.

It is the desire of the donor that this fund should benefit the University in perpetuity. If the need for this fund should cease to exist or so diminish as to provide unused income, then another use shall be designated by the Foundation Board in consultation with the appropriate college dean, department chairperson, or program administrative officer in order to carry out the desire of the donor.

\$63,596.65

The Family and Consumer Sciences Education Program Fund

The Family and Consumer Sciences Education Program Fund was established on June 7, 2002, in accordance with the guidelines approved by the Board of Directors of The Ohio State University Foundation, with gifts from Penelope A. Reighart (Ph.D. 1985) and alumni and friends of the College of Human Ecology.

All gifts are to be invested by the Foundation, under the rules and regulations adopted by the Foundation's Board of Directors, with the right to invest and reinvest as occasion dictates.

The annual income supports programs at The Ohio State University in the family and consumer sciences education area for the purpose of teacher preparation and licensure to teach in Ohio schools, grades seven through twelve. Uses may include: support for faculty, lecturers, administrative and professional staff, graduate associates, support staff, distinguished visitors assisting with the program, for general operating costs, and for special programs in family and consumer sciences education as identified by family and consumer sciences education directors, faculty, and staff members. In any given year that the endowment income is not fully expended, the unused portion should be reinvested in the endowment principal.

The fund will be directed by the dean of the College of Human Ecology, or designee, in consultation with the director and advisory committee of the family and consumer sciences education program.

REPORT ON UNIVERSITY DEVELOPMENT (contd)

THE OHIO STATE UNIVERSITY FOUNDATION (contd)

Establishment of Named Endowed Funds (contd)

The Family and Consumer Sciences Education Program Fund (contd)

It is the desire of the donors that this fund should benefit the University in perpetuity. If the need for this fund should cease to exist or so diminish as to provide unused income, then the fund shall be used for other teacher education programs administered by the University and other College of Human Ecology programs that provide formal and non-formal education in areas related to human ecology, such as those provided by the family and consumer sciences extension program, as designated by the Foundation Board in consultation with the dean and executive committee of the College of Human Ecology, in order to carry out the desire of the donors.

\$51,272.20

The Raymond W. Dосkotch Graduate Fellowship Fund
in Medicinal Chemistry and Pharmacognosy

The Raymond W. Dосkotch Graduate Fellowship Fund in Medicinal Chemistry and Pharmacognosy was established on June 7, 2002, in accordance with the guidelines approved by the Board of Directors of The Ohio State University Foundation, with gifts from Dr. Jinn (Ph.D. 1979) and Dr. Ze-Ai (Diana) Chang Wu (Ph.D. 1981) of Princeton Junction, New Jersey.

All gifts are to be invested by the Foundation, under the rules and regulations adopted by the Foundation's Board of Directors, with the right to invest and reinvest as occasion dictates.

The annual income shall be used to provide one graduate student fellowship to a student whose research emphasizes natural product chemistry (isolation, structure elucidation, chemical and/or biological modification, and biosynthesis) within the Division of Medicinal Chemistry and Pharmacognosy at the College of Pharmacy. The recipient of the annual award shall be determined by the chairperson of the division in consultation with the dean of the College of Pharmacy or his/her designee.

It is the desire of the donors that this fund should benefit the University in perpetuity. If the need for this fund should cease to exist or so diminish as to provide unused income, then another use shall be designated by the Foundation Board in consultation with the appropriate college dean, school director, department chairperson, or program administrative officer in order to carry out the desire of the donors.

\$45,000.00

The Edward F. Hayes Graduate Research Award Fund

The Edward F. Hayes Graduate Research Award Fund was established on June 7, 2002, in accordance with the guidelines approved by the Board of Directors of The Ohio State University Foundation, with gifts from friends and family in memory of Edward F. Hayes' (vice president for Research, 1991-1998) contributions to research and graduate education.

All gifts are to be invested by the Foundation, under the rules and regulations adopted by the Foundation's Board of Directors, with the right to invest and reinvest as occasion dictates.

The annual income shall be used to provide graduate research award(s) in conjunction with The Edward F. Hayes Graduate Research Forum. The fund will be administered by the Office of Research.

REPORT ON UNIVERSITY DEVELOPMENT (contd)

THE OHIO STATE UNIVERSITY FOUNDATION (contd)

Establishment of Named Endowed Funds (contd)

The Edward F. Hayes Graduate Research Award Fund (contd)

It is the desire of the donors that this fund should benefit the University in perpetuity. If the need for this fund should cease to exist or so diminish as to provide unused income, then another use shall be designated by the Foundation Board in consultation with the appropriate college dean, department chairperson, or program administrative officer in order to carry out the desire of the donors.

\$29,794.96

The Mollmann Family Cancer Research Endowment Fund

The Mollmann Family Cancer Research Endowment Fund for the Comprehensive Cancer Center – The Arthur G. James Cancer Hospital and Richard J. Solove Research Institute was established on June 7, 2002, in accordance with the guidelines approved by the Board of Directors of The Ohio State University Foundation, with a gift from Mr. and Mrs. Joe Mollmann of Columbus, Ohio.

All gifts are to be invested by the Foundation, under the rules and regulations adopted by the Foundation's Board of Directors, with the right to invest and reinvest as occasion dictates.

The annual income shall be used to support cancer research at the Comprehensive Cancer Center – The Arthur G. James Cancer Hospital and Richard J. Solove Research Institute at The Ohio State University as approved by the director of The Arthur G. James Cancer Hospital and Richard J. Solove Research Institute and the director of the Comprehensive Cancer Center, in consultation with the senior vice president for Health Sciences and dean of the College of Medicine and Public Health. Preference will be given to human cancer genetics research. Any unused income shall be returned to the principal of this fund.

It is the desire of the donors that this fund should benefit the University in perpetuity. If the need for this fund should cease to exist or so diminish as to provide unused income, then another use shall be designated by the Foundation Board in consultation with the director of The Arthur G. James Cancer Hospital and Richard J. Solove Research Institute, the director of the Comprehensive Cancer Center, and the senior vice president for Health Sciences and dean of the College of Medicine and Public Health in order to carry out the desire of the donors.

\$29,300.00

Belmont County Alumni Scholarship Endowed Fund

The Belmont County Alumni Scholarship Endowed Fund was established on June 7, 2002, in accordance with the guidelines approved by the Board of Directors of The Ohio State University Foundation, with gifts from members and friends of the Belmont County Alumni Club.

All gifts are to be invested by the Foundation, under the rules and regulations adopted by the Foundation's Board of Directors, with the right to invest and reinvest as occasion dictates.

The annual income shall be used to provide academic merit scholarships for entering freshman from high schools in Belmont County, with preference for students qualified under the alumni scholars program.

REPORT ON UNIVERSITY DEVELOPMENT (contd)

THE OHIO STATE UNIVERSITY FOUNDATION (contd)

Establishment of Named Endowed Funds (contd)

Belmont County Alumni Scholarship Endowed Fund (contd)

It is the desire of the donors that this fund should benefit the University in perpetuity. If the need for this fund should cease to exist or so diminish as to provide unused income, then another use shall be designated by the Foundation Board in consultation with the director of Financial Aid in order to carry out the desire of the donors.

\$27,168.13

The Robert Godfrey Arend Family Football Scholarship Fund

The Robert Godfrey Arend Family Football Scholarship Fund was established on June 7, 2002, in accordance with the guidelines approved by the Board of Directors of The Ohio State University Foundation, with gifts from Robert Godfrey Arend (B.S.Bus.Adm. 1952, M.B.A. 1956) and children, Todd (B.S.Bus.Adm. 1990) and Maria Arend, and granddaughters, Katherine Elizabeth and Alexandria Grace Arend.

All gifts are to be invested by the Foundation, under the rules and regulations adopted by the Foundation's Board of Directors, with the right to invest and reinvest as occasion dictates.

The annual income shall be used to supplement the student-athlete grant-in-aid scholarship costs of a student athlete from Northeastern Ohio who is a member of the varsity football team pursuing an undergraduate degree at The Ohio State University. The director of Athletics will select the recipient in consultation with the University Committee on Student Financial Aid.

It is the desire of the donors that this fund should benefit the University in perpetuity. If the need for this fund should cease to exist or so diminish as to provide unused income, then another use shall be designated by the Foundation Board as recommended by the director of Athletics in order to carry out the desire of the donors.

\$26,489.36

The Charles and Betty Dougherty Scholarship Fund

The Charles and Betty Dougherty Scholarship Fund was established on June 7, 2002, in accordance with the guidelines approved by the Board of Directors of The Ohio State University Foundation, with a gift from Charles and Betty Dougherty of Wooster, Ohio.

All gifts are to be invested by the Foundation, under the rules and regulations adopted by the Foundation's Board of Directors, with the right to invest and reinvest as occasion dictates.

The annual income shall be used to award scholarships to students enrolled in the fluid power or power and equipment program at The Ohio State University Agricultural Technical Institute in Wooster, Ohio. The scholarships shall be awarded in consultation with the University Committee on Student Financial Aid and a representative selected by the Dougherty family. Unused funds shall be reinvested into the principal.

It is the desire of the donors that this fund should benefit the University in perpetuity. If the need for this fund should cease to exist or so diminish as to provide unused income, then another use shall be designated by the Foundation Board in consultation with the director of The Ohio State University Agricultural Technical Institute in order to carry out the desire of the donors.

\$25,590.75

REPORT ON UNIVERSITY DEVELOPMENT (contd)

THE OHIO STATE UNIVERSITY FOUNDATION (contd)

Establishment of Named Endowed Funds (contd)

The Bruce W. Erickson Distinguished Scholar Fund

The Bruce W. Erickson Distinguished Scholar Fund was established on June 7, 2002, in accordance with the guidelines approved by the Board of Directors of The Ohio State University Foundation, with gifts through the Nanette N. (B.S. 1965 – cum laude, B.S. 1967 – cum laude) and Robert M. (B.S. 1965, M.B.A. 1966) Hoge Fund at the Columbus Foundation in memory of Bruce W. Erickson (B.S. 1963).

All gifts are to be invested by the Foundation, under the rules and regulations adopted by the Foundation's Board of Directors, with the right to invest and reinvest as occasion dictates.

The annual income shall be used to provide a scholarship for a distinguished scholar enrolled in the College of Mathematical and Physical Sciences. The recipient will be selected through the University's program to recruit high ability students and each recipient will continue through the senior year so long as he or she maintains eligibility as a distinguished scholar. This fund shall be administered by the University Honors and Scholars Center in cooperation with the College of Mathematical and Physical Sciences and in consultation with the University Committee on Student Financial Aid.

It is the desire of the donors that this fund should benefit the University in perpetuity. If the need for this fund should cease to exist or so diminish as to provide unused income, then another use shall be designated by the Foundation Board in consultation with the appropriate college dean, department chairperson, or program administrative officer in order to carry out the desire of the donors.

\$25,000.00

The Kelm Family Engineering Scholarship Fund

The Kelm Family Engineering Scholarship Fund was established on June 7, 2002, in accordance with the guidelines approved by the Board of Directors of The Ohio State University Foundation, with a gift from Sharon Simon Kelm (B.S.Ed. 1973 – cum laude) and James S. Kelm (B.S.A.A.E. 1971).

All gifts are to be invested by the Foundation, under the rules and regulations adopted by the Foundation's Board of Directors, with the right to invest and reinvest as occasion dictates.

The annual income shall provide one or more merit scholarships to students majoring in engineering. Selection will be made by the dean of the College of Engineering in consultation with the University Committee on Student Financial Aid. Recipients must be U.S. citizens.

It is the desire of the donors that this fund should benefit the University in perpetuity. If the need for this fund should cease to exist or so diminish as to provide unused income, then another use shall be designated by the Foundation Board in consultation with the appropriate college dean in order to carry out the desire of the donors.

\$25,000.00

The William and Phyllis Kraner Athletic Scholarship Fund

The William and Phyllis Kraner Athletic Scholarship Fund was established on June 7, 2002, in accordance with the guidelines approved by the Board of Directors of The Ohio State University Foundation, with gifts from the Kraner family of Newark, Ohio.

REPORT ON UNIVERSITY DEVELOPMENT (contd)

THE OHIO STATE UNIVERSITY FOUNDATION (contd)

Establishment of Named Endowed Funds (contd)

The William and Phyllis Kraner Athletic Scholarship Fund (contd)

All gifts are to be invested by the Foundation, under the rules and regulations adopted by the Foundation's Board of Directors, with the right to invest and reinvest as occasion dictates.

The annual income shall be used to provide scholarship cost of a student athlete who is a member of a varsity sports team pursuing an undergraduate degree at The Ohio State University. The recipient shall be selected by the director of Athletics in consultation with the University Committee on Student Financial Aid.

It is the desire of the donors that this fund should benefit the University in perpetuity. If the need for this fund should cease to exist or so diminish as to provide unused income, then another use shall be designated by the Foundation Board as recommended by the director of Athletics in order to carry out the desire of the donors.

\$25,000.00

The Sheffer Corporation Dean's Innovation Fund

The Sheffer Corporation Dean's Innovation Fund was established on June 7, 2002, in accordance with the guidelines approved by the Board of Directors of The Ohio State University Foundation, with gifts from Jeffrey R. Norris (B.S.Bus.Adm. 1986) of Cincinnati, Ohio, and the Sheffer Corporation.

All gifts are to be invested by the Foundation, under the rules and regulations adopted by the Foundation's Board of Directors, with the right to invest and reinvest as occasion dictates.

The annual income shall be used by the dean of The Max M. Fisher College of Business to promote initiatives by the faculty and staff designed to increase the quality of teaching, research, and involvement with the business community.

It is the desire of the donor that this fund should benefit the University in perpetuity. If the need for this fund should cease to exist or so diminish as to provide unused income, then another use shall be designated by the Foundation Board as recommended by the dean of Fisher College of Business in order to carry out the desire of the donor.

\$25,000.00

Frederick A. Smith Memorial Scholarship Fund

The Frederick A. Smith Memorial Scholarship Fund was established on June 7, 2002, in accordance with the guidelines approved by the Board of Directors of The Ohio State University Foundation, with gifts from his wife, Denise Smith, and his parents, Mr. and Mrs. Joseph R. Smith, all of Eaton, Ohio, and family and friends.

Frederick A. Smith graduated with a Bachelor of Science in Welding Engineering degree in 1981; was president of Rexarc International Inc., West Alexandria, Ohio; an avid trap shooter; and a volunteer in community activities. Mr. Smith was born February 5, 1958, and died July 21, 2001.

All gifts are to be invested by the Foundation, under the rules and regulations adopted by the Foundation's Board of Directors, with the right to invest and reinvest as occasion dictates.

REPORT ON UNIVERSITY DEVELOPMENT (contd)

THE OHIO STATE UNIVERSITY FOUNDATION (contd)

Establishment of Named Endowed Funds (contd)

Frederick A. Smith Memorial Scholarship Fund (contd)

The annual income shall be used to support renewable scholarships for one or more deserving welding engineering students including middle income and working students from Ohio with preference for students who have had previous education in a technical school. Selection shall be made by the chairperson of the undergraduate welding engineering program in cooperation with the University Committee on Student Financial Aid.

It is the desire of the donors that this fund should benefit the University in perpetuity. If the need for this fund should cease to exist or so diminish as to provide unused income, then another use shall be designated by the Foundation Board in consultation with the dean of the College of Engineering or department chairperson in order to carry out the desire of the donors.

\$25,000.00

The Donald E. Yingst Agricultural Vice President's Fund

The Donald E. Yingst Agricultural Vice President's Fund was established on June 7, 2002, in accordance with the guidelines approved by the Board of Directors of The Ohio State University Foundation, with gifts from Donald E. Yingst (B.S. 1962, M.S. 1964) of Dublin, Ohio.

All gifts are to be invested by the Foundation, under the rules and regulations adopted by the Foundation's Board of Directors, with the right to invest and reinvest as occasion dictates.

The annual income shall be used to support programs identified by the vice president for Agricultural Administration and University Outreach, and executive dean for Food, Agricultural, and Environmental Sciences as current and critical priorities in the College of Food, Agricultural, and Environmental Sciences. Uses of the fund shall include, but not be limited to support of: positive, creative work environment for students, faculty and staff; "outreach" to our external audiences; encouragement and promotion of student organizations; scholarships; professional development; college promotion and advancement; and other emerging college priorities. Scholarships will be awarded in consultation with the University Committee on Student Financial Aid.

It is the desire of the donor that this fund should benefit the University in perpetuity. If the need for this fund should cease to exist or so diminish as to provide unused income, then another use shall be designated by the Foundation Board in consultation with the vice president for Agricultural Administration and University Outreach, and executive dean for Food, Agricultural, and Environmental Sciences, or their successor in order to carry out the desire of the donor.

\$25,000.00

Change in Description of Named Endowed Fund

The Griffith Family Scholarship Endowment Fund

The Griffith Family Scholarship Endowment Fund was established April 6, 2001, in accordance with the guidelines approved by the Board of Directors of The Ohio State University Foundation, with gifts from William David (B.S. 1961), Phyllis Ann (B.S. 1962), Thomas Edward (B.S.Agr. 1991 – summa cum laude), and William Douglas Griffith (B.S.Agr. 1988), Ada, Ohio. The description was revised on June 7, 2002.

REPORT ON UNIVERSITY DEVELOPMENT (contd)

THE OHIO STATE UNIVERSITY FOUNDATION (contd)

Change in Description of Named Endowed Fund (contd)

The Griffith Family Scholarship Endowment Fund (contd)

All gifts are to be invested by the Foundation, under the rules and regulations adopted by the Foundation's Board of Directors, with the right to invest and reinvest as occasion dictates.

The annual income shall be used to support students who are enrolled in the College of Food, Agricultural, and Environmental Sciences, including incoming freshman. First preference shall go to a student from Hardin County; second preference shall go to any student in the College who resides in any county adjacent to Hardin County. Selection will be based on scholastic achievement, leadership, and community service with preference given for financial need. Recipients shall be selected by the Hardin County Alumni Association in consultation with the University Committee on Student Financial Aid. In any given year that the endowment income is not fully expended, the unused portion should be reinvested in the endowment principal.

It is the desire of the donors that this fund should benefit the University in perpetuity. If the need for this fund should cease to exist or so diminish as to provide unused income, then another use shall be designated by the Foundation Board in consultation with the vice president for Agricultural Administration and University Outreach, and executive dean for Food, Agricultural, and Environmental Sciences, or their successor, or an appropriate administrative officer, or their successor, in order to carry out the desire of the donors.

Change in Name and Description of Named Endowed Fund

The Harold Brenner Pepinsky Early Career Award Fund
in Neurobehavioral Science

The Harold Brenner Pepinsky Research and Lectureship Fund was established on April 3, 1998, in accordance with the guidelines approved by the Board of Directors of The Ohio State University Foundation with gifts from Pauline Nichols Pepinsky, Ph.D., of Worthington, Ohio, in honor of her late husband, Harold Brenner Pepinsky, professor emeritus of the Department of Psychology. The name and description were revised on June 7, 2002.

All gifts are to be invested by the Foundation, under the rules and regulations adopted by the Foundation Board of Directors with the right to invest and reinvest as occasion dictates.

The annual income shall support awards for outstanding contributions to knowledge in the areas of cognitive neurology and neurodegenerative disorders by investigators still in the early stages of their careers, being no more than nine years beyond completion of their advanced degrees (M.D. or Ph.D.) or postgraduate training. Priority shall be given to candidates engaged in interdisciplinary projects, and recipients may be, but are not restricted to, researchers based at The Ohio State University. The awards are to be presented annually or biennially, at a planned event, when the recipient will be given a special honorarium and also will be expected to present a paper focused on his (or her) current work.

Selection shall be made by an awards committee whose members shall be appointed by the associate dean for Research and/or the senior vice president for Health Sciences and dean of the College of Medicine and Public Health, and should include faculty representing relevant areas of study. The committee each year shall determine the number and amount of awards, as income allows. The income will support a financial award, travel expenses and other associated award expenses. Selection of the recipient shall be made in consultation with the chairperson of the Department of Neurology and the senior vice president for Health Sciences and dean of the College of Medicine and Public Health.

REPORT ON UNIVERSITY DEVELOPMENT (contd)

THE OHIO STATE UNIVERSITY FOUNDATION (contd)

Change in Name and Description of Named Endowed Fund (contd)

The Harold Brenner Pepinsky Early Career Award Fund
in Neurobehavioral Science (contd)

It is the desire of the donor that this fund should benefit the University in perpetuity. If the need for this fund should cease to exist or so diminish as to provide unused income, then another use shall be designated by the Board of Trustees in consultation with the chairperson of the Department of Neurology and the senior vice president for Health Sciences and dean of the College of Medicine and Public Health in order to carry out the desire of the donor.

**EMPLOYMENT OF ARCHITECTS/ENGINEERS,
EMPLOYMENT OF CONSTRUCTION MANAGER, AND
REQUEST FOR CONSTRUCTION BIDS**

Resolution No. 2002-147

LABORATORY ANIMAL FACILITIES
PRIOR HEALTH SCIENCES LIBRARY BASEMENT RENOVATION
MEILING HALL LOBBY EXPANSION
DESIGN SERVICES FOR THE JOB ORDER CONTRACT PROGRAM

Synopsis: Authorization to employ architect/engineering firms for the Laboratory Animal Facilities and Design Services for the Job Order Contract Program projects, employ a construction manager for the Laboratory Animal Facilities project, and employ architectural/engineering firms and request construction bids for the Prior Health Sciences Library Basement Renovation and Meiling Hall Lobby Expansion projects is requested.

WHEREAS the University desires to construct an addition to Wiseman Hall that will connect to the new Biomedical Research Tower and provide additional space for the University Laboratory Animal Resources Department; and

WHEREAS the preliminary estimated total project cost is approximately \$15,750,000 and the total preliminary estimated construction cost is \$11,500,000, with funding provided by future capital appropriations (\$6,500,000), National Institute of Health Grant (\$1,050,000), and future University bond proceeds (\$8,200,000) with debt service paid by the Laboratory Animal Resources Department; and

WHEREAS the University desires to renovate space in the basement of the Prior Health Sciences Library to accommodate a Clinical Skills Lab to teach clinical skills for the College of Medicine and Public Health; and

WHEREAS the total estimated project cost is \$1,000,000 and the total estimated construction cost is \$800,000, with funding provided by the College of Medicine and Public Health; and

WHEREAS the University desires to renovate the lobby area on the first floor of Meiling Hall to create additional offices for the College of Medicine and Public Health; and

WHEREAS the total estimated project cost is \$750,000 and the total estimated construction cost is \$600,000, with funding provided by the College of Medicine and Public Health; and

**EMPLOYMENT OF ARCHITECTS/ENGINEERS,
EMPLOYMENT OF CONSTRUCTION MANAGER, AND
REQUEST FOR CONSTRUCTION BIDS (contd)**

WHEREAS the University desires to employ up to six architectural/engineering firms to provide design services on various small projects to be accomplished through the Job Order Contract Program and other procurement methods, and the firms selected will be from a variety of disciplines and expertise in order to provide qualified services for all types of projects and each project greater than \$200,000 will be presented to the Board of Trustees for approval prior to proceeding with construction; and

WHEREAS the fees for these services will be negotiated on a project by project basis based on the standard fee percentage approved by the State of Ohio:

NOW THEREFORE

BE IT RESOLVED, That the President and/or Senior Vice President for Business and Finance be authorized to select qualified architectural/engineering firms as necessary for the Prior Health Sciences Library Basement Renovation, Meiling Hall Lobby Expansion, and Design Services for Job Order Contract Program projects and that the fees for these services be negotiated between the firms selected and the University; and

BE IT FURTHER RESOLVED, That the President and/or Senior Vice President for Business and Finance be authorized to select qualified architectural/engineering firms and a qualified construction manager firm as necessary for the Laboratory Animal Facilities project and that the fees for these services be negotiated between the firms selected and the University, provided that no authorization to request construction bids for this project is to be submitted to the Board for approval until there is a signed memorandum of understanding, including an approved business plan and final cost estimates, among all the offices involved; and

BE IT FURTHER RESOLVED, That the President and/or Senior Vice President for Business and Finance be authorized to request construction bids for the Prior Health Sciences Library Basement Expansion and Meiling Hall Lobby Expansion projects in accordance with established University and State of Ohio procedures, and if satisfactory bids are received, to issue contracts with all actions to be reported to this Board at the appropriate time.

(See Appendix LI for background material and maps, page 1267.)

ACCEPTANCE OF A GIFT OF REAL PROPERTY

Resolution No. 2002-148

MELLINGER FARM
325.88 ACRES LOCATED IN JEFFERSON, OHIO

Synopsis: Authorization for the acceptance of a gift of approximately 326 acres of improved and unimproved property located in Jefferson, Ohio, and owned by Patricia Quinby and the Estate of Virginia Miller Reed, is proposed.

WHEREAS the Board of Trustees of The Ohio State University is presented with the opportunity to accept the generous gift of the Mellinger Farm, consisting of 325.88 acres, located at 6723, 6831, and 6855 Old Lincoln Way in Jefferson, Ohio; and

WHEREAS this gift will be made pursuant to a gift agreement dated 15 May 2002, and will consist of a gift of an undivided one-half interest in the property from the Estate of Virginia Miller Reed, which gift will be made through The Ohio State University Foundation, and gifts made over a period of time of the undivided one-half interest of Patricia Quinby; and

ACCEPTANCE OF A GIFT OF REAL PROPERTY (contd)

WHEREAS the property will be subject to an easement to ensure that the property remains dedicated to agricultural use, and the property will be used by the University's Ohio Agricultural Research and Development Center for development of a long-term research, education, and demonstration program for integrated systems of forestry, crops, and livestock, and OARDC will be responsible for all costs associated with the acquisition, operation, and maintenance of this property; and

WHEREAS the property has an appraised value of \$1,170,000; and

WHEREAS the appropriate University offices have determined that the acceptance of the gift of this property is in the best interest of the University:

NOW THEREFORE

BE IT RESOLVED, That the President and/or Senior Vice President for Business and Finance be authorized to accept the gift of this property, to be made as described above, and to acquire title to this property in the name of the State of Ohio for the use of The Ohio State University, in accordance with the gift agreement between the Estate of Virginia Miller Reed, Patricia Quinby, The Ohio State University Foundation, and The Ohio State University, and such other terms and conditions as are deemed to be in the best interest of the University.

(See Appendix LII for background material and map, page 1273.)

FISCAL YEAR 2001-02 THIRD QUARTER BUDGET REPORT

Resolution No. 2002-149

Synopsis: The third quarter budget report for fiscal year 2001-02 is being submitted for adoption.

WHEREAS the State of Ohio has cut FY 2002 funding to State assisted institutions of higher education, resulting in a \$19.4 million (6.0%) reduction in the Columbus Campus State Share of Instruction and a \$28.3 million overall reduction in all line items for all Campuses: and

WHEREAS the University's enrollments for all quarters are now known, allowing for a more accurate picture of the University's student fee revenue; and

WHEREAS other revenues such as Indirect Cost Recoveries on sponsored programs have been projected higher than originally budgeted; and

WHEREAS appropriate planning and consultation within the University has been accomplished and the President now recommends approval of the third quarter budget report:

NOW THEREFORE

BE IT RESOLVED, That the appropriate resources budgets be adjusted to reflect these changes as of the third quarter as described in the attached materials.

(See Appendix LIII for background material, page 1275.)

**2002-03 GRADUATE AND PROFESSIONAL STUDENT TUITION AND
LEARNING TECHNOLOGY FEE INCREASES**

Resolution No. 2002-150

Synopsis: Instructional, General and Nonresident fees for Graduate and Professional students and the Learning Technology fees for Fiscal Year 2002-03 are proposed.

WHEREAS the Board of Trustees of The Ohio State University approved the Columbus Campus Undergraduate Instructional and General fees to be effective Summer Quarter at their April meeting; and

WHEREAS the Board of Trustees approved the Agricultural Technical Institute and Regional Campus undergraduate instructional and general fees net of Access Challenge credits as well as the undergraduate nonresident surcharges at all campuses effective Summer Quarter at their May meeting; and

WHEREAS the professional colleges have now completed consultations with their students in regards to the level of their instructional fees above a 5% base to be used by those colleges to improve services to their students; and

WHEREAS the Learning Technology fees for specific colleges need to be approved for FY 2002-03.

NOW THEREFORE

BE IT RESOLVED, That the Graduate Instructional fees for all campuses be increased 5.0% (\$102 per quarter for a full-time student), effective Autumn Quarter 2002; and

BE IT FURTHER RESOLVED, That the General Fees for all graduate and professional students at the Columbus Campus will be the same as for undergraduates (\$120 per quarter and \$180 per semester for a full-time student), effective Autumn Quarter 2002; and

BE IT FURTHER RESOLVED, That the Nonresident Surcharges for all graduate and professional students at the Columbus Campus will increase 5.0% in accordance with the attached budget materials, effective Autumn Quarter 2002; and

BE IT FURTHER RESOLVED, That Differential (Instructional) Fees for the Professional Colleges and specific graduate programs at the Columbus Campus be increased in accordance with the attached budget materials, effective Autumn Quarter 2002, including three new graduate differential fees in the College of Medicine and Public Health for Health Administration, Public Health MPH and Public Health PEP; and

BE IT FURTHER RESOLVED, That the Learning Technology fees in place for specific colleges and programs at the Columbus Campus will not increase for FY 2003 and that no new Learning Technology fees will be introduced in FY 2003 in accordance with the attached budget materials.

(See Appendix LIV for background material, page 1281.)

INTERIM BUDGET FOR FISCAL YEAR 2002-2003

Resolution No. 2002-151

Synopsis: Authorization to make expenditures in Fiscal Year 2002-2003 is proposed.

WHEREAS having approved student fee increases and the compensation budget, the University has not yet finalized its operating budget for Fiscal Year 2002-2003; and

INTERIM BUDGET FOR FISCAL YEAR 2002-2003 (contd)

WHEREAS it is necessary to continue University expenditures, including payment of faculty and staff, prior to the time that the Current Funds Budget for Fiscal Year 2002-2003 is developed and adopted:

NOW THEREFORE

BE IT RESOLVED, That the University be authorized to make expenditures consistent with the level of resources approved for Fiscal Year 2001-2002, pending the adoption of the Current Funds Budget for Fiscal Year 2002-2003.

**ADDITIONAL FUNDING FOR THE SCIENCE AND TECHNOLOGY
CAMPUS CORPORATION**

Resolution No. 2002-152

Synopsis: Authorization for additional funding for the Science and Technology Campus Corporation ("SciTech"), is proposed.

WHEREAS in December 1997 the Board of Trustees of The Ohio State University authorized the University to enter into a Development Agreement, and leases of improved and unimproved land as provided for in that Agreement, with the Science and Technology Campus Corporation ("SciTech") for the development of an enhanced University Science and Technology Campus; and

WHEREAS in August 2000, the Board of Trustees approved the revised comprehensive development plan submitted by SciTech and authorized the University to extend, for an additional three-year period, the term of the Development Agreement and the leases of improved and unimproved land, and authorized the University to provide operating support not to exceed \$300,000 per year for the years 2001-02 and 2002-03, premised on the understanding that SciTech will continue to receive appropriate sustained support from the City of Columbus and the State of Ohio; and

WHEREAS the Development Agreement provides for a development loan by the University in an amount not to exceed \$21 million, and in December 1997 the Board of Trustees authorized a loan to SciTech of \$7 million, and that \$7 million has been used to construct Science Village at 1381 Kinnear Road, rehabilitate a significant amount of space at 1275 Kinnear Road, make improvements at 1224 Kinnear Road, and reserve a portion of the funds for ongoing infrastructure improvements in the Science and Technology Campus; and

WHEREAS SciTech now wishes to borrow the remaining \$14 million for the next phase of development of the Science and Technology Campus, including a new facility, near the existing ElectroScience Laboratory, to house a mix of academic and technology tenants; and

WHEREAS SciTech has done a remarkable job in this initial period in planning and implementing significant facility improvements, providing for the careful stewardship of University property, undertaking programs and initiatives to support and enhance the success of the Science and Technology Campus, and securing cooperative support from the City of Columbus and the State of Ohio in these efforts:

NOW THEREFORE

BE IT RESOLVED, That, in addition to the \$7 million loan already authorized, the University is hereby authorized to loan to SciTech an additional amount not to exceed \$14 million, so long as

**ADDITIONAL FUNDING FOR THE SCIENCE AND TECHNOLOGY
CAMPUS CORPORATION (contd)**

no more than \$10 million of those \$14 million are not secured by signed tenant lease commitments, with the total amount of the additional loan, plus accrued interest, to be repaid, in annual payments in accordance with an approved payment schedule, within 25 years of the date of the loan, provided that, as alternative financing is obtained for this new facility, SciTech promptly shall repay the equivalent amount of the loan from the University, with accrued interest; and

BE IT FURTHER RESOLVED, That, subject to approval by the appropriate University offices of a siting study and a business plan for the new facility described above, the University is hereby authorized to lease to SciTech the necessary amount of real property, on the north side of Kinnear Road in the vicinity of the ElectroScience Lab, for this new facility; and

BE IT FURTHER RESOLVED, That the additional development loan and the additional lease of land for the new facility authorized by this resolution shall be subject to the terms and conditions of the Development Agreement of May 1998 and subject to such amendments of that Agreement as are necessary to protect the best interests of the University and provide for the new loan and the new lease of land in a manner similar to that provided in the Agreement for the previous loan and existing leases.

UNIVERSITY MEMBERSHIP IN UNIVERSITY HEALTHSYSTEM CONSORTIUM, INC.

Resolution No. 2002-153

Synopsis: Confirmation of the participation of the Vice President for Health Services on the Board of Directors of the University HealthSystem Consortium is proposed.

WHEREAS in Resolution 87-39 the Board of Trustees of The Ohio State University authorized the University, on behalf of University Hospitals, to join the University Hospital Consortium, Inc., and to participate in joint purchasing activities through this Consortium; and

WHEREAS in Resolution 98-62 the Board of Trustees reconfirmed Resolution 87-39 and authorized the Associate Vice President for Health Sciences and Executive Director of University Hospitals, on a continuing basis, to purchase equipment, materials, supplies, or services through the University Hospital Consortium; and

WHEREAS the Associate Vice President for Health Sciences and Executive Director of University Hospitals also has participated as a member of the Board of Directors of the University Hospital Consortium, now known as the University HealthSystem Consortium, and, as a member of that Board of Directors, has represented University Hospitals and its interests; and

WHEREAS it is in the best interest of the University to continue its membership in the University HealthSystem Consortium by appointing the Vice President for Health Services to continue service as a member of the Board of Directors of the University HealthSystem Consortium in order to represent the University and its Health System;

NOW THEREFORE

BE IT RESOLVED, That the Board of Trustees hereby reconfirms Resolutions 87-39 and 98-62 and, so long as there is no conflict of interest, authorizes and directs the Vice President for Health Services and the holder of any successor office to continue to serve as a member of the Board of Directors of the University HealthSystem Consortium and, in that capacity, to represent the

UNIVERSITY MEMBERSHIP IN UNIVERSITY HEALTHSYSTEM CONSORTIUM, INC. (contd)

interests of the University and its Health System as part of his or her official responsibilities to the University, entitling him or her to any immunity, insurance, or indemnity protection to which employees of the University are, or hereafter may become, entitled.

Upon motion of Ms. Hendricks, seconded by Mr. McFerson, the Board of Trustees adopted the foregoing resolutions by unanimous roll call vote, cast by Messrs. Patterson, Sofia, Slane, McFerson, Borrer, and Judge Duncan, Mses. Longaberger, Hendricks, and Davidson.

--0--

DISTINGUISHED UNIVERSITY PROFESSOR AWARDS

President William E. Kirwan:

We will now proceed with the designation of two faculty members as Distinguished University Professors.

As you know, this is the highest honor we can confer upon our faculty. The twenty-six faculty members who have been honored as Distinguished University Professors, including the two we are recognizing today, represent the highest standards of excellence in teaching, scholarship, and service at The Ohio State University.

To give you some sense of how special this honor is, we have more than 3,000 faculty at The Ohio State University, and as I just said, including today, we have twenty-six Distinguished University Professors. That represents less than one percent of our total faculty. This means that we are honoring and recognizing faculty today whose contributions to knowledge and scholarship compare to the best faculty at any university in the world. It is a very rigorous process by which these people earn this designation. The process is done through the Office of Academic Affairs through rigorous criteria and recommendations based on a panel of previously appointed Distinguished University Professors.

We're going to recognize today, Professor Linda Saif from the Food Animal Research Program at the Ohio Agricultural Research and Development Center (OARDC) in Wooster, and the Department of Veterinary Preventive Medicine. We're also recognizing Professor Lonnie G. Thompson from the Department of Geological Sciences and research scientist at the Byrd Polar Research Center.

I would like to call upon Provost Ed Ray, who has been so intimately involved in this process, and in these recommendations. Ed --

Provost Edward J. Ray:

Thank you, Mr. President. As you indicated, the title of Distinguished University Professor is the highest honor that the University confers on a faculty member and, as the president noted, since its inception in 1986, only twenty-six faculty have ever received this prestigious distinction. Faculty are nominated by University colleagues, and nominations are supported by national and international experts in their fields of research. All nominations are reviewed by a panel of distinguished faculty colleagues who make the final decision.

The selection committee chose two distinguished colleagues for this permanent honorific title: Professor Linda J. Saif, from the Food Animal Research Program at the Ohio Agricultural Research and Development Center on the Wooster Campus and the Department of Veterinary Preventive Medicine; and Professor Lonnie G. Thompson, from the Department of Geological Sciences and the Byrd Polar Research Center.

DISTINGUISHED UNIVERSITY PROFESSOR AWARDS (contd)

Provost Ray: (contd)

Distinguished University Professors receive an award of \$10,000 a year for a period of three years from the Office of Academic Affairs to be used to support their academic work. I will speak briefly about each honoree and then invite them to step forward for the conferment of the title.

I'm pleased to recommend Professor Linda J. Saif for the designation Distinguished University Professor. Dr. Saif's work reflects the very highest standards of excellence for research, teaching, and service. Dr. Saif is credited with discovering the potential for enteric viral infections in animals to infant human populations in epidemic proportions.

A member of the National Academy of Sciences wrote:

"Dr. Saif is the world's foremost authority on the immune response of newborns to intestinal infections."

Professor Saif is recognized internationally for her research in the identification of novel intestinal viruses and developing diagnostic tests and research methods for working with them in the laboratory, and vaccines for their control. Her research has been innovative, a first in the field, and used extensively by practitioners and others to prevent and control these important enteric diseases.

I would also like to recommend Professor Lonnie G. Thompson, from the Department of Geological Sciences for the designation of Distinguished University Professor. Dr. Thompson's work reflects the very highest standard of excellence for research, teaching, and service. Professor Thompson is unable to be with us today because he is on an expedition in Alaska. His co-principle investigator Professor Ellen Mosley-Thompson, from the Department of Geography, will accept the award for him.

A professor at Columbia University wrote that Professor Thompson is,

"... arguably the most productive scientist in the earth and environmental sciences ...," and that, "... he ranks in the top five most influential scientists studying the history of the earth's climate system."

Time Magazine also named Professor Thompson as one of the top scientists in the world today.

Professor Thompson has become one of our leading national spokespersons on the subject of global climate change, and is one of the most respected voices in the world on policy issues such as the Kyoto Protocol. His work will influence the future of the planet and every one of its inhabitants.

Would Professor Saif and Professor Mosley-Thompson please step forward, and would you all please join me in congratulating Professor Saif and Professor Thompson.

Now, I'd like to invite Dean Glen Hoffsis, from the College of Veterinary Medicine, to say a few words.

Dean Glen F. Hoffsis:

Thank you, Provost Ray. Mr. Chairman, Mr. President, and members of the Board, it's my distinct pleasure to be able to introduce Dr. Linda Saif.

DISTINGUISHED UNIVERSITY PROFESSOR AWARDS (contd)

Dean Hoffsis: (contd)

In many ways, this award is recognition of a longstanding collaborative relationship between the Colleges of Food, Agricultural, and Environmental Sciences, and Veterinary Medicine, and I'd like to thank Vice President Moser for all of his support through the years. Also, Dr. Saif is a professor in the College of Veterinary Medicine, but all of her work, as you've heard, has been done at OARDC, and I'd like to recognize Dr. Steve Slack, the director of OARDC. Her work at OARDC is in the Food Animal Health Research Program, which is headed by Dr. Mo Saif. That is a part of the Department of Veterinary Preventive Medicine in our college, and the chair of that department is Dr. Kent Hoblet.

So now that I seem to have given away all of the credit, I want to focus on where the credit really is due. As you've heard, Dr. Saif works on intestinal viruses, and these are very important agents in both animals and people. Therefore, her work is supported by the National Institute of Health, as well as the USDA and several of the industries involved. As a measure of the magnitude of her work, she currently is funded at the level of about \$1.75 million per year. This is an astounding number, not only because it supports a very robust research program, but also it attests to the quality of the work because these are very competitive agencies with all peer reviewed grant proposals. So, it's really quite an astounding accomplishment.

She is also an effective teacher, having completed some 30 graduate students since she began on the faculty in 1976. She has received several other honors: she is a recipient of the OSU Distinguished Professor Award, a fellow of the American Association for the Advancement of Science, and was recently elected president of the Conference of Research Workers in Animal Disease in North America.

On a personal note, Dr. Saif is interesting because she grew up in Central Ohio. She attended Wooster College, did all of her graduate work at Ohio State, and has completed her entire academic career at Ohio State. Yet, she is known and has spoken around the world on her research. Professionally, she is known as a critical, driven taskmaster. On a personal level, she is an engaging and charming person who likes to discuss her family, farm, and children.

Our college was founded 117 years ago, and we've been on a quest for excellence ever since. Our first Distinguished University Professor Award was granted just last year to Dr. Charles Capen, and now we have Dr. Saif. So the trend line is established, and I've told our faculty that I will expect one of these awards every year from now on.

Congratulations, Dr. Saif.

Provost Ray:

Professor Saif, would you like to say a few words?

Professor Linda J. Saif:

Yes. Well, I'm certainly humbled and very, very honored by this award. I'd just like to review a little bit about my long-term relationship with The Ohio State University.

As Glen mentioned, I am a native Buckeye and alumna of The Ohio State University. I grew up in the shadow of OSU and graduated from New Albany

DISTINGUISHED UNIVERSITY PROFESSOR AWARDS (contd)

Professor Saif: (contd)

High School, and this was before the white fences of the New Albany Company crisscrossed our rural landscape. My first field science experience was actually wading in the Rocky Fork Creek behind our house -- that maybe some of you are familiar with -- with my brother and sister, and lifting stones to see what unusual creatures they harbored underneath. Using a microscope to view a drop of water from the creek, I remember vividly my first encounter with the fascinating and varied life forms of a previously unimagined miniature world.

Although most people are advised to think big I continue to think small, and decided on a career in microbiology. This decision resulted in part from my hands-on laboratory experience at OARDC as part of the independent study program of the College of Wooster. Thus, I remain a very strong proponent of hands-on undergraduate research experiences as a way to introduce talented students to future career opportunities. I applaud Ohio State for going in this direction. Both then and now, I find laboratory research exciting, stimulating, rewarding – often frustrating, but always new and challenging.

As a graduate student, I first observed the footprints left by viruses in the cells and tissues they destroyed and saw the devastating diseases that they caused in both humans and animals. Again, my first glimpse of a real virion was through the electron microscope here in Graves Hall at OSU. This was my telescope that I used to observe a nano cosmos containing the Lilliputian world of viruses. And just to give you an example, the required 100,000-fold magnification to see these little creatures is equivalent to looking for the head of a pin on the OSU football field.

Although we may doubt the power of such a small adversary, we have only to be reminded that the influenza virus pandemic in 1918 claimed 20 million lives. Similarly, the smallpox virus, introduced into South America by Cortes' army, decimated both the Inca and Aztec cultures with an estimated 3.5 million victims, and changed the course of history. Although smallpox was eradicated globally in 1978, unfortunately we now face the ominous possibility that we may again confront this same enemy in the hands of bioterrorists. Even more alarming to me is that potential for using genetic engineering to artificially create infectious clones of a whole new array of viral pathogens. Thus virology, which is my chosen field, remains at the forefront of disease research.

The virus that I first viewed in Graves Hall is now recognized as the leading cause of gastroenteritis in infants and young children worldwide. An estimated 800,000 children die of rotavirus diarrhea annually, but, unfortunately, there are no human rotavirus vaccines available. Commercial rotavirus vaccines for animals also lack efficacy.

There are also no vaccines or specific treatments for the other viruses we work with, caliciviruses, which are now recognized as the leading cause of food borne disease worldwide. And this virus also could be referred to as a Buckeye virus, and has an Ohio connection, in that it was first discovered in Norwalk, Ohio, and is also referred to in the literature as Norwalk Virus. If some of you have read recent articles in the paper about the British troops in Afghanistan who came down with winter vomiting disease, this has now been recognized as a calicivirus. So this is a very important disease syndrome, with no means for prevention or control.

As Glen summarized, our research is focused on the discovery of these novel enteric viruses in animals, their adaptation to growth in cells. We've also worked to elucidate the disease mechanisms by using germ-free animals, and assess

DISTINGUISHED UNIVERSITY PROFESSOR AWARDS (contd)

Professor Saif: (contd)

the potential of these diseases for transmission from animals to humans. A long-term major goal has been and remains studies of immunity and creation of vaccines for their prevention and control.

Although I have emphasized this destructive nature of viruses, they can also be bioengineered to benefit mankind and that's also one of our focuses. This technology may someday lead to the use of bioengineered viruses to replace gene defects or to target the destruction of tumor cells and cure cancer. We are also presently creating artificial virus-like particles that cannot replicate and using these to deliver oral vaccines.

I want to certainly emphasize that, although this award is presented to me individually, research is very much a team effort. I'm extremely grateful to my former Ph.D. advisor, Dr. E. H. Bohl, who is present today, for his constant guidance and mentoring throughout my career. I also want to acknowledge the many contributions to my research of the diverse group of outstanding students, post-docs, and technicians. Currently nine countries, along with the U.S., are represented in our lab and, hopefully, a number of these students will be here today in attendance. Individually, these students have won numerous awards and honors. Certainly, one of the great strengths of OSU is attracting a highly qualified and diverse student body from all over the world.

Being part of a large comprehensive University such as OSU has also enabled me to generate international scientific collaborations, many resulting in lasting friendships and attracting new students to my laboratory. These have included a Fulbright Fellowship to Argentina to test rotavirus vaccines in herds of over 10,000 cattle -- and this is where my farm background came in very handy, when I was asked to ride on the range with the gauchos -- and also service as a scientific advisor for a U.S. AID project, promoting scientific collaboration among Egyptian and Israeli scientists. Certainly, this has been one of the most rewarding but also challenging projects I worked on.

In addition, I'm extremely grateful to the administration of OARDC and OSU, who provide my salary support, the infrastructure for my research, the technical support that has been instrumental in maintaining the continuity of my long term program, and for creating an environment that fosters research. Our germ-free animal facility is one of only a few worldwide. For those of you who do not know the Wooster Campus of OARDC, I would urge you to visit. This is truly a gem, I think, in the crown of OSU.

Finally, I'm grateful to my husband, Mo Saif, my earliest mentor and often most severe critic; our son Justin, who is present today; my late parents; and my sister and brother; for their support during my education and career.

When our son was growing up -- since we were a professional couple -- we took him along to just about every international scientific meeting we attended worldwide. I think this perhaps explains why he is currently a law student at the University of Chicago, and not pursuing a career in science.

I'd like to leave you with thoughts of the Nobel Prize physicist Marie Curie, who said, "One never notes what has been done; one can only see what remains to be done." I do not consider my most important legacy to science to be the written words reflected in my publications; rather, it is the living legacy of the outstanding students, post-docs, and visiting scholars whom it has been my privilege to mentor. Watching such students develop a passion for research and

DISTINGUISHED UNIVERSITY PROFESSOR AWARDS (contd)

Professor Saif: (contd)

blossom into independent investigators and professionals is truly a professor's greatest and lasting reward.

Again, thank you, I'm truly grateful for this honor.

Provost Ray:

Now I'd like to call on Bob Gold, dean of the College of Mathematical and Physical Sciences, to say a few words.

Dean Robert Gold:

Thank you, Ed. Since Lonnie couldn't be with us today, I thought I'd bring a little visual aid. As I'd mentioned, Lonnie is in Alaska's Wrangell Mountains on his forty-fifth field expedition. This is a mock-up of an ice core -- something to focus on.

I've had to face some difficult challenges in my time as dean, but I don't think I've ever had as hopeless a task as that of summarizing Lonnie Thompson's accomplishments in two minutes. But let me try. I'm glad that Ellen is here to accept on Lonnie's behalf and to correct my errors. Much of what I will have to say about Lonnie holds as well for Ellen. They have been partners and collaborators for over thirty years, and I would not want to try to separate their contributions. They're so close, I no longer worry whether I've sent an e-mail to thompson.3 or thompson.4. They both respond to both addresses.

Lonnie grew up in Gassaway, West Virginia, majored in geology at Marshall University, and, like Linda, came to Ohio State -- Lonnie in 1971 for Graduate School -- and never left. He earned his Ph.D. degree in 1976, spent 15 years as a research associate and research scientist at the Byrd Polar Research Center, and eventually as a faculty member in the Department of Geological Sciences.

In the early 1970s, the analysis of ice cores from polar and high latitude or cold regions was gaining recognition as a fundamental tool for the study of atmospheric and climate history. Ice is formed from the compacted snowfall, which captures air bubbles, dissolved gases, and particulate matter from the atmosphere and occasionally other debris, such as insects. Analysis of these material captured and preserved in the ice allows one to reconstruct the atmospheric conditions at the time of the snowfall.

Lonnie realized early on that there were ice archives that could fill the climate picture for the wide swath of low and warmer latitudes around the earth, the tropics and subtropics. The price to be paid, if you want ice at the subtropics, was that these archives were at very high altitudes. The experts of the day warned Lonnie that this ice would be too difficult to harvest and that the added information from this ice would not be worth the effort. Lonnie persisted and eventually showed the skeptics that not only could this ice be collected, but that it added data that is crucial to understanding the planet's climate history.

Lonnie has led expeditions to the Andes, Peru, and Bolivia, the Himalayas and the Tibetan plateau in China, and Mount Kilimanjaro in Tanzania, as well as to Alaska, Russia, and the Antarctic. He has worked for weeks at a time and, in some cases, over a month in frigid temperatures at altitude often exceeding 18,000 feet and occasionally up to 23,000 feet. He has brought over 6,000 meters of ice cores to Columbus for analysis and archiving.

DISTINGUISHED UNIVERSITY PROFESSOR AWARDS (contd)

Dean Gold: (contd)

As an adjunct to his scientific work, as Ed mentioned, Lonnie has taken on the roles as advocate for environmental stewardship, and an advisor to governments and non-governmental organizations. Lonnie's work has long been respected by his peers. He has had 11 articles appear in the *Journal of Science*. Now, some of us would kill to have one article in *Science*. Recently, formal recognition has taken a quantum leap. In the past two years, Lonnie has been identified as one of America's best in science and medicine by *Time Magazine* and *CNN*. He has been awarded the Vega Medal of the Swedish Society for Anthropology and Geography, jointly with Ellen. They have received the Commonwealth Award in Science and Innovation and the John Marshall Medal for Civic Responsibility. In September, he will receive the Heineken Prize for Environmental Sciences of the Royal Netherlands Academy of the Arts and Sciences.

Throughout all this accomplishment, Lonnie and Ellen have remained delightful colleagues, with the same good humor, humility, and honesty that I imagine they brought with them from West Virginia over thirty years ago.

I am pleased to yield to Ellen.

Professor Ellen Mosley-Thompson:

I'm not Lonnie Thompson, but I'll do the best that I can to encapsulate what I think Lonnie would have said had he been here. But since he's not here, so that you can see Lonnie Thompson, I've put together a composite of some photographs. I think the one that encapsulates probably best the effort that it takes to collect these cores is that top photograph, where Lonnie and his team are sitting in a snow cave that they've made that serves as their kitchen. They remained here at over 21,000 feet for over a month, collecting cores.

Oftentimes people will analogize that we're like mountaineers or climbers. We're not mountaineers and we're not technical climbers, because those people spend great effort to go to the highest peaks. They watch the sunset, maybe spend the night, maybe not, and trek down. Our team goes and sits for weeks or for months at a time.

We have two people here in the audience – Mary Davis and Keith Henderson, both will be getting their Ph.D. degrees this year – who have both been on multiple projects with Lonnie and have coauthored on science papers with us. So, I'd like to reflect just for a moment on what it is I think – and maybe Lonnie wouldn't say this, but I can say it because I'm not Lonnie – the things are that have contributed to the success, not only of Lonnie, but of our research team here at Ohio State.

It is often said that success is 99% perspiration and 1% inspiration, and I think that what the message really is telling us is that success requires hard work. All of the sites on the photographs – this is Lonnie's field team in 1983; the first ice core to be recovered above 18,000 feet was in 1983 by the OSU team – we were told we couldn't do it. We spent five years orchestrating this, getting the funding scraped together, building the first solar powered drill, and drilling two cores to bedrock on the Quelccaya ice cap in the Andes of Peru.

So those that are familiar with the ice core research group know that our ice core group epitomizes hard work. However, Lonnie's accomplishments are really attributable to many things, not just his hard work and his vision. Lonnie is quite visionary and, in fact, as Keith and Mary will attest, we have to keep his feet planted in reality oftentimes, because he does generate some strange visions.

DISTINGUISHED UNIVERSITY PROFESSOR AWARDS (contd)

Professor Mosley-Thompson: (contd)

There are other elements that have contributed to the success, and the first is the dedicated members of our ice core research group here at Ohio State -- our scientists and students. Right now our group numbers fifteen people, which includes graduate students.

The other thing is the quality education that both Lonnie and I gained here at Ohio State. We both came here from Marshall University and I can remember driving into Columbus. When I came to Columbus there was one tall building. Now everybody knows what building that was, right? The Lincoln LeVeque Tower. My father came to visit from West Virginia, and he said he could never get lost in Columbus because he could always see that building. And every time he came to Columbus, he got lost. He didn't realize you could see that building from 360 degrees. Lonnie and I have really grown with Columbus. But it's the quality education that we got here at Ohio State, both master's and Ph.D. degrees for both of us. Our faculty mentors, some of who are no longer with us, some of who are.

I'd like to also thank Ohio State for the very critical support that Lonnie and I, and our team have been given, not only from the very beginning but throughout the course of our almost thirty years here at Ohio State. We were very fortunate to spend our first fifteen years post-Ph.D. at the Byrd Polar Research Center. I think that the Byrd Center is likely one of the University's oldest centers; it's certainly one of its most continuously successful centers. It's an interdisciplinary center where these disciplinary boundaries become transparent as we work collectively to address these global scale problems. The one that we address most is very topical now, and that's global climate change.

In the early years Ohio State invested in us as graduate students. They built us a first-class 100 clean room lab; they built us a cold room facility. All of that was in a little corner of Mendenhall Lab. Subsequently, they built for us on West Campus, a state-of-the-art clean room and an ice core storage facility that holds over 6,000 meters of core. It's packed to the gills. Within a week, Lonnie will be returning from Bona-Churchill in Alaska -- in the St. Elias Wrangell Mountains -- where he has successfully recovered 600-meters of core that will be coming back.

I'd also like to highlight that we depend upon an international team; we have a group of people that we have worked with for many years. Lonnie is not here today because we've just completed, two days ago, drilling to bedrock on the Bona-Churchill col, 460-meters to bedrock with a drill that was designed, machined, and totally built here at Ohio State. But our field team is international. On the team we have 10 people -- scientists and engineers, seven men and three women -- one of whom is Mary Davis, who came home early in midseason, by plan, so that she can work on her dissertation; two are students, seven are Ph.D.s; two are Russian, one is from Taiwan, one is a Frenchman post-doc, and one is Australian, with six Americans.

Then finally Lonnie's success -- there is always an element of luck or serendipity -- has been sprinkled at times with many serendipitous moments, these things that happen just at the right time, a door that opens for inexplicable reasons. But when those doors open you have to be prepared and I think preparedness is a key to success. We, our team, Lonnie and I, our group -- work constantly to be prepared, but Ohio State has contributed significantly to our ability to always be prepared to take advantage of that next opportunity.

DISTINGUISHED UNIVERSITY PROFESSOR AWARDS (contd)

Professor Mosley-Thompson: (contd)

These comments have focused mainly on research and yet this is the Distinguished University Professor Award and Lonnie's philosophy, and I share that, is that you can't separate research and teaching – they are inextricably linked. Early engagement and research stimulate students to ask questions and to seek answers.

Horace Mann said, "The teacher who is attempting to teach without inspiring the pupil with the desire to learn is hammering on cold iron." And another scholar noted, "The highest function of the teacher consists not in imparting knowledge as in stimulating the pupil in its love and its pursuit." This is what we attempt to do with our research. We like to challenge the students to ask questions, and then set upon a course to answer those questions, and in so doing, they grow and ultimately contribute, just as Linda's students have, to a better world for not only us, but for the generations to come.

So on behalf of Lonnie, I'm happy to receive his award and I know that he is tremendously honored. Thank you very much.

Provost Ray:

Mr. Chairman, we also have a brief video that we'd like to share with you, and then if the Board has any questions or comments we'd be happy to hear from you.

[Video Presentation]

Mr. Patterson:

Thank you very much. Are there any questions? If not, thank you very much for being a part of our meeting today.

--0--

FAREWELL TO PRESIDENT KIRWAN

Mr. Patterson:

The final item on our agenda is somewhat bittersweet. It is the Board's formal goodbye to President Kirwan.

In his report this morning, the president highlighted many of the University's accomplishments in implementing the Academic Plan, and that was an impressive list. We know, of course, that Brit's leadership was instrumental in these accomplishments, as was his leadership in developing the Academic Plan. When Brit arrived, we had a strong desire to become one of the nation's top public universities. We did not have in place a road map to reach that goal. He supplied that road map and the needed momentum to take the first, critical steps for which we will always be grateful.

On a more personal note, it has been a great pleasure for those of us on the Board to work with Brit. His genuineness is particularly impressive. Whether he is talking to you as an individual or as one member of a group, you have his total attention, and I'm sure all of you can attest to that. That is not always easy for someone on his busy schedule, or someone who is responsible for such a complex institution. Nonetheless, Brit goes from meeting to meeting and topic to topic, never losing a beat – and always devoting himself totally to the person and

FAREWELL TO PRESIDENT KIRWAN (contd)

Mr. Patterson: (contd)

issue at hand. He cuts immediately to the core and asks the right questions. He presents issues in an easily understandable way, and he focuses on the item of immediate concern while maintaining his vision of the broader picture.

Combined with a pleasing personality and ceaseless energy, Brit has made monumental contributions to Ohio State and to Central Ohio. The same is true for Patty, Brit's full-time partner and a unique asset in her own right.

While a part of the Search Committee, we were meeting with an individual in Washington, Peter McGrath, president of the National Association of State Universities and Land-Grant Colleges, and one of our people on the Search Committee raised a question, "Are there any of the great presidents of land grant universities today like it seems like there were in the past?" And, Peter McGrath, who works with all of them, responded, "Yes, there are. There are just a few, but you have one at Ohio State in Brit Kirwan."

Brit, we have given considerable thought to how we might best honor your tenure at Ohio State. Among your areas of special interest – I would have to say passion – is your total commitment to diversity. From the moment you stepped onto this campus, you set a stake in the ground around this core principle. During your tenure, we have made great strides in becoming more diverse and more welcoming. While we have a long way yet to go, you should feel good about the progress we have made under your strong leadership.

One example of that progress is the creation of an Institute for the Study of Race and Ethnicity in the Americas. The Institute offers a meaningful opportunity for discovery and scholarship, teaching and service on many topics of major public interest and concern. Given your role in bringing the Institute to where it is today, we have decided to name it in your honor. It will become, "The William E. Kirwan Institute for the Study of Race and Ethnicity in the Americas."

NAMING OF INSTITUTE

Resolution No. 2002-154

Synopsis: Approval of the naming of the proposed Institute for the Study of Race and Ethnicity in the Americas is recommended.

WHEREAS the vision of the new Institute for the Study of Race and Ethnicity in the Americas represents a unique opportunity for the University to stimulate international research in the interdisciplinary field of race and ethnicity; and

WHEREAS the Institute will encourage top-notch scholarship in this important area and advance the University's mission of outreach on a local, national and global scale and greatly enhance our effort to recruit and retain minority faculty members, an important priority of the University's Diversity Action Plan; and

WHEREAS President William E. "Brit" Kirwan, long known as a principled and staunch proponent of diversity, proposed and developed the University's Diversity Action Plan as one of his key initiatives and a core value of the Academic Plan; and

WHEREAS in acknowledging his visionary leadership in promoting the goals and values of diversity and academic excellence, this Board wishes to recognize and honor Brit Kirwan, the university's 12th President, by naming the new Institute for the Study of Race and Ethnicity in the Americas in his honor:

NAMING OF INSTITUTE (contd)

NOW THEREFORE

BE IT RESOLVED, That the name, "The William E. Kirwan Institute for the Study of Race and Ethnicity in the Americas" is hereby approved by this Board.

Upon motion of Mr. Sofia, seconded by Ms. Longaberger, the Board of Trustees adopted the foregoing resolution by unanimous roll call vote, cast by Messrs. Patterson, Sofia, Slane, McFerson, Borrer, and Judge Duncan, Mses. Longaberger, Hendricks, and Davidson.

FAREWELL TO PRESIDENT KIRWAN (contd)

Mr. Patterson: (contd)

I'm going to turn the floor over to Brit.

Professor Kirwan:

Thank you very much. You informed me of this last night at a wonderful dinner the Trustees hosted for me and Patty. I dissolved into a pool of tears. I promised myself I would try to maintain more composure today.

It's impossible for me to convey the feelings I have at this moment. To have my name associated with something that will endure at Ohio State is extraordinarily meaningful to me, and more than I could have ever dreamed would happen. But to have my name associated with this Institute and with the cause that has been such an important part of my life, touches me in a way that nothing else in my professional life ever has. I want to thank the members of the Board of Trustees for giving me the greatest honor in my life, and for ensuring that something I very much want to happen will happen, that I will always be a part of this University. Thank you.

--0--

Thereupon the Board adjourned to meet Friday, July 12, 2002, at The Ohio State University Shisler Center on the OARDC Campus, Wooster, Ohio.

Attest:

William J. Napier
Secretary

James F. Patterson
Chairman



Academic Plan *First Year Report*

Dear Friend of Ohio State:

Eighteen months ago the Board of Trustees approved our Academic Plan, a document that defines six strategies and 14 initiatives that we deem necessary to become a truly great teaching and research university. This report highlights our progress thus far.

It is important to reiterate why we are pursuing such an ambitious goal. Top-tier universities are essential in today's knowledge economy to ensure economic growth and social progress for the people and regions that they serve. Ohio lacks such a top-tier institution, and we believe that The Ohio State University is poised to fill that role.

It is also important to remember that we have begun to implement this plan during a period of severe fiscal constraint brought about by reductions in state funding. While these constraints greatly impeded our progress, we have still made encouraging strides in our march toward academic excellence. That so much was accomplished during this difficult period is a tribute to the talent and hard work of the women and men on our faculty and staff.

While this report covers progress on all Plan strategies and initiatives, it highlights four priorities that we identified last year in recognition of our resource limitations and the resulting need to focus on relatively few items. These priorities were chosen based upon their broadly beneficial effects, the wide contributions they would make across the university and our ability to fund them – whether by reallocating existing resources, improving efficiency or raising external revenues. These initiatives will enable the university to:

- Retain and attract outstanding faculty and staff by bringing salaries up to the level of our benchmark peers;
- Strengthen significantly the quality of the academic experience for undergraduates;
- Establish Ohio State as a leader in biomedical research; and
- Create a state and national resource for understanding and resolving the issues of race and ethnicity that continue to divide us as a nation.

Shortly, my tenure at Ohio State will come to an end. It has been an extremely rewarding period in my life. I leave with a strong sense of optimism that the transformational initiatives under way at the University will enable it to reach its potential for greatness and that this greatness will lead to a brighter economic future and higher quality of life for all Ohioans.

Sincerely yours,

W. E. Kirwan
President

Academic Highlights	2
Areas of Current Focus	3
Overall Academic Plan Progress	6
The Academic Scorecard	12

Academic Highlights

- Profile of incoming freshman class has improved dramatically over six years:
 - Average ACT score has risen from 22.8 to 25.2
 - Percentage of entrants ranking in top 10 percent of high school class has risen from 21 to 32
 - One entrant in five is a minority.
- Freshman retention has risen from 77.7 percent in 1995 to 86 percent last fall.
- Research grants have increased by 34 percent (to \$329M) over the past two years.
- Ohio State ranks among *U.S. News & World Report's* Top 25 Public Universities in America and is number one in Ohio.
- From 1994 to 2002, Ohio State doubled its number of National Academy members from eight to 16. Currently, there are five members of the National Academy of Sciences, eight members of the National Academy of Engineering and three members of the Institute of Medicine.
- This year, there are a record-breaking 366 scholar-athletes, up from 263 just six years ago. Almost 40 percent of all student athletes have a GPA of 3.0 or higher.
- U.S. News ranks many graduate/professional programs tops in the nation.
- Ohio State ranks 20th in the nation in the number of national merit scholars, ahead of Vanderbilt, Duke and UCLA.
- The Council for Advancement and Support of Education ranks Ohio State 10th in fund raising among nation's public universities.
- Students have been recipients of such prestigious recognition as: British Marshall Scholars, College Bowl, Fulbright Fellows, Goldwater Scholars, Mellon Fellowships, NSF Graduate Fellowships, Truman Scholars and Finalists and Udall Scholars.
- The successful Affirm Thy Friendship campaign created 79 new endowed chairs and added more than \$105 million to the university's scholarship fund.

Areas of Current Focus

To attract and retain a top-flight faculty supported by a first-class staff necessitates compensation levels that compete favorably with those at peer institutions. Due to inadequate state support, our average salaries have fallen behind our benchmark peers, and today our faculty salaries rank 8th out of 10 peer institutions while staff salaries are below market overall and in some cases significantly so. One year ago, the President announced that correcting this inequity was our highest priority and that we would increase compensation to benchmark mean levels over the next three or four years. The first payment on that promise will be made July 1, 2002, when average compensation will rise by approximately 4.5 percent, 1 percent above the estimated increase in our external market. We have also included Graduate Associates in our benchmarking and multi-year compensation initiative while also increasing their minimum stipend and beginning to phase in a health care subsidy.

Given that over the past year state support has eroded further, it was necessary to generate much of the funding for this competitive, merit-based plan internally. We did so through a combination of increased non-state revenues and budget reallocations. Specifically, we increased tuition, private fund raising and grants; reduced centrally funded initiatives by 10 percent; asked academic support units to re-program up to seven percent of next year's budget; and asked our colleges to re-program up to five percent of next year's budget. As a result, approximately 600 positions are being eliminated, approximately 150 of which involve layoffs.

Ohio State has made great progress in attracting better-prepared students and enhancing their experience once they arrive. We now seek to shift our emphasis from retention to more advanced academic achievement and accelerated graduation timetables. To help sustain this progress, the Offices of Academic Affairs and Student Affairs have strengthened existing initiatives and created new initiatives. Examples include:

- Smaller classes, more openings in high-demand courses and curricular enhancements that respond to student needs, e.g., a new minor in Business and a proposed general Health Sciences major. Under review are ways to better integrate the General Education Curriculum into overall student programs and to more effectively integrate courses within the Colleges of Arts and Sciences.
- A new First Year Experience program that offers small seminar courses and other programs to ease the transition of first-year freshmen and transfer students into the University community.
- More and better academic and career advising for students.
- More and better classroom teaching development programs for faculty and graduate associates.

(continued)

Areas of Current Focus, cont'd

- More living-learning and other such special academic interest-based activities. Today, there are 41 living-learning communities of which nine are Scholar programs. Four in five incoming freshmen participate in such programs. (Living-learning Programs allow students who share academic and other interests to live together and participate in service learning, workshops and other enrichment activities.)
- New student housing for upper division undergraduate, graduate and professional students.
- Increased opportunities for undergraduates to incorporate research experiences into their learning.
- Recommendations to enhance the contribution of regional campuses to the mission of the University by better integrating them into the University and enhancing their role as a portal to the Columbus campus.

These and other enhancements were made possible through a combination of earmarked tuition revenues (with the impact for economically disadvantaged students softened and all students getting more for their money), improved management efficiencies and reorganizations and greater accountability.

MAKE OHIO STATE A LEADING BIOMEDICAL RESEARCH

Biomedical research is growing in importance as a national priority with technological advancements and successes brought about by the sequencing of the human genome. Ohio State has made a major commitment to become a leading player in this national arena, a commitment that is facilitated by the University's existing strengths. These strengths include interdisciplinary programs; broad research interests that range from cancer and heart disease to agriculture, biological sciences and pharmacy; and facilities such as the world's only 8 tesla MRI human magnet. A Biomedical Research Plan was developed to facilitate and leverage discovery across different types of research areas. That plan links researchers in seven different areas: Mechanisms of Health and Disease, Biomedical Informatics, Technology, Risk Factors, Assessment, Intervention and Health Outcomes. The goals of the plan are to create synergies across disciplines, link basic science researchers with clinicians and apply new technology and information to medical problems.

Groups of faculty, clustered in the seven focused areas of expertise, have been preparing inventories of existing strengths, identifying key assets and opportunities and recommending strategies for progress and collaboration. In addition to tapping into the vast expertise of current faculty, several new faculty members are playing key roles in the development of the Biomedical Research Plan, including: Joel Saltz, Medicine, who was recruited from Johns Hopkins and is leading the Biomedical Informatics component; Wolfgang Sadee, Pharmacology, who was recruited from the University of California-San Francisco and is playing a critical role in the area of Disease Intervention; and Avner Friedman, Mathematics, who was recruited from the University of Minnesota and will link his current efforts in mathematical

(continued)

biosciences, where he is working with the National Science Foundation, with Biomedical Informatics.

To facilitate the expansion of biomedical research, the University is planning to construct a state-of-the-art Biomedical Research Tower. This building is projected to open by late 2006 and will nearly double the assignable square footage devoted to biomedical research. It will be funded by the University Medical Center through the sale of capital bonds, repaid from private fund raising and increased grant awards, and by investments from the President's Strategic Investment Fund. The initiative is consistent with the high level of growth in the NIH research budget and could perhaps receive funds from the State of Ohio's tobacco settlement fund and the Governor's Third Frontier Project. Apart from its major contributions to medicine and health, the biomedical research initiative will become the focus of new faculty hires, thus creating intellectual capital, stimulating the commercialization of discovery and benefiting the Ohio economy. In addition, the Biomedical Research Plan and Tower will contribute substantially to all six Academic Plan strategies.

ORGANIZATION INSTITUTE FOR THE STUDY OF RACE AND ETHNICITY IN THE AMERICAS

Many consider race to be our nation's greatest domestic problem, a pivotal issue that in turn affects many other societal challenges such as housing, public health, education, labor supply and social justice. Given that universities exist to create knowledge and to prepare students for the world that awaits them, an institute to study race – and the related subject of ethnicity – provides a meaningful opportunity for discovery and scholarship, teaching and service. It will also contribute to intellectual life on campus and foster a University environment that will attract and retain faculty and students of color.

Founded by the Colleges of Humanities, Social and Behavioral Sciences and Law, the Institute for the Study of Race and Ethnicity in the Americas offers several unique features. These include its focus on ethnicity as well as race, its emphasis on the Americas and the fact that it begins with more than \$1 million in annual institutional investment – funds that were set aside prior to the budget cuts and which are expected to stimulate considerable grant activity. The presence of this initiative on campus will not only prepare students for a more diverse life, it will provide useful information and policy guidance for the community. This spring, following a national search, the University recruited John Powell, a nationally known scholar now serving as executive director of the Institute on Race and Poverty at the University of Minnesota, as the Institute's director. He will assume this position during the upcoming academic year.

Overall Academic Plan Progress

The following information highlights major areas of progress on the Academic Plan's six strategies and 14 initiatives.

- | | |
|---|--|
| <p>1. Over the next three to five years, recruit at least 12 faculty members who have attained or have the potential to attain the highest honors in their disciplines, concentrating these appointments in areas of strategic focus.</p> | <ul style="list-style-type: none"> ☑ In July of 2001, the Ohio Board of Regents awarded Ohio State four of the state's seven new Eminent Scholar positions, providing up to \$750,000 per position in endowment support to be matched by new University fund raising. Work is under way to identify candidates for these positions and to raise the necessary funds. ☑ In winter quarter 2001, a faculty committee recommended pursuing proposals for nine distinguished faculty hires, four of whom have already accepted offers and are actively engaged in teaching and scholarship. Discussions are under way with three other eminent faculty while two declined our offers. ☑ Among the outstanding individuals recruited to play prominent roles in the success of the Academic Plan and not otherwise cited in this report are: Martha Chamallas, Robert J. Lynn Chair in Law; Ann Hamilton, Art; Chris Hammel, Physics; Winston Ho, Engineering, Center for Materials Research; Alastair Minnis, English; and Jay Zweier, Davis Heart and Lung Research Institute. |
| <p>2. Implement a faculty recruitment, retention, and development plan – including a competitive, merit-based compensation structure that is in line with peer institutions.</p> | <ul style="list-style-type: none"> ☑ The “competitive, merit-based compensation structure that is in line with peer institutions” is discussed above. That plan was developed by a Competitive Compensation Oversight Group appointed by the President to advise the Provost and Senior Vice President for Business and Finance. All faculty and staff are eligible for the resulting increases and merit is the primary determinant of specific levels of increase. In addition, Colleges/Units are encouraged to make additional one-time cash payments to a limited number of faculty and staff to reinforce outstanding performance, retain individuals whose salaries are behind market or aid the lowest paid individuals to help offset fee increases. ☑ The Offices of Academic Affairs and Research joined with a wide variety of Colleges in funding two dozen successful counteroffers to retain valuable Ohio State faculty. |

 THE 13 SELECTIVE INVESTMENT PROGRAMS THAT DEFINE OHIO STATE AS THE NATION'S LEADING PUBLIC STATE GRANT UNIVERSITY

- | | |
|--|--|
| <p>3. Continue the Strategic Investment approach by competitively funding initiatives that build programmatic strength and open new fields. Build on existing capabilities and capture opportunities specific to Ohio State and to Ohio. Maintain ongoing multidisciplinary initiatives where appropriate and develop new initiatives that draw on University-wide strengths to attack major problems of the next quarter century. Create multidisciplinary centers that can attract additional faculty in key areas, helping reduce student-faculty ratios in high demand fields.</p> | <ul style="list-style-type: none"> ☑ The Office of Academic Affairs continued to support the 13 Selective Investment programs, Academic Enrichment commitments and other targeted central initiatives, acknowledging our desire to build excellence despite budget difficulties. We also began to realign base budgets consistent with each college's financial performance and needs of the Academic Plan, completing 16 percent of the re-basing process during FY02 and anticipating continued progress in FY03. In all, almost \$5.2 million in continuing funds were distributed to colleges for targeted purposes this year. The extent to which funds have been used for focused purposes is reflected in the fact that five of the 18 colleges received 73 percent of strategic investment funding. ☑ The Office of Research made significant multi-year commitments to a number of large-scale initiatives that show great potential to enhance the level and quality of research activities at Ohio State. Major commitments have been made to the Bioinformatics and Drug Delivery initiatives in the College of Medicine and Public Health and to the Math-Biosciences initiative in the College of Mathematical and Physical Sciences. Another significant commitment is marshalling a University-wide research response to counter terrorist activities and enhanced homeland security. ☑ Two major interdisciplinary initiatives – the University Medical Center's Biomedical Research Plan and the Institute for the Study of Race and Ethnicity in the Americas – are discussed above. |
| <p>4. Significantly increase space dedicated to funded research beyond what is currently planned. Include a multidisciplinary building devoted to high quality research space as well as to office and meeting space.</p> | <ul style="list-style-type: none"> ☑ As already noted, the new Biomedical Research Tower will nearly double the assignable square footage devoted to biomedical research in the Medical Center. Plans call for a 422,000 square-foot building with 10 stories and state-of-the-art facilities, including an animal-imaging center. The \$120 million facility will be financed largely with bonds, repaid with grant growth from increased faculty productivity. ☑ The Office of Research has developed a plan to convert a renovated Smith Laboratory to a multidisciplinary research facility that could accommodate faculty from a variety of colleges focused on a central research theme. ☑ In partnership with the Office of Facilities Planning and Development, the Office of Research has commissioned a benchmark analysis of the campus' long-term research space needs. ☑ Significant private funding contributed to many new research facilities, including the Davis Heart and Lung Research Institute, Ross Heart Hospital, Parker Food Science Building and Wildemuth Optometric Research Center as well as research facilities in Veterinary Medicine, Neuroscience and wetlands. |

(continued)

Overall Academic Plan Progress cont'd

EXPAND THE QUALITY OF THE TEACHING AND LEARNING ENVIRONMENT

- | | |
|--|---|
| <p>5. Transform the library into a 21st century Information Age center within the next five to 10 years.</p> | <p>☑ An architectural feasibility study to identify programmatic needs, architectural options and costs to renovate the Main Library has been completed, and planning continues on an option that will cost \$98 million – roughly the mid-point of four options. The project is expected to be financed with 70 percent state funds and 30 percent from private fund raising. A detailed fund-raising plan is now being developed by the Director of Libraries in consultation with the Office of Development.</p> |
| <p>6. Upgrade the quality of our classroom pool space and enhance the appearance of the campus facilities and grounds.</p> | <p>☑ Several projects to renovate large lecture halls with state funding are in the planning stages while the renovation of second-floor classrooms in Denney Hall have already been completed. In addition, many classroom projects are included in large capital projects now under way, including a new physics building, renovation of Hagerty Hall as the location of the new World Culture and Media Center, renovations for Page Hall as the home to the John Glenn Institute for Public Service and Public Policy and the construction of the signature facility for the Knowlton School of Architecture. These facilities will be flexible and appropriate in size and design for their specific use and will include state-of-the-art equipment as well as gathering spaces that encourage out-of-the-classroom learning experiences among students.</p> <p>☑ Construction began in February for the first new student housing since the late 1960s, a facility at Neil and 10th that will house about 500 graduate and professional students as well as honors/scholars undergraduates.</p> <p>☑ Ground will be broken in November 2002 for the first phase of a \$140 million, 634,000 square-foot recreation and physical activity center. This Larkins Hall renovation is a joint project of Student Affairs, the School of Physical Activity and Educational Services and the Department of Athletics.</p> <p>☑ Campus Partners began demolition this spring along North High Street to make way for construction of a University Gateway Center. The Center will be a dynamic blend of entertainment, retail, office space, rental housing and parking that is likely to cost more than \$100 million. It will better serve Ohio State students and other area residents and will become a catalyst for renewal of the entire High Street corridor.</p> |
| <p>7. Provide faculty, staff, and students with the latest technology tools for leadership in teaching, research, and career development within the next five years.</p> | <p>☑ A distance-education committee recently recommended ways for Ohio State to proceed more strategically and effectively with distributed learning and distance-education initiatives. Susan Metros, a nationally recognized leader in this field, was hired as deputy CIO for Educational Technology and Distributed Learning to provide the needed vision, leadership and expertise.</p> |

- ☑ To improve the technology infrastructure for teaching and learning, 13 new central classrooms were technology-enabled for a total of 76; 13 existing technology-enabled central classrooms were upgraded; and 228 computers were upgraded in student labs. A new classroom support web site was developed to provide faculty with access to comprehensive information on each room's technology resources.
- ☑ A Pew Foundation grant will support the redesign of Statistics 135, a chronically-closed GEC course that enrolls 3,250 students annually. The methodology developed potentially can help redesign other large courses.

ENHANCE AND RE-STRUCTURE THE STUDENT BODY

- | | |
|--|--|
| <p>8. Within the next three years, make admission to Ohio State selective throughout the year for new freshmen and for all transfer students.</p> | <ul style="list-style-type: none"> ☑ Thanks to competitive admissions in the fall quarter, the University continues to recruit an increasingly better-prepared freshman class. This is already leading to increased retention rates, with positive implications for the budget and for improved graduation rates. Extending competitive admissions to winter and spring quarters is the next step that needs to be taken so that our entire student body enters the University well prepared. |
| <p>9. Create a rich educational environment for undergraduates. Increase course accessibility, reduce class sizes, and establish at least 10 Scholars Programs within five years – expanding opportunities for students to live with those who share common interests and enhancing students' academic success and sense of community. Provide academic programming, advising, and career counseling within these communities.</p> | <ul style="list-style-type: none"> ☑ In addition to our current focus to strengthen the undergraduate experience (described above), we have completed the transition to direct enrollment, developed a computerized course monitoring program and created a program to prepare students for post-baccalaureate fellowships. ☑ Today, we have nine scholars programs. ☑ Student Affairs has developed an array of late-night alternative programming, taken measures to enhance safety in the East-of-High area and conducted educational programs to discourage dangerous behavior. In addition, the Jesse Owens recreation facility has been enhanced. ☑ A new Multicultural Center opened in 2001 to promote intellectual and cultural enrichment, programs, services and facilities for students, faculty, staff and community. |
| <p>10. Provide ample need-based and merit-based aid for undergraduates and a competitive financial aid and fellowship support package for graduate and professional students to improve Ohio State's graduate and professional matriculation rate.</p> | <ul style="list-style-type: none"> ☑ The University has maintained its tradition of softening the impact of tuition increases for needy students. Over the past two academic years, approximately 20 percent of such new fee revenue was earmarked for additional undergraduate student financial aid percent. As a result, Ohio State provided more need-based aid than other Ohio public colleges and universities. ☑ Graduate student stipends were increased beginning in August 2001. And as noted above, GAs are now included in benchmarking and the |

(continued)

Overall Academic Plan Progress cont'd

competitive compensation initiative. In addition, the University is phasing in the subsidization of health care insurance costs for graduate students.

- ☑ The Research Commission Report advocated increasing the number and value of fellowships to recruit outstanding graduate students to Ohio State and for funds to support interdisciplinary programs. The G-QUE recommendations included various ways to increase support for graduate students. The current financial climate is limiting our ability to implement these recommendations.



11. Hire at least five to ten women and five to 10 minority faculty at a senior level each year for five years through the Faculty Hiring Assistance Program (FHAP) and other initiatives.

- ☑ Sixteen women and five minorities, one of whom was female, were recruited into senior-level faculty positions and arrived on campus for the 2001-2002 academic year. Two of these individuals received some funding through the Faculty Hiring Assistance Program or FHAP.
- ☑ More broadly, we continue to progress in meeting the goals of the Diversity Action Plan. The President and Provost have repeatedly articulated the importance of our diversity initiative. Accountability measures are in place. Each college was required to develop its own diversity plan and to report annually on its progress, which is reviewed by the Diversity Council.
- ☑ The President's and Provost's Diversity Lecture series has brought 12 well-known diversity scholars to campus for stimulating discussions of diversity issues.
- ☑ Critical to future success will be effective retention strategies since we have done better in hiring women and minorities than in retaining them.

12. Recruit, support and retain to graduation larger numbers of academically able minority students.

- ☑ Admission data show that we have continued to increase the racial and ethnic diversity and enhance the overall academic preparation of our entering freshman class last fall. Approximately one freshman in five from that entering class was a member of a minority group.
- ☑ The Office of Minority Affairs instituted a program focused on the retention of African-American male students.
- ☑ The Office of Student Affairs has a very active commitment to diversity programming, encompassing hundreds of events, activities and organizations designed to support minority students, educate the campus community and create a welcoming environment for all students. Students of color are well represented in such University-wide activities as Welcome Week, Homecoming and student government as well as in activities targeted to minorities. A 2001 Campus Climate for Diversity study provides valuable data for developing programs and services that respond to student diversity issues.

13. Become the catalyst for the development of Ohio's technology-based economy. Increase collaborations with the private sector to enhance research, successfully transfer University technology and provide experiential learning and career opportunities for students.

- ☑ Scitech, the University-affiliated research and technology campus, completed Science Village Phase 1, including the Ohio MicroMD Laboratory. This multi-user, academic and industrial BioMems R&D Center will help bring Ohio State and Central Ohio into worldwide prominence in utilizing nanotechnology to improve health care. Phase 1 also includes space for Honda R&D Americas, iMEDD, the Columbus Technology Leadership Council and Battelle Technology Fund.
- ☑ The Business Technology Center (BTC) incubator now houses 16 companies. It started and/or invested in seven companies and developed space for Leadscope, a bioinformatics company.
- ☑ The pieces are coming together for an effective pipeline that connects the University to the commercial world. Besides Scitech and the BTC, it includes the Technology Commercialization Corporation, which helps new companies get started.
- ☑ Industry-sponsored research continues to grow, and a host of University research centers contribute to economic growth, examples being the Center for Advanced Polymer and Composite Engineering, the Center for Excellence in Manufacturing Management and the Food Industries Center. Other academic-industry partnerships help prepare students for industrial jobs. Now in its second year, the Pre-Kindergarten through 12th grade Project has created the *Learning Bridge*, a neighborhood schools initiative that includes the Columbus Public Schools, Columbus Education Association, and agency and community representatives.

14. Significantly strengthen the scope and effectiveness of our commitment to P-12 public education, with a special focus on the education of underserved children and youth. In so doing, work with the State of Ohio and selected local school districts. This initiative will be a University-wide partnership with the College of Education in the lead college role.

- ☑ Working with the Service Learning initiative and Student Affairs, the P-12 Project has created the *Community Connection*, a web-based volunteer matching and training system that will be available to the University and the community next autumn.
- ☑ It also created the *Ohio Collaborative – Research and Policy for Schools, Children, and Families*, a statewide research and policy center to coalesce higher education faculty throughout Ohio to provide research and policy support for the Ohio General Assembly, Governor's Office, Ohio Board of Regents, and the Ohio Department of Education. The *Ohio Collaborative* is already assisting the Governor's Commission on Teaching Success, the Ohio Families and Children First initiative and the Columbus Public Schools.
- ☑ In addition, the P-12 Project helped support the formation of the *University Teacher Education Council*, a structure comprised of equal numbers of education and arts and sciences faculty to strengthen the initial preparation of education professionals.

The Academic Scorecard

Strategy	Strategic Indicator	Ohio State	Benchmark Universities	OSU Change from previous reported year
Build a World Class Faculty				
	1. Academic Honors and Awards (2000)	39	78.2	7.00
	2. Market Share of Publications (1998-2000)	0.40	0.49	-0.01
	3. Market Share of Citations (1998-2000)	0.51	0.81	-0.01
	4. Market Share of Federal Research Dollars (2000)	0.76	1.46	-0.09
	5. Average Faculty Compensation (FY2001)	\$73,929	\$76,406	\$503
			Marginal Increase in OSU/Benchmark Gap	
Define Ohio State as Leading Public Land Grant				
			Benchmark Average	
	1. US News Academic Reputation Score (2001)	3.8	4.1	NC
	2. US News Academic PhD programs among the Top 25 (2002)	6	8.6	1
	3. US News Professional programs among the Top 25 (2002)	6	6.8	-1
	4. NRC Academic PhD programs among the top 25% (1992)	9	20	NI
Enhance the Quality of the Teaching & Learning Environment				
			National Average	
	1. % of Faculty Satisfied Overall (1999*)	71.1	73.2	NI
	2. % of Students Satisfied with Instruction and Courses (2001)	59	66	1
	3. % of Students Satisfied with Campus Facilities (2001)	66	72	4
Enhance and Better Serve the Student Body				
			Benchmark Average	
	1. % of Freshmen in the Top 10% of H.S. Class (2000)	32	52	3
	2. Freshmen Retention Rate (2000)	82	90	3
	3. Six-year Graduation Rate (2000)	55	71	-1
	4. Four-year Graduation Rate (2000)	19	40.3	NC
	5. Average GMAT score for MBA students (2000)	645	653.7	-1
	6. Average LSAT range for Law students (2001)	155-161	159-164	1
			National Average	
	7. Average GRE verbal score for graduate students (2000)	548	498	3
	8. Average GRE quantitative score for graduate students (2000)	657	637	2
	9. Average GRE analytic score for graduate students (2000)	652	612	15
	10. % of Students Satisfied with Student Support Services (2001)	43	51	-4
Create a Diverse University Community				
			Benchmark Average	
	1. % of Women Faculty (2000)	31.4	28.1	1.5
	2. % of African American, Hispanic, and Native American Faculty (2000)	4.99	5.77	-0.39
	3. % of Minority Staff (2000)	18.9	14	1.2
	4. % of African-American & Hispanic Students (2000)	10	10.4	NC
	5. African-American Freshmen Retention Rate (2000)	77	83	3
	6. Hispanic Freshmen Retention Rate (2000)	78	84	1
	7. African American 6-Year Graduation Rate (2000)	42	51	5
	8. Hispanic 6-Year Graduation Rate (2000)	37	56	-5
Help Build Ohio's Future				
		OSU 2001	Benchmark Ave. 1999	
	1. Number of Invention Disclosures (OSU-2001; Bchmks-1999)	109	169	9
	2. Number of Patent Applications (OSU-2001; Bchmks-1999)	53	112	18
	2. Number of Patents Awarded (OSU-2001; Bchmks-1999)	23	39	5
	3. Number of License/Options Executed (OSU-2001; Bchmks-1999)	41	57	15
	4. Number of Start Up Companies (OSU-2001; Bchmks-1999)	7	3	7
	5. Revenue from Income Generating Licenses (OSU-2001; Bchmks-1999)	\$1.5 mil	\$7,869,425	(\$162,000)
	6. Sponsored Research Dollars for Education (1999)	\$13.1 mil	\$10.5 mil	NI
	7. Impact of P-12 Initiatives	TBD		
	8. Impact of Principal's Academy	TBD		

Prepared by Resource Management Systems and Institutional Analysis

Note: Benchmark institutions are large, comprehensive, Research I universities, many of which currently outrank Ohio State in various reputational surveys.

NC: No Change from Previous Reporting Period
 NI: No Information about Earlier Reporting Period
 * Faculty Satisfaction will be measured again in 2002.
 **Data was available for 5 of the 9 benchmarks.

For more information about The Ohio State University Academic Plan, visit www.osu.edu/academicplan

Presidential Commission on the Regional Campuses

June 2002

Commission Membership:

Bobby D. Moser, Vice President for Agricultural Administration and University Outreach, and Commission Chair

Leslie A. Beyer-Hermsen, Assistant Dean, OSU-Marion

Professor Graeme M. Boone, School of Music, College of the Arts

Thomas A. Brannon, Chair, Board of Trustees, Newark

Professor Terri D. Fisher, OSU-Mansfield (Psychology)

Robert Gold, Dean, College of Mathematical and Physical Sciences

Professor John M. Hellmann, OSU-Lima (English)

Karen L. Hendricks, Board of Trustees

James J. Mager, Associate Vice President, Enrollment Services

James F. Patterson, Chair, Board of Trustees

Professor Richard E. Petty, Chair, Department of Psychology

John O. Riedl, Dean/Director, OSU-Mansfield, Coordinating Dean, Regional Campuses

Shellie R. Shirk, Undergraduate Student, OSU-Marion

W. Randy Smith, Vice Provost, Office of Academic Affairs

Professor R. Vladimir Steffel, OSU-Marion (History)

Professor Matthew B. Stenzel, OSU-Newark (Mathematics)

Diane S. Whitbeck, Associate Vice President, Housing and Student Services

Activities

- reviewed the Academic Plan; the “working paper” prepared for the Commission’s use; the 1997 University Accreditation Report; the 1996 Regional Campus Functional Mission Statements; and other documents.
- decided to organize its work through four Subcommittees. Each gathered and analyzed relevant information for its tasks and held separate meetings.

Mission/Governance (**Karen Hendricks, Chair**, Thomas Brannon, John Hellmann, and John Riedl)

Admissions/Enrollment (**James Mager, Chair**, Terri Fisher, James Patterson, and W. Randy Smith)

Students/Student Services (**Diane Whitbeck, Chair**, Robert Gold, Vladimir Steffel, and Shellie Shirk)

Faculty/Curriculum (**Richard Petty, Chair**, Leslie Beyer-Hermsen, Graeme Boone, Matthew Stenzel, and W. Randy Smith)

- interviewed Vice Provosts for Regional Campuses at the Pennsylvania State University and the University of South Carolina.
- held site visits at each Regional Campus (November 1, 8, 2001)
- met with Dr. Garrison Walters, Vice Chancellor, Ohio Board of Regents
- met with the Presidents of three of the Co-located Technical Colleges (Central Ohio Technical College; Lima Technical College; North Central State College).
- met with the University Staff Advisory Committee.
- met, as a group, with the President of the Newark Campus, Dr. Anne Cairns Federlein, and the Regional Campus Deans/Directors, Dr. F. Dominic Dottavio – Marion; Dr. Violet I. Meek – Lima; and Dr. John O. Riedl – Mansfield.
- met, as a group, with the five Deans of the Colleges of the Arts and Sciences Deans (Karen A. Bell, Dean, College of the Arts; Robert Gold, Dean, College of Mathematical and Physical Sciences; Richard Hall, Interim Dean, College of Biological Sciences; Michael Hogan, Dean, College of Humanities; and Randall B. Ripley, Dean, College of Social and Behavioral Sciences); and with Professor Evelyn B. Freeman, Director, School of Teaching and Learning, College of Education

Presidential Commission for the Regional Campuses

Recommendations

Regional campuses – their roles and characteristics – are not well understood by most members of the total University community.

- **Clarify why we need regional campuses.**
 - Accessibility to Ohio citizens who would otherwise be unserved; an alternative to those who are place-bound or whose preparation is not yet sufficient for enrollment on the Columbus campus
 - Extend OSU's geographical presence
 - Enhance economic development in four regions of the state
 - Through outreach and engagement activities, strengthen learning opportunities within the local community

- **Need to adhere to the “one-university” model but with stronger internal “system” characteristics.**

Mission/Governance

1. Regional campuses are a part of OSU and as such share the vision purpose, core values, and future goals of the University's strategic plan.
 - **Revise the University's “vision” statement highlighting the unique role of the Regional Campuses**

2. With regard to governance, all campuses operate from a common set of bylaws for Regional Campus Boards of Trustees. More specificity is needed regarding Board authority and delegation.
 - **Revise the By-laws of the regional campuses Boards of Trustees to introduce a more structured nomination and selection process; better educate and communicate directly with local board members; seek financial synergies across regional campuses rather than only with co-located technical college**

3. Stronger internal “systems” operations need to be adopted.
 - **The Executive Vice President and Provost should review the current pattern of interactions between the Vice Provosts and the regional campuses and determine how, administratively, coordination will be improved. The result should in no way interfere with the current pattern of the dean/director having direct access to the Provost when needed.**

Admissions/Enrollment

1. The current application process does not give students a set of choices.
 - **Beginning with the class of 2003 ask students to indicate both a first choice and alternate-choice campus**
 - **In consultation with the regional campuses, Undergraduate Admissions should revise the options letter to Ohio residents denied admission to the Columbus campus.**
2. Current “campus change” policy permits students to move from a regional Campus after completing 30 credit hours and with a 2.0 GPA.
 - **With the exception of students whose high school credentials qualify them for admission to the Columbus campus, students beginning on regional campuses must complete a full year (45 credit hours) before changing to the Columbus campus.**
3. The regional campuses have open admission policies for Ohio applicants and competitive admission policies for non-residents.
 - **In the long run, if a regional campus cannot accommodate demands for academic resources, the following priorities should guide admission policies for regional campuses:**
 - open admission for Ohio residents
 - if space remains, after accommodating all interested Ohio residents, then selective admission of non-residents
4. There are very distinct groups of students at regional campuses. Most make the decision whether and when to move to Columbus on their own. They use advisers to facilitate the change not to help with the decision. The advisers seem to have consistent ways of advising students as a function of the student’s major, academic ability, and circumstances. The advisers seem always to put the student’s educational goals and personal situation at the forefront and have no vested interest in the student’s specific campus selection.
 - **The advising system should continue to work in OSU-system terms.**
 - **Efforts should be made to follow-up, in a more systematic way, with students who have moved to Columbus, to gather information on the adjustment process. That information could then be used to help future students.**
5. There is not a fully developed, consistent message in marketing/recruiting efforts relating to the regional campuses: their nature, their role in the University.

- **Marketing messages must evolve as academic, residential, and co-curricular opportunities on regional campuses and satellite locations develop. Effective with recruitment of the class of 2003: a description of the university system of campuses will become standard in all comprehensive recruitment presentations; publications and other marketing communications will refer to “all campuses” when describing the features or opportunities common to all campuses; and references to University opportunities for working, non-traditional students will increasingly cite regional campus opportunities.**
- **A sophisticated regional campus enrollment projection process must be developed and implemented as soon as possible.**

Student/Student Services

- **The University should adopt the OSU-owned and managed approach to student housing on the regional campuses. This approach may take longer and the costs will be higher, but the University has experience in such activity and is attuned to the importance of establishing appropriate academic housing needs.**
- **The University should adopt the “collaboration” model for the future development of student services. This would mean close collaboration with the Office of Student Affairs in Columbus. It is an option in alignment with the “system” approach advocated throughout this report.**

The Faculty and Curriculum

- **The University has adopted the “one university” (versus University-system) model for personnel and curricular development. For some academic units several long-term issues emerge from this approach. The University should study other institutions to see how other models might provide creative alternatives to the one-University model.**
- **There should be modest expansion of undergraduate major programs: individual campuses may focus on specific curricular needs and share that program, via distance, with others. Such expansion must occur through careful planning.**

Co-location

- **monitor issues related to co-location and their effect on regional campus planning**

(APPENDIX XLIX)

**THE OHIO STATE UNIVERSITY HOSPITALS
BYLAWS OF THE MEDICAL STAFF
Revisions - April 25, 2002**

IMPACT STATEMENT

- I. Amendments to comply with Joint Commission on Accreditation of Healthcare Organizations (JCAHO).
 - A. Define and clarify mechanisms for the supervision of resident physicians by teaching medical staff physicians, and revise limited staff responsibilities and privileges.
 - B. Restrict the use of temporary privileges to cases of patient care necessity.
 - C. Require attendance at medical staff administrative committee meeting by department chairs and representatives for two-thirds of meetings unless excused.
 - D. Offer education regarding medical staff impairment at general medical staff meetings.
- II. Eliminate the category of community affiliate staff, thereby limiting medical staff membership to OSU faculty members.
- III. Delete limited staff as members of the medical staff, making it clear they are not independent practitioners. Limited staff will continue to be credentialed as in the past.
- IV. Make clerical changes and update clinical divisions.
- V. Require a super majority vote of the Medical Staff Administrative Committee to terminate membership, non-reappoint, or permanently suspend medical staff membership.

This is intended to assure a broad consensus in these types of major determinations.

**AMENDMENTS TO THE *BYLAWS OF THE MEDICAL STAFF OF*
THE OHIO STATE UNIVERSITY HOSPITALS**

Amended Bylaws of the Medical Staff

3335-43-02 Purpose.

The purpose of the medical staff of the Ohio state university hospitals shall be:

- (A) To strive to maintain quality standards of patient care for all patients admitted to the Ohio state university hospitals, consistent with an active teaching environment, realizing that the care and treatment of the individual patient is the medical responsibility of the member of the honorary, attending, and courtesy, ~~and community-affiliate~~ medical staff to whose care the patient is admitted or transferred.

Balance unchanged.

3335-43-03 Patients.

- (A) The continuous care and treatment of individual patients is the medical responsibility of the member of the honorary, attending, and courtesy ~~and community-affiliate~~ medical staff to whose care the patient is admitted or transferred within the Ohio state university hospitals and to licensed health care professionals being granted clinical privileges under these bylaws.

Balance unchanged.

3335-43-04 Membership.

- (A) Qualifications.

(1) Unchanged.

- (2) All members of the medical staff of the Ohio state university hospitals shall, except as specifically provided in these bylaws, be members of the faculty of the Ohio state university college of medicine and public health, or in the case of dentists, of the Ohio state university college of dentistry, and shall, except for members of the limited staff, be duly licensed to practice in the state of Ohio. Members of the limited staff shall possess a valid training certificate, and or an unrestricted license from the applicable state board based on the eligibility criteria defined by that board. All members of the medical staff and limited staff shall comply with provisions of state law and the regulations of the state medical board. Only those physicians, dentists, and practitioners of psychology and podiatry who can document their education, training, experience, competence, adherence to the ethics of their profession, dedication to educational and research-goals, and ability to work with others with sufficient adequacy to assure the university hospitals board and the board of trustees of the Ohio state university that any patient treated by them at university hospitals will be given the high quality of medical care provided at university hospitals, shall be qualified for membership on the medical staff of the Ohio state university hospitals.

All members of the medical staff will comply with medical staff and the Ohio state university policies regarding employee and medical staff health and safety; in compensated care; and will comply with appropriate administrative directives and policies to avoid disrupting those operations of the Ohio state university hospitals which adversely impact overall patient care or which adversely impact the ability of the Ohio state university hospitals employees or staff to effectively and efficiently fulfill their responsibilities. All members of the medical staff will comply with policies adopted by the medical staff administrative committee, including but not limited to policies on disruptive behavior, conflict of interest, and access and communication guidelines.

**AMENDMENTS TO THE *BYLAWS OF THE MEDICAL STAFF OF
THE OHIO STATE UNIVERSITY HOSPITALS* (contd)**

Amended Bylaws of the Medical Staff (contd)

(3) through (6) Unchanged.

(B) Application for membership.

Initial application for medical staff membership for all categories of the medical staff ~~except community-affiliate staff~~ shall be made by the applicant to the chief of the clinical department on forms prescribed by the medical staff administrative committee stating the qualifications and references of the applicant and giving an account of the applicant's current licensure, relevant professional training and experience, current competence and ability to perform the clinical privileges requested. ~~All applicants for initial appointment to the community affiliate staff shall be made to the medical director.~~ All applications for appointment must specify the clinical privileges requested. Applications may be made only if the applicant meets the qualifications outlined in paragraph (A) of this rule. The application shall include written statements of the applicant to abide by the bylaws, rules and regulations of the medical staff, the university hospitals board, and the board of trustees of the Ohio state university. The application shall also contain a statement acknowledging that membership on the medical staff requires participation in the peer review process of evaluating credentials, medical staff membership and clinical privileges, and that a condition for membership requires mutual covenants between all members of the medical staff to release one another from civil liability in this review process as long as the peer review is not conducted in bad faith, with malice, or without reasonable effort to ascertain the accuracy of information being disclosed or relied upon. ~~In addition for community affiliate staff in order to optimize the clinical organization resource utilization and planning of the Ohio state university hospitals, the medical director may require that the community affiliate staff member identify categories of diagnosis, extent of anticipated patient activity, and service areas to be utilized and may prepare a statement of participation for the applicant which shall be made a part of the application for appointment.~~ A separate record shall be maintained for each applicant requesting appointment to the medical staff.

(C) Terms of appointment. Initial appointment to the medical staff shall be for a period extending to the end of the fiscal year (first of July through thirtieth of June). Reappointment to the medical staff shall be done on a regular basis for a period not to exceed twenty-four months. Initial appointment, except appointment to the honorary medical or limited medical staff categories, shall be provisional for six months regardless of the date of the appointment. During the period of the provisional appointment all applicants shall be subject to continuous review and reconsideration pursuant to these bylaws. Following the six-month period if no adverse action has been taken the appointment shall no longer be provisional.

(D) Unchanged.

(E) Procedure for appointment.

(1) The written and signed application for membership on the medical staff shall be presented to the applicable chief of the clinical department, ~~or in the case of community-affiliate staff, to the medical director.~~ The applicant shall include in the application a signed statement indicating the following:

(a) through (h) unchanged.

(2) through (3) unchanged.

**AMENDMENTS TO THE *BYLAWS OF THE MEDICAL STAFF OF
THE OHIO STATE UNIVERSITY HOSPITALS* (contd)**

Amended Bylaws of the Medical Staff (contd)

- (4) The chief of the applicable clinical department shall be responsible for investigating and verifying the character, qualifications, and professional standing of the applicant by making inquiry of the primary source of such information and shall within ~~sixty~~ thirty days of receipt of the signed application, submit a report of those findings along with a recommendation on membership and clinical privileges to the medical director of the Ohio university hospitals.
- (5) Unchanged.
- (6) Completed applications shall be acted upon as follows:
- (a) Unchanged.
- (b) By the medical staff administrative committee within ~~sixty~~ thirty days after receipt of a completed application and the report and recommendation of the credentials committee.

Balance unchanged.

- (7) The credentials committee shall review the application, evaluate and verify the supporting documentation, references, licensure, the chief of the clinical department's report and recommendation, and other relevant information. The credentials committee shall examine the character, professional competence, qualifications and ethical standing of the applicant and shall determine, through information contained in personal references and from other sources available to the credentials committee, including an appraisal from the chief of the clinical department in which clinical privileges are sought, whether the applicant has established and meets all of the necessary qualifications for the category of medical staff membership and clinical privileges requested.

The credentials committee shall, within thirty days from receipt of a complete application, make a recommendation to the medical director that the application be accepted, rejected, or modified. The medical director shall forward the recommendation of the credentials committee to the medical staff administrative committee. The credentials committee or the medical director may recommend to the medical staff administrative committee that certain applications for appointment be reviewed in executive session. The recommendation of the medical staff administrative committee regarding an appointment decision shall be made within ~~sixty~~ thirty days of receipt of the credentials committee recommendation and shall be communicated by the medical director, along with the recommendation of the medical director to the professional affairs, research and education committee of the university hospitals board, and thereafter to the university hospitals board. When the Ohio state university hospitals board has acted, the chairperson of the board shall instruct the medical director to transmit the final decision to the chief of the clinical department and applicant and, if appropriate, to the director of the applicable clinical division. The chairperson of the board shall also notify the dean of the college of medicine and public health and the executive director of the Ohio state university hospitals of the decision of the board.

- (8) Unchanged.

**AMENDMENTS TO THE *BYLAWS OF THE MEDICAL STAFF OF
THE OHIO STATE UNIVERSITY HOSPITALS (contd)***

Amended Bylaws of the Medical Staff (contd)

(F) Procedure for reappointment.

(1) through (4) unchanged.

(5) When the decision of the medical staff administrative committee results in a decision of non-reappointment or ~~adverse change in~~ reduction, suspension or revocation of clinical privileges, the medical staff administrative committee shall instruct the medical director to give written notice to the affected member of the decision, the stated reason for the decision, and the member's right to a hearing pursuant to paragraphs (A) and (B) of rule 3335-43-06 of the Administrative Code. This notification and an opportunity to exhaust the appeal process shall occur prior to an adverse decision unless the provisions outlined in paragraph (D) of rule 3335-43-05 of the Administrative Code apply. The notice by the medical director shall be sent certified return receipt mail to the affected member's last known address as determined by the Ohio state university records.

(6) and (7) unchanged.

3335-43-05 Peer review and corrective action.

(A) through (C) unchanged.

(D) Summary suspension.

(1) Notwithstanding the provisions of this rule, a member of the medical staff shall have all or any portion of his or her clinical privileges suspended or appointment terminated by the medical director or the chief of the member's clinical department whenever such action must be taken immediately in the best interest of patient care. Such summary suspension shall become effective immediately upon imposition and the medical staff member shall be subsequently notified in writing of the suspension by the medical director. Such notice shall be issued by certified return mail to the affected medical staff member's last known address as determined by university records.

(2) A medical staff member whose privileges have been summarily suspended or whose appointment has been terminated shall be entitled to a hearing and appeal of the suspension pursuant to rule 3335-43-06 of the Administrative Code. If the affected member of the medical staff does not make a written request for a hearing to the medical director within thirty-one days after receipt of the adverse decision, it shall be deemed a waiver of the right to any review by the medical staff administrative committee to which the staff member might otherwise have been entitled on the matter. If a timely, written request for a hearing is made, the procedures of rule 3335-43-06 of the Administrative Code shall apply.

(3) Unchanged.

(E) and (F) unchanged.

3335-43-06 Hearing and appeal process.

(A) through (D) unchanged.

**AMENDMENTS TO THE *BYLAWS OF THE MEDICAL STAFF OF
THE OHIO STATE UNIVERSITY HOSPITALS (contd)***

Amended *Bylaws of the Medical Staff (contd)*

- (E) Appeal process.
- (1) Unchanged.
- (2) If an appeal is not requested within fourteen thirty days, the affected medical staff member shall be deemed to have:
- (a) and (b) unchanged.
- (3) through (7) unchanged.

3335-43-07 Categories of the medical staff.

The medical staff of the Ohio state university hospitals shall be divided into ~~honorary, attending, courtesy, community affiliate and limited~~ four categories: honorary medical staff; attending medical staff; courtesy medical staff; and limited staff.

(A) Honorary medical staff.

- (1) The honorary medical staff shall be composed of those individuals who hold emeritus faculty status and who are recognized for outstanding reputation, notable scientific and professional contributions, and high professional stature. Nominations may be made to the medical director who shall present the candidate to the medical staff administrative committee for approval.

Members of the honorary medical staff shall have access to the Ohio state university hospitals and shall be given notice of all medical staff activities and meetings. However, members of the honorary medical staff shall not be required to attend staff meetings or pay medical staff dues. Members of the honorary medical staff shall enjoy all privileges and responsibilities of an attending medical staff member except members of the honorary medical staff shall not have the right to vote or hold elected office in the medical staff organization.

- (2) Honorary medical staff members who do not desire to exercise clinical privileges may notify the credentials committee in writing. The credentials committee shall have the discretion to waive portions of the customary reappointment procedures.

Members of the honorary medical staff who desire clinical privileges shall be subject to the appointment and reappointment procedures specified in these bylaws.

(B) Attending medical staff.

- (1) Qualifications: The attending medical staff shall consist of those faculty members of the colleges of medicine and public health and dentistry to whom clinical teaching responsibilities are assigned in the Ohio state university hospitals and who satisfy the requirements and qualifications for membership set forth in rule 3335-43-04 of the Administrative Code. The assignment of teaching responsibility is the prerogative of the chief of the clinical department or the chief's designee.

**AMENDMENTS TO THE *BYLAWS OF THE MEDICAL STAFF OF
THE OHIO STATE UNIVERSITY HOSPITALS (contd)***

Amended Bylaws of the Medical Staff (contd)

(2) Prerogatives:

An attending medical staff member may:

(a) Admit patients consistent with the balanced teaching and patient care responsibilities of the Ohio state university hospitals. When, in the judgment of the chief of the clinical department, a balanced teaching program is jeopardized, following consultation with the dean of the college of medicine and public health and the Ohio state university hospitals' executive director, and with the concurrence of a majority of the medical staff administrative committee, the chief of the clinical department may restrict an attending medical staff member's ability to admit patients. Imposition of such restrictions shall not entitle the attending medical staff member to a hearing or appeal pursuant to rule 3335-43-06 of the Administrative Code.

(b) through (d) unchanged.

(3) Responsibilities:

Each member of the attending medical staff shall:

(a) through (d) unchanged.

(e) Supervise members of the limited staff in the provision of patient care in accordance with accreditation standards and policies and procedures of approved clinical training programs. It is the responsibility of the attending physician to authorize each member of the limited staff to perform only those services which the limited staff member is competent to perform under supervision.

(C) Courtesy medical staff.

(1) Qualifications: The courtesy medical staff shall consist of those faculty members of the colleges of medicine and public health and dentistry who do not qualify for attending medical staff appointment.

(2) Prerogatives:

The courtesy medical staff may:

(a) Admit patients that complement the clinical teaching program. At times when inpatient beds at the Ohio state university hospitals or other resources are in short supply, patient admissions of courtesy medical staff shall be subordinate to those of attending medical staff.

(b) Unchanged.

(c) Attend meetings as a member of the medical staff and the clinical department of which he or she is a member and any medical staff or the Ohio state university hospitals education programs. The courtesy medical staff member may vote for and be eligible to hold a position on the medical staff administrative committee reserved for the representative of the courtesy

**AMENDMENTS TO THE *BYLAWS OF THE MEDICAL STAFF OF*
THE OHIO STATE UNIVERSITY HOSPITALS (contd)**

Amended Bylaws of the Medical Staff (contd)

~~medical or community-affiliate~~ staff as set forth in paragraph (D) of rule 3335-43-09 and paragraph (D) of rule 3335-43-10 of the Administrative Code. Members of the courtesy medical staff may serve on non-elected medical staff committees as provided by these bylaws.

- (3) Responsibilities: Each member of the courtesy medical staff shall be required to discharge the basic responsibilities specified in paragraph (B)(3) of this rule.

(D) Limited staff.

Limited staff are not considered full members of the medical staff, do not have delineated clinical privileges and do not have the right to vote in general medical staff elections. Except where expressly stated, members of the limited staff are bound by the terms of these bylaws, the rules and regulations of the medical staff, and the limited staff agreement.

(1) Qualifications:

- (a) The limited staff shall consist of doctors of medicine, osteopathic medicine, dentists and practitioners of podiatry or psychology who are ~~appointed~~ accepted in good standing in by a program director into a post-doctoral educational programs established and supervised by the chief of the clinical department or director of the clinical division post-doctoral graduate medical education program and appointed to the limited staff in accordance with these bylaws.
- (b) The limited staff shall maintain compliance with the requirements of state law, including regulations adopted by the Ohio state medical board, or the limited staff member's respective licensing board.
- (c) Members of the limited staff shall possess a valid training certificate or an unrestricted Ohio license from the applicable state board based on eligibility criteria defined by that state board. All members of the limited staff, except dentists, shall be required to successfully obtain an Ohio training certificate prior to beginning training within a program. Also, members of the limited staff, except dentists, shall make written application for an Ohio license no later than one year after becoming eligible for an Ohio license and must thereafter obtain and maintain licensure in Ohio during the term of the limited staff member's post doctoral post-doctoral education.

(2) Responsibilities:

Each member of the limited staff shall:

- (a) Be responsible to respond to all questions and to complete all forms as may be required by the credentials committee.
- (a)
- (b) Participate fully in the teaching programs, conferences, and seminars of the clinical department in which he or she is appointed in accordance with accreditation standards and policies and procedures of the graduate medical education committee and approved clinical training programs.

**AMENDMENTS TO THE *BYLAWS OF THE MEDICAL STAFF OF
THE OHIO STATE UNIVERSITY HOSPITALS (contd)***

Amended *Bylaws of the Medical Staff* (contd)

- ~~(b)~~
- ~~(c)~~ Not admit patients, but shall participate, under supervision, in the care of all patients assigned to the limited staff member. Participate in the care of all patients assigned to the limited staff member under the appropriate supervision of a designated member of the attending or courtesy medical staff in accordance with accreditation standards and policies and procedures of the clinical training programs. The clinical activities of the limited staff shall be determined by the program director appropriate for the level of education and training. Limited staff shall be permitted to perform only those services that they are authorized to perform by the member of the attending or courtesy medical staff based on the competence of the limited staff to perform such services. The limited staff may admit or discharge patients only when acting on behalf of the attending or courtesy medical staff. The limited staff member shall follow all rules and regulations of the service to which the limited staff member is assigned, as well as the general rules of the Ohio state university hospitals pertaining to limited staff, including, but not limited to the following requirement: the Specifically, a limited staff member shall consult with the honorary, attending, or courtesy, or community affiliate member of the medical staff responsible for the care of the patient before the limited staff member undertakes a procedure or treatment that carries a significant, risk material-risk to the patient unless the consultation would cause a delay that would jeopardize the life or health of the patient.
- ~~(e)~~
- ~~(d)~~ Serve as a member of various medical staff committees to which the limited staff member is assigned in accordance with established committee composition as described in these bylaws and/or the rules and regulations of the medical staff. The limited staff member shall not be eligible to vote or hold elected office in the medical staff organization but may vote on committees to which the limited staff member is assigned.
- ~~(d)~~
- ~~(e)~~ Be expected to make regular satisfactory professional progress including anticipated certification by the respective specialty or sub-specialty program of post-doctoral training in which the limited staff member is enrolled. Evaluation of professional growth and appropriate humanistic qualities shall be made on a regular schedule by the clinical departmental chief or division director, program director, teaching faculty or evaluation committee in accordance with accreditation standards and policies and procedures of the approved training programs. Failure to meet reasonable expectations may result in sanctions including probation, lack of reappointment, suspension or termination.
- ~~(e)~~
- ~~(f)~~ Appeal by a member of the limited staff of probation, lack of reappointment, suspension or termination for failure to meet expectations for professional growth or failure to display appropriate humanistic qualities or failure to successfully complete any other competency as required by the accreditation standards of an approved training program will be conducted and limited in accordance with written guidelines established by the respective department or division training program and approved by the medical director and institutional post-M.D. the Ohio state university hospitals graduate medical education committee as delineated in the limited staff agreement.

**AMENDMENTS TO THE BYLAWS OF THE MEDICAL STAFF OF
THE OHIO STATE UNIVERSITY HOSPITALS (contd)**

Amended Bylaws of the Medical Staff (contd)

Alleged misconduct by a member of the limited staff, for reasons other than failure to meet expectations of professional growth as outlined above, shall be handled in accordance with rules 3335-43-05 and 3335-43-06 of the Administrative Code.

(3) Failure to meet reasonable expectations.

Failure to meet reasonable expectations may result in sanctions including but not limited to probation, lack of reappointment, suspension or termination. Termination of limited staff member status shall result in automatic termination of the limited staff member's residency or fellowship appointment pursuant to these bylaws.

(4) Temporary appointments.

(a) Limited staff members who are Ohio state university faculty may be granted an early commencement or an extension of appointment upon the recommendation of the chief of the clinical department, with prior concurrence of the medical director, when it is necessary for the limited staff member to begin his or her training program prior to or extend his or her training program beyond a regular appointment period. These appointments shall not exceed sixty days.

(b) Temporary appointments may be granted upon the recommendation of the chief of the clinical department, with prior concurrence of the medical director, for limited staff members who are not Ohio state university faculty but who, pursuant to education affiliate agreements approved by the university, need to satisfy approved graduate medical education clinical rotation requirements. These appointments shall not exceed a total of one hundred twenty days in any given post-graduate year. In such cases, the mandatory requirement for a faculty appointment may be waived. All other requirements for limited staff member appointment must be satisfied.

(5) Supervision.

Limited staff members shall be under the supervision of an attending or courtesy medical staff member. Limited staff members shall have no privileges as such but shall be able to care for patients under the supervision and responsibility of their attending or courtesy medical staff member. The care they extend will be governed by these bylaws and the general rules and regulations of each clinical department. The practice of care shall be limited by the scope of privileges of their attending or courtesy medical staff member. Any concerns or problems that arise in the limited staff member's performance should be directed to the attending or courtesy medical staff member or the director of the training program.

(a) Limited staff members may write orders for the care of patients under the supervision of the attending or courtesy medical staff member.

(ii) (b) All records of limited staff member cases must document involvement of the attending or courtesy medical staff member in the supervision of the patient's care to include co-signature of the history and physical operative report, and discharge summary.

**AMENDMENTS TO THE *BYLAWS OF THE MEDICAL STAFF OF
THE OHIO STATE UNIVERSITY HOSPITALS* (contd)**

Amended Bylaws of the Medical Staff (contd)

(E) ~~Community affiliate staff.~~

- ~~(1) Qualifications: Community affiliate staff shall consist of those physicians, as may be identified by the medical director and approved by the medical staff administrative committee and by the university hospitals board. A community affiliate staff member shall meet and maintain the same standards for quality patient care applicable to all members of the medical staff. Community affiliate staff members shall be subject to these bylaws and the rules and regulations of the medical staff except as provided in this paragraph. The community affiliate staff member shall not be required to obtain appointment to the faculty of the Ohio state university, nor shall the community affiliate staff member be subject to the requirements for board certification within the community affiliate staff member's respective area of practice. Teaching and research accomplishment shall not be required in determining the qualifications of applicants to this category of the medical staff.~~

~~To optimize the clinical organization, resource utilization, and planning of the hospitals, the medical director may require that the community affiliate physician identify categories of diagnosis, extent of anticipated patient activity, and service areas to be utilized and may prepare a statement of participation for the applicant which will be made a part of the application for appointment.~~

~~The medical director shall consult with the chief of the clinical department concerning the community affiliate applicant's qualifications. The medical director will promptly refer each applicant together with a written recommendation of the medical director and the chief of the clinical department if any, directly to the credentials committee within ten days of receipt of the completed application for review as provided in these bylaws.~~

~~(2) Prerogatives:~~

~~A community affiliate staff member may:~~

- ~~(a) Admit patients consistent with the limitations of bed and service allocations established by the medical director and approved by the medical staff administrative committee, and the university hospitals board. When, in the judgement of the medical director, a balanced teaching program is jeopardized, following consultation with the chief of the clinical department, and with the concurrence of a majority of the medical staff administrative committee, the medical director may restrict admissions of members of the community affiliate staff. Patients admitted under the care of the community affiliate staff will not be required to participate in the educational mission of the Ohio state university hospitals. Ordinarily, no coverage by the limited medical staff will be afforded, with the exception of emergency medical services.~~
- ~~(b) Exercise the clinical privileges granted, have access to all medical records, and be entitled to utilize the facilities of the Ohio state university hospitals incidental to the clinical privileges granted pursuant to these bylaws.~~
- ~~(c) Attend teaching and educational conferences approved by the Ohio state university, attend medical staff social functions, and participate as providers in~~

**AMENDMENTS TO THE *BYLAWS OF THE MEDICAL STAFF OF*
THE OHIO STATE UNIVERSITY HOSPITALS (contd)**

Amended *Bylaws of the Medical Staff* (contd)

~~the Ohio state university or the Ohio state university hospitals affiliated health plans.~~

~~(3) Responsibilities:~~

~~Each member of the community affiliate staff shall:~~

- ~~(a) Participate in the management of and represent the interests of the clinical department for which he or she is granted clinical privileges. The community affiliate staff member shall comply with all provisions of these bylaws and rules and regulations of the medical staff, unless expressly exempted under this rule. The community affiliate staff member shall comply with all the Ohio state university hospitals' policies and accreditation standards, and shall be subject to the same quality evaluation, monitoring, and resource management requirements as other members of the medical staff.~~
- ~~(b) Be responsible within the member's area of professional competence for the continuous care and supervision of each patient in the Ohio state university hospitals for whom the member is providing care, or arrange a suitable alternative for such care and supervision.~~
- ~~(c) Not be eligible to vote on medical staff policies, rules and regulations, or bylaws. The community affiliate staff member may vote for and be eligible to hold the position on the medical staff administrative committee reserved for the representative of the courtesy or community affiliate staff as set forth in paragraph (D) of rule 3335-43-09 and paragraph (D) of rule 3335-43-10 of the Administrative Code. Members of the community affiliate staff may serve on non-elected medical staff committees as provided by these bylaws.~~
- ~~(d) Be subject to payment of medical staff dues or assessments as approved by the medical staff.~~

~~(F)~~

(E)

Clinical privileges.

(1) Unchanged.

(2) Temporary privileges:

- (a) Temporary privileges may be extended to a doctor of medicine, osteopathic medicine, dental surgery, psychologist, podiatry or to a licensed health care professional upon completion of an application prescribed by the medical staff administrative committee, upon recommendation of the chief of the clinical department, and approval by the medical director. The medical director, acting as a member and on behalf of the university hospitals board, has been delegated responsibility by the university hospitals board to grant approval of temporary privileges. The temporary privileges granted shall be consistent with the applicant's training and experience and with clinical department guidelines. Prior to granting temporary privileges, primary source verification of licensure and current competence shall be required. The duration of temporary privileges shall be for a period of no more than ninety days. The granting and delineation of temporary privileges shall be consistent with the application procedures for

**AMENDMENTS TO THE *BYLAWS OF THE MEDICAL STAFF OF
THE OHIO STATE UNIVERSITY HOSPITALS* (contd)**

Amended *Bylaws of the Medical Staff* (contd)

~~clinical privileges set forth in these bylaws. Temporary privileges shall be limited to situations which fulfill an important patient-care need, and shall not be granted for a period of more than ninety days.~~

- ~~(b) Graduate medical education training rotations may be extended upon the recommendation of the chief of the clinical department, with prior concurrence of the medical director, for members of the limited staff who are not employed by the Ohio state university.~~
- ~~(c) Temporary privileges may be granted upon the recommendation of the chief of the clinical department, with prior concurrence of the medical director, for members of the limited staff who are not employed by the Ohio state university, to permit the members of the limited staff to satisfy approved graduate medical education clinical rotations of one hundred twenty days or less at the Ohio state university hospitals. In such cases, the mandatory requirement for a faculty appointment may be waived. All other requirements for medical staff membership must be satisfied.~~
- ~~(d)~~
- (b) Temporary privileges may be extended to visiting medical faculty or for special activity as provided by the Ohio state medical or dental board.

(3) through (5) unchanged.

(6) Other licensed health care professionals.

(a) through (i) unchanged.

(j) Appeal process.

(i) through (iii) unchanged.

- (iv) The affected ~~medical staff member~~ licensed health care professional shall have access to the reports and records, including transcripts, if any, of the hearing committee and of the medical staff administrative committee and all other material, favorable or unfavorable, that has been considered by the medical director. The licensed health care professional shall submit a written statement indicating those factual and procedural matters with which the member disagrees, specifying the reasons for such disagreement. This written statement may cover any matters raised at any step in the procedure to which the appeal is related, and legal counsel may assist in its preparation. Such written statement shall be submitted to the professional affairs, education and research committee no later than seven days following the date of the licensed health care professional's notice of appeal.

3335-43-08 Organization of the medical staff.

- (A) Each member of the attending medical, courtesy medical, limited, and honorary medical staff shall be assigned to a clinical department and division, if applicable, upon the recommendation of the applicable chief of the clinical department.

**AMENDMENTS TO THE *BYLAWS OF THE MEDICAL STAFF OF*
THE OHIO STATE UNIVERSITY HOSPITALS (contd)**

Amended *Bylaws of the Medical Staff* (contd)

(B) Names of clinical departments and divisions.

(1) through (3) unchanged.

(4) Internal medicine. The following divisions are designated:

- Allergy
- Cardiology
- Clinical cancer genetics
- Community internal medicine
- Dermatology
- Endocrinology and metabolism
- Digestive diseases
- General medicine
- Hematology and oncology
- Infectious diseases
- Nephrology
- Pulmonary
- Rheumatology - immunology

(5) Neurology

- Cognitive neurology
- Electrodiagnostics
- Epilepsy
- General neurology
- Multiple sclerosis and neuroimmunology
- Neuromuscular disease
- Neurooncology
- Sleep
- Stroke

(6) through (13) unchanged.

(14) Psychiatry. The following divisions are designated:

- General psychiatry
- Child psychiatry
- Sleep disorders medicine
- Geriatric psychology
- Geriatric psychiatry

(15) and (16) unchanged.

(17) Dentistry. The following divisions are designated:

- General dentistry
- Oral and maxillofacial surgery

(C) Unchanged.

**AMENDMENTS TO THE *BYLAWS OF THE MEDICAL STAFF OF*
THE OHIO STATE UNIVERSITY HOSPITALS (contd)**

Amended Bylaws of the Medical Staff (contd)

- (D) Qualifications and responsibilities of the chief of the clinical department.

The academic department chairperson shall ordinarily serve also as the chief of the clinical department. Each clinical department chief shall be qualified by education and experience appropriate to the discharge of the responsibilities of the position. Each clinical department chief must be board certified by an appropriate specialty board or must establish comparable competence. Such qualifications shall be judged by the respective dean of the college of medicine and public health or dentistry. Qualifications for chief of the clinical department generally shall include: recognized clinical competence, sound judgment and well-developed administrative skills.

(1) and (2) unchanged.

- (3) Duties of the chief of the clinical department.

Each clinical department chief shall:

(a) through (d) unchanged.

(e) Review the clinical performance including the physical and mental health of all medical staff members and other licensed health care professionals of the clinical department in accordance with these bylaws and make recommendations for appointment and reappointment to the medical staff and for clinical privileges for each medical staff member of the clinical department.

Balance unchanged.

3335-43-09 Elected officers of the medical staff of the Ohio state university hospitals.

- (A) Chief of staff.

The chief of staff shall:

(1) through (6) unchanged.

(7) Fill any vacancy which occurs in the position of courtesy ~~or community-affiliate~~ medical staff representative to the medical staff administrative committee.

(8) and (9) unchanged.

- (B) and (C) unchanged.

- (D) Representative of the courtesy ~~and community-affiliate~~ medical staff.

(1) There shall be a member of the courtesy ~~and community-affiliate~~ medical staff, elected solely by courtesy ~~and community-affiliate~~ medical staff members, who shall serve on the medical staff administrative committee as provided by paragraph (D) of rule 3335-43-10 of the Administrative Code.

(2) The courtesy ~~or community-affiliate~~ medical staff member representative shall be selected from nominations made from the floor by members of the courtesy ~~and community-affiliate~~ medical staff at a meeting scheduled for that purpose. Nominees

**AMENDMENTS TO THE *BYLAWS OF THE MEDICAL STAFF OF
THE OHIO STATE UNIVERSITY HOSPITALS (contd)***

Amended Bylaws of the Medical Staff (contd)

shall be submitted in writing to all members of the courtesy and ~~community-affiliate~~ medical staff for voting no later than March first of the election year.

- (3) Unchanged.
- (4) Any vacancy shall be filled from among the membership of the courtesy medical staff by the chief of staff. The member so appointed shall serve until the next scheduled election, unless removed by a majority vote upon written ballot of the courtesy and ~~community-affiliate~~ medical staff. Grounds for removal shall be the same as referenced in paragraph (F)(6) of this rule.
- (5) No other provisions of this rule shall apply to the courtesy and ~~the community-affiliate~~ medical staff representative. Members of the courtesy medical staff shall not be eligible to vote for or hold other elected office in the medical staff organization.

(E) through (G) Unchanged.

(H) Vacancies in office.

(1) and (2) unchanged.

(3) Vacancies in the at-large representatives and courtesy or ~~community-affiliate~~ medical staff positions shall be filled by appointment by the chief of staff.

3335-43-10 Administration of the medical staff of the Ohio state university hospitals.

(A) and (B) unchanged.

(C) Medical staff administrative committee:

(1) Composition.

(a) This committee shall consist of the following voting members: chief of staff, chief of staff-elect, chiefs of the clinical departments, three medical staff representatives elected at large, one medical courtesy or ~~community-affiliate~~ staff representative, the medical director, and the executive director of the Ohio state university hospitals. The medical director shall be the chairperson and the chief of staff shall be vice-chairperson.

(b) Unchanged.

(c) All members of the committee shall attend, either in person or by proxy, a minimum of two-thirds of all committee meetings.

(2) and (3) unchanged.

(4) Voting. At a properly constituted meeting, voting shall be by a simple majority of members present except in the case of termination or non-reappointment of medical staff membership or permanent suspension of clinical privileges, wherein a two-thirds vote of members present shall be required.

**AMENDMENTS TO THE *BYLAWS OF THE MEDICAL STAFF OF*
THE OHIO STATE UNIVERSITY HOSPITALS (contd)**

Amended Bylaws of the Medical Staff (contd)

(D) Credentials committee:

(1) Composition:

The committee shall consist of ~~nine~~ eleven members of the medical staff. Appointments to the committee shall be in accordance with paragraph (B) of this rule. The chairperson of the committee shall be appointed jointly by the medical director and the chief of staff.

(2) Duties:

(a) To receive, through the office of the medical director, all applications for medical staff and licensed health care professional appointment and reappointment, following recommendation of the chief of the clinical department and receive all requests for delineation, renewal, or amendment of clinical privileges;

(b) To review all applications for medical staff and licensed health care professional appointment and reappointment, as well as all requests for delineation, renewal, or amendment of clinical privileges in the manner provided in these medical staff bylaws, including applicable time limits;

(c) through (j) unchanged.

(3) Unchanged.

(E) Committee for physician health.

(1) Unchanged.

(2) Duties:

(a) To consider issues of physician health or impairment ~~when~~ whenever a self referral or referral is requested ~~to do so~~ by an affected member or another member or committee of the medical staff, the Ohio state university hospitals staff, or any other individual.

(b) To educate the medical staff and the Ohio state university hospitals staff about illness and impairment recognition issues specific to physicians. At a minimum there will be an educational presentation made at each medical staff meeting as required by paragraph (A) of rule 3335-43-11 of the Administrative Code.

(c) and (d) unchanged.

(e) To advise credentials or other appropriate medical staff committees on any issues the credibility of any complaint, allegation or concern, including those affecting the quality and safety of patient care.

Balance unchanged.

(APPENDIX L)

**THE ARTHUR G. JAMES CANCER HOSPITAL AND
RICHARD J. SOLOVE RESEARCH INSTITUTE BOARD**

PROPOSED AMENDMENTS TO THE BYLAWS

IMPACT STATEMENT

These proposed revisions are consistent with those previously adopted by the Board of Trustees for University Hospitals. These revisions are intended to:

- streamline medical staff appointment, reappointment and corrective action processes;
- reflect administrative changes previously established by the University Board of Trustees;
- add the director of the comprehensive cancer center and the vice president for health services to the board; and remove the executive director of university hospitals;
- refine the powers and duties of The James Board.

**PROPOSED AMENDMENTS TO THE RULES AND REGULATIONS
OF THE MEDICAL STAFF**

IMPACT STATEMENT

This amendment includes changes required by the accrediting body or to be consistent with the University Hospitals bylaws. Changes clarify responsibility of order writing privileges and additional changes relate to the supervision of housestaff. Changes also clarify documentation of history and physicals.

**AMENDMENTS TO THE JAMES BOARD BYLAWS AND RULES AND REGULATIONS OF
THE MEDICAL STAFF OF THE ARTHUR G. JAMES CANCER HOSPITAL AND RICHARD J.
SOLOVE RESEARCH INSTITUTE**

Amended James Board Bylaws

3335-109-01 General.

(A) The body with ultimate responsibility to the Ohio state university board of trustees (hereinafter referred to as "university board") for establishing policy, maintaining quality patient care, and providing for organization management and planning and oversight of the financial performance of and within the Arthur G. James cancer hospital and Richard J. Solove research institute (hereinafter referred to as "CHRI") shall be the Arthur G. James cancer hospital and Richard J. Solove research institute board (hereinafter referred to as "board").

(1) The board shall be composed of:

(a) and (b) unchanged.

(c) The ~~executive~~ director of university hospitals the comprehensive cancer center;

(d) through (g) unchanged.

(h) The university senior vice president for health sciences and dean of the college of medicine and public health ~~shall be an ex-officio member of the board without vote; and~~

(i) The president of the Arthur G. James cancer hospital and Richard J. Solove research institute foundation; and

(j) The vice president for health services.

(2) Insofar as feasible, the selection criteria will ensure that the board membership will include persons with business expertise, persons with legal expertise, persons with knowledge of health care issues delivery, persons knowledgeable about the academic mission of the CHRI, and persons who can assist the CHRI in its relations with the public and governmental entities. Selection processes will incorporate the ~~affirmative action~~ diversity policies of the university.

(3) through (5) unchanged.

(B) ~~In carrying out its responsibilities as defined in rule 3335-109-02 of the Administrative Code, the board shall seek continuing guidance from health professionals, management specialists, and others with professional expertise. The board may choose to have a periodic review of CHRI activities by a board of visitors. The visitors, consisting of persons of national eminence in health care fields, would be selected in consultation with the CHRI medical staff administrative committee and the director of the CHRI.~~

3335-109-02 Power and duties.

The board shall be responsible to the university board for patient care, teaching and research activities in and financial performance of the CHRI and for ensuring that the activities conducted within support the health sciences programs of the university. Although it is understood that the university board cannot delegate its ultimate authority over and responsibility for the CHRI --

**AMENDMENTS TO THE JAMES BOARD BYLAWS AND RULES AND REGULATIONS OF
THE MEDICAL STAFF OF THE ARTHUR G. JAMES CANCER HOSPITAL AND RICHARD J.
SOLOVE RESEARCH INSTITUTE (contd)**

Amended James Board Bylaws (contd)

including determination of policy for the fiscal health of the CHRI, its personnel policies, or the definition of the CHRI mission statement -- the board shall be delegated the authority and responsibility set forth herein, consistent with Ohio law. The board shall:

(A) and (B) unchanged.

(C) Monitor quality assurance performance under all programs identified in paragraph (B) of this rule, including formation of quality assessment and improvement mechanisms and monitoring the achievement of quality standards and goals.

(D) and (E) unchanged.

(F) Assure CHRI's compliance with federal and state laws Monitor the implementation of the university medical center integrity program as adopted by the university board.

(G) Unchanged.

(H) Approve appointments to the medical staff, clinical privileges, and disciplinary actions upon the recommendation of the appropriate official, ~~subject where required to final action of the university board~~ and/or medical staff administrative committee.

(I) Unchanged.

(J) Review ~~current and proposed operational~~ approve operating and capital budgets prior to their submission to the university board.

(K) ~~Provide advice and counsel to the university board or its designee on matters of institutional income and expenditures, fees for institutional services, and utilization of CHRI services~~ Monitor financial performance of CHRI including the achievement of financial goals and targets.

(L) ~~Develop~~ Consistent with the strategic plan for the university medical center, develop and maintain, with participation by the medical staff, the nursing department, other departments and services, and appropriate advisers, a five-year financial and operational strategic plan for the CHRI with continuous monitoring of the plan.

(M) through (O) unchanged.

(P) ~~Monitor the review and revision of all section/service policies and procedures to assure such are made by the medical staff, staff of sections/services, and others as appropriate. The period between reviews shall not exceed three years~~

(~~Q~~) Monitor and annually evaluate the performance of the director of the CHRI.

(~~R~~)

(~~Q~~) Unchanged.

(~~S~~)

(~~R~~) Unchanged.

**AMENDMENTS TO THE JAMES BOARD BYLAWS AND RULES AND REGULATIONS OF
THE MEDICAL STAFF OF THE ARTHUR G. JAMES CANCER HOSPITAL AND RICHARD J.
SOLOVE RESEARCH INSTITUTE (contd)**

Amended James Board Bylaws (contd)

3335-109-03 Accountability.

To ensure that the university board meets its governance obligations under Ohio law, the board will be accountable through the university president, the senior vice president for health sciences, and the vice president for health services to the university board.

- (A) ~~Recommendations and reports of the board that require the university board's review or action will be communicated through the university president to the university board.~~
- (B) The university board will continue to hold the university president, the senior vice president for health sciences, and the vice president for health services responsible for the conduct of the academic programs and for ensuring that the CHRI is operated in a manner consistent with university policy and state and federal law.

3335-109-04 Chief executive officer.

- (A) The director of the CHRI shall have authority as conferred by the senior vice president for health sciences and dean of the college of medicine and public health, the vice president for health services and the board. The director shall be responsible for the operation of the CHRI and shall serve as the chief executive and operating officer. The director will coordinate and prioritize matters of capital medical equipment, clinical space, and clinical programs.
- (B) Unchanged.
- (C) The appointment of the director of the CHRI shall be approved by the university board upon recommendation of the university president, senior vice president for health sciences, and the vice president for health services following consultation with the board.
- (D) and (E) unchanged.

3335-109-05 Meetings and notice.

- (A) and (B) unchanged.
- (C) A quorum for meetings of the board shall be a simple majority of the members thereof. A majority vote of those members who are present and voting shall be required for approval of any proposal, ~~except as otherwise provided herein.~~
- (D) Unchanged.

3335-109-06 Officers of the board.

- (A) The officers of the board shall be members of the board and shall consist of a chair, a vice chair, and such other officers as the board may deem advisable. The chair, chosen from the university board members, and vice chair shall be ~~elected~~ appointed annually by the university board.

**AMENDMENTS TO THE JAMES BOARD BYLAWS AND RULES AND REGULATIONS OF
THE MEDICAL STAFF OF THE ARTHUR G. JAMES CANCER HOSPITAL AND RICHARD J.
SOLOVE RESEARCH INSTITUTE (contd)**

Amended James Board Bylaws (contd)

(B) Duties of officers.

(1) Chair. The chair of the board shall preside at all meetings of the board; shall be responsible for approving agenda for board meetings; shall report to the university board as required; shall appoint all committee members; ~~shall serve as an ex-officio member, without vote, on all committees unless otherwise specified in the bylaws.~~ The chair shall have such other and further duties and authority as may be prescribed elsewhere in these bylaws, or from time to time by the board.

(2) Unchanged.

3335-109-12 Conflict of interest.

~~The board provides for full disclosure of the ownership and control of the hospital and of any health care delivery organizations that are corporately and functionally related to the hospitals. Board members shall not initiate or participate in institutional decisions involving direct benefit to themselves. In addition to any restrictions or obligations set forth in Chapter 102 of the Revised Code, and recognizing that board members and committee members have a duty of loyalty and fidelity to the university and to the university medical center and that they must govern its affairs honestly, exercising their best care, skill and judgment for the benefit of the university medical center so as to avoid even the appearance of impropriety, the members of the board and its committees shall disclose to the board any situation wherein such person has a conflict of interest that could possibly cause that person to act in other than the best interest of the university medical center and the CHRI. In any such situation the member shall abstain from acquiring any information developed by the university medical center and the CHRI and from participating in any discussions or voting related to such situation. In addition, all members of the board and its committees shall keep confidential all sensitive information of every kind including the strategic goals of groups, entities or subdivisions within the university medical center to the extent permitted by law. Members of the board and its committees also shall abide by all confidentiality and conflict of interest policies and programs adopted by the Ohio state university board of trustees from time to time.~~

3335-109-13 Relationship of CHRI to health sciences, academic, and research programs.

The health sciences colleges of the university carry out a significant portion of their educational and research activity in the CHRI. Although the board has not been delegated specific responsibilities for academic programs, it shall lend its best efforts to assure that the programs of the health sciences colleges are effectively supported in collaboration with the patient care programs of the CHRI. The senior vice president for health sciences and dean of the college of medicine and public health and vice president for health services shall be charged with maintaining an effective liaison between the health sciences colleges and the board to assure excellence in both academic and patient care programs.

3335-109-15 Medical staff organization.

~~The board, by recommendation of the board, and within a reasonable period of time shall approve and authorize the organization of the medical staff to discharge those duties and responsibilities assigned to it by the board and specifically to accomplish the following purposes, among others:~~

(A) Unchanged.

**AMENDMENTS TO THE JAMES BOARD BYLAWS AND RULES AND REGULATIONS OF
THE MEDICAL STAFF OF THE ARTHUR G. JAMES CANCER HOSPITAL AND RICHARD J.
SOLOVE RESEARCH INSTITUTE (contd)**

Amended James Board Bylaws (contd)

- (B) To timely recommend to the medical staff administrative committee and the board ~~for submission to the university board,~~ the appointment or reappointment of an applicant to the medical staff of the CHRI, the clinical privileges such applicant will enjoy in the CHRI, and any appropriate action that may be necessary in connection with any member of the medical staff.

(C) and (D) unchanged.

3335-109-17 Appointment to the medical staff and assignment of clinical privileges.

Upon recommendation of the medical staff and in accordance with the medical staff bylaws, the ~~university board, by recommendation of the board,~~ may appoint ~~faculty members who are graduates of recognized medical, dental and other professional schools~~ physicians, psychologists, podiatrists, and dentists, meeting the qualifications prescribed in the medical staff bylaws, to membership on the medical staff of the CHRI and shall grant clinical privileges to such persons, ~~subject to ratification by the university board.~~ Appointment to the medical staff carries with it full responsibility for treatment of individual patients subject to such limitations as may be imposed by the board or by bylaws and rules and regulations of the medical staff. Appointments to the medical staff shall be for two years, renewable in accordance with the reappointment procedure set forth in the medical staff bylaws. Reappointments to the medical staff will be made bi-annually by the board, and shall be for two years.

3335-109-19 CHRI clinical services.

Appointment of the chief of each clinical service is subject to approval by the ~~university board on recommendation of the board,~~ senior vice president for health sciences and director of the CHRI. All such appointments shall be periodically reviewed by the board. Chiefs of clinical services vacancies may be filled on an interim basis at any time by action of the director of the CHRI after consulting with the board.

Amended Medical Staff Rules and Regulations

04 ORDER WRITING PRIVILEGES.

- (A) Definition of "Patient Orders".

A patient order(s) is a prescription for care or treatment of inpatients, outpatients or emergency patients which is written, dictated verbally to an RN, RPh, physician assistant or RRT and signed by a medical practitioner. Patient orders may be written initially, renewed, discontinued or canceled.

- (B) Responsible medical practitioner.

All patient care is the responsibility of the attending, associate attending, clinical attending, community oncologist or community associate staff. Coverage may be provided by the limited staff under supervision. The licensed physician, dentist or podiatrist (under medical doctor supervision) member of the staff with appropriate clinical

**AMENDMENTS TO THE JAMES BOARD BYLAWS AND RULES AND REGULATIONS OF
THE MEDICAL STAFF OF THE ARTHUR G. JAMES CANCER HOSPITAL AND RICHARD J.
SOLOVE RESEARCH INSTITUTE (contd)**

Amended Medical Staff Rules and Regulations (contd)

privileges responsible for the hospitalization or outpatient care, and treatment of the patient is responsible for all orders for the patient. Attending, associate attending and clinical medical staff may designate members of the limited staff to write orders under their direction. The attending staff member may also designate members of the pre-M.D. medical student group to write orders, but in all cases the orders shall be signed by the physician, dentist, podiatrist, or designated limited staff member who has the right to practice medicine, dentistry or podiatry and who is responsible for that patient's care prior to the execution of the order. Supervising physicians may delegate to members of their physician assistant staff the ability to relay, enter, transcribe or write orders for routine laboratory, radiologic and diagnostic studies under their direction, but, in all cases, the order shall be co-signed by the supervising physician within 24 hours of the order being written. Community oncologist attending or community associate staff coverage may be provided by limited staff under supervision. ~~Orders may not be written or received by physician assistants or other paramedical personnel. All written orders must be signed by the medical practitioner prior to the execution of the order(s) by the hospital or outpatient nursing staff or other professional groups.~~

Patient orders written by "off-service" house officers or consultant staff must be countersigned by the responsible practitioner or his designee. Exception may be made in the event of preoperative orders or in the instance of acknowledged co-management: e.g. the intensive care unit or recovery room.

(C) through (M) unchanged.

07 SURGICAL CASE REVIEW (TISSUE COMMITTEES).

Surgical case review shall be performed on an on-going basis, ~~at least monthly,~~ by each department, ~~as appropriate,~~ regularly doing surgical procedures in conjunction with the clinical quality management committee. The review shall include indications for surgery and all cases in which there is a major discrepancy between preoperative and postoperative (including pathologic) diagnoses. Discrepancies between the clinical impression and tissue removed during a surgical procedure are identified by pathology and then referred to the appropriate department ~~performing surgical procedures~~ for review. A screening mechanism based on predetermined criteria may be established for cases involving no specimens. Written records of the evaluations and any action taken shall be maintained in the quality and operations improvement division department, and be available to the director of medical affairs, or the director's designee and the clinical CHRI section chief, or department chairperson or their designee designees.

09 COMMITTEES.

In addition to the medical staff committees, the medical staff shall participate in the following hospital and monitoring functions: infection control, clinical quality management, safety, and disaster planning and in other leadership council for clinical value enhancement advisory policy groups.

Medical Records Committee

(A) Unchanged.

**AMENDMENTS TO THE JAMES BOARD BYLAWS AND RULES AND REGULATIONS OF
THE MEDICAL STAFF OF THE ARTHUR G. JAMES CANCER HOSPITAL AND RICHARD J.
SOLOVE RESEARCH INSTITUTE (contd)**

Amended Medical Staff Rules and Regulations (contd)

- (B) Each member of the medical staff shall conform to the policies established by the medical records committee, including the following:
- (1) Unchanged.
 - (2) Deadlines and sanctions.
 - (a) ~~The complete history and physical examination shall be dictated or written on the patient's chart no later than twenty-four hours after admission of the patient. If the history and physical examination is dictated, a summary of pertinent findings must be recorded in the patient's chart within twenty-four hours after admission. A history and physical appropriate to the patient and the patient's chief complaint shall be documented in the medical record of all ambulatory patients.~~ A history and physical examination may be completed prior to admission, surgery or the patient's initial visit and accepted as part of the medical record if completed within thirty days preceding the admission, surgery or visit. ~~Upon admission If the history and physical examination is completed greater than seven days but within 30 days of admission or outpatient visit,~~ notation shall be made in the ~~progress notes~~ history and physical to indicate review and any updates ~~to the history and physical.~~ The history and physical examination must be performed by a member of the medical staff or his/her designee and be signed and dated. In the event the history and physical examination is performed by a physician extender, it shall be countersigned by the responsible medical staff member. Oral surgeons and dentists are responsible for portions of the history and physical exam related to dentistry.

Balance unchanged.

Lab Animal Facilities**315-2002-904****PROJECT CAPTAIN:**

Thomas A. Heretta, Facilities Planning & Development - Architecture, 292-1082

REQUESTING AGENCY:

College of Medicine and Public Health

PROJECT LOCATION:

V0001-Various Locations-Columbus

AGE:**GR. SQ. FT.:****PROJECT DESCRIPTION:**

This project will construct an addition to the existing Wiseman Hall of approximately 20,000 assignable square feet for the University Lab Animal Resources department (ULAR). This space will also connect to the Biomedical Research Tower project (315-1999-940).

MILESTONES:

	Projected	Revised	Actual
Arch/Eng Approved B/T	06/07/2002		
Constr Mgr Approved B/T	06/07/2002		
Bidding Approved B/T	12/01/2003		
Arch/Eng Contract	10/01/2002		
Schematic Design Approval	12/15/2002		
Design Development Approval	06/15/2003		
Construction Document Approval	12/31/2003		
Bid Opening	03/31/2004		
Award of Contracts	06/01/2004		
Construction Start	06/15/2004		
Report of Award to B/T	07/01/2004		
Completion	06/30/2007		

FUNDING INFORMATION:

Future Univ. Bond Issues	\$	9,250,000		
Future Capital Appropriations		6,500,000		
Total	\$	15,750,000		

USES:

% of Art	\$	65,000	\$	65,000	
Commiss. Contin		-		69,786	
Commissioning		-		45,000	
Constr. Mgr.		590,898		590,898	
Construction		10,532,950		11,253,486	
Contingency		1,504,104		1,196,310	
Design		859,489		918,284	
Equipment		1,342,951		1,147,856	
Master Planning		210,659		225,070	
Moving Cost		81,023		77,610	
Univ Administration		150,411		160,700	
Total	\$	15,337,485	\$	15,750,000	

COMMENTS:

The timeline for this project will be integrated with the Biomedical Research Towers (315-1999-940). Local administration granted by the Department of Administrative Services and Ohio Board of Regents.

Lab Animal Facilities

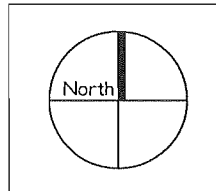
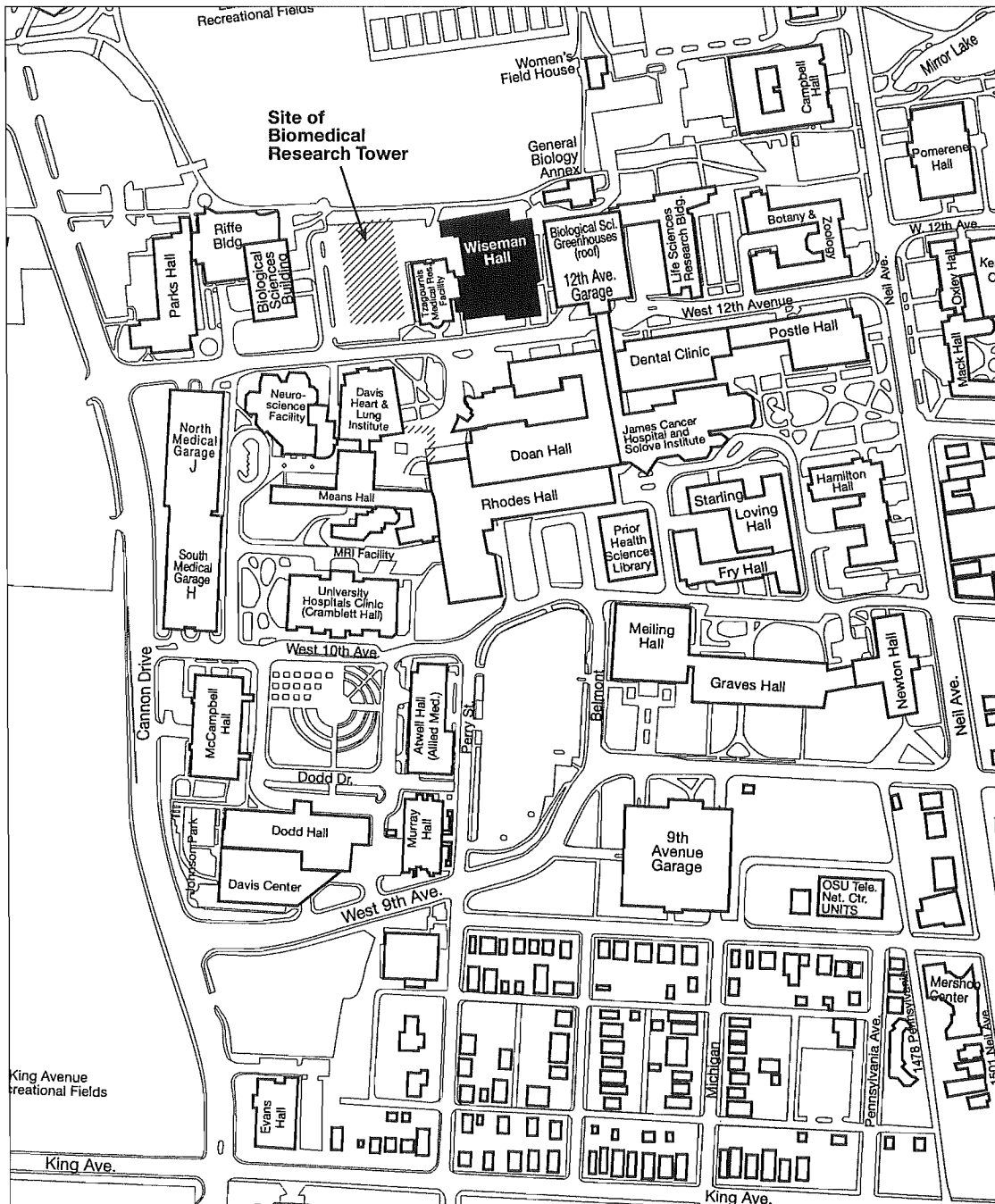

Office of Business and Finance
Office of Facilities Planning and Development

May 17, 2002

Prior Health Sciences Library Basement Renovation

50700-R025171

PROJECT CAPTAIN:

Christine Lawson, Facilities Planning & Development - Architecture, 292-2165

REQUESTING AGENCY:

College of Medicine and Public Health

PROJECT LOCATION:

0302-Prior Health Sciences Library

AGE:

1973

GR. SQ. FT.:

106,543

PROJECT DESCRIPTION:

Renovate space in the basement of the Prior Health Sciences Library to accommodate a Clinical Skills Lab to teach clinical skills for the College of Medicine and Public Health.

MILESTONES:

	Projected	Revised	Actual
Arch/Eng Approved B/T	04/07/2002		
Bidding Approved B/T	06/07/2002		
Arch/Eng Contract	10/15/2002		
Schematic Design Approval	01/31/2003		
Design Development Approval	01/31/2003		
Construction Document Approval	04/15/2003		
Bid Opening	06/16/2003		
Award of Contracts	08/01/2003		
Construction Start	08/04/2003		
Report of Award to B/T	09/01/2003		
Completion	02/13/2004		

FUNDING INFORMATION:

College of Medicine and Public Health	\$	1,000,000	
Total	\$	1,000,000	

USES:

Construction	\$	800,000	
Contingency		108,000	
Design		80,000	
Univ Administration		12,000	
Total	\$	1,000,000	

COMMENTS:

Meiling Hall Lobby Expansion

50700-R025170

PROJECT CAPTAIN:

Christine Lawson, Facilities Planning & Development - Architecture, 292-2165

REQUESTING AGENCY:

College of Medicine and Public Health

PROJECT LOCATION:

0281-MEILING HALL

AGE:

1970

GR. SQ. FT.:

76,489

PROJECT DESCRIPTION:

Renovate lobby areas on the first floor of Meiling Hall to create additional offices.

MILESTONES:

	Projected	Revised	Actual
Arch/Eng Approved B/T	06/07/2002		
Bidding Approved B/T	06/07/2002		
Arch/Eng Contract	10/15/2002		
Schematic Design Approval	01/31/2003		
Design Development Approval	01/31/2003		
Construction Document Approval	04/15/2003		
Bid Opening	06/16/2003		
Award of Contracts	08/01/2003		
Construction Start	08/04/2003		
Report of Award to B/T	09/01/2003		
Completion	02/13/2004		

FUNDING INFORMATION:

College of Medicine and Public Health	\$	750,000	
Total	\$	750,000	

USES:

Construction	\$	600,000	
Contingency		81,000	
Design		60,000	
Univ Administration		9,000	
Total	\$	750,000	

COMMENTS:

Meiling Hall - Lobby Expansion

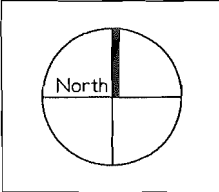
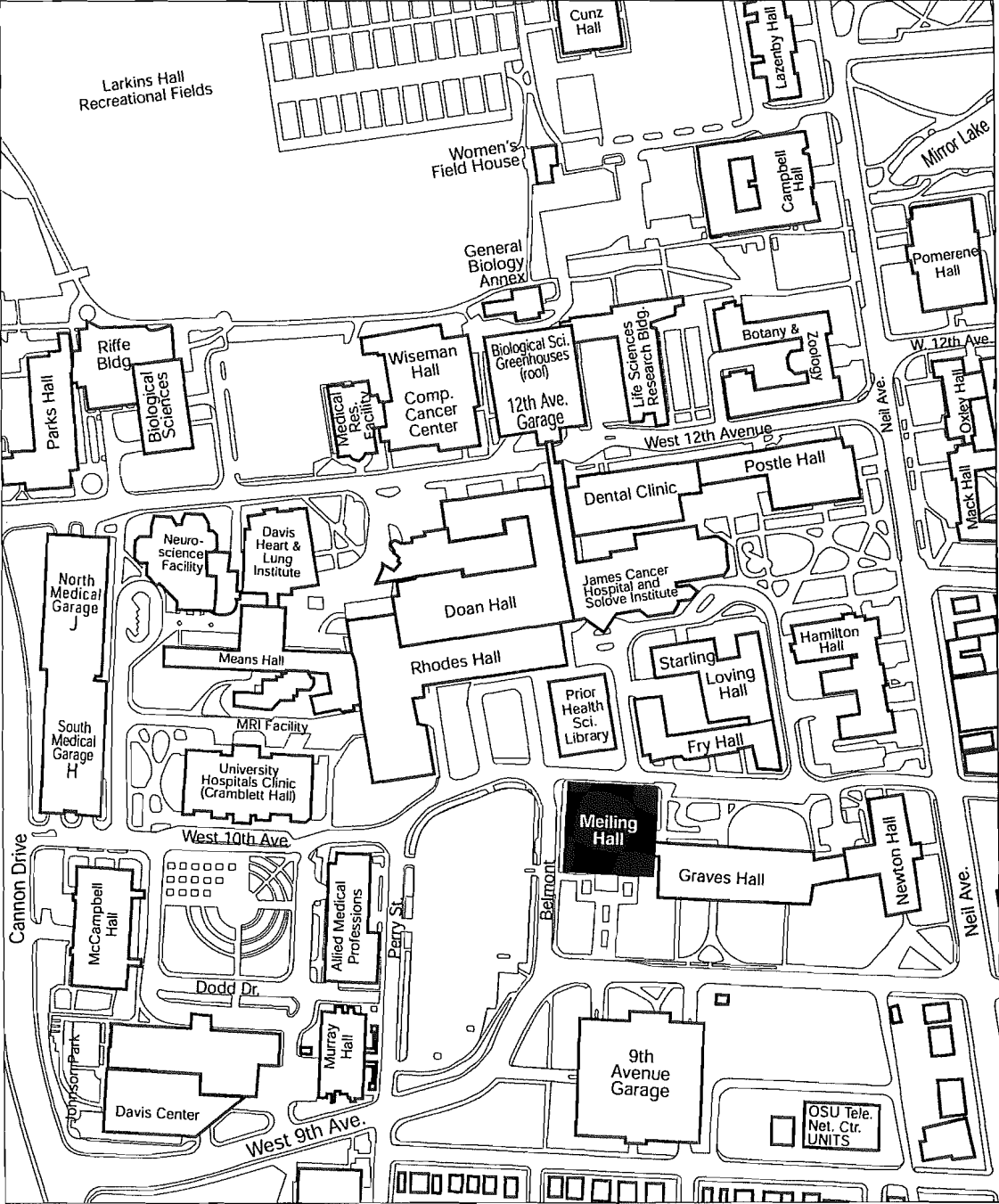

Office of Business and Finance
Office of Facilities Planning and Development

May 15, 2002

(APPENDIX LII)

ACCEPTANCE OF A GIFT OF REAL PROPERTY

MELLINGER FARM
325.88 ACRES LOCATED IN JEFFERSON, OHIO

Background

Location and Description

The property, owned by Patricia Quinby and the Estate of Virginia Miller Reed, is a farm of approximately 326 acres located on Old Lincoln Road in Jefferson, Ohio, about five miles from Wooster and the Ohio Agricultural Research and Development Center. The property contains four residences, a large bank barn, several outbuildings and concrete silos, and about 189 tillable acres. The farm is managed under lease to Farmer's National Company.

Terms of the Gift

Ms. Quinby and the Estate of Ms. Reed have executed a gift agreement whereby Ms. Reed's Estate will make a gift of her undivided one-half interest in the Mellinger Farm property to The Ohio State University Foundation. Ms. Quinby initially will transfer her interest in an approximately 16-acre tract south of State Route 30 to the Foundation immediately; the balance of her interest will be transferred to the University in two installments, the first installment in three years and the second installment three years after that.

The Foundation and Ms. Quinby each will execute an easement with the Ohio Department of Agriculture and the Killbuck Watershed Land Trust, Inc. to ensure that the entire farm property remains dedicated to agricultural uses.

In accordance with the gift agreement, the Foundation will sell the 16-acre parcel south of U.S. Route 30 shortly after the initial gift, with the proceeds placed in an existing OARDC endowment to be used to support research and educational programs on the property. As soon as practicable after the easement has been granted, the Foundation will transfer its interest in the remaining farm property to the University, with title being taken in the name of the State of Ohio for the use of The Ohio State University.

Based on an appraisal conducted by Harvey and Associates in September 2001, the Mellinger Farm has a value of \$1,170,000. There is a phase-one environmental report by our Environmental Health and Safety Office that shows an abandoned oil and gas well on the property, but no issues of concern.

Use of the Property

OARDC initially will continue rental of the farm jointly with Ms Quinby and will receive one half of the profits from the property. Upon the completion of the Quinby gift, the ultimate use for the property will be the development of a long-term research, education and demonstration program for integrated systems of forestry, crops and livestock by OARDC. OARDC will be responsible for all costs of acquisition and operation of the property.

Mellinger Farm

325.88 Acres

Jefferson, Ohio

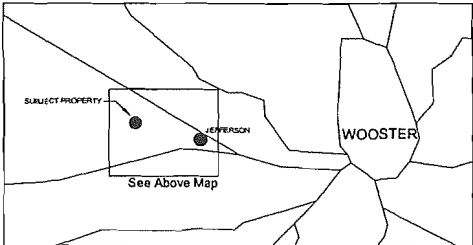
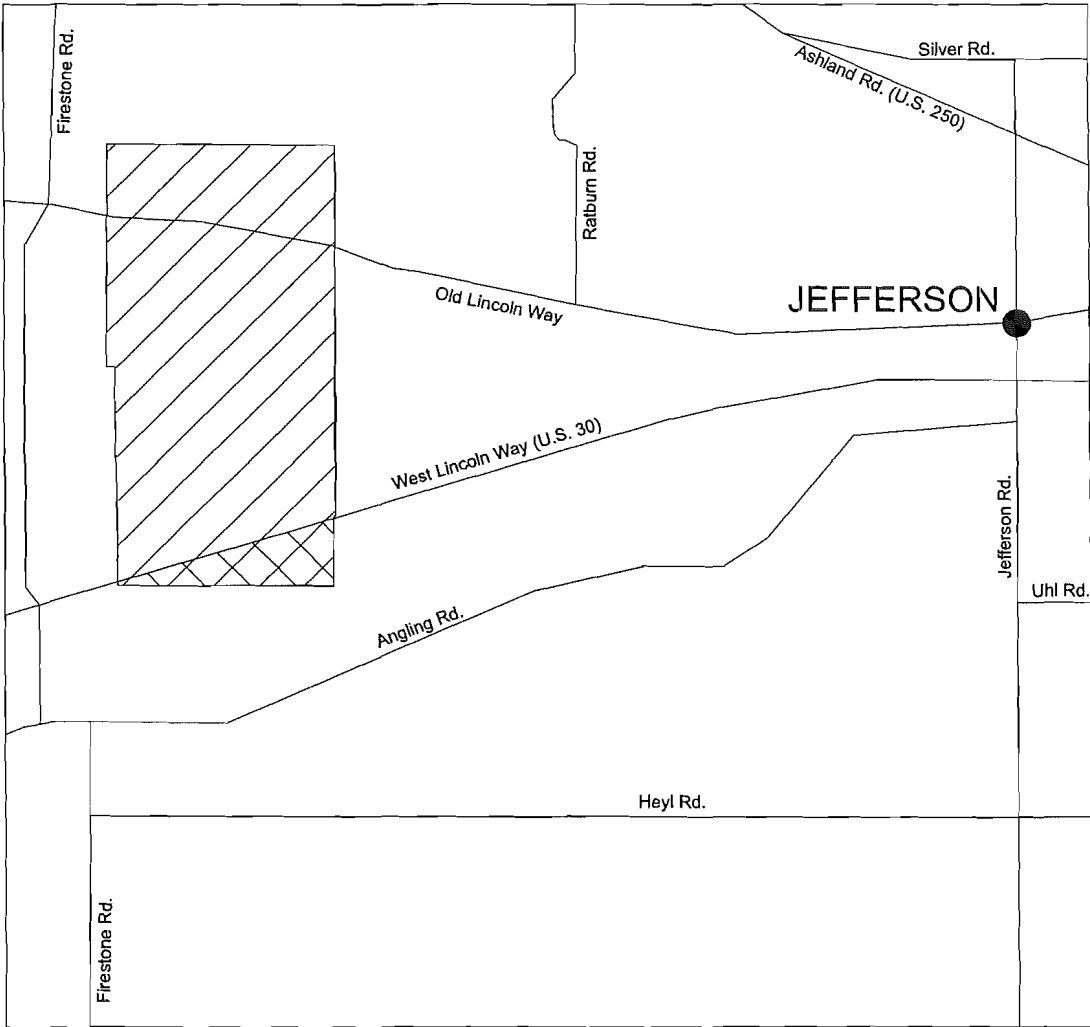

Map Provided by University Engineer's Office
No True Scale

Office of Business and Finance
Board of Trustees Meeting
June 7, 2002

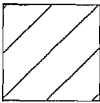

Subject Property

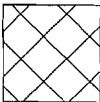

Property To Be Sold

(APPENDIX LIII)

FISCAL AFFAIRS COMMITTEE
The Ohio State University Board of Trustees
June 7, 2002

TOPIC:

Third Quarter Budget Report

CONTEXT:

This is the third in a series of quarterly reports for FY 2002.

FY 2002 HIGHLIGHTS:

- State Support for all Campuses was previously reduced by \$26.2 million as a result of the 6% executive budget cut net of enrollment adjustments.
- Indirect Cost Recoveries for Sponsored Research and Private Grants and Contracts are \$8.8 million above the original budget.
- Enrollments for all quarters were higher than projected (Attachment 1)
 - ✓ Total enrollments up 2.1%
 - ✓ Financial impact, net of additional fee authorizations for FY 2002 above the original budget, is an increase of \$8.6 million in tuition revenues (gross increase in tuition revenues of \$11.6 million).
- As a result of the increased enrollments and tuition income, a \$5.0 million enrollment reserve is maintained as a risk management reserve to guard against future uncertainty.

3RD QUARTER ADJUSTMENTS:

- Enrollments above projections for Spring Quarter will increase tuition revenues by \$1.3 million net of fee authorizations.
- Indirect Cost Recoveries from sponsored research programs through the first nine months are higher than projected.
 - ✓ Indirect Cost Recoveries up 13%.
 - ✓ Financial impact is projected to be \$8.8 million, down \$1.5 million from the second quarter projection as a result of a change to a more accurate projection model, not a downturn in research.
 - ✓ These moneys are earmarked by the University for investment in research infrastructure and possible distribution to the colleges in FY 2003 in accordance with the principles of Budget Restructuring.
- Ohio State University Health System finances show improvement with a negative \$1.96 million for the nine months compared to a minus \$8.97 million last year and with the budget target at a positive \$2.8 million. (Attachment 2)
 - ✓ Strong third quarter results helped offset a weaker than expected first half of the fiscal year.

- Athletics is meeting financial targets but will continue to be monitored. For the Schottenstein Center, revenue projections are slightly under budget and utility expenses are projected to be over budget resulting in approximately a \$100,000 year-end deficit. Its cash position remains positive.

RECOMMENDATIONS:

- Revise the Current Funds budget as of the third quarter to reflect revenue and expenditure adjustments outlined above.

REQUESTED OF FISCAL AFFAIRS COMMITTEE:

Recommend Board of Trustees approval of the third quarter budget resolution.

Headcount Enrollments
Summer & Autumn 2001 and Winter and Spring 2002

Category	Projected ¹	Actual ²	Difference	% Change
Undergraduate	113,214	115,935	+2,721	+2.4%
Graduate	35,103	35,516	+413	+1.2%
Professional	9,031	9,256	+225	+2.5%
Total	157,348	160,707	+3,359	+2.1%

NOTE: Includes total of Summer, Autumn, Winter and Spring Quarters

SOURCE: Resource Planning

¹ Projected in May 2001 for FY 2002 budget.

² Reflects 14th day enrollment counts

THE OHIO STATE UNIVERSITY HEALTH SYSTEM
FINANCIAL SUMMARY

YTD Ending March 31, 2002
(In Thousands)

	Actual 2002 (9 Months)	Budget 2002 (9 Months)	Actual 2001 (9 Months)
Net Patient Revenue	\$491,303	\$468,483	\$417,682
Other Income	31,972	32,636	30,190
Total Income	\$523,275	\$501,119	\$447,872
Expenses	\$525,235	\$498,360	\$456,846
Revenue Over Expenses	\$-1,960	+\$2,759	\$-8,974

SOURCE: The Ohio State University Health System
May 21, 2002

SUMMARY OF BUDGETED RESOURCES AND EXPENDITURES
FY 2002 THIRD QUARTER BUDGET REPORT
(In Thousands)

	Original Budget		3rd. Quarter Budget Revision		Difference	
	General Funds	Other Funds	General Funds	Other Funds	General Funds	Other Funds
Resources						
Government Support	404,109	329,698	389,786	323,771	(14,323)	(5,927)
Student Fees	387,827	8,935	399,419	8,935	11,592	0
Auxiliaries		170,079		170,079	0	0
Hospitals		725,040		725,040	0	0
Other	35,547	254,388	40,127	264,388	4,580	10,000
Total Resources	827,483	1,488,140	829,332	1,497,213	1,849	4,073
Expenditures						
Instructional & General	736,680	167,727	756,124	174,800	19,444	7,073
Auxiliaries	1,439	175,904	1,439	175,904	0	0
Hospitals		732,869		732,869	0	0
Other	88,796	404,109	81,496	404,109	(7,300)	0
Total Expenditures	826,915	1,480,609	839,059	1,487,682	12,144	7,073
Net	568	7,531	(9,727)	4,531	(10,295)	(3,000)
One Time Adjustments						
College/Office Reallocation						
Non Gen Funds Reallocation						
Other Central Funds						
Net After Adjustments	568	7,531	(9,727)	4,531	(10,295)	(3,000)

- (1) General Funds: +\$1.9M Columbus Campus Subsidy for enrollment changes, +\$6.2M in indirect cost recoveries, -\$19.4M (6%) Columbus Campus budget cut, -\$1.2M (6%) Regional Campus budget cut, -\$1.8M (6%) line item appropriation cuts.
- Other Funds: -\$5.9M (6%) in other restricted State line item appropriations.
- (2) General Funds: +\$2.6M increase in Private Grants Indirect Cost Recoveries, +\$2.0M in Endowment Income to align with Budget vs Actual.
- (3) General Funds: +\$11.6M in Columbus Campus Fee Income due primarily to an increase in undergraduate enrollments.
- Other Funds: +\$10M in Earnings Departmental Sales & Services to reflect increased activity over budget.
- (4) General Funds: -\$1.2M in Regional Campus expenditures due to a reduction in Instructional Subsidy, -\$1.8M due to line item appropriation cuts, +\$8.8M for commitments against the increase in indirect cost recoveries, +\$7.3M from Other Expenditures to align with Budget vs Actual.
- (5) General Funds: +\$3.0M for additional graduate fee authorizations associated with increased graduate enrollments, +\$2M in additional financial aid and other unrestricted Endowment related expenditures, +\$1.2M additional Revenue Enhancement for Professional Schools due to increased enrollments.
- (6) General Funds: +\$13M in Earnings I&G to align with increase expenditures, -\$5.9M to reflect the reduction in restricted State line item appropriations.
- (7) One-Time Sources: -\$7.3M Adjustments to realign the budget to actual between Other and Instructional & General Expenditures.
- Net After Adjustments: The \$7.2M increase in the General Fund is due to fee increases and will be held centrally mostly in an Enrollment Reserve because of uncertainty regarding resources.

(APPENDIX LIV)

FISCAL AFFAIRS COMMITTEE
The Ohio State University Board of Trustees
June 7, 2002

FY 2002-03 TUITION AND FEE RECOMMENDATIONS

- I. Context
- II. Recommendations
- III. Implications
- IV. Conclusions
- V. Additional Information

Office of Academic Affairs
Office of Business and Finance

I. Context

A. Review of benchmarking comparison:

1. Revenues per student FTE at Ohio State (\$6,164 per FTE student) are significantly less (18%) than the benchmark institution average³.
2. State support per student FTE at Ohio State is also significantly less (\$615 or 6.3%) than at benchmark institutions¹.
3. Resident undergraduate fees at Ohio State are significantly below the average (\$158 per student or 3.2%) for benchmark institutions⁴.
4. Resident undergraduate fees at Ohio State for Autumn 2002 will rank 8th among 13 Ohio public assisted universities for continuing students and 9th for new students and are 8.5% and 2.8% below the State average, respectively⁵.

B. Conclusion

This makes Ohio State, which continues to compete effectively with its aspirational peers with respect to academic quality, increasingly at risk of falling behind in providing students with a truly outstanding education.

C. Actions to Date

The following fees have previously been approved by the Board effective Summer Quarter 2002:

1. A two-tiered budget structure for undergraduate instructional and general fees for the Columbus Campus.
2. Undergraduate instructional and general fees for the Regional Campuses.
3. Undergraduate nonresident surcharges for all campuses.

II. RECOMMENDATIONS

A. In order to maintain a competitive position financially, Ohio State needs to increase selective student fees, effective Autumn Quarter 2002.

1. Resident graduate instructional and general fees will increase \$306 per year (4.9%), or \$102 per quarter. Fees for non-resident graduate students will increase \$810 per year (4.9%).
2. Increases above 5.0% are recommended for professional and graduate student instructional fees on a selected basis in the colleges of Business, Dentistry, Law, Medicine, Optometry, Pharmacy, and Veterinary Medicine.
3. Other student fees including Housing and Food Service, Learning Technology fees, Student Insurance, Parking, and Recreational among others also need to be approved for FY 2002-03 in order to continue to provide quality services to students.

¹ Based on FY 00 IPEDS Financial Survey.

² Based on Fall 2001 AAUD Tuition and Fee Survey.

³ Based on a survey of the other 12 State universities.

- B. Instructional fees for all Graduate and Professional programs will increase by a base of 5%. Differential Fee Increases⁶ above the 5% base are recommended for the twelve graduate and professional programs listed below. These monies will be used to improve services to students in those colleges inside and outside the classroom. The nonresident surcharges for all Graduate and Professional programs will also increase by 5%. Three of the programs are charging differential fees for the first time in FY 2003 – Masters in Public Health (MPH), Masters in Public Health (PEP) and Masters in Health Administration.

College	FY 2002	FY 2003 Increases			
	Instruct. Fees	Resident Instructional Fee		Non-Resident Surcharge ²	
		% Chg	\$ Chg	% Chg	\$ Chg
Business (MBA)	\$10,983	14.1	1,548	5.0	504
EMBA	27,051	7.1	1,920	5.0	504
Dentistry	12,489	12.0	1,500	5.0	1,032
Law (semester)	10,474	10.0	1,046	5.0	544
Medicine ³	14,817	15.1	2,235	5.0	1,104
Health Admin. ⁴	5,955	30.0	1,785	5.0	504
Physical Therapy	6,210	10.0	621	5.0	504
Public Health MPH ⁴	5,955	10.0	594	5.0	504
Public Health PEP ⁴	5,955	12.0	714	5.0	504
Optometry	10,023	9.0	903	5.0	1,032
Pharmacy	7,365	12.0	885	5.0	534
Vet Medicine	11,661	10.0	1,167	5.0	1,068

¹ Annually (3 quarters or 2 semesters), unless indicated otherwise.

² Non-resident students pay both resident and non-resident fees.

³ Represents the gross instructional fees for all ranks (0,1,2 & 3). The higher ranks will receive Medicine Tuition Credits to lower their effective Rates to 11.8% increase for ranks 1 & 2 and to an 8.2% increase for rank 3.

⁴ New differential fee in FY 2003. Fee represents increase over the FY 2002 Graduate fees.

C. Other Charges and Fees

1. Summary of changes in undergraduate fees and charges:

The total cost for a resident undergraduate to attend Ohio State's Columbus Campus and live in University housing in FY 2003 will increase approximately \$838 (6.6%) for a three quarter academic year for a continuing student and \$1,312 (10.3%) for a three quarter academic year for a new student.

<u>Fees and Charges</u>	Continuing Students		New Students	
	Percent Increase	Dollar Increase	Percent Increase	Dollar Increase
Tuition	9.0%	\$429	19.0%	903
Room & Board ¹	4.7%	282	4.7%	282
Books & Supplies	5.0%	47	5.0%	47
Health Insurance ²	8.0%	60	8.0%	60
Park & OSU Bus ³	10.1%	15	10.1%	15
COTA Bus Pass	0.0%	0	0.0%	0
Football Tickets	5.0%	5	5.0%	5
Basketball Tickets	0.0%	0	0.0%	0
Total	6.6%	\$838	10.3%	\$1,312

2. Learning Technology Fees:

Several colleges and programs have established Learning Technology fees in the past in order to fund the additional technology needed to remain competitive within their fields. These fees are not proposed to increase in FY 2003.

	Quarterly Fees	
	Undergraduate	Graduate
College of Arts	\$43.00	\$43.00
College of Business	85.00	120.00
College of Engineering	110.00	120.00
College of Nursing	43.00	43.00
Dept of CIS in MAPS	73.00	80.00
School of Public Pol & Mgt	NA	120.00

3. Other increases are as follows:

Application Fees	No change
Acceptance Fees	No change
Basic Telephone Service	No change
Faculty & Staff Parking	10% increase
Faculty & Staff Health Insurance ⁴	4%-19% increase
University Health System	15% increase

¹ Represents the average undergraduate room rates plus the 10-meal plan.

² Based on the single student medical only rate.

³ Rates are for the Columbus Campus.

⁴ Traditional and OSUHP plans increasing 4.0%, Prime Care and Buckeye plans increasing 19%.
Traditional and OSUHP plans increasing 4.0%, Prime Care and Buckeye plans increasing 19%.

II. Implications

- A. Why are student fees at Ohio State increasing more than inflation?
1. The University is committed to improving itself and its value to the people of Ohio.
 2. The University is behind its competitors in faculty and staff compensation and has committed to fund an average pay increase for faculty and staff in the range of 4.5%, roughly equal to 1.0% above market.
 3. The University is embarking on a multi-year plan to improve the quality of the undergraduate learning environment and enhance student services.
 4. Although students will share in providing additional resources through higher tuition, the University will also seek other funding sources including private fund raising, sponsored research and internal reallocations through improved operations.
 5. The State of Ohio through budget cuts and zero increases in state funding, as a result of bad economic times and court rulings, continues to fall behind other states in its support for Higher Education
- B. Comparison of 9%-19% tuition increases for full-time resident undergraduates with other State universities:
1. Resident undergraduate tuition at the Ohio State University in FY 2002 will remain 8th among the 13 state universities for new students (2.8% below the state average) and will drop to 9th place for continuing students (8.5% below the state average). This compares to last Autumn when Ohio State's undergraduate fees were 4.2% below the state average.
 2. Seven of the 13 State Universities implemented mid-year undergraduate fee increases in FY 2002 and seven will implement a two-tiered fee structure for undergraduates in FY 2003.
 3. At 9.0%, Ohio State ranks 12th among the 13 State universities in percent increases between Autumn Quarter 2001 and Autumn Quarter 2002 for continuing undergraduate students. The average for the state is 14.0%.
 4. At 19.0%, Ohio State ranks 6th among the 13 State universities in percent increases between Autumn Quarter 2001 and Autumn Quarter 2002 for new undergraduate students. The average for the state is 17.3%.

Institution	FY 2002	FY 2003 ¹			
	Fall 01 Tuition	New Students		Continuing Students	
		Tuition	% Chg	Tuition	% Chg
Miami University	\$6,916	\$7,600	9.9%	\$7,600	9.9%
U of Cincinnati ²	5,823	6,936	19.1%	6,936	19.1%
Bowling Green ²	5,604	6,726	20.0%	6,486	15.7%
Kent State ²	5,598	6,374	13.9%	6,374	13.9%
Ohio University	5,493	6,336	15.3%	6,036	9.9%
U of Akron ²	4,930	6,098	23.7%	5,798	17.6%
U of Toledo	5,102	5,836	14.4%	5,836	14.4%
Ohio State	4,761	5,664	19.0%	5,190	9.0%
Cleveland State ²	4,464	5,496	23.1%	5,196	16.4%
Wright State ²	4,596	5,361	16.6%	5,163	12.3%
Youngstown State	4,204	4,996	18.8%	4,996	18.8%
Shawnee State ²	3,402	4,347	27.8%	4,050	19.0%
Central State	3,723	4,021	8.0%	4,021	8.0%
State Average	\$4,970	\$5,830	17.3%	\$5,668	14.0%

IV. CONCLUSIONS

- A. Ohio State is an excellent value for Ohio taxpayers, but is not as well funded as its competitors.
- B. Ohio State students expect and deserve the same or better level of service as students elsewhere.
- C. Ohio State will strive to continue to make improvements in the quality of services to students in FY 2003 despite low levels of State support.
- D. Ohio State continues to compete effectively with its aspirational peers with respect to academic quality. However, relatively low levels of state financial support means we are increasingly at risk of falling behind in providing students with a truly outstanding education.

¹ Sources are the individual institutions.

² Universities that implemented mid-year fee increases in FY 2002.

THE OHIO STATE UNIVERSITY
OFFICIAL PROCEEDINGS OF THE
ONE THOUSAND THREE HUNDRED AND EIGHTY-FOURTH MEETING
OF THE BOARD OF TRUSTEES

Columbus, Ohio, July 12, 2002

The Board of Trustees met at its regular monthly meeting on Friday, July 12, 2002, at The Ohio State University Arden Shisler Center for Education and Economic Development, OARDC, Wooster, Ohio, pursuant to adjournment.

**

**

**

Minutes of the last meeting were approved.

**

**

**

July 12, 2002 meeting, Board of Trustees

The Chairman, Mr. Patterson, called the meeting of the Board of Trustees to order on July 12, 2002, at 10:30 a.m. He requested the Secretary to call the roll.

Present: James F. Patterson, Chairman, Zuheir Sofia, Tami Longaberger, Daniel M. Slane, Robert M. Duncan, Karen L. Hendricks, Dimon R. McFerson, Jo Ann Davidson, Douglas G. Borrer, and Joseph A. Shultz.

--0--

CHAIRMAN'S REPORT

Mr. Patterson:

Good morning. I am happy that the Board has the opportunity to be here at OARDC and ATI in Wooster. It was one of the things that I wanted to do during my chairmanship. It has been several years –Ted Celeste was chairman -- since the Board was here last. This gives the Board an opportunity to see some of the things OARDC and ATI faculty and staff are working on and to meet in this wonderful facility that Ohio State University can take such pride in.

As you might imagine from my background, I have had the opportunity to visit a few of these facilities around the country. I still maintain that this is one of the finest facilities in the whole country. We have some extremely gifted and national professors working at OARDC and ATI, and a few will be at lunch today. Diane Miller is here in the audience this morning. Diane, wave your hand. Diane is a professor in horticulture and is one of the individuals that in my business I would work very closely with and rely heavily upon. There will be a few others at lunch that I'll introduce. Many of these people are nationally recognized as the best in the country, and many of them by virtue of that are the best in the world at what they do. We'll try and recognize them later.

Let me just say a brief word about our search process and the fact that we are in the midst of looking for a new president. As you can imagine, we are in the midst of it and my comments are not going to be terribly enlightening to you, but there are two things that have surfaced during the search that I think are worth noting.

As we begin to "spread the net," I feel very good about the extent of the people who we have begun to look at. I think I feel even better than we did the last time, to give you some comparison. We are looking at a lot of different folks. Not individually, but the groups that we're looking at and the universities that they're coming from are rather extensive.

Also, we're looking at what appears to me to be a very talented group of people. Perhaps as a whole, my judgment is – because I had the opportunity to serve on the last search committee – that the level of talent is even greater than during the last search.

There is an emphasis on people with a strong academic background and -- recognizing those things that came up as we developed our Presidential Profile – people who have expertise in working with donors, legislators, alumni, and external constituencies. It's quite obvious that this facet of being a president is taking up more and more of any president's time.

I think we're on schedule – whatever that is. We have maintained all along that we would like to have someone in place by the first of the calendar year. I have no reason to believe that we're either ahead or behind on that at this point in time. I think that's all, but I did want to mention we are looking at some good people.

CHAIRMAN'S REPORT (contd)

Mr. Patterson: (contd)

I'll conclude with that. I want to make some more remarks at lunch regarding OARDC and we will have a chance to hear a presentation on that this morning.

--0--

Mr. Patterson:

I want to introduce two new people who will be attending our Board meetings. One is Mr. Robert Meier. Robert is the new chairman of the Staff Advisory Committee, taking Willa Young's place. Robert, will you please tell us what area you are from?

Mr. Robert F. Meier:

I work with the Managed Health Care Systems at the University and also the Faculty and Staff Assistance Program.

Mr. Patterson:

Thank you very much. The new chair of the Senate Steering Committee is Professor Stanley Ahalt. Stanley, would you want to say a few remarks about the area that you're from?

Professor Stanley C. Ahalt:

I'm a computer and electrical engineer and I'm glad to be here. I'd be interested in speaking to any of your sons or daughters who are interested in coming to our department.

Mr. Patterson:

Karen Hendricks' son is really going to be under the gun. He now has you, along with his mother, twisting his arm to be an engineer.

--0--

PRESIDENT'S REPORT

President Edward H. Jennings:

Thank you, Mr. Chairman – members of the Board. You mention the meeting being here at OARDC. It was either my first or second meeting as president -- I'm not sure which one, that's 20 years ago – but we had it here at OARDC, so it's fitting that my first meeting back is at OARDC.

I'd like to start by thanking, first of all, Steve Slack, Chris Igodan, and the OARDC and ATI faculty and staff for hosting our meeting today. It's a delight to be back in this community and to note especially some of the great things that are happening on this campus.

As all of you know, last month Professor Linda Saif of the Food Animal Research Program at the Ohio Agricultural Research and Development Center here and the Department of Veterinary Preventive Medicine was named one of only two Distinguished University Professors for this year. This is truly the highest honor that we can confer upon our faculty, and I think it speaks volumes for the quality of teaching and research going on here in Wooster. The faculty, staff, and

PRESIDENT'S REPORT (contd)

President Jennings: (contd)

students at OARDC and ATI truly are doing some terrific work, and you'll hear more about some of that work in the next presentation on our agenda.

I also want to add that this new Shisler Conference Center is already proving to be a great resource to our students, to our faculty and staff, and to the community, as well. It is certainly, again, a telling example of the good things that happen from partnerships between Ohio State and the business community like the support from Nationwide Insurance that made this center possible. Dimon, I think Chairman Shisler will be joining us for lunch later today.

In my first report to the Board of Trustees as interim president of the University, my principal message is plain and simple: While the search for a new University president progresses, it's absolutely imperative that we also continue to make progress with our Academic Plan and our drive to advance our great University.

As Brit Kirwan said in his final report to this Board, "The debate is over." This is a University that is now on a trajectory to realize the aspirations of the Academic Plan and expand our reputation and scope as one of our nation's very best teaching, research, and service universities. And this is an enormously significant statement about The Ohio State University in 2002.

A great many people across this University have invested their time, their intellect, their creativity, and their passion for Ohio State into creating and implementing our ambitious plan – and we owe it to them, to our students, and to the people of Ohio to carry that plan forward.

The progress we have made shows that Ohio State is on the right track. But our drive to improve quality will never end. We can always get better. Excellence is truly a journey, not a destination.

The most effective way for us to keep moving on this track is to continue hiring and retaining outstanding faculty and staff. The University is no better or no worse than the quality of its faculty and staff. We, in recent years, have added a number of noteworthy faculty members, and I'd like to mention – with your indulgence – a few of them.

Winston Ho will be joining our Department of Chemical Engineering this fall and will be that department's second member of the National Academy of Engineering. The other is Department Chair L.S. Fan.

Also this fall, Roger Ratcliff will be joining the Department of Psychology from Northwestern University as a distinguished professor of Social and Behavioral Sciences. Professor Ratcliff is an internationally renowned expert on the mathematical modeling of human cognitive processes. And he is the most recent recipient of the Warren Medal from the Society of Experimental Psychology – the top research prize from the most prestigious group of experimental psychologists in the nation.

We will also be soon welcoming a new eminent scholar to the Department of Physics. Professor Chris Hammel is coming to Ohio State from Los Alamos National Laboratory. He is world-renowned for his work on high-temperature superconductivity and the development of the magnetic-resonance-force microscope. He will truly be a great addition to the Ohio State family.

Another new hire is Benjamin David, who is joining the History of Art Department. Professor David is one of the rising young scholars in the field of Italian

PRESIDENT'S REPORT (contd)

President Jennings: (contd)

Renaissance Art, and he has had several publications in prestigious collections and periodicals.

I am very pleased to welcome these individuals to a team of faculty and staff that is already truly outstanding. Many of our current faculty members are active doing truly outstanding work and receiving national and international recognition. And we must always keep in mind that it is our current faculty and staff doing excellent work that make Ohio State such an attractive University for our new teachers and scholars. Let me cite some examples of our current faculty and staff and their work.

Professor of Mathematics David Terman has led a team of researchers who, by using computer models, may have found the origins of tremors suffered by people with Parkinson's disease. Professor Frank DeLucia and his colleagues have developed an instrument that is allowing them to become the world's first researchers to study a rare, sulfur-containing molecule that was first synthesized by Markus Behnke, who is now, incidentally, a postdoctoral student at Ohio State. Their groundbreaking studies may help us better understand combustion, atmospheric pollution, and interstellar chemistry.

NASA selected Professor of Civil and Environmental Engineering and Geodetic Science Ron Li as a scientist for the Mars Exploration Rover 2003 mission. He is helping to design the mapping system that will help the new rover explore the surface of Mars in 2004. *Technology Review* magazine named Assistant Professor of Materials Science and Engineering and Biomedical Engineering Derek Hansford as one of the world's "100 Top Young Innovators." The magazine recognized Professor Hansford for his work fabricating very tiny medical devices out of plastic.

Parwinder Grewal, assistant professor of Entomology with OARDC here in Wooster, traveled to Spain last month to receive the Society of Nematologists' Syngenta Recognition Award for Excellence for his significant contributions to advancements in agriculture. And Professor of Art Ann Hamilton is the subject of a newly published book that analyzes two decades of her work.

I also might add that three of our coaches were named Big Ten Coach of the Year in their respective sports: Linda Kalafatis in softball; Therese Hession in women's golf; and Andy Teitelbaum in women's rowing.

I'm also very pleased to report that Judy Fountain – who is in the audience today -- the current director of The Women's Place at Ohio State, will be named today as the assistant vice provost for Women's Policy Initiatives. Judy has made The Women's Place a model program for other universities, and she has been an instrumental leader in the first year of activity of the President's Council on Women's Issues. She is a tremendous asset to the University and to the growth of opportunities for women at Ohio State. I can say that because I've had a long association with Judy, as she has been around here probably longer than I have, haven't you Judy? She is a tremendous addition to the Provost's staff.

I can talk for a long time about the importance of recruiting and retaining outstanding faculty and staff. But one new and exciting development at the University tells the story much better than I can. The Selective Investment Award that the Department of Mathematics received in 2000 enabled the department to hire National Academy of Sciences member Avner Friedman, an international expert in the combination of mathematics and the life sciences. Now, Professor Friedman is one of the leading figures responsible for the National Science

PRESIDENT'S REPORT (contd)

President Jennings: (contd)

Foundation awarding Ohio State the nation's first-ever Mathematical Biosciences Institute. Professor Friedman will serve as director of that institute.

This \$10 million institute is unique in the world, and it represents a tremendous opportunity for Ohio State. It combines our expertise in mathematics and statistics with our biomedical research initiative, and the collaborative research that takes place at the institute will put Ohio State -- and Ohio -- at the forefront of some of the most exciting and the most significant -- research going on in the early 21st century.

Another major new research award to our current faculty has come from NASA. A team of scientists from Ohio State, Georgia Tech, Florida A&M, and NASA Glenn Research Center in Cleveland was selected to establish a new NASA Center in Aero Propulsion and Power. The total award is for \$15 million over five years, and Ohio State will receive approximately half of that money to conduct research in turbo machinery and materials for turbine engines. Basically, our researchers will be trying to make airplanes lighter, tougher, cleaner, and faster. I might add that we won the award over competition from MIT, Penn State, Stanford, and the University of Cincinnati. Ohio State's principals in this effort are Professors Mike Dunn and Dean Jim Williams.

I also want to note that Professor of Chemistry Sheldon Shore recently received a \$500,000 grant from the National Science Foundation. With that award, Professor Shore has now received NSF funding for 44 consecutive years. He has truly had an incredibly productive career, and it's not over yet.

These awards represent the culmination of another exceptional year for research at Ohio State. In fact, preliminary figures indicate that research awards at the University increased more than 18 percent in Fiscal Year 2002. For the first time ever, Ohio State's research awards totaled almost \$400 million. Moreover, over the past three years, our research awards have increased by a total of about 58 percent. Clearly, these awards reflect directly on the tremendous quality of our faculty. And they represent an important part of our efforts to increase funding at the University beyond our state subsidy.

We all know these are difficult times for state agencies and state institutions. And we are very grateful to the governor for protecting higher education from the latest round of state budget cuts -- other than the six percent announced last October. We greatly appreciate that the governor and the General Assembly are aware of the higher education challenges facing Ohioans.

During these times, it is vital that we at the University on our own expand our funding sources. Obviously, our faculty are doing just that, through their hard work in attracting research awards from government, industry, and private foundations.

I am pleased to point out that the efforts of our hard-working development staff, led by Jerry May, have paid off with another very good year. We do not have final numbers yet, but based on early information, we estimate that the total private support for Ohio State will be around \$175 to \$180 million -- which is about what the total would have been for Fiscal Year 2001 without the very generous Moritz gift to the law college.

Under the difficult economic times of the past years, these are extraordinary numbers. Our development team and our very loyal alumni continue to generate funds that help us on the margin of excellence, hiring exceptional faculty, building

PRESIDENT'S REPORT (contd)

President Jennings: (contd)

state-of-the-art facilities, and promoting academic excellence across the entire University.

I'd also like to note, Mr. Chairman, one item from Athletics. Not only do we expect to have very strong teams on the playing fields this year in many sports, but we also lead the entire Big Ten in the number of student-athletes named to all-conference academic teams this past year. One hundred twenty Buckeye student-athletes received this honor. I'm enormously proud of the commitment to academics that has been made by Andy Geiger and Coach Tressel, Coach O'Brien, and all of our coaches.

The pursuit of academic excellence as well as athletic excellence is a hallmark of Ohio State. If I can just take a minute – it reminds me of a story about Woody Hayes.

Several years ago, I was at a reception for a past championship football team and the players then were in their late 30s and early 40s. It was a very happy reunion, but I noticed that about five or six of the guys wouldn't go near Woody. They would avoid Woody whenever possible. Woody would come up to them, and they'd run away.

Greg Lashutka was there, the former mayor of Columbus, the former tight end on the Ohio State football team, and a graduate of our law school. I asked Greg, "How come those guys are staying away from Woody?" And he said, "That's simple. Woody would have grabbed them by the lapels and said, 'Why haven't you finished your degree?'"

You can say what you want about Woody, but Woody was interested in academics, and so is Ohio State, and so are our current coaches.

Finally I'd like to conclude with a "thank you" to the vice presidents and deans, as well as the members of the Board of Trustees, who have already helped me tremendously in this transition. I have inherited, Mr. Chairman, a very high caliber of leadership across this University, and my job has been remarkably easy because of their insight, their expertise, and their support.

Mr. Chairman and members of the Board, that completes my report.

Mr. Patterson:

Thank you, Ed. It bears noting that while our agreement with Ed indicated that he would start July 1, in fact, he literally started immediately after our last meeting. He has been on a whirlwind meeting tour with deans, staff, legislators, and people in the community, trying to get up to speed very quickly. In the opportunities that we have to meet, he's deeply involved in this. Next thing we know, he'll be putting an application in! Barbara will be grabbing him by the neck! But the Trustees are just overwhelmed by the way he has stepped in and taken a hold of the position. For those concerned that we may lose momentum, let me assure you that it is pushing forward.

--0--

OARDC PRESENTATION

Mr. Patterson:

I want to introduce to you the gentleman who has the responsibility for OARDC. The direct responsibility ultimately rests with Bobby Moser, vice president for Agricultural Administration and University Outreach, and executive dean for Food, Agricultural, and Environmental Sciences. But here on the Wooster campus, Steve Slack is responsible for 4,000 plus acres, multiple buildings, and lots of staff. Steve will be telling you about the work that is done here at OARDC.

Dr. Steven A. Slack:

Thank you very much, Mr. Chairman, President Jennings, and the Board of Trustees. We very much appreciate the fact that you've taken time out of your busy schedules to visit with us, to give us an opportunity to share with you some of the activities that we have going on here in Wooster, and to show you some of the programs and facilities of which we are exceedingly proud and pleased.

I think it goes without saying that you're sitting in one of the jewels of the campus and that's also been referred to previously by President Jennings. It really represents a lot of the program effort that goes on through OARDC and ATI. That is that it is a joint partnership -- a public-private partnership. Simply, this facility would not be here without that kind of a relationship.

We hold that kind of relationship broadly with stakeholders across the State of Ohio. Those stakeholders deal with us in terms of support councils, other advisory groups -- both on limited scales and regions -- as well as on a statewide basis. I think that does a lot of things. One, it helps focus our programs and make sure that we're working on the right things, the things that are important to the State of Ohio. But I think the other thing it does is that it really brings home to people on a local basis the presence of The Ohio State University. They recognize that we're dealing with the issues that they're dealing with and they have an opportunity to reach out to us on a very personal level. So, I think that there are a number of things that we would really point to when we start looking at what OARDC actually is.

We think of the Wooster campus, as having a couple of different functions, and I'm speaking for Chris Igodan, director of ATI, as well as myself for OARDC. Yesterday, Chris very clearly pointed out the contributions that are being made in terms of the technical training of people who go back into our rural and agricultural communities. Within three to four months of graduation, there is 99 percent placement of those students. That is an outstanding statement about the regard in which their graduates are held, and it tells you that it really is providing a very critical function.

I think the other thing is that when you look at this location, and you look at OARDC, you're talking about something that is a tremendous extension of the fact that we have a great enterprise in Columbus. It is centrally located in the state and we have 19 outstanding colleges that work together to come to bring the University together. But with this location, you also have the opportunity to have the rural setting with the acreage necessary to do a lot of the kind of work that is necessary for us to address particularly rural problems as well as the rural-urban interface problems. So I think that it gives us a presence in the northeast part of the state, as well as with our branches in the rest of the state.

The other thing I would point out is that rightfully you pointed to my boss, Bobby Moser, but you should recognize that, on this campus, we have faculty that are really tenured in four different colleges out of the total colleges at the University. We have faculty that are not only in Food, Agricultural, and Environmental

OARDC PRESENTATION (contd)

Dr. Slack: (contd)

Sciences, but we have faculty that are in the College of Veterinary Sciences. President Jennings mentioned Linda Saif, an outstanding professor in the Food Animal Health Program, who is actually a member of the College of Veterinary Medicine. We have multiple colleges represented, along with the Colleges of Human Ecology and Biological Sciences.

I think the setting here not only allows us to support those different functions, but it gives us a unique opportunity to bring those faculty together. It allows them to work across interdisciplinary lines in such a way that we can focus on some big problems in a unique manner.

One of the things that we supplied you with earlier was an annual report, and many of the things that I would point out are focused on in that report. This is information that we want you to have and we want other people in the state -- that make decisions about our programs -- to have so they understand where our resources come from, how we spend those resources, and what the impact of those resources are.

As I've indicated, this particular location has a unique aspect about it. We can not only do very basic research like Linda Saif does, which makes use of extraordinary facilities in our Molecular Cellular Imaging Center that has both scanning and transmission electron microscopes. Many of you saw this yesterday. But we also can do the field activities that address growing aspects of the agricultural community.

For example, one of the areas that has been underserved for many years has been the organic farming community. We have dedicated 40 acres of land strictly to trying to develop science-based information that underpins the directions that those programs are going. Much of that information that is relied upon in that particular community is word-of-mouth information -- it's not replicated, trialed information. That is the kind of thing that we're trying to provide, and we try to work across a lot of different groups in order to get that information together.

So we can work all the way from a very applied setting to a very basic setting. In fact, in many cases, on the large issues that we deal with, we can put interdisciplinary teams together so that we can address some of these larger areas.

One of the things that is unique about those -- and it is something that we've tried to stress in our programs in recent years -- is the fact that when we look at a problem it's not simply a production problem. Yes, we have excellence in our scientific faculty in terms of production agriculture, but it doesn't start and end with production agriculture. We have faculty who are outstanding in the environmental sciences. You cannot separate agriculture and the environment -- they go hand-in-hand. Oftentimes we tend to try and put things in boxes, they don't operate very well that way.

Another component that should be very obvious, but sometimes gets left out of the equation, is the social component. Many times we can come up with excellent ideas, programs, and ways to answer problems with very good technical solutions, but in fact if they're not socially acceptable, they don't go very far. We have to have people on our interdisciplinary teams who represent that part of the component.

OARDC PRESENTATION (contd)

Dr. Slack: (contd)

Finally, and certainly not last, they have to make economic sense. Very few things really go very far in this world unless they make economic sense. So we have to take these four areas and mold them together. Again, we have a unique opportunity for doing that.

I'd like to point out that even though we're about 90 miles removed from the Columbus campus, there's a tremendous amount of education that goes on up here. ATI has an enrollment of about 1,000 students. In addition, OARDC has about 80 graduate students pursuing masters and Ph.D. degrees at this location. So, we do a fair amount of graduate training as well.

I would indicate that when you look at the size of the campus, we are talking about 4,000 acres, which is pretty much evenly divided between ATI and OARDC. It sounds like a lot of acreage, but when you start looking at the animal agriculture, both in terms of the training as well as the research programs, that acreage gets utilized in multiple ways. We certainly recognize that we're blessed with the land, but we also feel that we really return to the state multiple times on the use of that land through the various agricultural enterprises that we have.

I might indicate that for OARDC, we have 75 faculty located on a full-time basis on this campus and we have about 450 people total that are employed. ATI has approximately 40 faculty and employees another 150 people. So it is not a small enterprise and you can see that by the infrastructure that is supported up here.

In terms of some programmatic things, I really would like to point out a few items. As I mentioned earlier, stakeholders are a very important part of our enterprise. We have really focused, particularly with the hires that we've made in the last decade, on bringing in people that are entrepreneurial, that can work well with other people, and they're very competitive for extramural grants. In the last five years, we've doubled the extramural granting activity of OARDC. We've become exceedingly competitive, particularly for federal extramural dollars and we see that trajectory continuing to go up.

At the same time, we've tried to set aside dollars for competitive programs that allow us to deal with a lot of the infrastructure in the state – different commodity groups and so forth. We can do matching grant programs that they can put money in. They know we're putting money in, and with these proposals they know what they're investing in. This has increased the amount of investment that we see. It's also increased the reaction and buy-in to what we're doing. It's a good way to do business.

I would indicate also that federally there is a very recent national competitive program that has been instituted called, "Future Agriculture and Food Systems." It has been in place for about two years. There is \$120 million available of competitive funding for that each year. In those two years of funding, we've had 12 projects funded and \$12 million worth of projects funded. So when I say that we do have excellence in our faculty – yes, we do. We have the ability to put interdisciplinary teams together, which is inherent in that program. It's a strength that we have and we can show that on a national level through the kinds of competitions that we're involved in.

I would also point out that over the last four years our faculty have become quite active in terms of licensing of technology. In that time period, 40 percent of the invention disclosures and licenses have actually come through OARDC-supported faculty. We have technologies that are licensed in that period, over 30 companies, and currently there are 25 patents that have been applied for.

OARDC PRESENTATION (contd)

Dr. Slack: (contd)

So we recognize the things that Dr. Jennings was pointing out. It is very critical that when we talk about excellence that we're having an impact beyond our boundaries and there are different measures that we can use. Clearly one of those strong measures is how we're valued by others and the utility of things that we do. I think that is a real hallmark of what we do.

In closing, I would like to point out in the materials that you have you'll notice that there is an insert called, "Seeds." One of the things that we've tried to do to bring these points more closely to home -- for some of those programs that are hallmarks -- is we tried to put together, in very straightforward language, what is being done, where the source of funds are coming from, and what the impact of those funds are.

For those of you last night that had an opportunity to participate in the cookout, if you ate any of the beef it was provided from one of our local businesses and it was certified Angus Beef. The caterer utilized their source of beef for Bueller's, which was the source of the beef. What I would point out is that they have supported some of the activities that you have, the title of it is, "Genetic and Nutritional Factors Affecting Muscle Characteristics in Carcass Value of Beef Cattle." That is a fairly complicated title, but the reality of it is that genetically an animal has an opportunity to have different qualities in its meat characteristics. One of the tricks is defining early on what that genetic potential is so that you can essentially handle that animal for that final use.

In fact what these investigators have done -- Drs. Jackwood and Fluharty, who do represent faculty in two different colleges working together -- is using a molecular marker, they have identified tenderness characteristics in a very young animal. The impact of that is that you can essentially determine what beef will be made into hamburger early on. This makes for a very focused -- in terms of programming and efficiency -- use of economy. This is going to have not only an impact in the State of Ohio, but will have a national impact. Genetic markers are literally worth millions of dollars. We're simply on the front end of that at this point.

Again, I would like to thank all of you for coming and allowing us to share a little bit of time ourselves with you. You're welcome back any time, and it has been our privilege and pleasure. Thank you.

Mr. Patterson:

Thank you, Steve. Are there any questions or comments for Steve? If not, thank you very much for being our host. We look forward to meeting with some of the faculty and community representatives from Wooster, who have been involved with OARDC, at lunch.

--0--

CONSENT AGENDA

President Edward H. Jennings:

We have 17 resolutions on the Consent Agenda today, but I would like to ask that number 17, the FY 2002-03 Current Funds Budget, be considered separately. Unless there are any objections, I would like to recommend the following 16 resolutions to the Board:

REGIONAL CAMPUS BOARD APPOINTMENTS

Resolution No. 2003-1

Synopsis: Approval of appointments to The Ohio State University Regional Campus Boards is proposed.

WHEREAS the Board of Trustees in 1994 approved the establishment of The Ohio State University Regional Campus Boards; and

WHEREAS it has been previously stipulated that "the board shall be composed of eleven members appointed by The Ohio State University Board of Trustees in consultation with the president of the university" (one member of the board shall be a member of the university board of trustees; nine members shall be private citizens; and one member shall be a student); and

WHEREAS the following named persons have been nominated and selected for appointments to the following Regional Campus Boards for the terms as specified:

Lima Board Appointments

Ted Griffith, 3-year term
Nancy J. Knight, 3-year term
James W. Unverferth, 3-year term

Newark Board Appointment

Robert Coffman, 2-year term

NOW THEREFORE

BE IT RESOLVED, That the foregoing nominees be approved as members of The Ohio State University-Lima Board and Newark Board, effective July 1, 2002.

AMENDMENTS TO THE RULES OF THE UNIVERSITY FACULTY

Resolution No. 2003-2

Synopsis: Approval of the following amendments to the *Rules of the University Faculty* are recommended.

WHEREAS the University Senate pursuant to rule 3335-1-09 of the Administrative Code is authorized to recommend through the President to the Board of Trustees the adoption of amendments to the *Rules of the University Faculty* as approved by the University Senate; and

WHEREAS the proposed changes in the *Rules of the University Faculty* were approved by the University Senate on June 5, 2002:

Amended Rules

3335-5-19 Faculty.

As used in these rules the term "faculty" shall include persons appointed by the board of trustees with regular, regular clinical, auxiliary, and emeritus faculty titles on full- or part-time appointments, with or without salary.

AMENDMENTS TO THE RULES OF THE UNIVERSITY FACULTY (contd)

Amended Rules (contd)

(A) Unchanged.

(B) "Regular clinical faculty": ~~persons with the titles of professor of clinical (division, department or college), associate professor of clinical (division, department or college), assistant professor of clinical (division, department or college), and instructor of clinical (division, department or college), who serve on appointments totaling fifty per cent or more service to the university. Regular clinical faculty appointments are made only in the college of dentistry, the college of nursing, the college of optometry, the departments of veterinary clinical sciences and veterinary preventive medicine in the college of veterinary medicine, the divisions of pharmacy practice and pharmaceutical administration in the college of pharmacy, and the following departments in the college of medicine and public health: anesthesiology, emergency medicine, family medicine, internal medicine, neurology, obstetrics and gynecology, ophthalmology, orthopaedics, otolaryngology, pathology, pediatrics, physical medicine and rehabilitation, preventive medicine, psychiatry, radiology, and surgery. Regular clinical faculty serve under fixed term contracts and are not eligible for tenure. Regular clinical faculty appointments are described in Chapter 3335-48 of the Administrative Code.~~

~~The number of persons holding regular clinical faculty titles in each division, department or college authorized to make such appointments cannot be greater than forty per cent of the combined total of regular and regular clinical faculty in that division, department or college. Individuals appointed to the regular clinical faculty are limited to participating in governance at the division, departmental and college levels, but may not participate in promotion and tenure matters of regular faculty.~~

Balance Unchanged.

3335-5-482 The ~~library~~ council on libraries and information technology.

(A) Membership.

The ~~library~~ council on libraries and information technology shall consist of ~~fifteen~~ thirteen members.

(1) ~~Nine~~ Seven regular faculty selected by the faculty council. The term of service is three years.

(2) ~~Four~~ Three students.

(a) and (b) unchanged.

(c) ~~Two~~ One undergraduate ~~students~~ student selected by the undergraduate student government. The term of service is one year.

(3) ~~Two~~ Three administrators (or their designees).

(a) and (b) unchanged.

(c) The chief information officer.

(B) Duties and responsibilities.

(1) ~~Formulate, in cooperation~~ In collaboration with the director of libraries and the chief information officer, the to formulate policies governing the ~~operation of the university~~

AMENDMENTS TO THE RULES OF THE UNIVERSITY FACULTY (contd)

Amended Rules (contd)

educational and research activities and services of libraries as an educational and research facility and information technology.

- (2) Assist the director of libraries and the chief information officer in the interpretation of library and information technology services to the university community.
- (3) Assist in the presentation of major library and information technology needs to the university administration.
- (4) Advise the executive vice president and provost on the appointment of a the director of libraries or the chief information officer.

(C) Organization.

- (1) The chair shall be elected from among the voting members of the ~~library~~ council.
- (2) and (3) unchanged.

3335-5-4811 Fiscal committee.

(A) Membership.

The fiscal committee shall consist of ~~sixteen~~ twenty-one members.

- (1) ~~Eight~~ Nine regular faculty members.
 - (a) ~~Six~~ Eight regular faculty, at least one of whom is a department chair, and at least two of whom are members of the senate, selected by the faculty council. The term of service is three years.
 - (b) ~~Two~~ One regular faculty appointed by the president. The term of service is three years.
- (2) Unchanged.
- (3) ~~Two~~ Three staff members appointed ~~by the president~~ for three-year terms.
 - (a) Two department-, school-, center- or college-level staff members with extensive fiscal and budgetary experience and expertise, one selected by the faculty council in consultation with the university staff advisory committee, and one selected by the executive deans in consultation with the senior fiscal officers.
 - (b) One staff member appointed by the president.
- (4) ~~Two~~ Five administrators.
 - (a) Two central administration officials appointed by the president. These members are non-voting.
 - (b) The three executive deans.

(B) Duties and responsibilities.

The committee shall have full access to all fiscal documentation necessary to perform the following functions:

AMENDMENTS TO THE RULES OF THE UNIVERSITY FACULTY (contd)

Amended Rules (contd)

- (1) Review, on a continuing basis, the fiscal policies and resources of the university;
- (2) and (3) unchanged.
- (4) Advise the president, in the event of an imminent financial crisis, whether a determination of financial exigency is warranted; and
- (5) Report annually to the faculty council and the senate on the budgetary and fiscal condition of the university.

(C) Organization.

- (1) The committee shall annually elect a chair shall be elected from among the voting members of the committee its regular faculty membership.
- (2) Unchanged.

Chapter 3335-47

Additional rules of the university faculty
concerning tenure-track faculty appointments, reappointments, promotion
and tenure

3335-47-02 Criteria for appointment, reappointment, and promotion and tenure of tenure-track faculty.

(A) through (D) unchanged.

- (E) Each tenure initiating unit shall have an appointments, promotion, and tenure document. The document shall describe, in qualitative terms, the unit's criteria for appointments, promotion, and tenure and evidence to be provided to support a case within the context of the unit's mission and the standards set forth in this rule as well as the mission and standards of the college. The document should indicate with some specificity how the quality and effectiveness of teaching, the quality and significance of scholarship, and the quality and effectiveness of service are to be documented and assessed. The document of a tenure initiating unit with regional campus faculty must establish criteria for appointments, promotion, and tenure for these faculty within the context of the regional campuses' mission as well as that of the tenure initiating unit. The document shall also describe the unit's procedures for conducting annual performance reviews of probationary faculty and reviews for promotion and tenure.

The document must be drawn up or amended through broad faculty consultation with all voting members of the tenure initiating unit according to the principles articulated in paragraphs (C)(2) and (D) of rule 3335-3-35 of the Administrative Code and must be approved by the dean of the college and the executive vice president and provost. ~~An academic unit that believes there is a reason for the unit to have policies and procedures differing from those set forth in this chapter may petition the office of academic affairs through the dean of the college and must set forth a rationale for why approval of the request is in the best interests of the unit and of the university. The office of academic affairs will consult with the rules committee or its designee in considering such petitions.~~

Balance unchanged.

3335-47-03 Probationary service, and duration of appointments for ~~regular~~ tenure-track faculty.

Balance unchanged.

AMENDMENTS TO THE RULES OF THE UNIVERSITY FACULTY (contd)

Amended Rules (contd)

3335-47-04 Promotion and tenure review procedures for tenure-track faculty.

Balance unchanged.

3335-47-05 Criteria and procedures for appeals of negative promotion and tenure decisions and appointment nonrenewals and for seventh year reviews for tenure-track faculty.

Balance unchanged.

3335-47-06 Tenure initiating unit.

(A) A tenure initiating unit is a division, department, school, or college approved by the council on academic affairs, the university senate, and the board of trustees. A tenure initiating unit has the following responsibilities for all faculty members assigned to it: to assist in professional development; to evaluate; to maintain official personnel records; and to initiate promotion, tenure, reappointment, and nonrenewal recommendations. The office of academic affairs shall be responsible for maintaining the official list of tenure initiating units.

(B) A single division, department, school, or college must serve as the tenure initiating unit for each regular tenure-track faculty member, including individuals with multiple appointments. Multiple appointments to the regular tenure-track faculty totaling fifty per cent or more of service to the university shall be considered to be the same as a single appointment of fifty per cent or more for the purpose of determining eligibility for tenure.

Balance unchanged.

3335-47-09 ~~Regular clinical faculty ranks~~ Exceptions.

~~The titles of regular clinical faculty are professor of clinical (division, department or college), associate professor of clinical (division, department or college), assistant professor of clinical (division, department or college), and instructor of clinical (division, department or college). Individuals in this track may have a full range of responsibilities to appropriate academic units with emphasis on patient care and clinical teaching activities. Clinical activities for faculty members in this category are to be included in approved practice plans. Any unit which believes that there is a reason for it to have policies and procedures differing from those set out in this chapter may request an exception. The request must be approved by the procedures established in the unit's pattern of administration and by the dean of the college, after broad and meaningful consultation with the unit's tenure-track faculty. The request will then be submitted to the executive vice president and provost and, if approved, to the university senate for approval.~~

~~(A) Appointment criteria.~~

~~Initial appointments, or transfer, to the regular clinical faculty will be made for individuals with the following experience or credentials:~~

- ~~(1) They are strict or geographic full-time faculty members in academic units authorized to make regular clinical faculty appointments (see paragraph (B) of rule 3335-5-19 of the Administrative Code).~~
- ~~(2) They engage in activities which consist primarily of patient care and clinical teaching and supervision.~~
- ~~(3) They have the appropriate educational background and credentials to engage in the activities outlined in paragraph (A)(2) of this rule. Formal requisite: D.D.S.,~~

AMENDMENTS TO THE RULES OF THE UNIVERSITY FACULTY (contd)

Amended Rules (contd)

~~D.V.M., M.D., Pharm. D., D.N.S., R.N., or Ph.D., R.N., or Ed.D., R.N., or O.D. degree or equivalent qualification.~~

- ~~(4) They are essential to the continuing mission of the relevant college as determined by the appropriate clinical division or department chair, dean of the college, and executive vice president and provost.~~

~~(B) Term of appointment.~~

- ~~(1) The initial appointment of a person to a regular clinical faculty position is probationary in nature. Probationary appointments are for a one-year period, and faculty members on such appointments shall be reviewed annually. The university does not assume any continuing obligation to renew the appointment of a regular clinical faculty member during the probationary period. Nonrenewal may be based upon such factors as an assessment of inadequate performance or insufficient development, or on any one of a number of academic, financial, or policy reasons, but must be the result of formal annual review in accord with review procedures established by the appropriate academic unit of the appointee in accord with paragraph (B)(3) of rule 3335-3-35 of the Administrative Code. The nonrenewal of an appointment in and of itself, however, should not carry with it the implication of either incompetence or misconduct on the part of the faculty member.~~
- ~~(2) During the fourth year of the initial appointment, a formal review will be conducted. The faculty member will be informed if the appointment is to be renewed for an additional term of five years.~~
- ~~(3) If subsequent appointments are made, they will be made for periods of five years. A formal review will be conducted in the fourth year of each five-year term and the faculty member will be informed if the appointment is to be renewed after the fifth year for another five-year term. Termination of employment during a five-year term, other than during the probationary period, shall be for reasons of cause or financial exigency and shall result from procedures established by faculty rules.~~
- ~~(4) All appointments will be based upon criteria established by the academic unit authorized to make regular clinical faculty appointments (see paragraph (B) of rule 3335-5-19 of the Administrative Code), approved by the dean of the college, and the executive vice president and provost.~~
- ~~(5) If the appointment is not renewed, standards of notice must be in accordance with rule 3335-47-08 of the Administrative Code.~~

~~(C) Transfers.~~

~~It is generally expected that the needs of the academic unit and the career goals of the prospective faculty member will result in meshing of need, expectation, responsibility, and expertise to allow a long-term appointment to either the regular faculty or regular clinical faculty. Should a transfer be considered appropriate, the following must be accomplished:~~

- ~~(1) The process of transfer from the regular faculty to the regular clinical faculty or from the regular clinical faculty to the regular faculty is initiated only upon the written request of the faculty member. A recommendation for transfer must indicate clear evidence of a change in the individual's career goals and expectations, duties, and activities.~~
- ~~(2) An individual appointed to a tenure-eligible position as an instructor or assistant professor requesting transfer to the regular clinical faculty must do so no later than the beginning of the fourth year of service or after tenure has been granted. Transfer of a~~

AMENDMENTS TO THE RULES OF THE UNIVERSITY FACULTY (contd)

Amended Rules (contd)

~~tenured faculty member to the regular clinical faculty requires resignation of the tenured position.~~

~~An individual from outside the university appointed to a tenure-eligible position as an associate professor requesting transfer to the regular clinical faculty must do so no later than the beginning of the second year of service, or after tenure has been granted.~~

- ~~(3) An individual appointed to the regular clinical faculty at the instructor, assistant professor, or associate professor level, upon transfer to a tenure-eligible position, must meet the criteria for the granting of tenure within the established time limits including that time already served in the regular clinical faculty appointment. Transfer at the professor level can be made only with concurrent granting of tenure.~~
- ~~(4) All transfers must be approved by the department appointments, promotions and tenure committee (or college if no departments exist), the division or department chair, the dean of the college, and the executive vice president and provost.~~
- ~~(5) Only one transfer to or from the regular clinical faculty will be approved during an individual's period of employment at the Ohio state university.~~

~~(D) Promotions:~~

~~Nominations for promotion originate in the department (or college if no departments exist) in accordance with criteria and procedures established by departmental (or college) faculty.~~

- ~~(1) A department or college may recommend the promotion of an instructor of clinical (division, department or college) to the rank of an assistant professor of clinical (division, department or college) or the promotion of an assistant professor of clinical (division, department or college) to the rank of associate professor of clinical (division, department or college) at any time up to the end of the ninth year. An individual who is not promoted by the end of nine years will be reviewed by the chair or dean and the appointments, promotions and tenure committee of the department or college to determine if continued employment is warranted. All recommendations will be reviewed by the appointments, promotions and tenure committee of the department, the college, and the office of academic affairs.~~
- ~~(2) A department or college may recommend the promotion of an associate professor of clinical (division, department or college) to professor of clinical (division, department or college) in recognition of outstanding accomplishments. Promotion may be recommended no earlier than the third year of service as an associate professor of clinical (division, department or college). All recommendations will be reviewed by the appointments, promotions and tenure committee of the department, the college, and the office of academic affairs. (B/T 10/5/84, B/T 5/4/89, B/T 7/6/90, B/T 11/2/90, B/T 3/6/92, B/T 4/8/94, B/T 5/3/96, B/T 4/4/97, B/T 12/4/98, B/T 7/12/2002)~~

New Chapter

Chapter 3335-48

Additional rules of the university faculty concerning regular clinical track faculty appointment, reappointment and nonreappointment, and promotion.

AMENDMENTS TO THE RULES OF THE UNIVERSITY FACULTY (contd)

Amended Rules (contd)

3335-48-01 Definition.

Regular clinical track faculty appointments are fixed term contract appointments that do not entail tenure. Regular clinical track faculty are teacher/practitioners and shall be engaged primarily in teaching activities related to: a) courses or instructional situations involving live patients or live clients, b) courses or instructional situations involving the simulation of live patients or live clients, or c) courses or instructional situations involving professional skills.

3335-48-02 Titles.

The term "regular clinical track faculty" will exist solely for the purpose of recording this type of appointment in the university's employment system data base. Individual colleges, schools, and departments with regular clinical track faculty may provide them with faculty rank titles that are distinct from tenure-track titles and are descriptive of the functions regular clinical track faculty perform in that college. Examples include, but are not limited to, professor of clinical (name of college, school, or department) and associate professor of professional practice.

3335-48-03 Appointment cap.

Unless an exception is approved by the university senate and the board of trustees, regular clinical faculty may comprise no more than forty per cent of the total regular faculty (as defined in rule 3335-5-19 of the Administrative Code) in each of the departments, schools, and colleges of the health sciences and no more than twenty per cent of the tenure-track faculty in other departments, schools, and colleges.

3335-48-04 Proposals and approval process.

(A) Proposals to establish or amend a regular clinical faculty track in a college must be submitted to the provost by the dean of the college. Proposals must include a clear rationale for establishing a regular clinical faculty track and address how the terms and conditions of the appointments will be consistent with the rules set forth in Chapter 3335-48, what titles will be given to regular clinical track faculty, and what department and college governance rights will be extended to regular clinical track faculty. Regular clinical faculty may not participate in the promotion and tenure reviews of tenure-track faculty. In addition, proposals must include the following components:

- (1) A definition of the role in teaching and scope of professional practice duties of clinical faculty, identifying specifically how those differ from duties of tenure-track faculty;
- (2) Identification of the requirements for a clinical faculty appointment, including appropriate terminal degrees and any credential or licensure requirements; and
- (3) A list of courses that could be taught by clinical faculty and the relationship of those courses to the general curriculum. The expectation would be that clinical faculty should teach primarily courses involving professional practice in the clinical setting or courses designed to teach professional skills.

Proposals must comply with any additional guidelines promulgated by the council on academic affairs and will be reviewed according to criteria specified by the council on academic affairs.

(B) College proposals to establish or amend a regular clinical faculty track must be approved by a majority of the tenure-track faculty of the college proposing to have a regular clinical faculty track, by the dean of the college, by the executive vice president and provost, by the university senate, and by the board of trustees. The executive vice president and

AMENDMENTS TO THE RULES OF THE UNIVERSITY FACULTY (contd)

Amended Rules (contd)

provost will transmit all proposals to the council on academic affairs, which will review proposals and make a recommendation to the university senate.

3335-48-05 Criteria for appointment, for reappointment and nonreappointment, and for promotion.

Regular clinical faculty may be appointed by colleges that do not have schools or departments and by schools and departments in colleges that have such subunits. The criteria for appointment, for reappointment and nonreappointment, and for promotion for regular clinical track faculty shall be established by the college, school, or department making such appointments and shall be set forth in that unit's appointments, promotion, and tenure document. The criteria must be consistent with the rationale for having a regular clinical faculty track in the unit in question and must be distinct from the criteria for tenure-track faculty appointments. However, normally regular clinical track faculty will have an earned doctorate or other terminal degree in the relevant field or equivalent experience. The criteria for appointment, for reappointment and nonreappointment, and for promotion should reflect the importance of the responsibilities of regular clinical track faculty.

3335-48-06 Procedures for appointment.

Procedures for appointment of regular clinical track faculty shall be established by the college, school, or department making such appointments and shall be set forth in that unit's appointments, promotion, and tenure document. Appointments at the rank of associate professor or professor require prior approval of the office of academic affairs.

3335-48-07 Term of appointment.

- (A) Contracts must be for a period of at least three years and for no more than five years.
- (B) The initial contract is probationary and a faculty member will be informed by the end of each probationary year as to whether he or she will be reappointed for the following year. By the end of the second to final year of the probationary contract, the faculty member will be informed as to whether a new contract will be extended at the conclusion of the probationary contract period. In the event that a new contract is not extended, the final year of the probationary contract is the terminal year of employment. There is no presumption that a new contract will be extended. In addition, the terms of a contract may be renegotiated at the time of reappointment.
- (C) During and until the end of the second and subsequent contract periods, regular clinical faculty appointments may only be terminated for cause (see rule 3335-5-04 of the Administrative Code) or financial exigency (see faculty rule 3335-5-021 of the Administrative Code) and the termination decision for either of these reasons shall result from procedures established by faculty rules. In addition, a contract may be renegotiated during a contract period only with the voluntary consent of the faculty member. By the end of the second to final year of each contract period, the faculty member will be informed as to whether a new contract will be extended at the conclusion of the current contract period. If a new contract is not extended, the final year of the current contract is a terminal year of employment. There is no presumption that a new contract will be extended. In addition, the terms of a contract may be renegotiated at the time of reappointment.
- (D) The standards of notice set forth in rule 3335-47-08 of the Administrative Code apply to regular clinical faculty track appointments.

AMENDMENTS TO THE RULES OF THE UNIVERSITY FACULTY (contd)

Amended Rules (contd)

3335-48-08 Annual review, reappointment/nonreappointment, and promotion review procedures.

The procedures for reviewing regular clinical track faculty annually and for reappointment/nonreappointment and promotion shall be set forth in the relevant college, school or department appointments, promotion, and tenure document and shall be consistent with review procedures established for tenure-track faculty, including those set forth in rules 3335-47-03 and 3335-47-04 of the Administrative Code with the following exceptions:

(A) The college dean's decision shall be final with respect to reappointment and nonreappointment and with respect to denial of promotion; and

(B) External evaluations are optional.

3335-48-09 Transfers from the tenure-track to the regular clinical track.

A college, school, or department may provide for the possibility of transfers from the tenure faculty track to the regular clinical faculty track if appropriate to its circumstances. A unit that permits transfers must abide by the following:

(A) The request for transfer must be initiated by the faculty member in writing and must state clearly how the individual's career goals and activities have changed;

(B) When a tenured faculty member transfers to the regular clinical faculty track, tenure is lost; and

(C) All transfers must be approved by the school director or department chair, the college dean, and the executive vice president and provost.

3335-48-10 Transfers from the regular clinical faculty track to the tenure-track.

Transfers from the regular clinical faculty track to the tenure-track are not permitted. Regular clinical faculty may apply for tenure track positions and compete in regular national searches for such positions.

NOW THEREFORE

BE IT RESOLVED, That the foregoing amendments to the *Rules of the University Faculty* be adopted as recommended by the University Senate.

DEGREES AND CERTIFICATES – SUMMER QUARTER COMMENCEMENT

Resolution No. 2003-3

Synopsis: Approval of Degrees and Certificates for Summer Quarter is proposed.

WHEREAS pursuant to paragraph (E) of rule 3335-1-06 of the Administrative Code, the Board has authority for the issuance of degrees and certificates; and

WHEREAS the faculties of the colleges and schools shall transmit, in accordance with rule 3335-9-29 of the Administrative Code, for approval by the Board of Trustees the names of persons who have completed degree and certificate requirements:

DEGREES AND CERTIFICATES – SUMMER QUARTER COMMENCEMENT (contd)

NOW THEREFORE

BE IT RESOLVED, That the degrees and certificates be conferred on August 30, 2002, to those persons who have completed the requirements for their respective degrees and certificates and are recommended by the colleges and schools, and that the names of those persons awarded degrees and certificates be included in the minutes of this meeting.

PERSONNEL ACTIONS

Resolution No. 2003-4

BE IT RESOLVED, That the personnel actions as recorded in the Personnel Budget Records of the University since the June 7, 2002 meeting of the Board, including the following Appointment/Reappointments, Promotions, Appointments/Reappointments of Chairpersons/Director, Leaves of Absence Without Salary, Professional Improvement Leaves, Promotions/Tenure/Reappointments, Emeritus Titles, and salary rolls with promotion, as detailed in the University Budget be approved.

Appointment

Name: RONALD L. WHISLER
Title: Professor (The Martha Morehouse Chair in Arthritis and Immunology Research)
College: Medicine and Public Health
Term: August 1, 2002, through June 30, 2006

Reappointments

Name: RICHARD W. HALL
Title: Interim Dean
College: Biological Sciences
Term: July 1, 2002, through August 31, 2002

Name: LAWRENCE W. LIBBY
Title: Professor (The C. William Swank Chair in Rural and Urban Policy)
College: Food, Agricultural, and Environmental Sciences
Term: August 1, 2002, through July 31, 2007

Name: CARL R. ZULAUF
Title: Professor (The Francis B. McCormick Professorship in Agricultural Marketing and Policy)
College: Food, Agricultural, and Environmental Sciences
Term: July 1, 2002, through June 30, 2007

Promotions

Name: JUDITH B. FOUNTAIN
Title: Assistant Vice Provost for Women's Policy Initiatives
Office: Academic Affairs
Effective: July 1, 2002
Concurrent Appointment: Director, The Women's Place

PERSONNEL ACTIONS (contd)

Promotions (contd)

Name: THOMAS J. ROSOL
Title: Senior Associate Vice President
Office: Research
Effective: July 1, 2002
Present Position: Professor, Department of Veterinary Biosciences

Appointment of Chairpersons/Director

July 1, 2002, through July 31, 2002

School of Educational Policy and Leadership James W. Altschuld*

July 1, 2002, through June 30, 2006

Art Education Patricia L. Stuhr
History Kenneth J. Andrien

October 1, 2002, through September 30, 2006

Finance Anil K. Makhija

Reappointment of Chairpersons

July 1, 2002, through September 30, 2006

Mathematics Peter D. March

October 1, 2002, through September 30, 2006

Physics William F. Saam

*Interim

Leaves of Absence Without Salary

ILEANA RODRIGUEZ, Professor, Department of Spanish and Portuguese, effective Winter Quarter 2003, to accept a visiting professorship at Michigan State University.

ERIC O. FISHER, Associate Professor, Department of Economics, effective Autumn Quarter 2002, Winter Quarter and Spring Quarter 2003, to accept the AGIP Professor of International Economics at The Johns Hopkins University, School of Advanced International Studies, Bologna Center, Bologna, Italy.

JANE HATHAWAY, Associate Professor, Department of History, effective Winter Quarter 2003, to accept an appointment as Ertegun Visiting Associate Professor of Ottoman history in the Department of Near Eastern Studies at Princeton University.

Leave of Absence Without Salary--Continuation

JENNIFER C. TERRY, Associate Professor, Department of Comparative Studies, effective Autumn Quarter 2002, Winter Quarter and Spring Quarter 2003, to continue a visiting position in the Department of Women's Studies at the University of California at Berkeley.

PERSONNEL ACTIONS (contd)

Professional Improvement Leaves

JONATHAN P. PELZ, Professor, Department of Physics, effective Autumn Quarter 2002.

XIAOTONG SHEN, Associate Professor, Department of Statistics, effective Autumn Quarter 2002.

LAURA L. STAFFORD, Associate Professor, School of Journalism and Communication, effective Winter Quarter, Spring Quarter, and Autumn Quarter 2003.

Professional Improvement Leave—Cancellation

PATRICIA L. STUHR, Professor, Department of Art Education, effective Autumn Quarter 2002, Winter Quarter and Spring Quarter 2003.

Professional Improvement Leave—Change in Dates

MICHAEL L. BENEDICT, Professor, Department of History, change dates from Autumn Quarter 2002, Winter Quarter and Spring Quarter 2003, to Winter Quarter, Spring Quarter, and Autumn Quarter 2003.

Emeritus Titles

ROBERT C. MACCALLUM, Department of Psychology, with the title Professor Emeritus, effective October 1, 2002.

PEGGY S. SCHEAR, Ohio State University Extension, with the title Associate Professor Emeritus, effective July 1, 2002.

FELICISIMA C. SERAFICA, Department of Psychology, with the title Associate Professor Emeritus, effective August 1, 2002.

GORDON A. YOUNG, Department of Pediatrics, with the title Associate Professor Emeritus, effective July 1, 2002.

F. LEE ST. JOHN, Department of Evolution, Ecology, and Organismal Biology (Newark Campus), with the title Associate Professor Emeritus, effective July 1, 2002.

JUANITA E. MILLER, Ohio State University Extension, with the title Assistant Professor Emeritus, effective July 1, 2002.

ANN C. SMITH, Ohio State University Extension, with the title Assistant Professor Emeritus, effective July 1, 2002.

PERSONNEL ACTIONS (contd)

Promotions, Tenure, and Reappointments

COLLEGE OF THE ARTS

PROMOTION TO PROFESSOR

Susan B. Hadley, Dance - effective 10/1/2002
Antonio G. Mendoza, Art - effective 10/1/2002
Anne M. Morganstern, History of Art - effective 10/1/2002

PROMOTION TO ASSOCIATE PROFESSOR WITH TENURE

Todd J. DeVriese, Art, Marion - effective 10/1/2002
Robert J. D. Frego, School of Music - effective 10/1/2002
Daniel A. Gray, Theatre - effective 10/1/2002
Rebecca C. Harvey, Art - effective 10/1/2002
Thomas N. Koran, School of Music - effective 10/1/2002
Valarie W. Mockabee, Dance - effective 10/1/2002
Georgianna Short, Art Education - effective 10/1/2002
Steven M. Thurston, Art - effective 10/1/2002
Loretta R. Woliver, School of Music - effective 10/1/2002

COLLEGE OF BIOLOGICAL SCIENCES

PROMOTION TO PROFESSOR

Peter S. Curtis, Evolution, Ecology and Organismal Biology - effective 10/1/2002
Norman F. Johnson, Entomology - effective 10/1/2002
Joseph A. Krzycki, Microbiology - effective 10/1/2002

PROMOTION TO ASSOCIATE PROFESSOR WITH TENURE

Maria A. Gilles-Gonzalez, Biochemistry - effective 10/1/2002
Parwinder Grewal, Entomology/OARDC - effective 7/1/2002
Daniel A. Herms, Entomology/OARDC - effective 7/1/2002
Johannes S. Klompen, Entomology - effective 10/1/2002
Hay-Oak Park, Molecular Genetics - effective 10/1/2002
Mark A. Seeger, Molecular Genetics - effective 10/1/2002
Joseph B. Williams, Evolution, Ecology and Organismal Biology - effective 10/1/2002

TENURE

Biao Ding, Plant Biology - effective 10/1/2002

MAX M. FISHER COLLEGE OF BUSINESS

PROMOTION TO ASSOCIATE PROFESSOR WITH TENURE

Bernadette A. Minton, Finance - effective 10/1/2002
Jeffrey J. Reuer, Management and Human Resources - effective 10/1/2002

COLLEGE OF DENTISTRY

PROMOTION TO PROFESSOR

Phillip T. Marucha - effective 7/1/2002
Robert R. Seghi - effective 7/1/2002

COLLEGE OF DENTISTRY
REGULAR CLINICAL

PROMOTION TO PROFESSOR-CLINICAL AND REAPPOINTMENT

Joel I. Haring - effective 7/1/2002 and 7/1/2003

PERSONNEL ACTIONS (contd)

Promotions, Tenure, and Reappointments (contd)

COLLEGE OF DENTISTRY
REGULAR CLINICAL (contd)

REAPPOINTMENT

John R. Kalmar - effective 7/1/2003

Constance R. Kuntupis - effective 7/1/2003

COLLEGE OF EDUCATION

PROMOTION TO PROFESSOR

Donna L. Pastore, School of Teaching and Learning - effective 10/1/2002

Vladimir M. Sloutsky, School of Teaching and Learning - effective 10/1/2002

PROMOTION TO ASSOCIATE PROFESSOR WITH TENURE

Janet Buckworth, School of Teaching and Learning - effective 10/1/2002

Patricia E. Enciso, School of Teaching and Learning - effective 10/1/2002

Nancy A. Neef, School of Teaching and Learning - effective 10/1/2002

Phillip C. Ward, School of Teaching and Learning - effective 10/1/2002

Ian A. G. Wilkinson, School of Teaching and Learning - effective 10/1/2002

COLLEGE OF ENGINEERING

PROMOTION TO PROFESSOR

Anish K. Arora, Computer and Information Science - effective 10/1/2002

Roberto G. Rojas-Teran, Electrical Engineering - effective 10/1/2002

Yann G. Guezennec, Mechanical Engineering - effective 10/1/2002

PROMOTION TO ASSOCIATE PROFESSOR WITH TENURE

Shahrukh A. Irani, Industrial, Welding and Systems Engineering - effective 10/1/2002

Anthony F. Luscher, Mechanical Engineering - effective 10/1/2002

Nadine B. Sarter, Industrial, Welding and Systems Engineering - effective 10/1/2002

Harold W. Walker, Civil and Environmental Engineering & Geodetic Science - effective 10/1/2002

Yunzhi Wang, Materials Science and Engineering - effective 10/1/2002

COLLEGE OF FOOD, AGRICULTURAL, AND ENVIRONMENTAL SCIENCES

PROMOTION TO PROFESSOR

Harold M. Keener, Food, Agricultural and Biological Engineering - effective 7/1/2002

David S. Kraybill, Agricultural, Environmental and Development Economics - effective 7/1/2002

Stephen G. P. Nameth, Plant Pathology - effective 7/1/2002

Ahmed E. Yousef, Food Science and Technology - effective 7/1/2002

PROMOTION TO ASSOCIATE PROFESSOR WITH TENURE

Douglas J. Doohan, Horticulture and Crop Science - effective 7/1/2002

Robert J. Gates, School of Natural Resources - effective 7/1/2002

Sophien Kamoun, Plant Pathology - effective 7/1/2002

OHIO STATE EXTENSION

PROMOTION TO ASSOCIATE PROFESSOR WITH TENURE

Diane E. Johnson - effective 7/1/2002

Yu Gao - effective 7/1/2002

Edwin M. Lentz - effective 7/1/2002

PERSONNEL ACTIONS (contd)

Promotions, Tenure, and Reappointments (contd)

OHIO STATE EXTENSION (contd)

PROMOTION TO ASSOCIATE PROFESSOR

James A. Chatfield - effective 7/1/2002

Steve D. Ruhl - effective 7/1/2002

Deanna L. Tribe - effective 7/1/2002

PROMOTION TO ASSISTANT PROFESSOR WITH TENURE

Erik A. Draper - effective 7/1/2002

Nancy G. Stehulak - effective 7/1/2002

Marisa B. Warrix - effective 7/1/2002

Gregory M. Yost - effective 7/1/2002

COLLEGE OF HUMANITIES

PROMOTION TO PROFESSOR

Robert W. Batterman, Philosophy - effective 10/1/2002

Kathy M. Fagan, English - effective 10/1/2002

Helen Fehervary, Germanic Languages and Literatures - effective 10/1/2002

Leigh Gilmore, English - effective 10/1/2002

John F. Guilmartin, Jr., History - effective 10/1/2002

Glenn A. Hartz, Philosophy, Mansfield - effective 10/1/2002

Donald C. Hubin, Philosophy - effective 10/1/2002

Keith Johnson, Linguistics - effective 10/1/2002

Nancy J. Johnson, English - effective 10/1/2002

Peter O. King, Philosophy - effective 10/1/2002

Claire C. Robertson, History - effective 10/1/2002

Allan J. Silverman, Philosophy - effective 10/1/2002

PROMOTION TO ASSOCIATE PROFESSOR WITH TENURE

Ignacio Corona, Spanish & Portuguese - effective 10/1/2002

Mary M. Fonow, Women's Studies - effective 10/1/2002

PROMOTION TO ASSOCIATE PROFESSOR WITH TENURE (contd)

Chan E. Park-Miller, East Asian Languages and Literatures - effective 10/1/2002

Dorothy P. Noyes, English - effective 10/1/2002

Roxann Wheeler, English - effective 10/1/2002

Victoria J. Wohl, Greek and Latin - effective 10/1/2002

COLLEGE OF HUMAN ECOLOGY

PROMOTION TO ASSOCIATE PROFESSOR WITH TENURE

Michael J. Glassman, Human Development & Family Science - effective 10/1/2002

COLLEGE OF LAW

PROMOTION TO PROFESSOR

Sharon L. Davies – effective 8/16/2002

Katherine H. Federle – effective 8/16/2002

Alan C. Michaels – effective 8/16/2002

LIBRARIES

PROMOTION TO PROFESSOR

Carol P. Diedrichs - effective 7/1/2002

James Murphy - effective 7/1/2002

PERSONNEL ACTIONS (contd)

Promotions, Tenure, and Reappointments (contd)

LIBRARIES (contd)

PROMOTION TO ASSOCIATE PROFESSOR WITH TENURE

Guoqing Li - effective 7/1/2002

PROMOTION TO ASSOCIATE PROFESSOR

Alan A. Green - effective 7/1/2002

TENURE

Tschera Connell - effective 7/1/2002

COLLEGE OF MATHEMATICAL AND PHYSICAL SCIENCES

PROMOTION TO PROFESSOR

Jeffrey J. Daniels, Geological Sciences - effective 10/1/2002

Darren L. Depoy, Astronomy - effective 10/1/2002

Samir D. Mathur, Physics - effective 10/1/2002

Andras Nemethi, Mathematics - effective 10/1/2002

Ralph R. Vonfrese, Geological Sciences - effective 10/1/2002

David H. Weinberg, Astronomy - effective 10/1/2002

PROMOTION TO ASSOCIATE PROFESSOR WITH TENURE

Motomu Ibaraki, Geological Sciences - effective 10/1/2002

Thomas Kerler, Mathematics - effective 10/1/2002

Todd L. Lowary, Chemistry - effective 10/1/2002

Omer Ozturk, Statistics, Marion - effective 10/1/2002

Jonathan R. Parquette, Chemistry - effective 10/1/2002

Douglass W. Schumacher, Physics - effective 10/1/2002

Fei-Ran Tian, Mathematics - effective 10/1/2002

Claudia Turro, Chemistry - effective 10/1/2002

COLLEGE OF MEDICINE AND PUBLIC HEALTH

PROMOTION TO PROFESSOR

Arthur H. M. Burghes, Molecular and Cellular Biochemistry - effective 10/1/2002

Jane D. Case-Smith, School of Allied Medical Professions - effective 7/1/2002

Charis Eng, Internal Medicine - effective 7/1/2002

William B. Farrar, Surgery - effective 7/1/2002

Jeffrey M. Fowler, Obstetrics and Gynecology - effective 7/1/2002

James W. Hoekstra, Family Medicine - effective 7/1/2002

Jeffrey A. Kuret, Molecular and Cellular Biochemistry - effective 10/1/2002

William P. Lafuse, Molecular Virology, Immunology and Medical Genetics - effective 10/1/2002

Christopher M. Walker, Pediatrics - effective 7/1/2002

PROMOTION TO ASSOCIATE PROFESSOR WITH TENURE

D. Michele Basso, School of Allied Medical Professions - effective 10/1/2002

William E. Carson III, Surgery - effective 7/1/2002

Kelly R. Clark, Pediatrics - effective 7/1/2002

Joan E. Durbin, Pediatrics - effective 7/1/2002

Phillip D. Hoberty, School of Allied Medical Professions - effective 7/1/2002

Steven E. Katz, Ophthalmology - effective 7/1/2002

Ronald P. Pelletier, Surgery - effective 7/1/2002

Christoph Plass, Molecular Virology, Immunology and Medical Genetics - effective 7/1/2002

Dara P. Schuster, Internal Medicine - effective 7/1/2002

Miguel A. Villalona, Internal Medicine - effective 7/1/2002

Gregory J. Wiet, Otolaryngology - effective 7/1/2002

PERSONNEL ACTIONS (contd)

Promotions, Tenure, and Reappointments (contd)

COLLEGE OF MEDICINE AND PUBLIC HEALTH (contd)

PROMOTION TO ASSOCIATE PROFESSOR [without tenure]

Thomas J. Sferra, Pediatrics - effective 7/1/2002

Lisa D. Yee, Surgery - effective 7/1/2002

COLLEGE OF MEDICINE AND PUBLIC HEALTH
REGULAR CLINICAL

PROMOTION TO PROFESSOR-CLINICAL AND REAPPOINTMENT

Mark W. Arnold, Surgery - effective 7/1/2002 and 7/1/2003

PROMOTION TO ASSOCIATE PROFESSOR-CLINICAL

James C. Tober, Surgery - effective 7/1/2002

PROMOTION TO ASSOCIATE PROFESSOR-CLINICAL AND REAPPOINTMENT

James L. Moore, Neurology - effective 7/1/2002 and 7/1/2003

Douglas W. Scharre, Neurology - effective 7/1/2002 and 7/1/2003

REAPPOINTMENT

William J. Barson, Pediatrics - effective 7/1/2003

Jennifer I. Chapman, Pediatrics - effective 7/1/2003

Elmahdi A. Elkhammas, Surgery - effective 7/1/2003

Lucy R. Freedy, Radiology - effective 7/1/2003

Stephen P. Hoffmann, Internal Medicine - effective 7/1/2003

Grant L. Jones, Orthopaedics - effective 7/1/2003

Christopher C. Kaeding, Orthopaedics - effective 7/1/2003

Sedigheh Keyhani-Rofagha, Pathology - effective 7/1/2003

Nadeem Khan, Pediatrics - effective 7/1/2003

Sorabh Khandelwal, Emergency Medicine - effective 7/1/2003

Kathryn J. Klopfenstein, Pediatrics - effective 7/1/2003

Susan L. Koletar, Internal Medicine - effective 7/1/2003

Cynthia G. Kreger, Internal Medicine - effective 7/1/2003

Mary R. Leder, Pediatrics - effective 7/1/2003

Kathryn E. Nuss, Pediatrics - effective 7/1/2003

Stephen F. Pariser, Psychiatry - effective 7/1/2003

Radu V. Saveanu, Psychiatry - effective 7/1/2003

Tara M. Smith, Pediatrics - effective 7/1/2003

Doris E. Walzak, Internal Medicine - effective 7/1/2003

COLLEGE OF NURSING

PROMOTION TO ASSOCIATE PROFESSOR WITH TENURE

Susan Frazier - effective 10/1/2002

COLLEGE OF NURSING
REGULAR CLINICAL

REAPPOINTMENT

Linda S. Daley - effective 7/1/2003

Mary M. Gottesman - effective 7/1/2002

PERSONNEL ACTIONS (contd)

Promotions, Tenure, and Reappointments (contd)

COLLEGE OF OPTOMETRY

PROMOTION TO PROFESSOR

Paulette P. Schmidt - effective 7/1/2002

Karla S. Zadnik - effective 7/1/2002

PROMOTION TO ASSOCIATE PROFESSOR WITH TENURE

Nicklaus F. Fogt - effective 7/1/2002

Marjean T. Kulp - effective 7/1/2002

REGULAR CLINICAL

PROMOTION TO ASSOCIATE PROFESSOR-CLINICAL

Michael J. Earley - effective 7/1/2002

COLLEGE OF PHARMACY

PROMOTION TO ASSOCIATE PROFESSOR WITH TENURE

Peter Swaan - effective 10/1/2002

Robert J. Lee - effective 10/1/2002

COLLEGE OF PHARMACY

REGULAR CLINICAL

REAPPOINTMENT

Kristin A. Casper - effective 7/1/2003

COLLEGE OF SOCIAL AND BEHAVIORAL SCIENCES

PROMOTION TO PROFESSOR

Jan Edwards, Speech and Hearing Science - effective 10/1/2002

Masao Ogaki, Economics - effective 10/1/2002

Caroline M. Palmer, Psychology - effective 10/1/2002

PROMOTION TO ASSOCIATE PROFESSOR WITH TENURE

Theodore G. Hopf, Political Science - effective 10/1/2002

Dean P. Lacy, Political Science - effective 10/1/2002

Alan T. Murray, Geography - effective 10/1/2002

Paul F. Robbins, Geography - effective 10/1/2002

Yongmin Sun, Sociology, Mansfield - effective 10/1/2002

TENURE

Jeffrey K. McKee, Anthropology - effective 10/1/2002

COLLEGE OF SOCIAL WORK

PROMOTION TO ASSOCIATE PROFESSOR WITH TENURE

Thomas Gregoire - effective 10/1/2002

Margaret E. Vonk - effective 10/1/2002

COLLEGE OF VETERINARY MEDICINE

PROMOTION TO PROFESSOR

Teresa Y. Morishita, Veterinary Preventive Medicine - effective 7/1/2002

Michael Podell, Veterinary Clinical Sciences - effective 7/1/2002

PERSONNEL ACTIONS (contd)

Promotions, Tenure, and Reappointments (contd)

COLLEGE OF VETERINARY MEDICINE (contd)

PROMOTION TO ASSOCIATE PROFESSOR WITH TENURE

Joanne Hardy, Veterinary Clinical Sciences - effective 7/1/2002

Andrew Hillier, Veterinary Clinical Sciences - effective 7/1/2002

REGULAR CLINICAL

PROMOTION TO ASSOCIATE PROFESSOR-CLINICAL AND REAPPOINTMENT

Shane W. Bateman, Veterinary Clinical Sciences - effective 7/1/2002 and 7/1/2003

REAPPOINTMENT

Richard W. Meiring, Veterinary Preventive Medicine - effective 7/1/2003

RESOLUTIONS IN MEMORIAM

Resolution No. 2003-5

Synopsis: Approval of Resolutions in Memoriam is proposed.

RESOLVED, That the Board adopt the following Resolutions in Memoriam and that the President be requested to convey a copy to the families of the deceased.

C. Earl Baylor

The Board of Trustees of The Ohio State University expresses its sorrow upon the death on June 5, 2002, of C. Earl Baylor, Associate Professor Emeritus in the Ohio State University Extension.

Mr. Baylor was born July 6, 1925, in Stockton, Illinois. He received a Bachelor of Science degree in agriculture from the University of Illinois in 1950. He also earned a Master's degree with a double major in extension education and dairy science from the University of Illinois in 1963.

Earl Baylor began his Extension career in Ohio in 1966, as the county agent for agriculture in Brown County. He held this position until his retirement in 1985. Throughout Mr. Baylor's career with Extension he was the county chair and also served on local committees. During his leadership, he was instrumental in leading the dairy farm management industry in Brown County to bring added income to those farmers. In addition, he worked with zoning programs and farmers who had production of cash tobacco as the chief source of agriculture income. He was a member of the Extension fraternity, Epsilon Sigma Phi, and participated in both state committees and meetings.

His contributions in providing excellent Extension educational programs during his career earned him the respect and admiration of co-workers and associates throughout the state.

On behalf of the University community, the Board of Trustees expresses to the family of Professor C. Earl Baylor its deepest sympathy and sense of understanding of their loss. It was directed that this resolution be inscribed upon the minutes of the Board of Trustees and that a copy be tendered to his family as an expression of the Board's heartfelt sympathy.

RESOLUTIONS IN MEMORIAM (contd)

Mario Iglesias

The Board of Trustees of The Ohio State University expresses its sorrow upon the death on May 16, 2002, of Mario Iglesias, Associate Professor Emeritus, in the Department of Spanish and Portuguese.

Professor Iglesias completed his undergraduate education in Havana, Cuba. He held a Master of Arts degree from Western Reserve University in Cleveland, Ohio, and a Ph.D. degree from the University of Havana.

Professor Iglesias began his teaching career at the Ruston Academy in Havana, his birthplace. In 1961, he and his family fled Cuba and immigrated to the United States. He joined the faculty of The Ohio State University in 1967, where for 28 years he taught Spanish language and Hispanic cultures and mentored hundreds of graduate teaching associates in methods of teaching Spanish at the college level. Many secondary school language teachers and their students also benefited from Professor Iglesias' support through his many outreach workshops.

Over the years, Professor Iglesias served as director of the Spanish Language Program, director of Spanish Individualized Instruction, and chair of Undergraduate Studies, in the Department of Romance Languages and later in the Department of Spanish and Portuguese. His dedication to undergraduate teaching was reflected in the textbooks and pedagogical articles that he published throughout his distinguished career.

Among his students and colleagues, Professor Iglesias was known for his integrity, his untiring efforts to promote the study of Spanish and Hispanic cultures, and for his lively sense of humor.

On behalf of the University community, the Board of Trustees expresses to the family of Professor Mario Iglesias its deepest sympathy and understanding of their loss. It was directed that this resolution be inscribed upon the minutes of the Board of Trustees and that a copy be tendered to his family as an expression of the Board's heartfelt sympathy.

George M. Lawrence

The Board of Trustees of The Ohio State University expresses its sorrow upon the death on May 18, 2002, of George M. Lawrence, Assistant Professor Emeritus in the Department of Electrical Engineering.

Professor Lawrence graduated from Oberlin College in 1930, and taught math and science at schools in Crestline, Norwalk, and Sandusky, Ohio, from the time of his graduation until 1946. He served as a lieutenant, USNR, 1944-1946, with duty in Pearl Harbor and other locations in the United States. After the war, he obtained the degree of Master of Science in Electrical Engineering from Ohio State, and began his career of service to OSU. He was an assistant professor in the Department of Electrical Engineering from 1949 to 1952. In 1952, he became an assistant dean in the College of Engineering, a position he held until his retirement in 1970.

Professor Lawrence's work at the College of Engineering primarily involved undergraduate students. As a former public school teacher, he knew the importance of helping students make the transition between high school and the university, and set in place several policies and practices to help make the process smoother. Always an advocate for the student, he truly believed in the value of higher education, and worked tirelessly to help create and maintain the quality of the academic offerings of the College of Engineering.

On behalf of the university community, the Board of Trustees expresses to the family of Professor George Lawrence its deepest sympathy and sense of understanding of their loss. It was directed that this resolution be inscribed upon the minutes of the Board of Trustees and that a copy be tendered to his family as an expression of the Board's heartfelt sympathy.

REPORT OF RESEARCH CONTRACTS AND GRANTS

Resolution No. 2003-6

Synopsis: The reports on research and other sponsored program contracts and grants and the summary for May 2002 are presented for Board acceptance.

WHEREAS monies are solicited and received on behalf of the University from governmental, industrial, and other agencies in support of research, instructional activities, and service; and

WHEREAS such monies are received through The Ohio State University Research Foundation:

NOW THEREFORE

BE IT RESOLVED, That the research agreement between The Ohio State University and The Ohio State University Research Foundation for the contracts and grants reported herein during the month of May 2002 be approved.

REPORT ON UNIVERSITY DEVELOPMENT

Resolution No. 2003-7

Synopsis: The report on the receipt of gifts and the summary for May 2002 are presented for Board acceptance.

WHEREAS monies are solicited and received on behalf of the University from alumni, industry, and various individuals in support of research, instructional activities, and service; and

WHEREAS such gifts are received through The Ohio State University Development Fund and The Ohio State University Foundation; and

WHEREAS this report includes the establishment of The Department of Pathology Professorship, The University Pathology Services Professorship, The Honorable William B. Saxbe Designated Professorship in Law, and The Howard E. LeFevre 1929 Fellowship; and

WHEREAS this report includes the establishment of fifteen (15) new named endowed funds and the amendment of seven (7) named endowed funds:

NOW THEREFORE

BE IT RESOLVED, That the acceptance of the report from The Ohio State University Development Fund and The Ohio State University Foundation during the month of May 2002 be approved.

REPORT ON UNIVERSITY DEVELOPMENT (contd)

TOTAL UNIVERSITY PRIVATE SUPPORT

July through May
2000-2001 Compared to 2001-2002

GIFT RECEIPTS BY DONOR TYPE

	Dollars July through May		
	<u>2000-2001</u>	<u>2001-2002</u>	<u>%Change</u>
Individuals:			
Alumni (Current Giving)	\$28,287,918	\$30,404,491	7
Alumni (From Bequests)	<u>6,659,028</u>	<u>5,382,380</u>	(19)
Alumni Total	\$34,946,946	\$35,786,871	2
Non-Alumni (Current Giving)	\$22,870,120	\$14,588,779	(36)
Non-Alumni (From Bequests)	<u>10,002,002</u>	<u>3,572,731</u>	(64)
Non-Alumni Total	\$32,872,122	\$18,161,510	(45)
Individual Total	\$67,819,068	\$53,948,381	(20) ^A
Corporations/Corp/Foundations	\$36,315,055	\$39,130,941	8 ^B
Private Foundations	\$14,545,406	\$18,838,877	30 ^C
Associations and Other Organizations	<u>\$4,032,186</u>	<u>\$4,417,380</u>	10 ^D
Total	\$122,711,715	\$116,335,579	(5)

NOTES

- A Individual giving at the \$10,000 or more level is down 19% for this year (\$50.0 million from 536 gifts last year; \$35.1 million from 498 gifts this year).
- B Corporate giving at the \$10,000 or more level is up 9% so far this year (\$29.1 million from 614 gifts last year; \$31.6 million from 641 gifts this year).
- C Foundation giving at the \$10,000 or more level is up 32% so far this year (\$13.6 million from 174 gifts last year; \$18.0 million from 187 gifts this year).
- D Other organizations and associations have given about \$100,000 more at the \$10,000 or more level so far this year compared with last year.

REPORT ON UNIVERSITY DEVELOPMENT (contd)

TOTAL UNIVERSITY PRIVATE SUPPORT (contd)

July from May
2000-2001 Compared to 2001-2002

GIFT RECEIPTS BY PURPOSE

	Dollars July through May		
	<u>2000-2001</u>	<u>2001-2002</u>	<u>% Change</u>
Gift Receipts to Current Use and Endowment Funds:			
Buildings/Equipment	\$17,399,361	\$19,369,448	11
Faculty Support	\$7,493,540	\$11,633,557	55
Program Support	\$75,856,235	\$64,336,265	(15)
Student Financial Aid	\$11,939,240	\$12,184,735	2
Annual Funds-Colleges/Departments	\$8,289,537	\$7,617,111	(8)
Annual Funds-University	<u>\$1,733,802</u>	<u>\$1,194,463</u>	(31)
Total	\$122,711,715	\$116,335,579	(5)

GIFT ADDITIONS TO ENDOWMENT

Dollars
July through May

<u>2000-2001</u>	<u>2001-2002</u>	<u>% Change</u>
29,437,105	\$35,469,956	20

REPORT ON UNIVERSITY DEVELOPMENT (contd)

THE OHIO STATE UNIVERSITY DEVELOPMENT FUND

	<u>Previous Gifts</u>	<u>Current Gifts</u>	<u>Total Gifts</u>
<u>Establishment of Named Endowed Professorships</u>			
The Department of Pathology Professorship (Used to provide a professorship in the College of Medicine and Public Health; provided by gifts from friends of the Department of Pathology)		\$750,000.00	\$750,000.00
The University Pathology Services Professorship (Used to provide a professorship in the College of Medicine and Public Health; provided by gifts from friends of the Department of Pathology)		\$750,000.00	\$750,000.00
<u>Establishment of Named Designated Professorship</u>			
The Honorable William B. Saxbe Designated Professorship in Law (Used to provide salary and research support for a professorship in the Moritz College of Law; provided from a gift from William B. Saxbe)	(\$37,500 per year for five years -- \$187,500.00)		
<u>Establishment of Named Endowed Fellowship</u>			
The Howard E. LeFevre 1929 Fellowship (Used to support an emerging practitioner in the Knowlton School of Architecture; provided by a gift from Howard E. LeFevre and The LeFevre Foundation)	\$273,064.09		\$273,064.09
<u>Establishment of Named Endowed Funds</u>			
The Neva Peecher Endowment Fund for the Prevention of Blindness (Used to provide research support to the College of Optometry faculty; provided by a gift from the estate of Neva Peecher)	\$92,087.84		\$92,087.84
The Goldberg Program for Excellence in Teaching Fund in History (Used to support teaching in the Department of History; provided by gifts from numerous donors)		\$31,430.00	\$31,430.00
The James C. Lewis Technical Theatre Fund (Used to support the activities of the OSU Mansfield Theatre program and to recognize an undergraduate student in theatre at OSU Mansfield; provided by gifts from Carl and Bessie Lewis, Robert Lewis, Larry J. Evans, and many friends)		\$25,035.00	\$25,035.00

REPORT ON UNIVERSITY DEVELOPMENT (contd)

THE OHIO STATE UNIVERSITY DEVELOPMENT FUND (contd)

	<u>Previous Gifts</u>	<u>Current Gifts</u>	<u>Total Gifts</u>
<u>Establishment of Named Endowed Funds (contd)</u>			
The Daniel Renn Memorial Ohio International Agricultural and Horticultural Intern Program Scholarship Endowment Fund (Used to provide travel scholarships through The OSU International Program in the College of Food, Agricultural, and Environmental Sciences; provided by gifts from the Renn family and friends of the Intern Program, Michael Chrisman, and Walter Schug)		\$25,000.00	\$25,000.00

Change in Name and Description of Named Endowed Professorship

From: The Joanne Wharton Murphy/Class of '65 Professorship of Law
To: The Joanne Wharton Murphy/Classes of 1965 and 1973 Professorship in Law

Change in Description of Named Endowed Fund

The LeFevre Foundation Fund

Change in Name and Description of Named Endowed Funds

From: The Dr. Eli G. Alcorn and Dr. John B. Alcorn Prize in Ophthalmology
To: The Dr. Eli G. Alcorn and Dr. John B. Alcorn Prize Fund in Ophthalmology

From: The Thomas E. Cavendish Scholarship Fund
To: The Thomas E. and Joanna L. Cavendish Scholarship Fund

From: The Procter & Gamble Faculty Excellence Award
To: The Robert J. Watkins/Procter & Gamble Professorship Fund

THE OHIO STATE UNIVERSITY FOUNDATION

	<u>Previous Gifts</u>	<u>Current Gifts</u>	<u>Total Gifts</u>
<u>Establishment of Named Endowed Funds</u>			
The Rachel Hoover Carter Scholarship Fund (Used to provide scholarships for students at the Columbus campus of The OSU; provided by a gift from the estate of Rachel Hoover Carter)		\$302,485.00	\$302,485.00
The Harlan Hatcher Memorial Award Fund for Academic Excellence (Used to provide awards for outstanding faculty members in the Colleges of the Arts and Sciences; provided by gifts from Mrs. Anne Hatcher and her family)		\$100,000.00	\$100,000.00

REPORT ON UNIVERSITY DEVELOPMENT (contd)

THE OHIO STATE UNIVERSITY FOUNDATION (contd)

	<u>Previous Gifts</u>	<u>Current Gifts</u>	<u>Total Gifts</u>
<u>Establishment of Named Endowed Funds (contd)</u>			
The Raul A. Hernandez, Jr., M.D. Nephrology and Critical Care Medicine Fellowship Fund (Used to provide a joint fellowship in the Divisions of Nephrology and Pulmonary and Critical Care Medicine; provided by gifts from Raul A. Hernandez and Constance McCourry Hernandez)		\$78,500.00	\$78,500.00
The Mildred Munday Scholarship Fund in Women's Studies (Used to provide a scholarship in the Department of Women's Studies; provided by gifts from numerous donors in memory of Mildred Munday)		\$50,985.00	\$50,985.00
The John E. and Charlotte B. Moore 4-H, Minority Scholarship Endowment Fund (Used to provide scholarships for 4-H minority undergraduate students; provided by gifts from family and friends of John E. Moore)		\$31,697.00	\$31,697.00
The John Bruce Family Swimming Scholarship Fund (Used to supplement the scholarship costs of a student-athlete member of the men's swimming team; provided by gifts from Dr. Timothy Duffey, Sean Sentz, Joseph Budde, family, friends, and former athletes of the late swimming coach)		\$29,096.00	\$29,096.00
The Raymond and Shirley Reiser/John F. Lyman Fund (Used for scholarships for graduate students in the College of Food, Agricultural, and Environmental Sciences; provided by gifts from Dr. Raymond Reiser and Shirley Reiser in memory of Dr. John F. Lyman)		\$25,587.00	\$25,587.00
The Gary L. Wilson Athletic Scholarship Fund (Used to supplement scholarship costs of a student athlete member of the football team; provided by gifts from Gary L. Wilson in memory of Ernie Wilson)		\$25,579.00	\$25,579.00
OSU Men's Varsity "O" Alumni Association Athletic Scholarship Fund (Used to supplement the grant-in-aid scholarship costs of a scholar-athlete member of a men's varsity team; provided by gifts from OSU Men's Varsity "O" Alumni Association)		\$25,025.00	\$25,025.00

REPORT ON UNIVERSITY DEVELOPMENT (contd)

THE OHIO STATE UNIVERSITY FOUNDATION (contd)

	<u>Previous Gifts</u>	<u>Current Gifts</u>	<u>Total Gifts</u>
<u>Establishment of Named Endowed Funds (contd)</u>			
The Keith M. Russ Chemical Engineering Endowment Fund (Used to advance the quality of teaching and research within the Department of Chemical Engineering; provided by a gift from Keith M. Russ)		\$25,000.00	\$25,000.00
David and Ellen Ryan Athletic Scholarship Fund (Used to provide scholarship costs of undergraduate athletes on the varsity men's hockey team; provided by gifts from David and Ellen Ryan)		\$25,000.00	\$25,000.00
<u>Change in Name and Description of Named Endowed Funds</u>			
From: The Herb and Dee Dee Glimcher Visiting Professorship Fund			
To: The Herb and DeeDee 1988 Glimcher Distinguished Visiting Professorship Fund			
From: Morse Scholarship Fund for Mount Scholars/ Leaders in the College of Engineering			
To: The Reginald Morse Scholarship Fund for Mount Scholars in the College of Engineering			
Total	\$365,151.93	\$2,300,419.00	\$2,665,570.93

THE OHIO STATE UNIVERSITY DEVELOPMENT FUND

Establishment of Named Endowed Professorships

The Department of Pathology Professorship

The Department of Pathology Professorship was established July 12, 2002, by the Board of Trustees of The Ohio State University with gifts from friends of the Department of Pathology.

All gifts are to be invested in the University's Permanent Endowment Fund, under the rules and regulations adopted by the Board of Trustees of The Ohio State University, with the right to invest and reinvest as occasion dictates.

The annual income shall support a professorship position that will support the advancement of medical knowledge in the field of pathology research, both basic and clinical, and shall be held by an individual who is or shall be a member of the Department of Pathology in the College of Medicine and Public Health. The position shall be held by a nationally eminent faculty member who has distinguished himself/herself in the performance of pathology research, who is NIH-funded as a principal investigator, who maintains an active productive research program, and who is an effective educator-teacher.

REPORT ON UNIVERSITY DEVELOPMENT (contd)

THE OHIO STATE UNIVERSITY DEVELOPMENT FUND (contd)

Establishment of Named Endowed Professorships (contd)

The Department of Pathology Professorship (contd)

Selection shall be made as recommended by the senior vice president for health sciences and dean of the College of Medicine and Public Health in consultation with the chairperson of the Department of Pathology. The activities of the endowed professorship holder shall be reviewed no less than every five years by the senior vice president for health sciences and dean of the College of Medicine and Public Health to determine compliance with the intent of the donor as well as the academic and research standards of the University.

It is the desire of the donors that this fund should benefit the University in perpetuity. If the need for this fund should cease to exist or so diminish as to provide unused income, then another use shall be designated by the Board of Trustees in consultation with the senior vice president for health sciences and dean of the College of Medicine and Public Health, and the chairperson of the Department of Pathology in order to carry out the desire of the donors.

\$750,000.00

The University Pathology Services Professorship

The University Pathology Services Professorship was established July 12, 2002, by the Board of Trustees of The Ohio State University with gifts from friends of the Department of Pathology.

All gifts are to be invested in the University's Permanent Endowment Fund, under the rules and regulations adopted by the Board of Trustees of The Ohio State University, with the right to invest and reinvest as occasion dictates.

The annual income shall support a professorship position that will support the advancement of medical knowledge in the field of pathology research, both basic and clinical, and shall be held by an individual who is or shall be a member of the Department of Pathology in the College of Medicine and Public Health. The position shall be held by a nationally eminent faculty member who has distinguished himself/herself in the performance of pathology research, who is NIH-funded as a principal investigator, who maintains an active productive research program, and who is an effective educator-teacher.

Selection shall be made as recommended by the senior vice president for health sciences and dean of the College of Medicine and Public Health in consultation with the chairperson of the Department of Pathology. The activities of the endowed professorship holder shall be reviewed no less than every five years by the senior vice president for health sciences and dean of the College of Medicine and Public Health to determine compliance with the intent of the donor as well as the academic and research standards of the University.

It is the desire of the donors that this fund should benefit the University in perpetuity. If the need for this fund should cease to exist or so diminish as to provide unused income, then another use shall be designated by the Board of Trustees in consultation with the senior vice president for health sciences and dean of the College of Medicine and Public Health, and the chairperson of the Department of Pathology in order to carry out the desire of the donors.

\$750,000.00

REPORT ON UNIVERSITY DEVELOPMENT (contd)

THE OHIO STATE UNIVERSITY DEVELOPMENT FUND (contd)

Establishment of Named Designated Professorship

The Honorable William B. Saxbe Designated Professorship in Law

The Honorable William B. Saxbe Designated Professorship in Law at The Michael E. Moritz College of Law was established July 12, 2002, by the Board of Trustees of The Ohio State University. It is being created as a result of an unrestricted gift from William B. Saxbe (B.A. 1940, J.D. 1948) of Mechanicsburg, Ohio.

A sum of \$37,500 per year will be spent from this fund over a five-year period which will provide salary and research support of a professorship position at the Moritz College of Law. Appointment to the professorship shall be recommended by the dean of the Moritz College of Law and provost and approved by the Board of Trustees.

The designated professorship may be renewed at the prevailing amount and term at the time of renewal.

\$37,500.00 for five years

Establishment of Named Endowed Fellowship

The Howard E. LeFevre 1929 Fellowship

The Howard E. LeFevre 1929 Fellowship was established July 12, 2002, by the Board of Trustees of The Ohio State University with a transfer from The LeFevre Foundation Fund.

All gifts are to be invested in the University's Permanent Endowment Fund, under the rules and regulations adopted by the Board of Trustees of The Ohio State University, with the right to invest and reinvest as occasion dictates.

The annual income shall be used only to create The Howard E. Lefevre 1929 Fellowship at the Austin E. Knowlton School of Architecture to support an "emerging" practitioner in the School who will teach an undergraduate studio and produce a monograph or exhibition. The fellowship shall be administered in accordance with the fellowship credentials of The Ohio State University and the Knowlton School of Architecture. The fellowship will be awarded in consultation with the University Committee on Student Financial Aid.

It is the desire of the donor that this fund should benefit the University in perpetuity. If the need for this fund should cease to exist or so diminish as to provide unused income, then another use shall be designated by the Board of Trustees in consultation with the appropriate college dean, school director, department chairperson, or program administrative officer in order to carry out the desire of the donor.

\$273,064.09

Establishment of Named Endowed Funds

The Neva Peecher Endowment Fund for the Prevention of Blindness

The Neva Peecher Endowment Fund for the Prevention of Blindness was established July 12, 2002, by the Board of Trustees of The Ohio State University with a gift from the estate of Neva Peecher.

REPORT ON UNIVERSITY DEVELOPMENT (contd)

THE OHIO STATE UNIVERSITY DEVELOPMENT FUND (contd)

Establishment of Named Endowed Funds (contd)

The Neva Peecher Endowment Fund for the Prevention of Blindness (contd)

All gifts are to be invested in the University's Permanent Endowment Fund, under the rules and regulations adopted by the Board of Trustees of The Ohio State University, with the right to invest and reinvest as occasion dictates.

Neva "Peaches" Peecher was born on August 3, 1895. Her parents came to the U.S. by boat from Germany. They settled in Chillicothe, Ohio. When Neva married a young builder, she moved to Columbus. Mr. Peecher helped build Ohio Stadium in 1923. In addition, he built many homes in the Clintonville and Upper Arlington areas, a number of those still very stately and occupied. Neva once told her husband she wished he would build a house with no corners because she was tired of cleaning them – so he did. You can still see this house on the corner of Rustic Bridge and Sheffield Streets in Old Clintonville. The house is square on the outside, but there is a round frame inside it.

Everyone in Neva's family required vision correction from childhood, so she had a deep sympathy for people living with blindness. The annual income for this endowed gift shall provide research support to the College of Optometry faculty studying issues related to the prevention of blindness.

It is the desire of the donor that this fund should benefit the University in perpetuity. If the need for this fund should cease to exist or so diminish as to provide unused income, then another use shall be designated by the Board of Trustees in consultation with the dean of the College of Optometry in order to carry out the desire of the donor.

\$92,087.84

The Goldberg Program for Excellence in Teaching Fund in History

The Goldberg Program for Excellence in Teaching Fund in History in the College of Humanities was established July 12, 2002, by the Board of Trustees of The Ohio State University with gifts from numerous donors.

All gifts are to be invested in the University's Permanent Endowment Fund, under the rules and regulations adopted by the Board of Trustees of The Ohio State University, with the right to invest and reinvest as occasion dictates.

The annual income shall be used to support teaching by both graduate teaching associates and faculty in the Department of History, based on the decision of the chairperson of the Department of History.

It is the desire of the donors that this fund should benefit the University in perpetuity. If the need for this fund should cease to exist or so diminish as to provide unused income, then another use shall be designated by the Board of Trustees as recommended by the dean of the College of Humanities in consultation with the chairperson of the Department of History in order to carry out the desire of the donors.

\$31,430.00

REPORT ON UNIVERSITY DEVELOPMENT (contd)

THE OHIO STATE UNIVERSITY DEVELOPMENT FUND (contd)

Establishment of Named Endowed Funds (contd)

The James C. Lewis Technical Theatre Fund

The James C. Lewis Technical Theatre Fund was established July 12, 2002, by the Board of Trustees of The Ohio State University with gifts from his parents, Carl and Bessie Lewis, his brother Robert Lewis, his colleague Larry J. Evans, and his many friends.

The prize is named in honor of James C. Lewis (1945-1994), a theatre artist who, as designer, performer, and director, significantly contributed to approximately 30 theatre productions at The Ohio State University at Mansfield between 1977 and 1993. As a friend and artist, his memory and the professional level of his creative work will live on in the future theatre productions of the OSU Mansfield Campus.

All gifts are to be invested in the University's Permanent Endowment Fund, under the rules and regulations adopted by the Board of Trustees of The Ohio State University, with the right to invest and reinvest as occasion dictates.

The annual income shall be used to support the activities of the OSU Mansfield Theatre program and to recognize an undergraduate student who has made outstanding contributions to the technical areas of theatre at OSU Mansfield.

It is the desire of the donors that this fund should benefit the University in perpetuity. If the need for this fund should cease to exist or so diminish as to provide unused income, then another use shall be designated by the Board of Trustees in consultation with the dean/director of the Mansfield Campus and the director of the OSU Mansfield Theatre Program in order to carry out the desire of the donors.

\$25,035.00

The Daniel Renn Memorial Ohio International Agricultural and Horticultural
Intern Program Scholarship Endowment Fund

The Daniel Renn Memorial Ohio International Agricultural and Horticultural Intern Program Scholarship Endowment Fund was established July 12, 2002, by the Board of Trustees of The Ohio State University with gifts from the Renn family and friends of the Intern Program, Michael Chrisman, and Walter Schug to honor the memory of Daniel Renn.

All gifts are to be invested in the University's Permanent Endowment Fund, under the rules and regulations adopted by the Board of Trustees of The Ohio State University, with the right to invest and reinvest as occasion dictates.

The annual income shall be used to provide undergraduate international educational travel scholarships for German students to wineries in the U.S. through The Ohio State University International Program in the College of Food, Agricultural, and Environmental Sciences. In any given year that the endowment income is not fully expended, the unused portion should be reinvested in the endowment principal.

It is the desire of the donors that this fund should benefit the University in perpetuity. If the need for this fund should cease to exist or so diminish as to provide unused income, then another use shall be designated by the Board of Trustees in consultation with the vice president for Agricultural Administration and University Outreach, and executive dean for Food, Agricultural and Environmental Sciences, or their successor, or an appropriate administrative officer, or their successor, in order to carry out the desire of the donors.

\$25,000.00

REPORT ON UNIVERSITY DEVELOPMENT (contd)

THE OHIO STATE UNIVERSITY DEVELOPMENT FUND (contd)

Change in Name and Description of Named Endowed Professorship

The Joanne Wharton Murphy/Classes of 1965 and 1973 Professorship in Law

The Law Class of '65 Endowed Fund was established February 4, 1983, by the Board of Trustees of The Ohio State University with gifts to The Ohio State University Development Fund from members of the Class of 1965 of the OSU College of Law. The professorship was established and the name was changed to The Joanne Wharton Murphy/Class of '65 Professorship of Law on November 5, 1999. The name and description were revised further on July 12, 2002.

All gifts are to be invested in the University's Permanent Endowment Fund, under the rules and regulations adopted by the Board of Trustees of The Ohio State University, with the right to invest and reinvest as occasion dictates.

The annual income shall be used to fund a professorship in The Michael E. Moritz College of Law which recognizes a distinguished scholar and teacher. Selection will be made by the dean of the Moritz College of Law.

It is the desire of the donors that this fund should benefit the University in perpetuity. If the need for this fund should cease to exist or so diminish as to provide unused income, then another use shall be designated by the Board of Trustees in consultation with the appropriate college dean, department chairperson, or program administrative officer in order to carry out the desire of the donors.

Change in Description of Named Endowed Fund

The LeFevre Foundation Fund

The Howard E. and Catharine Bonner LeFevre Scholarship Fund was established April 14, 1966, by the Board of Trustees of The Ohio State University with gifts to The Ohio State University Development Fund from Howard E. LeFevre (B.Arch.E. 1929) and Catharine Bonner LeFevre (B.S.Ed. 1929). The name was changed to The LeFevre Foundation Fund and the description was revised on July 2, 1999, and the description was further revised on July 12, 2002.

All gifts are to be invested in the University's Permanent Endowment Fund, under the rules and regulations adopted by the Board of Trustees of The Ohio State University, with the right to invest and reinvest as occasion dictates.

The annual income shall be used at The Ohio State University Newark Campus for purposes selected at least annually by The LeFevre Foundation.

It is the desire of the donors that this fund should benefit the University in perpetuity. If the need for this fund should cease to exist or so diminish as to provide unused income, then another use shall be designated by the Board of Trustees in consultation with the appropriate University officials and The Lefevre Foundation in order to carry out the desire of the donors.

Change in Name and Description of Named Endowed Funds

The Dr. Eli G. Alcorn and Dr. John B. Alcorn Prize Fund in Ophthalmology

The Dr. Eli G. Alcorn Prize in Ophthalmology was established December 14, 1925, by the Board of Trustees of The Ohio State University with a gift from Dr. Eli G. Alcorn of Columbus, Ohio. The name was changed to The Dr. Eli G. Alcorn and Dr. John B. Alcorn Prize in Ophthalmology and the description was revised on November 5, 1999. The name and description were revised further on July 12, 2002.

REPORT ON UNIVERSITY DEVELOPMENT (contd)

THE OHIO STATE UNIVERSITY DEVELOPMENT FUND (contd)

Change in Name and Description of Named Endowed Funds (contd)

The Dr. Eli G. Alcorn and Dr. John B. Alcorn Prize Fund in Ophthalmology (contd)

Gifts were made in memory of Dr. John B. Alcorn, father-in-law of Edgar T. Wolfe and grandfather of John W. Wolfe, as well as son of Dr. Eli G. Alcorn. Dr. John Alcorn was an ophthalmology physician and assistant professor emeritus in the College of Medicine, 1940. Additional gifts were received from the Robert F. Wolfe and Edgar T. Wolfe Foundation of Columbus, Ohio.

All gifts are to be invested in the University's Permanent Endowment Fund, under the rules and regulations adopted by the Board of Trustees of The Ohio State University, with the right to invest and reinvest as occasion dictates.

The annual income shall support student awards and fellowships in the Department of Ophthalmology. The Alcorn Medical Student Prize in Ophthalmology shall be awarded each year to the student in the College of Medicine and Public Health who receives the highest grade in ophthalmology or to the student who writes the most original paper on some subject connected with the eye. As income allocation permits, the Alcorn Fellowship Prize and Alcorn Research Prize shall be awarded in support of post-doctoral fellows in ophthalmology and to support graduate students who are undertaking research, both basic and clinical, in the field of ophthalmology, respectively.

It is the desire of the donors that this fund should benefit the University in perpetuity. If the need for this fund should cease to exist or so diminish as to provide unused income, then another use shall be designated by the Board of Trustees in consultation with the senior vice president for Health Sciences and dean of the College of Medicine and Public Health, and the chairperson of the Department of Ophthalmology in order to carry out the desire of the donors.

The Thomas E. and Joanna L. Cavendish Scholarship Fund

The Thomas E. Cavendish Scholarship Fund of The Porter, Wright, Morris & Arthur Endowment was established July 8, 1994, by the Board of Trustees of The Ohio State University with founding gifts to The Ohio State University Development Fund from the law firm of Porter, Wright, Morris & Arthur, and The Hubert A. and Gladys C. Estabrook Charitable Trust and friends and colleagues of Thomas E. Cavendish. The name and description were revised on July 12, 2002.

All gifts are to be invested in the University's Permanent Endowment Fund, under the rules and regulations adopted by the Board of Trustees of The Ohio State University, with the right to invest and reinvest as occasion dictates.

The annual income shall be used to provide financial assistance to one or more outstanding students who are enrolled in The Michael E. Moritz College of Law. Recipients should demonstrate an interest participating in activities other than pure academic pursuit. Awards, and the determination of size thereof, shall be made by the dean of the Moritz College of Law in consultation with the University Committee on Student Financial Aid and a committee of not more than five, nor less than three, partners of the firm Porter, Wright, Morris & Arthur; but the concurrence of such committee shall not be required as to the identity of any specific award recipient.

It is the desire of the donors that this fund should benefit the University in perpetuity. If the need for this fund should cease to exist or so diminish as to provide unused income, then another use shall be designated by the Board of Trustees in consultation with the appropriate administrative official who is then directly responsible for legal education in order to carry out the desire of the donors.

REPORT ON UNIVERSITY DEVELOPMENT (contd)

THE OHIO STATE UNIVERSITY DEVELOPMENT FUND (contd)

Change in Name and Description of Named Endowed Funds (contd)

The Robert J. Watkins/Procter & Gamble Professorship Fund

The Procter & Gamble Faculty Excellence Award was established November 7, 1997, by the Board of Trustees of The Ohio State University with gifts from Ohio State College of Law Alumni employed by Procter & Gamble. The name and description were revised on July 12, 2002.

All gifts are to be invested in the University's Permanent Endowment Fund, under the rules and regulations adopted by the Board of Trustees of The Ohio State University, with the right to invest and reinvest as occasion dictates.

The annual income shall be used to fund a designated professorship in The Michael E. Moritz College of Law until such time when the fund reaches \$750,000 to provide a fully endowed professorship. Selection shall be made by the dean of the Moritz College of Law.

It is the desire of the donors that this fund should benefit the University in perpetuity. If the need for this fund should cease to exist or so diminish as to provide unused income, then another use shall be designated by the Board of Trustees as recommended by the dean of the Moritz College of Law in order to carry out the desire of the donors.

THE OHIO STATE UNIVERSITY FOUNDATION

Establishment of Named Endowed Funds

The Rachel Hoover Carter Scholarship Fund

The Rachel Hoover Carter Scholarship Fund was established July 12, 2002, in accordance with the guidelines approved by the Board of Directors of The Ohio State University Foundation, with a gift from the estate of Rachel Hoover Carter (B.S.Bus.Admin. 1953) of Santa Rosa, California.

All gifts are to be invested by the Foundation, under the rules and regulations adopted by the Foundation's Board of Directors, with the right to invest and reinvest as occasion dictates.

The annual income shall be used to provide general scholarships for students at the Columbus Campus of The Ohio State University. These scholarships will be awarded by the Office of Student Financial Aid.

It is the desire of the donor that this fund should benefit the University in perpetuity. If the need for this fund should cease to exist or so diminish as to provide unused income, then another use shall be designated by the Foundation Board in consultation with the president of The Ohio State University in order to carry out the desire of the donor.

\$302,485.00

The Harlan Hatcher Memorial Award Fund for Academic Excellence

The Harlan Hatcher Memorial Award Fund for Excellence was established July 12, 2002, in accordance with the guidelines approved by the Board of Directors of The Ohio State University Foundation, with gifts from Mrs. Anne Hatcher and her family from Ann Arbor, Michigan.

All gifts are to be invested by the Foundation, under the rules and regulations adopted by the Foundation's Board of Directors, with the right to invest and reinvest as occasion dictates.

REPORT ON UNIVERSITY DEVELOPMENT (contd)

THE OHIO STATE UNIVERSITY FOUNDATION (contd)

Establishment of Named Endowed Funds (contd)

The Harlan Hatcher Memorial Award Fund for Academic Excellence (contd)

The annual income shall be used to provide awards for up to five outstanding faculty members in the Colleges of Arts and Sciences as selected by the provost on recommendations from the executive dean of the Colleges of the Arts and Sciences.

It is the desire of the donors that this fund should benefit the University in perpetuity. If the need for this fund should cease to exist or so diminish as to provide unused income, then another use shall be designated by the Foundation Board in consultation with the appropriate college dean in order to carry out the desire of the donors.

\$100,000.00

The Raul A. Hernandez, Jr., M.D. Nephrology and
Critical Care Medicine Fellowship Fund

The Raul A. Hernandez, Jr., M.D. Nephrology and Critical Care Medicine Fellowship Fund was established July 12, 2002, in accordance with the guidelines approved by the Board of Directors of The Ohio State University Foundation, with a gift from Raul A. Hernandez (B.S.Bus.Admin. 1983, M.D. 1989, Internal Medicine Residency 1992, and Nephrology Fellowship 1992-1994) and Constance McCourry Hernandez (B.S.Nurs. 1989), Nashport, Ohio.

All gifts are to be invested by the Foundation, under the rules and regulations adopted by the Foundation's Board of Directors, with the right to invest and reinvest as occasion dictates.

The annual income shall be used to provide a joint fellowship in the Divisions of Nephrology and Pulmonary and Critical Care Medicine in the Department of Internal Medicine for the training of physicians in nephrology and critical care medicine. Distribution shall be made at the recommendation of the directors of the Divisions of Nephrology and Pulmonary and Critical Care Medicine in consultation with the chairperson of the Department of Internal Medicine and the senior vice president for health sciences and dean of the College of Medicine and Public Health.

It is the desire of the donors that this fund should benefit the University in perpetuity. If the need for this fund should cease to exist or so diminish as to provide unused income, then another use shall be designated by the Foundation Board in consultation with the directors of the Divisions of Nephrology and Pulmonary and Critical Care Medicine, the chairperson of the Department of Internal Medicine, and the senior vice president for health sciences and dean of the College of Medicine and Public Health in order to carry out the desire of the donors.

\$78,500.00

The Mildred Munday Scholarship Fund in Women's Studies

The Mildred Munday Scholarship Fund in Women's Studies in the College of Humanities was established July 12, 2002, in accordance with the guidelines approved by the Board of Directors of The Ohio State University Foundation, with gifts from numerous donors in memory of Mildred Munday.

All gifts are to be invested by the Foundation, under the rules and regulations adopted by the Foundation's Board of Directors, with the right to invest and reinvest as occasion dictates.

REPORT ON UNIVERSITY DEVELOPMENT (contd)

THE OHIO STATE UNIVERSITY FOUNDATION (contd)

Establishment of Named Endowed Funds (contd)

The Mildred Munday Scholarship Fund in Women's Studies (contd)

The annual income shall be used to provide a scholarship for students in the Department of Women's Studies. The scholarship will be awarded in consultation with the University Committee on Student Financial Aid.

It is the desire of the donors that this fund should benefit the University in perpetuity. If the need for this fund should cease to exist or so diminish as to provide unused income, then another use shall be designated by the Foundation Board as recommended by the dean of the College of Humanities in consultation with the chairperson of the Department of Women's Studies in order to carry out the desire of the donors.

\$50,985.00

The John E. and Charlotte B. Moore 4-H, Minority Scholarship Endowment Fund

The John E. and Charlotte B. Moore 4-H, Minority Scholarship Endowment Fund was established July 12, 2002, in accordance with the guidelines approved by the Board of Directors of The Ohio State University Foundation, with gifts from family and friends of John E. Moore to The Ohio State University College of Food, Agricultural, and Environmental Sciences.

All gifts are to be invested by the Foundation, under the rules and regulations adopted by the Foundation's Board of Directors, with the right to invest and reinvest as occasion dictates.

With all other qualities being equal or unless prohibited by specific federal or state law, the annual income from this endowment shall be used for scholarships with preference given to, but not limited to, incoming minority undergraduate students who are, or have been, members of the 4-H program. Scholarships will be awarded in consultation with the University Committee on Student Financial Aid.

It is the desire of the donors that this fund should benefit the University in perpetuity. If the need for this fund should cease to exist or so diminish as to provide unused income, then another use shall be designated by the Foundation Board in consultation with the vice president for Agricultural Administration and University Outreach, and executive dean for Food, Agricultural and Environmental Sciences in order to carry out the desire of the donors.

\$31,697.00

The John Bruce Family Swimming Scholarship Fund

The John Bruce Family Swimming Scholarship Fund was established July 12, 2002, in accordance with the guidelines approved by the Board of Directors of The Ohio State University Foundation, with seed gifts from Dr. Timothy Duffey, Sean Sentz and Joseph Budde and other gifts from family, friends, and former athletes of the late swimming coach.

All gifts are to be invested by the Foundation, under the rules and regulations adopted by the Foundation's Board of Directors, with the right to invest and reinvest as occasion dictates.

The annual income shall be used to supplement the student grant-in-aid scholarship costs of a student-athlete who is a member of the men's swimming team pursuing an undergraduate degree at The Ohio State University. The recipient will be selected by the director of the Department of Athletics in consultation with the University Committee on Student Financial Aid.

REPORT ON UNIVERSITY DEVELOPMENT (contd)

THE OHIO STATE UNIVERSITY FOUNDATION (contd)

Establishment of Named Endowed Funds (contd)

The John Bruce Family Swimming Scholarship Fund (contd)

It is the desire of the donors that this fund should benefit the University in perpetuity. If the need for this fund should cease to exist or so diminish as to provide unused income, then another use shall be designated by the Foundation Board as recommended by the director of the Department of Athletics in order to carry out the desire of the donors.

\$29,096.00

The Raymond and Shirley Reiser/John F. Lyman Fund

The Raymond and Shirley Reiser/John F. Lyman Fund was established July 12, 2002, in accordance with the guidelines approved by the Board of Directors of The Ohio State University Foundation, with gifts from Dr. Raymond Reiser (Ph.D. 1936) and Shirley Reiser, College Station, Texas, in memory of Dr. John F. Lyman.

All gifts are to be invested by the Foundation, under the rules and regulations adopted by the Foundation's Board of Directors, with the right to invest and reinvest as occasion dictates.

The annual income shall be used for scholarships for graduate students in the Department of Food Science and Technology who are involved in research of Dr. Lyman's interest, such as nutrition or nutritional biochemistry, especially of lipids. Selection of recipients shall be made by the chairperson of the Department of Food Science and Technology, or his/her designee in consultation with the University Committee on Student Financial Aid.

It is the desire of the donors that this fund should benefit the University in perpetuity. If the need for this fund should cease to exist or so diminish as to provide unused income, then another use shall be designated by the Foundation Board in consultation with the vice president for Agricultural Administration and University Outreach, and executive dean for Food, Agricultural and Environmental Sciences, and the chairperson of the Department of Food Science and Technology in order to carry out the desire of the donors.

\$25,587.00

The Gary L. Wilson Athletic Scholarship Fund

The Gary L. Wilson Athletic Scholarship Fund was established July 12, 2002, in accordance with the guidelines approved by the Board of Directors of The Ohio State University Foundation, with gifts from Gary L. Wilson of Fort Myers, Florida. The scholarship is established in memory of Gary's father, Ernie Wilson, a great supporter of the Ohio State Buckeyes.

All gifts are to be invested by the Foundation, under the rules and regulations adopted by the Foundation's Board of Directors, with the right to invest and reinvest as occasion dictates.

The annual income shall be used to supplement scholarship costs of a student athlete who is a member of the football team and pursuing an undergraduate degree at The Ohio State University. The recipient shall be selected by the director of the Department of Athletics in consultation with the University Committee on Student Financial Aid.

It is the desire of the donor that this fund should benefit the University in perpetuity. If the need for this fund should cease to exist or so diminish as to provide unused income, then another use shall be designated by the Foundation Board as recommended by the director of the Department of Athletics in order to carry out the desire of the donor.

\$25,579.00

REPORT ON UNIVERSITY DEVELOPMENT (contd)

THE OHIO STATE UNIVERSITY FOUNDATION (contd)

Establishment of Named Endowed Funds (contd)

OSU Men's Varsity "O" Alumni Association Athletic Scholarship Fund

The OSU Men's Varsity "O" Alumni Association Athletic Scholarship Fund be established July 12, 2002, in accordance with the guidelines approved by the Board of Directors of The Ohio State University Foundation, with gifts from OSU Men's Varsity "O" Alumni Association, Columbus, Ohio.

All gifts are to be invested by the Foundation, under the rules and regulations adopted by the Foundation's Board of Directors, with the right to invest and reinvest as occasion dictates.

The annual income shall be used to supplement the grant-in-aid scholarship costs of a scholar-athlete who is a member of a men's varsity team pursuing an undergraduate degree at The Ohio State University. Recipients shall be selected by the director of the Department of Athletics in consultation with the University Committee on Student Financial Aid.

It is the desire of the donors that this fund should benefit the University in perpetuity. If the need for this fund should cease to exist or so diminish as to provide unused income, then another use shall be designated by the Foundation Board as recommended by the director of the Department of Athletics in order to carry out the desire of the donors.

\$25,025.00

The Keith M. Russ Chemical Engineering Endowment Fund

The Keith M. Russ Chemical Engineering Endowment Fund was established July 12, 2002, in accordance with the guidelines approved by the Board of Directors of The Ohio State University Foundation, with a gift from Keith M. Russ (M.S., Chemical Engineering, 1988, Ph.D. 1991) of Corpus Christi, Texas.

All gifts are to be invested by the Foundation, under the rules and regulations adopted by the Foundation's Board of Directors, with the right to invest and reinvest as occasion dictates.

The annual income shall be used to advance the quality of teaching and research within the Department of Chemical Engineering. The department's chairperson will be responsible for allocating these discretionary earnings.

It is the desire of the donor that this fund should benefit the University in perpetuity. If the need for this fund should cease to exist or so diminish as to provide unused income, then another use shall be designated by the Foundation Board in consultation with the appropriate department chairperson, or college dean in order to carry out the desire of the donor.

\$25,000.00

David and Ellen Ryan Athletic Scholarship Fund

The David and Ellen Ryan Athletic Scholarship Fund was established July 12, 2002, in accordance with the guidelines approved by the Board of Directors of The Ohio State University Foundation, with gifts from David and Ellen Ryan of New Albany, Ohio, and Naples, Florida.

All gifts are to be invested by the Foundation, under the rules and regulations adopted by the Foundation's Board of Directors, with the right to invest and reinvest as occasion dictates.

REPORT ON UNIVERSITY DEVELOPMENT (contd)

THE OHIO STATE UNIVERSITY FOUNDATION (contd)

Establishment of Named Endowed Funds (contd)

David and Ellen Ryan Athletic Scholarship Fund (contd)

The annual income shall be used to provide scholarship costs of student athletes who are pursuing undergraduate degrees at The Ohio State University and participating on the varsity men's hockey team. Recipients shall be selected by the director of the Department of Athletics in consultation with the University Committee on Student Financial Aid.

It is the desire of the donors that this fund should benefit the University in perpetuity. If the need for this fund should cease to exist or so diminish as to provide unused income, then another use shall be designated by the Foundation Board as recommended by the director of the Department of Athletics in order to carry out the desire of the donors.

\$25,000.00

Change in Name and Description of Named Endowed Funds

The Herb and DeeDee 1988 Glimcher Distinguished Visiting Professorship Fund

The Herb and Dee Dee Glimcher Visiting Professorship Fund was established February 5, 1999, in accordance with the guidelines approved by the Board of Directors of The Ohio State University Foundation, from the generous support of Herb and DeeDee (B.S.Land.Arch. 1988) Glimcher. The name and description were revised on July 12, 2002.

All gifts are to be invested by the Foundation, under the rules and regulations adopted by the Foundation's Board of Directors, with the right to invest and reinvest as occasion dictates.

The annual income shall be used to support a distinguished visiting professor recommended by the head of the Landscape Architecture program and the director of the Austin E. Knowlton School of Architecture. The Glimcher Professorship will be used to bring internationally acclaimed landscape architects, designers, and artists to the Knowlton School of Architecture for one or more quarters. While in residence, the Glimcher Professor will teach design studios, seminars, and/or lecture courses, interact with faculty and students, and make at least one public presentation. When appropriate, the Glimcher Professor will also provide guidance for the development of the Chadwick Arboretum.

It is the desire of the donors that this fund should benefit the University in perpetuity. If the need for this fund should cease to exist or so diminish as to provide unused income, then another use shall be designated by the Foundation Board in consultation with the director of the Knowlton School of Architecture and the head of the Landscape Architecture program, or program administrative officer in order to carry out the desire of the donors. It is the desire of the donors that this fund only be utilized by landscape architecture, not the College of Engineering or other administrative units where landscape architecture may be associated.

The Reginald Morse Scholarship Fund
for Mount Scholars in the College of Engineering

The Morse Scholarship for Mount Scholars/Leaders in the College of Engineering was established December 6, 2001, in accordance with the guidelines approved by the Board of Directors of The Ohio State University Foundation, with gifts from Alan Gordon Morse (B.A. 1980, Communication) Westerville, Ohio. The name and description were revised on July 12, 2002.

REPORT ON UNIVERSITY DEVELOPMENT (contd)

THE OHIO STATE UNIVERSITY FOUNDATION (contd)

Change in Name and Description of Named Endowed Funds (contd)

The Reginald Morse Scholarship Fund
for Mount Scholars in the College of Engineering (contd)

All gifts are to be invested by the Foundation, under the rules and regulations adopted by the Foundation's Board of Directors, with the right to invest and reinvest as occasion dictates.

The annual income shall be used to provide one or more scholarships to those students who are Mount Scholar/Leaders majoring in engineering with first preference being students majoring in electrical engineering. The scholarship will be awarded annually to a sophomore, junior, or senior Mount Scholar in consultation with the College of Engineering, Mount Leadership Society, and the University Committee on Student Financial Aid.

It is the desire of the donor that this fund should benefit the University in perpetuity. If the need for this fund should cease to exist or so diminish as to provide unused income, then another use shall be designated by the Foundation Board in consultation with the appropriate college dean, school director, department chairperson, or program administrative officer in order to carry out the desire of the donor.

**EMPLOYMENT OF ARCHITECTS/ENGINEERS,
EMPLOYMENT OF CONSTRUCTION MANAGERS,
REQUEST FOR CONSTRUCTION BIDS, AND
REPORT OF AWARD OF CONTRACTS**

Resolution No. 2003-8

LARKINS HALL REPLACEMENT
MECHANICAL ENGINEERING BUILDING REPLACEMENT
HAGERTY HALL REHABILITATION
WEXNER CENTER – BUILDING RENOVATIONS
WISEMAN HALL – EXPAND COMPREHENSIVE CANCER CENTER
STUDENT FAMILY COMMUNITY CENTER AT BUCKEYE VILLAGE
MEDICAL CENTER – CENTRAL STERILE SUPPLY DEPARTMENT
MEDICAL CENTER - HELIPAD ON RHODES HALL
WOSU RENOVATION
OARNET – HVAC AND ELECTRICAL IMPROVEMENTS
KNOWLTON SCHOOL OF ARCHITECTURE
NEWARK CAMPUS – REESE CENTER
AUTOMATED TRANSPORT SYSTEM FOR UNIVERSITY MEDICAL CENTER – PHASE I
CRAMBLETT HALL – OB/GYN CLINIC
CAMPUS GROUNDS – WOODY HAYES DRIVE REBUILD

Synopsis: Authorization to employ architect/engineering firms for the Medical Center – Central Sterile Supply Department, Medical Center – Helipad on Rhodes Hall, and WOSU Renovation projects, employ construction managers for the Medical Center – Central Sterile Supply Department and Medical Center – Helipad on Rhodes Hall projects, request construction bids for the Larkins Hall Replacement, Mechanical Engineering Building Replacement, Hagerty Hall Rehabilitation, Wexner Center Building Renovations, Wiseman Hall – Expand Comprehensive Cancer Center, Student Family Community Center at Buckeye Village, Medical Center – Central Sterile Supply Department, Medical Center – Helipad on Rhodes Hall, WOSU Renovation, and OARnet – HVAC and Electrical Improvements projects, and acceptance of the report of award of contracts for Knowlton School of Architecture, Newark Campus – Reese Center, Automated Transport System for University Medical Center – Phase I, Cramblett Hall – OB/GYN Clinic, and Campus Grounds – Woody Hayes Drive Rebuild projects is requested.

**EMPLOYMENT OF ARCHITECTS/ENGINEERS,
EMPLOYMENT OF CONSTRUCTION MANAGERS,
REQUEST FOR CONSTRUCTION BIDS, AND
REPORT OF AWARD OF CONTRACTS (contd)**

WHEREAS the University desires to proceed with the replacement of the existing Larkins Hall with an all new recreation center to be complete in two construction phases and housing a 50 meter competition pool and diving well, recreation, class and lap pools as well as 16 basketball courts, 6 multipurpose rooms, squash courts, racquetball courts, 28,000 square foot fitness center, and all new administrative and academic offices, classrooms and laboratory spaces; and

WHEREAS the total estimated project cost is \$139,799,657 and the total estimated construction cost is \$106,936,554, with funding provided by University bond proceeds (\$85,730,154) with debt service paid by fees for use of the facility, House Bill 640 (\$5,000,000), House Bill 850 (\$3,000,000), anticipated future capital appropriations (\$28,029,375), Department of Athletics (\$17,658,021) through University bond proceeds with debt service paid by Athletics, and central University Funds (\$382,107); and

WHEREAS the financing costs for this project have not yet been determined because of the uncertainty of the timing of, and level of support in, the anticipated State capital appropriations bill, and as a result the University will report back to the Board of Trustees regarding the financing costs once they are known; and

WHEREAS the University desires to demolish the existing Robinson Laboratory and construct new space for the Mechanical Engineering Department on the Robinson Laboratory site; and

WHEREAS the total estimated project cost is \$72,500,000 and the total estimated construction cost is \$51,092,993, with funding provided by House Bill 640 (\$2,500,000), House Bill 850 (\$1,000,000), future capital appropriations (\$49,000,000), and gifts to the College of Engineering (\$20,000,000); and

WHEREAS the University desires to renovate Hagerty Hall to house a portion of the College of Humanities; and

WHEREAS the total estimated project cost is \$24,400,000 and the total estimated construction cost is \$17,972,840, with funding provided by House Bill 748 (\$1,000,000), House Bill 850 (\$18,500,000), gifts to the College of Humanities (\$1,900,000), and central University funds (\$3,000,000); and

WHEREAS the University desires to renovate and retrofit the Wexner Center for the Arts to correct building envelope and system problems; and

WHEREAS the total estimated project cost is \$12,000,000 and the total estimated construction cost is \$8,600,000, with funding provided by House Bill 640 (\$1,000,000) and University bond proceeds (\$11,000,000) with debt service paid by central University funds; and

WHEREAS the University desires to construct a two-story addition to the existing comprehensive cancer center housed in Wiseman Hall; and

WHEREAS the total estimated project cost is \$7,339,702 and the total estimated construction cost is \$6,025,920, with funding provided by gifts to the James Cancer Hospital; and

WHEREAS the University desires to construct of a new community facility to provide an integrated approach to addressing the needs of the University Child Care Center and ACCESS Program for single parents and providing a new community facility at Buckeye Village, including space for administrative and maintenance offices, satellite child care center, recreation area, laundry facility, computer lab, aerobic fitness room, and meeting rooms; and

**EMPLOYMENT OF ARCHITECTS/ENGINEERS,
EMPLOYMENT OF CONSTRUCTION MANAGERS,
REQUEST FOR CONSTRUCTION BIDS, AND
REPORT OF AWARD OF CONTRACTS (contd)**

WHEREAS the total estimated project cost is \$5,400,000 and the total estimated construction cost is \$4,559,130, with funding provided by University bond proceeds with debt service paid by Office of Student Affairs; and

WHEREAS University Hospitals desires to construct a new Central Sterile Supply facility integrated into the ground floor of the new Ross Heart Hospital; and

WHEREAS the total estimated project cost is \$5,750,000 and the total estimated construction cost is \$4,700,000, with funding provided by University Hospitals; and

WHEREAS University Hospitals desires to construct a helipad on the southwest corner of Rhodes Hall Tower, extend the two elevators from the Emergency Department to serve the helipad, and provide other related renovations/relocations to accommodate this construction; and

WHEREAS the total estimated project cost is \$2,927,838 and the total estimated construction cost is \$2,357,357, with funding provided University Hospitals; and

WHEREAS the University desires to renovate space for the WOSU Stations in the Fawcett Center for Tomorrow to create radio studios, a radio reception area, teleconference rooms, and space for digital transmission equipment; and

WHEREAS the total estimated project cost is \$864,460 and the total estimated construction cost is \$705,682, with funding provided by a University line of credit to be repaid by the WOSU Stations; and

WHEREAS the University desires to improve HVAC and electrical services to the OARnet facility housed at 1454 West Lane Avenue; and

WHEREAS the total estimated project cost is \$250,616 and the total estimated construction cost is \$224,768, with funding provided by House Bill 640; and

WHEREAS resolutions adopted by the Board of Trustees on February 4, 2000, August 30, 2000, February 2, 2001, and November 2, 2001, authorized the President and/or Vice President for Business and Finance to request construction bids in accordance with established University procedures, and if satisfactory bids were received to award contracts for the following projects:

(* Recommended alternates included in these amounts)

Knowlton School of Architecture

This project constructs a new facility to house the programs of Architecture, City and Regional Planning, and Landscape Architecture. The total project cost is \$33,000,000; funding is provided by House Bill 748 (\$233,280), House Bill 790 (\$1,000,000), House Bill 850 (\$9,000,000), University bond proceeds (\$22,668,320) with debt service paid by gifts to the Knowlton School of Architecture, and Department of Physical Facilities (\$98,400). The estimated completion date is December 2003. The contracts awarded are as follows:

Design:	Wandel & Schnell Architects, Columbus, Ohio
General Contract:	P. J. Dick, Pittsburgh, Pennsylvania
Amount:	\$17,895,000 *
Estimate:	\$18,172,857 *
Plumbing Contract:	Aggressive Mechanical, Columbus, Ohio
Amount:	\$1,017,000 * +
Estimate:	\$906,208 *

**EMPLOYMENT OF ARCHITECTS/ENGINEERS,
EMPLOYMENT OF CONSTRUCTION MANAGERS,
REQUEST FOR CONSTRUCTION BIDS, AND
REPORT OF AWARD OF CONTRACTS (contd)**

Knowlton School of Architecture (contd)

HVAC Contract:	J. A. Guy, Dublin, Ohio
Amount:	\$3,626,000 * +
Estimate:	\$3,610,620 *
Electric Contract:	Buckeye Electric, Dayton, Ohio
Amount:	\$3,101,800 *
Estimate:	\$3,737,130 *
Total All Contracts:	\$25,639,800
Contingency Allowance:	\$2,022,570
Total Project Cost:	\$33,000,000

+ The Plumbing and HVAC contracts are in excess of the filed estimate of cost; however the total price of all contracts is within 10% of the total estimate of cost and is recommended for award as provided by Section 153.12 of the Revised Code.

Newark Campus – Reese Center

This project constructs an instructional technology center to support the academic mission, provide student gathering/activity spaces, and serve as a conference center for the Newark Campus community. The total project cost is \$13,870,095; funding is provided by future capital appropriations to the University (\$3,445,050) and to the Central Ohio Technical College (\$2,266,530) and gifts from the Newark Campus Foundation (\$8,158,515). The estimated completion date is August 2003. The contracts awarded are as follows:

Design:	The Collaborative, Toledo, Ohio
General Contract:	The Altman Company, Columbus, Ohio
Amount:	\$7,475,169 *
Estimate:	\$7,523,186 *
Plumbing Contract:	Kel-Par Company, Inc., Newark, Ohio
Amount:	\$445,000 +
Estimate:	\$339,682
HVAC Contract:	Romanoff Mechanical, LLC, Columbus, Ohio
Amount:	\$1,528,000 +
Estimate:	\$1,361,986
Electric Contract:	Superior Electric, Columbus, Ohio
Amount:	\$1,133,619 *
Estimate:	\$1,250,224 *
Total All Contracts:	\$10,581,788 *
Contingency Allowance:	\$774,995
Total Project Cost:	\$13,870,095

+ The Plumbing and HVAC contracts are in excess of the filed estimate of cost; however the total price of all contracts is within 10% of the total estimate of cost and is recommended for award as provided by Section 153.12 of the Revised Code.

Automated Transport System for University Medical Center – Phase I

This project provides various renovations within the Medical Center to accommodate the new automated material handling system. The total project cost is \$4,187,175; funding is provided by University Hospitals. The estimated completion date is December 2002. The contracts awarded are as follows:

**EMPLOYMENT OF ARCHITECTS/ENGINEERS,
EMPLOYMENT OF CONSTRUCTION MANAGERS,
REQUEST FOR CONSTRUCTION BIDS, AND
REPORT OF AWARD OF CONTRACTS (contd)**

Automated Transport System for University Medical Center – Phase I (contd)

Design:	Schooley Caldwell Associates, Columbus, Ohio
General Contract:	Albert M. Higley Company, Columbus, Ohio
Amount:	\$2,006,000 *
Estimate:	\$2,659,771 *
Plumbing Contract:	J. A. Guy, Dublin, Ohio
Amount:	\$297,000 +
Estimate:	\$174,461
HVAC Contract:	Martina Metal, Columbus, Ohio
Amount:	\$374,000 +
Estimate:	\$255,871
Electric Contract:	Knight Electric, Columbus, Ohio
Amount:	\$210,824 *
Estimate:	\$223,307 *
Asbestos Abatement Contract:	AHC, Inc., Columbus, Ohio
Amount:	\$74,962
Estimate:	\$97,300
Total All Contracts:	\$2,962,786
Contingency Allowance:	\$ 496,939
Total Project Cost:	\$ \$4,187,175

+ The Plumbing and HVAC contracts are in excess of the filed estimate of cost; however the total price of all contracts is within 10% of the total estimate of cost and is recommended for award as provided by Section 153.12 of the Revised Code.

Cramblett Hall – OB/GYN Clinic

This project renovates space on the second floor of Cramblett Hall to expand the OB/GYN Clinic area. The total project cost is \$1,821,025; funding is provided by University Hospitals. The estimated completion date is January 2003. The contracts awarded are as follows:

Design:	Karlsberger Companies, Columbus, Ohio
General Contract:	Corna/Kokosing Construction Company, Columbus, Ohio
Amount:	\$814,700 *
Estimate:	\$894,940 *
Plumbing Contract:	Gutridge Plumbing, Newark, Ohio
Amount:	\$195,000
Estimate:	\$195,893
HVAC Contract:	Martina Metal, Columbus, Ohio
Amount:	\$136,000
Estimate:	\$238,137
Electric Contract:	Romanoff Electric, Columbus, Ohio
Amount:	\$239,209
Estimate:	\$251,896
Total All Contracts:	\$1,384,909
Contingency Allowance:	\$206,075
Total Project Cost:	\$1,821,025

Campus Grounds – Woody Hayes Drive Rebuild

The project rebuilds the section of road between Herrick Drive and Kenny Road to carry bus traffic. Many sections have failed due to heavy vehicles and improper drainage. The total project cost is \$1,214,012; funding is provided by House Bill 640. The estimated completion date is September 2002. The contracts awarded are as follows:

**EMPLOYMENT OF ARCHITECTS/ENGINEERS,
EMPLOYMENT OF CONSTRUCTION MANAGERS,
REQUEST FOR CONSTRUCTION BIDS, AND
REPORT OF AWARD OF CONTRACTS (contd)**

Campus Grounds – Woody Hayes Drive Rebuild (contd)

Design:	HNTB Architects, Cleveland, Ohio
General Contract:	Nicholas Savko and Sons, Columbus, Ohio
Amount:	\$813,845
Estimate:	\$957,198
Electric Contract:	Complete General Construction, Columbus, Ohio
Amount:	\$159,246
Estimate:	\$200,330
Total All Contracts:	\$973,091
Contingency Allowance:	\$97,309
Total Project Cost:	\$1,214,012

NOW THEREFORE

BE IT RESOLVED, That the Interim President and/or Senior Vice President for Business and Finance be authorized to select qualified architectural/engineering firms as necessary for the Medical Center – Central Sterile Supply Department, Medical Center – Helipad on Rhodes Hall, and WOSU Renovation projects and that the fees for these services be negotiated between the firms selected and the University; and

BE IT FURTHER RESOLVED, That the Interim President and/or Senior Vice President for Business and Finance be authorized to select a qualified construction manager firms as necessary for the Medical Center – Central Sterile Supply Department and Medical Center – Helipad on Rhodes Hall projects and that the fees for these services be negotiated between the firm selected and the University; and

BE IT FURTHER RESOLVED, That the Interim President and/or Senior Vice President for Business and Finance be authorized to request construction bids for the Larkins Hall Replacement, Mechanical Engineering Building Replacement, Hagerty Hall Rehabilitation, Wexner Center – Building Renovations, Student Family Community Center at Buckeye Village, Medical Center – Central Sterile Supply Department, Medical Center – Helipad on Rhodes Hall, WOSU Renovation, and OARnet – HVAC and Electrical Improvements projects in accordance with established University and State of Ohio procedures, and if satisfactory bids are received, to issue contracts with all actions to be reported to this Board at the appropriate time; and

BE IT FURTHER RESOLVED, That, subject to an amended memorandum of understanding among the offices involved, the Interim President and/or Senior Vice President for Business and Finance be authorized to request construction bids for the Wiseman Hall – Expand Comprehensive Cancer Center project in accordance with established University and State of Ohio procedures, and if satisfactory bids are received, to issue contracts with all actions to be reported to this Board at the appropriate time; and

BE IT FURTHER RESOLVED, That pursuant to the actions previously authorized by the Board, the report of award of contracts and establishment of contingency funds for the Knowlton School of Architecture, Newark Campus – Reese Center, Automated Transport System for University Medical Center – Phase I, Cramblett Hall – OB/GYN Clinic, and Campus Grounds – Woody Hayes Drive Rebuild projects is hereby accepted.

(See Appendix I for background material and maps, page 81.)

PURCHASE OF REAL PROPERTY

Resolution No. 2003-9

**4.3 ACRES ADJACENT TO THE MARION CAMPUS
MARION, OHIO**

Synopsis: Authorization for the purchase of 4.3 acres of unimproved real property adjacent to the northwest corner of the Marion Campus is proposed.

WHEREAS the Board of Trustees of The Ohio State University is presented with the opportunity to acquire approximately 4.3 acres of unimproved real property in the City of Marion adjacent to the western boundary of the Marion Campus; and

WHEREAS the property has an appraised value of \$65,000 and the property owners, Lawrence Babich and Carl Fry, Trustees, acting through and with Karen Seckel, Executor of the Estate of James C. Neff, will sell the property at that price; and

WHEREAS the appropriate University offices have determined that the acquisition of this property is in the best interest of the University; and

WHEREAS funds for the purchase and related costs will be provided by the Marion Campus:

NOW THEREFORE

BE IT RESOLVED, That the Interim President and/or Senior Vice President for Business and Finance be authorized to purchase the approximately 4.3 acres described above in the name of the State of Ohio for the use and benefit of The Ohio State University at a cost not to exceed \$65,000, plus acquisition costs, upon such terms and conditions as are deemed to be in the best interest of the University, subject to the University receiving the necessary approvals from the Ohio Board of Regents and the State Controlling Board.

(See Appendix II for background material and map, page 111.)

ACQUISITION OF LEASEHOLD INTEREST

Resolution No. 2003-10

**COMMERCIAL AND RESIDENTIAL PROPERTY
1656-1660 NEIL AVENUE
COLUMBUS, OHIO**

Synopsis: Authorization for the purchase of leasehold interest in property at 1656-1660 Neil Avenue, within the South Campus Acquisition Area, is proposed.

WHEREAS the Board of Trustees of The Ohio State University is presented with the opportunity to acquire the leasehold interest in property at 1656-1660 Neil Avenue, adjacent to the Younkin Success Center; and

WHEREAS the fee simple to the property belongs to the University, but control of the property is through a perpetual lease held by Campus Partners for Community Urban Redevelopment, Inc.; and

ACQUISITION OF LEASEHOLD INTEREST (contd)

WHEREAS Campus Partners has agreed to sell the leasehold rights to the University at a price of \$500,000, which is consistent with the appraised value; and

WHEREAS gaining control of this property is in accordance with the Master Plan for the South Campus Acquisition Area, and the appropriate University offices have determined that the acquisition of this property is in the best interest of the University; and

WHEREAS the funds for the acquisition will be provided by the Land Purchase Account:

NOW THEREFORE

BE IT RESOLVED, That the Interim President and/or the Senior Vice President for Business and Finance be authorized to purchase the leasehold interest in the property at 1656-1660 Neil Avenue at a price not to exceed \$500,000, plus acquisition costs, upon such terms and conditions as are deemed to be in the best interest of the University, subject to the University receiving the necessary approvals from the Ohio Board of Regents and the State Controlling Board.

(See Appendix III for background material and map, page 113.)

ACQUISITION OF LEASEHOLD INTEREST

Resolution No. 2003-11

COMMERCIAL PROPERTY
1440 HAWTHORNE AVENUE
COLUMBUS, OHIO

Synopsis: Authorization to acquire the leasehold interest in the improved real property located at 1440 Hawthorne Avenue, Columbus, Ohio, on land owned by The Ohio State University is proposed.

WHEREAS in March 1999 the Board of Trustees authorized the purchase of certain real property from Quorum Health Group, and the University subsequently acquired all real property owned by Quorum Health Group under the control of Park Medical Center, subject to the parcel at 1440 Hawthorne Avenue being subject to a certain ground lease; and

WHEREAS the University Hospitals Board has determined that the purchase of this leasehold interest would support the services offered by University Hospitals East and the appropriate University officials have determined that the acquisition of this leasehold interest is in the best interest of the University and will give the University unencumbered fee simple title to the improved real property; and

WHEREAS it may be preferable for Med Ohio Health, Inc., to acquire the leasehold interest and Med Ohio Health desires to facilitate that acquisition upon receipt of a loan from the University sufficient for this purpose:

NOW THEREFORE

BE IT RESOLVED, That the Interim President and/or Senior Vice President for Business and Finance, in consultation with the Senior Vice President for Health Sciences and Dean of the College of Medicine and Public Health, is hereby authorized to purchase the leasehold interest in the improved real estate at 1440 Hawthorne Avenue upon such terms and conditions as are deemed to be in the best interest of the University, including the purchase price to be finally negotiated plus usual and customary closing costs and other acquisition costs, subject to the University receiving any necessary approvals from the Ohio Board of Regents and the State Controlling Board; and

ACQUISITION OF LEASEHOLD INTEREST (contd)

BE IT FURTHER RESOLVED, That, if it is deemed impracticable for the University to undertake this transaction and deemed appropriate for Med Ohio Health to purchase this leasehold interest, the Interim President and/or Senior Vice President for Business and Finance, in consultation with the Senior Vice President for Health Sciences and Dean of the College of Medicine and Public Health, be authorized to loan to Med Ohio Health, Inc., funds not to exceed the negotiated purchase price plus the usual and customary closing costs and other acquisition costs for the purpose of Med Ohio Health, Inc., purchasing this leasehold interest, with the loan to be subject to such terms and conditions as are deemed to be in the best interest of the University; and

BE IT FURTHER RESOLVED, That the Interim President and/or Senior Vice President for Business and Finance be and hereby is authorized to execute any and all documents, including but not limited to loan agreements, purchase agreements and assignments, as are requisite in his judgment in the circumstances to complete this transaction.

(See Appendix IV for map, page 115.)

CONSTRUCTION EASEMENT

Resolution No. 2003-12

**ARSHOT INVESTMENT CORPORATION
UNIMPROVED PROPERTY AT UNIVERSITY AIRPORT**

Synopsis: Authorization to grant a temporary construction easement to Arshot Investment Corporation for the construction of storm and sanitary sewer improvements across University property located at the University Airport is proposed.

WHEREAS the Arshot Investment Corporation has requested a temporary construction easement for the construction of storm and sanitary sewer improvements across a 21.25 acre parcel of unimproved University property at the eastern edge of the University Airport; and

WHEREAS the appropriate University offices have determined that the grant of this easement is in the best interest of the University:

NOW THEREFORE

BE IT RESOLVED, That the Interim President and/or Senior Vice President for Business and Finance be authorized to request the Deputy Director of Public Works of the Department of Administrative Services, pursuant to his or her statutory duties, to act for and on behalf of the University in developing and executing the necessary legal instruments to provide for this easement.

(See Appendix V for background material and map, page 117.)

SANITARY AND STORM SEWER EASEMENT

Resolution No. 2003-13

**CITY OF COLUMBUS
UNIMPROVED PROPERTY AT UNIVERSITY AIRPORT**

Synopsis: Authorization to grant two easements to the City of Columbus for operation of storm and sanitary sewer improvements across University property located at the University Airport is proposed.

WHEREAS the City of Columbus has requested an easement for the operation, maintenance, and repair of storm sewer improvements and an easement for operation, maintenance, and repair of sanitary sewer improvements, with both easements running across a 21.25 acre parcel of unimproved University property at the eastern edge of the University Airport; and

WHEREAS, for each easement, Columbus has requested a perpetual easement, which the University is willing to grant if the University receives the necessary authorization from the Ohio Department of Administrative Services and the General Assembly; otherwise, the term of each easement would be for 25 years; and

WHEREAS the appropriate University offices have determined that the grant of these easements is in the best interest of the University:

NOW THEREFORE

BE IT RESOLVED, That the Interim President and/or Senior Vice President for Business and Finance be authorized to request the Deputy Director of Public Works of the Department of Administrative Services, pursuant to his or her statutory duties, to act for and on behalf of the University in developing and executing the necessary legal instruments to provide for these easements.

(See Appendix VI for background material and map, page 119.)

HIGHWAY EASEMENT

Resolution No. 2003-14

**OHIO DEPARTMENT OF TRANSPORTATION
UNIMPROVED PROPERTY WEST OF THE OLENTANGY RIVER
FOR RAMPS CONNECTING TO STATE ROUTE 315**

Synopsis: Authorization to grant a perpetual highway easement to the Ohio Department of Transportation for construction and operation of a partial interchange between State Route 315 and Cannon Drive is proposed.

WHEREAS the Ohio Department of Transportation has requested a perpetual easement for construction and operation of a partial interchange between State Route 315 and Cannon Drive, across approximately 4.5 acres of unimproved University land west of the Olentangy River, north of King Avenue, and south of Herrick Drive; and

WHEREAS the appropriate University offices have determined that the grant of this easement is in the best interest of the University:

NOW THEREFORE

HIGHWAY EASEMENT (contd)

BE IT RESOLVED, That the Interim President and/or Senior Vice President for Business and Finance be authorized, pursuant to Ohio Revised Code Section 3335.11, to grant to the Ohio Department of Transportation a perpetual highway easement over approximately 4.5 acres of unimproved University land for construction and operation of a partial interchange between State Route 315 and Cannon Drive.

(See Appendix VII for background material and map, page 121.)

APPROVAL OF BUSINESS PLANS

Resolution No. 2003-15

**ROSS HEART HOSPITAL
BIOMEDICAL RESEARCH TOWER**

Synopsis: Approval of business plans required for proceeding with design and construction for the Ross Heart Hospital and Biomedical Research Tower is requested.

WHEREAS the Board of Trustees approvals on June 29, 2001, for design of the Biomedical Research Tower (formerly the Biomedical Research Facility) and on March 1, 2002, for construction of the Ross Heart Hospital required University approval of a business/financial plan for each project before proceeding with these projects; and

WHEREAS the business/financial plan for each project now has been approved by the Interim President and other appropriate University officials; and

NOW THEREFORE

BE IT RESOLVED, That the Board of Trustees hereby approves these business/financial plans, including the project budgets; and

BE IT FURTHER RESOLVED, That the total budget for each project cannot be modified without a specific resolution adopted by the Board of Trustees.

(See Appendix VIII for background material, page 123.)

**AMENDMENT AND ESTABLISHMENT OF
SUPPLEMENTAL RETIREMENT PLANS**

Resolution No. 2003-16

Synopsis: Authorization for The Ohio State University to amend The Ohio State University Supplemental Qualified Retirement Plan ("the Plan") and to give the Senior Vice President for Business and Finance, in consultation with the Office of Human Resources and the Office of Legal Affairs, authority to establish eligible deferred compensation plans under Internal Revenue Code Section 457 to provide additional investment options for employees is proposed.

WHEREAS the Board of Trustees of The Ohio State University approved the adoption of The Ohio State University Supplemental Qualified Retirement Plan (hereinafter referred to as the "Qualified Plan"), effective as of July 1, 2001; and

**AMENDMENT AND ESTABLISHMENT OF
SUPPLEMENTAL RETIREMENT PLANS (contd)**

WHEREAS the University reserved the right in Section 10.01 of the Qualified Plan to amend said Plan by action of its Board of Trustees; and

WHEREAS this Board is now desirous of approving a formal amendment to the Qualified Plan in order to make certain substantive, technical, and administrative changes therein and to comply with Internal Revenue Service requirements; and

WHEREAS the Internal Revenue Code was amended in 2001 allowing employees an opportunity to defer more compensation into certain types of deferred compensation plans under Section 457 of the Internal Revenue Code; and

WHEREAS the University desires to give employees more investment options by establishing additional eligible deferred compensation plans under Internal Revenue Code Section 457 plans to permit employees to defer additional compensation to increase their retirement benefits:

NOW THEREFORE

BE IT RESOLVED, That the First Amendment to the Qualified Plan, a copy of which is on file with the Office of the Board of Trustees, is hereby approved and adopted effective January 1, 2002; and

BE IT FURTHER RESOLVED, That the Senior Vice President for Business and Finance, in consultation with the Office of Human Resources and the Office of Legal Affairs, is hereby authorized to execute the above-mentioned Plan Amendment and any other instruments, documents, or conveyances necessary to effectuate the Amendment, to submit the Plans to the Internal Revenue Service without further ratification or action by this Board; and

BE IT FURTHER RESOLVED, That the Senior Vice President for Business and Finance, in consultation with the Office of Human Resources and the Office of Legal Affairs, in carrying out this resolution, is hereby authorized and empowered to make any necessary changes to said Plan as may be required to ensure compliance with the applicable and effective provisions of the Internal Revenue Code of 1986 and the Ohio Revised Code, and any related rules and regulations, currently in effect or as hereinafter amended, and to take such further action as may be necessary or advisable to implement this resolution without further ratification or action by this Board; and

BE IT FURTHER RESOLVED, That the Senior Vice President for Business and Finance, in consultation with the Office of Human Resources and the Office of Legal Affairs is authorized to establish additional deferred compensation plans under Internal Revenue Code Section 457 to provide additional investment options for employees, to amend existing retirement plans established under Internal Revenue Code Section 457, and to make any necessary changes to such plans as may be required to ensure compliance with the applicable and effective provisions of the Internal Revenue Code of 1986 and the Ohio Revised Code, and any related rules and regulations, currently in effect or as hereinafter amended, and to take such further action as may be necessary or advisable to implement this resolution without further ratification or action by this Board, provided that for any additional plans or amendments to any plans, all contributions to such plans shall be elective employee contributions only.

(See Appendix IX for background material, page 137.)

Upon motion of Ms. Hendricks, seconded by Ms. Longaberger, the Board of Trustees adopted the foregoing resolutions by unanimous roll call vote, cast by Messrs. Patterson, Sofia, Slane, McFerson, Borrer, and Judge Duncan, Meses. Longaberger, Hendricks, and Davidson.

PRESENTATION ON FY 2002-2003 CURRENT FUNDS BUDGET

President Edward H. Jennings:

I'd like to call now on Provost Ed Ray and Senior Vice President Bill Shkurti to present Resolution #17 and, following their presentation, I will recommend the approval of the budget.

Provost Edward J. Ray: [Overhead Presentation]

Thank you, Mr. President. We'd like to provide you with a brief summary of our recommendations for the budget for Fiscal Year 2003 and say a word or two about the budget environment that we think we'll be dealing with over the course of the next year or so.

We want to talk about our budget allocations for the next year and, as always, we want to remind ourselves that those budget allocations have to be aligned with the goals of the Academic Plan. Again, listed here are those goals: to have world-class faculty; to build extraordinary academic programs; to make Ohio State one of the leading universities in the world; to enhance the quality of the teaching and learning environment; to enhance and better serve the student body; to create a diverse university community; and to help build Ohio's future.

Let me turn to Bill and ask him to talk about the fiscal environment we find ourselves in.

Mr. William J. Shkurti:

The fiscal environment is something we've been talking about here and elsewhere over the last couple months, so I won't go into detail.

Obviously, this has been a very difficult year leading up to this budget, and I want to echo what President Jennings said about how much we appreciate the governor protecting higher education in this last round of cuts. No matter how difficult where we are is, it would be even more difficult if he was not able to do that. Some other state agencies had to take bigger cuts as a result, and we appreciate that. Even though he was able to protect us -- and there are still some numbers that are being sorted out -- when this is all sorted out, our state support will still be below where it was two years ago, even before taking inflation into account.

Some of the other things we've already talked about, in terms of the revenue from student fees, is something we started talking about last year. What this chart does is track state support and tuition and fees as a percentage of the total general funds budget for the last 20 years. The top line is state support. As you can see, 20 years ago when Ed was introduced as president the first time, state subsidy was up about 70 percent. It declined in the first budget crisis and then went up a little bit and has declined steadily since. Last year, the two lines crossed -- the lower line being manifested pretty clearly and underscores the importance of what President Jennings said earlier about us turning to other sources of funding.

In addition to this problem, we've also had competition for pay raises for our faculty and staff, which has fallen behind a lot of our competitors. We went through a process where we've eliminated nearly 600 budgeted jobs throughout the University to help deal with this problem. Although the budget we're presenting to you is balanced, there is continued uncertainty in the state budget picture and we're going to need to continue to be on our guard.

PRESENTATION ON FY 2002-2003 CURRENT FUNDS BUDGET (contd)

Mr. Shkurti: (contd)

While the budget picture is uncertain, not only here but across the country, we do have increased competitive pressures on salary and student financial aid.

Ed Ray will now talk about how we're trying to focus the resources we have to continue to make progress towards the Academic Plan.

Provost Ray:

If you look at the next slide this really lists the four major priorities that we identified for Fiscal Year 2002. Competitive faculty and staff compensation – what I would say there is that we feel we've made a good first installment on this. We believe that the average compensation for faculty and staff will be up about 4.7 percent this year, and that will be about one percent above the average for the benchmarked peer institutions. I'll remind you that we began in a position of several percentage points behind that position. So while we've made a good start, a good down payment on providing competitive faculty and staff compensation, this is a strategy that we'll have to follow for the next several years.

The second objective was to have a series of enhancements to our undergraduate programs and we talk about some of the things that we did during FY 2002. In this FY 2003 budget we continue to improve the first-year experience, to expand living/learning centers, to improve advising, and to increase budgets in high-demand areas. We're beginning a process – you heard a bit about it in the Academic Affairs Committee meeting this morning – to review undergraduate curriculum and the way we organize our activities throughout the arts and sciences. We obviously have projects like Larkins Hall and the Main Library renovation, all of which contribute to the student experience.

One of our four major goals is to have a major biomedical research initiative. You've had conversations about the Biomedical Research Tower going forward into FY 2003 and we've discussed these on other occasions. There are a number of other activities that we'll be pursuing. The President mentioned the newly-funded Mathematical Biosciences Institute, a multidisciplinary effort. That's really one of a number of multidisciplinary national centers we've set as a target for ourselves to establish here at Ohio State.

We have a number of other projects that we're beginning to move forward with that have consequences for the availability of research space as well. The Heart Hospital, the psychology building, the renovations of Jennings Hall, the Knowlton School of Architecture building, the building for mechanical engineering, and the physics building.

The last objective that we set for FY 2002 was the creation of the Kirwan Institute for the Study of Race and Ethnicity in the Americas. Obviously, that effort will continue forward and we're very excited about John Powell joining us to be director of that institute. But it's important to note that we'll be continuing our efforts with respect to a number of other diversity initiatives, including additional resources to the Multicultural Center and further development of programs in Latino/Latina Studies, Asian/American Studies, Disability Studies, and American Sign Language.

Another element of what we're doing to manage our affairs more effectively and align both the generation and allocation of resources more effectively with the goals of the Academic Plan has been to change the way we do budgets. We've had some discussion at other meetings about that.

PRESENTATION ON FY 2002-2003 CURRENT FUNDS BUDGET (contd)

Provost Ray: (contd)

In a sense, the new budget process identifies the sources and uses of funds, overlays our sense of priorities and directions we get from our Academic Plan on how resources ought to be used, and how matters ought to be expensed. We're moving from an environment where we replace historically-based funding with incremental increases year-to-year, with something that looks more like performance-based funding.

We're also decentralizing decisions regarding both revenues and expenses to the colleges. I would add, that each of the colleges are, in fact, preparing their own resource allocation plans that get down to the department-level in terms of both revenues and costs. We think that this activity will make the flow of revenues and expenses more transparent to all of us and, in the process, make it possible for us to increase accountability at every level in the use of those resources.

This really is the culmination of about a five-year plan and we've had much discussion about how we ought to structure this new budget process. It was effective July 1 and, in a job like mine, quiet is a sign of triumph. So I think we're off to a good start. We think this process will help us focus the allocation of resources and align the use of those resources with the Academic Plan objectives that we've set for ourselves. But obviously, a budget process in and of itself is not panacea – we still have some real challenges out there.

To give you a sense of how this is playing out, this slide gives you an indication the gains for some of our colleges in the Fiscal 2003 budget. On average, the general funds budget increase is seven percent. You can see in key areas: Medicine and Public Health, Optometry, Business, Pharmacy, Human Ecology, Social and Behavioral Sciences, and Humanities, we have increases above the seven percent and, in several cases, double, close to double, or more than double the average increases.

Let me stop and ask Bill to say something about the consequences of the FY 2002 budget for our support units.

Mr. Shkurti:

You may wonder how, in a time of budget stress, we're able to come up with the kind of increases that are shown up there for the colleges. Obviously, this is an academic institution and what we have to look out for first is the academic core. That means some of the support units did not fare as well. That was a differential decision.

As you see, the units involved in the support of sponsored research -- which are the three top units listed there -- all are having double-digit increases. That isn't because the provost or the president just felt like being kind to them. Rather, you may have seen we've had over the last two or three years a consistent increase in the amount of sponsored research we're bringing into the institution. That in turn then requires the appropriate support these units are supposed to provide and, in a way, reflects the increase in funding from that source. That means the other support units are left with a pretty bare table. You'll see the three biggest ones there -- Student Affairs, Business and Finance, and Academic Affairs -- are virtually flat. In some cases a little increase and that is including salary and benefits, because of the way we budget.

That means if they are flat and are given 4.5 percent increases in pay and absorbing 22 percent increases in benefits, they are doing what they are doing

PRESENTATION ON FY 2002-2003 CURRENT FUNDS BUDGET (contd)

Mr. Shkurti: (contd)

with fewer people. So a lot of the job losses we've talked about are from those units. Obviously that is not a situation we feel we can sustain over the long run nor do we want to sustain it. But we felt in a time of budget difficulty, if we could both protect our academic units and those units that were generating sponsored research -- which also generate revenues -- that over the long run, the University would be better off. I think that is true, but we obviously are going to have a long-term problem if we don't find some way of getting more resources into those critical support units.

Mr. Sofia:

The reduction -- seven tenths of one percent -- in Student Affairs' money, is that staff or student programs?

Mr. Shkurti:

Mr. Sofia, the way these support units were budgeted is that central monies were juggled around enough so that with the standard reallocation of 3.5 percent, all those units could grant a 4.5 percent pay raise and absorb the benefit costs. Part of this then depends on what portion of the budgets of those units were personnel and benefits, as opposed to other sources. Although Student Affairs did not receive an increase enabling it to do more things, it was not cut deliberately to be negative. It is simply the way the central balancing of the benefits and salary costs worked out.

Bill Hall is also here if he wants to elaborate any on what that is. Obviously he had to make reductions in personnel as well. But the reductions he made, as well as the reductions in Business and Finance and Academic Affairs -- the reallocation that resulted in job loss was the same 3.5 percent. They were not singled out for more. In a way that number reflects an accounting balancing.

Ms. Longaberger:

Is it administrative expenses or does that include programmatic costs?

Mr. Shkurti:

It includes some programmatic expenses.

Mr. William H. Hall:

It did include some programmatic decreases. Most of it was administrative cuts, primarily in the salary lines. When I first took over, I did not fill two assistant vice president positions. I have since eliminated probably another 25 positions throughout the division.

Of the 650 full-time staff within Student Affairs, probably 80 percent are on the earnings operations -- the residence hall system, the food service operations, and the hotels.

Ms. Longaberger:

I want to be clear that it is not a reflection that we're cutting programs for students.

PRESENTATION ON FY 2002-2003 CURRENT FUNDS BUDGET (contd)

Mr. Hall:

I am trying not to, but we did make some program cuts this year.

Provost Ray:

If you remember, we had discussions both in October when we sent out guidelines to the academic and support units for helping us deal with the \$20 million in budget cuts from the state, and then we reviewed them and approved them in the spring. We went area by area, to figure out how we were going to deal with the financial difficulties we had in a way that was most protective of the academic core and the Academic Plan objectives that we have. So Bill, as with all vice presidents, worked very hard with his staff to figure out where administrative reductions might be taken, rather than to cut into programs. And where programs had to be scaled back, they determined where the relative priorities were among those programs for students.

Mr. Sofia:

We understand that. But our concern is with the core student activity, because that's what the University is for. We want to make sure students enjoy their experience at Ohio State and that they have the resources on that particular side – not the building, not the overhead – and they are being taken care of. I think the critical backbone of this University is students.

Provost Ray:

In fact, I think what Bill and other vice presidents would be able to tell you in more detail are actual reallocations that they made even while they were having to make choices to eliminate or reduce some things. They were actually enhancing some other things on a prioritized basis.

Mr. Shkurti:

I think the bottom line is the actual impact that students will feel will be minimal in large part because of the good job Bill has done in addressing these. But obviously, this level of reduction is not sustainable over time without having a severe impact on our students. And so as we start planning for next year, we are going to make sure we don't have to repeat this kind of thing.

Remember this is general funds only, there are some other sources of funding that we're using. Coca-Cola money is being used to help maintain and expand student life; and the Affinity Card funds are being used to help maintain, expand, and protect student programs. Your concerns are well taken and I think when you see the budget unfold over the next year, you'll see that we have protected those core programs.

In regards to the financial implications, the FY 2003 budget is balanced. Part of why the college budgets went up is because of enrollment increases, and the budget reductions to support units that we mentioned, and neither of these is sustainable over the long run. We don't want to be the biggest University in the country. We want to be the best. That means we have to be selective in terms of our enrollment growth. To the degree our enrollments grow because our retention goes up, that's a good thing, but they cannot grow indefinitely while we maintain the services we have. Nor can we indefinitely cut our support units and maintain the services we have.

PRESENTATION ON FY 2002-2003 CURRENT FUNDS BUDGET (contd)

Mr. Shkurti: (contd)

The other thing this budget has done is replenish our reserves that had been spent earlier. I'm talking particularly about the Rainy Day Fund, but that's \$10 million in an \$800 million general funds budget and a \$2.5 billion overall budget. It is better to have those reserves than not have them. But they are the panacea themselves, and if there happens to be additional cuts -- and we hope there aren't beyond those already announced -- obviously we're going to have to go back and look again at what we're doing.

As we look ahead to the 2004 and 2005 biennium, I think saying that the state budget picture is very uncertain at this time is a bit of an understatement. There are a lot of issues that need to be worked out over the next several months which, in turn, will affect FY 2004 and 2005.

A fourth item that I think tends to get overlooked as we talk about the general fund, is that many of our non-general fund units are also under financial stress as a result of the slowdown in the nation's economy and budget cuts elsewhere. For example, we've known for the last two years the Hospitals have been having a difficult time dealing with cuts in their government reimbursement programs. Last month, we talked about the success Transportation and Parking was having in getting more students to ride the bus. In turn, this created more expenses on that side of the ledger, and we're going to have to look at their budget. Our development program is being very successful in bringing in additional funds, but they're in part dependent on growth in the endowment to help pay for our development activities. And as the stock market has deteriorated over the last several months, that's affected our ability to support development. So we're going to be tracking all of these units to make sure they're able to continue their mission, as well, in this very difficult budget picture.

Finally, the fifth item -- and President Jennings' alluded to this earlier -- and it certainly appears that for the foreseeable future, the University will continue to become less dependent on state funds and more dependent on other sources of funds. We receive a substantial amount of state money even after the cuts, so it's not like we can afford to turn our back on the state nor should we, nor on that source of funds. But we're also going to have to look at other sources of funds, and that will have both financial implications and programmatic and strategic implications.

This next slide is a sample of the different kinds of non-general funds sources and the projected increases in the next fiscal year. As you can see, some of those are pretty healthy and those are good, those are things we want to do. Unfortunately, that doesn't translate dollar per dollar in taking pressure off the general fund.

For example, the private grants and contracts are often restricted to very specific uses and that might be research. Or it might be a contribution a donor makes that helps the University, but it doesn't pay the light bill and it doesn't pay salaries. Another example is the health system revenues. These revenues are mainly patient revenues for medical care and, obviously, they're paying that money to get better medical care, not to support the rest of the University.

I went into greater detail on those other numbers in the Fiscal Affairs Committee meeting, so I won't do that here. Again, the important point to make is that the University is working very hard to find other sources of funding to offset the reductions in state support. These sources are not unlimited and we're going to still have to work on a variety of different areas to keep ourselves sound financially.

PRESENTATION ON FY 2002-2003 CURRENT FUNDS BUDGET (contd)

Provost Ray:

Let me just quickly say something about the strategic implications of all that we've suggested so far. The first point I would make is that, as I tried to indicate briefly in discussing the four goals that we had for FY 2002 and what we'll be able to do in FY 2003, these aren't the best of times. The University will in fact be able to make progress on its strategic goals, but not at a pace at which we might hope.

The second point is that after much to do about tuition increases here and elsewhere, when the dust settled we observed that tuition for undergraduate students at Ohio State is still below the average for both continuing and new students compared to other state universities in Ohio.

The third observation is that as we indicated, we had plans for reallocating existing resources. Those went very well and, as a consequence, even in these times we were able to provide faculty and staff with compensation increases on average of one percent, or perhaps a little more, above the market, as measured by our benchmark peers. That's good, but that's something we're going to have to try to sustain as a strategy over the next several years to get to our midterm objective of being at the median of the compensation levels among our benchmark peers.

The fourth observation is that the differential between the kinds of increases in revenues that are available to the colleges versus the support units. We expect in the immediate future that most of the strain will be felt, in fact, in our academic support services and that includes areas like the libraries, instructional technology, housekeeping, and elsewhere.

Finally, Bill's last table showed the success we'd had in areas other than the state's share of instruction in terms of revenue increases. The president referred to it in his remarks, but the reality is that over the course of time the University will, in fact, have to adopt characteristics that are more representative of private universities if we're ever to achieve our objective of being one of the truly excellent universities in the world. The change in the budget process that I mentioned earlier is one very critical element in helping us to change the culture and change the way we do business given the new realities we face.

Mr. President, that concludes our remarks. I know Bill and I would be happy to entertain questions or comments.

Mr. Patterson:

The current funds budget was considered in the Fiscal Affairs Committee meeting. Are there any questions?

APPROVAL OF FISCAL YEAR 2002-03 CURRENT FUNDS BUDGET

Resolution No. 2003-17

Synopsis: Approval of the budget for Fiscal Year 2002-03 is proposed.

WHEREAS the State has passed its budget for Fiscal Years 2002 and 2003, which includes funding levels for State institutions of higher education; and

WHEREAS fee increases for the Columbus and Regional Campuses and compensation levels were approved at previous meetings of the Board of Trustees; and

APPROVAL OF FISCAL YEAR 2002-03 CURRENT FUNDS BUDGET (contd)

WHEREAS other levels of resources and expenditures have been identified for the 2002-03 fiscal year; and

WHEREAS fees other than tuition also need to be approved; and

WHEREAS appropriate planning and consultation within the University has been accomplished, and the Interim President now recommends approval of the Fiscal Year 2002-03 budget:

NOW THEREFORE

BE IT RESOLVED, That the University's Current Funds Budget for Fiscal Year 2002-03, as described in the accompanying text and tables, be approved, with authorization for the University to make expenditures within the projected income levels; and

BE IT FURTHER RESOLVED, That fees other than tuition be approved as specified in the accompanying text and tables as well as other fees submitted to and approved by the Office of Business and Finance in the course of the budget process including changes to the late registration and late payment of fees for all students retroactive for FY 2002, as specified in the accompanying tables.

Upon motion of Mr. McFerson, seconded by Ms. Hendricks, the Board of Trustees adopted the foregoing resolution by unanimous roll call vote, cast by Messrs. Patterson, Sofia, Slane, McFerson, Borrer, and Judge Duncan, Mses. Longaberger and Hendricks.

(See Appendix X for background material on Current Funds Budget FY 2002-2003, page 143.)

--0--

STUDENT RECOGNITION AWARD

Mr. Shultz:

It gives me great pleasure to introduce the Board of Trustees' Student Recognition Award winner. This award is given to a student who has demonstrated outstanding academic leadership and service to The Ohio State University and today's recipient is no different as a representative of the Ohio Agricultural Research and Development Center. Nominated by the director of OARDC, Dr. Steve Slack, today's recipient has shown tremendous ability in research in the field of animal sciences.

Matthew Cannon received his Ph.D. degree from Ohio State in animal sciences in 2001. Previously, he received his Bachelor of Science degree at Oregon State University in animal sciences. While at Oregon State, Matt discovered his interest in dairy cattle reproduction. Instead of attending veterinary school, as he had originally planned, Matt instead opted to pursue a career in research.

Matt joined the Department of Animal Sciences here at Ohio State as a Ph.D. student in 1996. Specifically, Matt was drawn to the Ohio Agricultural Research and Development Center to work with Dr. Joy Pate, focusing on reproductive physiology. And Dr. Pate is in the audience today supporting Matt.

During his studies at Ohio State, the concepts that he proposed for his Ph.D. dissertation were further developed into a grant proposal to the National Institute of Health. The proposal, which was successfully funded, addressed questions of how the immune system regulates the regression of a transient ovarian endocrine gland. In these studies, Matt uses the cow as a model system to study human ovarian physiology. His findings are significant because they are the only known example in which the expression of the genes in question changes in the

STUDENT RECOGNITION AWARD (contd)

Mr. Shultz: (contd)

absence of an autoimmune disorder. These discoveries will also have great significance for understanding the broader aspects of autoimmune diseases.

In 2001 Matt received the Krauss Director's Award for Excellence in Research at the OARDC conference. Currently, Matt is working in his research area in Dr. Pate's lab. He hopes to continue his research and intends to submit another grant proposal to the NIH to carry out experiments related to those in his current research.

Looking towards the future, Matt is very interested in rounding out his academic experience in teaching. He hopes to develop a class in fundamental immunology for pre-med and pre-vet students. This enthusiasm for teaching and his proven strength in research make Matt Cannon an ideal candidate for the Board of Trustees' Student Recognition Award.

Matt, on behalf of President Jennings and the entire Board of Trustees, let me congratulate you on all of your achievements here at Ohio State. We want to wish you the best of luck as you pursue your career and we hope you do it here at Ohio State. Congratulations.

Dr. Matthew J. Cannon:

Thank you for presenting me with this award. This is sort of a shock, and I'm continually surprised because I do what I do and the recognition is foreign to me.

I want to first thank Dr. Pate for her unending support in allowing me to carry out this work, and take a crazy idea and run with it and develop it to the point of a successfully funded NIH proposal. Also, I want to thank Dr. Slack for nominating me for the award, and the Board for presenting me with this award.

My experience at Ohio State, and particularly at OARDC, has been nothing but a positive one. It is a wonderful working environment. I've experienced a lot of good collaborations in my time here. I've enjoyed it to the extent that I've actually decided to stay for an indefinite period of time as a post-doc and attempt to pull down some further extramural funding to carry on this research and further expand and develop this angle.

Once again, thank you for presenting me with this award, to Dr. Pate for the support, and for Dr. Slack for nominating me. Thank you.

--0--

PRESENTATION ON P-12 INITIATIVES

Provost Edward H. Ray:

As we've discussed on other occasions, the College of Education is involved in a set of activities that is increasingly linked with faculty and academic programs across the University. Today, we will hear about two of them. First, Professor Daryl Siedentop will give a brief overview of selected activities from our formal P-12 Initiative, an outgrowth of our University-wide outreach and engagement efforts and for which he is serving with distinction as director.

Then we will hear from Donna Evans, dean of the College of Education, and Randy Smith, vice provost in Academic Affairs, on a new University-wide initiative relating to teacher preparation. You should have packets before you

PRESENTATION ON P-12 INITIATIVES (contd)

Provost Ray: (contd)

that provide information on each of those programs. I would suggest that perhaps we can hear both presentations and then I know that Daryl, Donna, and Randy would be happy to entertain questions or comments at the end of their presentations. Daryl --

Dr. Daryl L. Siedentop:

Thank you, Ed. Chairman Patterson, President Jennings, ladies and gentlemen, the P-12 project was created in the Academic Plan in 2000 as part of the redefinition of The Ohio State University land-grant mission. The goal was to significantly strengthening our effectiveness and scope and the commitment to improving P-12 education in Ohio, with a special focus on the education of underserved children and youth.

I want to share with you this morning three initiatives we've undertaken in our first full year of existence. I invite you to visit the P-12 website, which is listed in the brochure in your packet.

A major goal for P-12 from the beginning was to create an institutional presence for The Ohio State University in research and policy at the state-level. The initiative we have created to achieve that goal is called, "The Ohio Collaborative Research and Policy for Schools, Children, and Families." The Ohio Collaborative is a statewide research and policy center focused on Ohio education from the early years through the 12th grade. The administrative center is at The Ohio State University, but the collaborative will do its work through teams of faculty from institutions of higher education throughout Ohio. We're just completing an asset inventory of the research and policy strengths of faculty in Ohio's colleges and universities and, to date, we have had more than 100 faculty nominated for affiliated faculty status. These faculty come from 25 public and private colleges and universities in Ohio.

I want to acknowledge the very strong support we got from Chancellor Rod Chu at the beginning of this initiative. In fact, the letter that was sent to all the presidents of public and private colleges and universities in the state announcing the creation of the collaborative was co-signed by Chancellor Chu and President Kirwan.

The collaborative will do its work in teams that are organized along policy and research expertise. We intend for the work to be particularly responsive to the needs of the House and Senate Education Committees, the Ohio Department of Education, the Board of Regents, and the Governor's Office.

In your packet there are three examples of some initial work we have done in the few months we have been in business. The first is a research and policy primer, which focuses on the efficacy of small schools in mitigating the effects of poverty on student achievement in urban areas. We prepared this for a day-long symposium that we co-sponsored with Columbus Public Schools and the Columbus Education Association, built around the Columbus School Building Initiative.

The second example deals with school readiness and is prepared to assist the policy seminar for Governor Taft's "Families and Children First initiative."

The third example is an agenda for a statewide symposium that the Ohio Collaborative hosted on June 21, to help universities and school districts learn more about the "No Child Left Behind" legislation and especially the scientific-

PRESENTATION ON P-12 INITIATIVES (contd)

Dr. Siedentop: (contd)

based research criterion that appears well over 100 times in that legislation. University and school district teams attended this and we had several visitors from the Department of Education and OERI in Washington, and from the Ohio Department of Education. We together tried to figure out what it is the legislation demands of universities and school districts.

The second initiative -- again for which there is a one-page description in your packet -- is something we call, "Community Connection." Students at Ohio State are increasingly interested in service projects and service learning courses. However at Ohio State, a very large and diffuse environment, it is difficult for students to identify and connect with service opportunities in the community and especially in schools and agencies.

In collaboration with the Service Learning Roundtable and the Office of Student Affairs, the P-12 project has created the Community Connection, which is a web-based volunteer interface system. This system operates fairly simply. For instance, an elementary school could post on the web that they would like to have mathematics tutors, they need them from 1:00 to 1:45 p.m. on Monday, Wednesday, and Friday, the school is located in this position, and this is the way you would get there accessing public transportation. We are particularly interested in students with these backgrounds.

Ohio State students can look at these things on the web and find a volunteer or service opportunity that fits their interests and their schedules. The system will allow the agency or school to track the service of these and produce a record, for the first time really at Ohio State, a database concerning our students' involvement in the community. This web interface will be fully operational this autumn.

The third initiative I want to share with you is an initiative that is really embedded within our neighborhood schools program called, "The Learning Bridge." The Learning Bridge was created to serve the large objectives of Campus Partners. The Learning Bridge serves the boys and girls who attend Columbus Public Schools and who live within the Campus Partners boundaries, and local agencies.

We have a number of projects going on and there is a list of them in your packet, but I want to focus this morning particularly on one that we think is tremendously exciting. Through the leadership of Dean David Andrews of the College of Human Ecology, we will build in the Weinland Park Area an early education center that will serve 150 young children from toddlers through preschool. As you know, this is one of the most difficult areas of the City of Columbus.

This early education center will be co-located with the renovated and rebuilt Weinland Park Elementary School. If you know that area, you also know that abutting the property of the elementary school is a Columbus city park that now serves primarily teenagers. It has the typical park things: basketball courts and softball diamonds. We are in preliminary discussions with the City of Columbus to rethink that park as a children and families' park with initiatives particularly in the academic progress of young children.

We really anticipate and have high expectations that this early education initiative will produce an opportunity for us to examine the possibilities of a seamless web of care and education for children who are severely disadvantaged from the time they are toddlers through their graduation from 5th grade and movement into the middle school. We hope that we can demonstrate through this the kind of

PRESENTATION ON P-12 INITIATIVES (contd)

Dr. Siedentop: (contd)

systemic intervention that may be needed to produce dramatic improvements in school performance in high poverty urban areas.

Thanks very much for your time. I do hope you have a chance to look at our website. You will also find on our website that inventory of all the programs that are P-12-oriented in The Ohio State University – there are more than 140 of them. It's a searchable web interface – you can punch up secondary school of science and out will come the programs at Ohio State that support secondary school of science.

Thank you very much.

Dr. Randy Smith:

I'd like to introduce another important initiative that's underway at the University right now that's relating to the preparation of future teachers. This is a topic that is of considerable interest at the national level – all states and major institutions are discussing it. Part of it is linked to the broad idea of the need for deeper subject area content in the preparation of teachers. That is leading to discussions between faculty and colleges of education and their counterparts, primarily in the colleges of the arts and sciences.

We began looking at it through the Provost's Office in the late 1990s. Vice Provost Garland and I -- who have worked on several initiatives together -- pulled together a group of faculty from education and the arts and sciences to begin talking about the issue as a work group. This was particularly important to us because for us the approach has been the Master of Education for certification. So we were giving a little bit more attention to undergraduate approaches.

Then in 1999, the Board of Regents and Chancellor Chu, asked if Ohio State would be interested and willing to partner with Ohio University and Wright State University in what the Regents were identifying as a teaching and learning initiative. What they were after was the idea of showing the importance of teacher preparation as an institutional commitment – not any particular part of the university, but as an institutional commitment. So the three institutions worked together for about 12-15 months to talk about how they were proceeding in this area. It was a very productive year to year-and-a-half discussion.

At Ohio State that led to the establishment of the "University Teacher Education Council (UTEC)" by Provost Ray in March 2001. If you hear the acronym UTEC, that's what that refers to. This is a 30-member council that includes faculty from the Colleges of Education and the Arts and Sciences and other colleges, like Human Ecology. These faculty have been brought together to talk about the issue of teacher preparation, particularly as it relates to deeper content. For example, my academic area is in the arts and sciences in geography and that would be a social studies area in K-12. So I would be partnered with somebody from social studies education in that sense, so the two of us would be at the table at the same time.

To show the institutional commitment to this, the council is co-chaired by my colleague, Dean Evans, and me. I had two major charges: 1) the provost asked us to provide background preparation for all the members of the council to understand current standards, licensure, etc.; and 2) to begin to work -- and Dean Evans will talk about this in a minute -- in workgroups to determine how Ohio State should proceed.

PRESENTATION ON P-12 INITIATIVES (contd)

Dr. Smith: (contd)

UTEC has had eight full meetings in the last 12-15 months. We've participated in several Board of Regents-related conferences, and President Kirwan and several of us attended one just recently at the beginning of May. So the group has been proceeding.

I'd now like to ask Dean Evans to tell you about some of the activities of the group in the last few months.

Dean Donna B. Evans:

Teacher preparation is the education reform issue today everywhere. In Ohio, through changes in teacher licensure and Governor Taft's Commission on Teaching Success, and the nation, through the reauthorization of the Elementary and Secondary Act – No Child Left Behind – the focus has been on the preparation of teachers as integral to improving student achievement. We at Ohio State intend to maintain our position of strength through the work that many of our faculty are engaged in.

As you heard, teacher preparation at Ohio State is both a University commitment and also a prime emphasis in the College of Education. Within the framework of UTEC, working groups were created to implement the vision of the UTEC council. At your places is a red folder which contains a copy of what those groups look like. There are nine of them. They really represent the program areas in teacher preparation and their partners in the various colleges that we're working with.

For the past year-and-a-half our faculty have been working with the Office of Academic Affairs, the Colleges of Humanities, Arts and Sciences, Mathematical and Physical Sciences, Human Ecology, colleagues from the OSU regional campuses, Ohio Department of Education, and the local school districts to redesign and reinvigorate both our pre-service and our advanced educator preparation programs. Associate Dean Charles Hancock, who could not be with us today, is coordinating this work.

All the programs are being developed as academically, pedagogically, and technology-rich based on national, state, and professional standards. There are a lot of standards that teacher preparation programs have to pay attention to. In that same packet, I put some of the standards that we have to pay attention to as we develop these programs.

In addition to the national and state standards, the programs were charged with looking at the research that relates to teacher preparation and also with developing strong evaluative components. One of the things we have not done such a good job of, not only at Ohio State but in the profession, are evaluating what we do.

In addition, the working groups were charged with providing a seamless transition from undergraduate to graduate education. We believe, however, that one size does not fit all in preparing teachers and other educators. So the programs will vary in implementation.

For example, we have three programs that have moved to undergraduate initial licensure. Which is different for Ohio State. Those programs are Sport and Leisure Study Education, Technical Education and Training, and Technology Education. The Early Childhood Teacher Preparation Program, Teacher Education Licensure Program has collaborated with the College of Human

PRESENTATION ON P-12 INITIATIVES (contd)

Dean Evans: (contd)

Ecology to ensure a seamless transition from their undergraduate program to our Master of Education in early childhood education. Most of you may remember this as elementary education. We don't call it that anymore because of the new licensure.

The School Psychology Program has added an urban focus option, but will remain a graduate-level program. The Middle Childhood Teacher Education Program is in collaboration with the Colleges of the Arts and Sciences developing an interdisciplinary program. That's probably one of our most ambitious and creative activities occurring right now.

The Social Studies Teacher Education Program has developed, in collaboration with their appropriate university colleagues, personalized study programs beginning at the undergraduate-level and culminating at the graduate-level in our college. The Educational Leadership Program, Principal Preparation, has developed in collaboration with the school districts and the Ohio Department of Education, an urban-focused cohort masters degree program that will be offered on site in the schools.

Actually, we're a work in progress. However, it must be noted that in the short time -- and it is a short time for an academic institution -- and due to the unprecedented work of the UTEC working groups, the college curriculum committee, in cooperation of Randy and the University Curriculum Committee, most of the work has been completed in just a little over a year. It has moved through the approval process at both the college and the University-levels, with an implementation date due of fall 2003.

Phase II of our work includes engaging in a college-wide program of evaluation to identify where our teacher preparation programs are most effective and where they are less effective. Now to complement the work of our redesigned teacher preparation programs, we created something that we call the College of Education Office of Outreach and Engagement, and there is a brochure in your folder about that.

The purpose of that office is to provide on site, collaboratively designed, customized professional development to school-based personnel. These courses are graduate, non-degree and meet the rigorous standards required for graduate course work. This office has been open for a year and during its first year, has provided more than 150 courses to address the specific needs of school districts in Franklin County.

Thank you very much for the opportunity to speak to you about the work that my colleagues and I are engaged in as we set about to not only prepare excellent teachers, but to provide professional development to keep them right up to speed.

Dr. Smith:

Let me just wrap up by saying that different groups are looking at each of these new licensure areas and asking how we should proceed as an institution within them. It is really been a tremendous cooperative effort between the Arts and Sciences and the College of Education.

Let me add that UTEC will continue to work this coming year. The provost has asked that this group monitor how these various programs will play themselves

PRESENTATION ON P-12 INITIATIVES (contd)

Dr. Smith: (contd)

out. Getting them up and running is one thing – monitoring how they're doing is another.

Many faculty in the Arts and Sciences, particularly in the College of Mathematical and Physical Sciences and Biological Sciences, are particularly interested in taking the lead in UTEC. Particularly this next year they are interested in some topical areas that are of some interest to them as they relate to research. Later this summer I'm convening a subgroup from within UTEC to talk about the research dimension that can emerge from this whole new approach or rethinking of the teacher preparation process.

Donna and I have given a combined presentation here, but I do consider this to be -- personally in the time that I've been at Ohio State -- a very important initiative that is moving forward through the system. So thank you for your time. We'd be happy to answer any questions on either Daryl's or our presentations.

Mr. Patterson:

Any questions?

Ms. Hendricks:

My understanding is that at Ohio State, a teacher gets a master's degree to teach. They get an undergraduate degree in an area of specialty. Is that right? Or are there teachers who can get a teaching degree and be fully qualified with an undergraduate degree?

Dean Evans:

As of Autumn 2003 there will be some. This is what we looked at as we redesigned our programs. What you're saying, Ms. Hendricks, is absolutely correct – we were a “graduate only” program. We will still basically be a graduate program. The difference is that in the transition from undergraduate to graduate school, there will be collaboration between undergraduate programs and graduate programs.

As we evaluated that model, one of the things that was clear is that sometimes students could finish an undergraduate degree, but there had been no collaboration between the program they would map and the College of Education. So the student may or may not have taken all the right things, and may or may not be eligible for admission to the College, so that was problematic. That is the seamless transition that we're trying to achieve.

Ms. Hendricks:

Thanks, that is helpful.

Mr. McFerson:

I'm not sure if I should direct this question, Randy, to you or Dean Evans, or Daryl, but let me just state it.

I'm very much impressed with this community connection program. I think it's wonderful that you're helping students at a very early age in their lives understand the importance of giving back to a community. There is a valuable service they can render. But I'd like to ask you to talk for a second or two about

PRESENTATION ON P-12 INITIATIVES (contd)

Mr. McFerson: (contd)

what the faculty are doing in this area. It is one thing for the faculty to provide these tools for students, but I think the faculty themselves are in a position across the campus, not just in the College of Education, to render some valuable service in the community. Particularly in these areas of helping create a vision or a model for these young children to consider higher education or to consider maybe careers in education or whatever. Would you talk about that, as to the outreach that the faculty personally are doing in the community, instead of just from the student perspective?

Dr. Siedentop:

The outreach is rather substantial. As I said, we have well over 125-130 separate initiatives that one could reasonably coalesce under P-12 outreach initiatives. These come from the departments and the colleges throughout the University.

One of the things, Mr. McFerson, that we have tried very hard to do is to remind ourselves constantly that the University's outreach has to involve its research, teaching, and service missions. There is a historic tendency on campus to think about outreach only as service, and some of the most valuable outreach is outreach in teaching and research. So we have just an extraordinary amount of activity in departments all over campus. The Writing Institute and the Ohio History Teaching Institute – every college has some very substantial outreach activities. Many of them are service-oriented and involve faculty, others, in fact, are more teaching and research.

In chemistry, we have the “Wonders of the World” project that is now in five or six schools in Central Ohio that uses local scientists from Battelle, Chemical Abstracts, and other places to produce elementary schools' hands-on science projects. They come and really stay for three years – the first year is training, the second year is implementation, the third year they do it themselves, and the school is left with the equipment and expertise to do hands-on science projects with young children. So it's a lot of that stuff going on.

Frankly, given the nature of Ohio State, it's been difficult for us to find out as much about them as we'd like to, but we work very hard. Our database is getting complete on a day-to-day basis.

Dean Evans:

I would just like to add to that. I think that it has been one of the major strengths of the work that Daryl's been doing -- creating that database, because we are so large. When the schools ask us, there has been criticisms about what is Ohio State doing. We're able to say, very specifically, what some of these things are. Sometimes one school district may know that it is happening and another doesn't, and they could be interested in it. So that is an important activity that has been occurring and it is in progress.

Dr. Siedentop:

Our next major project next year in our Learning Bridge is an internship project. We're going to try to take young adolescents from the five high schools that serve the boys and girls who live in the Campus Partners area and provide internships for them at Ohio State. These internships are not only designed to

PRESENTATION ON P-12 INITIATIVES (contd)

Dr. Siedentop: (contd)

support their academic work in high school, but also their sense of career possibilities. Columbus Public Schools has an internship requirement and we wanted to get as many of these youngsters on our campus as possible.

Mr. McFerson:

I only conclude that President Jennings has been a marvelous example of one who works extensively in the community. I think that there is a role for University employees – faculty, staff, and others – to give time, in addition to what they do as faculty members in their area of research and teaching. It is good for these people to physically be in the community rendering service. We encourage our corporate citizens to do this, and I think the University should always keep in mind that it too can play a visible, active role by giving up an hour or two a month or whatever to help those less fortunate.

President Jennings:

Certainly I continue to encourage and will continue to encourage people to volunteer. We are a nation that has a tradition of volunteerism and our University's services can be both part of the mission and part of their community responsibility. I consider it a responsibility of all of us to help out in the community.

Mr. McFerson:

Keep up the good work.

Mr. Patterson:

Thank you very much. There are so many people who do so much heavy lifting around the University. As you know, Karen and I have recently worked with Randy on the Regional Campus Commission and he worked on the update to the annual Academic Plan. Randy, I don't know how you do it all, but what I've seen on the Regional Campus Commission Plan is excellent. I believe it will come before the Board at the September meeting.

--0--

Mr. Patterson:

I'd like to note that State Representative Jim Carmichael has joined us. Jim, if you would raise your hand; he will also be joining us for lunch. Thank you, all, very much.

--0--

Thereupon the Board adjourned to meet Friday, September 6, 2002, at The Ohio State University College of Veterinary Medicine, Columbus, Ohio.

Attest:

William J. Napier
Secretary

James F. Patterson
Chairman

Larkins Hall Replacement**315-1999-188****PROJECT CAPTAIN:**

David Chapman, Facilities Planning & Development - Architecture, 292-5715

REQUESTING AGENCY:

Recreational Sports

PROJECT LOCATION:

0346 - LARKINS HALL

AGE:

1931

GR. SQ. FT.:

353,126

PROJECT DESCRIPTION:

This project will replace the existing Larkins' Hall facility with an all new recreation center to be completed in two construction phases. The new facility will be a 604,800 square foot facility that will house a 50 meter competition pool and diving well, recreation, class and lap pools, as well as 16 basketball courts, 6 multipurpose rooms, squash courts, racquetball courts, 28,000 square foot fitness center and more. The new center will also house all new administrative and academic offices, classrooms, and laboratory spaces. A satellite facility housing gyms, turf gym, and adventure programs are also a part of the project.

MILESTONES:

	Projected	Revised	Actual
Arch/Eng Approved B/T	12/04/1998		12/04/1998
Construction Manager Approved B/T			02/02/2000
Bidding Approved B/T	10/03/2000	07/12/2002	
Arch/Eng Contract	03/31/2000		08/02/2000
Schematic Design Approval	03/13/2000	04/27/2001	05/24/2001
Design Development Approval	07/24/2000	10/29/2001	12/12/2001
Construction Document Approval	03/19/2001	08/01/2002	
Bid Opening	09/17/2001	09/01/2002	
Award of Contracts	11/01/2001	11/01/2002	
Construction Start	11/12/2001	11/02/2002	
Report of Award to B/T	12/07/2001	12/07/2002	
Completion	05/13/2005	07/25/2005	

FUNDING INFORMATION:

Central Univ Funds	\$ -	\$ 382,107	
Dept. of Athletics	14,058,021	17,658,021	
Future Capital Appropriations	32,950,797	28,029,375	
House Bill 640	-	5,000,000	
House Bill 850	3,000,000	3,000,000	
Univ Bond Proceeds	82,327,044	85,730,154	
Total	\$ 132,335,862	\$ 139,799,657	

USES:

Bond Financing	\$ -	\$ 1,251,076	
Construction	\$ 89,373,268	\$ 106,936,554	
Construction Manager	\$ 2,374,382	\$ 5,880,074	
Contingency	25,423,444	10,243,590	
Design	6,354,904	8,233,071	
Equipment	7,149,265	5,583,916	
Percent for Art	320,000	330,294	
State Architect		50,000	
Univ Administration	1,340,599	1,291,082	
Total	\$ 132,335,862	\$ 139,799,657	

COMMENTS:

Feasibility study completed in 1996 by Hastings & Chevetta identified a project of \$120,000,000 in 1996 dollars. On February 4, 2000, the Board of Trustees approved a budget increase to \$136,028,118 to include construction manager for the project. The increase to \$139.8 million is due to increased costs of pool construction and potential construction bond issuance due to anticipated Capital Bill cuts and/or delays.

Larkins Hall Renovation / Addition

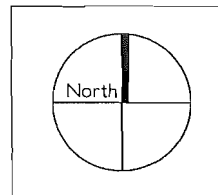
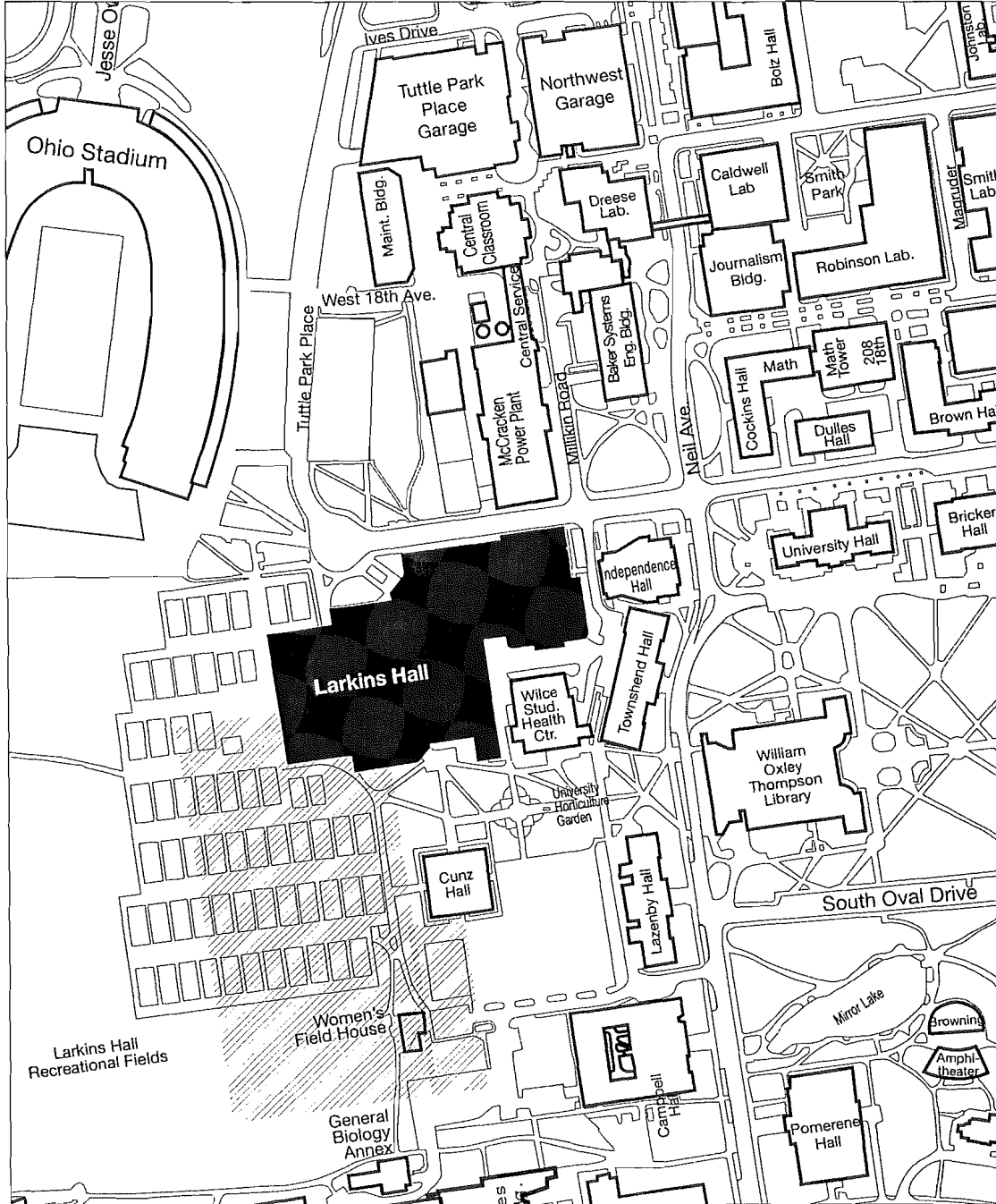

Office of Business and Finance
Office of Facilities Planning and Development

January 12, 2001

Mechanical Engineering Building Replacement

315-1999-192

PROJECT CAPTAIN:

Lori Seeger, Facilities Planning & Development - Architecture, 688-3757

REQUESTING AGENCY:

College of Engineering

PROJECT LOCATION:

0075 - ROBINSON LABORATORY

AGE:

1908

GR. SQ. FT.:

97,271

PROJECT DESCRIPTION:

This project will demolish the existing Robinson Lab and construct new space for the Mechanical Engineering Department on the Robinson Lab site.

MILESTONES:	Projected	Revised	Actual
Arch/Eng Approved B/T	02/05/1999		02/05/1999
Construction Manager Approved B/T			02/02/2000
Bidding Approved B/T	07/01/2002	07/12/2002	
Arch/Eng Contract	05/30/2000	06/15/2002	
Schematic Design Approval	11/23/2000	06/30/2002	05/01/2002
Design Development Approval	02/21/2001	9/27/02	
Construction Document Approval	07/26/2001	04/21/2003	
Bid Opening	10/01/2002	05/26/2003	
Award of Contracts	12/01/2002	09/02/2003	
Construction Start	01/01/2003	09/08/2003	
Report of Award to B/T	02/01/2003	08/05/2003	
Completion	01/01/2006	09/09/2005	

FUNDING INFORMATION:

Dev - Engineering	\$ -	\$ 20,000,000	
Future Capital Appropriations	61,000,000	49,000,000	
House Bill 640	-	2,500,000	
House Bill 850	1,000,000	1,000,000	
Total	\$ 62,000,000	\$ 72,500,000	

USES:

Construction	\$ 45,014,992	\$ 51,092,993	
Construction Manager	\$ 3,151,049	\$ 3,091,126	
Contingency	4,503,514	5,109,310	
Design	3,826,274	4,087,439	
Equipment	4,501,499	5,109,299	
Moving	-	304,531	
Swingspace Renovation	-	2,500,000	
Percent for Art	435,000	490,000	
State Architect	50,000	50,000	
Univ Administration	517,672	665,302	
Total	\$ 62,000,000	\$ 72,500,000	

COMMENTS:

Academic siting study recommended that it stay at the present site and have phased construction and phased demolition to accommodate on going academic program. An additional \$10.5 million was added to the project, included in the Capital Request for the 2003-2004 Biennium, to insure that we meet program needs and reflect current economic conditions. Formerly known as Robinson Laboratory Replacement.

Mechanical Engineering Building Replacement

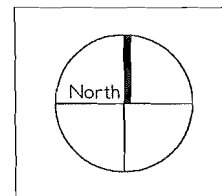
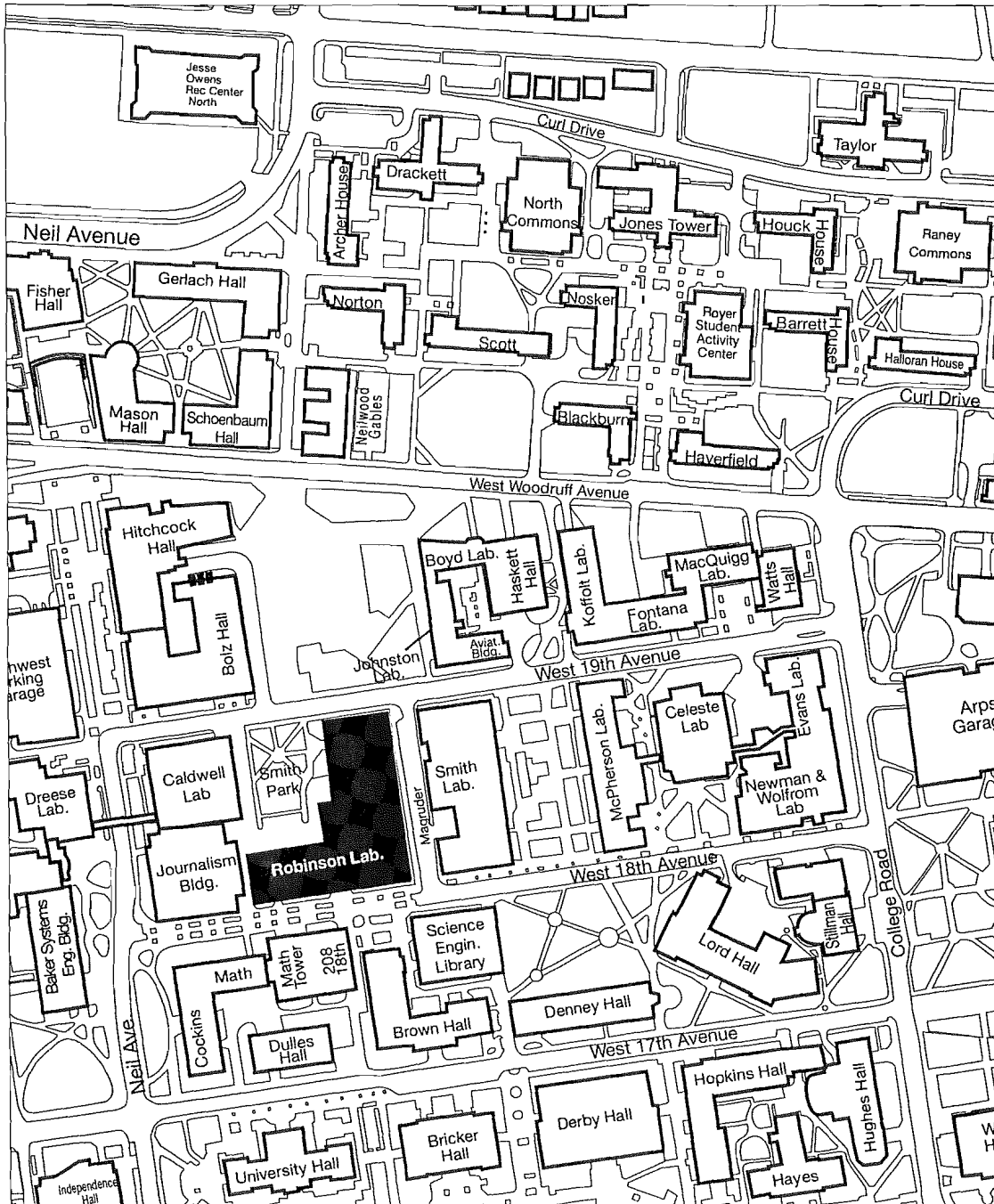

Office of Business and Finance
Office of Facilities Planning and Development

July 3, 2002

Hagerty Hall Rehabilitation**315-1999-191****PROJECT CAPTAIN:**

Christine Lawson, Facilities Planning & Development - Architecture, 292-4458

REQUESTING AGENCY:

College of Humanities

PROJECT LOCATION:

0037 - HAGERTY HALL

AGE:

1924

GR. SQ. FT.:

131,506

PROJECT DESCRIPTION:

Rehabilitate the entire building, including building system replacement and interior redesign of the spaces to house a portion of the College of Humanities.

MILESTONES:

	Projected	Revised	Actual
Arch/Eng Approved B/T	11/01/1996		11/01/1996
Bidding Approved B/T	09/01/1998	07/12/2002	
Arch/Eng Contract			03/06/2000
Schematic Design Approval	10/31/1997	09/30/2001	05/01/2001
Design Development Approval	01/30/1998	12/20/2001	12/20/2001
Construction Document Approval	05/29/1998	09/02/2002	
Bid Opening	10/01/1998	08/08/2002	
Award of Contracts	12/01/1998	10/23/2002	
Construction Start	12/01/1998	10/23/2002	
Report of Award to B/T	12/01/1998	12/06/2002	
Completion	12/31/1999	04/22/2004	

FUNDING INFORMATION:

Central Univ Funds	\$ -	\$ 3,000,000	
Dev - Humanities	1,000,000	1,900,000	
House Bill 748	1,000,000	1,000,000	
House Bill 850	18,500,000	18,500,000	
Total	\$ 20,500,000	\$ 24,400,000	

USES:

Construction	\$ 15,491,795	\$ 17,972,840	
Contingency	1,150,960	1,729,784	
Design	1,385,347	1,781,533	
Equipment	2,102,744	2,506,183	
Percent for Art	185,000	185,000	
State Architect	184,154	50,000	
Univ Administration	-	174,660	
Total	\$ 20,500,000	\$ 24,400,000	

COMMENTS:

Original project budget of \$20,500,000 approved by the Board of Trustees on February 5, 1999. Project budget increased to reflect 2002 dollars and improved alignment of space to meeting programmatic needs.

Hagerty Hall Rehabilitation

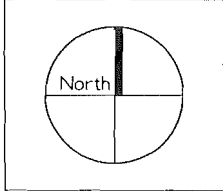
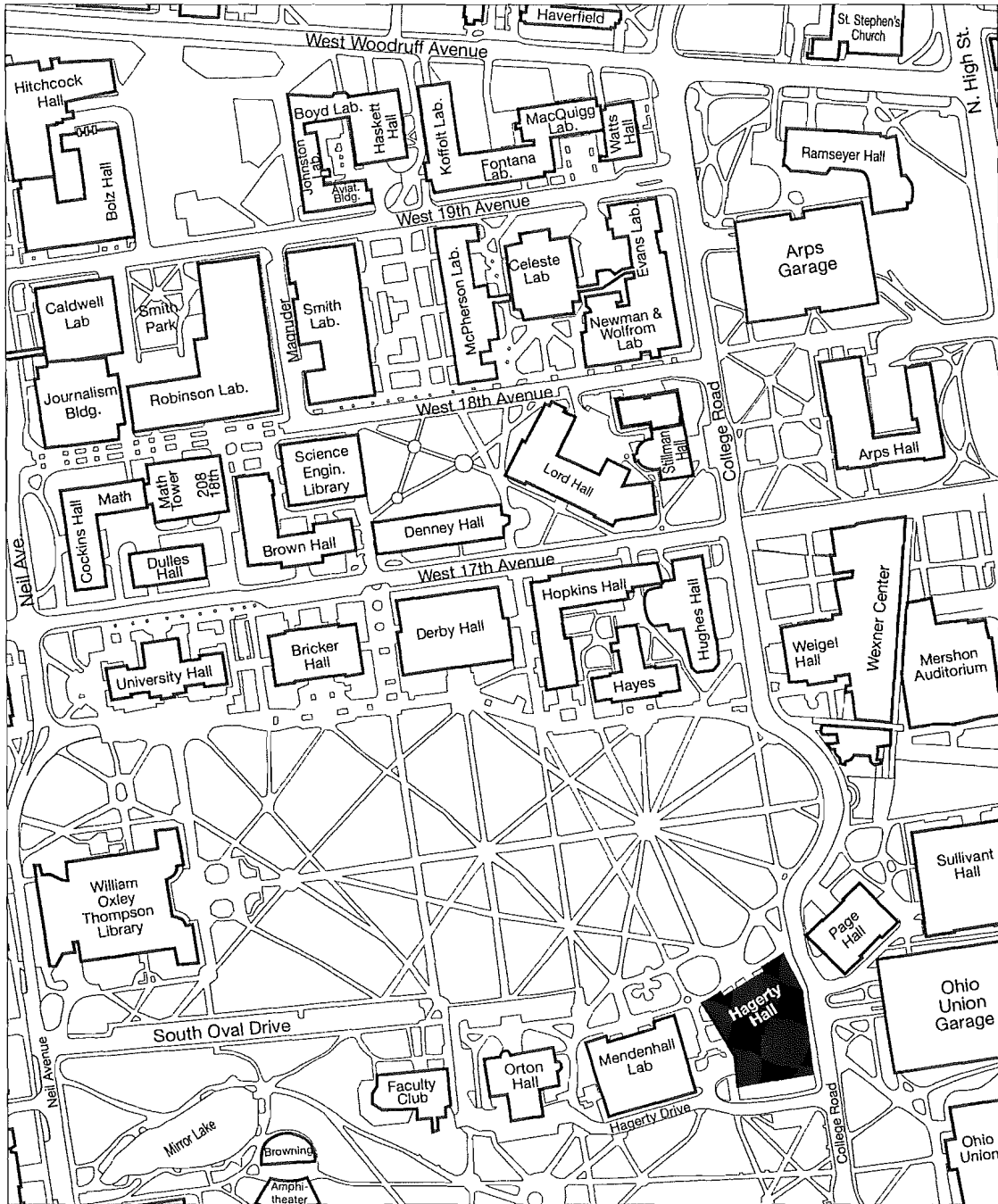

Office of Business and Finance
Office of Facilities Planning and Development

December 9, 2000

Wexner Center - Building Renovations

315-2000-914

PROJECT CAPTAIN:

Scott Conlon, Facilities Planning & Development - Architecture, 292-0983

REQUESTING AGENCY:

Wexner Center

PROJECT LOCATION:

0386 - WEXNER CENTER FOR THE ARTS

AGE:

1989

GR. SQ. FT.:

129,047

PROJECT DESCRIPTION:

Renovation and retrofit of the Wexner Center for the Arts to correct building envelope and system problems.

MILESTONES:

	Projected	Revised	Actual
Arch/Eng Approved B/T	08/30/2000		02/02/2001
Construction Manager Approved B/T	04/06/2001		04/06/2001
Bidding Approved B/T	09/01/2001	02/01/2002	02/01/2002
Arch/Eng Contract	01/12/2001	06/23/2001	06/26/2001
Schematic Design Approval	05/04/2001	01/15/2002	02/15/2002
Design Development Approval	09/21/2001	10/18/2002	
Construction Document Approval	03/08/2002	09/02/2002	
Bid Opening	04/10/2002	11/01/2002	
Award of Contracts	05/24/2002	12/03/2002	
Construction Start	05/25/2002	12/18/2002	
Report of Award to B/T	06/01/2002	02/01/2003	
Completion	11/29/2003	11/19/2003	

FUNDING INFORMATION:

Central Univ Funds	\$	9,000,000	\$	11,000,000
House Bill 640		1,000,000		1,000,000
Total	\$	10,000,000	\$	12,000,000

USES:

Construction	\$	7,000,000	\$	8,600,000
Construction Manager	\$	420,000	\$	530,000
Contingency		876,000		1,092,400
Design		895,000		923,600
Moving		515,000		515,000
Testing		210,000		210,000
Univ Administration		84,000		129,000
Total	\$	10,000,000	\$	12,000,000

COMMENTS:

Initial project budget of \$1 million was to provide the feasibility, preliminary design, and cost estimate for the project. Project budget of \$10 million approved by the Board of Trustees on February 1, 2002. Project budget increased to \$12 million to cover additional quality improvements to building systems, including skylight, roof, and mechanical systems. When plaza work is completed & tested, additional work may be needed on the planters if leaks are still occurring. If so, planter project (preliminary estimate \$750,000) will come forward as a separate project to the Board. Present estimate does not include this work.

Wexner Center - Building Renovations

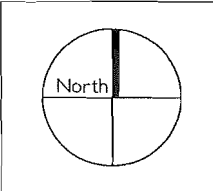
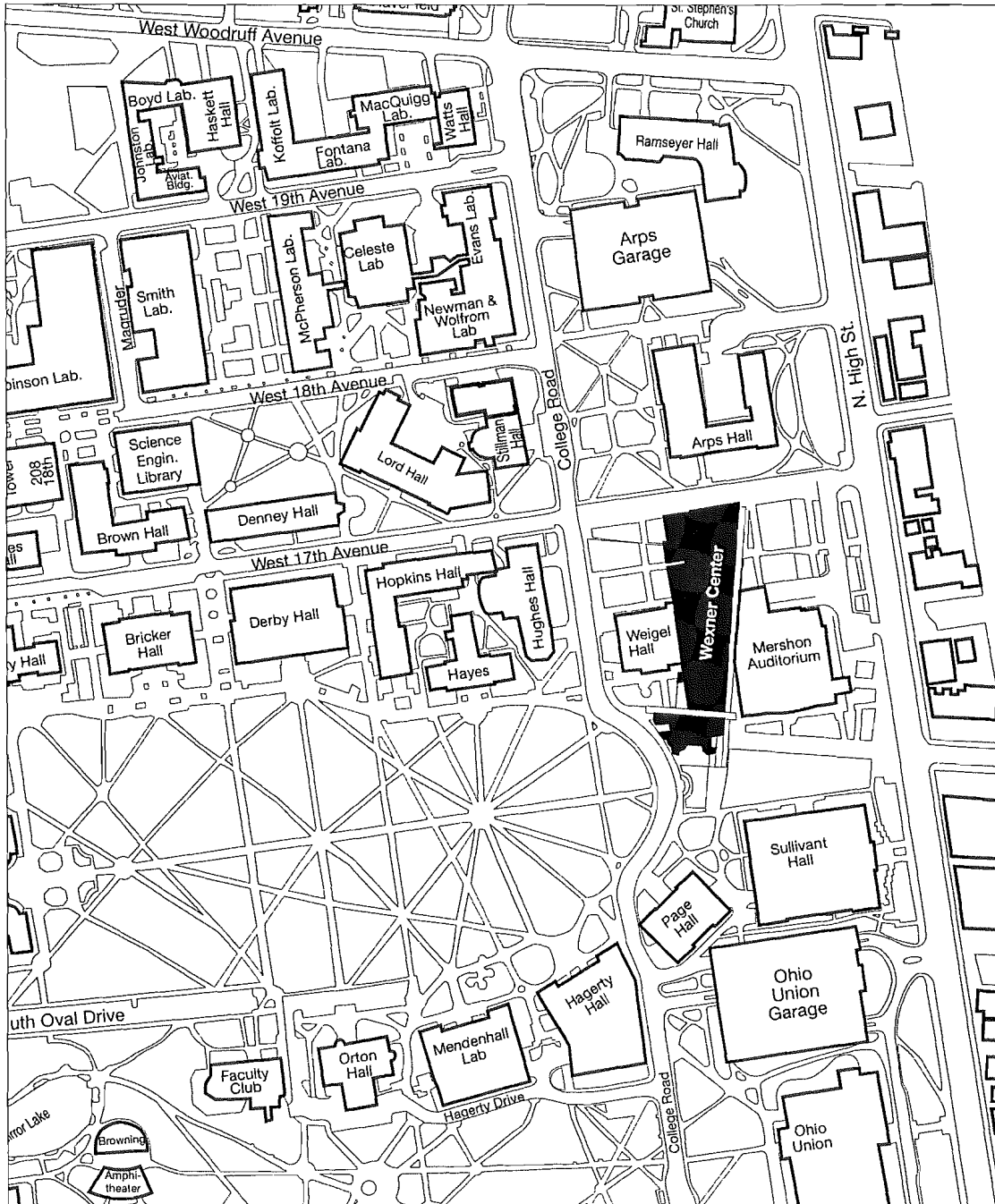

Office of Business and Finance
Office of Facilities Planning and Development

December 9, 2000

Wiseman Hall - Expand Comprehensive Cancer Center

315-1999-957

PROJECT CAPTAIN:

Sara Herridge, Facilities Planning & Development - Architecture, 292-0381

REQUESTING AGENCY:

Health Science Administration

PROJECT LOCATION:

0157 - WISEMAN HALL

AGE:

1960

GR. SQ. FT.:

81,693

PROJECT DESCRIPTION:

Design and construct a two-story addition of approximately 20,000S.F to the existing Comprehensive Cancer Center (10,000S.F. per floor). The addition will extend the third and fourth floors out over the north side, second floor of Wiseman

MILESTONES:	Projected	Revised	Actual
Arch/Eng Approved B/T	02/04/2000	03/03/2000	03/03/2000
Bidding Approved B/T	02/04/2000	03/03/2000	
Arch/Eng Contract	04/24/2000	04/15/2001	07/06/2001
Schematic Design Approval	08/07/2000	10/15/2001	12/06/2001
Design Development Approval	10/02/2000	06/01/2002	03/28/2002
Construction Document Approval	12/11/2000	07/01/2002	
Bid Opening	01/15/2001	08/15/2002	
Award of Contracts	03/12/2001	10/15/2002	
Construction Start	03/13/2001	10/16/2002	
Report of Award to B/T	04/01/2001	11/01/2002	
Completion	02/04/2002	11/01/2003	

FUNDING INFORMATION:

Dev - James Cancer Hospital	4,940,000	7,339,702
Total	\$ 4,940,000	\$ 7,339,702

USES:

Construction	\$ 4,000,000	\$ 6,025,920
Contingency	552,000	726,247
Design	340,000	515,224
Univ Administration	48,000	72,311
Total	\$ 4,940,000	\$ 7,339,702

COMMENTS:

Project budget of \$4,940,000 approved by the Board of Trustees on March 3, 2000. The project has expanded to approximately 42,000 S.F. The 3rd floor addition will be a shelled space and the 4th floor will be a finished space. An elevator is also added to serves all levels including the two new floors.

Wiseman Hall - Expand Comprehensive Cancer Center

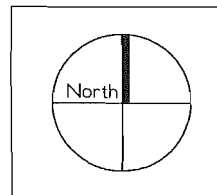
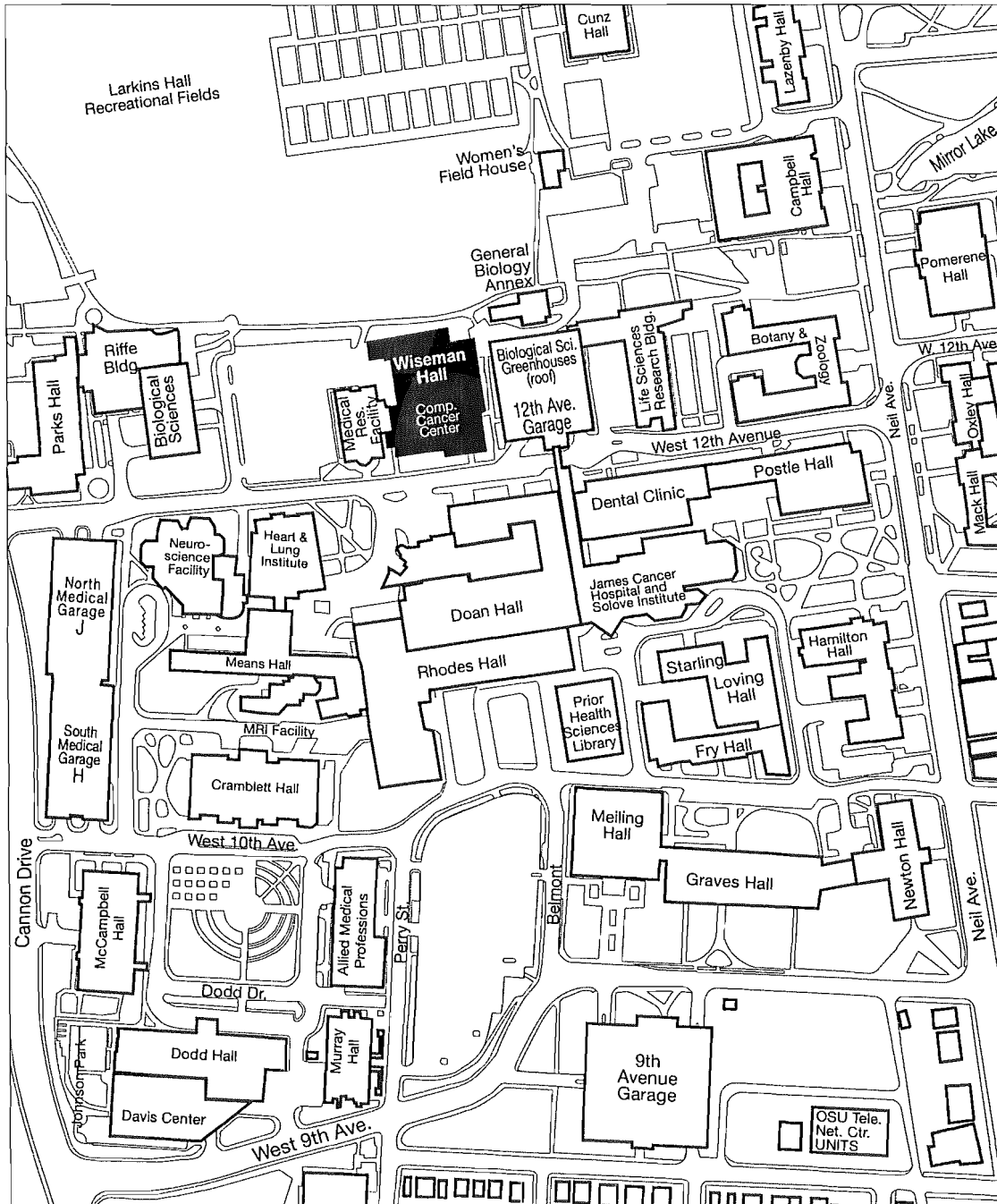

Office of Business and Finance
Office of Facilities Planning and Development

June 15, 2002

Student Family Community Center at Buckeye Village

315-1999-941

PROJECT CAPTAIN:

Ruth Miller, Facilities Planning & Development - Architecture, 292-4240

REQUESTING AGENCY:

Student Affairs

PROJECT LOCATION:

site - see comments

AGE:

N/A

GR. SQ. FT.:

N/A

PROJECT DESCRIPTION:

Construction of a new community facility to provide an integrated approach to addressing the needs of OSU Child Care Center and ACCESS Program for single parents and providing a new community facility at Buckeye Village. The new facility will provide space for administrative and maintenance offices, satellite child care center, recreation area, laundry facility, computer lab, aerobic fitness room, and meeting rooms.

MILESTONES:

	Projected	Revised	Actual
Arch/Eng Approved B/T	02/02/2001		02/02/2001
Bidding Approved B/T	02/02/2001	07/12/2002	
Arch/Eng Contract	07/01/2001	02/01/2002	02/01/2002
Schematic Design Approval	10/01/2001	02/14/2002	02/14/2002
Design Development Approval	02/15/2002		06/27/2002
Construction Document Approval	05/15/2002	08/29/2002	
Bid Opening	08/01/2002	11/07/2002	
Award of Contracts	10/01/2002	12/04/2002	
Construction Start	10/15/2002	12/06/2002	
Report of Award to B/T	11/01/2002	02/01/2003	
Completion	09/15/2003	01/15/2004	

FUNDING INFORMATION:

Future Univ Bonds	5,400,000		
Total	\$ 5,400,000	\$ -	

USES:

Construction	\$ 4,454,710	\$ 4,559,130	
Contingency	386,402	286,982	
Design	282,579	277,579	
Equipment	140,000	140,000	
Hazardous Material	85,064	85,064	
Univ Administration	51,245	51,245	
Total	\$ 5,400,000	\$ 5,400,000	

COMMENTS:

Student Family Community Center at Buckeye Village

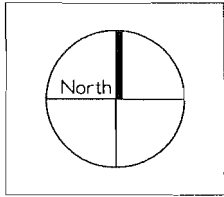
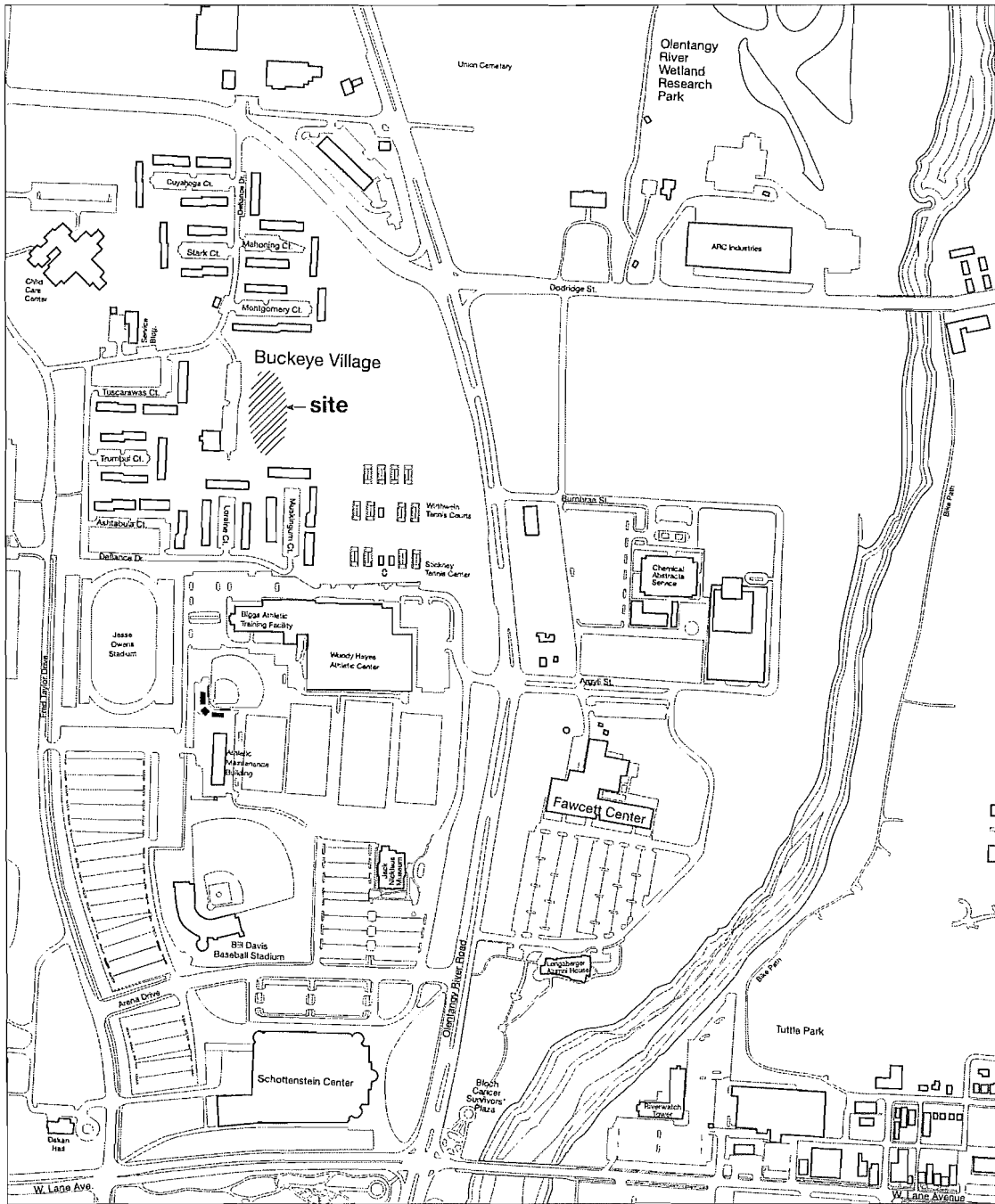

Office of Business and Finance
Office of Facilities Planning and Development

June 15, 2002

Medical Center - Central Sterile Supply Department

315-1999-939-4

PROJECT CAPTAIN:

Lori Seeger, Facilities Planning & Development - Architecture, 688-3757

REQUESTING AGENCY:

Health Sciences

PROJECT LOCATION:

site - see comments

AGE:

N/A

GR. SQ. FT.:

N/A

PROJECT DESCRIPTION:

Integration of a new Central Sterile Supply facility into the ground floor of the new Ross Heart Hospital.

MILESTONES:

	Projected	Revised	Actual
Arch/Eng Approved B/T	07/12/2002		
Construction Manager Approved B/T	07/12/2002		
Bidding Approved B/T	07/12/2002		
Arch/Eng Contract	07/15/2002		
Schematic Design Approval	07/15/2002		
Design Development Approval	07/15/2002		
Construction Document Approval	09/15/2002		
Bid Opening	11/01/2002		
Award of Contracts	01/01/2003		
Construction Start	01/10/2003		
Report of Award to B/T	03/01/2003		
Completion	01/01/2004		

FUNDING INFORMATION:

Aux - Univ. Hospitals	5,750,000		
Total	\$ 5,750,000	\$ -	

USES:

Construction	\$ 4,700,000		
Construction Manager	\$ 129,843		
Contingency	328,757		
Design	535,000		
Univ Administration	56,400		
Total	\$ 5,750,000	\$ -	

COMMENTS:

Medical Center - Central Sterile Supply Department

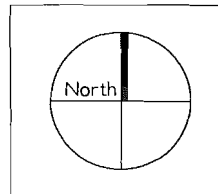
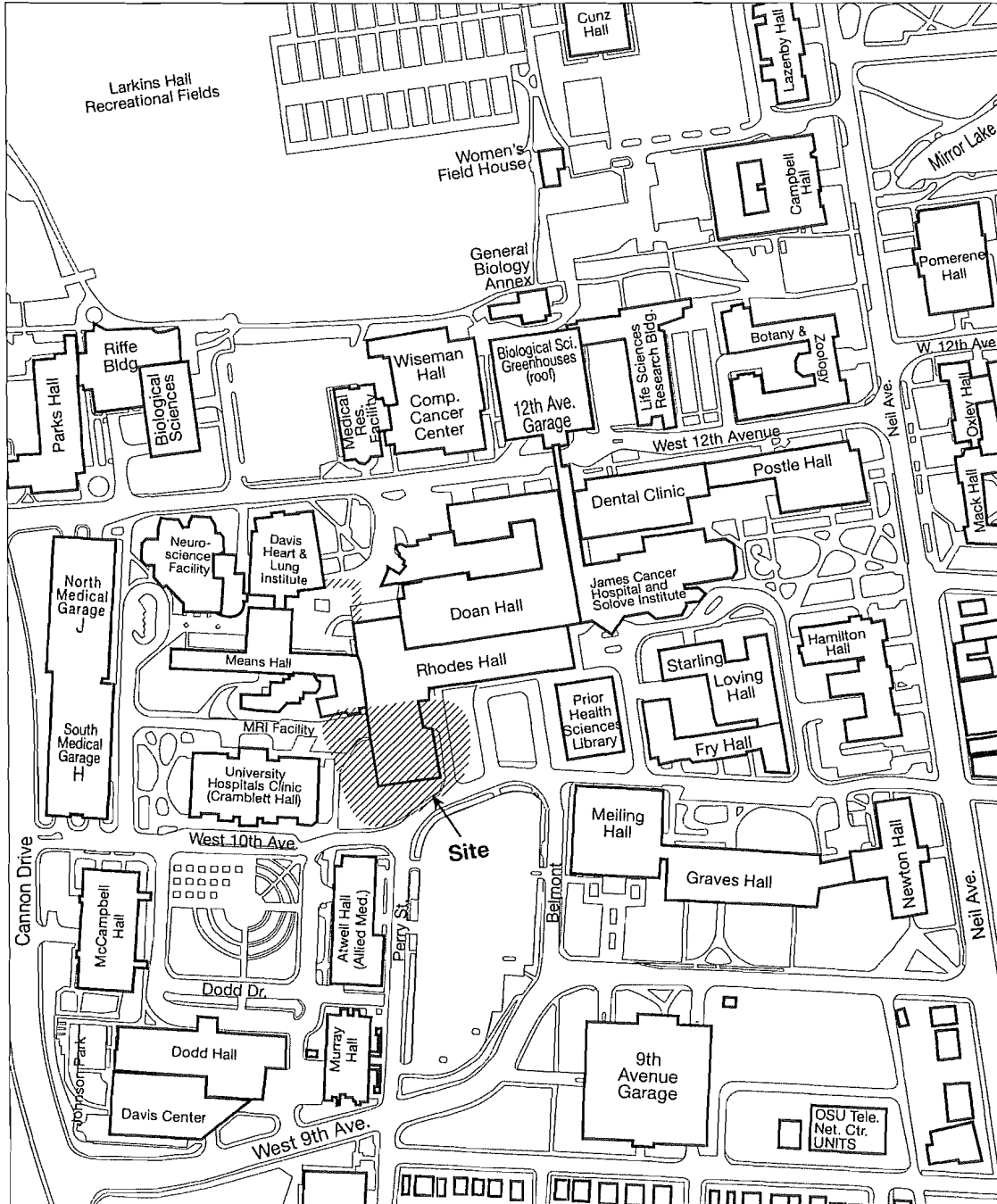

Office of Business and Finance
Office of Facilities Planning and Development

June 17, 2002

Medical Center - Helipad on Rhodes Hall

315-1999-939-3

PROJECT CAPTAIN:

Lori Seeger, Facilities Planning & Development - Architecture, 688-3757

REQUESTING AGENCY:

Health Sciences

PROJECT LOCATION:

site - see comments

AGE:

N/A

GR. SQ. FT.:

N/A

PROJECT DESCRIPTION:

Construct a 60' x 60' helipad on the southwest corner of Rhodes Hall Tower. Extend the two elevators from the Emergency department up to serve the helipad. Related renovations/relocations to accomodate construction.

MILESTONES:

	Projected	Revised	Actual
Arch/Eng Approved B/T	07/12/2002		
Construction Manager Approved B/T	07/12/2002		
Bidding Approved B/T	07/12/2002		
Arch/Eng Contract	07/15/2002		
Schematic Design Approval	07/15/2002		
Design Development Approval	07/15/2002		
Construction Document Approval	09/15/2002		
Bid Opening	11/01/2002		
Award of Contracts	01/01/2003		
Construction Start	01/10/2003		
Report of Award to B/T	03/01/2003		
Completion	01/01/2004		

FUNDING INFORMATION:

Aux - Univ. Hospitals	2,927,838		
Total	\$ 2,927,838	\$ -	

USES:

Construction	\$ 2,357,357		
Construction Manager	\$ 129,655		
Contingency	235,736		
Design	176,802		
Univ Administration	28,288		
Total	\$ 2,927,838	\$ -	

COMMENTS:

Contract for work will be integrated with Heart Hospital.

Medical Center - Helipad on Rhodes Hall

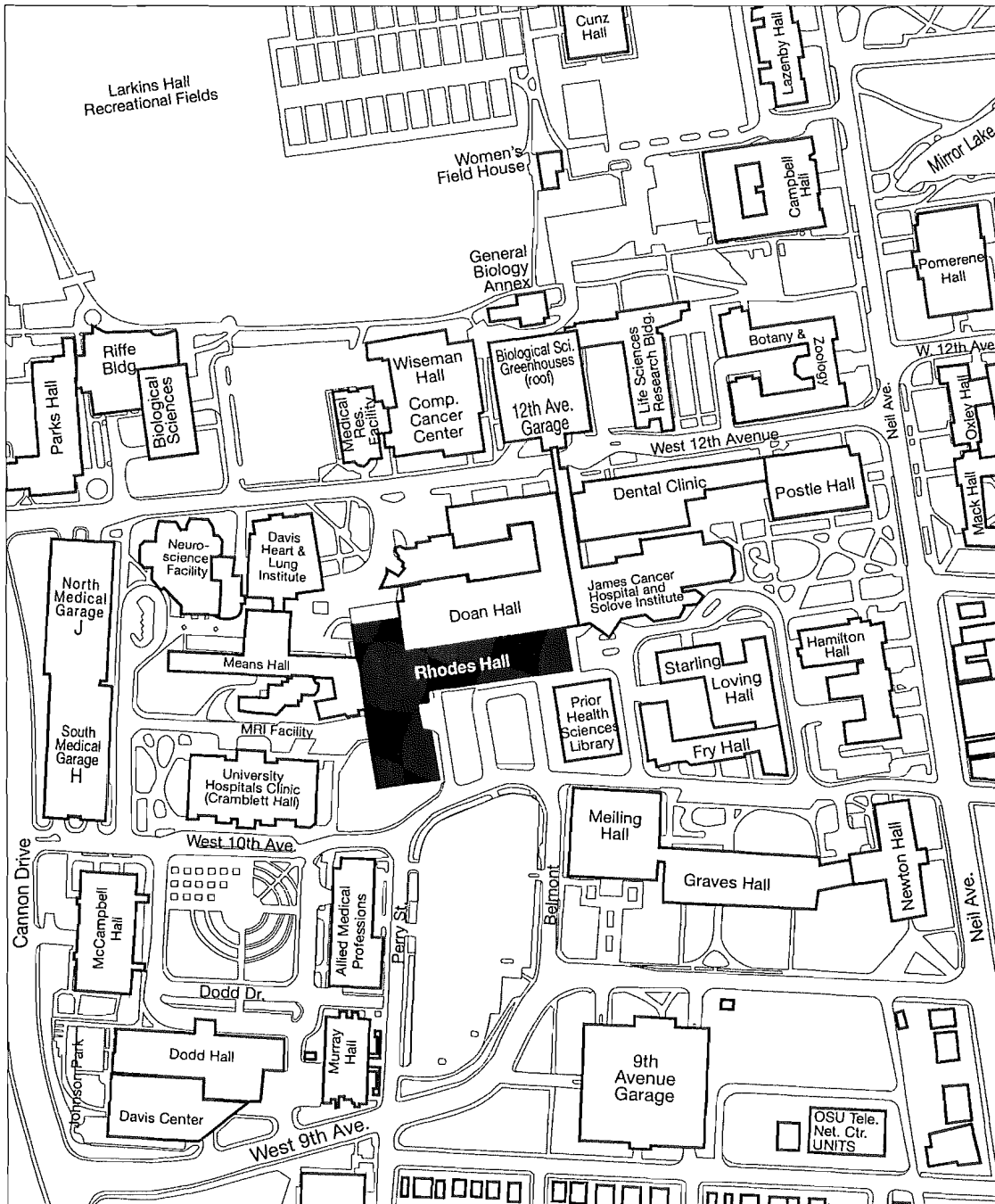

Office of Business and Finance
Office of Facilities Planning and Development

June 17, 2002

WOSU Renovation

315-2002-913

PROJECT CAPTAIN:

Ruth Miller, Facilities Planning & Development - Architecture, 292-4240

REQUESTING AGENCY:

WOSU Stations

PROJECT LOCATION:

0284 - FAWCETT CENTER FOR TOMORROW

AGE:

1970

GR. SQ. FT.:

178,207

PROJECT DESCRIPTION:

Renovate space in the Fawcett Center to create radio studios, a radio reception area, teleconference rooms, and space for digital transmission equipment.

MILESTONES:

	Projected	Revised	Actual
Arch/Eng Approved B/T	07/12/2002		
Bidding Approved B/T	07/12/2002		
Arch/Eng Contract	01/15/2003		
Schematic Design Approval	04/05/2003		
Design Development Approval	04/05/2003		
Construction Document Approval	06/05/2003		
Bid Opening	08/15/2003		
Award of Contracts	09/15/2003		
Construction Start	09/20/2003		
Report of Award to B/T	11/01/2003		
Completion	03/15/2004		

FUNDING INFORMATION:

WOSU		864,460		
Total	\$	864,460	\$	-

USES:

Construction	\$	705,682		
Contingency		70,568		
Design		77,625		
Univ Administration		10,585		
Total	\$	864,460	\$	-

COMMENTS:

WOSU Expansion

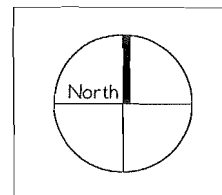
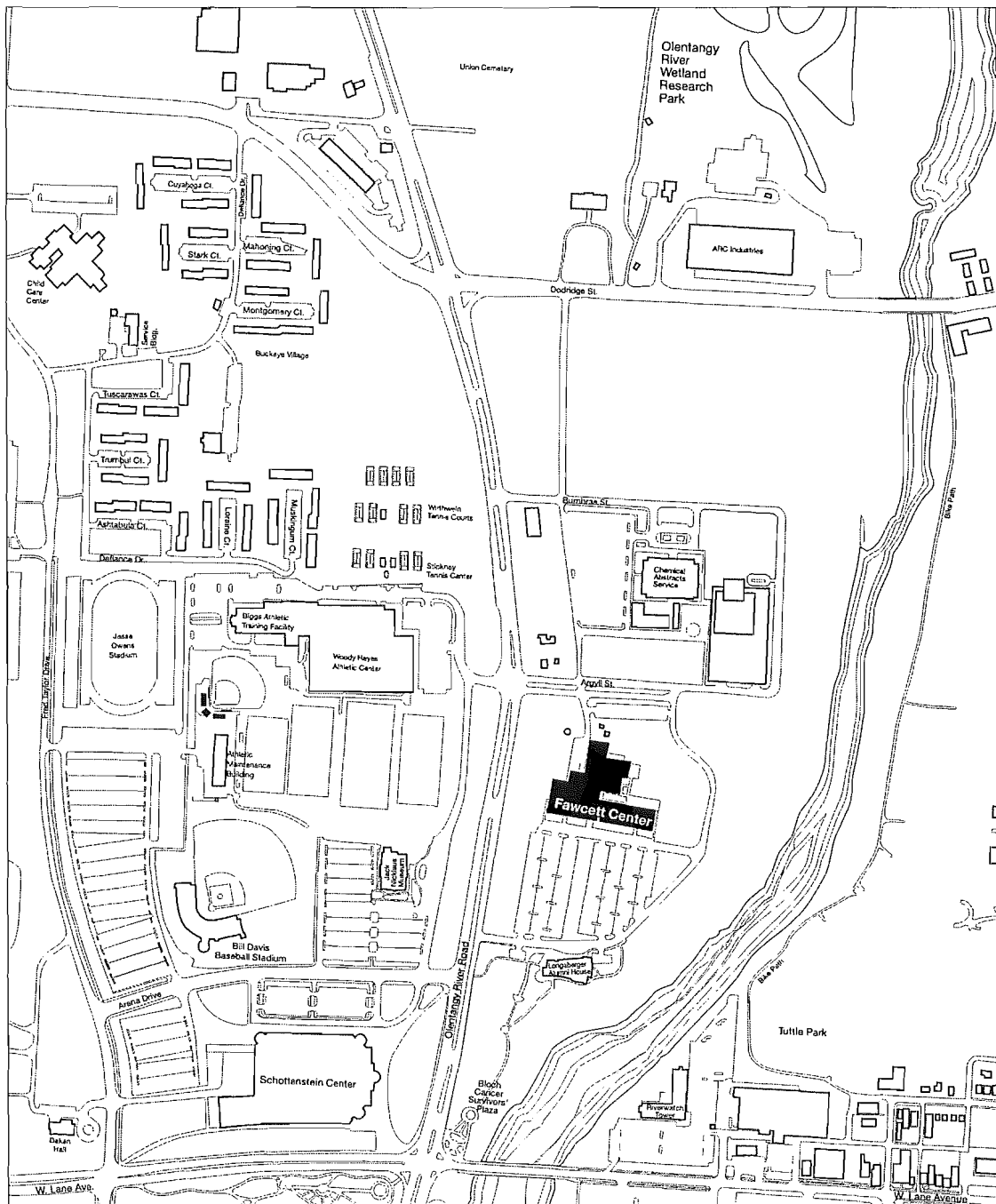

Office of Business and Finance
Office of Facilities Planning and Development

June 15, 2002

OARnet - HVAC and Electrical Improvements

315-2002-919

PROJECT CAPTAIN:

Colin McBride, University Engineer's Office - Physical Facilities, 292-7387

REQUESTING AGENCY:

OARnet

PROJECT LOCATION:

site - see comments

AGE:

N/A

GR. SQ. FT.:

N/A

PROJECT DESCRIPTION:

Install UPS system, generator, HVAC and new 3-phase 208-volt service at 1454 West Lane Avenue.

MILESTONES:

	Projected	Revised	Actual
Bidding Approved B/T	07/12/2002		
Schematic Design Approval	07/24/2002		
Design Development Approval	07/24/2002		
Construction Document Approval	07/24/2002		
Bid Opening	08/01/2002		
Award of Contracts	09/25/2002		
Construction Start	09/30/2002		
Report of Award to B/T	12/01/2002		
Completion	11/29/2002		

FUNDING INFORMATION:

House Bill 640	250,616		
Total	\$ 250,616	\$ -	

USES:

Construction	\$ 224,768		
Contingency	22,477		
Univ Administration	3,371		
Total	\$ 250,616	\$ -	

COMMENTS:

OARnet - HVAC and Electrical Improvements

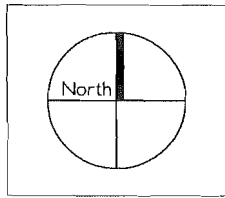
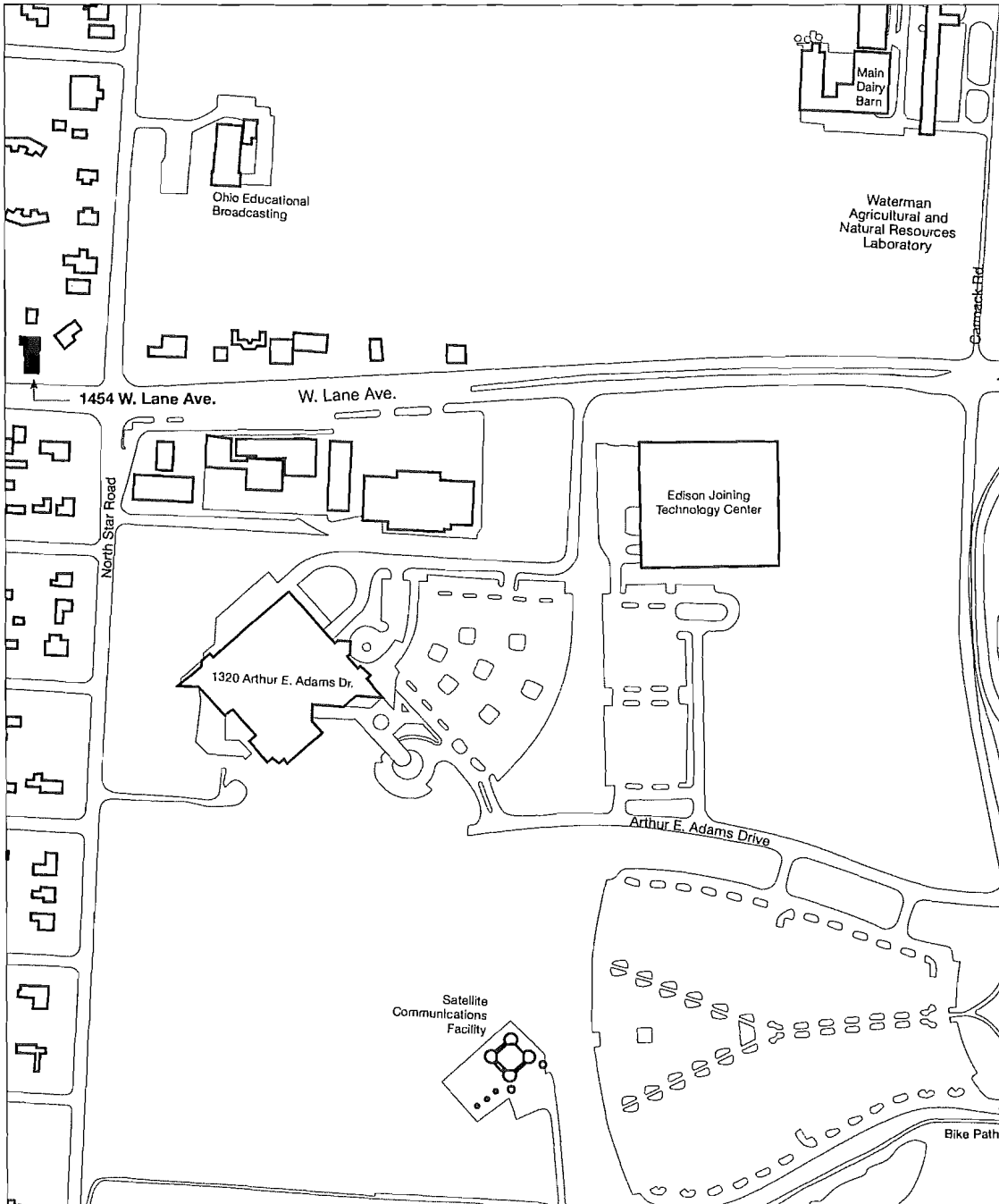

Office of Business and Finance
Office of Facilities Planning and Development

June 27, 2002

PROJECT CAPTAIN:

Scott Conlon, Facilities Planning & Development - Architecture, 292-0983

REQUESTING AGENCY:

Knowlton School of Architecture

PROJECT LOCATION:

site - see comments

AGE:

N/A

GR. SQ. FT.:

N/A

PROJECT DESCRIPTION:

Construct a new facility to house the programs of Architecture, City and Regional Planning, and Landscape Architecture.

MILESTONES:	Projected	Revised	Actual
Arch/Eng Approved B/T	11/04/1994		11/04/1994
Bidding Approved B/T	11/04/1994	11/01/1996	02/02/2001
Arch/Eng Contract			08/28/1999
Schematic Design Approval	09/08/1995	04/15/2000	04/17/2000
Design Development Approval	03/15/1996	11/15/2000	12/01/2000
Construction Document Approval	09/13/1996	08/30/2001	09/11/2001
Bid Opening	11/15/1996	04/03/2002	04/03/2002
Award of Contracts	02/14/1997	06/15/2002	06/21/2002
Construction Start	02/28/1997	06/21/2002	06/24/2002
Report of Award to B/T	03/07/1997	07/12/2002	
Completion	09/05/1998	04/14/2004	

FUNDING INFORMATION:

Dev - Engineering	\$ 10,000,000		
Future Capital Appropriations	\$ 9,000,000		
Future Univ Bond Proceeds		\$ 22,668,320	
House Bill 748	\$ -	\$ 233,280	
House Bill 790	\$ 1,000,000	\$ 1,000,000	
House Bill 850	\$ -	\$ 9,000,000	
Dept. of Physical Facilities	-	98,400	
Total	\$ 20,000,000	\$ 33,000,000	

USES:

Columns	\$ 1,000,000	\$ 810,532	
Construction	\$ 16,000,000	\$ 25,639,800	
Contingency	1,500,000	1,937,170	
Design	1,500,000	2,075,596	
Equipment		1,666,833	
Estimating Consultant		137,197	
Moving	-	50,000	
Percent for Art		90,000	
State Architect	-	77,769	
Swing Space *		157,500	
Telecommunication Line Reloc		110,500	
Univ Administration	-	247,103	
Total	\$ 20,000,000	\$ 33,000,000	

COMMENTS:

Authorization to bid originally received November 1, 1996. Authorization to bid at the higher, revised project budget received February 2, 2001. Additional budget increases reflect the acceptance of alternates at the time of receipt of bids, the inclusion of the marble cladding on the building, and library revisions.

Previously known as project number 315-1998-039.

The Knowlton columns (5) were installed Summer/Fall 1998 adjacent to Tuttle Park Place on the future site of the Knowlton School of Architecture.

Project budget increased to more closely reflect the scope of the work. Debt service on the University bonds will be paid through gifts to the School.

The existing project budget does not include funding for asbestos abatement of Ives Hall. This work is being accomplished via project contingency funds.

* Swing space costs total \$305,000 of which \$157,500 is funded from Knowlton School of Architecture and \$157,500 from Central University funds. (See project 50700-R011648 Vivian Hall Rooms 1-218)

Knowlton School of Architecture

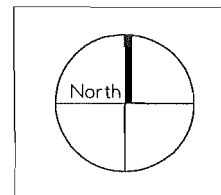
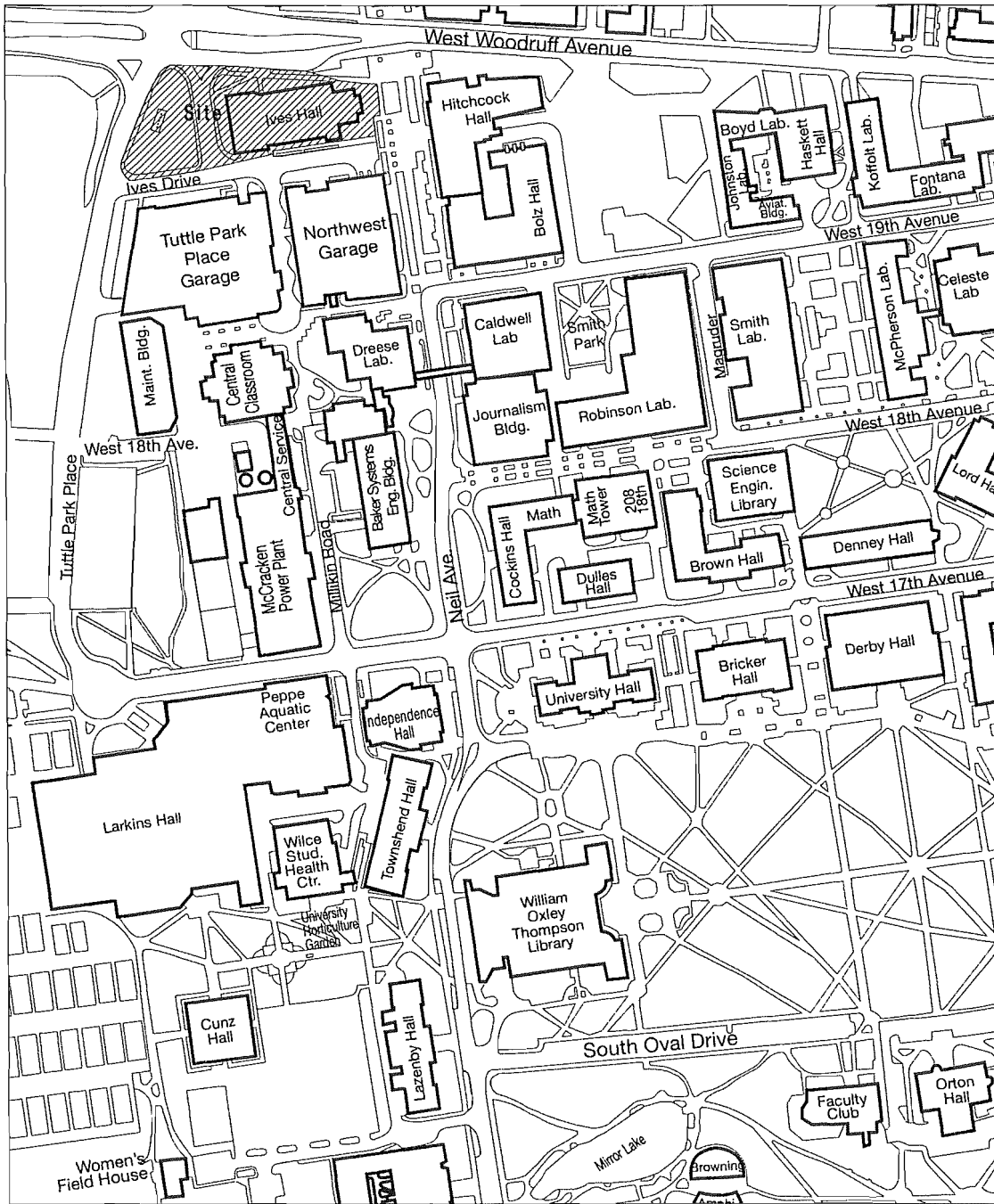

Office of Business and Finance
Office of Facilities Planning and Development

June 20, 2002

PROJECT CAPTAIN:

Chuck Hamilton, Facilities Planning & Development - Architecture, 292-0997

REQUESTING AGENCY:

Newark Campus

PROJECT LOCATION:

site - see comments

AGE:

N/A

GR. SQ. FT.:

N/A

PROJECT DESCRIPTION:

Construct an instructional technology center to support the academic mission, provide student gathering/activity spaces, and serve as a conference center for the community.

MILESTONES:

	Projected	Revised	Actual
Arch/Eng Approved B/T	10/01/1999		10/01/1999
Bidding Approved B/T	12/03/2000	11/02/2001	11/02/2001
Arch/Eng Contract	01/01/2000		06/20/2000
Schematic Design Approval	06/01/2000	01/31/2001	01/31/2001
Design Development Approval	09/01/2000	05/31/2001	05/31/2001
Construction Document Approval	03/01/2001	12/20/2001	01/04/2002
Bid Opening	04/01/2001	02/27/2002	02/27/2002
Award of Contracts	06/15/2001	04/28/2002	04/25/2002
Construction Start	07/01/2001	04/22/2002	04/29/2002
Report of Award to B/T	06/01/2001	07/12/2002	
Completion	12/31/2002	08/22/2003	

FUNDING INFORMATION:

Central Ohio Technical College	\$	2,266,530	\$	2,266,530
Dev - Newark Campus	\$	7,623,000	\$	8,158,515
Future Capital Appropriations		3,445,050		3,445,050
Total	\$	13,334,580	\$	13,870,095

USES:

Construction	\$	11,234,441	\$	10,581,788
Contingency		561,722		774,995
Design		986,741		986,741
Equipment		500,000		500,000
Technology		-		900,000
Univ Administration		51,676		126,571
Total	\$	13,334,580	\$	13,870,095

COMMENTS:

Site is east of LeFevre Hall. Project budget increased to reflect the inclusion of technology equipment not included in the original project budget.

Newark Campus - Reese Center

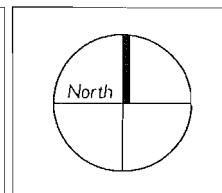
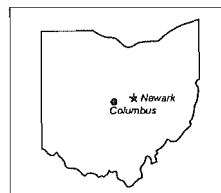
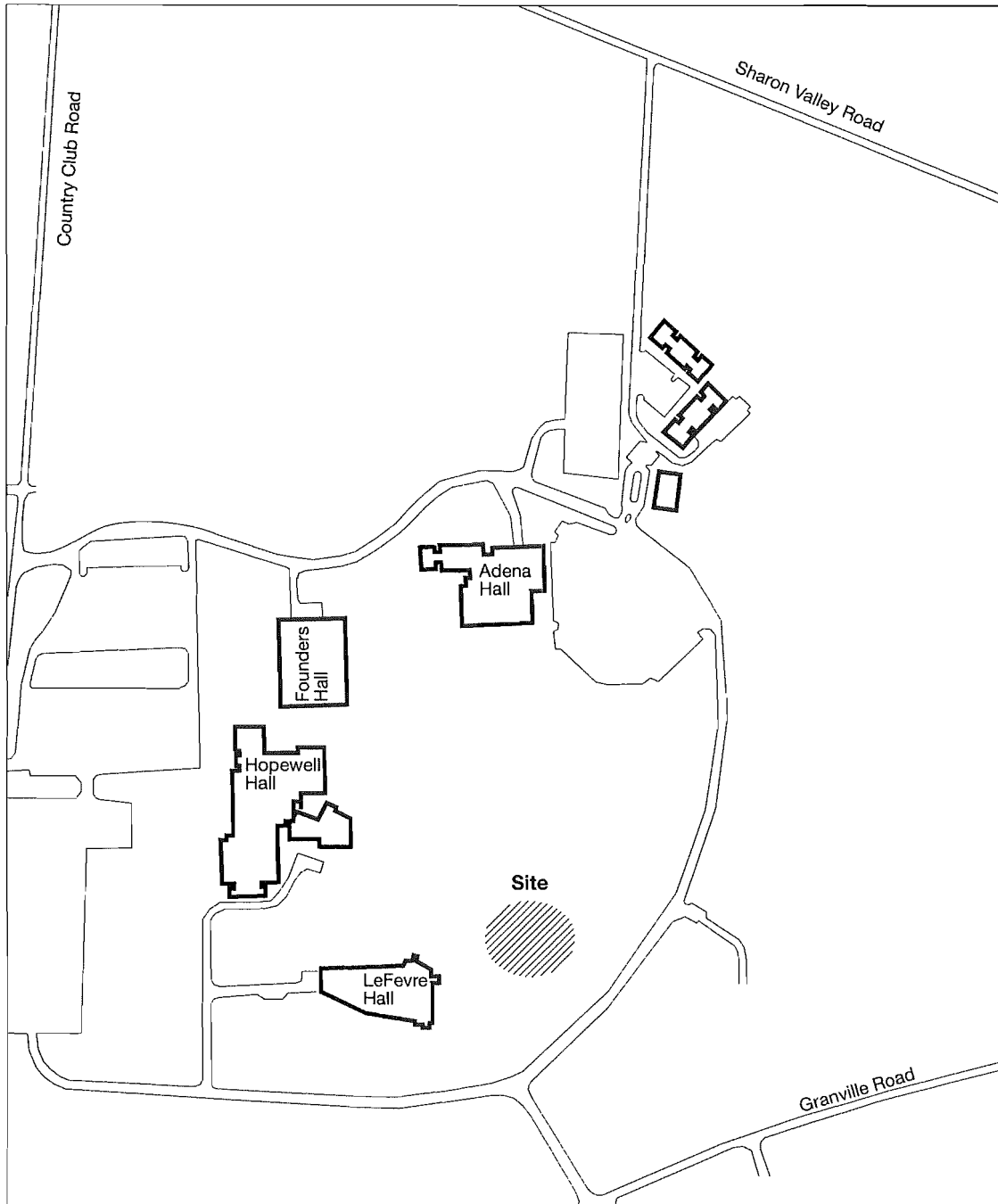

Office of Business and Finance
Office of Facilities Planning and Development

October 10, 2001

Automated Transport System for Univ Medical Center Phase I

315-2000-900

PROJECT CAPTAIN:

Chuck Hamilton, Facilities Planning & Development - Architecture, 292-0997

REQUESTING AGENCY:

University Hospitals

PROJECT LOCATION:

site - see comments

AGE:

N/A

GR. SQ. FT.:

N/A

PROJECT DESCRIPTION:

Renovations associated with the replacement of an automated material handling system.

MILESTONES:	Projected	Revised	Actual
Arch/Eng Approved B/T	12/03/1999		12/03/1999
Bidding Approved B/T	12/03/1999		11/02/2001
Arch/Eng Contract	03/14/2001		03/19/2001
Construction Document Approval	07/01/2000	01/10/2002	10/10/2001
Bid Opening	08/01/2000	02/06/2002	03/05/2002
Award of Contracts	08/31/2000	04/15/2002	04/10/2002
Construction Start	09/01/2000	04/15/2002	04/22/2002
Report of Award to B/T	12/01/2000	07/12/2002	
Completion	09/01/2002	12/16/2002	

FUNDING INFORMATION:

Aux - University Hospitals	950,000	4,187,175
Total	\$ 950,000	\$ 4,187,175

USES:

Construction	\$ 800,000	\$ 2,962,786
Contingency	53,750	496,939
Design	85,000	691,897
Univ Administration	11,250	35,553
Total	\$ 950,000	\$ 4,187,175

COMMENTS:

Increased project budget and scope presented to the Board of Trustees for approval on 6/29/01 and 11/2/01 and reflect a change in scope of services, including expansion of the system to all areas of the Medical Center.

Cramblett Hall - OB/GYN Clinic

315-1999-943

PROJECT CAPTAIN:

Patrick Cuthbert, Facilities Planning & Development - Architecture, 292-3186

REQUESTING AGENCY:

University Hospitals

PROJECT LOCATION:

0300 - CRAMBLETT HALL

AGE:

1974

GR. SQ. FT.:

225,849

PROJECT DESCRIPTION:

Renovate approximately 17,000 gross square feet of space located on the second floor of Cramblett Hall in order to expand the OB/GYN Clinic area.

MILESTONES:

	Projected	Revised	Actual
Arch/Eng Approved B/T	04/02/1999		04/06/1999
Bidding Approved B/T	04/02/1999		02/04/2000
Schematic Design Document Approval	05/15/1999		12/01/1999
Design Dev Document Approval	06/01/1999		02/01/2000
Construction Document Approval	07/15/1999		05/15/2000
Bid Opening	08/31/1999	02/22/2002	03/01/2002
Award of Contracts	09/15/1999	07/02/2002	
Construction Start	10/01/1999	07/08/2002	
Report of Award to B/T	12/01/1999	07/12/2002	
Completion	03/31/2000	01/07/2003	

FUNDING INFORMATION:

Aux - University Hospitals	914,000	1,821,025
Total	\$ 914,000	\$ 1,821,025

USES:

Construction	\$ 760,750	\$ 1,395,659
Contingency	60,000	206,075
Design	82,000	202,672
Univ Administration	11,250	16,619
Total	\$ 914,000	\$ 1,821,025

COMMENTS:

Project budget increased to reflect the scope change of additional square feet and complete demolition of walls and doors in lieu of using existing. Board of Trustees approval of the revised scope and project budget received 2/4/00.

Cramblett Hall - OB/GYN Clinic

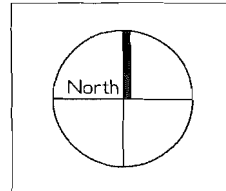
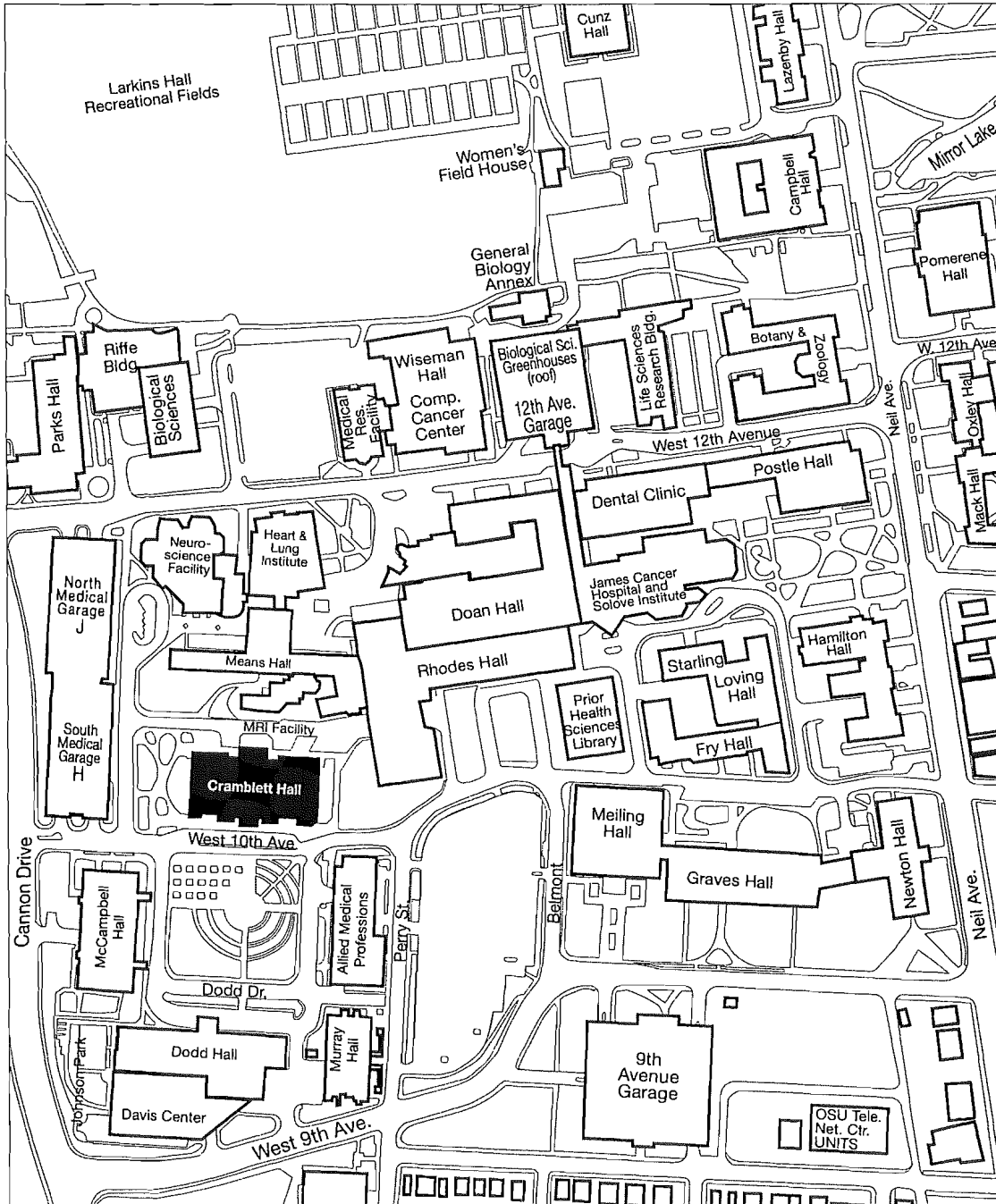

Office of Business and Finance
Office of Facilities Planning and Development

December 9, 2000

Campus Grounds - Woody Hayes Drive Rebuild

315-2000-934

PROJECT CAPTAIN:

Tricia Petras, University Engineer - Physical Facilities, 292-1349

REQUESTING AGENCY:

Physical Facilities

PROJECT LOCATION:

Unidentified Bridge/Roadway

AGE:

N/A

GR. SQ. FT.:

N/A

PROJECT DESCRIPTION:

The section of road between Herrick Drive and Kenny Road will be rebuilt to carry bus traffic. Many sections have failed due to heavy vehicles and improper drainage.

MILESTONES:

	Projected	Revised	Actual
Arch/Eng Approved B/T	08/30/2000		08/30/2000
Bidding Approved B/T	08/30/2000		08/30/2000
Schematic Design Document Approval	08/01/2001	04/01/2002	04/01/2002
Design Dev Document Approval	11/01/2001	04/01/2002	04/01/2002
Construction Document Approval	02/01/2002	07/01/2002	04/01/2002
Bid Opening	04/01/2002	06/15/2002	05/01/2002
Award of Contracts	06/01/2002	07/01/2002	06/17/2002
Construction Start	06/15/2002	07/01/2002	06/17/2002
Report of Award to B/T	07/01/2002	07/12/2002	
Completion	09/01/2002	08/16/2002	

FUNDING INFORMATION:

House Bill 640		1,500,000		1,214,012
Total	\$	1,500,000	\$	1,214,012

USES:

Construction	\$	1,275,000	\$	973,091
Contingency		116,625		97,309
Design		89,250		129,016
Univ Administration		19,125		14,596
Total	\$	1,500,000	\$	1,214,012

COMMENTS:

Campus Grounds Woody Hayes Drive Rebuild

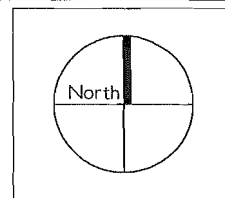
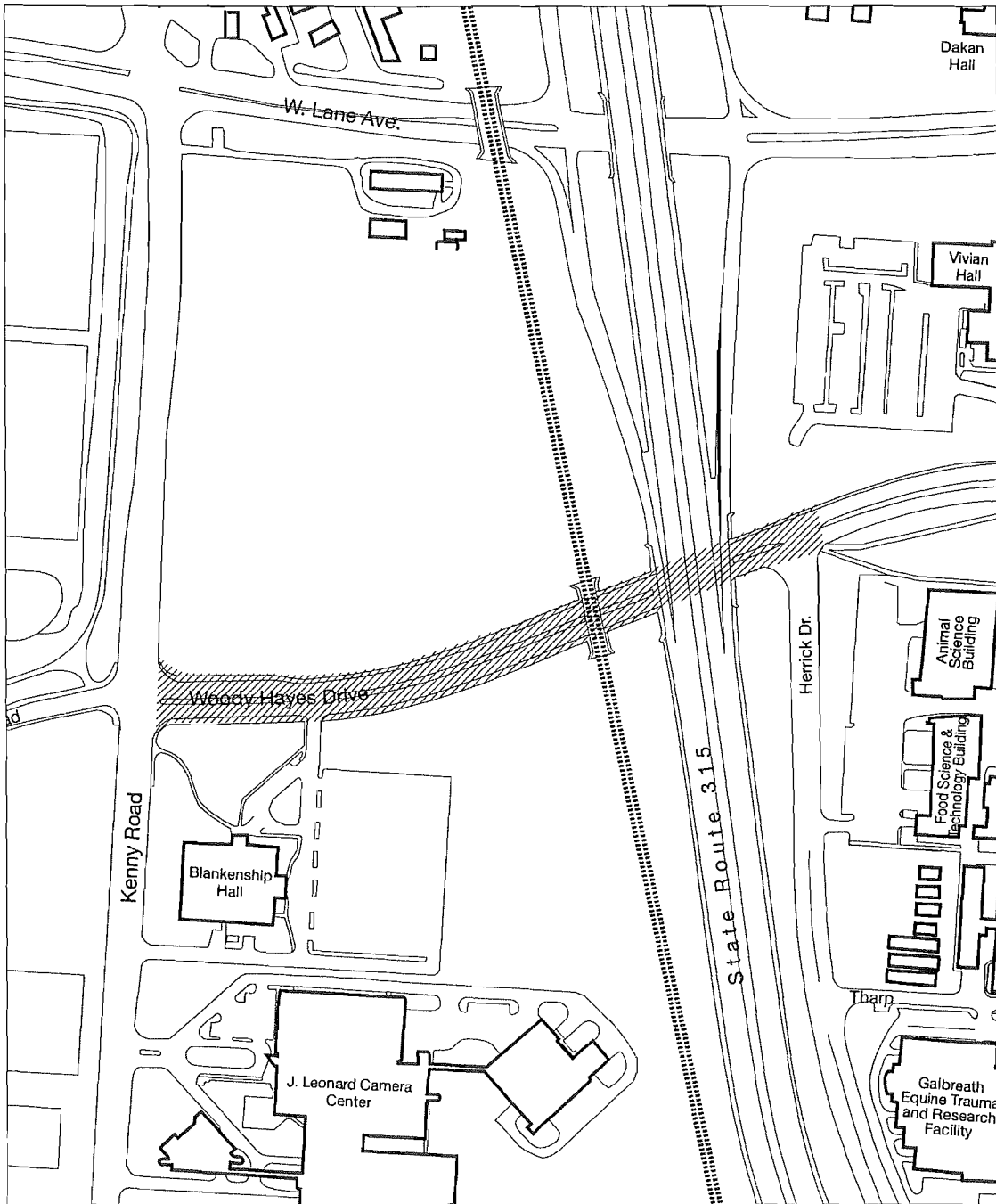

Office of Business and Finance
Office of Facilities Planning and Development

December 9, 2000

(APPENDIX II)

PURCHASE OF REAL PROPERTY

**4.3 ACRES ADJACENT TO THE MARION CAMPUS
MARION, OHIO**

Location and Description

The property to be purchased consists of 4.3 acres of unimproved woodland adjacent to the northwestern corner of The Ohio State University's Marion Campus. It is directly south of the Early Childcare Center, which has frontage on State Route 95 (Mount Vernon Avenue). The only access to the property would be through the adjoining University property; it is not served by other access roads.

Appraisal and Purchase Price

A 1999 MAI appraisal conducted by Blue Appraisal Company was updated in the fall of 2001 and valued the property to be purchased at \$65,000. The property owners, who hold the land in a trust, will transfer the land to the University for that price. The deed to the property will be transferred and conveyed by Lawrence Babich and Carl Fry as Trustees through Karen Seckel, the Executor of the Estate of James C. Neff. Acquisition expenses will be about \$3,000. The Marion Campus will be responsible for the costs for the purchase and operation of the property.

Use of the Property

Title to the property will be taken in the name of the State of Ohio for the use and benefit of The Ohio State University. Ownership of this parcel will give the University greater control of development on the western border of the Marion Campus, where the County plans a connector road that is expected to result in commercial and retail growth. The Marion Campus master plan currently under development identifies purchase of this property as a long-term goal.

Purchase of Real Property 4.3 Acres adjacent to The Ohio State University Marion Campus

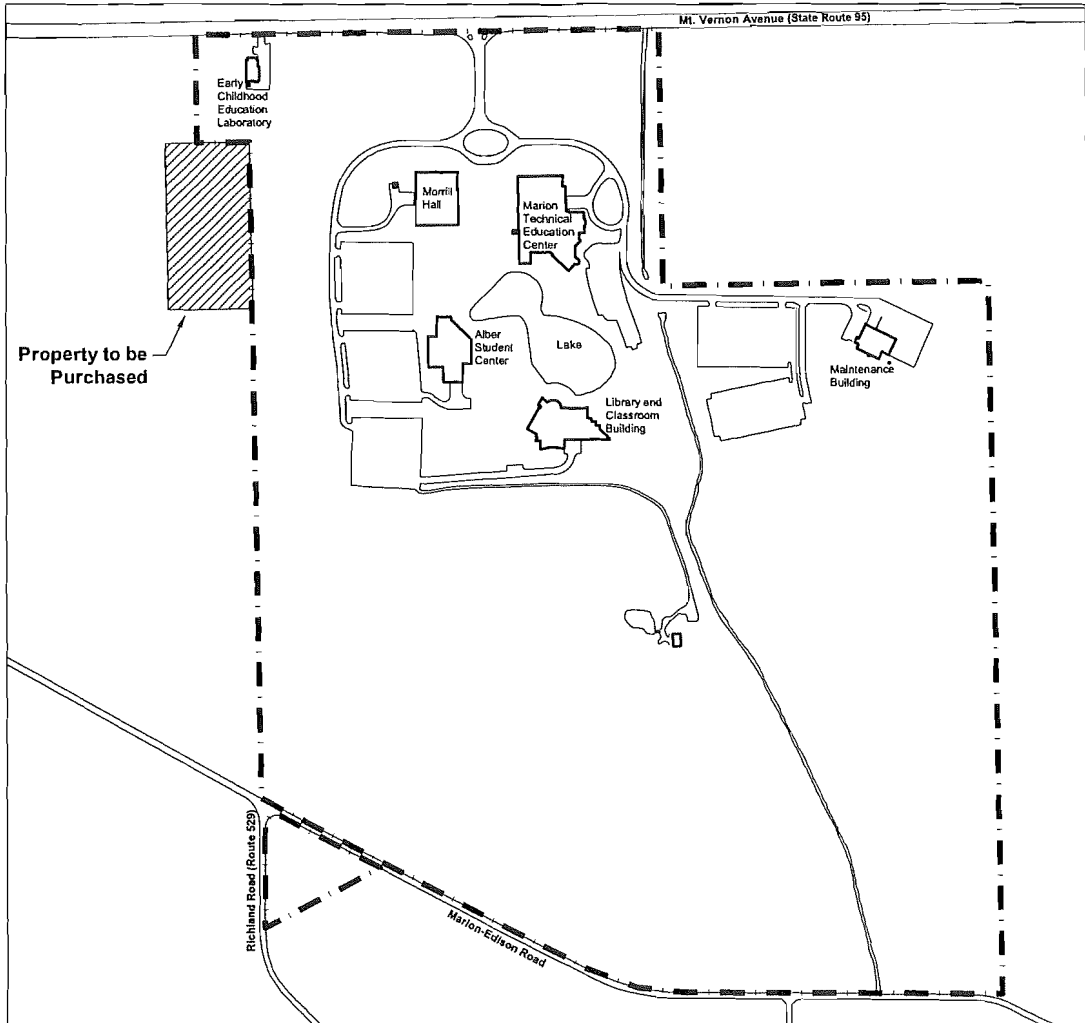

No True Scale

Office of Business and Finance
July 12, 2002



 Property to be Purchased

Map Provided by University Engineer's Office

 Boundary of OSU Marion Campus

(APPENDIX III)

ACQUISITION OF LEASEHOLD INTEREST

COMMERCIAL AND RESIDENTIAL PROPERTY
1656-1660 NEIL AVENUE
COLUMBUS, OHIO

Location and Description

The leasehold interest to be purchased consists of 0.12 acres of commercially zoned property held in a perpetual lease by Campus Partners. The leasehold contains a commercial and residential building that houses a McDonald's Restaurant and two apartment units upstairs. The underlying fee simple title is held by the State of Ohio for the use of The Ohio State University, bequeathed to the University in 1992 by Mabel White. Control of the land, though, is through the perpetual lease, which belonged to the estate of the late Dr. Frank Long and was purchased from the estate by Campus Partners in 2000. At that time, the University and Campus Partners contemplated this subsequent transfer of this leasehold interest to the University. Rent from the land lease is \$2,000 per year; rent from the leasehold improvements is approximately \$43,700 per year.

Appraisal and Purchase Price

MAI appraisals conducted by Anthony F. Mollica & Associates in 2000 and by Affiliated Appraisers of America in 2002 valued the property at \$480,000 and \$528,000, respectively. Campus Partners will sell the property for \$500,000. Internal University costs of due diligence and related fees for this purchase will total another \$20,000. Funds for the purchase costs will be provided through the Land Purchase Account.

Use of the Property

The property will continue in its current use. The property is within the South Campus Acquisition Area, and purchase of the leasehold interest, which gives the University control of the property, is in accordance with the goals of the Master Plan.

Proposed Purchase of Leasehold Interest In Real Property 1656-60 Neil Avenue

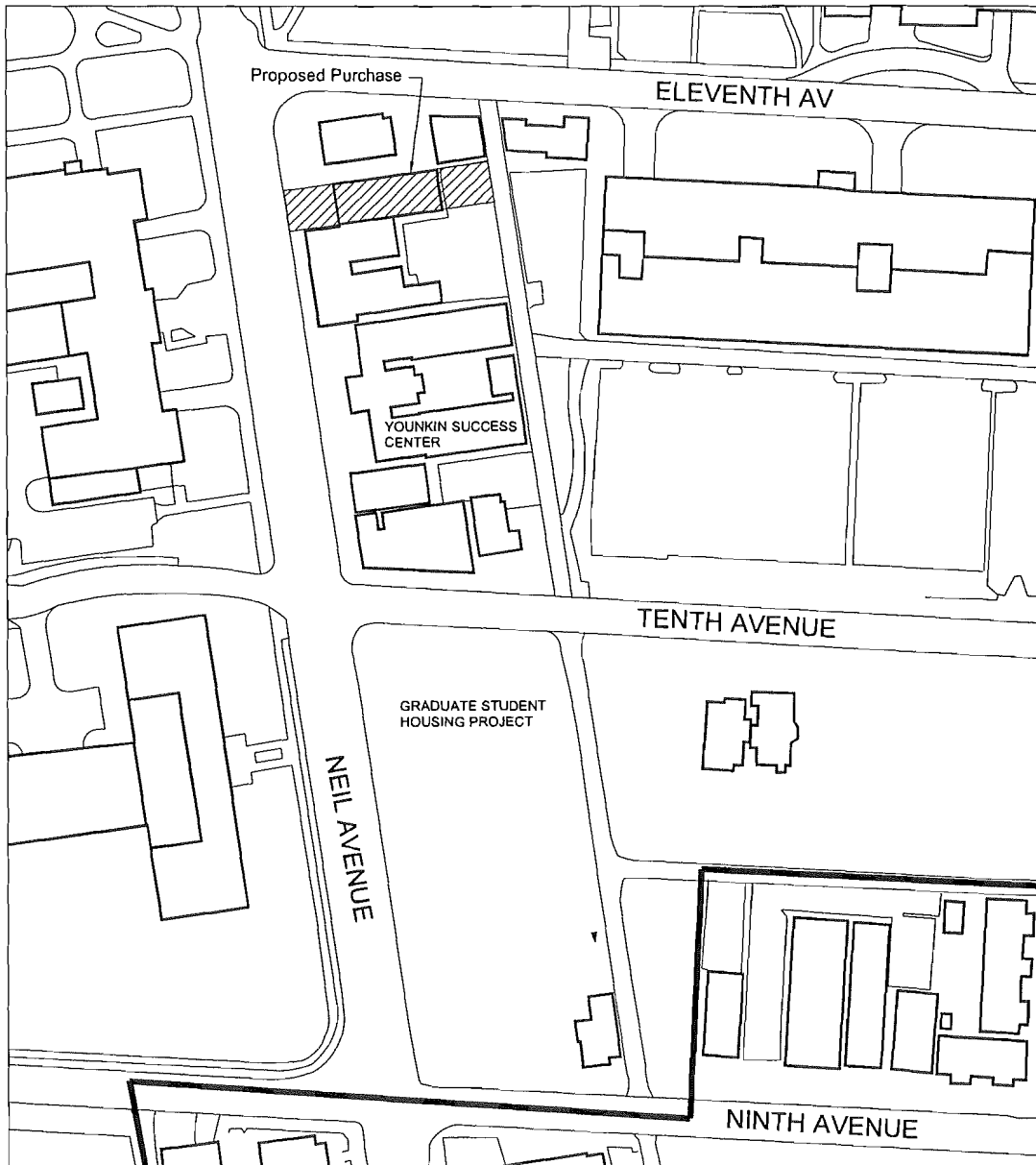



No True Scale

Office of Business and Finance
July 12, 2002



Map Provided by University Engineer's Office

-  Proposed Purchase of Leasehold Interest in Real Property
-  Southern Boundary of South Campus Acquisition Area

Purchase of Leasehold Interest 1440 Hawthorne Avenue

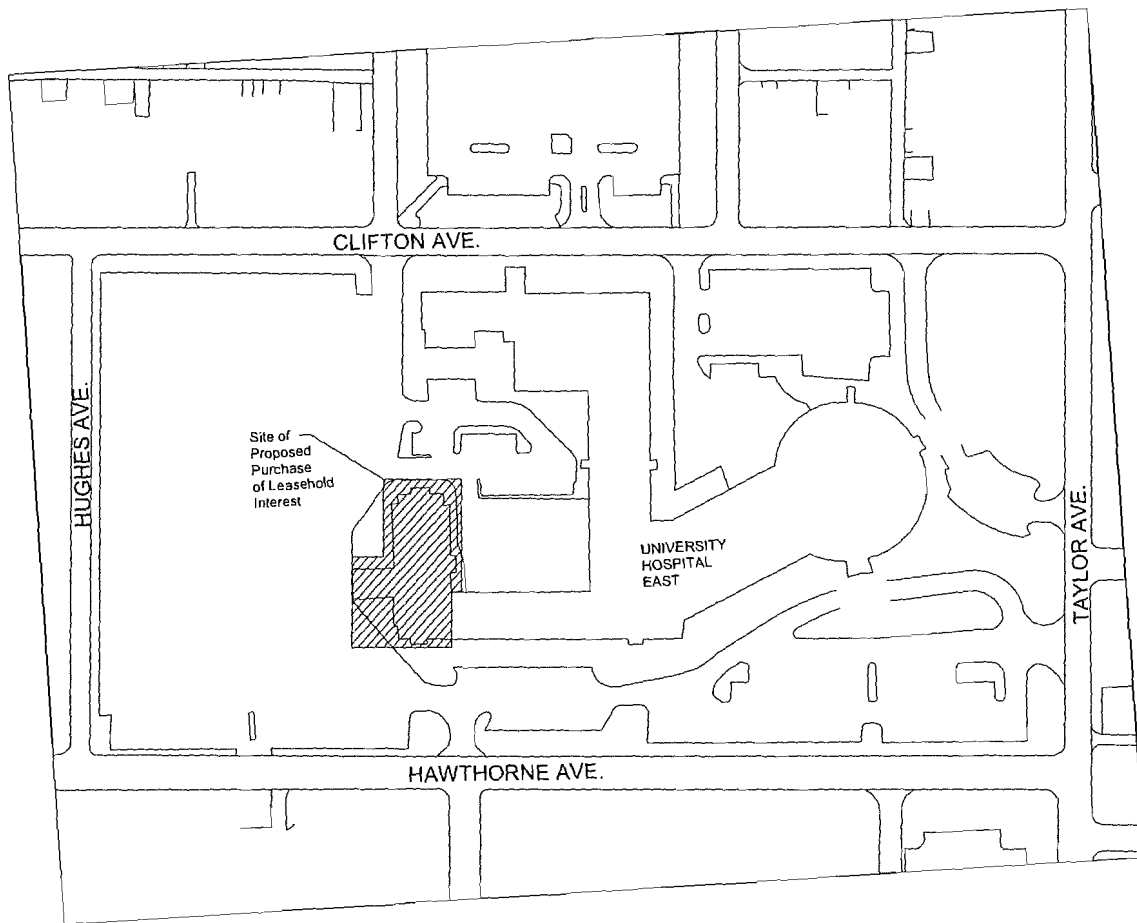

No True Scale



Map Provided by University Engineer's Office

Office of Business and Finance
July 12, 2002

 Site of Proposed Purchase of Leasehold Interest

(APPENDIX V)

CONSTRUCTION EASEMENT

**ARSHOT INVESTMENT CORPORATION
UNIMPROVED PROPERTY AT UNIVERSITY AIRPORT**

The Arshot Investment Corporation has requested a temporary construction easement across a 21.25 acre parcel of University land titled in the State of Ohio for the use of The Ohio State University, located at the eastern edge of the University Airport, for construction and installation of storm and sanitary sewer improvements.

Arshot will be responsible for all costs of construction and installation of the storm and sanitary sewer improvements and for any damages suffered by the University as a result of the construction and installation. The consideration for the easement shall be a nominal sum of one dollar.

Once constructed, the storm and sanitary sewer improvements will be accepted by the City of Columbus as "a public sewer improvement," pursuant to easements to the City of Columbus as provided in the resolution that follows this one.

Grant of Temporary Easement To Arshot Investment Corporation Adjacent to University Airport

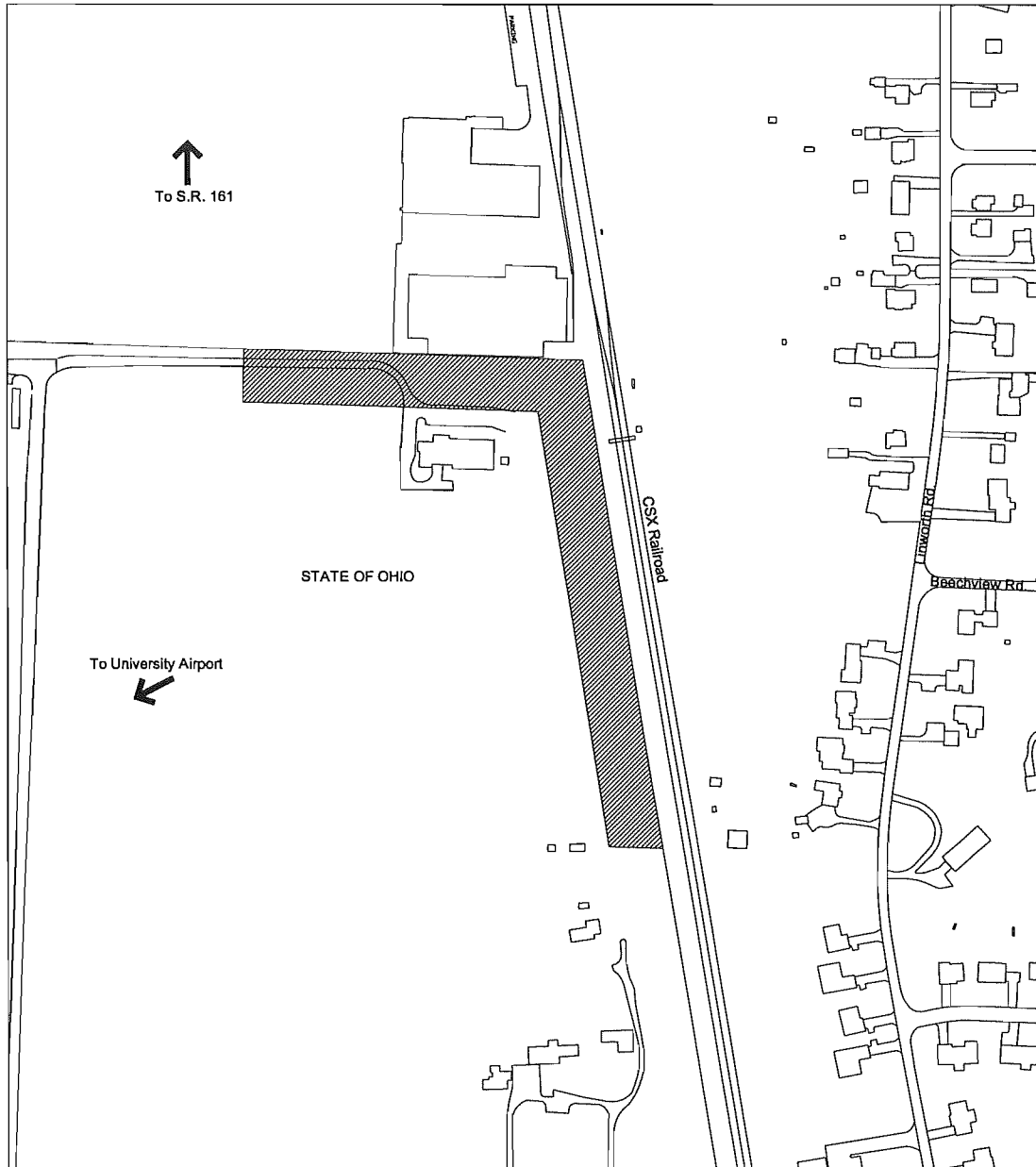

No True Scale

Office of Business and Finance
July 12, 2002



 Proposed Temporary
Construction Easement

Map Provided by University Engineer's Office

(APPENDIX VI)

SANITARY AND STORM SEWER EASEMENT

CITY OF COLUMBUS
UNIMPROVED PROPERTY AT UNIVERSITY AIRPORT

The City of Columbus has requested two easements (one for operation, maintenance, and repair of a sanitary sewer line and the other for a storm sewer line) across a 21.25 acre parcel of University land titled in the State of Ohio for the use of The Ohio State University, located at the eastern edge of the University Airport. These are the sewer line improvements to be constructed by the Arshot Investment Corporation pursuant to the previous resolution.

In each case, Columbus has requested a perpetual easement, which the University would propose to grant if the University receives the necessary authority to do so from the Ohio Department of Administrative Services and the General Assembly. If such authorization is not provided, the term of each easement would be for 25 years once each sewer line is accepted by the City. The consideration for the easement shall be a nominal sum of one dollar. The City will be responsible for all costs of operation, maintenance, and repair of the sewer lines and for any damages suffered by the University as a result of the operations.

Grant of Easement To City of Columbus Adjacent To University Airport

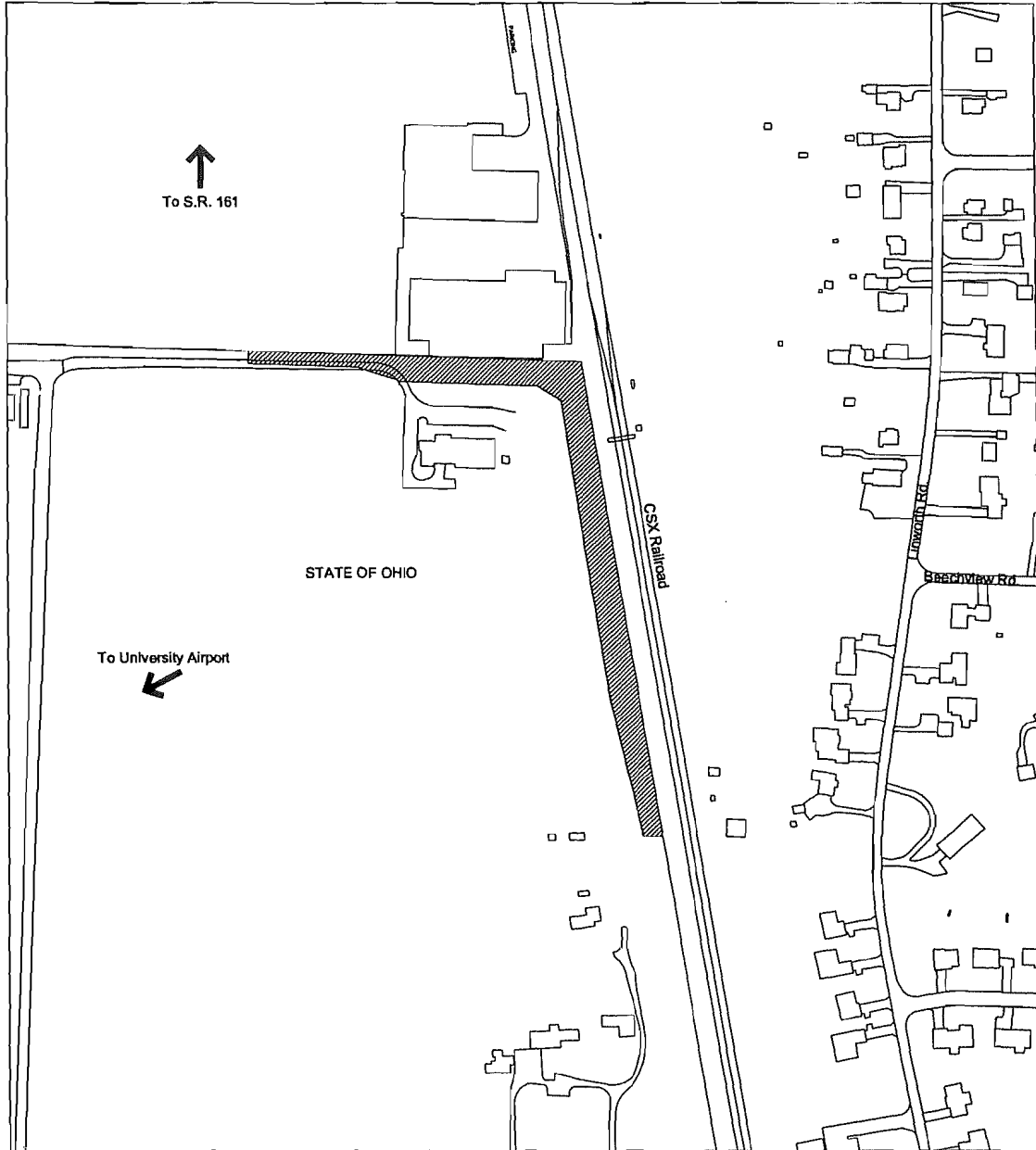

No True Scale

Office of Business and Finance
July 12, 2002



Map Provided by University Engineer's Office

 Proposed Storm and Sanitary Sewer Easement

(APPENDIX VII)

HIGHWAY EASEMENT

OHIO DEPARTMENT OF TRANSPORTATION
UNIMPROVED PROPERTY WEST OF THE OLENTANGY RIVER
FOR RAMPS CONNECTING TO STATE ROUTE 315

The Ohio Department of Transportation is requesting a perpetual highway easement across approximately 4.5 acres of unimproved University land west of the Olentangy River, north of King Avenue, and south of Herrick Drive for construction and operation of a partial interchange between State Route 315 and Cannon Drive. The highway improvements will consist of a northbound State Route 315 exit ramp to Cannon Drive at the intersection of 9th Avenue and a southbound entrance ramp from Cannon Drive at the intersection of 12th Avenue. In addition, appropriate lighting, traffic control, traffic signals, signing, drainage and retaining walls are to be provided, and a portion of the existing bike path also will be relocated. This easement will be granted pursuant to the provisions of Ohio Revised Code Section 3335.11, which provides that the University, on behalf of the State, may grant highway easements to ODOT.

S.R. 315 Ramps Easements to Ohio Department of Transportation

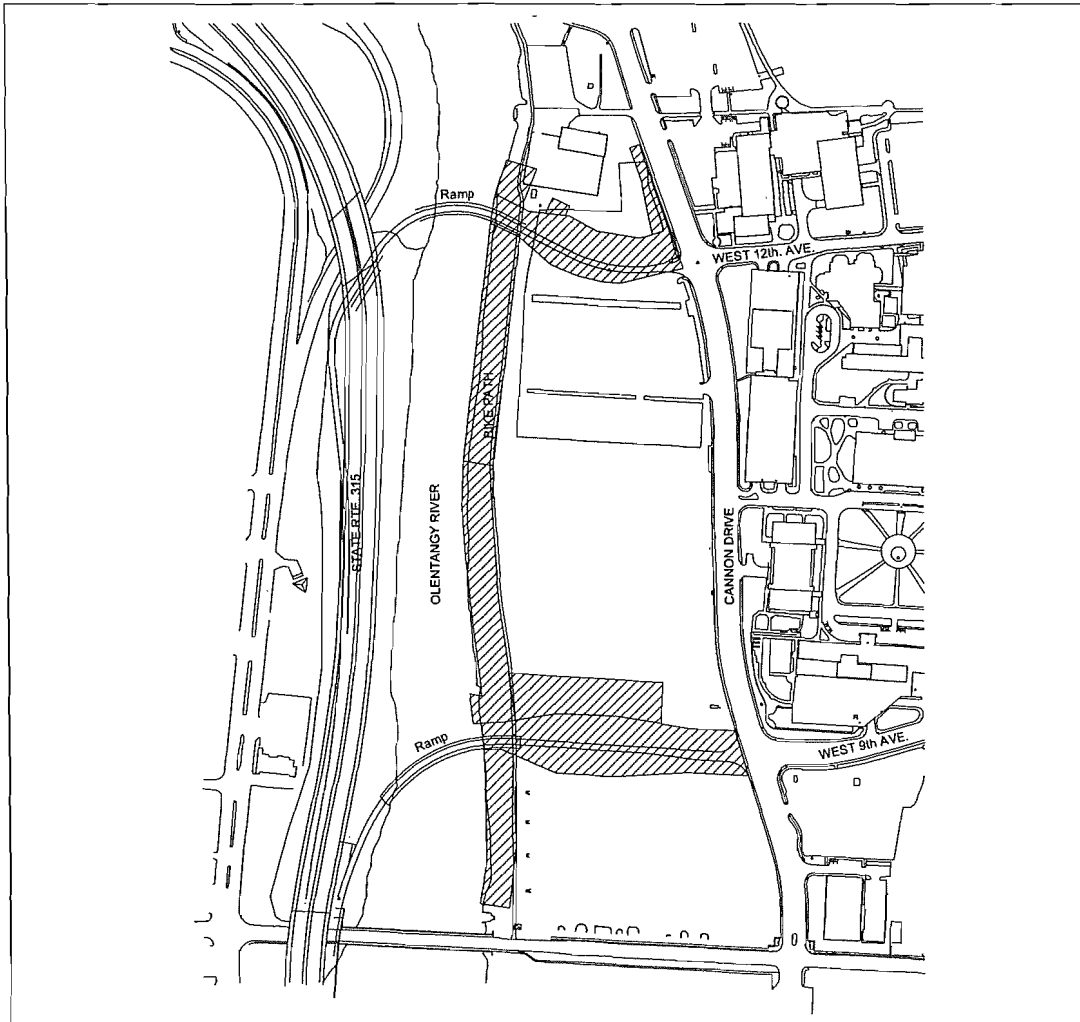

No True Scale



Office of Business and Finance

July 12, 2002

Map Provided by University Engineer's Office



Proposed Easement

DRAFT

07/12/02



Project Summary

For

The Ohio State University Medical Center

- The Ohio State University Health System

Construction Program

Richard M. Ross Heart Hospital

July 2002

Overview

Throughout the nation, health systems are developing specialty focused inpatient hospitals and ambulatory facilities to improve patient care efficiency, cost-effectiveness and customer service. These reasons, combined with OSUMC's needs to support its academic mission, provide a broad rationale for pursuit of this complex endeavor.

OSUMC began its evaluation of a focused cardiovascular hospital in 1997. In that year a strategic review of the cardiovascular services market throughout a 40 county region of Central Ohio was begun. Throughout 1998 and most of 1999 a further market assessment, along with a very general facility study, were completed. In early 2000, these initiatives led to a recommendation to The Ohio State University Trustees who authorized the pursuit of the development of a heart hospital on an accelerated timetable.

Consequently, in 2001, OSUMC proceeded with the design and development of an architecturally distinct heart hospital, connected with University Hospital/Rhodes Hall. This state-of-the-art facility, The Richard M. Ross Heart Hospital, will place OSUMC among a small group of elite academic medical centers that seek to distinguish themselves with a synergistic combination of leading edge clinical and research programs, thus forming a world-class cardiovascular enterprise unmatched in the United States.

Strategic Objectives

The key objectives of the heart hospital development are as follows:

1. To enhance the academic stature of OSUMC's cardiovascular program – The development of this state-of-the-art facility will enable the provision of the most current and sophisticated cardiovascular care, thus attracting top-tier clinical faculty and enhancing the medical center's teaching programs.
2. To provide a clinical laboratory for cutting edge research programs that are conducted in the Davis Heart & Lung Research Institute - The new hospital will facilitate the translation of basic science and clinical research from the laboratory to the bedside.
3. To enable the provision of a more efficient clinical model – Current cardiovascular services are fragmented within University Hospital and do not lend themselves to the most efficient delivery of patient care. By contrast, the Ross Heart Hospital is being designed with the specific intention of providing patient care in the most cost-effective and efficient manner possible.
4. To realize the value potential of the cardiovascular product line – The development of the Ross Heart Hospital and the achievement of its financial objectives will produce cash flows that can be re-invested in the clinical operations of the OSU Health System, to the benefit of the medical center's academic mission.

Measurements of Success

Academic:

In accordance with the University's Academic Plan and the stated goal of becoming one of the top public research institutions in the nation, OSUMC's strategic focus is as follows:

Be among the top quartile of academic medical centers in each mission area by 2008 as measured using nationally accepted metrics.

The metrics for each mission area are:

Research: NIH rankings of annual awards; US News and World Report rankings

Education: US News and World Report rankings (medical schools); graduate programs; residency programs

Clinical: US News and World Report rankings (best hospitals and specialty areas); HCIA top 100 hospitals.

Therefore, the development of the Ross Heart Hospital should affect OSUMC's mission areas in the following manner:

- Bolster the translational research effort of the Davis Heart & Lung Research Institute;
- Contribute to the enhancement of teaching programs within the College of Medicine and Public Health and their elevation in national rankings; and
- Enhance the national stature of The OSU Health System's clinical programs in general, and the cardiovascular program in particular.

Growth in Clinical Faculty:

Over the next five fiscal years, each of the three clinical divisions must increase the number of clinical faculty as follows:

	<u>Current Faculty</u>	<u>Proposed Faculty</u>
Cardiology	28	54
Cardiothoracic Surgery	2	7
Vascular Surgery	4	5

Operating Interdependencies:

Specific strategies and tactics are being developed to ensure that the many operating components of The OSU Health System, clinical enterprise, and business strategies combine to produce positive financial results.

Physician Component

- Stability in leadership of Cardiology Division
- Cardiology success in recruiting new Division staff
- Achieving growth in Cardiology and CT Surgery procedures
- Increasing heart transplant program / volumes

Corporate Services

- Favorable managed care negotiations
- Management of indirect costs and service levels from Corporate Services
- Aggressive price negotiations with vendors of drugs, supplies, devices

Patient Care Services

- Achieve staffing targets per transition of clinical model

Ross Heart Hospital Project Cost

The chart on the following page shows the uses and sources of funds to develop the Ross Heart Hospital. The total project cost is \$82,800,000. Interest during construction is \$2,695,350 and financing costs are projected to be \$1,000,000.

Borrowing of \$66,595,350 will be the principal source of funds for the project. The OSU Health System will contribute \$8,300,000 and State funding is shown at \$2,600,000. Fundraising will occur in two stages: (a) \$10 million must be raised and collected by the end of the construction period; and (b) an additional \$20 million must be raised over the first seven years of heart hospital operation. A Heart Center Fund-Raising Committee has been established and early efforts have been very successful.

Overall, the Ross Heart Hospital will be approximately 200,000 square feet in size. It will be four stories in height. Patient care services will include 100 beds (90 nursing and 10 short-stay/recovery), 6 operating rooms, 6 cath/interventional suites, an outpatient clinic with 20 exam rooms and 7 consult rooms, comprehensive non-invasive diagnostics, and capacity for advanced cardiac imaging.

Sources and Uses of Funds

Project Cost	
Building	\$ 66,600,000
Equipment	16,200,000
Total Project	82,800,000
Net Interest cost during Construction	2,695,350
Total Depreciable Cost	\$ 85,495,350
Uses and Sources of Funds	
Uses	
Construction, Equipment and Soft Costs	\$ 82,800,000
Interest During Construction	2,695,350
Financing Costs (3.0%)	1,000,000
Total	\$ 86,495,350
Sources	
Fundraising (during construction)(1)	\$ 10,000,000
Borrowing	65,595,350
State Funding	2,600,000
OSUH Contribution	8,300,000
Total	\$ 86,495,350
Borrowing:	
Long-term debt incurred 6/1//2004	
Term of loan repayment is 20 years	
Interest Rate is 5.50% including parking surcharge	
Interest During Construction Borrowed for 30 months utilizing commercial paper	
(1) An additional \$20 million will be raised during the first seven years of hospital operation.	

Project Timeline

A summary of the project timeline is shown below. Through the efforts of The OSU Health System, the University Office of Facilities Planning and Development, and the Office of Resource Planning and Institutional Analysis, an accelerated schedule has been prepared.

	<u>Start of Activity</u>	<u>Completion of Activity</u>
Schematic Design:	July 2001	January 2002
Design Development:	October 2001	April 2002
Construction Documents:	May 2002	October 2002
Preparation Phase:	February 2002	September 2002
Site Utilities:	June 2002	November 2002
Excavation, Foundations, Construction:	July 2002	May 2004
Occupancy:		June 2004

DRAFT

07/12/02



Project Summary

For

The Ohio State University Medical Center

- College of Medicine and Public Health
- Office of Health Sciences

Biomedical Research Tower

July 2002

Overview

Today in medicine we are seeing the dawn of a new era in biomedical discovery and knowledge that will revolutionize the diagnosis, treatment and prevention of human disease in the coming decades. We will be able to offer customized treatment (and ultimately, prevention) of some of the most devastating illnesses of our time such as cancer and cardiovascular, infectious and neurological diseases.

The most important medical discoveries, and the best new doctors and scientists, now come from institutions that can generate the newest, highest-quality research and technology and keep pace with new knowledge in all disciplines, all over the world. Furthermore, cities and states throughout the U.S. are moving boldly to build economic strength in biotechnology and biomedical discovery and application.

As a comprehensive institution with many disciplines and facilities available for developing powerful research collaborations and expanding the pace and quality of new knowledge, The Ohio State University (OSU) has a tremendous opportunity to use its resources to benefit the people of Ohio and beyond. With the addition of this research facility we can position the University at the forefront of biomedical research and technology.

Strategic Objectives

The goal of the Biomedical Research Tower (BRT) is to create a multidisciplinary biomedical research and education center for The Ohio State University Medical Center (OSUMC) that will be a centerpiece of a dramatically enhanced health sciences campus. Integral to the University's Academic Plan for becoming a top public research institution, BRT will greatly advance the academic missions, the international reputations and the financial status of the OSUMC and the University while bringing enormous value in health care, advanced technology, and economic growth to the State of Ohio and its citizens.

Excellence, in OSU's core missions of research and education, will bring important value-added components to the University and OSUMC. The experience of top universities and medical centers nationally confirms that excellent facilities attract excellent faculty and students and promote the kind of achievement and innovation that bring enormous returns. Our institutional commitment to biomedical research will result in dramatic enhancements in extramural research funding, attraction of outstanding faculty and students, fundraising, collaboration with industry, entrepreneurial opportunities, national and international reputation, and leading edge patient care.

This project will contribute substantially to the fulfillment of many of the goals of the Academic Plan. Excellent facilities and programs, which provide interdisciplinary opportunities, are critical in the recruitment and retention of top tier researchers, teachers, and clinicians. Facilities such as the BRT are necessary to continue the Strategic Investment approach by competitively funding initiatives that build programmatic strength and open new fields. With the advanced facilities that will be available, we will maintain ongoing multidisciplinary initiatives where appropriate and develop new initiatives that draw on University-wide strengths, which create new multidisciplinary centers that can attract additional faculty in key areas. Finally, entrepreneurial opportunities resulting from growth

in biomedical research and technology will bring money and jobs to Ohio. These opportunities will advance the Academic Plan's goals:

- *Building a world-class faculty – concentrating in areas of strategic focus.*
- *Developing academic programs that define Ohio State as the nation's leading public land-grant university.*

- *Enhancing the quality of the teaching and learning environment.*
- *Enhancing and better serving the student body, creating a diverse university community.*
- *Helping build Ohio's future.*

Measurements of Success

Success of the facility's design and development will be measured in terms of its ability to accommodate and enhance the following research initiatives: Molecular Neurobiology & Neurodegenerative Disorders, Molecular Medicine & Pharmacogenomics, Transplantation & Tissue Engineering, Structural Biology & Imaging, Microbial Pathogenesis, Biomedical Informatics, Heart and Lung, Experimental Therapeutics, and Diabetes.

Success in terms of productivity will be measured by the number of people trained and the impact of this training on their career success, the number of graduate students, the amount of extramural support, the number and quality of publications, the number of patents achieved, the licensing of technologies based on discoveries made in the new facility, and eventually, the returns from such technology transfer activities.

Outcomes of BRT for the OSUMC and University will include greatly increased extramural research funding, the attraction of outstanding faculty and students, increased fundraising, collaboration with industry, entrepreneurial opportunities, national and international reputation, and leading edge patient care.

Project Cost

As detailed on the following page, the total initial project construction cost is estimated to be approximately \$120.3M plus approximately \$6.9M of interest costs during construction. The \$120.3M refers to the initial construction only. The cost for the whole project after build-out is completed is approximately \$151.8M. The facility will be approximately 420,000gsf (247,000asf), of which approximately 175,000asf would be completed in the initial project budget, with four floors of shelled space which will provide an additional 72,000asf of space when built-out as needed in subsequent years. The cost of the future build-out is projected to be approximately \$11.9M for 36,000asf if completed in 2008 and approximately \$12.8M for the remaining 36,000asf if completed in 2010. The assignable square feet to gross square feet ratio will be a minimum of 57%.

BRT Sources and Uses of Construction Funds

USES OF FUNDS		
Initial Project Costs (8-01-01 thru 12-31-06)		
Construction Costs	\$ 87,767,019	
Design Fees	\$ 7,021,361	
Construction Management Fees	\$ 4,827,186	
OSU Facilities Planning & Development Fees	\$ 1,228,738	
Moveable Fixtures, Furnishings, & Equipment	\$ 7,172,452	
Construction, Commissioning, & Risk Management Contingencies	\$ 12,287,383	
Total Initial Project Construction Costs	\$ 120,304,139	
Interest Costs During Initial Construction	\$ 6,868,233	
Total Initial Project Costs		\$ 127,172,372
Build-Out 66,000 gsf Shelled Floors (2007 mid-point Construction)		
Construction Costs	\$ 9,125,493	
Design Fees	\$ 821,294	
OSU Facilities Planning & Development Fees	\$ 127,757	
Moveable Fixtures, Furnishings, & Equipment	\$ 912,549	
Construction Contingencies	\$ 912,549	
Total Build-Out Costs of 66,000 gsf Shelled Floors		\$ 11,899,642
Build-Out 66,000 gsf Shelled Floors (2009 mid-point Construction)		
Construction Costs	\$ 9,775,458	
Design Fees	\$ 879,791	
OSU Facilities Planning & Development Fees	\$ 136,856	
Moveable Fixtures, Furnishings, & Equipment	\$ 977,546	
Construction Contingencies	\$ 977,546	
Total Build-Out Costs of 66,000 gsf Shelled Floors		\$ 12,747,197
TOTAL USES OF FUNDS		\$ 151,819,211
SOURCES OF FUNDS		
Sources for Initial Project Costs (8-01-01 thru 12-31-06)		
Development Funds (20% of Initial Project Costs)	24,060,828	
Sources for Interest Costs During Construction (see Cash Flow on Page 7)	\$ 6,868,233	
Bonds to be Sold for Initial Project in 2006	\$ 96,243,311	
Total Sources for Initial Project Costs		\$ 127,172,372
Sources for Build-Out 66,000 gsf Shelled Floors		
Bonds to be Sold in 2008		\$ 11,899,643
Sources for Build-Out 66,000 gsf Shelled Floors		
Bonds to be Sold in 2010		\$ 12,747,197
TOTAL SOURCES OF FUNDS		\$ 151,819,212

Project Timeline

The University Facilities Planning Department prepared the Biomedical Research Project Construction Timeline shown below. As shown, this project will require approximately five years from the date that we advertised for A/E services (August 1, 2001) to the completion of construction in August 2006. Given the nature of this project and the more straightforward design of today's biomedical research facilities, which have significantly fewer specialized research labs and far more generic labs, this schedule could possibly be improved in several areas.

BRT ::: Total Project Timeline

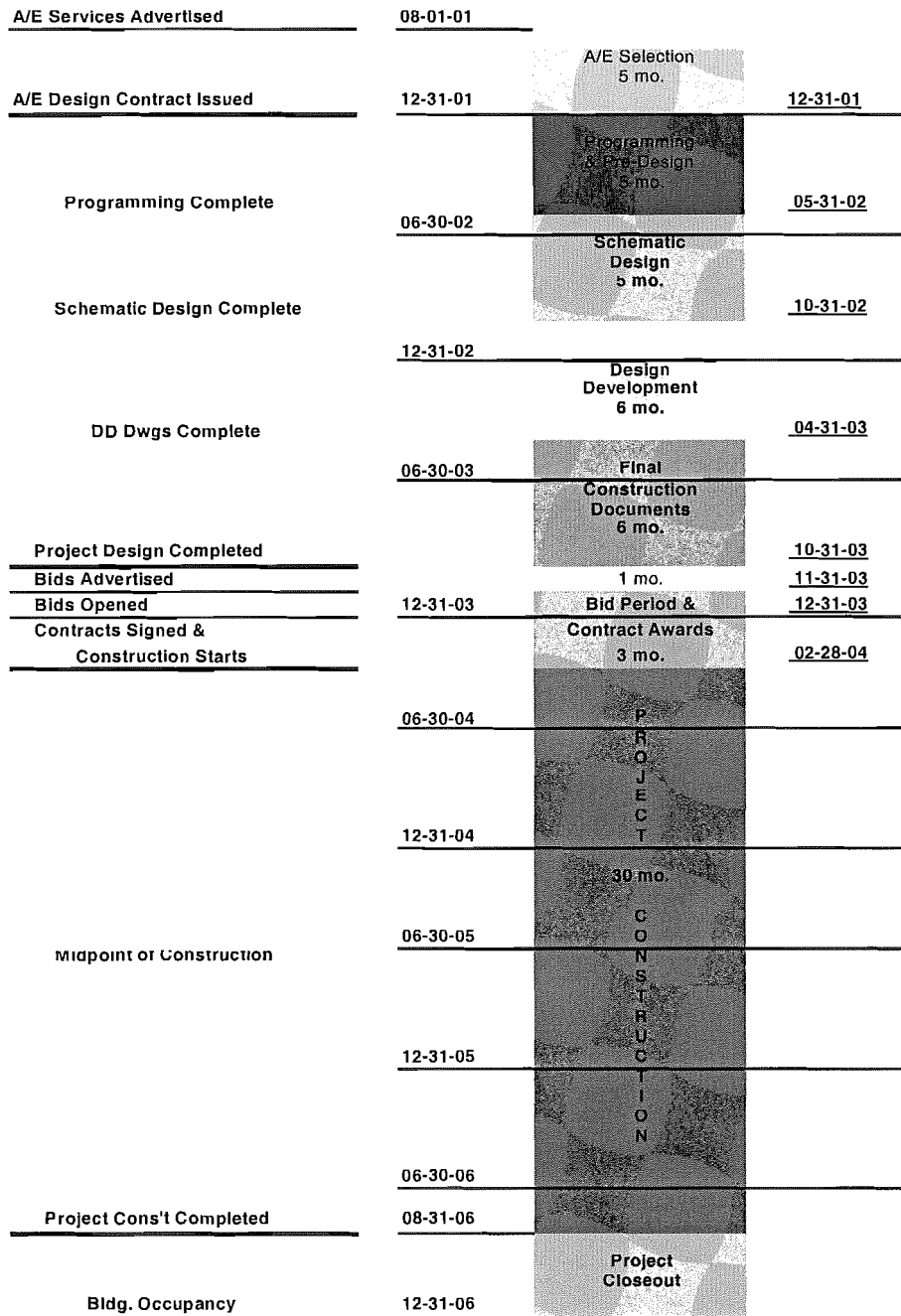

Projected Cash Flow Summary

As noted in the Projected Cash Flow Summary on the following page:

- The Cash Flow Summary shows the Sources and Uses of Funds for the years prior to BRT's completion and for the initial 6 years following BRT's opening. At the end of the 6th fiscal year after completion, the facility would be fully occupied and all start-up costs would have occurred.
- At the end of the fiscal year ending 6-30-06 the medical center's research enterprise will have accumulated net sources of approximately \$24.3M to use for BRT start-up costs.
- In each of the first five fiscal years after opening, BRT's annual use of funds will exceed the annual sources of funds. However, in each year the accumulated net sources carried over from the prior fiscal year is projected to be sufficient to cover the negative annual cash flow.
- For the Fiscal Year ending 6-30-12, and each fiscal year thereafter, the total sources of funds is projected to exceed the total uses of funds and the accumulated net sources continue to grow thereafter.
- When fully occupied at the end of the 5th fiscal year of operation, BRT should accommodate 122 Principal Investigators.
- Scheduled maintenance and renewal is included as a use of funds after the building occupancy in FY 07.

BRT - Projected Cash Flow Summary (FYE 6-30-02 thru FYE 6-30-12)

	FYE 6-30-02	FYE 6-30-03	FYE 6-30-04	FYE 6-30-05	FYE 6-30-06	FYE 6-30-07	FYE 6-30-08	FYE 6-30-09	FYE 6-30-10	FYE 6-30-11	FYE 6-30-12
Sources of Funds											
HRSA Construction Funds		1,000,000									
Office of President Commitment	0	3,000,000	2,400,000	1,800,000	800,000						
Budget Rebasng Phase-In	0	1,000,000	2,000,000	2,400,000	3,000,000	3,000,000	3,000,000	3,000,000	3,000,000	3,000,000	3,000,000
Release Time from BRT Faculty Grants	0	259,386	893,153	1,515,159	1,836,256	3,127,875	4,604,442	5,694,125	6,536,093	7,830,803	8,734,298
Endowed Chairs, Selective Invest, Acad Enrich	121,274	293,499	568,246	916,822	1,183,377	1,527,431	1,739,572	1,796,978	1,856,278	1,917,535	1,980,814
Tobacco Funds	3,000,000	3,099,000	3,201,267	3,306,909	3,416,037	3,528,766	3,645,215				
Additional Release Time from Current Grants	0	666,078	1,332,157	1,998,235	2,664,314	3,224,000	3,330,392	3,440,295	3,553,825	3,671,101	3,792,247
Endowments/Development	300,000	350,000	400,000	450,000	500,000	600,000	619,800	640,253	661,382	683,207	705,753
Add'l ICR for Facilities 18.3% of Directs Costs	136,884	695,714	2,343,096	4,009,474	5,727,426	8,143,357	10,503,679	12,268,911	13,774,285	15,768,207	17,442,639
Add'l ICR for Facilities @ 1.4% of Directs Costs	10,472	53,224	176,254	29,092,829	492,252	668,438	812,200	947,530	1,062,989	1,215,834	1,344,247
Interest - 3.5% On Prior Year's Acc Net Sources	0	0	317,082	358,369	476,054	848,769	641,894	479,596	385,353	309,757	166,432
Total Sources of Funds	3,568,630	10,416,901	13,634,255	17,115,791	20,095,716	24,668,636	28,897,193	28,267,688	30,830,205	34,396,445	37,166,430
Uses of Funds											
Salary & Benefits for BRT Faculty	0	1,133,615	3,691,701	5,829,640	6,134,974	9,079,515	12,519,742	14,700,290	16,750,766	19,248,993	19,884,210
Start-Up Costs for BRT Faculty	0	3,718,800	8,536,712	6,613,818	227,736	9,880,545	11,421,675	5,103,301	4,927,041	6,223,631	0
Annual Interest Costs on Construction Loan	6,450	67,172	226,216	1,309,924	3,083,991	2,174,478					
Annual Debt Service-Constr Bonds (5.5% Rate) (Int'l Proj Cons't Cost+Future Build-out Costs)	0	0	0	0	0	7,944,500	7,944,500	9,032,300	9,032,300	10,197,600	10,197,600
BRT's Annual P.O.M. Costs	0	0	0	0	0	1,321,454	1,365,062	1,733,169	1,790,364	2,254,360	2,328,754
Transfer to BRT's Bldg Sys Ren'l & Replace Fd	0	0	0	0	0	178,864	283,308	391,270	489,619	566,877	680,259
Total Uses of Funds	6,450	4,919,586	12,454,629	13,753,381	9,446,701	30,579,356	33,534,287	30,960,331	32,990,090	38,491,460	33,090,823
Annual Net Sources (Uses)	3,562,180	5,497,315	1,179,626	3,362,410	10,649,014	(5,910,720)	(4,637,093)	(2,692,643)	(2,159,885)	(4,095,016)	4,075,607
Accumulated Net Sources (Uses)		9,059,495	10,239,121	13,601,532	24,250,546	18,339,826	13,702,733	11,010,090	8,850,205	4,755,190	8,830,797
Total Grant Awards for COM&PH	77,350,000	84,447,750	98,010,627	111,401,631	125,207,104	143,714,027	158,815,077	173,030,434	185,158,557	201,213,673	214,702,421
% Increase - Total Grant Awards		9.18%	16.06%	13.66%	12.39%	14.78%	10.51%	8.95%	7.01%	8.67%	6.70%

Project Risk Management Strategies

In order to manage the risks associated with this project, the following strategies will be utilized:

Construction of Shelled Space

As previously noted, we will maintain the initial project cost at \$120.3M by shelling 72,000 asf of the building. This strategy will allow us to better manage the initial project costs, and will also allow us to manage the expenditures for the future build-out costs based on the actual growth in space requirements.

Additional Risk and Commissioning Contingencies

To further protect against project construction cost overruns above the typical 10% construction contingencies, an additional Risk Contingency of 3% and an additional Commissioning Contingency of 1.0% has been included in the project budget.

Management of the Assignment of Space

Several initiatives have been undertaken to insure that indirect cost recoveries are maximized from the assignable square feet available in BRT. First, investigators assigned space in BRT will be at, or progressing to, the benchmark funding level. In addition to reviewing all new requests for space, there will be an annual review of all previously assigned space to insure that current utilization meets this standard. A research space facilities director has been recruited to assist in identifying research space and in developing optimal allocation of research space. This same management strategy is also being applied to existing research facilities to insure maximum utilization.

Management of Indirect Costs Recovery

All facility indirect costs recovery (currently 18.3% for space costs and 1.4% for equipment use and depreciation) that will be generated by the research grants awarded to investigators housed in BRT will be placed into a separate escrow account to be used for all "facility costs" such as bond indebtedness, POM costs, deferred maintenance costs, building and equipment replacement costs, etc. As noted above for the management of space, the management of the indirect costs recovery will be initiated immediately for all research grants, that will be awarded prior to BRT's completion. Strategies such as this will provide sufficient accumulated net sources of funds in reserve that will then be available to offset the annual operating deficit during BRT's first 5 years of operation.

Management of Salary Recovery

A Salary Recovery Policy went into effect in the OSU Medical Center on April 1, 2002. The policy states that when preparing a grant, Principal Investigators should estimate the portion of their time which will be utilized on the project and request that amount of salary support in their budget. The Vice Dean for Research is reviewing grant budgets prior to submission to ensure compliance with this policy. A Faculty Task Force is currently working on the policies and procedures for the administration and management of the salary recovery dollars. The assumptions for the BRT will be incorporated into this document. These policies and procedures will also include specifics on faculty incentives. In addition, letters of offer to new faculty include grant and salary recovery expectations, which are consistent with the BRT assumptions.

(APPENDIX IX)

**FIRST AMENDMENT
TO
THE OHIO STATE UNIVERSITY
SUPPLEMENTAL QUALIFIED RETIREMENT PLAN**

WHEREAS The Ohio State University (the "University") sponsors The Ohio State University Supplemental Qualified Retirement Plan, as effective on July 1, 2001, (the "Plan") to provide retirement benefits to certain eligible employees; and

WHEREAS pursuant to Section 10.01 of the Plan, the University is authorized to amend the Plan; and

WHEREAS the University now desires to amend the Plan to conform the Plan to recent pension law changes;

NOW THEREFORE, the Plan is amended, effective as indicated herein, in the following respects:

1. The name of the Plan shall be The Ohio State University Retirement Continuation Plan.
2. Section 2.01, Eligibility for Pick-Up Contributions, is amended by adding the following sentences to the end thereof:

"The Plan Administrator may, at its discretion, add employees to, or delete employees from, Appendix A. Eligibility for Pick-Up Contributions shall begin after all of the mandatory employee contributions to ARP, PERS, or STRS are made each year."

3. Section 2.02, Eligibility for Employer Contributions, is replaced in its entirety, as follows:

"Eligibility for an allocation of the Employer Contribution, if any, is limited to those Employees selected by the Plan Administrator and listed in Appendix A. The Plan Administrator may, at its discretion, add employees to, or delete employees from, Appendix A. Eligibility for an Employer Contribution and the amount of the Employer Contribution may vary from year to year and the fact that an Employee receives such contribution one year does not mean that he is entitled to such contribution in any future year."

4. Section 3.03, Employer Contributions, is amended by adding the following sentence to the end of the first paragraph, as follows:

"The Employer Contribution shall be made on the last day of each Plan Year for any Participant who is participating in the Plan on the last day of the Plan Year."

5. Section 7.04(b)(2), Eligible Retirement Plan, is replaced with the following language:

"(2) Eligible Retirement Plan – An Eligible Retirement Plan is an individual retirement account described in Section 408(a) of the Code, an individual retirement annuity described in Section 408(b) of the Code, an annuity plan described in Section 403(a) of the Code, a qualified trust described in Section 401(a) of the Code, an annuity contract described in Section 403(b) of the Code, and an eligible plan under Section 457(b) of the Code which is maintained by a state, political subdivision of a state or any agency or instrumentality of a state or political subdivision of a state and which agrees to separately account for amounts transferred into such plan from this Plan, that accepts the Distributee's Eligible Rollover Distribution. An Eligible Retirement Plan shall also apply in the case of a distribution to a surviving spouse, or to a spouse or former spouse who is an alternate payee under a qualified domestic relations order, as defined in Section 414(p) of the Code."

6. Section 7.07, Acceptance of Transfers or Rollovers, is added:

“No transfers or rollovers (direct or otherwise) shall be permitted to this Plan from another plan or annuity.”

Beginning January 1, 2003, Section 7.07, Acceptance of Transfers or Rollovers will be renumbered as Section 7.05, Acceptance of Transfers or Rollovers.

7. Beginning January 1, 2003, Section 7.05, Required Commencement of Benefits, is renumbered as Article VIII, Minimum Distribution Requirements, and is replaced in its entirety, as follows:

Article VIII – MINIMUM DISTRIBUTION REQUIREMENTS

Section 8.01 - General Rules

- (a) **Effective Date.** The provisions of this Article will apply for purposes of determining required minimum distributions for calendar years beginning with the 2003 calendar year.
- (b) **Precedence.** The requirement of this Article will take precedence over any inconsistent provisions of the Plan.
- (c) **Requirements of Treasury Regulations Incorporated.** All distributions required under this Article will be determined and made in accordance with the Treasury regulations under section 401(a)(9) of the Internal Revenue Code.

Section 8.02 - Time and Manner of Distribution

- (a) **Required Beginning Date.** The Participant's entire interest will be distributed, or begin to be distributed, to the Participant no later than the Participant's required beginning date.
- (b) **Death of Participant Before Distributions Begin.** If the Participant dies before distributions begin, the Participant's entire interest will be distributed, or begin to be distributed, no later than as follows:
 - (1) If the Participant's surviving spouse is the Participant's sole Designated Beneficiary, then, distributions to the surviving spouse will begin by December 31 of the calendar year immediately following the calendar year in which the Participant died, or by December 31 of the calendar year in which the Participant would have attained age 70½, if later.
 - (2) If the Participant's surviving spouse is not the Participant's sole Designated Beneficiary, then distribution to the Designated Beneficiary will begin by December 31 of the calendar year immediately following the calendar year in which the Participant died.
 - (3) If there is no Designated Beneficiary as of September 30 of the year following the year of the Participant's death, the Participant's entire interest will be distributed by December 31 of the calendar year containing the fifth anniversary of the Participant's death.
 - (4) If the Participant's surviving spouse is the Participant's sole Designated Beneficiary and the surviving spouse dies after the Participant but before distributions to the surviving spouse begin, this section 8.02(b), other than section 8.02(b)(1), will apply as if the surviving spouse were the Participant.

For purposes of this section 8.02(b) and section 8.04, unless section 8.02(b)(4) applies, distributions are considered to begin on the Participant's required beginning date. If section 8.02(b)(4) applies, distributions are considered to begin on the date distributions are required to begin to the surviving spouse under section 8.02(b)(1). If distributions under an annuity purchased from an insurance company irrevocably commence to the Participant before the Participant's required beginning date (or to the Participant's surviving spouse before the date distributions are required to begin to the surviving spouse under section 8.02(b)(1)), the date distributions are considered to begin is the date distributions actually commence.

- (c) **Forms of Distribution.** Unless the Participant's interest is distributed in the form of an annuity purchased from an insurance company or in a single sum on or before the required beginning date, as of the first distribution calendar year distributions will be made in accordance with sections 8.03 and 8.04 of this Article. If the Participant's interest is distributed in the form of an annuity purchased from an insurance company, distributions thereunder will be made in accordance with the requirements of section 401(a)(9) of the Code and the Treasury regulations.

Section 8.03 – Required Minimum Distributions During Participant's Lifetime

- (a) **Amount of Required Minimum Distribution For Each Distribution Calendar Year.** During the Participant's lifetime, the minimum amount that will be distributed for each distribution calendar year is the lesser of:
 - (1) The quotient obtained by dividing the Participant's Account Balance by the distribution period in the Uniform Lifetime Table set forth in section 1.401(a)(9)-9 of the Treasury regulations, using the Participant's age as of the Participant's birthday in the distribution calendar year; or
 - (2) If the Participant's sole Designated Beneficiary for the distribution calendar year is the Participant's spouse, the quotient obtained by dividing the Participant's Account Balance by the number in the Joint and Last Survivor Table set forth in section 1.401(a)(9)-9 of the Treasury regulations, using the Participant's and spouse's attained ages as of the Participant's and spouse's birthdays in the distribution calendar year.
- (b) **Lifetime Required Minimum Distributions Continue Through Year of Participant's Death.** Required minimum distributions will be determined under this section 8.03 beginning with the first distribution calendar year and up to and including the distribution calendar year that includes the Participant's date of death.

Section 8.04 – Required Minimum Distributions After Participant's Death

- (a) **Death On or After Date Distributions Begin.**
 - (1) **Participant Survived by Designated Beneficiary.** If the Participant dies on or after the date distributions begin and there is a Designated Beneficiary, the minimum amount that will be distributed for each distribution calendar year after the year of the Participant's death is the quotient obtained by dividing the Participant's Account Balance by the longer of the remaining life expectancy of the Participant or the remaining life expectancy of the Participant's Designated Beneficiary, determined as follows:
 - (i) The Participant's remaining life expectancy is calculated using the age of the Participant in the year of death, reduced by one for each subsequent year.

- (ii) If the Participant's surviving spouse is the Participant's sole Designated Beneficiary, the remaining life expectancy of the surviving spouse is calculated for each distribution calendar year after the year of the Participant's death using the surviving spouse's age as of the spouse's birthday in that year. For distribution calendar years after the year of the surviving spouse's death, the remaining life expectancy of the surviving spouse is calculated using the age of the surviving spouse as of the spouse's birthday in the calendar year of the spouse's death, reduced by one for each subsequent calendar year.
 - (iii) If the Participant's surviving spouse is not the Participant's sole Designated Beneficiary, the Designated Beneficiary's remaining life expectancy is calculated using the age of the Beneficiary in the year following the year of the Participant's death, reduced by one for each subsequent year.
 - (2) No Designated Beneficiary. If the Participant dies on or after the date distributions begin and there is no designated Beneficiary as of September 30 of the year after the year of the Participant's death, the minimum amount that will be distributed for each distribution calendar year after the year of the Participant's death is the quotient obtained by dividing the Participant's Account Balance by the Participant's remaining life expectancy calculated using the age of the Participant in the year of death, reduced by one for each subsequent year.
- (b) Death Before Date Distributions Begin.
- (1) Participant Survived by Designated Beneficiary. If the Participant dies before the date distributions begin and there is a Designated Beneficiary, the minimum amount that will be distributed for each distribution calendar year after the year of the Participant's death is the quotient obtained by dividing the Participant's Account Balance by the remaining life expectancy of the Participant's Designated Beneficiary, determined as provided in section 8.04(a).
 - (2) No Designated Beneficiary. If the Participant dies before the date distributions begin and there is no Designated Beneficiary as of September 30 of the year following the year of the Participant's death, distribution of the Participant's entire interest will be completed by December 31 of the calendar year containing the fifth anniversary of the Participant's death.
 - (3) Death of Surviving Spouse Before Distributions to Surviving Spouse Are Required to Begin. If the Participant dies before the date distributions begin, the Participant's surviving spouse is the Participant's sole Designated Beneficiary, and the surviving spouse dies before distributions are required to begin to the surviving spouse under section 8.02(b)(1), this section 8.04(b) will apply as if the surviving spouse were the Participant.

Section 8.05 – Definitions

- (a) Designated Beneficiary. The individual who is designated as the Beneficiary under section 1.04 of the Plan and is the Designated Beneficiary under section 401(a)(9) of the Internal Revenue Code and section 1.401(a)(9)-1, Q&A-4, of the Treasury regulations.
- (b) Distribution calendar year. A calendar year for which a minimum distribution is required. For distributions beginning before the Participant's death, the first distribution calendar year is the calendar year immediately preceding the calendar year which contains the participant's required beginning date. For distributions

beginning after the Participant's death, the first distribution calendar year is the calendar year in which distributions are required to begin under section 8.02(b). The required minimum distribution for the Participant's first distribution calendar year will be made on or before the Participant's required beginning date. The required minimum distribution for other distribution calendar years, including the required minimum distribution for the distribution calendar year in which the Participant's required beginning date occurs, will be made on or before December 31 of that distribution calendar year.

- (c) Life expectancy. Life expectancy as computed by use of the Single Life Table in section 1.401(a)(9)-9 of the Treasury regulations
- (d) Participant's Account Balance. The Account Balance as of the last valuation date in the calendar year immediately preceding the distribution calendar year (valuation calendar year) increased by the amount of any contributions made and allocated or forfeitures allocated to the Account Balance as of dates in the valuation calendar year after the valuation date and decreased by distributions made in the valuation calendar year after the valuation date. The Account Balance for the valuation calendar year includes any amounts rolled over or transferred to the plan either in the valuation calendar year or in the distribution calendar year if distributed or transferred in the valuation calendar year.
- (e) Required beginning date. The required beginning date is April 1 of the calendar year following the calendar year in which the Participant attains age 70½ or retires, whichever is later.

- 8. Beginning January 1, 2003, all remaining Articles and applicable sections shall be consecutively renumbered to follow Article VIII above.

IN WITNESS WHEREOF, the University hereby adopts this First Amendment to The Ohio State University Supplemental Qualified Retirement Plan, effective as of January 1, 2002, except as otherwise noted herein, this 12th day of July 2002.

BOARD OF TRUSTEES RESOLUTIONS

FY 2002-2003 TUITION INCREASE

March 1, 2002

Synopsis: Instructional and General fees for undergraduate students enrolled at the Columbus Campus for fiscal year 2002-2003 are proposed.

WHEREAS the Board of Trustees of The Ohio State University supports the tuition strategy and recommendations presented at their February 1, 2002, meeting as critical to providing the resources necessary for the University to implement the Academic Plan and meet the needs of Ohio State University students; and

WHEREAS in recognition of the concerns raised about the economic difficulty many Ohio families now face, the Board supports modification of those recommendations to phase in the additional fees for new entering students at the Columbus Campus over the next two or three years; and

WHEREAS the Board anticipates it will be necessary to charge new entering students additional fees beyond those charged for continuing students for each of the next two or three years until the tuition plan is fully implemented; and

WHEREAS the tuition rates to be adopted are specifically based on the current level of State support and could be modified if State support for higher education is either increased or decreased; and

WHEREAS consultations continue to take place with regard to professional college, regional campus and nonresident fees and those fees will be determined as a part of the regular 2002-03 budget process:

NOW THEREFORE

BE IT RESOLVED, That Instructional and General Fees for all undergraduates enrolled at the Columbus Campus be increased by 9.0% (\$143 per quarter) for Fiscal Year 2002-03, beginning Summer Quarter 2002; and

BE IT FURTHER RESOLVED, That Instructional and General Fees for all new undergraduates enrolled at the Columbus Campus be increased by an additional \$158 per quarter for fiscal year 2002-03, beginning Summer Quarter 2002.

2002-2003 TUITION INCREASES ATI, REGIONAL CAMPUSES, AND NON-RESIDENT SURCHARGE

April 5, 2002

Synopsis: Instructional and General fees for undergraduate students enrolled at ATI and the Regional Campuses and the Non-resident Surcharges for undergraduate students enrolled at all campuses for Fiscal Year 2002-2003 are proposed effective Summer Quarter 2002.

WHEREAS the Board of Trustees of The Ohio State University, at their March 1, 2002 meeting, approved Instructional and General fees for undergraduate students enrolled at the Columbus Campus for the Fiscal Year 2002-2003 effective Summer Quarter 2002; and

WHEREAS the State has provided Access Challenge funding to the Agricultural Technical Institute (ATI) and the Regional Campuses, and the Regional Campuses wish to allocate a greater portion of those funds to lower-division students than in the past in accordance with the purpose of those funds; and

WHEREAS ATI and the Regional Campuses wish to keep the average increase in all of their undergraduate Instructional and General fees net of Access Challenge for Fiscal Year 2002-2003 at under 10% and also wish to implement these increases effective Summer Quarter 2002; and

WHEREAS the Board of Trustees supports the tuition strategy and recommendations made by the Executive Dean of the College of Food, Agricultural, and Environmental Sciences for ATI and jointly by the Boards of Trustees of the Regional Campuses; and

WHEREAS it is necessary now to set the Undergraduate Non-resident surcharges, which are the same at all campuses, for Fiscal Year 2002-2003 in order to be effective for Summer Quarter 2002; and

WHEREAS the tuition rates to be adopted are specifically based on the current level of State support and could be modified if State support for higher education is either increased or decreased; and

WHEREAS consultations continue to take place with regard to professional college fees and those fees will be determined as part of the regular 2002-2003 budget process and will be effective Autumn Quarter 2002:

NOW THEREFORE

BE IT RESOLVED, That effective Summer Quarter 2002, Fiscal Year 2002-03 Instructional and General Fees for undergraduate students enrolled at ATI, net of Access Challenge credits, be increased by 9.9% (\$119 per quarter for a full-time student; and

BE IT FURTHER RESOLVED, That effective Summer Quarter 2002, the Fiscal Year 2002-2003 Instructional and General Fees for undergraduate students enrolled at the Regional Campuses be increased by 8.0% (\$112 per quarter for a full-time student) and that these fees be reduced by Access Challenge credits for lower-division students by \$200 per quarter for full-time students for a net increase of 8.9% (\$107 per quarter), and for upper-division students by \$54 per quarter for full-time students for a net increase of 12.8% (\$165 per quarter), with the average for all students at just under 10%; and

BE IT FURTHER RESOLVED, That effective Summer Quarter 2002, the Fiscal Year 2002-2003 Non-resident surcharge for undergraduate students enrolled at all campuses be increased by 7.5% (\$219 per quarter for a full-time student).

FY 2002-2003 COMPENSATION BUDGET

MAY 3, 2002

Synopsis: Approval of the FY 2002-2003 Compensation Budget, is proposed.

WHEREAS the current budget expires on June 30, 2002; and

WHEREAS faculty and staff salaries are significantly behind those of the University's benchmarks and other appropriate comparison groups; and

WHEREAS financial support for graduate associates is significantly behind the University's benchmarks, and we are currently in the second year of a three-year plan to contribute more financial support in the form of benefits subsidy for graduate associates; and

WHEREAS the University aspires to achieve market competitive salaries by providing salary budgets of up to 1% above comparable institutions each year for the next several years; and

WHEREAS budgeted amounts for faculty and staff salary increases at comparable institutions are projected to average 3.5% over the next 12 months:

NOW THEREFORE

BE IT RESOLVED, That the Board of Trustees approves budgeted increases to the salary pool in the range of 4.5% for faculty, staff and graduate associates to take effect at the beginning of fiscal year 2003.

2002-03 GRADUATE AND PROFESSIONAL STUDENT TUITION AND LEARNING TECHNOLOGY FEE INCREASES

June 7, 2002

Synopsis: Instructional, General and Nonresident fees for Graduate and Professional students and the Learning Technology fees for fiscal year 2002-03 are proposed.

WHEREAS the Board of Trustees of The Ohio State University approved the Columbus Campus Undergraduate Instructional and General fees to be effective Summer Quarter at their April meeting; and

WHEREAS the Board of Trustees approved the Agricultural Technical Institute and Regional Campus undergraduate instructional and general fees net of Access Challenge credits as well as the undergraduate nonresident surcharges at all campuses effective Summer Quarter at their May meeting; and

WHEREAS the professional colleges have now completed consultations with their students in regards to the level of their instructional fees above a 5% base to be used by those colleges to improve services to their students; and

WHEREAS the Learning Technology fees for specific colleges need to be approved for FY 2002-03.

NOW THEREFORE

BE IT RESOLVED, That the Graduate Instructional fees for all campuses be increased 5.0% (\$102 per quarter for a full-time student), effective Autumn Quarter 2002; and

BE IT FURTHER RESOLVED, That the General Fees for all graduate and professional students at the Columbus Campus will be the same as for undergraduates (\$120 per quarter and \$180 per semester for a full-time student), effective Autumn Quarter 2002; and

BE IT FURTHER RESOLVED, That the Nonresident Surcharges for all graduate and professional students at the Columbus Campus will increase 5.0% in accordance with the attached budget materials, effective Autumn Quarter 2002; and

BE IT FURTHER RESOLVED, That Differential (Instructional) Fees for the Professional Colleges and specific graduate programs at the Columbus Campus be increased in accordance with the attached budget materials, effective Autumn Quarter 2002, including three new graduate differential fees in the College of Medicine and Public Health for Health Administration, Public Health MPH and Public Health PEP; and

BE IT FURTHER RESOLVED, That the Learning Technology fees in place for specific colleges and programs at the Columbus Campus will not increase for FY 2003 and that no new Learning Technology fees will be introduced in FY 2003 in accordance with the attached budget materials.

APPROVAL OF FISCAL YEAR 2003 CURRENT FUNDS BUDGET

July 12, 2002

Synopsis: Approval of the budget for fiscal year 2002-03 is proposed.

WHEREAS the State has passed its budget for Fiscal Years 2002 and 2003, which includes funding levels for State institutions of higher education; and

WHEREAS fee increases for the Columbus and Regional Campuses and compensation levels were approved at previous meetings of the Board of Trustees; and

WHEREAS other levels of resources and expenditures have been identified for the 2002-03 fiscal year; and

WHEREAS fees other than tuition also need to be approved; and

WHEREAS appropriate planning and consultation within the University has been accomplished, and the Interim President now recommends approval of the Fiscal Year 2003 budget:

NOW THEREFORE

BE IT RESOLVED, That the University's Current Funds Budget for Fiscal Year 2002-03, as described in the accompanying text and tables, be approved, with authorization for the University to make expenditures within the projected income levels; and

BE IT FURTHER RESOLVED, That fees other than tuition be approved as specified in the accompanying text and tables as well as other fees submitted to and approved by the Office of Business and Finance in the course of the budget process including changes to the late registration and late payment of fees for all students retroactive for FY 2002 as specified in the accompanying tables.

I. BUDGET PLANNING SUMMARY

Academic Plan

A great university is measured by the quality of the research, scholarship, and graduates it produces along with their collective impact on the larger society. To be a great university, the prevailing culture must demand excellence in all endeavors. That excellence can only be achieved when all parts of the university are committed to the highest standards of performance. Ohio State is committed to such an environment of academic excellence.

In 1992, Ohio State formulated the University's original mission and vision statement focusing on the quality of our academic programs; the quality of the learning experience we offer our students; creating an environment that truly values and is enriched by diversity; and expanding the land-grant mission to address our society's most compelling needs.

In 2000, the University began a review of the 1992 mission and vision statement. A group of Ohio State deans, faculty and administrators developed the Academic Plan. The draft Academic Plan was reviewed

and refined by faculty, staff and students as well as representatives from the extended Ohio State community.

The six strategies identified in the Academic Plan reflect the values and aspirations of a broad cross section of the University community.

Strategies:

- **Build a World-Class Faculty.**
- **Develop Academic Programs that Define Ohio State as the Nation's Leading Public Land-Grant University.**
- **Enhance the Quality of the Teaching and Learning Environment.**
- **Enhance and Better Serve the Student Body.**
- **Create a Diverse University Community.**
- **Help Build Ohio's Future.**

These strategies and their related initiatives serve as a roadmap for the University. However, the pace at which the University is able to implement the Plan depends

upon a number of circumstances, including the availability of financial resources.

Progress on the Plan was hampered in late Spring 2001 when the Governor of Ohio announced the need to reduce the FY 2001 operating appropriations for higher education by 1%. The total cut to OSU was \$4.5 million.

In FY 2002, continued state budget woes led to the smallest increase in the University's state support in nine years. Progress on the Academic Plan was further constrained by a 32% increase in the University share of employee health benefit costs and the largest increase in energy costs in two decades.

The limited growth in University resources was targeted to four areas determined to be most critical to the Academic Plan:

- Competitive faculty and staff compensation;
- A series of enhancements to our undergraduate program;
- A major biomedical research initiative, drawing in part upon the Tobacco Settlement funds; and
- Creation of the William E. Kirwan Institute for the Study of Race and Ethnicity in the Americas, using funds earmarked in a prior year.

The limited ability of the University in FY 2002 to invest in employee compensation clearly put Ohio State further

behind a number of its aspirational peers' compensation levels.

The President, in October 2001, reaffirmed competitive salaries as the University's number one priority and established the compensation goal of bringing OSU salary levels up to the median salary levels of our benchmarks within the next three or four years. To meet that goal, it was estimated the University would have to provide compensation increases that, on average, were 1% above the market.

Also in the Fall 2001, the state announced the second reduction in state support this calendar year. The FY 2002 cut of 6% reduced OSU funding by about \$28 million; \$20 million was cut from the Columbus campus state share of instruction, and over \$8 million was cut from specific line-item appropriations and the regional campuses. This reduced our state share of instruction to 1999 levels.

To address the additional cuts and meet its competitive compensation goal, the University began planning in the fall for FY 2003 budget reallocations. Plan guidelines called for academic units to assume reallocations of up to 5% and for academic support units to assume reallocations of up to 7%. In addition, a committee was established to recommend reductions in central university commitments of up to \$4 million.

BUDGET CONTEXT

At the beginning of the FY 2003 budget planning process, the University presented a financial benchmark report to its Board of Trustees. The report compares OSU's financial trends with nine benchmark institutions in a number of key areas.

The nine benchmark institutions include, in order of their relative rank: Michigan, UCLA, Wisconsin-Madison, Washington, Illinois-Urbana/Champaign, Minnesota-Twin Cities, Texas-Austin, Penn State, and Arizona.

These institutions represent public higher-education institutions of the highest quality that most closely resemble Ohio State in organization and missions. The institutions represent Ohio State's peers and aspirational peers. Using the most-recent audited financial data available, FY 2000, the financial comparisons follow:

- Current Funds Revenues per FTE student at Ohio State are significantly (18%) below the average of our benchmark institutions. However, this represents a 5-percentage point improvement over FY 1996.
- State support per student FTE at Ohio State (\$9,203) in FY 2000 is also less (6.3%) than benchmark institutions. State appropriations are the slowest

growing revenue source: the average annual growth rate from 1992 to 2000 is .8% in real terms (2000 constant dollars).

- While instructional expenditures per student FTE at Ohio State are 7% higher than the benchmark average, expenditures on academic support outside the classroom are 40% below the benchmark average.

The comparison of fees and tuition based on FY 2002 data shows:

- Resident undergraduate tuition and fees at Ohio State are 3.2% below the benchmark average in FY 2002.
- Ohio State is ranked higher than any other Ohio public university in academic reputation. Yet, Ohio State's resident undergraduate tuition and fees are 4.4% below the state average. This makes Ohio State an excellent value for students and taxpayers, and it also means Ohio State does not have the resources to match our competition in key academic and support areas.

The University will continue to develop benchmarking of key academic, demographic and administrative issues to inform decisions on budget prioritization.

II. ACADEMIC BUDGET PRIORITIES

Strategies and Initiatives

The FY 2003 budget process continues to be guided by the Academic Plan and the primary focus remains:

- Competitive faculty and staff compensation;
- A series of enhancements to our undergraduate programs;
- A major biomedical research initiative, drawing in part upon the Tobacco Settlement funds; and
- Creation of the William E. Kirwan Institute for the Study of Race and Ethnicity in the Americas, using funds earmarked in a prior year.

Two key elements relating to resources necessary to achieve the strategic goals set forth in the Academic Plan were an increase in state share of instruction and an increase in undergraduate tuition.

Unfortunately, the combination of a slowing state economy and the court order to address inadequacies in the state support of primary and secondary education continues to constrain state support. In FY 2002, the

budgeted increase in state support of .8% was the lowest increase in nine years. In FY 2003, following a 6% cut in the already low level of state support, the state is providing no increase in state support.

However, with the support of state officials, an innovative plan was approved to phase-in an increase in Ohio State's tuition to reach a level commensurate with the University's mission and its role as the state's flagship university. This would provide the University with the resources necessary to achieve the goals of the Academic Plan while keeping Ohio State's commitment to hold continuing students' tuition to a growth rate of about 9% per year. A two-tier tuition plan was developed, effective Summer Quarter 2002, to increase undergraduate tuition by 9% for continuing students and by the same 9% plus an additional \$158 per quarter for new students. Of this increase, 30% of the additional student tuition dollars are earmarked for student financial aid to assure continued access for the students in most need.

Revenue generated from the tuition increase and increased enrollments, combined with \$20 million in University budget cuts and \$8 million in reallocations, will allow the University to keep its commitment to fund:

- Average pay increases for faculty and staff in the range of 4.5% (roughly equal to 1% above the market)
- Contractual pay increases for bargaining unit staff
- Estimated 12% average increase in the University share of employee benefits costs.

Other FY 2003 funding priorities include continued commitments to improve the undergraduate experience, including access to high demand courses and improved counseling; strategic investments; increased support for research, revenue enhancement programs, and student recruitment. In addition, the FY 2003 budget continues to support initiatives designed to diversify revenue sources through increased private fund raising and sponsored research.

Thus, although the University will make progress on its strategic goals, during the coming year, implementation of the Academic Plan will be accomplished at a much slower pace than originally anticipated.

Budget Restructuring

The University is moving away from a budget structure that is heavily driven by past history to one that more directly aligns financial incentives for the colleges with the academic goals of the University.

Over the last six years, the University has been preparing for budget restructuring. This preparation includes development of an academic plan, reconciliation of college base budgets with academic goals and a set of allocation principles for moving forward.

Beginning in FY 2003, annual increases in revenues and expenditures are shared with the colleges based on the following principles of the new budget system:

- The allocation of resources should be mission driven.
- In a large, complex organization, decentralized decision-making works best.
- Any budget system, but particularly one that is decentralized, depends on the creation and maintenance of a timely and user-friendly information system.
- A significant portion of revenues should be explicitly linked to the generating units, specifically the colleges.
- A portion of all revenues should be dedicated to the support of university-wide goals.

**SUMMARY OF ANNUAL GENERAL FUNDS BUDGET CHANGES
COLUMBUS CAMPUS BY COLLEGE
FY 2002 TO FY 2003 (IN THOUSANDS)**

- Costs should also be explicitly linked to the generating college or vice presidential area.
- Although the system should be mission driven, predictability and stability are also important characteristics.
- Appropriate oversight and accountability should be provided by the University's governance and administrative structure.
- A carefully thought out transition is essential to the ultimate success of any changes in the budget system.
- While budget restructuring is not a panacea for the University's low level of financial support, it will provide greater incentives for units to generate resources consistent with the goals of the Academic Plan.

The tables on the right and on the following page are summaries of the net increases in General Fund resources for all colleges and academic support areas in FY 2003.

College	FY02 PBA (3/31/02)	FY03 Annual Budget Change (1)	FY03 Transfers (2)	FY03 Projected PBA After Budget Process and Transfers	Pct. Increase
Arts	\$ 19,609	\$ 552	\$ 2	\$ 20,163	2.8%
Biological Sci.	\$ 17,144	\$ 616	\$ 526	\$ 18,286	6.7%
Humanities	\$ 39,728	\$ 2,452	\$ 799	\$ 42,978	8.2%
Math & Phy Sci	\$ 48,620	\$ 1,501	\$ 995	\$ 51,115	5.1%
Soc & Behav Sci	\$ 36,964	\$ 2,238	\$ 887	\$ 40,089	8.5%
Business	\$ 23,424	\$ 2,426	\$ 202	\$ 26,052	11.2%
FAES	\$ 15,389	\$ 180	\$ 97	\$ 15,666	1.8%
Education	\$ 21,330	\$ 604	\$ 346	\$ 22,280	4.5%
Engineering	\$ 47,354	\$ 1,042	\$ 1,393	\$ 49,789	5.1%
Human Ecology	\$ 5,373	\$ 349	\$ 160	\$ 5,882	9.5%
Nursing	\$ 5,067	\$ 22	\$ 15	\$ 5,105	0.7%
Pharmacy	\$ 7,282	\$ 244	\$ 552	\$ 8,077	10.9%
Social Work	\$ 3,572	\$ 43	\$ 119	\$ 3,734	4.5%
Dentistry (3)	\$ 16,060	\$ 345	\$ (55)	\$ 16,350	1.8%
Law (4)	\$ 12,080	\$ 309	\$ 140	\$ 12,530	3.7%
Med & Pblc Hlth (3) (5)	\$ 36,122	\$ 1,525	\$ 4,806	\$ 42,453	17.5%
Optometry	\$ 3,098	\$ 280	\$ 246	\$ 3,624	17.0%
Veterinary Med	\$ 16,595	\$ 227	\$ 428	\$ 17,250	3.9%
Total	\$ 374,810	\$ 14,956	\$ 11,658	\$ 401,425	7.1%

(1) Includes the total marginal resources allocation minus marginal assessments for space, research administration, student services and the central tax. Figures also include the 2.5% PBA budget cut, Faculty Promotions and Differential Fees. Does not include budget reallocations produced by job abolishments and expenses shifted to non-general fund revenue sources in FY03 to partially fund pay increases.

(2) Column includes the sum of CDRS/DDRS decentralization; estimated share of additional FY02 indirect cost recovery distribution; rebasing commitments; revenue enhancement subsidy cash conversion to annual rate; selective investment; promotion increases and closed-course program close out.

(3) Excluding Hospital Transfer

(4) Includes Law Library

(5) Rebasing resources equal \$1M in continuing funds and \$3M in one-time funds. A total of \$4.7M in continuing rebasing funds to be transferred through FY 2007. The total amount is subject to further refinement due to space cost issues.

**SUMMARY OF ANNUAL GENERAL FUNDS BUDGET CHANGES
COLUMBUS CAMPUS BY ACADEMIC SUPPORT AREAS**

FY 2002 TO FY 2003 (IN THOUSANDS)

College	FY02 PBA (3/31/02)	FY03 Annual Budget Change (1)	FY03 Transfers (2)	FY03 Projected PBA After Budget Process and Transfers	Pct. Increase
Ag. Admin (Cont. Ed.)	\$ 1,014	\$ (15)	\$ 0	\$ 999	-1.4%
Ag Admin.	\$ 393	\$ 9	\$ 52	\$ 454	15.7%
College of Law Library (3)	\$ -	\$ -	\$ -	\$ -	
Graduate School (4)	\$ 6,534	\$ 111	\$ 5	\$ 6,649	1.8%
University Libraries (5)	\$ 23,366	\$ (382)	\$ 104	\$ 23,087	-1.2%
University Relations	\$ 4,135	\$ 18	\$ 74	\$ 4,228	2.2%
Board of Trustees	\$ 688	\$ (8)	\$ -	\$ 680	-1.1%
Office of the President	\$ 2,464	\$ (32)	\$ -	\$ 2,432	-1.3%
Legal Affairs	\$ 1,274	\$ 2	\$ 15	\$ 1,291	1.3%
Office of Research (6)	\$ 6,990	\$ (243)	\$ 1,388	\$ 8,136	16.4%
OAA	\$ 38,388	\$ 122	\$ 15	\$ 38,526	0.4%
Undergraduate Studies	\$ 27,947	\$ (351)	\$ 400	\$ 27,997	0.2%
Office of Student Affrs	\$ 15,003	\$ (179)	\$ 78	\$ 14,902	-0.7%
Health Sciences (7)	\$ 6,075	\$ (53)	\$ 1,238	\$ 7,260	19.5%
Business and Finance	\$ 64,061	\$ (21)	\$ 177	\$ 64,218	0.2%
Sub-Total	\$198,333	\$ (1,021)	\$ 3,547	\$ 200,858	1.3%
OSURF (8)	\$ 6,494	\$ 370	\$ 1,000	\$ 7,864	21.1%
Total	\$204,827	\$ (651)	\$ 4,547	\$ 208,722	1.9%

Notes:

(1) Includes the net marginal resources allocation minus the 3.5% budget cut. Does not include budget reallocations produced by job abolishments in FY 2003 to partially fund pay increases. Does not include budgets for central initiatives and student financial aid.

(2) Column includes the sum of CDRS/DDRS decentralization; estimated share of additional FY2002 indirect cost recovery distribution; central transfers to fund FY 2003 mandates and recruitment enhancement.

(3) Law Library included in College of Law's budget, although the library's marginal budgetary growth is funded by the central tax.

(4) Fellowship Stipend budget includes 4.5% stipend increase.

(5) Additional IDC Allocation includes a portion of the Library's 2.38% of Marginal IDC's from FY02 (56% of \$140,575) and FY 2003 (56% of \$44,000). The acquisitions budgets of all libraries were excluded from the 2.5% budget reallocation used to partially fund compensation increases.

(6) Figures include additional FY 2002 IDC Recoveries including \$700,000 for ULAR and \$500,000 for Research Risks Protection.

(7) Additional IDC Allocation includes a portion of the Library's 2.38% of Marginal IDC's from FY02 (38% of \$140,575) and FY03 (38% of \$44,000).

(8) Office of Research will absorb the 3.5% cut for OSURF. Annual budget change for OSURF includes 4.5% salary increase with benefits, (with a 2.5% reallocation), and \$200,000 for systems upgrades. OSURF excluded from sub-total because it is separately budgeted.

III. FY 2003 REVENUE SUMMARY

Overview

Total University's current funds revenues including General Funds, Earnings and Restricted revenue are projected to increase by 12.3% from \$2.27 billion to \$2.55 billion between FY 2002 and FY 2003.

General Fund revenues for the Columbus Campus consist primarily of State Support (the state share of instruction, challenge funding and state line-item appropriations), student tuition and fees. General Fund revenues are projected to increase by \$47.8 million or 6% in FY 2003. With the implementation of Budget Restructuring, \$39.4 million, or over 82% of the increase in General Fund revenue will be directly allocated to the college budgets or invested selectively in strategic initiatives identified in the Academic Plan; and \$8.3 million, or 16.3%, will be allocated to the academic support unit budgets.

In the FY 2002 Current Funds Budget, revenue from student tuition was projected to exceed state instructional

support at the Columbus Campus for the first time in the University's history. This phenomenon was not the result of a single lean budget year or biennium, but was an ongoing trend over the previous fifteen years, a time when both the U.S. and Ohio had undergone sustained economic growth. This trend was exacerbated in FY 2002 when Ohio State sustained an additional 6% cut in its state support as a result of a downturn in the economy.

Ohio has gone from a position sixteen years ago, when Ohio State's share of instructional support was nearly double its student fee income, to a position today where the state provides a minority share of the instructional funding for Ohio State. And, the forecast for the foreseeable future is that state support will continue to fall further behind student fee income. This will put a greater financial burden on students.

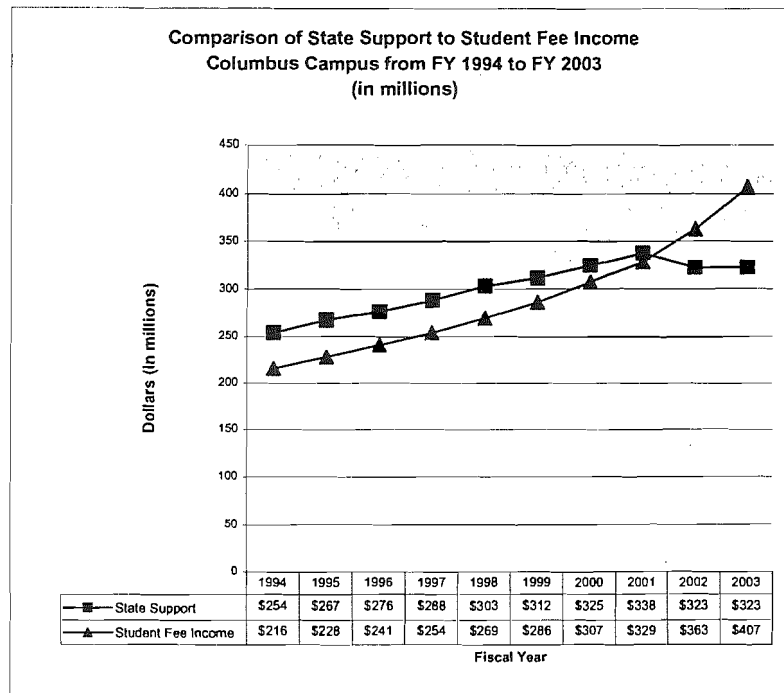

State Support

Beginning in FY 2000, the definition of state support expanded to include the state share of instruction and five new line-item appropriations considered challenge funding. Challenge funding for each university or college is dependent upon that institution's performance in meeting the following statewide goals:

Success Challenge – rewards successful completion of academic programs by at-risk students (OIG-eligible undergraduates); and successful completion of a baccalaureate degree in a timely manner (4 years).

Research Challenge - rewards success in securing sponsored research from external sources.

Priorities in Graduate Education – supports improvements in graduate programs in computer science.

Access Challenge - reduces financial barriers to entry-level higher education (two-year schools only). The reduction in access challenge will make it more difficult for the regional campuses to keep their tuition low.

Jobs Challenge - rewards successful efforts at meeting community needs for non-credit job training (two-year schools only).

State Share of Instruction - In Spring 2001, the Governor announced the need to reduce the FY 2001 operating appropriations for higher education by one percent. The total cut to OSU was \$4.5 million. The vast majority of the cut came from the State Share of Instruction. Challenge funding was held harmless from the cut. A 6% state budget reduction followed in the fall of FY 2002 cutting further the State Share of Instruction including the Challenge funding for the Columbus Campus by \$20.5 million to \$322.7 million. This cut brought the level of state support to a level approximately equivalent to FY 1999 levels of funding.

STUDENT FEES

Student Enrollments

Undergraduate student retention rates and an increase in the average number of credit hours undergraduates are taking per person along with a slightly larger freshmen class have increased undergraduate enrollment levels 1.3% above original FY 2002 projections.

Graduate enrollments began to stabilize in FY 2002 after several years of decline and are projected to remain stable and grow slightly. Professional student enrollments are projected to continue growing. Total undergraduate, graduate and professional Columbus campus enrollments for FY 2003 are projected to be 49,094, the highest projected enrollment levels since fall of 1994.

Undergraduate Instructional Fees

Columbus Campus - Beginning Summer Quarter 2002 Ohio State's Columbus Campus implemented a two-tier tuition schedule. The new two-tier approach allowed the University to keep a prior commitment to its current students that limited increases to the combined instructional and general fees to 9.0% for the next three or four years.

New full-time freshmen and transfer students pay an additional \$158 per quarter for a total increase from FY 2002 fees of 19%. Phasing in a higher tuition rate will allow the University to preserve gains already made toward the goals of the Academic Plan and to continue to improve the University's academic standing while remaining a great investment for our students and the people of Ohio.

Institution	FY 2002	FY 2003 ¹			
	Fall 01 Tuition	New Students		Continuing Students	
		Tuition	% Chg	Tuition	% Chg
Miami University	\$6,916	\$7,600	9.9%	\$7,600	9.9%
U of Cincinnati ²	5,823	6,936	19.1%	6,936	19.1%
Bowling Green ²	5,604	6,726	20.0%	6,486	15.7%
Kent State ²	5,598	6,374	13.9%	6,374	13.9%
Ohio University	5,493	6,336	15.3%	6,036	9.9%
U of Akron ²	4,930	6,098	23.7%	5,798	17.6%
U of Toledo	5,102	5,836	14.4%	5,836	14.4%
Ohio State	4,761	5,664	19.0%	5,190	9.0%
Cleveland State ²	4,464	5,496	23.1%	5,196	16.4%
Wright State ²	4,596	5,361	16.6%	5,163	12.3%
Youngstown State	4,204	4,996	18.8%	4,996	18.8%
Shawnee State ²	3,402	4,347	27.8%	4,050	19.0%
Central State	3,723	4,021	8.0%	4,021	8.0%
State Average	\$4,970	\$5,830	17.3%	\$5,668	14.0%

¹Sources are the individual institutions

²Universities implemented mid-year fee increases in FY 2002

General Fees

The general fee was restructured in FY 1995 to correspond with the costs associated with the Office of Student Affairs and includes such items as Student Unions, Student Health Center, and Student Life. The purpose of this restructuring was to improve accountability. In FY 2003, the Columbus Campus general fee will increase 2.6% to \$120 per quarter (\$180 per semester)

Graduate and Professional Fees

The combined instructional and general fees for most graduate students will increase 4.9% (\$306 per year) and full-time, non-resident graduate students will pay \$810 more per year. Non-resident surcharges vary among graduate and professional programs, but all non-resident surcharges will increase 5%.

Some graduate and professional students pay a higher or differential fee. Revenue generated from FY 2003 differential fee increases is earmarked to support the graduate and professional programs that generate the fee income.

The following graduate and professional program's differential fees for full-time graduate and professional students are effective in Autumn 2003.

FY 2003 PROFESSIONAL STUDENT FEES		
COLLEGE	RESIDENT INSTRUCTIONAL & GENERAL FEES	
	RESIDENT TOTAL (PER QUARTER)	% INCREASE OVER FY02
LAW (SEMESTER)	\$5,940	9.7%
BUSINESS MBA ¹	\$4,297	13.7%
BUSINESS EMBA	\$9,777	7.0%
BUSINESS - M OF ACCT	\$5,530	4.9%
BUSINESS MLHR	\$2,392	4.9%
DENTISTRY	\$4,783	11.8%
PUBLIC HEALTH MPH ²	\$2,303	9.6%
PUBLIC HEALTH PEP ²	\$2,343	11.5%
M OF HEALTH ADMIN. ²	\$2,700	28.4%
MEDICINE ³	\$5,804	14.8%
MEDICINE – MPT	\$2,397	9.6%
OPTOMETRY	\$3,762	4.8%
PHARMACY	\$2,870	8.6%
VETERINARY MEDICINE	\$4,396	8.7%

¹ Final year of a 4-year planned increase

² New differential fee – See table page I.3

³ The fee applies only to level 0 students. The College of Medicine will offer tuition credits that will effectively lower the annual increase to 11.8% for students in levels 1 and 2 and to 8.2% for students in level 3.

Undergraduate Non-Resident Surcharge

Effective summer quarter 2002, the undergraduate non-resident surcharge at all campuses will increase 7.5% to \$3,141 per quarter for a full-time student.

Regional Campuses and ATI

The instructional and general fees combined net of the Access Challenge credits for the regional campuses are 8.9% for the lower-division students (freshmen and sophomores) and 12.8% for the upper-division students (juniors and seniors) and 9.9% for all undergraduate students at ATI.

Technology Fees

Specific learning technology fees are earmarked for the Colleges of Engineering, Business, Arts and Nursing and the CIS program in Math & Physical Sciences and Public Policy in Social & Behavioral Sciences. All of these fees remained at the FY 2002 levels.

Residence Halls and Other Charges

Other charges to Columbus Campus students (room and board, bookstores, health insurance, etc.) will increase by an average of 5.1% for undergraduate students. Included in this weighted average is an increase in room and board charges for undergraduate residence halls that

range from 2% to 6% depending on room and meal plan selection. (See table IV. 14).

Indirect Cost Recoveries

Over the last two years, indirect cost recoveries for sponsored research were the fastest growing component of University's General Funds budget. Indirect cost recoveries grow as a function of the level of external research grants awarded to the University. The negotiated indirect cost recovery reimbursement rate is a function of the University's actual expenditures (subject to certain established ceilings) for general administrative and library support services, and research facility and equipment costs. After several years of moderate growth, indirect cost recoveries grew by 16.6% in FY 2001 and by 13.3% in FY 2002. In FY 2003, we are projecting the growth in indirect cost recoveries will level off and grow by a more typical 3.6% over FY 2002 recoveries.

Other Income

Additional sources of General Funds income include: internal overhead (\$40.2 million) paid by the University's auxiliary and earnings operations; interest income (\$10.1 million); unrestricted endowment and designated income (\$5.5 million); and miscellaneous income (\$1.0 million). Other income, in total, is projected to increase by 2.8% above the FY 2002 level to \$56.8 million.

IV. FY 2003 EXPENDITURE SUMMARY

OVERVIEW

In January, the University identified a \$73 million budget problem for FY 2003. This included \$53 million in additional resources needed to meet compensation, financial aid and other program commitments of the Academic Plan, as well as \$20 million in expenditure reductions to offset state budget cuts.

Our budget recommendations for FY 2003 meet these goals through \$48 million in new resources from tuition increases (including \$3 million in differential fees earmarked to be returned to the graduate and professional programs whose students pay the higher fees), enrollment increases and other sources, \$20 million in base spending reductions, and \$8 million in additional budget reallocations and redirections. The FY 2003 General Fund budget priorities as guided by the Academic Plan are:

Protect Student Financial Aid and Enhance the Undergraduate Experience - Financial aid funds will be increased at a rate that ensures students who are otherwise qualified will not be denied admission for

financial reasons; \$5.4 million (20%) of the growth in undergraduate tuition revenues is set aside for undergraduate student financial aid including an additional \$.5 million in the use of unrestricted endowment income. An additional \$8.7 million is budgeted to support the growth in graduate fee authorizations. The University will continue to improve access to high-demand undergraduate courses counseling and advising services, the first year experience program for freshmen, and the living learning centers.

Competitive Faculty and Staff Compensation – University-wide General Funds budgeted expenditures for faculty and staff compensation will grow by \$30.57million, including \$11.1 million in increased costs to the University share of employee benefits. The University will fund:

- Average pay increases for faculty and staff in the range of 4.5% (roughly equal to 1.0% above the market)
- Contractual pay increases for bargaining unit staff
- Estimated 12% average increase in the University share of employee benefits costs

Of the \$30.8 million, \$23.9 million is being funded by new revenues to the University and \$6.9 million by the reprogramming of current expenditures including the elimination of over 580 FTE positions throughout the University.

Provost's Strategic Investment and Rebasing Funds – consists of funding support for long-term commitments such as selective investment in top academic units, rebasing college budgets and recruitment and retention of top undergraduate students.

Differential Fees – Includes those additional funds generated by graduate and professional students paying a differential tuition. These funds are earmarked for the support of the programs in which the student's are enrolled.

University Utilities and Building Maintenance – An estimated 3.2% inflationary increase in budgeted facility costs including utilities, rent, insurance, repair and renovations is budgeted requiring an additional \$1.6 million over FY 2002 expenditures.

Other and Unfunded Mandates – An additional \$.7 million is budgeted to fund increases in the **President's Fund**, and to cover **Unfunded State and Federal Mandates**, a cost over which the University has little control.

FY 2003 Columbus Campus New General Funds Allocations (in Millions)	
Student Financial Aid & Undergraduate Student Experience	\$14.0
¹ Faculty & Staff Salary/ Benefit Increases Net Reallocations	23.9
Provost's Strategic Investment & Rebasing Funds	4.6
Differential Fees	2.9
Utilities and Bldg Maintenance	1.6
Other and Unfunded Mandates	0.8
Increase in General Funds Expenditures	\$47.8

¹Includes increase in faculty & staff salary/benefit total costs (\$30.8M) less budget reallocations (\$6.9M)

ACADEMIC PRIORITIES

Although the University will make progress on its strategic goals, during the coming year, implementation of the Academic Plan will be accomplished at a much slower pace than originally anticipated.

The primary Academic Plan initiatives on which the University will focus in FY 2003 are:

- Competitive faculty and staff compensation funded primarily through the General Funds budget;
- A series of enhancements to our undergraduate programs funded primarily through the reprogramming of existing General Funds;

- A major biomedical research initiative, funded from increased research initiatives and drawing in part upon the Tobacco Settlement funds; and
- Creation of the William E. Kirwan Institute for the Study of Race and Ethnicity in the Americas, using funds earmarked in prior years.

V. EXPENDITURE TRENDS AND MULTI-YEAR COMMITMENTS

Expenditure Trends

(All figures in millions of \$)

Following are a series of tables showing a five-year trend of budget amounts for selected priorities. They include only general fund sources unless otherwise indicated and many increases will be zero due to budget constraints.

Compensation - Over the last five years, the University has increased salaries and wages an average of 3.3% a year while benefits costs per individual have increased an average of 6.4% per year.

Compensation					
	FY 99	FY 00	FY 01	FY 02	FY 03
Salaries & Wages	\$373.10	\$391.20	\$406.30	\$419.60	\$445.20
Benefits	69.90	76.00	80.90	85.10	96.50
Total	\$443.00	\$467.20	\$487.20	\$504.70	\$541.70

Provost's Strategic Investments - The University continues to improve the academic experience of its students by investing in quality academic programs. In FY 2003, over \$12.3 million will have been invested in thirteen academic programs across the University and

nearly 90 academic enrichment initiatives. The Provost's Strategic Investment Fund also provides support for the Academic Plan priorities such as the Kirwan Institute for the Study of Race and Ethnicity in the Americas.

Provost's Strategic Investments					
	FY 99	FY 00	FY 01	FY 02	FY 03
Provost's Strategic Inv.	\$5.75	\$7.50	\$9.50	\$10.30	\$12.30
Library Support	9.80	10.40	11.10	11.70 ³	11.30
Board of Trustees Chair	0.34	0.34	0.34	0.34	0.35
Total	\$15.89	\$18.24	\$20.94	\$22.34	\$23.95

Research Support - Research continues to be a high priority of the University. Resources must continually be invested in order for the University to maintain its competitive advantage and to increase its research output. In FY 2003, total research support continues to increase in spite of no increase in Research Challenge funding. The Academic Plan and the Research Commission report continue to focus university efforts to further advance its research efforts. As a result of increased indirect cost

³ The increase in Library Support in FY 2002 is in one-time funds.

recoveries over original FY 2002 budget projections, an additional \$6.0 million is being made available for research initiatives in FY 2003. \$3.0 million will be distributed to the colleges generating the indirect costs on a proportional basis and \$3.0 million will be allocated to central research initiatives including OSURF computing, Cancer Research support, Lab Animal facilities and risk protection.

Research Support					
	FY 99	FY 00	FY 01	FY 02	FY 03
OSURF Admin	\$6.50	\$6.80	\$6.40	\$6.50	\$7.90
Special Purp. Research	4.00	4.20	4.40	4.40	2.50 ⁴
CDRS/DDRS Distribution					1.90 ⁴
Research Fee Auth	11.90	12.50	13.30	14.00	14.70
Central Research Spt ⁵					2.00
Distribution of Indirect Cost ⁶					3.00
Research Chal	6.00	7.90	9.30	8.10	8.10
Research Facilities ⁷	6.40	6.20	6.20	7.00	7.10
Total	\$34.80	\$37.60	\$39.60	\$40.00	\$45.00

⁴ Decrease represents the decentralization of the CDRS/DDRS funds to the colleges.

⁵ Half of the additional indirect cost recoveries collected in FY 2002 will be used to support OSURF computing, Cancer research, Lab Animal Facilities and risk protection.

⁶ Half of the additional indirect cost recoveries collected in FY 2002 are being returned to the colleges permanently in FY 2003.

⁷ Consists of Research Rent and Research Debt Service.

Diversity - The University must continue to invest in those areas that will have the greatest potential for a positive impact on its commitment to diversity. Additional funds to offset inflation are provided for minority scholarships. Funding is provided for a variety of new diversity initiatives listed below.

Diversity					
	FY 99	FY 00	FY 01	FY 02	FY 03
Minority Scholarships ⁸	\$8.80	\$9.20	\$10.10	\$11.20	\$12.50
Faculty Assistance	5.10	5.30	5.50	5.50	5.50
Retention & Other			0.70	0.70	0.70
Academic Prog Endow ⁹			1.00		
Initiative Seed Funds ⁹			0.30		
Multicultural Center				0.15	0.25
Women's Place				0.10	0.20
Total	\$13.90	\$14.50	\$17.70	\$17.65	\$19.15

Student Financial Aid - In FY 2003, an estimated 25,000 students will receive some form of financial aid, making this one of the most critical student services. The University will allocate additional funds (20% of new undergraduate fee revenue and nearly all of the increase in graduate fee revenue) so that scholarships

⁸ Includes Young Scholars financial aid.

⁹ Funded from Exclusive Beverage Contract.

and fee authorizations can be increased to offset increases in student fees.

Student Financial Aid					
	FY 99	FY 00	FY 01	FY 02	FY 03
Scholarships	\$6.70	\$7.10	\$7.80	\$7.65	\$10.70
Buckeye Scholarships	2.70	4.50	6.10	6.95	6.80
High Ability Scholars	5.30	5.60	5.50	6.75	9.00
Fee Authoriz.	58.10	59.00	59.80	67.80	78.70
Total	\$72.80	\$76.20	\$79.20	\$89.15	\$105.20

Physical Environment - The Ohio State University faces a backlog of over \$100 million in identified maintenance needs for campus facilities. While this backlog cannot be eliminated overnight, the University continues to invest significant resources to maintain the campus physical environment.

Physical Environment					
	FY 99	FY 00	FY 01	FY 02	FY 03
Renovations (State)	\$7.70	\$7.70	\$7.70	\$7.70	¹⁰ TBD
University (Cont.) ¹¹	6.90	6.90	7.00	7.20	7.40
University (1-time)	1.70	1.00	0.50	1.30	0
Total	\$16.30	\$15.60	\$15.20	\$16.20	TBD

¹⁰ State capital appropriations for FY2003 not yet finalized.

¹¹ Repair & Renovation and the Space Facilities Committee Reserve.

Instructional Technology - The University has embarked on a multi-year effort to increase support of learning technology. It is critical to the University's mission that faculty, staff and students have access to the most advanced technologies.

Instructional Technology					
	FY 99	FY 00	FY 01	FY 02	FY 03
Academic Computing (Cont)	\$8.48	\$9.18	\$8.72	\$10.37	\$10.30
Academic Computing (1-Time)	0.80	0.80	1.00	0	0
College & Program Computer Fees					
Engineering/CIS	1.30	1.30	1.30	1.30	1.40
Business	0.80	0.80	0.80	0.80	0.95
Public Policy	0.03	0.03	0.03	0.03	0.03
Arts	0	0	0.20	0.20	0.25
Nursing	0	0	0.10	0.10	0.06
Total	\$11.41	\$12.11	\$12.15	\$12.80	\$12.99

Multi-Year Commitments

(All figures in millions of \$)

The documentation of multi-year commitments has been part of the annual budget document every year since FY 1996. The purpose of this review is to share with the campus a sense of what these commitments are and how they change from year to year. In order to plan effectively, the University needs to be able to make commitments across fiscal years, but do so in a way that does not jeopardize future financial flexibility.

Multi-year commitments are divided into five categories to reflect the various sources of the funds to address these commitments. These categories are:

- Continuing central General Funds
- One-time central General Funds
- Central Non-General Funds
- Colleges and support units' funds
- Capital funds

Central Continuing General Funds

The following table lists the explicit multi-year commitments against continuing General Funds. The Provost's Strategic Investment Fund and Enhanced Recruiting are a continuation of existing commitments. Campus Partners continuing General Fund commitments include projected increased rental costs for the move of Human Resources and other units into Gateway in FY 2004. Graduate Associate health

insurance is a three-year commitment to fund a portion of student health insurance for graduate assistants.

Multi-Year Continuing General Funds					
Commitment	Init'l FY	FY02 Total	FY03 New	FY 04 Est Inc	FY 05 Est Inc
Provost Strategic Invest	1995	\$10.3	\$2.0	\$2.0	\$2.0
Recruit Enhance	1998	3.0	0.4	0.0	0.0
Campus Partners	1995	0.2	0.0	0.5-1.0	0.0
Grad Assoc. Health Ins	2002	0.5	0.5	0.5	0.0
Budget Rebasing	2002	0.8	2.0	2.0	2.0

In accordance with the Academic Plan and the principles of Budget Restructuring, it was determined that some colleges' base budgets were not in alignment with the goals of the Academic Plan. The table below documents the rebasing transfers to and from these colleges over a five-year period beginning in FY 2002.

Budget Rebasing Transfers (in millions)			
College	FY 2002	FY 2003	5 Year Goal
Transfers to Colleges			
Humanities	\$0.42	\$0.58	\$2.50-\$4.40
[†] Medicine	0.00	4.00	4.70
Social & Behavioral Sciences	0.17	0.30	1.10
Biological Sciences	0.09	0.20	0.60
Optometry	0.08	0.07	0.40
Social Work	0.05	0.11	0.30
Human Ecology	0.04	0.14	0.20
Subtotal	0.85	5.40	9.80-11.70
Transfers from Colleges			
Nursing		(0.02)	(0.10-0.30)
Pharmacy		(0.02)	(0.35-0.85)
Dentistry		(0.25)	(1.25-2.15)
Subtotal		(0.29)	(1.70-3.30)
Net Transfers	\$0.85	\$5.11	\$6.50-\$10.00

[†]Rebasing resources equal \$1M in continuing funds and \$3M in one-time funds. A total of \$4.7M in continuing rebasing funds to be transferred through FY 2006. The total amount is subject to further refinement due to space cost issues

The desired ceiling for multi-year commitments is that commitments in the succeeding three years not exceed 1% of the current year's budget. This guideline was established in the mid 1990's in order to preserve future financial flexibility. One percent of the FY 2003 Columbus Campus General Funds Budget is \$8.2 million. The total of new FY03 multi-year commitments plus future obligations in FY 2004 and FY 2005 ranges between \$8.5 and \$12.0 million primarily as a result of adding Budget Rebasing

commitments. Therefore, caution needs to be exercised in making additional future multi-year commitments until the University's financial picture improves.

In addition to the specific multi-year commitments listed above, the University will continue to need to fund increases in a number of areas of the General Funds budget. These include:

- Competitive annual compensation increases for faculty, staff and student employees
- Continuing needs for increases in supplies
- Implementation of the G-QUE and I-QUE recommendations
- Support of research
- Deferred maintenance and other capital needs
- Academic and administrative computing needs
- Student Financial Aid
- Unfunded legal mandates
- Diversity and Outreach
- Other Academic Plan initiatives

Commitments of Central One-Time General Funds

The commitment for the Trustees' Chair is the fourth year of a five-year commitment. In July 2000, the new automated General Ledger (GL) System was successfully implemented including adjustments to the Procurement and Human Resources Systems. An internal loan needed to complete this initiative will be paid off by FY 2003. Responsibility for the operation and maintenance of the GL, Procurement and Human

Resources Systems has been integrated into the University's existing OIT organization.

Central One-Time General Funds					
Commitment	Initial FY	FY 02 Actual	FY 03 Est Inc	FY 04 Est Inc	FY 05 Est Inc
PharmD Support	1998	\$0.14	\$0.14	\$0	\$0
Trustees' Chair	1999	0.34	0.34	0.10	0
Internal Loan Repayment	2001	7.00	7.00	0	0
OIT Support	2002	3.00	1.00	0	0

In October 2000, the University Board of Trustees approved the creation of the President's Strategic Investment Fund. The purpose of this fund is to allow the President to direct one-time resources into areas of strategic investment supportive of the Academic Plan.

Resources for the Strategic Investment Fund come from both general funds freed up by moving Development off the General Fund and from Research Challenge. These are one-time funds only. The Board resolution prohibits use of these resources for continuing commitments. Use of these funds is at the President's discretion and must be reported annually to the Board of Trustees. Commitments to date total \$24.89 million are distributed as identified in the following table.

President's Strategic Investment Fund						
	Base	FY03	FY04	FY05	FY06	Total
Micro MD	\$5.70					\$5.70
Medical Informatics	1.50	1.25	1.25			4.00
P-12 Initiative	.20	.20	.20	.20		.80
World Class Faculty		.38				.38
Library Acq.	.71					.71
Grad. Recruit	.36					.36
Math, BioSci	.20					.20
COMPH Pharmacology				.93	.92	1.85
Biomed Resch Tower ¹²			2.40	1.80	.80	5.00
Outreach & Engagement	.19	.15	.15			.49
Tech Transfer		.80	.80	.80		2.40
Undergrad Experience		1.00	1.00	1.00		3.00
Total	\$8.86	\$3.78	\$5.80	\$4.73	\$1.72	\$24.89

Central Commitments of Non-General Funds

As the University moves to diversify its funding sources, the commitment of non-General Fund sources is becoming much more significant. The following table lists ongoing commitments of non-General Fund sources that are primarily endowment and unrestricted gift money.

¹² Does not include \$3.0 million from FY 2002 indirect cost recoveries.

Central Commitments Non-General Funds			
Project	Total	Source	Time Frame
Campus Partners	\$25.0	Endowment	97-02
	5.8	Unrest Gift	95-05
Science & Tech Campus Oper.	2.7	Ofc of Research	03-12
Science & Tech Campus Loan	21.0	Endowment	97-22

College and Other Unit Commitments

As the University moves to a more decentralized structure, colleges and other administrative units will be taking on greater financial responsibility. The section below lists specific initiatives where colleges and large administrative units have been given or have given loans to accomplish certain objectives.

New commitments are 1) Olympic Sports – Athletics has been authorized to proceed with planning for a capital campaign to build a series of facilities related to Olympic sports. 2) ULAR is proceeding with a 25,000 square foot addition and expansion of facilities to be funded from several sources including State Capital Appropriations, NIH Grants and bonds, which will be paid off from indirect cost recoveries. It should be noted that Prologue Inc. has been fully funded and has been taken off the list. Remaining commitments include:

College and Other Unit Commitments				
Project	College/ Unit	Total	Source ¹³	Time Frame
Med Ohio Health, Inc.	Health System	\$5.60	Patient Revenues	95-06
Telescope project	MAPS	0.50	Cost Recoveries	98-04
Heart & Lung Inst. Addit. Construction Operating	Medicine	0.63 0.13	Cost Recoveries	98-13
MRI	Medicine	1.50	Cost Recoveries	99-05
Ohio Stadium	Athletics	195.00	Tickets, Club Seats, Boxes	99-29
Schottenstein Center	Student Affairs	55.20	Ticket Sales	99-29
Heart Hospital	Health System	82.60	Patient Revenues	01-21
Micro MD Bio Mems	Central Research Medicine Engineer	4.50 1.50 1.50 1.50	Strat. Invst Various Various Various	01-21
Executive Residence	Business	31.00	Rental Revenues	02-33
Bio-Med Research Fac.	Medicine	TBD	Cost Recoveries	05-25
Olympic Sports	Athletics	45.0	Capital Campaign	03-?
Lab Animal	ULAR	8.2	Cost Recovr	03-18

¹³ Increases in cost recoveries are guaranteed by the respective college and/or department

In addition to these specific multi-year commitments by the colleges, we want to highlight some of the financial issues facing The Ohio State University Medical Center and the Department of Athletics.

The Ohio State University Medical Center is the most comprehensive in the country. It currently is facing three financial challenges: 1) the competitive challenges presented by managed care, 2) the competitive challenge for research dollars and 3) the recent purchase of Park Hospital to create University Hospitals East. Recent hires in the area of medical research will provide an enormous competitive advantage in cancer, heart and lung, and biomedical research. However, these new hires will also require a corresponding significant investment of financial support. Initial support has been made possible by the transfer of funds from past successful operations of the James Cancer Hospital and Solove Research Institute, and now the President's Strategic Reserve among other sources.

The pressures of responding to managed-care competition are likely to continue. The Ohio State University Medical Center accounts for nearly 40% of the entire OSU budget from all sources. While The Ohio State University Medical Center is currently in a positive financial position, the ability to remain strong academically and financially depends on the ability of the University and the Medical Center to balance internal demands for more resources in support of

teaching and research against external market forces centered primarily on cost.

The Ohio State University's Athletics' program is the largest in the country and one of only a handful that contributes resources back to the University. The program has aggressively embarked on an effort to correct a number of chronic problems that have needed attention for quite some time, including inadequate facilities, equity issues in coaches' pay and Title IX compliance. Facility investments alone resulted in a quarter of a billion dollar commitment over the last few years. While the program is still financially sound, future revenue growth is not guaranteed. It is essential that new commitments be carefully balanced against future resources so that the program remains financially viable.

Capital

Capital commitments were addressed as part of the preparation for the Biennial Capital Request, and thus will not be dealt with in great detail here. However, we would like to emphasize the following:

- Most of the University's capital needs for replacement and renewal of existing academic building space must be met through the State capital funding process.
- Even if state support remains constant or grows slightly, the University will need to make a commitment in additional continuing funds to address deferred maintenance problems

(\$250,000-\$500,000 per year for the next 3-5 years).

- Capital needs in Athletics and the Medical Center should be balanced against operating needs and expected income sources, as discussed previously.
- Although adequate funds are available to meet the needs described above, existing funding sources are not sufficient to embark on additional major university financed construction projects without additional funding sources.
- Although issuing tax-exempt bonds has been a popular funding source over the years, the University has only a finite capacity to issue bonds before negatively impacting its strong credit rating.

Maintaining a high rating will keep us from paying higher interest rates. Thus, we need to carefully manage the amount of bonds issued in the future.

Conclusions

Financial projections show that if present trends continue, the University will have sufficient funds to cover its commitments, but will not have discretionary funds available to embark on other significant new initiatives. Thus, if any new initiatives are desired or existing initiatives expanded, the University needs to reduce other commitments or secure additional funds.

SELECTED DEFINITIONS

Current Funds are those funds that are earned and expended in the current fiscal year. They include the General Fund, Earnings Operations and Restricted Funds. Excluded entirely from this report are Non-Current Funds such as Plant Funds, Loan Funds and Endowment Principal.

General Funds are unrestricted resources available for allocation in support of core instruction; instructional support and related general administrative and physical plant expenditures.

Earnings Operations are also unrestricted with resources generated from the sales and services of the earnings units. While not a requirement, these resources are generally designated to the unit generating the revenue. Included are the Hospitals & CHRI, Auxiliaries and departmental earnings units.

Auxiliaries are specifically identified by the State as the following earnings operations: Residence & Dining Halls, Intercollegiate Athletics, Student Unions, Bookstores, Traffic & Parking, Fawcett Center, University Airport and Property Management.

Unrestricted refers to the sum of general funds plus earnings operations.

Restricted Funds are funds whose use has been designated by an external agency or individual and limited to support a specific purpose and/or unit. Included is Sponsored Programs.

Instruction and Departmental Research includes all direct and applicable allocated expenditures for all activities that are part of the University's instructional program. It includes expenditures for departmental research and public service that are not separately budgeted.

Academic Support includes all funds expended for activities carried out primarily to provide support services that are an integral part of the operations of one of the three primary missions - instruction, research and public service. Included in this category are Academic Affairs Administration, Libraries, Museums & Galleries and the Deans' offices,

Student Services includes funds expended for those activities whose primary purpose is to contribute to students' emotional and physical well being, as well as their cultural and social development outside the context of the formal

instructional program. Included in this category are Admissions and Registration, Counseling, Student Health Service, Recreation & Intramural Sports, Student Financial Aid and the Student unions.

Institutional Support contains expenditures for operations that provide support services to the total University. Included in this category are Executive Management, Business and Finance, Human Resources, University Relations and Development.

Plant, Operations and Maintenance includes all expenditures of current funds for the operation and maintenance of the physical plant, net of amounts charged to auxiliary operations and hospitals. Included in this category are utilities, repair and renovations, custodial services, grounds maintenance, space rental and property insurance.

Separately Budgeted Research includes all expenditures for activities specifically organized to produce research outcomes, whether

commissioned by an external agency to the University (restricted) or the University (unrestricted) and includes matching funds applicable to the conditions set forth by the grant or contract. It does not include training grants or equipment grants.

Public Service includes all funds expended for activities that are established primarily to provide non-credit designated course offerings and services beneficial to individuals and groups external to the University. Included in this category are Continuing Education and Cooperative Extension Services.

Scholarships and Fellowships include expenditures in the form of outright grants and trainee stipends to individuals enrolled in formal coursework, either for credit or non-credit.

One-Time Funds are cash payments made to colleges and departments on a discretionary basis. The source of the funds is the cash balance carried forward from the previous year.

**SUMMARY OF BUDGETED RESOURCES AND EXPENDITURES
TOTAL UNIVERSITY
(IN THOUSANDS)**

	2001-02 Revised Budget	2002-03 Budget	Dollar Change	Percent Change
RESOURCES				
Government Support				
State	477,042	478,362	1,320	0.3%
Federal	212,698	228,193	15,495	7.3%
Local	23,817	24,585	768	3.2%
Subtotal Government Support	713,557	731,139	17,582	2.5%
Student Fees				
Instructional, General & Tuition	386,678	433,624	46,946	12.1%
Other	21,676	22,487	811	3.7%
Subtotal Student Fees	408,354	456,111	47,757	11.7%
Other Resources				
Health System (1)	672,403	828,517	156,114	23.2%
Auxiliaries	170,079	188,217	18,138	10.7%
Departmental Sales & Services	70,854	80,907	10,053	14.2%
Private Grants & Contracts	174,643	224,739	50,096	28.7%
Other	59,018	38,607	(20,411)	-34.6%
Subtotal Other Resources	1,146,997	1,360,987	213,990	18.7%
Total Resources	2,268,908	2,548,237	279,329	12.3%
EXPENDITURES				
Instructional & General	930,924	989,846	58,922	6.3%
Separately Budgeted Research	280,504	307,540	27,036	9.6%
Public Service	105,837	110,652	4,815	4.5%
Scholarships & Fellowships	99,264	110,149	10,885	11.0%
Auxiliaries	177,343	196,539	19,196	10.8%
Health System (1)	680,232	831,626	151,394	22.3%
Total Expenditures	2,274,104	2,546,352	272,248	12.0%

(1) Health Systems budget includes University Hospital, Hospital East, CHRI, Harding and Networks.
The FY 2002 budget was revised down \$52.6 million to eliminate inter hospital transfers.

SUMMARY OF BUDGETED RESOURCES AND EXPENDITURES TOTAL UNIVERSITY - FY 2003

RESOURCES BY SOURCE

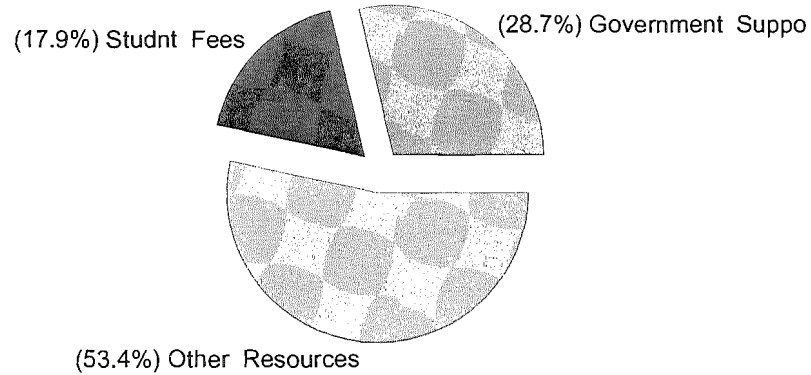

EXPENDITURES BY FUNCTION

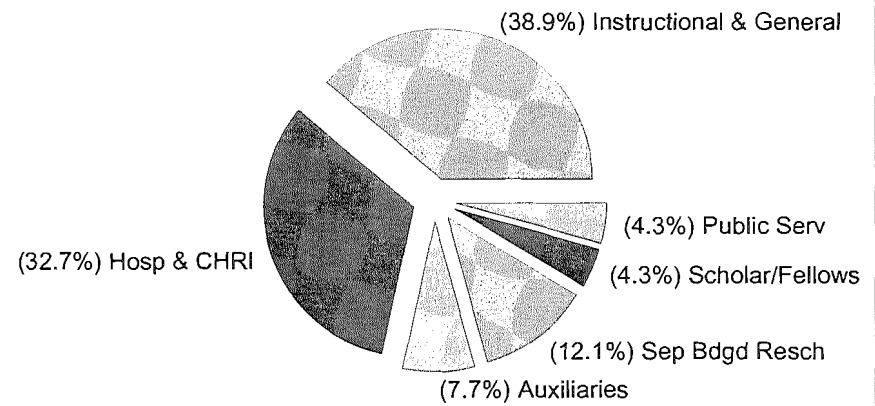

SUMMARY OF ANNUAL STUDENT FEES COLUMBUS CAMPUS

		INSTRUCTIONAL & GENERAL FEES				NONRESIDENT SURCHARGE			
		FY 2002 Fees	FY 2003 Fees	Dollar Change	Percent Change	FY 2002 Fees	FY 2003 Fees	Dollar Change	Percent Change
Undergraduate:									
Continuing Students	(1)	4,761	5,190	429	9.0%	8,766	9,423	657	7.5%
New Students	(1)	4,761	5,664	903	19.0%	8,766	9,423	657	7.5%
Graduate Programs:									
Graduate		6,306	6,612	306	4.9%	10,071	10,575	504	5.0%
MLHR		6,843	7,176	333	4.9%	10,071	10,575	504	5.0%
MBA		11,334	12,891	1,557	13.7%	10,071	10,575	504	5.0%
EMBA		27,402	29,331	1,929	7.0%	10,071	10,575	504	5.0%
Master of Accounting		15,810	16,590	780	4.9%	10,071	10,575	504	5.0%
Health Administration	(2)	6,306	8,100	1,794	28.4%	10,071	10,575	504	5.0%
Public Health MPH	(2)	6,306	6,909	603	9.6%	10,071	10,575	504	5.0%
Public Health PEP	(2)	6,306	7,029	723	11.5%	10,071	10,575	504	5.0%
Master of Physical Therapy		6,561	7,191	630	9.6%	10,071	10,575	504	5.0%
Professional:									
Pharmacy		7,716	8,610	894	11.6%	10,716	11,250	534	5.0%
Dentistry		12,840	14,349	1,509	11.8%	20,688	21,720	1,032	5.0%
Optometry		10,374	11,286	912	8.8%	20,688	21,720	1,032	5.0%
Veterinary Medicine		12,012	13,188	1,176	9.8%	21,381	22,449	1,068	5.0%
Law		10,826	11,880	1,054	9.7%	10,876	11,420	544	5.0%
Medicine	(3)	15,168	17,412	2,244	14.8%	22,065	23,169	1,104	5.0%

Notes:

Full time fees for Undergraduate Students are for 12+ credit hours.
Full time fees for Graduate and Professional Students are for 10+ credit hours.

- (1) For the first time, undergraduate fees are broken out between continuing and new students.
- (2) These are existing programs that will have differential fees greater than the graduate fee for the first time.
- (3) Medicine will offer tuition credits to students in levels 1, 2 & 3 bringing their effective instructional fee increases to 11.8% for levels 1 & 2, and 8.2% for level 3.

DETAIL OF BUDGETED RESOURCES AND EXPENDITURES
TOTAL UNIVERSITY BY FUND
 (\$ IN THOUSANDS)

	2001-02	2002-2003			Total Budget	Percent Change
	Revised Budget	General	Earnings	Restricted		
RESOURCES						
Government Support						
State Support						
State Share of Instruction	326,628	326,628			326,628	
Appropriations	114,353	21,384		92,969	114,353	
Ohio Grants & Contracts	36,061	1,470		35,911	37,381	3.7%
Subtotal State Support	477,042	349,482		128,880	478,362	0.3%
Federal Grants & Contracts	212,698	40,421		187,772	228,193	7.3%
Local Grants & Contracts	23,817	3,535		21,050	24,585	3.2%
Subtotal Government	713,557	393,437		337,702	731,139	2.5%
Student Fees						
Instructional, General and Tuition	386,678	433,624			433,624	12.1%
Other	21,676	13,458	9,029		22,487	3.7%
Subtotal Student Fees	408,354	447,082	9,029		456,111	11.7%
Other Resources						
Health System	(1) 672,403		828,517		828,517	23.2%
Auxiliary Sales & Services	170,079		188,217		188,217	10.7%
Departmental Sales & Services	70,854		80,907		80,907	14.2%
Private Grants & Contracts	174,643	9,844		214,895	224,739	28.7%
Endowment Income	(2) 39,005	5,300		15,667	20,967	-46.2%
Investment Income	12,844	11,657		50	11,707	-8.9%
Other	7,169	5,796	137		5,933	-17.2%
Subtotal Other	1,146,997	32,597	1,097,778	230,612	1,360,987	18.7%
Total Resources	2,268,908	873,116	1,106,807	568,314	2,548,237	12.3%
EXPENDITURES						
Instruction & General	(3)					
Instruction & Departmental Research	598,490	478,142	43,055	91,008	612,205	2.3%
Academic Support	112,318	96,263	10,761	12,757	119,781	6.6%
Student Services	52,230	56,096	6,843	1,575	64,514	23.5%
Institutional Support	77,234	90,514	9,623	12,395	112,532	45.7%
Plant, Operations & Maintenance	90,652	73,954	76	6,784	80,814	-10.9%
Subtotal Instruction & General	930,924	794,969	70,358	124,519	989,846	6.3%
Separately Budgeted Research	280,504	16,627	10,587	280,326	307,540	9.6%
Public Service	105,837	6,479	13,550	90,623	110,652	4.5%
Scholarships & Fellowships	99,264	54,653		55,496	110,149	11.0%
Auxiliaries	177,343		188,689	7,850	196,539	10.8%
Health System	(1) 680,232		822,126	9,500	831,626	22.3%
Total Expenditures	2,274,104	872,728	1,105,310	568,314	2,546,352	12.0%

(1) Health Systems budget includes University Hospital, Hospital East, CHRI, Harding and Networks. The FY 2002 budget was revised down \$52.6 million to eliminate inter hospital transfers.

(2) Restricted Endowment reflects reclassification of some revenue to Private Grants & Contracts.

(3) General funds expenditures reflects a new budgeting methodology whereby the budget more closely tracks expenditures in accordance with the financial statements.

**DETAIL OF BUDGETED RESOURCES AND EXPENDITURES
COLUMBUS CAMPUS BY FUND
(IN THOUSANDS)**

	2001-02 Revised Budget	2002-2003			Total Budget	Percent Change
		General	Earnings	Restricted		
RESOURCES						
Government Support						
State Support						
State Share of Instruction	305,389	305,389			305,389	
Appropriations	73,867	18,250		55,617	73,867	
Ohio Grants & Contracts	35,136	1,470		35,000	36,470	3.8%
Subtotal State Support	414,392	325,109		90,617	415,726	0.3%
Federal Grants & Contracts	200,694	40,421		175,000	215,421	7.3%
Local Grants & Contracts	23,724	3,535		21,000	24,535	3.4%
Subtotal Government	638,810	369,064		286,617	655,681	2.6%
Student Fees						
Instructional, General and Tuition	363,054	407,433			407,433	12.2%
Other	19,890	12,790	8,200		20,990	5.5%
Subtotal Student Fees	382,944	420,223	8,200		428,423	11.9%
Other Resources						
Health System (1)	672,403		828,517		828,517	23.2%
Auxiliary Sales & Services	169,975		188,117		188,117	10.7%
Departmental Sales & Services	67,700		77,000		77,000	13.7%
Private Grants & Contracts	169,800	9,844		210,000	219,844	29.5%
Endowment Income (2)	38,375	5,300		15,000	20,300	-47.1%
Investment Income	11,300	10,600			10,600	-6.2%
Other	6,561	5,295			5,295	-19.3%
Subtotal Other	1,136,114	31,039	1,093,634	225,000	1,349,673	18.8%
Total Resources	2,157,868	820,326	1,101,834	511,617	2,433,777	12.8%
EXPENDITURES						
(3) Instruction & General						
Instruction & Departmental Research	568,111	451,155	41,868	90,000	583,023	2.6%
Academic Support	102,241	89,577	9,358	9,700	108,635	6.3%
Student Services	47,864	49,336	6,807	1,517	57,660	20.5%
Institutional Support	70,523	84,099	9,375	12,000	105,474	49.6%
Plant, Operations & Maintenance	80,462	69,215		1,750	70,965	-11.8%
Subtotal Instruction & General	869,201	743,382	67,408	114,967	925,757	6.5%
Separately Budgeted Research	239,331	16,627	10,587	239,300	266,514	11.4%
Public Service	104,111	6,334	11,852	90,000	108,186	3.9%
Scholarships & Fellowships	93,801	53,983		50,000	103,983	10.9%
Auxiliaries	177,260		188,591	7,850	196,441	10.8%
Health System (1)	680,232		822,126	9,500	831,626	22.3%
Total Expenditures	2,163,936	820,326	1,100,564	511,617	2,432,507	12.4%

(1) Health Systems budget includes University Hospital, Hospital East, CHRI, Harding and Networks. The FY 2002 budget was revised down \$52.6 million to eliminate inter hospital transfers.

(2) Restricted Endowment reflects reclassification of some revenue to Private Grants & Contracts.

(3) General funds expenditures reflects a new budgeting methodology whereby the budget more closely tracks expenditures in accordance with the financial statements.

BUDGETED RESOURCES

COLUMBUS CAMPUS - FY 2003

RESOURCES BY FUND

GENERAL FUNDS BY SOURCE

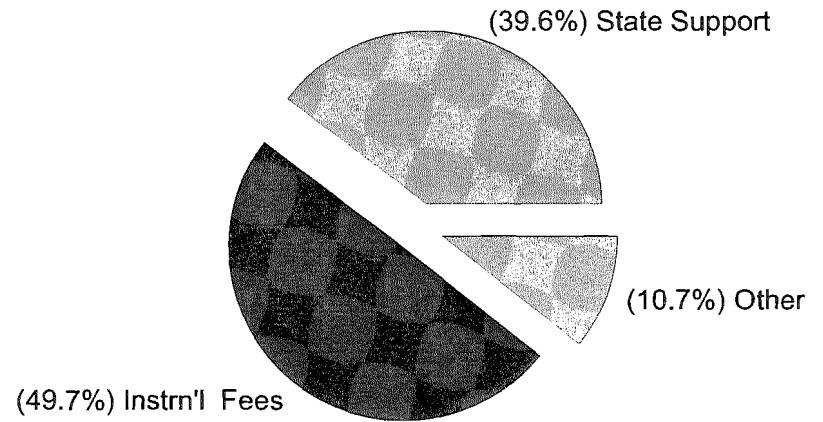
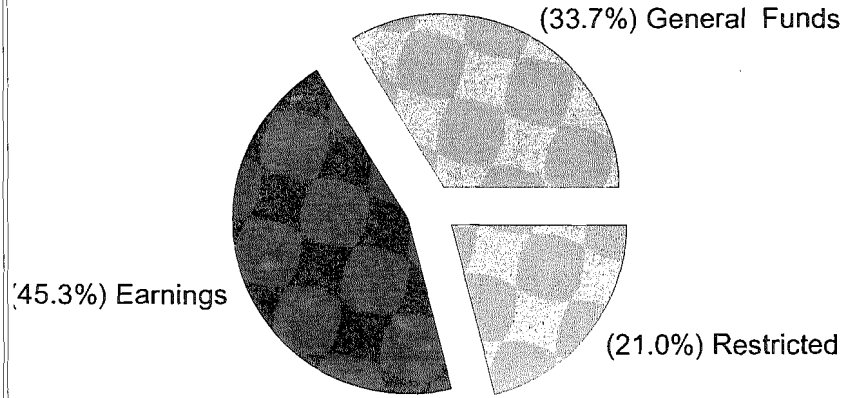

DETAIL OF BUDGETED RESOURCES AND EXPENDITURES
LIMA CAMPUS BY FUND
(IN THOUSANDS)

2001-02 Revised Budget	2002-2003			Total Budget	Percent Change
	General	Earnings	Restricted		

RESOURCES

Government Support
State Support

State Share of Instruction
Appropriations
Ohio Grants & Contracts
Subtotal State Support
Federal Grants & Contracts
Local Grants & Contracts
Subtotal Government

3,956	3,956			3,956	
850	672		178	850	
109			109	109	
4,915	4,628		287	4,915	
750			800	800	6.7%
5,665	4,628		1,087	5,715	0.9%

Student Fees

Instructional, General and Tuition
Other
Subtotal Student Fees

4,484	5,170			5,170	15.3%
997	330	829		1,159	16.2%
5,481	5,500	829		6,329	15.5%

Other Resources

Health System
Auxiliary Sales & Services
Departmental Sales & Services
Private Grants & Contracts
Endowment Income
Investment Income
Other
Subtotal Other

2		2		2	
77		192		192	149.4%
70			40	40	-42.9%
85			60	60	-29.4%
260	150			150	-42.3%
208	120	137		257	23.6%
702	270	331	100	701	-0.1%

Total Resources

11,848	10,398	1,160	1,187	12,745	7.6%
--------	--------	-------	-------	--------	------

EXPENDITURES

Instruction & General

Instruction & Departmental Research
Academic Support
Student Services
Institutional Support
Plant, Operations & Maintenance
Subtotal Instruction & General

(1)

5,606	5,525		95	5,620	0.2%
1,269	1,368		25	1,393	9.8%
984	1,418		25	1,443	46.6%
1,072	1,151	235	35	1,421	32.6%
971	749			749	-22.9%
9,902	10,211	235	180	10,626	7.3%

Separately Budgeted Research
Public Service
Scholarships & Fellowships
Auxiliaries
Health System

34			34	34	
905	116	923	65	1,104	22.0%
958			908	908	-5.2%
2		2		2	

Total Expenditures

11,801	10,327	1,160	1,187	12,674	7.4%
--------	--------	-------	-------	--------	------

(1) Student Services increases are due primarily to a correction in the way the Regional Campus Service Charge is allocated based on the Columbus Campus costs built into the calculation.

DETAIL OF BUDGETED RESOURCES AND EXPENDITURES
MANSFIELD CAMPUS BY FUND
(IN THOUSANDS)

	2001-02	2002-2003			Total Budget	Percent Change
	Revised Budget	General	Earnings	Restricted		
RESOURCES						
Government Support						
State Support						
State Share of Instruction	4,165	4,165			4,165	
Appropriations	991	726		265	991	
Ohio Grants & Contracts	238			263	263	10.5%
Subtotal State Support	5,394	4,891		528	5,419	0.5%
Federal Grants & Contracts	885			1,072	1,072	21.1%
Local Grants & Contracts	38					-100.0%
Subtotal Government	6,317	4,891		1,600	6,491	2.8%
Student Fees						
Instructional, General and Tuition	4,946	5,215			5,215	5.4%
Other	235	80			80	-66.0%
Subtotal Student Fees	5,181	5,295			5,295	2.2%
Other Resources						
Health System						
Auxiliary Sales & Services	45		45		45	
Departmental Sales & Services	26		456		456	1653.8%
Private Grants & Contracts	273			119	119	-56.4%
Endowment Income	71			95	95	33.8%
Investment Income	420	336			336	-20.0%
Other						
Subtotal Other	835	336	501	214	1,051	25.9%
Total Resources	12,333	10,522	501	1,814	12,837	4.1%
EXPENDITURES						
Instruction & General						
Instruction & Departmental Research	5,834	5,384	13	145	5,542	-5.0%
Academic Support	1,210	1,325		12	1,337	10.5%
Student Services	714	1,286	18	25	1,329	86.1%
Institutional Support	1,089	1,147		74	1,221	12.1%
Plant, Operations & Maintenance	894	789	70	32	891	-0.3%
Subtotal Instruction & General	9,741	9,931	101	288	10,320	5.9%
Separately Budgeted Research	115			80	80	-30.4%
Public Service	466	29	355	71	455	-2.4%
Scholarships & Fellowships	1,625	520		1,375	1,895	16.6%
Auxiliaries	26		45		45	73.1%
Health System						
Total Expenditures	11,973	10,480	501	1,814	12,795	6.9%

(1)

DETAIL OF BUDGETED RESOURCES AND EXPENDITURES
MARION CAMPUS BY FUND
(IN THOUSANDS)

	2001-02 Revised Budget	2002-2003			Total Budget	Percent Change
		General	Earnings	Restricted		
RESOURCES						
Government Support						
State Support						
State Share of Instruction	3,461	3,461			3,461	
Appropriations	544	537		7	544	
Ohio Grants & Contracts	58			19	19	-67.2%
Subtotal State Support	4,063	3,998		26	4,024	-1.0%
Federal Grants & Contracts	514			700	700	36.2%
Local Grants & Contracts						
Subtotal Government	4,577	3,998		726	4,724	3.2%
Student Fees						
Instructional, General and Tuition	4,375	5,494			5,494	25.6%
Other	62	68			68	9.7%
Subtotal Student Fees	4,437	5,562			5,562	25.4%
Other Resources						
Health System						
Auxiliary Sales & Services	4					-100.0%
Departmental Sales & Services	449		604		604	34.5%
Private Grants & Contracts	360			646	646	79.4%
Endowment Income	149			205	205	37.6%
Investment Income	384	261		50	311	-19.0%
Other	66	66			66	
Subtotal Other	1,412	327	604	901	1,832	29.7%
Total Resources	10,426	9,887	604	1,627	12,118	16.2%
EXPENDITURES						
Instruction & General						
Instruction & Departmental Research	4,829	4,531	546	57	5,134	6.3%
Academic Support	1,405	1,691			1,691	20.4%
Student Services	805	1,443	18		1,461	81.5%
Institutional Support	1,045	1,215		80	1,295	23.9%
Plant, Operations & Maintenance	681	772	6		778	14.2%
Subtotal Instruction & General	8,765	9,652	570	137	10,359	18.2%
Separately Budgeted Research	50					-100.0%
Public Service	180			147	147	-18.3%
Scholarships & Fellowships	1,195	150		1,343	1,493	24.9%
Auxiliaries	4					-100.0%
Health System						
Total Expenditures	10,194	9,802	570	1,627	11,999	17.7%

(1)

**DETAIL OF BUDGETED RESOURCES AND EXPENDITURES
NEWARK CAMPUS BY FUND
(IN THOUSANDS)**

	2001-02 Revised Budget	2002-2003			Total Budget	Percent Change
		General	Earnings	Restricted		
RESOURCES						
Government Support						
State Support						
State Share of Instruction	5,142	5,142			5,142	
Appropriations	1,127	782		345	1,127	
Ohio Grants & Contracts	20			20	20	
Subtotal State Support	6,289	5,924		365	6,289	
Federal Grants & Contracts	800			1,000	1,000	25.0%
Local Grants & Contracts						
Subtotal Government	7,089	5,924		1,365	7,289	2.8%
Student Fees						
Instructional, General and Tuition	6,584	6,836			6,836	3.8%
Other	190	190			190	
Subtotal Student Fees	6,774	7,026			7,026	3.7%
Other Resources						
Health System						
Auxiliary Sales & Services	53		53		53	
Departmental Sales & Services						
Private Grants & Contracts	50			40	40	-20.0%
Endowment Income	45			52	52	15.6%
Investment Income	405	285			285	-29.6%
Other	255	243			243	-4.7%
Subtotal Other	808	528	53	92	673	-16.7%
Total Resources	14,671	13,478	53	1,457	14,988	2.2%
EXPENDITURES						
Instruction & General						
Instruction & Departmental Research	7,644	7,136		211	7,347	-3.9%
Academic Support	1,573	1,496			1,496	-4.9%
Student Services	1,327	1,765		5	1,770	33.4%
Institutional Support	1,582	1,768		76	1,844	16.6%
Plant, Operations & Maintenance	1,321	1,270			1,270	-3.9%
Subtotal Instruction & General	13,447	13,435		292	13,727	2.1%
Separately Budgeted Research	24			15	15	-37.5%
Public Service						
Scholarships & Fellowships	995			1,150	1,150	15.6%
Auxiliaries	51		51		51	
Health System						
Total Expenditures	14,517	13,435	51	1,457	14,943	2.9%

DETAIL OF BUDGETED RESOURCES AND EXPENDITURES
AGRICULTURAL TECHNICAL INSTITUTE BY FUND
(IN THOUSANDS)

	2001-02 Revised Budget	2002-2003			Total Budget	Percent Change
		General	Earnings	Restricted		
RESOURCES						
Government Support						
State Support						
State Share of Instruction	4,515	4,515			4,515	
Appropriations	567	417		150	567	
Ohio Grants & Contracts	150			150	150	
Subtotal State Support	5,232	4,932		300	5,232	
Federal Grants & Contracts	1,055			1,200	1,200	13.7%
Local Grants & Contracts						
Subtotal Government	6,287	4,932		1,500	6,432	2.3%
Student Fees						
Instructional, General and Tuition	3,235	3,476			3,476	7.4%
Other	302					-100.0%
Subtotal Student Fees	3,537	3,476			3,476	-1.7%
Other Resources						
Health System						
Auxiliary Sales & Services						
Departmental Sales & Services	1,452		1,285		1,285	-11.5%
Private Grants & Contracts	90			50	50	-44.4%
Endowment Income	80			55	55	-31.3%
Investment Income	75	25			25	-66.7%
Other	79	72			72	-8.9%
Subtotal Other	1,776	97	1,285	105	1,487	-16.3%
Total Resources	11,600	8,505	1,285	1,605	11,395	-1.8%
EXPENDITURES						
Instruction & General						
Instruction & Departmental Research	6,416	4,411	628	450	5,489	-14.4%
Academic Support	470	806	33	20	859	82.8%
Student Services	536	848		3	851	58.8%
Institutional Support	1,922	1,134	13	120	1,267	-34.1%
Plant, Operations & Maintenance	1,323	1,159		2	1,161	-12.2%
Subtotal Instruction & General	10,667	8,358	674	595	9,627	-9.7%
Separately Budgeted Research	229			220	220	-3.9%
Public Service	100		420	240	660	560.0%
Scholarships & Fellowships	525			550	550	4.8%
Auxiliaries						
Health System						
Total Expenditures	11,521	8,358	1,094	1,605	11,057	-4.0%

(1) Student Services increases are due primarily to a correction in the way the Regional Campus Service Charge is allocated based on the Columbus Campus costs built into the calculation.

DETAIL OF BUDGETED RESOURCES AND EXPENDITURES
OHIO AGRICULTURAL AND RESEARCH DEVELOPMENT CENTER BY FUND
(IN THOUSANDS)

	2001-02	2002-2003			Total Budget	Percent Change
	Revised Budget	General	Earnings	Restricted		
RESOURCES						
Government Support						
State Support						
State Share of Instruction						
Appropriations	36,407			36,407	36,407	
Ohio Grants & Contracts	350			350	350	
Subtotal State Support	36,757			36,757	36,757	
Federal Grants & Contracts	8,000			8,000	8,000	
Local Grants & Contracts	55			50	50	-9.1%
Subtotal Government	44,812			44,807	44,807	-0.0%
Student Fees						
Instructional, General and Tuition						
Other						
Subtotal Student Fees						
Other Resources						
Health System						
Auxiliary Sales & Services						
Departmental Sales & Services	1,150		1,370		1,370	19.1%
Private Grants & Contracts	4,000			4,000	4,000	
Endowment Income	200			200	200	
Investment Income						
Other						
Subtotal Other	5,350		1,370	4,200	5,570	4.1%
Total Resources	50,162		1,370	49,007	50,377	0.4%

EXPENDITURES

Instruction & General						
Instruction & Departmental Research	50			50	50	
Academic Support	4,150		1,370	3,000	4,370	5.3%
Student Services						
Institutional Support	1			10	10	900.0%
Plant, Operations & Maintenance	5,000			5,000	5,000	
Subtotal Instruction & General	9,201		1,370	8,060	9,430	2.5%
Separately Budgeted Research	40,721			40,677	40,677	-0.1%
Public Service	75			100	100	33.3%
Scholarships & Fellowships	165			170	170	3.0%
Auxiliaries						
Health System						
Total Expenditures	50,162		1,370	49,007	50,377	0.4%

**SUMMARY OF STATE SUPPORT
COLUMBUS CAMPUS
(IN THOUSANDS)**

	2001-02	2002-2003		Total Budget	Dollar Change	Percent Change
	Revised Budget	General Funds	Restricted			
CORE FUNDING						
Instructional Funding	305,389	305,389		305,389	0	0.0%
Mission-Based Core Funding:						
Success Challenge	9,224	9,224		9,224	0	0.0%
Research Challenge	8,070	8,070		8,070	0	0.0%
Priorities in Graduate Education	795		795	795	0	0.0%
Subtotal Core Funding	323,478	322,683	795	323,478	0	0.0%
APPROPRIATIONS						
OSU-Specific Line Items:						
Cooperative Extension	26,046		26,046	26,046	0	0.0%
Clinical Teaching	15,030		15,030	15,030	0	0.0%
Sea Grants	282		282	282	0	0.0%
Dental/Veterinary Medicine	1,937		1,937	1,937	0	0.0%
Supercomputer	4,544		4,544	4,544	0	0.0%
OARNET	3,300		3,300	3,300	0	0.0%
OSU Glenn Institute	345	345		345	0	0.0%
BioMEMS Program	230		230	230	0	0.0%
Subtotal OSU-Specific Line Items	51,714	345	51,369	51,714	0	0.0%
General Line Items						
Math/Science Teaching Improvement	363		363	363	0	0.0%
Urban Universities	227		227	227	0	0.0%
College Readiness Initiatives	41		41	41	0	0.0%
Library Book Depository	424	424		424	0	0.0%
Student Support Services	187	187		187	0	0.0%
Capital Component	1,160		1,160	1,160	0	0.0%
Medical Items:						
Family Practice	908		908	908	0	0.0%
Primary Care	378		378	378	0	0.0%
Geriatric Medicine	146		146	146	0	0.0%
Area Health Education Center	230		230	230	0	0.0%
Subtotal General Line Items	4,064	611	3,453	4,064	0	0.0%
Total Appropriations	55,778	956	54,822	55,778	0	0.0%
OHIO GRANTS & CONTRACTS	35,136	1,470	35,000	36,470	1,334	3.8%
TOTAL STATE SUPPORT	414,392	325,109	90,617	415,726	1,334	0.3%

**SUMMARY OF STATE SUPPORT
EXTENDED CAMPUSES
(IN THOUSANDS)**

	2001-02		2002-03		Dollar Change	Percent Change
	Total Budget	General Funds	Restricted	Total Budget		
<u>LIMA CAMPUS</u>						
State Share of Instruction	3,956	3,956		3,956	0	0.0%
State Appropriations						
Access Challenge	612	612		612	0	0.0%
Jobs Challenge	60	60		60	0	0.0%
Capital Component	178		178	178	0	0.0%
Subtotal Appropriations	850	672	178	850	0	0.0%
State Grants & Contracts	109	0	109	109	0	0.0%
Total Lima Campus	4,915	4,628	287	4,915	0	0.0%
<u>MANSFIELD CAMPUS</u>						
State Share of Instruction	4,165	4,165		4,165	0	0.0%
State Appropriations						
Access Challenge	669	669		669	0	0.0%
Jobs Challenge	57	57		57	0	0.0%
Capital Component	265		265	265	0	0.0%
Subtotal Appropriations	991	726	265	991	0	0.0%
State Grants & Contracts	238		263	263	25	10.5%
Total Mansfield Campus	5,394	4,891	528	5,419	25	0.5%
<u>MARION CAMPUS</u>						
State Share of Instruction	3,461	3,461		3,461	0	0.0%
State Appropriations						
Access Challenge	477	477		477	0	0.0%
Jobs Challenge	60	60		60	0	0.0%
Capital Component	7		7	7	0	0.0%
Subtotal Appropriations	544	537	7	544	0	0.0%
State Grants & Contracts	58		19	19	(39)	-67.2%
Total Marion Campus	4,063	3,998	26	4,024	(39)	-1.0%

**SUMMARY OF STATE SUPPORT
EXTENDED CAMPUSES
(IN THOUSANDS)**

	2001-02	2002-03		Total Budget	Dollar Change	Percent Change
	Total Budget	General Funds	Restricted			
<u>NEWARK CAMPUS</u>						
State Share of Instruction	5,142	5,142		5,142	0	0.0%
State Appropriations						
Access Challenge	740	740		740	0	0.0%
Jobs Challenge	42	42		42	0	0.0%
Capital Component	345		345	345	0	0.0%
Subtotal Appropriations	1,127	782	345	1,127	0	0.0%
State Grants & Contracts	20		20	20	0	0.0%
Total Newark Campus	6,289	5,924	365	6,289	0	0.0%
<u>AGRICULTURAL TECH INSTITUTE</u>						
State Share of Instruction	4,515	4,515		4,515	0	0.0%
State Appropriations						
Access Challenge	349	349		349	0	0.0%
Jobs Challenge	68	68		68	0	0.0%
Capital Component	150		150	150	0	0.0%
Subtotal Appropriations	567	417	150	567	0	0.0%
State Grants & Contracts	150		150	150	0	0.0%
Total ATI	5,232	4,932	300	5,232	0	0.0%
<u>OARDC</u>						
Appropriations	36,407		36,407	36,407	0	0.0%
State Grants & Contracts	350		350	350	0	0.0%
Total OARDC	36,757	0	36,757	36,757	0	0.0%
<u>TOTAL EXTENDED CAMPUSES</u>						
State Share of Instruction	21,239	21,239	0	21,239	0	0.0%
Appropriations	40,486	3,134	37,352	40,486	0	0.0%
State Grants & Contracts	925	0	911	911	(14)	-1.5%
Total Extended Campuses	62,650	24,373	38,263	62,636	(14)	-0.0%

SUMMARY OF STUDENT FEE INCOME
COLUMBUS CAMPUS
 (IN THOUSANDS)

INSTRUCTIONAL FEES

Resident Fees
 General Fees
 Non-Resident Surcharge

Subtotal Instructional Fees

OTHER FEES

Application Fees
 Acceptance Fees
 Instructional Technology Fees
 Study Abroad
 Continuing Education
 Flight Instruction
 Medical Instrument Fees
 COTA Fees
 Other

Subtotal Other Fees

TOTAL STUDENT FEES INCOME

	FY 2002 BUDGET	FY 2003 BUDGET	DOLLAR CHANGE	PERCENT CHANGE
Resident Fees	254,473	287,887	33,414	13.1%
General Fees	17,007	17,687	680	4.0%
Non-Resident Surcharge	91,670	101,859	10,189	11.1%
Subtotal Instructional Fees	363,150	407,433	44,283	12.2%
Application Fees	1,500	1,500	0	0.0%
Acceptance Fees	750	750	0	0.0%
Instructional Technology Fees	2,390	2,690	300	12.6%
Study Abroad	2,735	3,000	265	9.7%
Continuing Education	250	250	0	0.0%
Flight Instruction	675	710	35	5.2%
Medical Instrument Fees	1,300	1,400	100	7.7%
COTA Fees	1,400	1,400	0	0.0%
Other	1,090	1,090	0	0.0%
Subtotal Other Fees	12,090	12,790	700	5.8%
TOTAL STUDENT FEES INCOME	375,240	420,223	44,983	12.0%

**2002-2003 STUDENT FEE SCHEDULE
FEES PER QUARTER
COLUMBUS CAMPUS**

Undergraduate *
Continuing

Credit Hours	Instructional Fees	General Fees	Resident Total	Non-Resident Tuition	Non-Resident Total
0	134	8	142	131	273
1	268	15	283	262	545
2	335	23	358	524	882
3	403	30	433	785	1,218
4	537	40	577	1,047	1,624
5	671	50	721	1,309	2,030
6	805	60	865	1,571	2,436
7	939	70	1,009	1,832	2,841
8	1,073	80	1,153	2,094	3,247
9	1,208	90	1,298	2,356	3,654
10	1,342	100	1,442	2,618	4,060
11	1,476	110	1,586	2,879	4,465
12+	1,610	120	1,730	3,141	4,871

Undergraduate *
New Students

Credit Hours	Instructional Fees	General Fees	Resident Total	Non-Resident Tuition	Non-Resident Total
0	148	8	156	131	287
1	295	15	310	262	572
2	368	23	391	524	915
3	442	30	472	785	1,257
4	589	40	629	1,047	1,676
5	737	50	787	1,309	2,096
6	884	60	944	1,571	2,515
7	1,031	70	1,101	1,832	2,933
8	1,179	80	1,259	2,094	3,353
9	1,326	90	1,416	2,356	3,772
10	1,473	100	1,573	2,618	4,191
11	1,621	110	1,731	2,879	4,610
12+	1,768	120	1,888	3,141	5,029

* Undergraduate Fees Effective Summer Quarter 2002.

**2002-2003 STUDENT FEE SCHEDULE
FEES PER QUARTER
COLUMBUS CAMPUS**

Graduate

Credit Hours	Instructional Fees	General Fees	Resident Total	Non-Resident Tuition	Non-Resident Total
0	131	8	139	177	316
1	261	15	276	353	629
2	417	24	441	705	1,146
3	625	36	661	1,058	1,719
4	834	48	882	1,410	2,292
5	1,042	60	1,102	1,763	2,865
6	1,250	72	1,322	2,115	3,437
7	1,459	84	1,543	2,468	4,011
8	1,667	96	1,763	2,820	4,583
9	1,876	108	1,984	3,173	5,157
10+	2,084	120	2,204	3,525	5,729

MLHR

Credit Hours	Instructional Fees	General Fees	Resident Total	Non-Resident Tuition	Non-Resident Total
0	142	8	150	177	327
1	284	15	299	353	652
2	454	24	478	705	1,183
3	682	36	718	1,058	1,776
4	909	48	957	1,410	2,367
5	1,136	60	1,196	1,763	2,959
6	1,363	72	1,435	2,115	3,550
7	1,590	84	1,674	2,468	4,142
8	1,818	96	1,914	2,820	4,734
9	2,045	108	2,153	3,173	5,326
10+	2,272	120	2,392	3,525	5,917

**2002-2003 STUDENT FEE SCHEDULE
FEES PER QUARTER
COLUMBUS CAMPUS**

MBA

Credit Hours	Instructional Fees	General Fees	Resident Total	Non-Resident Tuition	Non-Resident Total
0	261	8	269	177	446
1	522	15	537	353	890
2	835	24	859	705	1,564
3	1,253	36	1,289	1,058	2,347
4	1,671	48	1,719	1,410	3,129
5	2,089	60	2,149	1,763	3,912
6	2,506	72	2,578	2,115	4,693
7	2,924	84	3,008	2,468	5,476
8	3,342	96	3,438	2,820	6,258
9	3,759	108	3,867	3,173	7,040
10+	4,177	120	4,297	3,525	7,822

EMBA

Credit Hours	Instructional Fees	General Fees	Resident Total	Non-Resident Tuition	Non-Resident Total
0	604	8	612	177	789
1	1,207	15	1,222	353	1,575
2	1,931	24	1,955	705	2,660
3	2,897	36	2,933	1,058	3,991
4	3,863	48	3,911	1,410	5,321
5	4,829	60	4,889	1,763	6,652
6	5,794	72	5,866	2,115	7,981
7	6,760	84	6,844	2,468	9,312
8	7,726	96	7,822	2,820	10,642
9	8,691	108	8,799	3,173	11,972
10+	9,657	120	9,777	3,525	13,302

**2002-2003 STUDENT FEE SCHEDULE
FEES PER QUARTER
COLUMBUS CAMPUS**

Master of Accounting

Credit Hours	Instructional Fees	General Fees	Resident Total	Non-Resident Tuition	Non-Resident Total
0	338	8	346	177	523
1	676	15	691	353	1,044
2	1,082	24	1,106	705	1,811
3	1,623	36	1,659	1,058	2,717
4	2,164	48	2,212	1,410	3,622
5	2,705	60	2,765	1,763	4,528
6	3,246	72	3,318	2,115	5,433
7	3,787	84	3,871	2,468	6,339
8	4,328	96	4,424	2,820	7,244
9	4,869	108	4,977	3,173	8,150
10+	5,410	120	5,530	3,525	9,055

Health Administration

Credit Hours	Instructional Fees	General Fees	Resident Total	Non-Resident Tuition	Non-Resident Total
0	162	8	170	177	347
1	323	15	338	353	691
2	516	24	540	705	1,245
3	774	36	810	1,058	1,868
4	1,032	48	1,080	1,410	2,490
5	1,290	60	1,350	1,763	3,113
6	1,548	72	1,620	2,115	3,735
7	1,806	84	1,890	2,468	4,358
8	2,064	96	2,160	2,820	4,980
9	2,322	108	2,430	3,173	5,603
10+	2,580	120	2,700	3,525	6,225

**2002-2003 STUDENT FEE SCHEDULE
FEES PER QUARTER
COLUMBUS CAMPUS**

Public Health MPH

Credit Hours	Instructional Fees	General Fees	Resident Total	Non-Resident Tuition	Non-Resident Total
0	137	8	145	177	322
1	273	15	288	353	641
2	437	24	461	705	1,166
3	655	36	691	1,058	1,749
4	873	48	921	1,410	2,331
5	1,092	60	1,152	1,763	2,915
6	1,310	72	1,382	2,115	3,497
7	1,528	84	1,612	2,468	4,080
8	1,746	96	1,842	2,820	4,662
9	1,965	108	2,073	3,173	5,246
10+	2,183	120	2,303	3,525	5,828

Public Health PEP

Credit Hours	Instructional Fees	General Fees	Resident Total	Non-Resident Tuition	Non-Resident Total
0	139	8	147	177	324
1	278	15	293	353	646
2	445	24	469	705	1,174
3	667	36	703	1,058	1,761
4	889	48	937	1,410	2,347
5	1,112	60	1,172	1,763	2,935
6	1,334	72	1,406	2,115	3,521
7	1,556	84	1,640	2,468	4,108
8	1,778	96	1,874	2,820	4,694
9	2,001	108	2,109	3,173	5,282
10+	2,223	120	2,343	3,525	5,868

**2002-2003 STUDENT FEE SCHEDULE
FEES PER QUARTER
COLUMBUS CAMPUS**

Master of Physical Therapy

Credit Hours	Instructional Fees	General Fees	Resident Total	Non-Resident Tuition	Non-Resident Total
0	143	8	151	177	328
1	285	15	300	353	653
2	455	24	479	705	1,184
3	683	36	719	1,058	1,777
4	911	48	959	1,410	2,369
5	1,139	60	1,199	1,763	2,962
6	1,366	72	1,438	2,115	3,553
7	1,594	84	1,678	2,468	4,146
8	1,822	96	1,918	2,820	4,738
9	2,049	108	2,157	3,173	5,330
10+	2,277	120	2,397	3,525	5,922

Pharmacy

Credit Hours	Instructional Fees	General Fees	Resident Total	Non-Resident Tuition	Non-Resident Total
0	172	8	180	235	415
1	344	15	359	469	828
2	550	24	574	750	1,324
3	825	36	861	1,125	1,986
4	1,100	48	1,148	1,500	2,648
5	1,375	60	1,435	1,875	3,310
6	1,650	72	1,722	2,250	3,972
7	1,925	84	2,009	2,625	4,634
8	2,200	96	2,296	3,000	5,296
9	2,475	108	2,583	3,375	5,958
10+	2,750	120	2,870	3,750	6,620

**2002-2003 STUDENT FEE SCHEDULE
FEES PER QUARTER
COLUMBUS CAMPUS**

Medicine Fees*

Credit Hours	Instructional Fees	General Fees	Resident Total	Non-Resident Tuition	Non-Resident Total
0	356	8	364	483	847
1	711	15	726	965	1,691
2	1,137	24	1,161	1,545	2,706
3	1,705	36	1,741	2,317	4,058
4	2,274	48	2,322	3,089	5,411
5	2,842	60	2,902	3,862	6,764
6	3,410	72	3,482	4,634	8,116
7	3,979	84	4,063	5,406	9,469
8	4,547	96	4,643	6,178	10,821
9	5,116	108	5,224	6,951	12,175
10+	5,684	120	5,804	7,723	13,527

Optometry Fees

Credit Hours	Instructional Fees	General Fees	Resident Total	Non-Resident Tuition	Non-Resident Total
0	228	8	236	453	689
1	455	15	470	905	1,375
2	728	24	752	1,448	2,200
3	1,093	36	1,129	2,172	3,301
4	1,457	48	1,505	2,896	4,401
5	1,821	60	1,881	3,620	5,501
6	2,185	72	2,257	4,344	6,601
7	2,549	84	2,633	5,068	7,701
8	2,914	96	3,010	5,792	8,802
9	3,278	108	3,386	6,516	9,902
10+	3,642	120	3,762	7,240	11,002

* Medicine will offer tuition credits for students in levels 1, 2 & 3 that will effectively lower their fees in FY 2003.

**2002-2003 STUDENT FEE SCHEDULE
FEES PER QUARTER
COLUMBUS CAMPUS**

Dentistry Fees

Credit Hours	Instructional Fees	General Fees	Resident Total	Non-Resident Tuition	Non-Resident Total
0	292	8	300	453	753
1	583	15	598	905	1,503
2	933	24	957	1,448	2,405
3	1,399	36	1,435	2,172	3,607
4	1,865	48	1,913	2,896	4,809
5	2,332	60	2,392	3,620	6,012
6	2,798	72	2,870	4,344	7,214
7	3,264	84	3,348	5,068	8,416
8	3,730	96	3,826	5,792	9,618
9	4,197	108	4,305	6,516	10,821
10+	4,663	120	4,783	7,240	12,023

Vet Medicine Fees

Credit Hours	Instructional Fees	General Fees	Resident Total	Non-Resident Tuition	Non-Resident Total
0	268	8	276	468	744
1	535	15	550	935	1,485
2	855	24	879	1,497	2,376
3	1,283	36	1,319	2,245	3,564
4	1,710	48	1,758	2,993	4,751
5	2,138	60	2,198	3,742	5,940
6	2,566	72	2,638	4,490	7,128
7	2,993	84	3,077	5,238	8,315
8	3,421	96	3,517	5,986	9,503
9	3,848	108	3,956	6,735	10,691
10+	4,276	120	4,396	7,483	11,879

**2002-2003 STUDENT FEE SCHEDULE
FEES PER SEMESTER
COLUMBUS CAMPUS**

Law (Semester)

Credit Hours	Instructional Fees	General Fees	Resident Total	Non-Resident Tuition	Non-Resident Total
0	360	12	372	357	729
1	720	23	743	714	1,457
2	1,152	36	1,188	1,142	2,330
3	1,728	54	1,782	1,713	3,495
4	2,304	72	2,376	2,284	4,660
5	2,880	90	2,970	2,855	5,825
6	3,456	108	3,564	3,426	6,990
7	4,032	126	4,158	3,997	8,155
8	4,608	144	4,752	4,568	9,320
9	5,184	162	5,346	5,139	10,485
10+	5,760	180	5,940	5,710	11,650

2002-2003 STUDENT FEE SCHEDULE
FEES PER QUARTER
LIMA, MANSFIELD, MARION AND NEWARK CAMPUSES

Undergraduate
Lower Division

Credit Hours	Instructional Fees	General Fees	* BOR - AC Credit	Resident Total	Non-Resident Tuition	Non-Resident Total
0	121	6	(17)	110	131	241
1	241	11	(33)	219	262	481
2	301	14	(42)	273	524	797
3	361	17	(50)	328	785	1,113
4	481	22	(67)	436	1,047	1,483
5	601	28	(83)	546	1,309	1,855
6	722	33	(100)	655	1,571	2,226
7	842	39	(117)	764	1,832	2,596
8	962	44	(133)	873	2,094	2,967
9	1,082	50	(150)	982	2,356	3,338
10	1,203	55	(167)	1,091	2,618	3,709
11	1,323	61	(183)	1,201	2,879	4,080
12+	1,443	66	(200)	1,309	3,141	4,450

Undergraduate
Upper Division

Credit Hours	Instructional Fees	General Fees	* BOR - AC Credit	Resident Total	Non-Resident Tuition	Non-Resident Total
0	121	6	(5)	122	131	253
1	241	11	(9)	243	262	505
2	301	14	(11)	304	524	828
3	361	17	(14)	364	785	1,149
4	481	22	(18)	485	1,047	1,532
5	601	28	(23)	606	1,309	1,915
6	722	33	(27)	728	1,571	2,299
7	842	39	(32)	849	1,832	2,681
8	962	44	(36)	970	2,094	3,064
9	1,082	50	(41)	1,091	2,356	3,447
10	1,203	55	(45)	1,213	2,618	3,831
11	1,323	61	(50)	1,334	2,879	4,213
12+	1,443	66	(54)	1,455	3,141	4,596

* The Board of Regents Access Challenge Credit represents additional subsidy to ATI and the Regional Campuses to make tuition more affordable.

2002-2003 STUDENT FEE SCHEDULE
FEE PER QUARTER
LIMA, MANSFIELD, MARION AND NEWARK CAMPUSES

Graduate

Credit Hours	Instructional Fees	General Fees	BOR - AC Credit	Resident Total	Non-Resident Tuition	Non-Resident Total
0	131	4	0	135	177	312
1	261	8	0	269	353	622
2	417	13	0	430	705	1,135
3	625	20	0	645	1,058	1,703
4	834	26	0	860	1,410	2,270
5	1,042	33	0	1,075	1,763	2,838
6	1,250	40	0	1,290	2,115	3,405
7	1,459	46	0	1,505	2,468	3,973
8	1,667	53	0	1,720	2,820	4,540
9	1,876	59	0	1,935	3,173	5,108
10+	2,084	66	0	2,150	3,525	5,675

AGRICULTURAL TECHNICAL INSTITUTE

Undergraduate

Credit Hours	Instructional Fees	General Fees	BOR - AC Credit	Resident Total	Non-Resident Tuition	Non-Resident Total
0	120	6	(16)	110	131	241
1	240	11	(31)	220	262	482
2	300	14	(38)	276	524	800
3	360	17	(46)	331	785	1,116
4	479	22	(61)	440	1,047	1,487
5	599	28	(76)	551	1,309	1,860
6	719	33	(92)	660	1,571	2,231
7	839	39	(107)	771	1,832	2,603
8	959	44	(122)	881	2,094	2,975
9	1,079	50	(137)	992	2,356	3,348
10	1,198	55	(153)	1,100	2,618	3,718
11	1,318	61	(168)	1,211	2,879	4,090
12+	1,438	66	(183)	1,321	3,141	4,462

* The Board of Regents Access Challenge Credit represents additional subsidy to ATI and the Regional Campuses to make tuition more affordable.

ANNUAL FEE HISTORY

COLUMBUS CAMPUS RESIDENT FEES

		FY 1993	FY 1999	FY 2000	FY 2001	FY 2002	FY 2003	10 Year Average Increase
Undergraduate:	(1)							
Continuing Students	(2)	2,799	3,879	4,110	4,356	4,761	5,190	6.4%
New Students	(2)	2,799	3,879	4,110	4,356	4,761	5,664	7.3%
Graduate Programs:	(1)							
Graduate		3,966	5,445	5,730	6,021	6,306	6,612	5.2%
MLHR		3,966	5,445	5,730	6,021	6,843	7,176	6.1%
MBA	(4)	3,966	5,898	6,744	9,024	11,334	12,891	12.5%
EMBA	(3)	NA	NA	NA	26,076	27,402	29,331	NA
Master of Accounting	(3)	NA	NA	NA	15,036	15,810	16,590	NA
Health Administration	(4)	3,966	5,445	5,730	6,021	6,306	8,100	7.4%
Public Health MPH	(4)	3,966	5,445	5,730	6,021	6,306	6,909	5.7%
Public Health PEP	(4)	3,966	5,445	5,730	6,021	6,306	7,029	5.9%
Master of Physical Therapy	(3)	NA	NA	NA	NA	6,561	7,191	NA
Professional:	(1)							
Pharmacy		4,697	6,429	6,765	7,107	7,716	8,610	6.2%
Dentistry		6,321	9,813	10,746	11,757	12,840	14,349	8.5%
Optometry		6,321	8,955	9,420	9,897	10,374	11,286	6.0%
Veterinary Medicine		6,321	9,306	10,191	11,049	12,012	13,188	7.6%
Law		4,584	7,692	8,424	9,984	10,826	11,880	10.0%
Medicine	(5)	7,710	11,637	12,744	13,821	15,168	17,412	8.5%

- (1) Full time fees for undergraduates are 12+ hours & for Graduates and Professional programs are 10+.
- (2) For the first time, undergraduate fees are broken out between continuing and new students.
- (3) These are new degree granting programs.
- (4) These are graduate programs that once charged the graduate fee but now have differential fees.
- (5) Medicine will offer tuition credits to students in levels 1, 2 & 3 bringing their effective instructional fee increases to 11.8% for levels 1 & 2, and 8.2% for level 3.

SUMMARY OF TYPICAL STUDENT FEES COLUMBUS CAMPUS

		UNDERGRADUATE FEES CONTINUING STUDENTS				UNDERGRADUATE FEES NEW STUDENTS			
		2000-02 Fees	2002-03 Fees	Dollar Change	Percent Change	2000-02 Fees	2002-03 Fees	Dollar Change	Percent Change
RESIDENT FEES									
Instructional & General	(1)	4,761	5,190	429	9.0%	4,761	5,664	903	19.0%
Room & Board	(2)	5,937	6,219	282	4.7%	5,937	6,219	282	4.7%
Text Books/Supplies	(3)	932	979	47	5.0%	932	979	47	5.0%
Subtotal		11,630	12,388	758	6.5%	11,630	12,862	1,232	10.6%
Health Insurance	(4)	753	813	60	8.0%	753	813	60	8.0%
Parking & Bus Pass	(5)	149	163	15	10.1%	149	163	15	10.1%
COTA Pass		27	27	0	0.0%	27	27	0	0.0%
Football Tickets	(6)	100	105	5	5.0%	100	105	5	5.0%
Basketball Tickets	(6)	64	64	0	0.0%	64	64	0	0.0%
Total		12,723	13,560	838	6.6%	12,723	14,034	1,312	10.3%
NON-RESIDENT FEES									
Instructional & General	(1)	4,761	5,190	429	9.0%	4,761	5,664	903	19.0%
Non-Resident Tuition		8,766	9,423	657	7.5%	8,766	9,423	657	7.5%
Room & Board	(2)	5,937	6,219	282	4.7%	5,937	6,219	282	4.7%
Text Books/Supplies	(3)	932	979	47	5.0%	932	979	47	5.0%
Subtotal		20,396	21,811	1,415	6.9%	20,396	22,285	1,889	9.3%
Health Insurance	(4)	753	813	60	8.0%	753	813	60	8.0%
Parking & Bus Pass	(5)	149	163	15	10.1%	149	163	15	10.1%
COTA Pass		27	27	0	0.0%	27	27	0	0.0%
Football Tickets	(6)	100	105	5	5.0%	100	105	5	5.0%
Basketball Tickets	(6)	64	64	0	0.0%	64	64	0	0.0%
Total		21,489	22,983	1,495	7.0%	21,489	23,457	1,969	9.2%

- (1) Will increase 9.0% for continuing students and 19% for new students effective Summer 2002.
- (2) Undergraduate - Weighted average room rate +10 meal plan.
- (3) Estimated costs and inflationary increase per OSU Bookstore.
- (4) Student insurance is based on the single student medical only rate.
- (5) Using main campus rate.
- (6) Five football and eight basketball games.

DETAIL OF SELECTED RATES

OTHER STUDENT FEES

FY 2003

Description	Timing	Rate	Percent Change
Housing, Food Service and Event Centers			
Undergraduate (Weighted average room rates + 10 meals/week)	Quarter	2,073.00	4.7%
Graduate (Single + Phone)	Month	364.00	4.3%
Married Student Housing (2 bedroom apartment)	Month	600.00	6.0%
Board Only (10 meals/week)	Quarter	835.00	4.4%
Parking & Transportation			
Parking, 4-Wheel Vehicle (Main Campus)	Annual	163.80	10.3%
Parking, 4-Wheel Vehicle (West Campus)	Annual	41.40	9.5%
COTA Bus Pass	Quarter	9.00	0.0%
Recreational Fees			
Football Tickets	Per Game	21.00	5.0%
Basketball Tickets	Per Game	8.00 - 12.00	0.0%
Golf Course Membership	Annual	550.00	0.0%
Golf Course Greens Fees	Per Round	14.00 - 18.00	0.0%
Larkins Locker Fee	Quarter	13.00	4.0%
Student Health Insurance			
Student	Quarter	287.00	14.3%
Student & Spouse	Quarter	735.00	14.5%
Student & Children	Quarter	740.00	14.4%
Student, Spouse & Children	Quarter	992.00	14.4%
Law Students	Semester	431.00 - 1,488.00	14.4%
Early Arriving Students	Month	96.00 - 331.00	14.5%
Clinic Fees			
Dental Hygiene EFDA Fee	Quarter	117.00	9.3%
Nursing Clinical Fee (Undergraduate)	Quarter	150.00	New
Nursing Clinical Fee (Graduate)	Annual	600.00 - 750.00	New

DETAIL OF SELECTED RATES
OTHER STUDENT FEES
 FY 2002

Description	Timing	Rate	Percent Change
Learning Technology Fees			
College of Arts (Undergraduate & Graduate)	Quarter	43.00	0.0%
College of Business (Undergraduate)	Quarter	85.00	0.0%
College of Business (Graduate)	Quarter	120.00	0.0%
College of Engineering (Undergraduate)	Quarter	110.00	0.0%
College of Engineering (Graduate)	Quarter	120.00	0.0%
College of Nursing (Undergraduate & Graduate)	Quarter	43.00	0.0%
Department of CIS in Math & Phys Sci (Undergraduate)	Quarter	73.00	0.0%
Department of CIS in Math & Phys Sci (Graduate)	Quarter	80.00	0.0%
School of Public Policy & Management (Graduate)	Quarter	120.00	0.0%
Equipment Fees			
Optometry Equipment	One Time	340.00	0.0%
Dental Clinical Education Support Fee	Quarter	902.00	8.9%
Dental Hygiene Clinical Education Support Fee	Quarter	347.00	9.1%
Application Fees			
International (All Students)	One Time	40.00	0.0%
Domestic (All Students)	One Time	30.00	0.0%
Acceptance Fees			
Undergraduate	One Time	70.00	0.0%
Graduate		N/A	N/A
Professional	One Time	25.00	0.0%
Penalties (all students)			
Late Registration - After 1st day of classes	Quarter	100.00	0.0%
Late Registration - After 2nd Friday of classes	Quarter	500.00	0.0%
Late Fee Payment - After 1st day of classes	Quarter	100.00	0.0%
Late Fee Payment - After 2nd Friday of classes	Quarter	300.00	0.0%

**DETAIL OF SELECTED RATES
FACULTY, STAFF & DEPARTMENTAL FEES
FY 2002**

Description	Timing	Rate	Percent Change
Health Insurance *			
Prime Care Plan			
Individual	Month	41.15	18.8%
Family	Month	128.59	18.8%
OSUHP Plan			
Individual	Month	166.06	4.1%
Family	Month	518.96	4.1%
Traditional Plan			
Individual	Month	166.06	4.1%
Family	Month	518.96	4.1%
Buckeye Plan			
Individual	Month	16.63	18.8%
Family	Month	51.96	18.8%
Parking & Transportation			
Parking, 4-Wheel Vehicle A Decal (Main Campus)	Annual	474.00	9.7%
Parking, 4-Wheel Vehicle B Decal (Main Campus)	Annual	247.20	9.9%
Recreational Fees			
Football Tickets	Per Game	36.00	2.9%
Basketball Tickets	Per Game	15.00 - 20.50	0.0%
Golf Course Membership	Annual	1,600.00	0.0%
Golf Course Greens Fees	Per Round	23.00 - 30.00	0.0%
Departmental Rates			
Basic Telephone Service	Month	20.00	-3.1%
University Health System	Various	Various	15.0%

(*) Reflects transition to common risk pool.

**SUMMARY OF RESIDENT STUDENT FEES
BIG TEN PUBLIC INSTITUTIONS
FOR FY 2002 AND FY 2003**

	UNDERGRADUATE FEES CONTINUING STUDENTS				UNDERGRADUATE FEES NEW STUDENTS			
	FY 2002	FY 2003	1 Year	5-Year	FY 2002	FY 2003	1 Year	5-Year
	Fees	Fees	% Change	Avg % Change	Fees	Fees	% Change	Avg % Change
Penn State	7,574	8,634	14.0%	9.4%	7,574	8,634	14.0%	9.4%
Michigan	7,375	7,803	5.8%	5.0%	7,375	7,803	5.8%	5.0%
Michigan State	5,912	6,415	8.5%	5.5%	5,912	6,415	8.5%	5.5%
Minnesota	5,536	6,280	13.4%	8.1%	5,536	6,280	13.4%	8.1%
Illinois	5,254	5,736	9.2%	6.4%	5,754	6,736	17.1%	11.0%
Indiana	4,734	5,315	12.3%	9.0%	4,734	5,315	12.3%	9.0%
Ohio State	4,761	5,189	9.0%	6.4%	4,761	5,663	18.9%	8.8%
Purdue	4,164	4,580	10.0%	7.3%	4,164	5,580	34.0%	11.3%
Wisconsin*	4,086	4,454	9.0%	7.5%	4,086	4,454	9.0%	7.5%
Iowa	3,521	4,191	19.0%	10.4%	3,521	4,191	19.0%	10.4%
Average	5,292	5,860	11.0%	7.3%	5,342	6,107	15.2%	8.5%

Source: FY 2002 AAU Data Exchange -- Tuition and Fees Survey
FY 2003 Contact with Big Ten Schools

* Note: Numbers from this university are based on best available information.

SUMMARY OF RESIDENT STUDENT FEES

BIG TEN PUBLIC INSTITUTIONS

FISCAL YEAR 2003

UNDERGRADUATE FEES -- CONTINUING	UNDERGRADUATE FEES -- NEW
---	----------------------------------

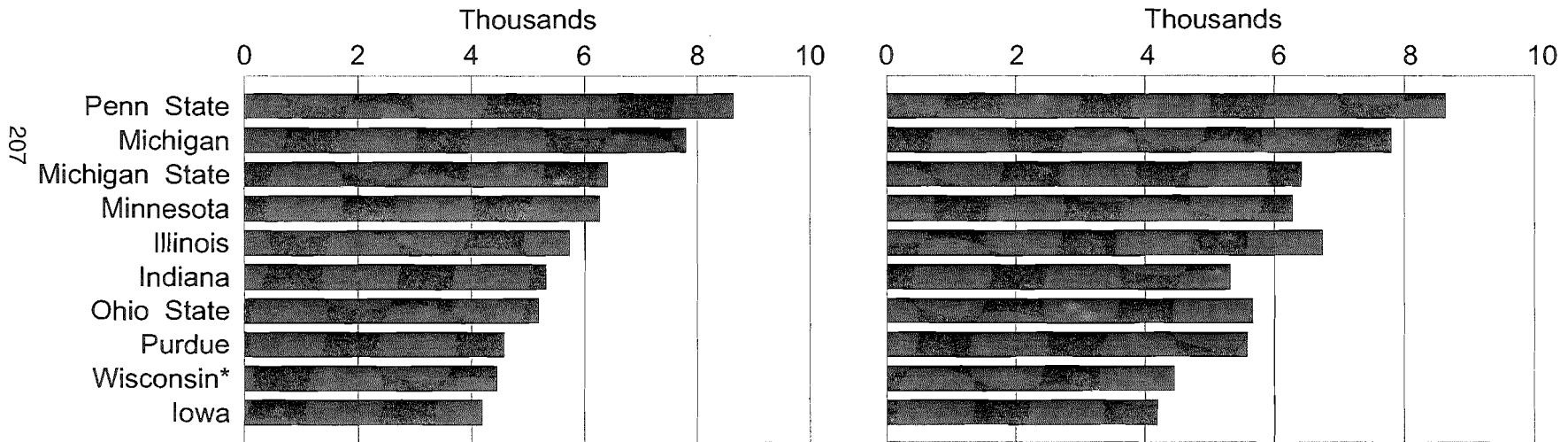

Source: Contact with Big Ten schools

* Note: Numbers from this university are based on best available information.

SUMMARY OF AUXILIARY OPERATIONS
FISCAL YEAR 2003
 IN THOUSANDS

208

	Resources			Expenditures & Transfers				Net Income	
	Auxiliary	General Funds	Restricted	Total Budget	Expends	Debt Service	Other Transfers		Total Budget
COLUMBUS CAMPUS									
Housing, Food Services and Event Centers (1)	74,678	1,888		76,566	61,826	8,167	6,146	76,139	427
Intercollegiate Athletics Schottenstein Center	71,185		7,850	79,035	59,299	16,127	3,550	78,976	59
Bookstores (2)	16,856			16,856	14,012	2,830		16,842	14
Transportation & Parking Svs (3)	2,290			2,290	2,241			2,241	49
University Airport (3)	17,123			17,123	14,409	3,093	502	18,004	(881)
Real Estate & Prop Mgt (3)	5,317			5,317	5,094	209	40	5,343	(26)
	668			668	784			784	(116)
Subtotal Columbus	188,117	1,888	7,850	197,855	157,665	30,426	10,238	198,329	(474)
LIMA CAMPUS									
Parking Facility	2			2	2			2	0
MANSFIELD CAMPUS									
Parking Facility	45			45	45			45	0
NEWARK CAMPUS									
Parking Facility	53			53	51			51	2
GRAND TOTAL	188,217	1,888	7,850	197,955	157,763	30,426	10,238	198,427	(472)

- (1) Includes Student Housing & Food Service, The Fawcett Center, Student Unions, ATI Dorm, Newark Housing and the Blackwell.
- (2) Consists primarily of the Medical Bookstore. The Main Bookstore and Regional Bookstores have been privatized.
- (3) Net losses will be offset by carry over cash balances.

HOUSING, FOOD SERVICES AND EVENT CENTERS

(IN THOUSANDS)

RESOURCES

		FY 2002 BUDGET	FY 2003 BUDGET	DOLLAR CHANGE	PERCENT CHANGE
Food Service		17,769	16,936	(833)	-4.7%
Housing		38,136	39,084	948	2.5%
Fawcett Center	(1)	4,384	2,861	(1,523)	-34.7%
ATI Residence Hall		1,311	1,763	452	34.5%
Newark Housing	(2)	0	517	517	
Ohio Union	(3)	1,482	1,195	(287)	-19.4%
Blackwell	(2)	0	6,546	6,546	
Other	(4)	5,140	5,776	636	12.4%
General Funds Support	(5)	1,828	1,888	60	3.3%
Subtotal Resources		70,050	76,566	6,516	9.3%

EXPENDITURES & TRANSFERS

Personnel		22,935	23,962	1,027	4.5%
Benefits		5,688	6,597	909	16.0%
Supplies & Services		24,686	26,191	1,505	6.1%
Equipment		1,356	1,633	277	20.4%
University Overhead		3,521	3,443	(78)	-2.2%
Debt Service		7,899	8,167	268	3.4%
Other Transfers	(6)	3,536	6,146	2,610	73.8%
Subtotal Expenditures & Transfers		69,621	76,139	6,518	9.4%

NET INCOME

	429	427	(2)	-0.5%
--	-----	-----	-----	-------

- (1) Budget has decreased due to the loss of hotel business.
- (2) New operation beginning FY 2003.
- (3) FY 2002 budgets restated to correct for double counting of the Unions General Fund Support.
- (4) Includes Success, Center, Buck ID, Summer Conferences, Oxley's and Drake.
- (5) FY 2002 budget restated to include additional support of the ID Center and the Living Learning Center.
- (6) FY 2002 budget was restated to remove double counting of Student Unions support. The large increase in FY 2003 is due to an increase in the Capital Reserves.

INTERCOLLEGIATE ATHLETICS

(IN THOUSANDS)

		FY 2002 BUDGET	FY 2003 BUDGET	DOLLAR CHANGE	PERCENT CHANGE
RESOURCES					
Auxiliary					
Football		21,010	26,580	5,570	26.5%
Stadium Revenue	(1)	14,610	15,010	400	2.7%
Men's Basketball		10,698	11,628	930	8.7%
Other Sports		1,223	1,260	37	3.0%
Golf Course		2,947	2,947	0	0.0%
Other		10,350	13,760	3,410	32.9%
Subtotal Auxiliary		60,838	71,185	10,347	17.0%
Restricted					
Fund Raising		7,800	7,850	50	0.6%
Total Resources		68,638	79,035	10,397	15.1%
EXPENDITURES & TRANSFERS					
Auxiliary					
Personnel		17,819	19,184	1,365	7.7%
Benefits		3,930	4,618	688	17.5%
Supplies & Services		18,102	21,014	2,912	16.1%
Equipment		444	1,080	636	143.2%
Schottenstein Rent		1,511	1,572	61	4.0%
University Overhead	(2)	2,622	3,216	594	22.7%
Athletics Grants-In-Aid	(3)	0	765	765	NA
Debt Service	(4)	14,400	16,127	1,727	12.0%
Other Transfers	(5)	1,781	3,550	1,769	99.3%
Subtotal Auxiliary		60,609	71,126	10,517	17.4%
Restricted					
Athletics Grants-In-Aid	(3)	7,609	7,850	241	3.2%
Debt Service		191	0	(191)	-100.0%
Subtotal Restricted		7,800	7,850	50	0.6%
Total Expenditures & Transfers		68,409	78,976	10,567	15.4%
NET INCOME		229	59	(170)	

(1) Consists of ticket surcharge, club seats, suite rental and scoreboard revenue. FY 2002 was restated to include this budget.

(2) Increase is partly due to a 17% increase in resources and partly due to under budgeting for FY 2002.

(3) Athletics Grants-In-Aid were fully funded by restricted funds in FY 2002 but must be supplemented by Auxiliary funds in FY 2003.

(4) FY 2002 budget was restated to include Stadium debt service.

(5) Large increase due to setting up a \$2.5 million operating reserve to offset future projected cash flow problems.

THE OHIO STATE UNIVERSITY HEALTH SYSTEM *

(IN THOUSANDS)

		FY 2002 BUDGET	FY 2003 BUDGET	DOLLAR CHANGE	PERCENT CHANGE
RESOURCES					
Auxiliary					
Inpatient Revenue (Net)		422,076	520,895	98,819	23.4%
Outpatient Revenue (Net)		205,479	264,839	59,360	28.9%
Other	(1)	44,848	42,783	(2,065)	-4.6%
Subtotal Auxiliary		672,403	828,517	156,114	23.2%
Restricted					
State Appropriation	(2)	9,842	6,100	(3,742)	-38.0%
Other		3,400	3,400	0	
Subtotal Restricted		13,242	9,500	(3,742)	-28.3%
Total Resources		685,645	838,017	152,372	22.2%
EXPENDITURES & TRANSFERS					
Auxiliary					
Patient Services	(1)	417,098	535,916	118,818	28.5%
Student Education		15,354	18,582	3,228	21.0%
Research		2,607	2,477	(130)	-5.0%
Administration		168,408	188,738	20,330	12.1%
Plant, Operation & Maintenance	(3)	23,986	32,926	8,940	37.3%
Other		0	0	0	
Transfers To Plant (Net)		39,539	43,487	3,948	10.0%
Subtotal Auxiliary		666,992	822,126	155,134	23.3%
Restricted		13,240	9,500	(3,740)	-28.2%
Total Expenditures & Transfers		680,232	831,626	151,394	22.3%
NET INCOME		5,413	6,391	978	18.1%

* Includes University Hospitals, James Cancer Hospital & Solove Research Institute, University Hospital East, Harding Hospital, and the Hospital Network.

(1) FY 2002 budgets were reduced by \$52.6 million representing interdepartmental transfers between hospitals.

(2) The portion of the Clinical Teaching Subsidy previously allocated to the Health System is being reallocated to support the clinical academic mission of the College of Medicine and Public Health. The FY 2002 6% State cut is reflected in the FY 2002 budget.

(3) Due to additional utilities, a change in capitalization policy, and an increase in personnel in environmental services.

**STATE SHARE OF INSTRUCTION AND STUDENT FEES
TEN YEAR TREND
COLUMBUS CAMPUS
(IN THOUSANDS)**

212

		State Share of Instruction (1)			Student Fees (2)		
		Subsidy	Dollar Change	Percent Change	Fees	Dollar Change	Percent Change
FY 1993	Actual	246,645	(11,476)	-4.5%	208,345	10,712	5.4%
FY 1994	Actual	254,355	7,710	3.1%	216,202	7,857	3.8%
FY 1995	Actual	267,000	12,645	5.0%	228,170	11,968	5.5%
FY 1996	Actual	275,834	8,834	3.3%	241,051	12,881	5.6%
FY 1997	Actual	287,565	11,731	4.3%	253,512	12,461	5.2%
FY 1998	Actual	303,057	15,492	5.4%	269,094	15,582	6.1%
FY 1999	Actual	311,787	8,730	2.9%	286,218	17,124	6.4%
FY 2000	Actual	324,623	12,836	4.1%	306,757	20,539	7.2%
FY 2001	Actual	337,754	13,131	4.0%	329,059	22,302	7.3%
FY 2002	Budget	322,683	(15,071)	-4.5%	363,150	34,091	10.4%
FY 2003	Budget	322,683	0	0.0%	407,433	44,283	12.2%
Ten Year Average Increase				2.7%			6.9%

(1) The State Share of Instruction includes Research Challenge and Success Challenge funds.

(2) Student Fees include Instructional, General and Non-Resident Fees.

HEADCOUNT ENROLLMENTS

AUTUMN QUARTER, 1992-2002

<u>Columbus Campus</u>								
Year	Undergrad	Graduate	Law	Dentistry	Medicine	Optometry	Pharmacy	Veterinary Medicine
1992	38,958	10,586	650	373	858	239	18	501
1993	37,062	10,934	665	359	856	241	19	508
1994	36,165	10,735	654	354	850	242	24	518
1995	35,475	10,495	678	360	863	249	36	521
1996	35,485	10,149	683	371	848	249	44	523
1997	35,647	9,907	666	380	855	247	41	535
1998	36,252	9,538	634	375	842	247	94	529
1999	36,092	9,153	628	372	832	248	147	531
2000	35,749	9,382	643	379	832	245	195	527
2001	36,049	9,452	655	395	844	245	300	537
2002	36,368	9,711	654	398	832	245	348	538

<u>Summary By Campus</u>							
Year	Columbus	Lima	Mansfield	Marion	Newark	ATI	Grand Total
1992	52,183	1,410	1,465	1,066	1,732	729	58,585
1993	50,644	1,348	1,412	1,046	1,675	713	56,838
1994	49,542	1,232	1,504	1,209	1,560	740	55,787
1995	48,677	1,244	1,359	1,171	1,548	783	54,782
1996	48,352	1,281	1,343	1,312	1,611	827	54,726
1997	48,278	1,374	1,460	1,105	1,676	925	54,818
1998	48,511	1,321	1,517	1,141	1,778	965	55,233
1999	48,003	1,323	1,573	1,176	1,883	1,031	54,989
2000	47,952	1,238	1,583	1,276	2,025	969	55,043
2001	48,477	1,356	1,495	1,390	2,079	940	55,737
2002	49,094	1,380	1,550	1,405	2,010	940	56,379

THE OHIO STATE UNIVERSITY
OFFICIAL PROCEEDINGS OF THE
ONE THOUSAND THREE HUNDRED AND EIGHTY-FIFTH MEETING
OF THE BOARD OF TRUSTEES

Columbus, Ohio, July 25, 2002

Pursuant to paragraph (B) of bylaw 3335-1-01 of the Administrative Code of The Ohio State University, the Board met upon the call of the Chairman, James F. Patterson, in a special meeting on Thursday, July 25, 2002, at 9:35 a.m., at The Ohio State University Longaberger Alumni House, Columbus, Ohio.

**

**

**

July 25, 2002 meeting, Board of Trustees

The Chairman, Mr. Patterson, called a special meeting of the Board of Trustees to order on July 25, 2002, at 9:35 a.m. He requested the Secretary to call the roll.

Present: James F. Patterson, Chairman, Zuheir Sofia, Robert M. Duncan, Karen L. Hendricks, Dimon R. McFerson, Douglas G. Borrer, Joseph A. Shultz, and Paula A. Habib.

--0--

Mr. Patterson:

Good morning everyone. I would like to call this special meeting of the Board to order. At this time, I will entertain a motion to go into executive session to consider a personnel matter.

Upon motion of Mr. Sofia, seconded by Ms. Hendricks, the Board of Trustees adopted the foregoing motion by unanimous roll call vote, cast by Messrs. Patterson, Sofia, McFerson, Borrer, and Judge Duncan, and Ms. Hendricks.

Mr. Patterson:

The meeting of the Board of Trustees will now reconvene. We have a resolution that has been prepared for the Board -- the election of Karen A. Holbrook as Ohio State's new president. May I have a motion?

ELECTION OF PRESIDENT

Resolution No. 2003-18

Synopsis: Election of Karen A. Holbrook as President of The Ohio State University is proposed.

WHEREAS it is the responsibility of the Board of Trustees, pursuant to section 3335.09 of the Ohio Revised Code, to elect the President of the University; and

WHEREAS the Board of Trustees established a Search Committee and charged it with responsibility for recommending to the Board one or more candidates for the Presidency of the University; and

WHEREAS in accordance with its charge the Search Committee did so recommend; and

WHEREAS the Board of Trustees has selected the individual it believes is the most highly qualified and suited to be the 13th President of the University:

NOW THEREFORE

BE IT RESOLVED, That Karen A. Holbrook be elected as the President of The Ohio State University; and

BE IT FURTHER RESOLVED, That President Karen A. Holbrook's initial term of office shall be for a period of five years, commencing on October 1, 2002; and

BE IT FURTHER RESOLVED, That the President's annual salary be set at \$325,000.00, with all benefits, allowances, privileges and perquisites attendant thereto and subject to such other arrangements and adjustments which may be mutually agreed upon; and

ELECTION OF PRESIDENT (contd)

BE IT FURTHER RESOLVED, That the Chairman of the Board of Trustees be authorized to negotiate with Karen A. Holbrook to formalize her relationship with The Ohio State University and, in so doing, to enter into any contractual relationship which he deems necessary and appropriate, consistent with this resolution; and

BE IT FURTHER RESOLVED, That any actions taken by the Board of Trustees or the Chairman to carry out this resolution prior to its effective date are hereby ratified and approved.

Upon motion of Mr. Sofia, seconded by Ms. Hendricks, the Board of Trustees adopted the foregoing motion by unanimous roll call vote, cast by Messrs. Patterson, Sofia, McFerson, Borrer, and Judge Duncan, and Ms. Hendricks.

--0--

CHAIRMAN'S REMARKS

Mr. Patterson:

For the record, I'd like to note that Trustees Dan Slane, Tami Longaberger, and Jo Ann Davidson -- Dan is in France and Jo Ann is in Washington, and Tami will be joining us for lunch -- have asked that they be reported to all of you as supporting this resolution. On that basis, I would like the records to reflect, Mr. Secretary, that Dr. Holbrook was chosen unanimously by the Board to be president of The Ohio State University.

Ladies and gentlemen, I would like to present to you Dr. Karen Holbrook.

Let me first make a few remarks, as we go forward in the program. In addition to chairing the Board, I also had the privilege of chairing the Search Committee. Today is an historic and exciting day for Ohio State University, as well as for the people of Ohio. The decision that we made will affect education, specifically higher education, in this state for literally generations to come. It is also a very special day for me in that I get to make this introduction to you. Before doing so, however, there are several comments that I want and need to make.

Again, I would like to thank Ed Jennings for delaying his retirement to serve as our interim president. Service that, while may be briefer than he thought, will continue into early fall. In working with Ed, I have noted that he has had a tremendous amount of enthusiasm. He has gotten back into this presidency business, and he likes it.

We anticipate that our new president will arrive on or about October 1. I know that Ed, along with everyone else on campus, will help to assure a smooth transition.

As many of you will recall, the search process began in early April, just days after Brit Kirwan announced his intention to return to Maryland. Early on, the Trustees took three key actions to set the search in motion. First, we named a broadly representative, 18-member Presidential Search Committee that has worked tirelessly and effectively for almost four months. We owe these committee members our most sincere thanks for their contribution to the University's future. Would those Presidential Search Committee members who are here today please stand and be recognized?

Second, we retained an outstanding search consultant, A. T. Kearney. A. T. Kearney was led by Dr. Jan Greenwood, principal of the firm. Jan unlocked doors and made contacts, and she also worked tirelessly and effectively on our search process. Jan, will you please stand?

CHAIRMAN'S REMARKS (contd)

Mr. Patterson: (contd)

Third, we prepared a Presidential Profile that identified six key attributes we wanted in a president. These attributes were: exemplary integrity, trustworthiness, and wisdom; superb interpersonal and communicative skills; a breadth and depth of intellect; a high level of energy; tenacity and judgment; and self-confidence. We sought a president who was strongly committed to our Academic Plan and would take us to the next level of academic excellence. We wanted to build upon the momentum that has been generated over recent years, not start over by pursuing a new direction.

The Search Committee reviewed well over 100 names, narrowing the list first to about 50 names, and meeting face-to-face with more than a dozen individuals. For the most part, these candidates were presidents or provosts at major American universities. As time went by, our thinking began to crystallize and we reached certain conclusions.

For example, it became increasingly clear that Ohio State would be best served with a president whose experience was at a public university and where the culture is quite different than at our private counterparts. Eventually, the committee recommended a small number of candidates to the Board of Trustees, which as you heard voted unanimously – and I should add, enthusiastically – for our next president, Dr. Karen Holbrook.

For obvious reasons, we are not going to identify any candidate other than our new president. I must note, however, that we looked at and met with a truly exceptional and diverse group of men and women. We were very impressed by the quality of the people that we met and, given Ohio State's needs at this point in time, believe that we have found the best of the best and the perfect fit in Dr. Holbrook. Why do I say that? Why did we select her to help us, to help lead us into the future, and to help us realize our aspirations?

First and foremost is Dr. Holbrook's total, unequivocal commitment to academic excellence and the Academic Plan. More than any person that we spoke to, Dr. Holbrook conveyed a thorough understanding of our vision to become a great teaching and research university, and what it will take to achieve it. One reference told us in a way that typified the glowing reports that we received about Dr. Holbrook, "If you want someone to hire the very best faculty, she is the one that you want."

We were also impressed by her passionate – and I do mean passionate – interest in Ohio State. She strongly believes that all the pieces are in place to realize our vision and that her entire life has prepared her to achieve this result. She is a native Midwesterner eager to return to her roots and to lead us to the greatness we seek.

A second and related factor is Dr. Holbrook's broad experience at three institutions – Washington, Florida, and Georgia – that bear many similarities to Ohio State. As an instructor, assistant professor, associate professor, associate dean, and professor of biological structure and medicine at the University of Washington, as vice president of research and dean of the graduate school at the University of Florida, and for the past four years as senior vice president for academic affairs and provost at the University of Georgia, Dr. Holbrook has consistently exemplified academic excellence.

One aspect of Dr. Holbrook's background was especially important, and that is the experience with academic medical centers, medical research, and

CHAIRMAN'S REMARKS (contd)

Mr. Patterson: (contd)

biotechnology. Medicine is an important part of our University, and biotechnology is critical to the future of Ohio State and the State of Ohio.

For those who don't know, the University of Georgia was founded in 1785 and is America's oldest state-chartered university. Like Ohio State, it is a land-grant institution. Their enrollment in the fall of 2001, totaled over 32,000 and its budget is approximately \$1.3 billion. *U.S. News & World Report* ranked it 18th in its 2002 list of the 50 top public universities.

At Georgia, Dr. Holbrook has served not only as provost, but also as professor of cell biology, and adjunct professor of anatomy and cell biology and medicine at the Medical College of Georgia. Last year, she helped create the Biomedical and Health Sciences Institute. She is a national authority in the field of dermatology.

She also played a key role in developing Georgia's Strategic Plan, analogous to our Academic Plan, which among other things includes a strong commitment to diversity and ambitious diversity goals. Working with the National Institutes of Health and the National Science Foundation, she strongly supported the efforts of faculty and research leaders to successfully expand Georgia's federal research funding.

At Florida, where she served as vice president of research as well as dean of the graduate school, Dr. Holbrook organized and chaired a meeting co-sponsored by the governor's office, the university system, private enterprise, and AAAS called, "The Future of Science and Technology in Florida: High Tech Florida Means Business."

A third reason that we were attracted to Dr. Holbrook is her extraordinary set of interpersonal skills. Her marks in developing positive relationships with faculty, staff, and students are more than high -- they are stratospheric. She bonds quickly with students, who immediately sense that she is interested in them and cares about them. It is easy to understand why, since she is someone whom you'll instantly like and trust. She has a wonderful way about her that will be very effective on and off campus. In short, she is very much a "people person."

Dr. Holbrook meets or exceeds all the attributes in our Presidential Profile. She brings boundless energy along with integrity, confidence, intellect, judgment, and, as I have said, superb interpersonal and communicative skills. She is also a strong supporter of service to the community and the land-grant institution. As you heard in the resolution, her own educational training was superb, with bachelor's and master's degrees in zoology from the University of Wisconsin and a Ph.D. degree in biological structure from the University of Washington.

She has also held leadership roles and participated extensively in the activities of professional and honorary societies, including: the American Association for the Advancement of Science, where she is a fellow and member of its board of directors; the American Association of Universities; the National Association of State Universities and Land-Grant Colleges; and the American Association of Medical Colleges; to name just a few. Her editorial and publication activities are impressive, and her service on faculty senates, economic development groups, search committees, and the like are truly extraordinary.

She has been deeply involved in national and regional efforts to strengthen graduate education in America, and has been active in economic development partnerships at the community and state levels.

CHAIRMAN'S REMARKS (contd)

Mr. Patterson: (contd)

Her husband, Jim, now retired, was an oceanographer and past deputy director of the National Oceanic and Atmospheric Administration's Pacific Marine Environmental Research Laboratory in Seattle. As an aside, Jim's also a golfer and we will be taking him to see the OSU Scarlet Golf Course this afternoon. And they have one son, James.

In summary, Dr. Holbrook is a high-energy and effective proponent of academic excellence and our Academic Plan. She builds constructive relationships with students, faculty, and others. She has a broad understanding of higher education today, with special knowledge of medicine and biotechnology. Her values are first-rate, and she will be a tremendous fit at Ohio State. Under her capable leadership, Ohio's flagship will continue under its quest for greatness.

With that, I present to you the thirteenth president of The Ohio State University, Dr. Karen Holbrook.

PRESIDENT'S REMARKS

Dr. Karen A. Holbrook:

Thank you very much. Thank you, Jim, especially for those more than generous remarks. They are greatly appreciated. I also want to thank especially all of the members of the Board of Trustees and the Search Committee for having the confidence in me to join you – the deans, the vice presidents, and all the academic leaders at this great University – and to help you lead this institution in the future.

It would be very hard to be any more excited than I am right now in standing before you and representing you in this wonderful University and in this new role, but especially for this great University, today and in the future.

Many who know me have heard me say over the last nine years that I have been a Southerner that I would never again live where the ground freezes. But that was said before I knew there'd be an opportunity to be part of the great Ohio State University, one of the truly outstanding public, land-grant universities of this nation. From the earliest days, according to Moos, our land-grant universities, "... were designed to support the infant republic, help citizens, and promote economic development as well as train minds and improve manners."

I'm not sure about the manners part, but we do support a nation that is no longer an infant republic, we do help citizens, we train minds -- our primary purpose -- and support economic development. As Jim has told you, I have had the privilege of studying and working at at least three land-grant universities. This is where I feel at home. Public institutions are vibrant, exciting, and ever-changing because they have both the mission and the charge to be relevant, to serve society, and to offer solutions in an increasingly complicated and complex world.

The Ohio State University stands especially tall among land-grant research institutions because it has it all, and I do mean all. It has the people, a broad array of undergraduate and professional programs, including an outstanding medical center complex, a statewide purview of education and outreach, and an unparalleled infrastructure. Thus, clearly the ability to provide the relevance that is so needed in this complex world. But by having this breadth and expansive an enterprise – this "broad gauge" idea espoused by the first Board of Trustees at

PRESIDENT'S REMARKS (contd)

Dr. Holbrook: (contd)

The Ohio State University – Ohio State also has a major responsibility to use these resources in ways that make a difference and to leverage such resources in times of constrained budgets, to reformulate and restructure our activities with new partners, to make the most of them, and to extend them in new ways.

Universities today are no longer on the periphery of the action and the economy, but they are front and center, and looked to in ever-broadening domains for direction, collaboration, and leadership. And universities must be able to respond with agility and a new sense of urgency. We are central to the "frontier of knowledge and innovation" and key to the success of Governor Taft's "Third Frontier Project."

A theme that runs through Ohio State's literature is "we're big." Yes, it is the first impression of Ohio State from any perspective. But in my view, the statement also needs to convey our connections with reality and our constituencies, internally across all of the colleges and programs, and externally with our community, our state, the nation, and the world. We're big and we're connected.

Our challenge is to ever increase the strength and quality of those connections so that our size is invariably equated with our excellence, our leadership among institutions of higher education, and our value to the future of the state. I'm impressed that our Academic Plan recognizes that we are "bigger," but that our goal is to promote "better."

The first year report shows that we are on track. The plan has the right vision, the right elements, and a sense of purpose. It is solid and translatable, and includes a refreshing sense of candor. It is a road map for each unit to focus its activities. As we move forward, we need to identify a quantifiable set of goals for our benchmarks, and those benchmarks should aim to exceed our peers in as many areas as possible.

As president, I'll be particularly interested in the following areas: fostering multi-disciplinary programs, including and extending beyond science; emphasizing outreach via pre-collegiate programs to broaden the pipeline for students who see OSU as a goal -- those who are the best students and those who are under-served; providing focused support for a select group of programs poised for excellence; continuing to enhance the undergraduate experience in today's context of student engagement and intentional learners with innovative programs that capitalize on the richness of the research environment; emphasizing the continuity of education over a lifetime -- not education in disparate packages or separate packages, but education that is overlapping and continuous throughout a lifetime; assuring that faculty award structure is aligned with institutional goals and values; and, finally, encouraging more and more of our resources to be self-earned and self-generated.

I'm impressed with the key strategies taught in the Individual Learning and Motivation course that we offer to our incoming students: 1) search the environment; 2) take reasonable risk; 3) take responsibility for your outcomes; and 4) use feedbacks. I take this advice as being equally applicable to new presidents.

Modern university leaders face a daunting array of pressures from various sources, but I'm confident that together we will meet all challenges with the full strength of this great University. Although it's been a very serious goal of mine to lead a great university, I never dreamed I would be fortunate enough to return to

PRESIDENT'S REMARKS (contd)

Dr. Holbrook: (contd)

the Midwest and cheer for the Buckeyes as they clean Michigan's clock 121 days from today!

Thank you very much.

CHAIRMAN'S REMARKS (contd)

Mr. Patterson: (contd)

A couple of asides, one of the things that we shared with Karen in our discussions with her was -- one might call them admonishments -- the greetings at Ohio State, now turns to a simple "Go Bucks!" We also told her that we were sure that she would look great in navy or yellow, but never, ever wear them together! To assure that, we have some things for Karen and Jim.

One can see appropriately enough that we have a Longaberger basket for Dr. Holbrook. Some of the gifts in the basket are for Jim, although some of the gifts in red are for Karen. We have a whole basket full of gifts. Here is a treasure that we would all like -- an autographed football. It reads, "To Dr. Karen Holbrook, 'Welcome to Ohio State and Best Wishes, Go Bucks!' -- Jim Tressel."

Dr. Holbrook:

Thank you.

Mr. Patterson:

Jim may like that. One other special thing for you is a memento that you can sit on your desk -- an Ohio State snow globe music box. We have one other thing for Karen. Karen's mother lives with her, so we have another bag for her mother.

Dr. Holbrook:

Oh, bless your heart. Thank you, she'll love it.

Mr. Patterson:

Thank you all for being a part of this very special and important historic day in Ohio State's history. Karen will be available in the Mount Leadership room in a few minutes to talk with the media. Thank you, again, for being here and being a part of today.

--0--

Thereupon the Board adjourned to meet Friday, September 6, 2002, at The Ohio State University College of Veterinary Medicine, Columbus, Ohio.

Attest:

William J. Napier
Secretary

James F. Patterson
Chairman

THE OHIO STATE UNIVERSITY
OFFICIAL PROCEEDINGS OF THE
ONE THOUSAND THREE HUNDRED AND EIGHTY-SIXTH MEETING
OF THE BOARD OF TRUSTEES

Columbus, Ohio, September 6, 2002

The Board of Trustees met at its regular monthly meeting on Friday, September 6, 2002, at The Ohio State University College of Veterinary Medicine, Columbus, Ohio, pursuant to adjournment.

**

**

**

Minutes of the last meetings were approved.

**

**

**

The Chairman, Mr. Patterson, called the meeting of the Board of Trustees to order on September 6, 2002, at 10:50 a.m. He requested the Secretary to call the roll.

Present: James F. Patterson, Chairman, Zuheir Sofia, Tami Longaberger, Daniel M. Slane, Robert M. Duncan, Karen L. Hendricks, Dimon R. McFerson, Joseph A. Shultz, and Paula A. Habib.

--0--

CHAIRMAN'S REPORT

Mr. Patterson:

I want to note a couple of things for you. First -- and you might think here is another thing from an agriculture guy -- I received an invitation and the opportunity yesterday to visit The Ohio State University Centers for Research at Piketon (South Centers), south of Waverly, Ohio. I'd never been there, so I had an opportunity to tour this facility. I couldn't stay for the whole tour, but what an interesting process. I keep being amazed.

We talk about a number of things that we think Ohio State should be doing. When you go and see facilities like that, and you hear what they're doing -- you know what? They're already doing some of those things. You think, "Okay, it's an agriculture and extension facility and yes, they are doing some of those things." They're doing some cutting-edge things, particularly in some of the areas that I work in. They are also doing things like raising shrimp. I had some of their shrimp and suggested to them that they need to do that in collaboration with vegetable crops. Sometimes when I eat shrimp, I feel the sauce is the most important part of it.

You should also know that they are doing some other great things. For the trustees, I couldn't help but think of David Brennan when I was visiting. One of the things that David had a lot of feeling for was this whole area of distance education and they are doing it. We have all sat in meetings here where we've talked about distance education in terms of teacher certification, in terms of nurses, the medical school, continuing education, and those kinds of things. They have a whole area serving sixteen Appalachian counties where, in cooperation with our College of Education, they are offering teacher certification.

There is a whole wing of the facility -- and they are adding to it -- strictly dedicated to a business incubator for innovative technologies and new economic development. This is an ongoing partnership with our SciTech Center and Business Technology Center. The point is, it is not just agriculture -- it is the whole of the University. Again, it was another one of those things that you don't often see. When you take the opportunity and go there you end up saying, "Oh my gosh, look at the things that Ohio State is doing and the breadth of the reach of the University." So I wanted to note that to you.

The second thing I want to touch on is the service of Bill Napier as our Board Secretary. Bill has worked for the University twice. Some years ago he was here and received his Ph.D. degree, and then he went off and on to other things. In 1996 we were discussing how to best fill the role of Secretary of the Board, and at that time I had the opportunity to be on that review committee. We interviewed different candidates and decided that Bill Napier was the gentleman that we wanted to be Secretary of the Board of Trustees.

At the conclusion of today's meeting, Bill's service as Secretary of the Board will officially end. I would say over the past several months, if not year or two, one of the areas that has been of utmost interest to the Board of Trustees has been in the whole area of government relations. It is so important that the University

CHAIRMAN'S REPORT (contd)

Mr. Patterson: (contd)

interact with these different groups – elected officials, regulation agencies, granting agencies, NIH, National Science Foundation -- in addition to the national associations that we belong to such as NASULGC and AAU. It is imperative -- and I'm sure that all of you who read the papers know how critical it is here in the State of Ohio – what and how the legislators, the Governor, and the Executive branch feels about Ohio State and that those relationships be the best that they can be.

So with that in mind, the Trustees supported the effort to increase this whole area of government relations and have asked Bill Napier to serve as acting vice president. It is on the agenda today to create the position and to name Bill to that position. There will be a search conducted on the position. This is a position that Bill Napier is extremely well-suited for, and so we're looking forward to working with him.

I want to acknowledge all of his assistance to the Board of Trustees these past years as secretary, and wanted to note it for the record.

Dr. William J. Napier:

Thank you, Mr. Chairman.

--0--

PRESIDENT'S REPORT

President Edward H. Jennings:

You know, Jim, bragging about the College of Food, Agricultural, and Environmental Sciences -- and I don't want to pump the Ag folks up too much -- but I think we also should recognize that we are embarking on the Gateway Project. A major part of the Gateway Project is dealing with the neighborhood around that area. That neighborhood, for those of you who know the area well, is truly one of the poorest neighborhoods in Columbus, and the College of Food, Agricultural, and Environmental Sciences' Extension operation is deeply involved in that neighborhood. As a matter of fact, they already have a facility in that neighborhood and are moving forward with that.

I say that in that context because this is something that Extension has been doing since the beginning of Ohio State -- going into underserved neighborhoods. In 1870 and 1880 it was in the very rural areas and today it is the inner city areas. OSU Extension is in downtown Columbus, associated with our Gateway Project, but also in downtown Cleveland and downtown Cincinnati. They are very active in the inner city. It is not just farming anymore, Mr. Chairman.

Today, as we approach the beginning of a new academic year, I'd like to give you a brief review of two initiatives in which we are making great progress to make Ohio State an even stronger and more valuable University to our students, faculty, and staff, as well as the people of the State of Ohio.

First of all, I'd like to talk about the work we are doing to further strengthen and improve efficiencies in Ohio State's arts and sciences core. The arts and sciences stand, truly, at the heart of our University's and any university's education program. Any great university must have, indeed, a core of outstanding faculty and top-level programs in the arts and sciences. In fact,

PRESIDENT'S REPORT (contd)

President Jennings: (contd)

America's public research universities are held in the highest regard around the world because of our ability to combine full liberal arts education with professional education and training. At Ohio State, we are blessed with a very strong arts and sciences core, and, indeed, many of our highest-ranked programs are in the arts and sciences and have been the recipients of our internal Selective Investment Awards.

In January, Executive Vice President and Provost Ed Ray announced the establishment of a special committee to review the structure of the arts and sciences at Ohio State. Unaware of other duties I might pick up a little later, Ed asked me to chair that group and I was pleased to do that. I might add that I was also pleased to resign that chair when I took on my interim president activities. I was also enormously pleased that the high quality of our arts and sciences faculty was reflected in the exceptional make-up of that committee.

The committee includes five senior faculty members from the arts and sciences, and I'd just like to name them to give you a flavor of the strength of this committee and their recommendations about to be presented: Kathy Borst-Jones, College of the Arts; Joe Ferrar, College of Mathematical and Physical Sciences; Barbara Hanawalt, College of Humanities; Richard Petty, College of Social and Behavioral Sciences; and Roy Stein, College of Biological Sciences. Also serving on that committee are people outside the arts and sciences but who are deeply affected by what arts and sciences accomplishes: Dean David Andrews, College of Human Ecology; Associate Dean Robert Gustafson, College of Engineering; and Professor Rebecca Jackson, College of Medicine and Public Health, who also represents the University Senate's Council on Academic Affairs. Those of you who have been around Ohio State will know that Rebecca is an M.D. in Dr. Sanfilippo's college, and her mom was an associate provost at Ohio State for many years.

The committee has been meeting regularly. It met with the current deans of the five colleges of arts and sciences individually; it has reviewed the organizational structure of arts and sciences at some of our benchmark institutions -- institutions like UCLA, University of Wisconsin, University of Michigan, and so forth -- and has spoken with colleagues and deans at those universities. It should be noted that the organizational structure at most of those benchmark institutions provides a more central role to the arts and sciences than it currently does at The Ohio State University.

Joe Ferrar, former chairperson of the Department of Mathematics and now chair of that committee, is a well-respected faculty member. He has been committed to and active in arts and sciences for more than thirty years. I am expecting an interim report from the committee this month and will seek appropriate consultation from the various affected parties on its recommendations at that time. Having strong arts and sciences activity at a university is indeed important to the entire university, and I want to ensure that we do everything we can to organize the arts and sciences in such a way to make that importance clear and meaningful to the entire University. We will have those recommendations this month, and we will hope to act on those recommendations with the appropriate consultation probably sometime in October or early November.

While our initiatives in the arts and sciences now represent part of our efforts to pursue the Academic Plan goals related to improving our academic programs and providing some enhanced services to our students, we are also making great progress in our goal of building a better-prepared student body. I am enormously

PRESIDENT'S REPORT (contd)

President Jennings: (contd)

proud to see the successful efforts that have been made across the University to bring in well-prepared students and to help them succeed.

As all of you know, each fall quarter since 1996, we have admitted a new freshman class that has been more academically prepared and higher achieving than any Ohio State class to come before them. That of course means that our current student body -- because they started in 1996 we hope most of them are out of here by now, but some of them are probably still here -- reflects that improving quality all the way along. Those students have progressed toward their degrees in record numbers. Again, not always in four years, but they are graduating. As a consequence not only is the freshman class strong, but the entire undergraduate student body is stronger than it's ever been. There are exceptional students doing remarkable work in the classroom, in the research lab, in the studio, and in the community.

This fall, our recruiters and the admissions office have had a much more difficult challenge than in times gone by. The overall size of the high school senior class nationwide is two percent smaller than the previous year, which by definition increases the competition for all students. Some indicators showed that prospective students tended not to travel as far to their universities in the wake of the 9/11 disaster. Despite these recruiting challenges, our Autumn 2002 freshman class that will arrive in a couple weeks will be virtually identical to the record-setting 2001 class in terms of academic development, academic achievement, and academic diversity.

Preliminary figures show that the average ACT score will be 25.2 -- the same as last year's, and that score equates to the top 18 percent nationally. That is to say, the average student is in the top 18 percent at Ohio State. The national average, incidentally is 20.8. As an indication, when I arrived at The Ohio State University in 1981, our freshman class' ACT score was slightly below the national average, and now it's in the top 18 percent. About one-third of the class will come from the top 10 percent of their high school class and two-thirds of the class will come from the top 25 percent of their class. The class is also very diverse racially and ethnically, and it includes students from every area of the state -- rural and urban -- as well as many students from across the nation as well as overseas.

In addition to the outstanding efforts of our recruiters, one important reason our class profile remained so strong this year was the University's commitment to shelter need-based students from the effects of the large tuition increases we were required to make. We dedicated in this budget \$3 million in grants and aid to cover 100 percent of the cost of the fee increases above the standard six percent. In fact, that was the very first item funded from that tuition increase. We are absolutely committed that no academically eligible student will be turned away from Ohio State for financial reasons.

Now, with that type of concern for our students and for academic excellence, I know that over the next several years, we will continue to improve the profile of our student body, as well as the retention and graduation rates of our students. And indeed, we will surpass, I believe, in the not too distant future, our friends up north and around the country. I know Martha, I'm stretching it too much, but we need to stretch ourselves.

I would also like to mention two very important appointments that are being made to help us more effectively deal with the financial challenges and the growing number of issues. I'd like to second Chairman Patterson's remarks about one of

PRESIDENT'S REPORT (contd)

President Jennings: (contd)

those appointments – the appointment of Bill Napier to the new position of vice president for Government Relations in an acting capacity.

Bill has worked in government relations, as Chairman Patterson indicated, since the 1970s and has worked enormously well with the General Assembly. He has essentially worked in higher education all of that time, except for a short sojourn into the Celeste administration in the 1980s. But he has worked for Ohio State and the region and has done a marvelous job. As Chairman Patterson indicated, we have put together a search committee chaired by Bobby Moser, and I'm confident that that search committee will move forward.

We've also asked University Treasurer Jim Nichols to serve as acting senior associate vice president for Business and Finance for the current fiscal year. In addition to his current duties as university treasurer, Jim will take on management responsibilities for Facilities Planning and Development, Physical Facilities, the minority business development initiative, and some other small duties. This move helps us to take better advantage of Jim's wide experience and knowledge and, at the same time, allows Bill Shkurti to devote more of his time to his role as chief financial officer during this time of financial stress. And indeed we are in financial stress. We are not only going to be working Jim very hard, but we're going to probably be working Bill Shkurti much harder than we've been working him in times gone by, even though he's going to have some help.

Before I conclude this morning, I'd like to mention just a few truly outstanding honors that Ohio State faculty have received in the past few weeks. First, Albert de la Chapelle, director of the Human Cancer Genetics Program at the Comprehensive Cancer Center and holder of The Leonard J. Immke, Jr. and Charlotte L. Immke Chair in Cancer Research, has won the 2002 Mauro Baschiroto Award for outstanding achievement in the field of human genetics. The award is presented annually by the European Society of Human Genetics, and Dr. de la Chapelle accepted that award in Strasbourg, France, this past week.

Another significant award went to Professor Sally Miller, a plant pathologist with the Ohio Agricultural Research and Development Center. She earned the American Phytopathological Society's 2002 International Service Award for her work improving pest management techniques in nations such as Bangladesh, the Philippines, and Ukraine.

I'd also like to mention two significant new studies taking place at Ohio State. First, we will receive \$9.1 million to carry out part of a major osteoarthritis study at the University College of Medicine and Public Health. The work is funded by the National Institutes of Health and several pharmaceutical companies, and Dr. Rebecca Jackson in endocrinology is serving as our principal investigator.

Also, the U.S. Department of Education has awarded Ohio State a \$1.5 million grant for a five-year program to recruit and retain students who are children of migrant, agricultural, or seasonal workers. Leading that effort will be Assistant Vice Provost of Minority Affairs Jose Villa. Dr. Villa is here today, and is coming back to Ohio State, and I'd like for him to stand and be recognized by us.

Jose is especially qualified to head this College Assistance Migrant Program (CAMP) because he himself is the son of migrant workers, and he continued to work with his family in the fields even while he attended college. Later he earned his Ph.D. degree at The Ohio State University. So he is coming back to us and

PRESIDENT'S REPORT (contd)

President Jennings: (contd)

we're very pleased that he is here to help many more children of migrant workers follow in his footsteps toward a brighter future.

Finally, on behalf of the entire University, I would like to extend my very grateful thanks and appreciation to Ohio State's long-time friend, and friend of mine, Betty Schoenbaum, for her generous gift of \$2.5 million to the College of Human Ecology to create an early childhood development center in the Weinland Park neighborhood just east of campus that we were mentioning earlier as part of the Gateway Project. This gift represents the largest gift ever to the College of Human Ecology, and the new center will be a key venue for linking Ohio State's resources with the needs of our immediate neighbors.

By the time of the next Board of Trustees meeting in October, The Ohio State University will have a new president, and my very brief tenure as interim president will have ended. So, I'd like to take this opportunity to express my gratitude to the Board and to all of the staff who have helped me greatly in these three months. Thank you for the opportunity to serve as interim president of this great University.

The Ohio State University has been the center of my professional career for the last twenty-odd years, and it was a special thrill for me last week to preside over a commencement ceremony where nearly 2,000 Buckeye graduates prepared to head out into the world with the enormous advantage of an Ohio State education. I mention that because commencement is what we're really about at a university. When we have commencement, that's the production of our product. Those of you who haven't come to a commencement – shame on you. It is one of the great celebrations of Ohio State. All of you faculty that aren't required to come to commencement, get out there. It's an interesting activity.

During these three months, I have spent much of my time meeting with and listening to faculty and they give me great hope for Ohio State's continued success in meeting the goals of our Academic Plan. Despite difficulties, our University is in excellent condition, and I can't overstate the tremendous value of our faculty to our students, to the institution, and to the State of Ohio. They are a great source of innovation and wisdom for our state's education system and for its overall economy.

I look forward to working with Dr. Holbrook for a smooth transition into her presidency. I'll watch with great interest as she leads this special University to greater heights. I am absolutely confident in her leadership, and I'm absolutely confident that we will move forward in magnificent ways under Dr. Holbrook's leadership. She is a great person, and I know all of you are going to fall in love with her just as I have.

Mr. Chairman and members of the Board, that completes my report.

Mr. Sofia:

That's wonderful – a great report. I meant to say something about the arts and sciences. I think this is a tremendous step for Ohio State. I applaud your commitment, Dr. Jennings, and all of the wonderful committee members. I really hope that we can accomplish this very fast. Thank you.

--0--

COLLEGE OF VETERINARY MEDICINE PRESENTATION

Mr. Patterson:

We want to thank the College of Veterinary Medicine and their dean, Glen Hoffsis, for hosting us today. I had the opportunity to be in this building for a University Foundation dinner and the dinner started about 30 seconds after they finished the building.

Glenn Hoffsis and I go back a long way. There are a number of you that I've known, but I think I've known Glen longer than anyone in the room. I thought maybe a bit of trivia might help you realize the relationship that the two of us have. Both of us met and married the two members of the 1963 AGR Sweetheart Formal that were on the court – they were the only two on the court! Now you can't say that you haven't learned something today.

Glen is one of those individuals for whom I have, for many years, had a tremendous amount of respect. I recall when the vacancy in the deanship occurred in the Veterinary College and I was on the Board. There were people that were contacting us, both within and outside of the University – people involved in the veterinary industry -- who thought that Glen was one of the greatest people in the world.

Glen has been a leader in much of the effort in some of the cutting-edge things, particularly as it has to do with cattle. He is tremendously respected. I have had the occasion to get to know a number of the other folks in the Veterinary College. I see Steve Reed in the back of the room. Some of these folks have been involved very much not only within the Veterinary College, but are recognized nationally and internationally -- people like Steve. In addition to that, these people have been leaders here on campus as well.

Glen, thank you, again, for hosting us today. I'd like to call on Glen now to tell us a little bit about the Veterinary College.

Dr. Glen F. Hoffsis: [Power Point Presentation]

Thank you, Jim. Chairman Patterson, members of the Board of Trustees, President Jennings, administration, and guests – welcome to the College of Veterinary Medicine.

It is a real pleasure and an honor to be able to host the Board meeting in our brand new academic building and especially in this Wexner Family Auditorium. I'd like to recognize Mr. Dan Patton, the head of our information technology section, for assisting me this morning.

The College of Veterinary Medicine goes back a long ways. We were one of the first colleges on the campus, starting in 1885. This slide shows the site of the very first veterinary hospital, which was located on Neil Avenue and sat on the site of the present Drees Laboratory. There are only twenty-seven colleges of veterinary medicine in the United States and four in Canada. They are all in major land-grant universities, and they're all very fine institutions. You can see that there is only one in Ohio and we cover a very large geographic area.

I'd like to say something about our students. Our curriculum is four years. We take 135 students per year; 90 of them are from Ohio, and the balance comes from an at-large pool. The majority of them have bachelor's degrees and many of them will have an advanced degree. It's very competitive. We have well over 1,000 applicants for those 135 slots, so these are talented students. For example, their average GPA upon entry is a 3.6, and their GRE is around 1900.

COLLEGE OF VETERINARY MEDICINE PRESENTATION (contd)

Dr. Hoffsis: (contd)

So they are very talented people indeed. They spend most of their first two years in didactic courses, doing basic science education.

I also wanted to reflect on our faculty. This slide shows Dr. Charles Capen, one of our faculty. He is one of a very few, maybe just two, members of the National Academy Institute of Medicine. He is also one of two members on our faculty who are University Distinguished Professors.

The Board has been interested in distance education, and I wanted to show you something here that Dan's pulling up live on the Internet. We call this "Web Vet," which is a supplement to our educational program. You can see some of the courses that our faculty and IT people have developed. He is going to pull up one here just as a demo, a case presentation – this Airedale – that a student can work through with a professor, and it's interactive. So you go through all of the signalmen, and the examination, and the treatment. Here we have in this radiograph normal vertebra, normal vertebra, normal vertebra – uh oh, this Airedale ate somebody's vertebra.

The final two years are spent mostly in clinical work, and we have our very own large veterinary referral hospital that sees about 30,000 patients per year. They're referred in from the public from all over the region – Ohio and beyond. Many species are involved – all of the farm animals, exotics, and companion animals of various sorts. Students are involved in every single one of these cases in some way – in doing the physical exam and being supervised in their work. One of the benefits in dealing with these large patients is that you can have everybody doing physical exams all at once.

This is Dr. Alicia Bertone, The Trueman Chair in Equine Clinical Medicine and Surgery – this is the very first endowed chair ever in the history of the College. You can see the teaching experience that our students are receiving and everybody's paying attention.

Graduation, as the president just pointed out, is the culmination. This is our oath and hooding ceremony. Awaiting these students is a large number of jobs – employers love Ohio State veterinary graduates. They all have three or four job opportunities. Most of them do companion animal practice or other kinds of practice. We have graduated some 7,000 in the history of our college, and we're proud of all of them. But I just wanted to point out a couple of them today, doing work that you might not realize veterinarians would be engaged in.

You want to talk about outreach? We have outreach. This shows Dr. Rick Linehan – he has the distinction of having fixed the Hubble telescope just earlier this year. And we're happy that he remembers his roots [slide shows OSU flag]. Dr. Linda Detwiler, at the USDA, is the veterinarian in charge of all of the control programs for preventing Mad Cow Disease from entering the country. It all falls on her to protect our food supply. Veterinarians are heavily involved in food safety and bio-security, and particularly in this time of bio-defense when many of the agents such as anthrax that are being talked about are basically animal pathogens.

And you've been hearing a lot about the West Nile virus. We are pleased that Dr. Bill Saville, an extension veterinarian on our faculty, is in charge of the entire State of Ohio's educational program with regard to the West Nile virus.

We're very proud of our research program and the unique place that we play in biomedical research. Our specific research focuses on animal diseases that can

COLLEGE OF VETERINARY MEDICINE PRESENTATION (contd)

Dr. Hoffsis: (contd)

serve as models of human disease. In doing this research, we can serve both man and animals. Our research is funded by the National Institute of Health, USDA, other federal agencies, and industry – pharmaceutical companies, etc.

The greatest success we've had in our research program was with the development of the feline leukemia vaccine by a group of our faculty a few years ago. The patent from this has yielded some \$20 million in royalties, which is still the highest yielding patent ever in the history of Ohio State. It was developed right here. Even more important was the fact that this not only helps with our knowledge about human disease processes with the retrovirus that causes both human and animal disease, but also it saved hundreds of thousands of lives of cats around the world.

We made a commitment a few years ago that we would build distinctive buildings in this college. We wanted to build buildings the quality of which would reflect the quality of the programs that they contain. So this shows our Galbreath Equine Center – the view that you would get from State Route 315. This building was opened in 1997.

This slide shows the building that you're in – our new academic building – and the Wexner Family Auditorium. We have another auditorium that is identical to this one and it is being built just across the corridor and is under construction at the moment. The building houses the administration, a grand lounge right outside the door, teaching laboratories, a computer laboratory, library, and research laboratories.

Also we're very proud of this space, yet to be developed, which will be an irrigated, beautifully landscaped plaza that we're hoping will be an extended classroom. It's going to be something that will enhance the learning experience and it will create a campus atmosphere for our college.

The complex has 110,000 square feet and cost \$26 million. We raised \$8 million in private funds of which, Jerry, we still have \$2.5 million to go. But we're going to make that.

A little bit about the make-up of our college – we're a top-tier ranked program. The last *U.S. News and World Report* ranked us 6th in the nation among all of these 27 and four Canadian schools – very fine institutions in their own right. So what we do is benchmark against our peer institutions. These are generally the colleges that rank above us and the blue shows our Big Ten counterparts. We benchmark against this group – we are shown in red.

In terms of numbers of professional students, we rank near the top. We have a large, robust program and we don't give up anything in quality. Our students would rank with anybody in our peer group. In numbers of faculty, we have a modest number, but our student faculty ratio because of that is the least favorable of our peer groups. If you look at tuition and state support per graduate, we have the lowest cost per graduate of not only our peer group, but of every single one of these twenty-seven veterinary schools in the country. So what we have here is an extremely high-quality educational program with the most efficient use of resources of anybody in the country.

So we reached a point a year and a half ago when we had reached and achieved all of our short-term goals. We embarked on a strategic planning process to figure out what the next steps are for us. We already recognized that we are a top-tier program and we're already doing a good job. What's the next step for

COLLEGE OF VETERINARY MEDICINE PRESENTATION (contd)

Dr. Hoffsis: (contd)

us? We decided, as a faculty, that we're going to stretch and push a little further and we created the vision that we're going to become the premier veterinary college in North America. Is that out of our reach? Is it too far? Some might think so. But we're in a place where it is within range; if we did certain things, we could get there. So we asked our faculty to characterize what would be the characteristics of the premier institution and how do we close the gap? What it is in a nutshell is if we obtain thirty additional faculty who are research intensive – 75 percent or so of their time devoted to research -- and if we can obtain \$20 million in sponsored research, because of our efficiency in the program we will become the premier veterinary college in North America.

So how are we going to do this? Under budget restructuring, here are the sources of funds: tuition, state subsidy, and the veterinary teaching hospital, which currently is going at about a \$1 million a month. Those sources of revenue are primarily brought to bear on the teaching program. But we have sponsored research with the indirects that they accrue, and also our development activity. This is where we're going to have to center most of our program for funding our strategic plan.

How have we done on this? We've basically been doing pretty well – we've about doubled in the last five years in cash gifts, which doesn't include any of the deferred gifts. So in the past five years, we've pulled in about \$15 million – you can build quite a bit of program with \$15 million. That included four endowed chairs – the very first endowed chairs in the entire history of our college and all in this timeframe -- two endowed professors, and 15 additional scholarships. So, Jerry, we're raising the bar. Our new goal is \$12 million in cash gifts, and if we can do this, we will become the premier college.

Well, we've been talking a lot about numbers and buildings and things, and it's not really about that. What it's really about is helping animals and helping people. This is a great profession, it's a great college, and this is a great place to build a career.

I appreciate all of you coming. You can take a look around the building. We invite you to do that and if you'd like a tour we'll arrange that. It's a pleasure to have you meeting in our facilities. Thanks very much. I'll take any questions you might have.

Ms. Hendricks:

How much in sponsored research did you have this past year? I mean, if you need \$20 million --

Dean Hoffsis:

We're doing right between \$5 million and \$6 million. Thank you very much.

--0--

IMPORTANCE OF FACULTY-STUDENT INTERACTION

Mr. Eddie Pauline:

First of all, I want to introduce Dr. Bernie Erven from the prestigious College of Food, Agricultural, and Environmental Sciences. Dr. Erven is here to accompany me with the presentation about faculty and student relationships and talk about it

IMPORTANCE OF FACULTY-STUDENT INTERACTION (contd)

Mr. Pauline: (contd)

from his perspective; not necessarily representing the views of all faculty, but singling out his own experience.

You're receiving a copy of a document that we put together a couple of weeks ago and have been circulating around the University to see what kind of feedback we get on it. The title of it is, "The Importance of Faculty and Student Interactions." This is a document that was put together as a proactive approach to deal with an important issue [inaudible] statistics along with it. If you go and survey students on campus they probably aren't talking about this, but we feel that it is very necessary in order to make the direction we're going with Ohio State positive.

The reason for the document is something that's being talked about by a lot of people and is a presence of a cultural change on campus. Obviously, we are a different institution from ten years ago or from even five years ago. We have selective admissions and we focus more on research. We struggle with research and selective admissions and maintaining our land-grant mission – it's definitely a different University. Our ACT scores have jumped up tremendously in the last five years and we, as an institution, are definitely changing.

There is a shift in priorities, as I mentioned before. It is now the job of faculty members not to fail you out of school, but to graduate you. Everyone is concerned about graduating us and making us productive, tax-paying citizens in the State of Ohio, and that definitely is a priority.

The other reason for the document is that we have noticed the importance of community around campus. Why are things like the campus riots happening? Are we losing pride for our school? People are becoming decentralized. As we can see from our budget model, it complements that. There is lots of pride for your specific college, but is there as much pride as there could be for the entire Ohio State University? That remains a mystery.

There is a lack of a central gathering point on campus. You can see many more individual cafeterias being put up across campus. No one goes to the Union anymore to eat together. That's kind of an interesting observation. There is much attention paid to the incoming class – the freshman. We complement them and we have programs for them. There's lots of attention paid to graduating students when they leave. But what about the people that are in the middle? Are we really having a dialogue with them and are we providing services to them that they really need in that time of being in limbo?

Why have we decided that faculty and student relationships are the foundation for improving all this? Well, as Dr. Jennings alluded to, the faculty are the main root of the University. Along with that root are the students – without faculty and students, then we don't have a University. It's a basic concept. As we prepare to work on the problems addressed earlier that I mentioned, it's important to note the budget restructuring too will become more important than ever.

I don't want to offend anybody, but we run the risk of students being seen as dollar signs for departments instead of actual students. That is a problem that no one probably wants to have, but is maybe inherent with that concept of budget restructuring and just generating revenue from how many students you have in the class. The faculty and their relationship with the students is probably the best preventative measure to avoid that sort of idea. As long as students and faculty are having a relationship, they're not going to be seen as these dollars signs.

IMPORTANCE OF FACULTY-STUDENT INTERACTION (contd)

Mr. Pauline: (contd)

They're going to be seen as real people, real students, real learning machines, and that's going to help the situation.

Other reasons that faculty and student relationships should be the foundation for improvement is because we have selective admissions. Students are better prepared for Ohio State. They've been dealing with a lot of people in their high school experience. The reason they are successful is because of the relationships that they've had with other people.

For example, I consider myself a pretty successful student and I didn't just make up all this stuff. I have talked with people, I've had relationships with people that are passionate about things, and it's inspired me. If you're not getting that sort of relationship from your University experience, that's something that needs to change.

Lastly, and probably the most important reason that student-faculty relationships are important, is because of the aspect of community that I mentioned earlier. Too often students, faculty, staff, and the administration are off in their own worlds worrying about their own concerns, and enhancing faculty-student relationships could be a vital first step in improving that mentality.

So how do we go about doing this? In your handout -- I'm not going to go over each one specifically -- we mentioned five specific bullet points that talk about things that we think could help inspire this improved relationship. They range from ideas of faculty being more of advisory people for students. Not in the sense of being technical advisors, like dealing with schedules and filling out the proper graduation paperwork, but being more of an intellectual advisor. Someone students can go to to have these conversations about the things that they're interested in, about the things that they're practicing in class. If we can make students interested in the stuff that they're talking about in class, then definitely they can carry that conversation outside of the classroom and have that conversation with more people.

Other ideas that we had in the document include things like having students more involved in faculty-monitored research. We feel that if students can work with faculty members in a research setting that will inspire more research commitment from the students in the future. Getting faculty more involved in extracurricular activities outside of the classroom. We found that 80 percent of your time here at Ohio State is probably spent outside the classroom. The faculty need to be involved in that and if we're only seeing faculty members 20 percent of the time, that needs to change as well.

So the reason we don't have these good relationships now is a shift in priorities. The demands placed on faculty members are focused on research and publishing documents. And as human beings, that doesn't allow them the time to have these nice relationships with students. We need to change that and probably the best way to do that -- to create this incentive for having these better relationships -- is to change the reward structure for faculty members.

Right now, the formula is set up that you get rewarded for your research. And that's fine and good, and that's important because we are a research institution. But, at the same time, we have a responsibility to educate people. We have a responsibility to create mature, committed, community-minded adults, and we don't want to lose out on that opportunity by not letting these students experience the greatness the faculty members possess. So we want to make sure that we can guarantee that mentality.

IMPORTANCE OF FACULTY-STUDENT INTERACTION (contd)

Mr. Pauline: (contd)

While I was talking to faculty members about this, there was a sense that I was trying to put all of this on to the faculty members, that it was their responsibility to solve all these problems. That's simply not true. We at least want the faculty members to create an inviting atmosphere for the students to approach them. We want to end the mentality where students don't feel comfortable going into office hours with faculty members. Some faculty members say that some of their loneliest times at this University are spent during their office hours each week and that's unacceptable.

At the same time, if the faculty member comes into a classroom, doesn't introduce him or herself, goes on to the lecture, and runs out of the room quickly after class, that really doesn't create an inviting atmosphere. What did you learn about that person? What are they passionate about? Once you have that personal relationship set up with this faculty member, then you're more inspired to go and find out more from this faculty member. But after that point, it is totally up to the students. It's a dual responsibility here. The faculty members need to want this relationship and the students need to realize that there is a huge benefit gained from talking with their faculty members and learning from them.

We have good examples of this happening within Ohio State right now. The College of Food, Agricultural, and Environmental Sciences seems to be doing the right thing. They have a long tradition of creating a lot of good faculty-student interactions. There are different departments around the University – geology is one. Since there are only 30 geology majors, you really can have some good conversations with your faculty members. Political Science is another one that does a really good job.

I mentioned honors before as a good example, but that's probably not the best example. We want to make sure that not only the students with the 3.9 GPA are getting this faculty-student interaction, but that we're allowing even students with the 2.1s and the 1.5s the chance to go in and talk to their faculty member who would perhaps inspire them to become more passionate about what they're doing. It seems like those people are being left out. So we want to change that.

Again, it is a two-part, dual role. We want to make sure that the faculty members are communicating this to each other, as well as students communicating to other students about how important it is to go in and realize how much you can learn from your faculty member.

Probably my main point in this whole thing is that we will not fix all our problems at this University by getting better students to come here. We have to change fundamentally as a University and realize all the constituents involved. All those people need to change along with the student body that's coming in and changing.

We must realize structure and statistics aren't enough to address the serious challenges we face with becoming the best university we can be. Our success is dependent on the people at this institution, the roots of the University, which are, again, our faculty and students. There's a great amount of potential there and I leave it up to the administration to figure out how exactly to address this proactive concern that we as students have.

I want to now refer to Dr. Erven, who will talk about his experience with this.

IMPORTANCE OF FACULTY-STUDENT INTERACTION (contd)

Dr. Bernard L. Erven:

Thank you, Eddie. I think Eddie and Joe together have captured well the issues. I certainly think they're right on track. The challenge of accomplishing better faculty-student interaction relationships is very complex, very long-standing, and won't easily be changed. I think he is correct in putting emphasis on the reward system, but I would interpret reward in this context broadly, not narrowly.

From my standpoint as a faculty member, part of the reward system is having contact with excellent students, interesting students, and students who challenge me. I'm not talking about 3.8s and 3.9s – one of my favorite students of all time graduated with a 2.0000. He did not have one higher grade than he needed. But in the four years I knew him, I tremendously enjoyed what he brought as issues, discussions, and questions.

I think students need community – as Eddie has pointed out. But I'm not talking about faculty conducting open lounge hours with a microwave that produces popcorn. I'm talking about faculty that are comfortable doing it in a way that fits their programs, their personalities, their work life, their research program, or their teaching. It says "relationships." This is highly personal. This is not about a recipe to give all faculty. Drinking beer for some people is exactly the right thing to do with students. For others it's not. For others it is the laboratory, for some it is the office, for some it is the home, or the old-fashioned fireplace chats. It all works if faculty and students are committed to make it work and therein, I think, lies our real challenge.

But let's not forget – students need challenging. This isn't about being a friend. It is sometimes about telling students what they don't want to hear, asking questions that they don't want to be asked, and about raising issues that they didn't know were on the agenda.

I can relate to that personally. In 1956, when I was a freshman, I had a Professor Cook. I can remember the conversation as if it happened yesterday. He told me I had the wrong major and the wrong university. And he said, "Why don't you get the hell out of here?" He got my attention – I was six months out of high school. I did change majors and I did change universities, and I'm forever grateful. When I was working on my master's program, I had a faculty member who convinced me that my career objectives were far too modest. I'm forever grateful to that faculty member.

Now, interestingly, I would guess that virtually everybody in this room could name one or two faculty members who played similar roles at some time in your career. And sometimes not in a very comfortable way, but in a way that sometimes changed your lives in important ways. So I emphasize that there's a need here that we can help address.

One of the saddest things I face as a faculty member is a graduating senior who comes to my office and says, "Can I use you as a reference?" And I say, "I don't know you. I had you in two classes. One class had 90 students, the other had 65. You've never been here before; you aren't even in my major – you're from another department." He says, "I've got to have a name. I know you better than anybody else." Isn't that sad?

I would hope that every student by the time you need a reference, by the time you need someone to challenge, by the time you need someone to celebrate your accomplishment of a 2.0000 and a degree that we will be able to say, "Yes, I knew Kendra...I knew Professor Brown...I knew him...I knew her. She made a difference in my life." That's what faculty-student interaction is about. Not about

IMPORTANCE OF FACULTY-STUDENT INTERACTION (contd)

Dr. Erven: (contd)

a recipe, not about guidelines, and certainly not about curricular requirements – the Internet does that much better than any faculty member. It's about a relationship. I endorse what Eddie and Joe are saying to you.

Mr. Pauline:

Thank you, Dr. Erven. Again, this is a very proactive approach to solving some problems here. Perhaps not problems, but definitely a way to accomplish the goals that we want to accomplish. We want to be a great institution, we want to be top tier, we want, we want, we want – but, again, we need to come back to basics for a minute and realize that these relationships that we have with the people that surround us are going to really push us over the edge. I hope somehow this could be made a priority, worked into the Academic Plan – something that will inspire people to focus on this and to realize what it can do for our University.

So, from there, I'll take questions.

President Edward H. Jennings:

Eddie and Bernie, thank you. For the last several months, and really the last couple of years, we've been talking about the Academic Plan, about reform, about Arts and Sciences, and we're moving that forward. We've been talking about selective admissions and we've been talking all these good things. We've been talking about research faculty and so forth, and making tremendous progress.

If I can paraphrase what Eddie and Bernie are saying -- and what Brit Kirwan said in his last meeting is -- the debate is over as to what kind of university this institution should be. It is no longer every man's university where our job as faculty members -- 25 years ago -- particularly for freshman and sophomores -- was to flunk them out. Our job was to flunk them out because we had 9,000 freshmen and we couldn't handle 9,000 freshmen.

To do a selective admissions job today, where we are saying if you're accepted to Ohio State you are qualified to graduate, it's a very different attitude. And what that means is, when Eddie is a freshman and comes in and gets a "D" on his chemistry class we used to ignore him. If he came in, we'd ask him a few questions. Now all we've got to do is say, "Eddie, why'd you get that D?" We need to bring him in and start developing those relationships early on.

When you talked about the dollar sign that a student had. Well, folks, if we're talking about a freshman class that is competitive with a Michigan or a Northwestern, that means the competition is getting very stiff. It means that our freshman can go to any university in the world, any university in the nation. And the best recruiters for our students are our students. If our students say, "You go to class and you get a good research professor, but I've never seen him," some of them aren't going to come. We've got to change. I think it's absolutely delightful that here is a student body president lecturing us on what we ought to do. He is dead right. Bernie's also right – it isn't going to happen overnight and Eddie knows that, too.

Mr. Pauline:

Yes.

IMPORTANCE OF FACULTY-STUDENT INTERACTION (contd)

President Jennings:

But folks, we do have to develop a different attitude about our student body.

Mr. Sofia:

Dr. Jennings, we listened to Ed yesterday in the Student Leadership Committee meeting and really observed also that we have a great Academic Plan. But one important thing that was absent is student-faculty interaction – no comment whatsoever in the entire Academic Plan. So I hope, as we are reviewing this, we are going to take care of this small mishap. By the same token -- I share what Eddie and Bernie are saying -- it's such a critical relationship to have. I loved my undergraduate school, but I hated every minute of my graduate school education because it was exactly what Ed said.

Ms. Longaberger:

I wanted to thank the two of you for your comments and certainly agree with them. As a student at Ohio State when there were 68,000 students here -- and I was a student when President Jennings was here the first go-around -- I was shocked that that was the goal of the professors. Mr. President, if you would please write my mother a note and explain my grades my freshman and sophomore year; it would be helpful to me!

President Jennings:

You're not implying that you were that 2.0 student that Bernie was talking about?

Ms. Longaberger:

My transcript is sealed, I understand.

Mr. Patterson:

Thank you very much.

(See Appendix XII for background information, page 325.)

--0--

CONSENT AGENDA

President Edward H. Jennings:

We have 20 resolutions on the Consent Agenda today and I would like to ask that #8, the Naming of the 4-H Building, and #16, Appointment and Reappointment of Investment Managers, be considered separately. Please note that #6, Uniform Selective Admissions for All Quarters, is being tabled for further review. Unless there are any objections, I would like to recommend the following 18 resolutions to the Board:

APPOINTMENT TO THE ACCESS HEALTH COLUMBUS BOARD

Resolution No. 2003-19

WHEREAS AccessHealth Columbus is a non-profit organization established to improve access to healthcare for individuals living in Franklin County who face difficulties in obtaining healthcare services, such as the lack of insurance, cultural barriers, and living in underserved areas; and

APPOINTMENT TO THE ACCESS HEALTH COLUMBUS BOARD (contd)

WHEREAS The Ohio State University Health System has a long tradition of serving everyone who lives in Franklin County; and

WHEREAS the coordination of efforts amongst many private and public service providers will improve access to healthcare and will assist the Health System in achieving its mission of providing accessible care; and

WHEREAS the appointment of a representative from the Health System to the Board of Directors of AccessHealth Columbus will assist in this coordination:

NOW THEREFORE

BE IT RESOLVED, That R. Reed Fraley, Vice President for Health Services, is hereby authorized to serve on the Board of Directors of AccessHealth Columbus, and in his capacity as a director of AccessHealth Columbus is hereby authorized and instructed to represent the interests of the University as part of his official responsibilities to the University, entitling him to any immunity, insurance or indemnity protection to which officers or employees of the University are, or hereafter may become, entitled.

UNIVERSITY HOSPITALS BOARD APPOINTMENT

Resolution No. 2003-20

Synopsis: Approval of an appointment to the University Hospitals Board is proposed.

WHEREAS the Board of Trustees on November 30, 1979, approved the establishment of a University Hospitals Board; and

WHEREAS the membership of the Hospitals Board was approved on April 4, 1980, and has been subsequently amended; and

WHEREAS there is one vacant citizen member position on the University Hospitals Board:

NOW THEREFORE

BE IT RESOLVED, That the following individual be appointed as a citizen member of the University Hospitals Board, effective immediately for a three-year term:

George A. Skestos

**AMENDMENTS TO THE *BYLAWS AND RULES AND REGULATIONS*
OF THE MEDICAL STAFF OF THE OHIO STATE UNIVERSITY HOSPITALS**

Resolution No. 2003-21

Synopsis: The amendments to the *Bylaws and Rules and Regulations of the Medical Staff* of The Ohio State University Hospitals are recommended for approval.

WHEREAS The Ohio State University Hospitals Board pursuant to bylaw 3335-101-04 of the Hospitals Board Bylaws is authorized to recommend to the Board of Trustees the adoption of amendments to the *Bylaws and Rules and Regulations of the Medical Staff* of The Ohio State University Hospitals; and

**AMENDMENTS TO THE BYLAWS AND RULES AND REGULATIONS
OF THE MEDICAL STAFF OF THE OHIO STATE UNIVERSITY HOSPITALS (contd)**

WHEREAS the proposed amendments to the *Bylaws and Rules and Regulations of the Medical Staff of The Ohio State University Hospitals* were approved by the University Hospitals Board on July 25, 2002, as attached:

NOW THEREFORE

BE IT RESOLVED, That the attached amendments to the *Bylaws and Rules and Regulations of the Medical Staff of The Ohio State University Hospitals* be adopted as recommended and approved July 25, 2002, by the University Hospitals Board.

(See Appendix XIII for background information, page 327.)

**AMENDMENTS TO THE BYLAWS OF THE MEDICAL STAFF OF THE ARTHUR G. JAMES
CANCER HOSPITAL AND RICHARD J. SOLOVE RESEARCH INSTITUTE**

Resolution No. 2003-22

Synopsis: The amendments to the *Bylaws of the Medical Staff of The Arthur G. James Cancer Hospital and Richard J. Solove Research Institute* are recommended for approval.

WHEREAS The Arthur G. James Cancer Hospital and Richard J. Solove Research Institute Board pursuant to bylaw 3335-109-02 of the James Cancer Hospital Board Bylaws is authorized to recommend to the Board of Trustees the adoption of amendments to the *Bylaws of the Medical Staff of The Arthur G. James Cancer Hospital and Richard J. Solove Research Institute*; and

WHEREAS the proposed amendments to the *Medical Staff Bylaws* were previously endorsed and ratified by The Arthur G. James Cancer Hospital and Richard J. Solove Research Institute Board on August 6, 2002:

NOW THEREFORE

BE IT RESOLVED, That the attached amendments to the *Bylaws of the Medical Staff of The Arthur G. James Cancer Hospital and Richard J. Solove Research Institute* be adopted as recommended by The Arthur G. James Cancer Hospital and Richard J. Solove Research Institute Board.

(See Appendix XV for background information, page 349.)

**ESTABLISHMENT OF VICE PRESIDENT FOR GOVERNMENT RELATIONS POSITION
AND AMENDMENTS TO THE BYLAWS OF THE BOARD OF TRUSTEES**

Resolution No. 2003-23

Synopsis: Establishment of a vice president for Government Relations position and amendments to the *Bylaws of the Board of Trustees* is proposed.

WHEREAS competition for increasingly scarce resources has made it imperative that the University's case for federal and state support must be made strategically and effectively; and

**ESTABLISHMENT OF VICE PRESIDENT FOR GOVERNMENT RELATIONS POSITION
AND AMENDMENTS TO THE BYLAWS OF THE BOARD OF TRUSTEES (contd)**

WHEREAS assigning this important responsibility at the vice presidential level will demonstrate the university's commitment to effective advocacy and policy-guided relationships with government officials, representatives and agencies; and

WHEREAS the establishment of the position of vice president for Government Relations is recommended, with the delineated responsibilities set forth in paragraph (O) of bylaw 3335-1-03 of the Administrative Code, as follows:

Amended Bylaw

3335-1-03 Administration of the university.

(O) Vice president for government relations. The major area of responsibility and authority of the vice president for government relations shall be the administration of all aspects of the university's relationships and dealings with federal, state and local government officials, representatives and agencies to advance the university's mission and substantive agenda. Without limiting the generality of the foregoing, the vice president for government relations shall, under the direction of the president and with the approval of the board of trustees, advise the president and senior university leadership on all legislative and regulatory matters impacting the university's interests; develop strategies to effectively advance the university's academic agenda with policymakers and funding agencies, particularly at the federal level; maintain regular and effective substantive communications between the university and government officials at all levels; and develop support for the university's agenda by engaging the interest and commitment of advocacy groups, institutional colleagues, policymakers and Ohio's citizens. The vice president for government relations shall report to the president of the university. The vice president shall coordinate the university's policies and contacts involving federal, state, and local government including government agencies as they relate to university priorities among the various internal unit directors of government relations.

NOW THEREFORE

BE IT RESOLVED, That the vice president for Government Relations position is hereby approved, effective immediately; and

BE IT FURTHER RESOLVED, That the Secretary of the Board of Trustees is hereby authorized and directed to incorporate this change in the applicable sections of the *Bylaws of the Board of Trustees*.

**APPOINTMENTS TO THE ENGINEERING EXPERIMENT
STATION ADVISORY COUNCIL**

Resolution No. 2003-24

WHEREAS the Engineering Experiment Station is under the control of the Board of Trustees of The Ohio State University; and

WHEREAS according to statute 3335.27 of the Ohio Revised Code, there shall be an advisory council made up of the director of the Engineering Experiment Station and six members appointed by the Board, chosen from the faculty of the College of Engineering; and

WHEREAS this Engineering Experiment Station Advisory Council "shall select suitable subjects for investigation, apportion the available funds, and with the consent of the Board may provide for the dissemination of the results to the people of the state:"

**APPOINTMENTS TO THE ENGINEERING EXPERIMENT
STATION ADVISORY COUNCIL (contd)**

NOW THEREFORE

BE IT RESOLVED, That upon the recommendation of Interim President Edward Jennings, pursuant to the request of James C. Williams, Dean of the College of Engineering and Director of the Engineering Experiment Station, The Ohio State University Board of Trustees, acting in accordance with the requirements of the Ohio Revised Code Section 3335.27, hereby appoint the following individuals to serve on the Engineering Experiment Station Advisory Council:

<u>Name</u>	<u>Title</u>	<u>Proposed Term</u>
Cheena Srinivasan	Professor of Mechanical Engineering	3 years (9/1/2002 - 8/31/2005)
Dhabaleswar Panda	Professor of Computer and Information Science	3 years (9/1/2002 - 8/31/2005)
James C. Williams	Dean of Engineering and Honda Chair	3 years (9/1/2002 - 8/31/2005)

NAMING OF CONFERENCE ROOM

Resolution No. 2003-25

Synopsis: Naming of the conference room located in the Waterman Headquarters Building located at 2490 Carmack Road on the Columbus Campus is proposed.

WHEREAS the Board of Trustees has authority in naming of all buildings and structures at The Ohio State University, including internal spaces, as set forth in paragraph (F) of rule 3335-1-08 of the Administrative Code; and

WHEREAS upon the recommendation of the vice president and executive dean of the College of Food, Agricultural, and Environmental Sciences, the faculty, and the Ohio Vegetable and Potato Growers Association, it has been proposed to name the conference room for Gene and Dorothy Wittmeyer; and

WHEREAS Gene Wittmeyer began his career with The Ohio State University as an extension specialist in 1950, became a full professor in 1959, and retired in 1984; and

WHEREAS Dorothy and Gene Wittmeyer were involved with the Ohio and Franklin County Vegetable and Potato Growers Associations for over 50 years; and

WHEREAS Gene Wittmeyer is a member of the Ohio Agricultural Hall of Fame and has been a tireless and dedicated servant to Ohio State and the vegetable industry:

NOW THEREFORE

BE IT RESOLVED, That the aforementioned conference room shall be named the "Gene and Dorothy Wittmeyer Conference Room."

**REVISION OF THE CLASSIFIED CIVIL SERVICE RULES OF
THE OHIO STATE UNIVERSITY**

Resolution No. 2003-26

Synopsis: Adoption of edited *Classified Civil Service Rules* to as the first step in the Classified Civil Service modernization project is proposed.

WHEREAS the University must abide by Ohio Revised Code Chapter 124 regarding civil service employment; and

WHEREAS the University is modernizing its classified civil service rules for greater flexibility and updating the classification title deck; and

WHEREAS the University has complied with Ohio Revised Code Section 111.15 and the edited classified civil service rules have completed a voluntary 31-day notice and comment period without any substantive comments from the University community:

NOW THEREFORE

BE IT RESOLVED, That administrative rules 3335-51-01, 3335-51-02, 3335-55-01, 3335-55-03, 3335-55-06, 3335-55-08, and 3335-65-12 are hereby adopted as revised.

(See Appendix XVI for background information, page 375.)

HONORARY DEGREE

Resolution No. 2003-27

Synopsis: The awarding of an honorary degree to William F. Ganong is recommended for approval.

WHEREAS the Committee on Honorary Degrees and the University Senate, pursuant to rule 3335-5-488 of the Administrative Code, have approved for recommendation to the Board of Trustees awarding of an honorary degree as listed below:

William F. Ganong

Doctor of Science

NOW THEREFORE

BE IT RESOLVED, That the above honorary degree be awarded in accordance with the recommendation at a time convenient to the University and the recipient.

PERSONNEL ACTIONS

Resolution No. 2003-28

BE IT RESOLVED, That Resolution 77-92 and the provisions of the February 6, 1959 Report of the Committee on Retirement and Insurance, calling for "Principal Administrative Officials" to be relieved of their administrative assignments at age 65, be waived to allow for the appointment of Robert F. Lawson as Director of the School of Educational Policy and Leadership; and

PERSONNEL ACTIONS (contd)

BE IT RESOLVED, That the personnel actions as recorded in the Personnel Budget Records of the University since the July 12, 2002 meeting of the Board, including the following Appointments, Promotions, Appointments/Reappointments of Chairpersons/Directors, Leaves of Absence Without Salary, Professional Improvement Leaves, Promotions/Tenure/Reappointments, and Emeritus Titles, as detailed in the University Budget be approved.

BE IT FURTHER RESOLVED, That the Medical Staff Appointments/Reappointments approved August 6, 2002, by The James Cancer Hospital Board, be ratified.

Appointments

Name: GARY BOS
Title: Professor (The Frank J. Kloenne Chair in Orthopedic Surgery)
Department: Orthopaedics
Change in Term: August 13, 2002, through June 30, 2006

Name: RUSSELL H. FAZIO
Title: Professor (The Harold E. Burt Chair in Psychology)
Department: Psychology
Term: July 1, 2002, through June 30, 2007

Name: WILLIAM J. NAPIER
Title: Acting Vice President for Government Relations
Office: Office of the President
Effective: September 6, 2002
Present Position: Special Assistant for Government Relations and Secretary of the Board of Trustees

Name: THOMAS A. SCHWARTZ
Title: Associate Professor (Willard M. Kiplinger Chair in Public Affairs Reporting)
School: Journalism and Communication
Term: October 1, 2002, through June 30, 2003

Name: JOSE S. VILLA
Title: Assistant Vice Provost
Office: Minority Affairs
Effective: July 1, 2002
Present Position: Education Program Specialist, Office of Migrant Education, U.S. Department of Education

Name: DAVID WINWOOD
Title: Associate Vice President for Knowledge Transfer and Commercialization
Office: Research
Effective: October 15, 2002
Present Position: Associate Vice Chancellor and Director, Technology Transfer, North Carolina State University, Raleigh, NC

Promotions

Name: ROBERT A. BORNSTEIN
Titles: Senior Associate Dean for Academic Affairs and Secretary of the College
College: Medicine and Public Health
Effective: September 1, 2002
Present Position: Associate Dean for Academic Affairs and Secretary of the College

PERSONNEL ACTIONS (contd)

Promotions (contd)

Name: SUSAN F. JABLONSKI
Titles: Associate Vice President/Chief Communications Officer
Office/College: Health Sciences/Medicine and Public Health
Effective: September 1, 2002
Present Position: Assistant Vice President for Health Sciences and Chief Communications Officer, College of Medicine and Public Health

Name: JOAN E. PATTON
Titles: Associate Vice President and Chief Operating Officer/Chief Financial Officer
Office/College: Health Sciences/Medicine and Public Health
Effective: September 1, 2002
Present Position: Senior Director, Business and Administration, College of Medicine and Public Health

Appointment of Chairpersons/Director

August 13, 2002, through June 30, 2006 (change in effective date)

Orthopaedics	Gary Bos
September 1, 2002, through June 30, 2006	
School of Educational Policy and Leadership	Robert F. Lawson
Neuroscience	Michael S. Beattie
Psychiatry	Radu V. Saveanu
Sociology	Robert L. Kaufman

Reappointment of Chairperson/Directors

July 1, 2002, through June 30, 2003

Veterinary Hospital	Richard M. Bednarski
---------------------	----------------------

August 1, 2002, through August 31, 2002

School of Educational Policy and Leadership	James W. Altschuld*
---	---------------------

October 1, 2002, through September 30, 2006

Agricultural, Environmental, and Development Economics	Alan J. Randall
---	-----------------

*Interim

Reappointment of Principal Administrative Official

DAVID W. ANDREWS, Dean, College of Human Ecology, effective July 1, 2003, through June 30, 2008, pursuant to rule 3335-1-03 (R) of the Administrative Code.

Leaves of Absence Without Salary

HARVEY M. FRIEDMAN, Distinguished University Professor, Department of Mathematics, effective Autumn Quarter 2002, to accept a visiting professorship in the Department of Philosophy at Princeton University.

PERSONNEL ACTIONS (contd)

Leaves of Absence Without Salary (contd)

JOHN A. RIZZO, Professor, School of Public Health and Department of Economics, effective Autumn Quarter 2002, Winter Quarter and Spring Quarter 2003, to accept a visiting professorship in the Department of Policy Analysis and Management at Cornell University.

STEVEN CONN, Associate Professor, Department of History, effective Winter Quarter, Spring Quarter, and Autumn Quarter 2003, to accept a visiting associate professorship in the Department of History at Temple University.

VICTORIA E. URIS, Associate Professor, Department of Dance, effective Autumn Quarter 2002, Winter Quarter and Spring Quarter 2003, for personal reasons.

GEORGE A. ALESSANDRIA, Assistant Professor, Department of Economics, effective Autumn Quarter 2002, Winter Quarter and Spring Quarter 2003, to accept a visiting assistant professorship in the Economics Department of the Leonard Stern School of Business at New York University.

ANDREW T. CHING, Assistant Professor, Department of Economics, effective Autumn Quarter 2002, Winter Quarter and Spring Quarter 2003, to accept a visiting assistant professorship in the Economics Department at UCLA.

TIMOTHY M. FRYE, Assistant Professor, Department of Political Science, effective Autumn Quarter 2002, Winter Quarter and Spring Quarter 2003, for personal reasons.

KIRA SANBONMATSU, Assistant Professor, Department of Political Science, effective Autumn Quarter 2002, Winter Quarter and Spring Quarter 2003, to accept a visiting professorship at the Center for American Women and Politics at the Eagleton Institute of Politics, The State University of New Jersey–Rutgers.

Leave of Absence Without Salary—Continuation

LEIGH GILMORE, Associate Professor, Department of English, effective Autumn Quarter 2002, Winter Quarter and Spring Quarter 2003, to continue her appointment as Resident Scholar at the Center for Cultural Studies at the University of California, Santa Cruz.

Professional Improvement Leaves

GREGORY A. CALDEIRA, Distinguished University Professor, Department of Political Science, effective Spring Quarter 2003.

J. CRAIG JENKINS, Professor, Department of Sociology, effective Autumn Quarter 2002 and Winter Quarter 2003.

SYED M. TARIQ RIZVI, Professor, Department of Mathematics (Lima Campus), effective Winter Quarter and Spring Quarter 2003.

Professional Improvement Leaves -- Cancellation

ROBERT C. MACCALLUM, Professor, Department of Psychology, effective Autumn Quarter 2002, Winter Quarter and Spring Quarter 2003.

STEVEN CONN, Associate Professor, Department of History, effective Autumn Quarter 2002, Winter Quarter and Spring Quarter 2003.

PERSONNEL ACTIONS (contd)

Emeritus Titles

HARISIOS BOUDOULAS, Department of Internal Medicine, with the title Professor Emeritus, effective September 1, 2002.

STEPHEN A. BUSER, Department of Finance, with the title Professor Emeritus, effective September 1, 2002.

WALTER D. BURNSIDE, Department of Electrical Engineering, with the title Professor Emeritus, effective September 1, 2002.

THORWALD HERBERT, Department of Mechanical Engineering, with the title Professor Emeritus, effective September 1, 2002.

VERNON C. STEVENS, Department of Obstetrics and Gynecology, with the title Professor Emeritus, effective September 1, 2002.

W. BRUCE WALSH, Department of Psychology, with the title Professor Emeritus, effective September 1, 2002.

JOHN L. ROBINSON, Department of Internal Medicine, with the title Associate Professor Emeritus, effective September 1, 2002.

RICHARD K. RUSSELL, Department of Psychology, with the title Associate Professor Emeritus, effective September 1, 2002

DAVID A. JONES, Ohio State University Extension, with the title Assistant Professor Emeritus, effective September 1, 2002.

CAROLYN B. MCKINNEY, Department of Consumer and Textile Sciences, with the title Assistant Professor Emeritus, effective September 1, 2002.

JOYCE A. SMITH, Department of Consumer and Textile Sciences, with the title Assistant Professor Emeritus, effective September 1, 2002.

Promotions, Tenure, and Reappointments

MAX FISHER COLLEGE OF BUSINESS

PROMOTION TO ASSOCIATE PROFESSOR WITH TENURE

Neelima M. Bendapudi, Marketing & Logistics - effective 10/1/2002

[corrections of Tenure Initiating Units]

COLLEGE OF EDUCATION

PROMOTION TO PROFESSOR

Donna L. Pastore, School of Physical Activity & Educational Services - effective 10/1/2002

PROMOTION TO ASSOCIATE PROFESSOR WITH TENURE

Janet Buckworth, School of Physical Activity & Educational Services - effective 10/1/2002

Nancy A. Neef, School of Physical Activity & Educational Services - effective 10/1/2002

Phillip C. Ward, School of Physical Activity & Educational Services - effective 10/1/2002

PERSONNEL ACTIONS (contd)

Promotions, Tenure, and Reappointments (contd)

[corrections of Tenure Initiating Units] (contd)

COLLEGE OF MEDICINE & PUBLIC HEALTH

PROMOTION TO PROFESSOR

James W. Hoekstra, Emergency Medicine - effective 7/1/2002

Medical Staff Appointments/Reappointments (The Arthur G. James Cancer Hospital and Richard J. Solove Research Institute)

June/July 2002

Initial Appointments – Faculty

Talal Attar, M.D., Internal Medicine, Cardiology, Clinical Assistant Professor, Associate Attending
Udayan Y. Bhatt, M.D., Internal Medicine, Nephrology, Assistant Professor, Associate Attending
Philip E. Calendine, M.D., Radiology, Clinical Assistant Professor, Associate Attending
Dongwoo Chang, M.D., Surgery, Neurosurgery, Assistant Professor, Associate Attending
Arun Gowdamarasan, M.D., Surgery, General Surgery, Clinical Assistant Professor, Associate Attending
William J. Hicks, M.D., Internal Medicine, Hematology/Oncology, Professor of Clinical Medicine, Attending
Richard P. Lewis, M.D., Internal Medicine, Cardiology, Emeritus Professor of Medicine, Associate Attending
Gwyn R. Londeree, M.D., Internal Medicine, Dermatology, Assistant Associate Professor, Clinical Attending
Gerard Lozanski, M.D., Pathology, Assistant Professor, Associate Attending
Marybeth Luca, D.O., Internal Medicine, Dermatology, Clinical Assistant Professor, Associate Attending
Douglas D. Massick, M.D., Otolaryngology, Clinical Assistant Professor, Associate Attending
Virginia McGrath, M.D., Surgery, General Surgery, Clinical Assistant Professor, Associate Attending
J. Paul Monk III, M.D., Internal Medicine, Hematology/Oncology, Clinical Assistant Professor, Attending
Kenneth Morgenstern, M.D., Ophthalmology, Clinical Attending
Carl D. Morrison III, M.D., D.V.M., Pathology, Assistant Professor, Clinical Research, Associate Attending
Subha J. Raman, M.D., Internal Medicine, Cardiology, Assistant Professor, Associate Attending
Kottil W. Rammohan, M.D., Neurology, Associate Professor, Associate Attending
Jason G. Sayat, M.D., Obstetrics and Gynecology, Assistant Professor, Clinical Attending
John R. Schwarzell, M.D., Surgery, General Surgery, Associate Attending
Joel A. Shockley, M.D., Radiology, Clinical Assistant Professor, Associate Attending
Meade C. van Putten, Jr., D.D.S., M.S. Dentistry (Did not apply for reappointment this year, but meant to do so.)
Ping Wen, M.D., Ph.D., Pathology, Associate Attending
Joseph Zaki, M.D., Anesthesiology, Clinical Assistant Professor, Associate Attending
Kelly J. Zyniewicz, M.D., Internal Medicine, Dermatology, Clinical Assistant Professor, Clinical Attending

Initial Appointments – Community

Kumar Murkerjee, M.D., Gastroenterology (Was not reappointed due to lack of CME documentation; Eligible for a one-year appointment)
Marios Panayides, M.D., Surgery (Was not reappointed due to lack of CME documentation; Eligible for a one-year appointment)

PERSONNEL ACTIONS (contd)

Medical Staff Appointments/Reappointments (The Arthur G. James Cancer Hospital and Richard J. Solove Research Institute) (contd)

June/July 2002 (contd)

Initial Appointments – Community (contd)

- Steven Patterson, D.O., Obstetrics and Gynecology (Was not reappointed due to lack of CME documentation; Eligible for two-year appointment)
Ferdinand Santos, M.D., Anesthesiology (Was not reappointed due to lack of CME documentation; Eligible for a one-year appointment)
Rama Selvarajah, M.D., Family Practice (Was not reappointed due to lack of CME documentation; Eligible for a one-year appointment)
Dennis Sullivan, M.D., Neurology (Was not reappointed due to lack of CME documentation; Eligible for a one year appointment)
Khariat Ahmed Uddin, M.D., General Medicine (Was not reappointed due to lack of CME documentation; Eligible for a one year appointment)
William Vazquez-Choisne, M.D., Radiology (Was not reappointed due to lack of CME documentation; Eligible for two-year appointment)

Reappointment – Faculty, 7/1/02 – 6/30/04

- Raymond D. Magorien, M.D., James Internal Medicine, James Associate Attending
Cynthia M. Magro, M.D., James Pathology, James Associate Attending
William E. Maher, M.D., James Internal Medicine, James Associate Attending
William B. Malarkey, M.D., James Internal Medicine, James Associate Attending
Susan R. Mallery, D.D.S., Ph.D., James Dentistry, James Associate Attending
Julie E. Mangino, M.D., James Internal Medicine, James Associate Attending
Tasos Manokas, D.O., James Internal Medicine, James Associate Attending
Unni K. Marar, M.D., James Internal Medicine, James Associate Attending
Guido Marcucci, M.D., James Internal Medicine, James Attending
Clay B. Marsh, M.D., James Internal Medicine, James Associate Attending
William L. Marsh, Jr., M.D., James Pathology, James Associate Attending
Larry C. Martin, M.D., James Surgery, James Associate Attending
Thomas F. Mauger, M.D., James Ophthalmology, James Associate Attending
Joel L. Mayerson, M.D., James Orthopaedics, James Attending
John M. McGregor, M.D., James Surgery, James Associate Attending
Mitchell A. Medow, M.D., James Internal Medicine, James Associate Attending
Hagop S. Mekhjian, M.D., James Internal Medicine, James Associate Attending
W. Scott Melvin, M.D., James Surgery, James Associate Attending
Jerry R. Mendell, M.D., James Neurology, James Associate Attending
Robert E. Michler, M.D., James Surgery, James Associate Attending
Robert J. Miller, D.O., James Anesthesiology, James Associate Attending
Michael E. Miner, M.D., James Surgery, James Associate Attending
William F. Miser, M.D., James Family Medicine, James Associate Attending
Omar Mobin-Uddin, M.D., James Ophthalmology, James Associate Attending
Yousef M. Mohammad, M.D., James Neurology, James Associate Attending
Arthur Molina, M.D., James Internal Medicine, James Attending
James L. Moore, M.D., James Neurology, James Associate Attending
Robert A. Murden, M.D., James Internal Medicine, James Associate Attending
Peter Muscarella, II, M.D., James Surgery, James Associate Attending
Subir Nag, M.D., James Radiology, James Attending
Norris S. Nahman, Jr., M.D., James Internal Medicine, James Associate Attending
Nestor M. Narcelles, M.D., James Anesthesiology, James Associate Attending
Steven M. Nash, M.D., James Neurology, James Associate Attending
Bradley J. Needleman, M.D., James Surgery, James Associate Attending
Anterpreet S. Neki, M.D., James Internal Medicine, James Attending
Richard N. Nelson, M.D., James Emergency Medicine, James Associate Attending

PERSONNEL ACTIONS (contd)

Medical Staff Appointments/Reappointments (The Arthur G. James Cancer Hospital and Richard J. Solove Research Institute) (contd)

June/July 2002 (contd)

Reappointment – Faculty, 7/1/02 – 6/30/04 (contd)

Steven D. Nelson, M.D., James Internal Medicine, James Associate Attending
Gregory M. Ness, D.D.S., James Dentistry, James Associate Attending
Herbert B. Newton, M.D., James Neurology, James Attending
Jose J. Norberto, M.D., James Surgery, James Associate Attending
Gerard J. Nuovo, M.D., James Pathology, James Associate Attending
Margaret A. Nuovo, M.D., James Pathology, James Clinical Attending
Richard W. O'Shaughnessy, M.D., James OB/GYN, James Associate Attending
Robert V. O'Toole, M.D., James Pathology, James Associate Attending
Johannes O. Olsen, M.D., James Radiology, James Associate Attending
David A. Orsinelli, M.D., James Internal Medicine, James Associate Attending
Kwame Osei, M.D., James Internal Medicine, James Associate Attending
Gregory A. Otterson, M.D., James Internal Medicine, James Attending
Michael F. Para, M.D., James Internal Medicine, James Associate Attending
George W. Paulson, M.D., James Neurology, James Associate Attending
Ronald P. Pelletier, M.D., James Surgery, James Associate Attending
Sam L. Penza, M.D., James Internal Medicine, James Attending
Todd E. Pesavento, M.D., James Internal Medicine, James Associate Attending
Sheryl A. Pfeil, M.D., James Internal Medicine, James Associate Attending
Amy L. Pope-Harman, M.D., James Internal Medicine, James Associate Attending
Pierluigi Porcu, M.D., James Internal Medicine, James Attending
Stephen P. Pivoski, M.D., James Surgery, James Attending
David M. Powell, M.D., James Otolaryngology, James Associate Attending
Rodney V. Pozderac, M.D., James Radiology, James Associate Attending
Manju L. Prasad, M.D., James Pathology, James Associate Attending
Daniela M. Proca, M.D., James Pathology, James Associate Attending
Amer Rajab, M.D., Ph.D., James Surgery, James Associate Attending
Niisa D. Ramirez Milan, M.D., James Pathology, James Associate Attending
Gary L. Rea, M.D., James Surgery, James Associate Attending
Thomas E. Reilley, D.O., James Anesthesiology, James Associate Attending
Chris A. Rhoades, M.D., James Internal Medicine, James Attending
Stephen R. Richards, M.D., James OB/GYN, James Clinical Attending
John L. Robinson, M.D., James Internal Medicine, James Associate Attending
Patrick Ross, Jr., M.D., Ph.D., James Surgery, James Attending
Brad H. Rovin, M.D., James Internal Medicine, James Associate Attending
Robert L. Ruberg, M.D., James Surgery, James Associate Attending
James M. Ryan, M.D., James Internal Medicine, James Associate Attending
Zarife Sahenk, M.D., James Neurology, James Associate Attending
Mervyn J. Samuel, M.D., James OB/GYN, James Clinical Attending
Philip Samuels, M.D., James OB/GYN, James Associate Attending
George A. Sawaya, M.D., James OB/GYN, James Clinical Attending
Stephen F. Schaal, M.D., James Internal Medicine, James Associate Attending
Jonathan A. Schaffir, M.D., James OB/GYN, James Associate Attending
Douglas W. Scharre, M.D., James Neurology, James Associate Attending
David E. Schuller, M.D., James Otolaryngology, James Attending
Dara P. Schuster, M.D., James Internal Medicine, James Associate Attending
Daniel D. Sedmak, M.D., James Pathology, James Associate Attending
Manisha H. Shah, M.D., James Internal Medicine, James Attending
Niranjan T. Shah, M.D., James Pathology, James Associate Attending
Arwa Y. Shanaah, M.D., James Pathology, James Associate Attending
Charles L. Shapiro, M.D., James Internal Medicine, James Attending
Cynthia S. Shellhaas, M.D., James OB/GYN, James Associate Attending

PERSONNEL ACTIONS (contd)

Medical Staff Appointments/Reappointments (The Arthur G. James Cancer Hospital and Richard J. Solove Research Institute) (contd)

June/July 2002 (contd)

Reappointment – Faculty, 7/1/02 – 6/30/04 (contd)

Phillip J. Shubert, M.D., James OB/GYN, James Associate Attending
Robert T. Sickles, M.D., James Family Medicine, James Associate Attending
Ronald J. Siegle, M.D., James Otolaryngology, James Clinical Attending
Daniel S. Sinclair, M.D., James Radiology, James Associate Attending
Andrew P. Slivka, Jr, M.D., James Neurology, James Associate Attending
Robert H. Small, M.D., James Anesthesiology, James Associate Attending
William L. Smead, M.D., James Surgery, James Associate Attending
Namita Sood, M.D., James Internal Medicine, James Associate Attending
Gaylynn J. Speas, M.D., James Anesthesiology, James Associate Attending
Carl E. Speicher, M.D., James Pathology, James Associate Attending
Dan N. Spetie, M.D., James Internal Medicine, James Associate Attending
Dimitrios G. Spigos, M.D., James Radiology, James Associate Attending
Steven M. Steinberg, M.D., James Surgery, James Associate Attending
Saul M. Suster, M.D., James Pathology, James Associate Attending
Joseph F. Swan, M.D., James Anesthesiology, James Associate Attending
Larry R. Tate, M.D., James Pathology, James Associate Attending
Steven Teich, M.D., James Surgery, James Clinical Attending
Victor D. Terebuh, M.D., James Anesthesiology, James Associate Attending
Andrew M. Thomas, M.D., James Internal Medicine, James Associate Attending
Fred B. Thomas, M.D., James Internal Medicine, James Associate Attending
James C. Tober, M.D., James Surgery, James Associate Attending
Evan J. Tobin, M.D., James Otolaryngology, James Associate Attending
Marlin F. Troiano, D.D.S., James Dentistry, James Associate Attending
Katja R. Turner, M.D., James Anesthesiology, James Associate Attending
Adam C. Tzagournis, M.D., James Internal Medicine, James Associate Attending
Manuel Tzagournis, M.D., James Internal Medicine, James Associate Attending
Geoffrey C. Vaughan, M.D., James Internal Medicine, James Associate Attending
Rafael E. Villalobos, D.O., James Surgery, James Clinical Attending
Miguel A. Villalona-Calero, M.D., James Internal Medicine, James Attending
Paul E. Wakely, Jr., M.D., James Pathology, James Associate Attending
Michael J. Walker, M.D., James Surgery, James Attending
Joel M. Weaver, D.D.S., Ph.D., James Dentistry, James Associate Attending
Paul A. Weber, M.D., James Ophthalmology, James Associate Attending
Alvin G. Wee, D.D.S., James Dentistry, James Associate Attending
Harrison G. Weed, M.D., James Internal Medicine, James Associate Attending
Jeffrey E. Weiland, M.D., James Internal Medicine, James Associate Attending
MaryJo P. Welker, M.D., James Family Medicine, James Associate Attending
D. Bradley Welling, M.D., James Otolaryngology, James Associate Attending
Howard A. Werman, M.D., James Emergency Medicine, James Associate Attending
Judith A. Westman, M.D., James Internal Medicine, James Associate Attending
Mark D. Wewers, M.D., James Internal Medicine, James Associate Attending
Ronald L. Whisler, M.D., James Internal Medicine, James Associate Attending
Gregory J. Wiet, M.D., James Otolaryngology, James Associate Attending
William A. Wilmer, M.D., James Internal Medicine, James Associate Attending
David A. Wininger, M.D., James Internal Medicine, James Associate Attending
John H. Winston, III, M.D., James Surgery, James Associate Attending
Randall K. Wolf, M.D., James Surgery, James Associate Attending
Haifeng M. Wu, M.D., James Pathology, James Associate Attending
Yun Xia, M.D., James Anesthesiology, James Associate Attending
David O. Yablok, M.D., James Anesthesiology, James Associate Attending
Allan J. Yates, M.D., Ph.D., James Pathology, James Associate Attending

PERSONNEL ACTIONS (contd)

Medical Staff Appointments/Reappointments (The Arthur G. James Cancer Hospital and Richard J. Solove Research Institute) (contd)

June/July 2002 (contd)

Reappointment – Faculty, 7/1/02 – 6/30/04 (contd)

Lisa D. Yee, M.D., James Surgery, James Attending
Pan Zheng, M.D., Ph.D., James Pathology, James Associate Attending
Discussion Case: Physician #846549
Reappointment approved contingent upon physician responding to Credentials Comm. request

Reappointment – Community, 7/1/02 – 6/30/04

Elizabeth M. Marsh, M.D., James Internal Medicine, James Community Associate
Michael S. McKee, M.D., James Family Medicine, James Community Associate
Carolyn P. Misick, M.D., James Pathology, James Community Associate
Lofton N. Misick, M.D., James Surgery, James Community Associate
David G. Monjot, M.D., James Internal Medicine, James Community Associate
Joseph M. Morman, M.D., James Family Medicine, James Community Associate
Timothy A. Morton, M.D., James Emergency Medicine, James Community Associate
Annette R. Nathan, M.D., James Emergency Medicine, James Community Associate
Richard M. Nedelman, M.D., James Surgery, James Community Associate
Surender R. Neravetla, M.D., James Surgery, James Community Associate
Charles D. Parsons, M.D., James Surgery, James Community Associate
Ganesh G. Potdar, M.D., James Radiology, James Community Oncologist
Richard D. Potts, M.D., James Family Medicine, James Community Associate
Thomas P. Rak, M.D., James Surgery, James Community Associate
Moin A. Ranginwala, M.D., James Internal Medicine, James Community Associate
Abdur Rauf, M.D., James Internal Medicine, James Community Associate
Janet M. Roberto, M.D., James Family Medicine, James Community Associate
Mark S. Roberto, M.D., James Family Medicine, James Community Associate
Robert D. Rupert, Jr., M.D., James Internal Medicine, James Community Oncologist
Kira Schofield, M.D., James Surgery, James Community Associate
Robert J. Scott, M.D., James Internal Medicine, James Community Associate
Jerry K. Shell, M.D., James Ophthalmology, James Community Associate
Daljeet Singh, M.D., James Internal Medicine, James Community Oncologist
Ranjit R. Singh, M.D., James Surgery, James Community Associate
Risa L. Spiello, M.D., James Family Medicine, James Community Associate
Ronald B. Spier, M.D., James Surgery, James Community Associate
Toni Sublett, M.D., James Internal Medicine, Community Associate
Ajaz Umerani, M.D., James Internal Medicine, James Community Associate
George Varghese, M.D., James Internal Medicine, James Community Associate
Siva R. Vemana, M.D., James Internal Medicine, James Community Associate
Peter W. Wagner, M.D., James Surgery, James Community Associate
Jeffrey W. Weinstein, M.D., James Internal Medicine, James Community Associate
Thomas J. Williams, M.D., James Emergency Medicine, James Community Associate
Peter B. Wittstein, M.D., James Ophthalmology, James Community Associate
Howard F. Wunderlich, III, M.D., James Internal Medicine, James Community Associate
Talal R. Zraik, M.D., James Internal Medicine, James Community Associate

Provisional to Full Appointment

Arthur Bertolino, M.D., Internal Medicine, Dermatology, Associate Attending
Nitin Bhatt, M.D., Internal Medicine, Pulmonary, Associate Attending
Joel Mayerson, M.D., Orthopaedic Oncology, Attending
Amer Rajab, M.D. Surgery, Transplant, Associate Attending

PERSONNEL ACTIONS (contd)

Medical Staff Appointments/Reappointments (The Arthur G. James Cancer Hospital and Richard J. Solove Research Institute) (contd)

June/July 2002 (contd)

Provisional to Full Appointment (contd)

Abhik Ray-Chaudhury, M.D., Pathology, Associate Attending
Namita Sood, M.D., Internal Medicine, Pulmonary, Associate Attending
Thomas Yunger, M.D., Internal Medicine, Pulmonary, Associate Attending

Provisional to Full Appointment – Allied Health Practitioners

Julia Garrett, C.N.P., Hematology/Oncology
Marcia Starns, P.A., Cardiothoracic Surgery

Additional Privileges Requested

Maureen Buckner, C.N.P., Lumbar Puncture and Intrathecal Chemotherapy Administration,
Ommaya Reservoir, Tap and Chemo Injection
Tracy Hollar-Reugg, C.N.P., Paracentesis, Lumbar Puncture, Intrathecal Chemotherapy
Administration, Thoracentesis, Ommaya Reservoir, Tap and Chemo Injection

Conscious Sedation

James Allen, M.D., Moderate and Deep sedation
Mark Arnold, M.D., Moderate sedation
Chris Ellison, M.D., Moderate sedation
Charles Love, M.D., Moderate and Deep sedation
W. Scott Melvin, M.D., Moderate sedation
Peter Muscarella, M.D., Moderate sedation
Steven Steinberg, M.D., Moderate and Deep sedation
Michael Walker, M.D., Moderate sedation
John Winston, M.D., Moderate sedation

Change in Medical Staff Category

Ahmed Ghany change from the Community Oncologist Attending category to the Clinical Attending category with his recent medical staff appointments at University Hospitals, which reflect his part-time faculty status.
Robert Rupert change from the Community Oncologist Attending category to the Clinical Attending category with his recent medical staff appointments at University Hospitals, which reflect his part-time faculty status.

RESOLUTIONS IN MEMORIAM

Resolution No. 2003-29

Synopsis: Approval of Resolutions in Memoriam is proposed.

RESOLVED, That the Board adopt the following Resolutions in Memoriam and that the President be requested to convey a copy to the families of the deceased.

RESOLUTIONS IN MEMORIAM (contd)

William E. Copeland, Jr.

The Board of Trustees of The Ohio State University expresses its sorrow upon the death on May 30, 2002, of Dr. William E. Copeland, Jr., Clinical Professor in the College of Medicine and Public Health.

William E. Copeland was born August 3, 1949, to William and Carolyn Copeland in Philadelphia, Pennsylvania. He attended Upper Arlington High School, graduating in the Class of 1967. He received his B.A. degree from Ohio Wesleyan University in 1971 and his M.D. degree from The Ohio State University College of Medicine in 1974. After completing two years of general surgery at Moffitt Hospital, he completed his residency training in obstetrics and gynecology at The Ohio State University in 1980.

Dr. Copeland practiced medicine with his father and brother, Christopher, for 22 years at Kingsdale Gynecologic Associates, a group practice founded by his father, William E. Copeland, Sr. His professional affiliations included the Central Association of Obstetricians and Gynecologists, fellow of the American College of Obstetricians and Gynecologists, North American Obstetrical and Gynecologic Society, Alpha Omega Alpha (medical honorary), Columbus Medical Review Club, and numerous other medical organizations. He received the Compassionate Physician Award from Riverside Hospital in 2001. He was a highly-esteemed clinician and excellent teacher who will be missed by all.

On behalf of the University community, the Board of Trustees expresses to the family of Dr. William Copeland, Jr., its deepest sympathy and sense of understanding of their loss. It was directed that this resolution be inscribed upon the minutes of the Board of Trustees and that a copy be tendered to his family as an expression of the Board's heartfelt sympathy.

Frank W. Fisk

The Board of Trustees of The Ohio State University expresses its sorrow upon the death on July 31, 2002, of Frank W. Fisk, Professor Emeritus in the Department of Entomology.

Professor Fisk held a Bachelor of Science degree from the University of Illinois, and Master of Science and Doctor of Philosophy degrees from the University of Minnesota. He was appointed an assistant professor in the Department of Zoology and Entomology at The Ohio State University in 1949. His research specialty was in the area of insect physiology, with a primary interest in the digestive enzymes of insects. In addition, he worked on the chemical aspects of insect-plant interactions and the physiological aspects of cockroach behavior and taxonomy. Until his retirement in 1975, Professor Fisk annually taught a course in insect physiology. Additional teaching assignments from time to time included courses in insect toxicology, internal morphology, and research methods.

His graduate studies were interrupted by World War II, and during this time he joined the U.S. Public Health Service. He was sent overseas in 1941 as a commissioned officer with the Yunnan-Burma Railway Medical Mission and then with the U.S. Army Surgeon General. Professor Fisk served as an associate entomologist in the U.S. Public Health Service at the Communicable Disease Center until 1946, and afterwards served in the U.S.P.H.S. Reserve Corp for many years.

Professor Fisk's interests in tropical and subtropical cockroaches resulted in many field expeditions to the desert southwest in the U.S., Mexico, Costa Rica, Panama, and other regions of Central America. This work resulted in the discovery of several new species of cockroaches, and many of his retirement years were filled with research on the tropical cockroach fauna.

Professor Fisk was an active member of the Entomological Society of America, the American Institute of Biological Sciences, Phi Beta Kappa, Sigma Xi, and Gamma Sigma Delta; and was a fellow of the Ohio Academy of Science.

RESOLUTIONS IN MEMORIAM (contd)

Frank W. Fisk (contd)

He was known as a gentleman of subtle wit and gentle humor. His former graduate students and faculty colleagues appreciated his support, guidance, and the good relationships that he fostered within the department.

On behalf of the University community, the Board of Trustees expresses to the family of Professor Frank W. Fisk its deepest sympathy and sense of understanding of their loss. It was directed that this resolution be inscribed upon the minutes of the Board of Trustees and that a copy be tendered to his family as an expression of the Board's heartfelt sympathy.

Eric S. Fredin

The Board of Trustees of The Ohio State University expresses its sorrow upon the death on July 30, 2002, of Eric S. Fredin, Associate Professor in the School of Journalism and Communication.

Professor Fredin held a Bachelor's degree from Oberlin College, where he majored in English and pursued concentrations in music and philosophy. After a five-year stint as a working reporter, Professor Fredin earned a doctorate in mass communications from the University of Michigan. For seven years he served as an instructor and assistant professor of journalism at Indiana University and then moved to Ohio State in 1985. In his 17 years of service to Ohio State, Professor Fredin taught a wide variety of courses, most with a central focus on the role of the media in society.

Professor Fredin was widely recognized by colleagues and students as a highly involved and caring teacher. He was especially concerned that journalism be taught critically and intellectually. This teaching emphasis formed a synergistic relationship with Professor Fredin's scholarship which emphasized how communication in general and media in particular serve democracy for better or for worse.

Professor Fredin was actively involved in governance within his school, serving actively over the years on promotion and tenure, graduate studies, and research committees. He was also an active author and reviewer for the academic journals in mass communication studies.

On behalf of the University community, the Board of Trustees expresses to the family of Eric S. Fredin its deepest sympathy and sense of understanding of their loss. It was directed that this resolution be inscribed upon the minutes of the Board of Trustees and that a copy be tendered to his family as an expression of the Board's heartfelt sympathy.

Nicholas Holowaychuk

The Board of Trustees of The Ohio State University expresses its sorrow upon the death on April 16, 2002, of Nicholas Holowaychuk, Professor Emeritus in the Department of Horticulture and Crop Science (formerly the Department of Agronomy).

Professor Holowaychuk held Bachelor of Science and Master of Science degrees from the University of Alberta, Canada. He received his Ph.D. degree from The Ohio State University in 1950 and was appointed assistant professor that same year. He served the Department of Agronomy for 28 years, retiring as professor in 1978. His teaching and scholarship interests focused on the genesis and classification of soils as well as their distribution and wise use.

Prior to his appointment to the faculty of The Ohio State University, Dr. Holowaychuk had been employed as a soil scientist with the U.S. Department of Agriculture. In that position he worked in several Great Plains and New England states. During World War II he served with the U.S. Army Air Force as a weather forecaster and received the Bronze Star for service in the Middle East.

RESOLUTIONS IN MEMORIAM (contd)

Nicholas Holowaychuk (contd)

During his tenure, his expertise was sought by many in various parts of the United States and in foreign countries. Dr. Holowaychuk was instrumental in the formation of cooperative arrangements between university, state, and federal organizations to promote the wise use of the soil as an invaluable natural resource. He helped found and served as chairman of Ohio's Soil Inventory Board. His interest in soils of cold regions led to his helping to organize the Byrd Polar Research Center at OSU. In 1968-69 he traveled to India and Brazil as a consultant to the Ohio State-USAID programs in those countries. Other assignments included Alaska, Greenland, and the Belgian Congo.

Professor Holowaychuk served his profession as a teacher and researcher at the local, national, and international levels. He was a long-term member of the Soil Science Society of America and the International Soil Science Society. In 1958 he was honored as a Fellow in the American Association for the Advancement of Science and in 1963 was named Fellow in the Ohio Academy of Science.

On behalf of the University community, The Board of Trustees expresses to the family of Professor Nicholas Holowaychuk its deepest sympathy and sense of understanding of their loss. It was directed that this resolution be inscribed upon the minutes of the Board of Trustees and that a copy be tendered to his family as an expression of the Board's heartfelt sympathy.

George E. MacWood

The Board of Trustees of The Ohio State University expresses its sorrow upon the death on July 11, 2002, of George E. MacWood, Associate Professor Emeritus in the Department of Chemistry.

Professor MacWood held an A.B. degree from Columbia College, B.S. and Ch.E. degrees from the Columbia Engineering School, and a Ph.D. degree from Columbia University where he was also an instructor. He was a recipient of a National Science Foundation fellowship for post-doctoral work at the University of Leiden before 1938, after which time he joined The Ohio State University. During the period from 1943 to 1946, he served on the Manhattan Project as an assistant director of the Lawrence Livermore Radiation Laboratory in Berkeley. After World War II, he returned to Ohio State as an associate professor of chemistry and remained a faculty member until his retirement in 1977.

Professor MacWood was a sound teacher of great versatility. He taught freshman chemistry as well as most of the physical chemistry offerings of the department at some time during his career. He was a superb teacher of thermodynamics at the highest level. He chaired many seminars covering topics in quantum mechanics, non-uniform gas theory, and solid state chemistry.

George MacWood's research covered a considerable range of subjects. With Professor Harold C. Urey he determined the Raman spectra of deuterium and its compounds with hydrogen. This work in part gained the Nobel Prize for Dr. Urey. At Leiden, Professor MacWood determined the viscosity of helium at the time that superfluid helium was discovered. He noted that superfluid helium slipped over a solid surface, the only known liquid displaying this property.

At The Ohio State University, his work covered a wide variety of subjects, i.e. (1) sublimation rates of solids, (2) the thermodynamics of titanium halides, (3) temperature-entropy diagram for diborane, (4) the heat of conversion of para-hydrogen to equilibrium hydrogen below 20° K, and (5) the determination of virial coefficients for a variety of halo-methanes which finds application in refrigeration engineering.

Professor MacWood was an active member of the University community. He served on many doctoral examination committees. He served as assistant director of the Research Foundation of The Ohio State University from 1954-1961. In short, George MacWood was a vastly knowledgeable professor of wide experience.

RESOLUTIONS IN MEMORIAM (contd)

George E. MacWood (contd)

On behalf of the University community, the Board of Trustees expresses to the family of George E. MacWood its deepest sympathy and sense of understanding of their loss. It was directed that this resolution be inscribed upon the minutes of the Board of Trustees and that a copy be tendered to his family as an expression of the Board's heartfelt sympathy.

Stuart Lee Petrie

The Board of Trustees of The Ohio State University expresses its sorrow upon the death on December 31, 2001, of Stuart Lee Petrie, Professor Emeritus in the Department of Aerospace Engineering and Aviation.

Professor Petrie entered the Aeronautical Engineering Program as a freshman in 1954 and embarked on a 32-year career of excellence in teaching, research, service, and administration at OSU. Joining the department's Aerodynamic Research Laboratory as a research associate after graduation with his bachelor's degree, he focused on hypersonic aerodynamics as a newly emerging research activity. He rapidly attained national recognition for his development of diagnostic instrumentation for high temperature airflows, using electron beam and spectroscopy to make non-intrusive measurements in hypersonic plasmas.

Stuart Petrie received his doctorate in 1964 and joined the teaching faculty of the newly named Department of Aeronautical and Astronautical Engineering. Teaching classes in advanced aerodynamics, he again excelled by putting his students at ease by his classroom demeanor, eliciting questions, and clarifying complex high temperature phenomena. Professor Petrie brought his research into the classroom. His classes were always lively with discussion and were a breeding ground for innovative ideas. His students showed their appreciation by selecting Professor Petrie for one the first MacQuigg Awards. The MacQuigg is a College of Engineering award for teaching excellence as determined by the engineering college students.

Professor Petrie was selected as the second chairperson of the Department of Aeronautical and Astronautical Engineering, upon the retirement of Chairperson Garvin Von Eschen (1946 – 1979), and continued in that role until his own retirement from the University in 1986. Professor Petrie was sought after as a consultant to industry and government, and served on many national committees for DoD, NASA, USAF, and others involved in aerodynamic research. He was especially influential in the operations of the Supersonic Wind Tunnel Association. This unique organization of specialists in experimental research is composed of research leaders from academia, government, and industry who guide much of the nation's aerodynamic research programs. Professor Petrie had several leadership roles in the STA and was honored by the organization for his exceptional service.

After retirement, Professor Petrie continued to serve the aerospace community by directing his technical expertise in supporting the operations of the NASA Lewis Research Center as vice president of Sverdrup Technologies. However, OSU was never far from his heart – he continued to serve as a member of the Department of Aeronautical and Astronautical Engineering's advisory board and was always available to the faculty, and helped in recruiting and research activities.

On behalf of the University community, the Board of Trustees expresses to the family of Professor Stuart Lee Petrie its deepest sympathy and sense of understanding of their loss. It was directed that this resolution be inscribed upon the minutes of the Board of Trustees and that a copy be tendered to his family as an expression of the Board's heartfelt sympathy.

RESOLUTIONS IN MEMORIAM (contd)

Walter C. Rothenbuhler

The Board of Trustees of The Ohio State University expresses its sorrow upon the death on August 14, 2002, of Walter C. Rothenbuhler, Professor Emeritus in the Department of Entomology.

Professor Rothenbuhler held Bachelor of Science, Master of Science, and Doctor of Philosophy degrees from Iowa State University. He was appointed an assistant professor at Iowa State University in 1954 and then joined the faculty of The Ohio State University in 1962. He was widely recognized as the leading researcher in the area of honey bee genetics and, in fact, his research had a major impact in the field of behavior and genetics. His work on honey bees was the first to establish a genetic basis for behavior, and his seminal work in this field in the 1960s is rightly considered to have laid the foundation for the current discipline of behavioral genetics. In addition, his work resulted in the development of effective breeding techniques for the management of disease resistance in honey bees.

He was an outstanding teacher and taught popular courses at The Ohio State University in animal behavior, behavioral genetics, and honey bee biology. He mentored 44 graduate students, many of whom are currently leading U.S. researchers in the field of honey bee biology. Professor Rothenbuhler retired from the University in 1985, but continued to maintain close contact with his former associates as long as his health permitted. As a tribute to his many contributions to the field of honey bee biology, the University named the Rothenbuhler Honey Bee Research Laboratory in his honor in 1989.

Professor Rothenbuhler served his profession at the highest level. He was elected an AAAS Fellow, he was an active member of several professional societies, and he served on the National Research Council Committee on the African Bee. He was a dedicated faculty member who was much appreciated by his students and faculty colleagues.

On behalf of the University community, the Board of Trustees expresses to the family of Professor Walter C. Rothenbuhler its deepest sympathy and sense of understanding of their loss. It was directed that this resolution be inscribed upon the minutes of the Board of Trustees and that a copy be tendered to his family as an expression of the Board's heartfelt sympathy.

REPORT OF RESEARCH CONTRACTS AND GRANTS

Resolution No. 2003-30

Synopsis: The reports on research and other sponsored program contracts and grants and the summaries for June and July 2002 are presented for Board acceptance.

WHEREAS monies are solicited and received on behalf of the University from governmental, industrial, and other agencies in support of research, instructional activities, and service; and

WHEREAS such monies are received through The Ohio State University Research Foundation:

NOW THEREFORE

BE IT RESOLVED, That the research agreement between The Ohio State University and The Ohio State University Research Foundation for the contracts and grants reported herein during the months of June and July 2002 be approved.

REPORT ON UNIVERSITY DEVELOPMENT

Resolution No. 2003-31

Synopsis: The report on the receipt of gifts and the summary for June 2002 are presented for Board acceptance.

WHEREAS monies are solicited and received on behalf of the University from alumni, industry, and various individuals in support of research, instructional activities, and service; and

WHEREAS such gifts are received through The Ohio State University Development Fund and The Ohio State University Foundation; and

WHEREAS this report includes the establishment of Ruth Stanton Chair in Veterinary Medicine; and

WHEREAS this report includes the establishment of twenty-four (24) new named endowed funds and the amendment of three (3) named endowed funds:

NOW THEREFORE

BE IT RESOLVED, That the acceptance of the report from The Ohio State University Development Fund and The Ohio State University Foundation during the month of June 2002 be approved.

REPORT ON UNIVERSITY DEVELOPMENT (contd)

TOTAL UNIVERSITY PRIVATE SUPPORT

July through June
2000-2001 Compared to 2001-2002

GIFT RECEIPTS BY DONOR TYPE

	Dollars July through June		
	<u>2000-2001</u>	<u>2001-2002</u>	<u>%Change</u>
Individuals:			
Alumni (Current Giving)	\$62,061,417	\$33,260,106	(46)
Alumni (From Bequests)	<u>7,514,087</u>	<u>5,811,342</u>	(23)
Alumni Total	\$69,575,504	\$39,071,448	(44)
Non-Alumni (Current Giving)	\$24,212,654	\$16,706,727	(31)
Non-Alumni (From Bequests)	<u>10,094,396</u>	<u>3,619,011</u>	(64)
Non-Alumni Total	\$34,307,050	\$20,325,738	(41)
Individual Total	\$103,882,554	\$59,397,186	(43) ^A
Corporations/Corp/Foundations	\$65,393,047	\$68,970,090	5
Private Foundations	\$22,810,760	\$30,227,818	33 ^B
Associations and Other Organizations	<u>\$18,464,494</u>	<u>\$20,897,592</u>	13 ^C
Total	\$210,550,855	\$179,492,686	(15)

NOTES

- A Individual giving is down 43% due to two primary factors: \$30.3 million gift from an alumnus that was received in June, 2001; and significantly less realized expectancies from bequests.
- B Foundation giving at the \$10,000 or more level is up 43% so far this year (\$18.1 million from 187 gifts last year; \$25.8 million from 230 gifts this year).
- C Other organizations and associations have given about \$200,000 more at the \$10,000 or more level so far this year compared with last year.

REPORT ON UNIVERSITY DEVELOPMENT (contd)

TOTAL UNIVERSITY PRIVATE SUPPORT (contd)

July from June
2000-2001 Compared to 2001-2002

GIFT RECEIPTS BY PURPOSE

	Dollars July through June		
	<u>2000-2001</u>	<u>2001-2002</u>	<u>% Change</u>
Gift Receipts to Current Use and Endowment Funds:			
Buildings/Equipment	\$29,828,669	\$26,751,606	(10)
Faculty Support	\$24,228,488	\$12,391,800	(49)
Program Support	\$122,165,717	\$117,916,174	(3)
Student Financial Aid	\$23,533,599	\$12,932,221	(45)
Annual Funds-Colleges/Departments	\$9,006,443	\$8,229,446	(9)
Annual Funds-University	<u>\$1,787,939</u>	<u>\$1,271,439</u>	(29)
Total	\$210,550,855	\$179,492,686	(15)

GIFT ADDITIONS TO ENDOWMENT

Dollars
July through June

<u>2000-2001</u>	<u>2001-2002</u>	<u>% Change</u>
\$61,303,351	\$38,035,369	(38)

REPORT ON UNIVERSITY DEVELOPMENT (contd)

THE OHIO STATE UNIVERSITY DEVELOPMENT FUND

	<u>Previous Gifts</u>	<u>Current Gifts</u>	<u>Total Gifts</u>
<u>Establishment of Named Endowed Funds</u>			
The Novice G. Fawcett Scholarship Fund in Educational Administration (Used to provide support to Ph.D. students in the College of Education studying with the Novice G. Fawcett Chair; provided by gifts from the estate of Novice G. Fawcett)		\$100,000.00	\$100,000.00
The Franz T. Stone Laboratory Research Endowment Fund (Used to support research conducted at the Franz T. Stone Laboratory; provided by gifts from the estate of Katherine D. Stone)		\$38,765.00	\$38,765.00
The Porterfield-Dickens SPA Assistantship Fund (Used to provide support for an assistantship in the College of Education; provided by gifts from faculty, staff and alumni of Student Affairs/Higher Education)		\$34,962.34	\$34,962.34
John L. Crites Fellowship at Stone Laboratory Fund (Used to support research awards for research at Franz T. Stone Laboratory; provided by gifts from alumni and Friends of Stone Laboratory)		\$26,290.00	\$26,290.00
The George A. Krieger University Scholarship Fund (Used to provide Merit Scholarship support at the University Scholarship level; provided by gifts from George A. Krieger and the Krieger family) (grandfathered)		\$15,000.00	\$15,000.00
The Seubert Family Chadwick Arboretum Guest Lecturer Endowment Fund (Used to support a guest lecturer at the Chadwick Arboretum; provided by gifts from Howard P. Seubert, Mariruth Dresbach Seubert, Suzanne Seubert-Rowan, Stuart H. Seubert, and Steven M. Seubert) (grandfathered)		\$5,500.00	\$5,500.00
<u>Change in Description of Named Endowed Fund</u>			
The Helen Strow International Programs Fund in the College of Human Ecology			
<u>Change in Name and Description of Named Endowed Funds</u>			
From: T. Kline Hamilton Award To: T. Kline Hamilton Award Fund			
From: Marion Campus Minority Scholarship Fund To: Larry Prude Memorial Minority Scholarship Fund			

REPORT ON UNIVERSITY DEVELOPMENT (contd)

THE OHIO STATE UNIVERSITY FOUNDATION

	<u>Previous Gifts</u>	<u>Current Gifts</u>	<u>Total Gifts</u>
<u>Establishment of Named Endowed Chair</u>			
Ruth Stanton Chair in Veterinary Medicine (Used to support a chair in the College of Veterinary Medicine; provided by a gift from Frank Stanton)		\$1,504,404.00	\$1,504,404.00
<u>Establishment of Named Endowed Funds</u>			
The Excellence in Radiology Endowment Fund (Used to support priorities in the Department of Radiology in the College of Medicine and Public Health; provided by gifts from corporations, foundations, and individual donors)		\$581,111.02	\$581,111.02
The George A. and Jean M. Madden Parkinson's Disease/Movement Disorders Endowment Fund (Used to support research and education conducted in the "George and Jean Madden – National Parkinson Foundation Parkinson's Disease Center for Excellence"; provided by gifts from the estate of George A. Madden, Jean M. Madden, and the George A. and Jean M. Madden Foundation)	\$504,913.00		\$504,913.00
The Fultz Family Athletic Scholarship Fund (Used to provide scholarship costs of student athletes participating on the varsity football team; provided by gifts from Robert R. Fultz and Judith M. Fultz)		\$102,720.00	\$102,720.00
The Marjorie Weaver Endowment Fund for Human Cancer Genetics Research (Used to support research at the Comprehensive Cancer Center – The Arthur G. James Cancer Hospital and Richard J. Solove Research Institute; provided by an estate gift from Marjorie Weaver)		\$52,315.00	\$52,315.00
The Dr. Arthur G. and Mildred C. James Professorship in Surgical Oncology Fund (Used to support the salary and research of the surgical oncology chief at the Comprehensive Cancer Center – The Arthur G. James Cancer Hospital and Richard J. Solove Research Institute; provided by gifts from Mrs. Arthur G. James, the James family, friends, and former patients of Arthur G. James)		\$49,069.00	\$49,069.00
Richard D. Johnson Leadership Endowment Fund (Used to provide scholarships to be awarded to Mount Leadership Society Scholar juniors and seniors; provided by gifts from Richard D. Johnson)		\$45,648.00	\$45,648.00

REPORT ON UNIVERSITY DEVELOPMENT (contd)

THE OHIO STATE UNIVERSITY FOUNDATION (contd)

	<u>Previous Gifts</u>	<u>Current Gifts</u>	<u>Total Gifts</u>
<u>Establishment of Named Endowed Funds (contd)</u>			
The Helen, Joseph, Lynne and Steve Skilken Athletic Scholarship Fund for Wrestling (Used to supplement the student-athlete grant-in-aid scholarship costs of a undergraduate member of the OSU men's wrestling team; provided a gift from the Helen and Joseph Skilken Family)		\$40,000.00	\$40,000.00
The Honorable Robert M. Duncan Scholarship Fund (Used to fund a scholarship for an outstanding first-year student entering the Moritz College of Law; provided by a gift from the Honorable Robert M. Duncan)		\$38,000.00	\$38,000.00
The Dr. and Mrs. Richard O. Hecker Dentistry Scholarship Fund (Used to fund a scholarship in the College of Dentistry; provided by a gift from Dr. Richard O. Hecker)		\$35,000.00	\$35,000.00
The Christopher and Suzanne Widing Athletic Scholarship Fund (Used to supplement the student-athlete grant-in-aid scholarship costs of a undergraduate member of the OSU men's varsity lacrosse team who graduated from a Central Ohio public high school; provided by gifts from Christopher and Suzanne Widing)		\$30,000.00	\$30,000.00
The Wastewater Treatment Research Endowment Fund (Used to support graduate research assistance on innovative treatment technology for wastewater; provided by gifts from Dr. Karen Mancl and industry donors)		\$28,250.00	\$28,250.00
The Steven Douglas and Alison Lanza Falls Agricultural Vice President's Fund (Used to support programs identified by the agricultural administration vice president as priorities in the College of Food, Agriculture, and Environmental Sciences; provided by gifts from Steven Douglas Falls and Alison Lanza Falls)		\$27,500.00	\$27,500.00
The A. Louise Gerbig Memorial Fund in Cancer Research (Used to support the area of greatest need in cancer research at the Comprehensive Cancer Center – The Arthur G. James Cancer Hospital and Richard J. Solove Research Institute; provided by a gift from Robert L. and Teri W. Gerbig)		\$26,000.00	\$26,000.00

REPORT ON UNIVERSITY DEVELOPMENT (contd)

THE OHIO STATE UNIVERSITY FOUNDATION (contd)

	<u>Previous Gifts</u>	<u>Current Gifts</u>	<u>Total Gifts</u>
<u>Establishment of Named Endowed Funds (contd)</u>			
The Robert L. Baker Scholarship Fund (Used to provide a scholarship for an undergraduate student majoring in business administration; provided by gifts from Robert L. and Jane Baker)		\$25,004.00	\$25,004.00
The Galloway Family Athletic Scholarship Fund (Used to supplement the grant-in-aid scholarship costs of a student athlete who is an undergraduate member of an OSU varsity team; provided by gifts from Joseph S. Galloway)		\$25,000.00	\$25,000.00
The Gross Family Scholarship Fund in Pharmacy (Used to provide assistance to College of Pharmacy students with an interest in community pharmacy; provided by a gift from Melvin and Adelle Gross)		\$25,000.00	\$25,000.00
The Gustav W. Huhn Endowed Scholarship Fund (Used to provide scholarships for students in the Department of Horticulture and Crop Sciences; provided by gifts Gertrude H. Huhn)		\$25,000.00	\$25,000.00
The Margaret E. Love Endowment Fund for Cancer Research Education and Outreach (Used to support cancer research education and outreach within the Human Cancer Genetics Program at the Comprehensive Cancer Center – The Arthur G. James Cancer Hospital and Richard J. Solove Research Institute; provided by a gift from the estate of Margaret E. Love)		\$25,000.00	\$25,000.00
Total	\$504,913.00	\$2,905,538.36	\$3,410,451.36

THE OHIO STATE UNIVERSITY DEVELOPMENT FUND

Establishment of Named Endowed Funds

The Novice G. Fawcett Scholarship Fund in Educational Administration

The Novice G. Fawcett Scholarship Fund in Educational Administration was established September 6, 2002, by the Board of Trustees of The Ohio State University with gifts from the estate of Novice G. Fawcett (M.A., Education, 1937), president emeritus of The Ohio State University.

All gifts are to be invested in the University's Permanent Endowment Fund, under the rules and regulations adopted by the Board of Trustees of The Ohio State University, with the right to invest and reinvest as occasion dictates.

REPORT ON UNIVERSITY DEVELOPMENT (contd)

THE OHIO STATE UNIVERSITY DEVELOPMENT FUND (contd)

Establishment of Named Endowed Funds (contd)

The Novice G. Fawcett Scholarship Fund in Educational Administration (contd)

The annual income shall be used to provide support to Ph.D. students in the College of Education who are studying with the faculty member who holds the Novice G. Fawcett Chair in Educational Administration. The scholarship will be awarded in consultation with the University Committee on Student Financial Aid.

It is the desire of the donor that this fund should benefit the University in perpetuity. If the need for this fund should cease to exist or so diminish as to provide unused income, then another use shall be designated by the Board of Trustees in consultation with the dean of the College of Education in order to carry out the desire of the donor.

\$100,000.00

The Franz T. Stone Laboratory Research Endowment Fund

The Franz T. Stone Laboratory Research Endowment Fund was established September 6, 2002, by the Board of Trustees of The Ohio State University with gifts from the estate of Katherine D. Stone of Clarence, New York.

All gifts are to be invested in the University's Permanent Endowment Fund, under the rules and regulations adopted by the Board of Trustees of The Ohio State University, with the right to invest and reinvest as occasion dictates.

The annual income from the endowment fund shall be used to support research conducted at the Franz T. Stone Laboratory. Uses of the fund shall include, but not be limited to, support of: student stipends and salaries, student and faculty housing, equipment and supplies, travel and time on research vessels, compensation for resident research monitors and scientists, and research fellowships. Fellowships shall be awarded in consultation with the University Committee on Student Financial Aid.

The use of the annual income shall be directed by the director of the Franz T. Stone Laboratory, in consultation with the director of the Ohio Sea Grant College Program and the Stone Laboratory Scholarship and/or Research Committee.

It is the desire of the donors that this fund should benefit the University in perpetuity. If the need for this fund should cease to exist or so diminish as to provide unused income, then another use shall be designated by the Board of Trustees in consultation with the director of School of Natural Resources and the director of Franz T. Stone Laboratory, or their successor in order to carry out the desire of the donor.

\$38,765.00

The Porterfield-Dickens SPA Assistantship Fund

The Porterfield-Dickens SPA Assistantship Fund was established September 6, 2002, by the Board of Trustees of The Ohio State University with gifts from faculty, staff, and alumni of the Student Affairs/Higher Education Program of The Ohio State University College of Education.

The fund was established to honor the memory of William D. Porterfield (M.A., Education, 1982; Ph.D., Education, 1984) and Cynthia Sullivan Dickens (B.S.Ed., 1970; M.A., Education, 1973; Ph.D., Education, 1994). William is remembered for his fierce passion for learning, his intellectual capacity, commitment, and dedication to quality research and effective practice. Until his death in 1995, he was a brilliant scholar, talented teacher, and skilled trainer. His scholarship continues to

REPORT ON UNIVERSITY DEVELOPMENT (contd)

THE OHIO STATE UNIVERSITY DEVELOPMENT FUND (contd)

Establishment of Named Endowed Funds (contd)

The Porterfield-Dickens SPA Assistantship Fund (contd)

shape the field of higher education. Cynthia was a professor at Mississippi State University until her death in 1997. She worked steadfastly to improve conditions for women in higher education and served as an inspiring role model for all with whom she came into contact. She is remembered for her scholarship and for her work in the field of collaboration and mentoring. People were drawn to her because of her wonderful sense of humor and for her deeply enthusiastic belief in living life to the fullest.

All gifts are to be invested in the University's Permanent Endowment Fund, under the rules and regulations adopted by the Board of Trustees of The Ohio State University, with the right to invest and reinvest as occasion dictates.

When the fund principal totals \$400,000, the annual income shall provide full support for an assistantship (tuition and stipend) to a graduate student in the Student Affairs/Higher Education Program through the Student Personnel Assistantship Program. Selection of the recipient shall be made by the director of the student personnel assistantship program.

Until that time, interest totaling no more than \$2,000 shall be awarded to a student(s) in the form of the Porterfield-Dickens Graduate Research Award. This award will be given to M.A. and/or Ph.D. students who are engaged in research that reflects the values and areas of inquiry modeled by William Porterfield and Cynthia Dickens. Such research may expand theoretical possibilities; critically examine current professional practice and/or reinvent practice; be collaborative; relate to understanding and minimizing the marginalization of individuals based on race, gender, sexual orientation, class or ethnicity; and hold the potential for improving the lives of students. Selection of the recipient shall be made by the director of the Student Personnel Assistantship Program.

Interest in excess of \$2,000 shall be reinvested into principal until the endowment is fully funded at \$400,000.

It is the desire of the donors that this fund should benefit the University in perpetuity. If the need for this fund should cease to exist or so diminish as to provide unused income, then another use shall be designated by the Board of Trustees in consultation with the dean of the College of Education in order to carry out the desire of the donors.

\$34,962.34

John L. Crites Research Fellowship at Stone Laboratory Fund

The John L. Crites Research Fellowship at Stone Laboratory Fund was established September 6, 2002, by the Board of Trustees of The Ohio State University with gifts from alumni and the Friends of Stone Laboratory.

All gifts are to be invested in the University's Permanent Endowment Fund, under the rules and regulations adopted by the Board of Trustees of The Ohio State University, with the right to invest and reinvest as occasion dictates.

The annual income shall be used to support undergraduate and graduate student research awards, with preference to graduate students, for research conducted at Franz Theodore Stone Laboratory. The awards may provide equipment, supplies, travel expenses, or stipends. The selection of the recipients shall be made by the director of Stone Laboratory with input from the Board of Directors of the Friends of Stone Laboratory and the Stone Laboratory Scholarship and/

REPORT ON UNIVERSITY DEVELOPMENT (contd)

THE OHIO STATE UNIVERSITY DEVELOPMENT FUND (contd)

Establishment of Named Endowed Funds (contd)

John L. Crites Research Fellowship at Stone Laboratory Fund (contd)

or Research Committee, and in consultation with the University Committee on Student Financial Aid.

It is the desire of the donors that 10 percent of the income from the endowment shall be reinvested to the principal on an annual basis.

It is the desire of the donors that this fund should benefit the University in perpetuity. If the need for this fund should cease to exist or so diminish as to provide unused income, then another use shall be designated by the Board of Trustees in consultation with the director of School of Natural Resources and the director of Franz Theodore Stone Laboratory, or their successor in order to carry out the desire of the donors.

\$26,290.00

The George A. Krieger University Scholarship Fund

The George A. Krieger University Scholarship Fund was established September 6, 2002, by the Board of Trustees of The Ohio State University with gifts from George A. Krieger (B.S.Bus.Ad., 1950) of Columbus, Ohio, and the Krieger Family of Columbus, Ohio.

All gifts are to be invested in the University's Permanent Endowment Fund, under the rules and regulations adopted by the Board of Trustees of The Ohio State University, with the right to invest and reinvest as occasion dictates.

The annual income shall be used to support a Merit Scholar at the University Scholarship level. The George A. Krieger University Scholarship Fund will fund a University Scholar each year so long as the required grade point average is maintained. This scholarship fund is restricted to students enrolled or planning to enroll in The Max M. Fisher College of Business. The scholarship will be awarded in consultation with the University Committee on Student Financial Aid.

It is the desire of the donors that this fund should benefit the University in perpetuity. If the need for this fund should cease to exist or so diminish as to provide unused income, then another use shall be designated by the Board of Trustees in consultation with the dean of the Fisher College of Business and the associate provost for Honors and Scholars in the Office of Academic Affairs in order to carry out the desire of the donors.

\$15,000.00 (grandfathered)

The Seubert Family Chadwick Arboretum Guest Lecturer Endowment Fund

The Seubert Family Chadwick Arboretum Guest Lecturer Endowment Fund was established September 6, 2002, by the Board of Trustees of The Ohio State University with gifts from Howard P. Seubert, (matching gift from Rockwell International), and Mariruth Dresbach Seubert, (M.A., 1958) an avid gardener and wife of Howard who participated in the first Franklin County Master Gardener Class in 1993 and has been a longtime supporter and volunteer of the Chadwick Arboretum. Gifts were also given by Suzanne Seubert-Rowan (J.D., 1981), Stuart H. Seubert, and Steven M. Seubert, children of Howard and Mariruth.

REPORT ON UNIVERSITY DEVELOPMENT (contd)

THE OHIO STATE UNIVERSITY DEVELOPMENT FUND (contd)

Establishment of Named Endowed Funds (contd)

The Seubert Family Chadwick Arboretum Guest Lecturer Endowment Fund (contd)

All gifts are to be invested in the University's Permanent Endowment Fund, under the rules and regulations adopted by the Board of Trustees of The Ohio State University, with the right to invest and reinvest as occasion dictates.

The preferred use of the annual income shall be to support a guest lecturer at the Chadwick Arboretum. Other uses could include the sponsorship of educational programs with a focus on public horticultural education. In addition, the income can also be used for any other programs deemed desirable in connection with the operation of the Chadwick Arboretum in the Department of Horticulture and Crop Science in the College of Food, Agricultural, and Environmental Sciences at The Ohio State University.

It is the desire of the donors that this fund should benefit the University in perpetuity. If the need for this fund should cease to exist or so diminish as to provide unused income, then another use shall be designated by the Board of Trustees in consultation with the vice president for Agricultural Administration and University Outreach, and executive dean for Food, Agricultural and Environmental Sciences, and the chairperson of the Department of Horticulture and Crop Science, or their successor, in order to carry out the desire of the donors.

\$5,500.00 (grandfathered)

Change in Name and Description of Named Endowed Funds

T. Kline Hamilton Award Fund

The T. Kline Hamilton Award was established October 3, 1980, by the Board of Trustees of The Ohio State University with a gift from the Columbus Division – Dairy and Nutrition Council, now known as American Dairy Association and Dairy Council Mid East. The name and description were revised on September 6, 2002.

All gifts are to be invested in the University's Permanent Endowment Fund, under the rules and regulations adopted by the Board of Trustees of The Ohio State University, with the right to invest and reinvest as occasion dictates.

The annual income shall be used to support graduate research related to the nutritional aspects of dairy products in the Department of Human Nutrition as well as The Ohio State University Interdisciplinary Ph.D. Program in the Department of Human Nutrition. The award will be made by the dean of the College of Human Ecology based on the recommendations of the T. Kline Hamilton Award Committee.

It is the desire of the donor that this fund should benefit the University in perpetuity. If the need for this fund should cease to exist or so diminish as to provide unused income, then another use shall be designated by the Board of Trustees with preference being given to the recommendations from the appropriate administrative official of the University who is then directly responsible for the College of Human Ecology in order to carry out the desire of the donor.

Larry Prude Memorial Minority Scholarship Fund

The Marion Campus Minority Scholarship Fund was established December 14, 1984, by the Board of Trustees of The Ohio State University with a gift from the OSU Marion Campus Minority Advisory Committee. The name and description were revised on September 6, 2002.

REPORT ON UNIVERSITY DEVELOPMENT (contd)

THE OHIO STATE UNIVERSITY DEVELOPMENT FUND (contd)

Change in Name and Description of Named Endowed Funds (contd)

Larry Prude Memorial Minority Scholarship Fund (contd)

All gifts are to be invested in the University's Permanent Endowment Fund, under the rules and regulations adopted by the Board of Trustees of The Ohio State University, with the right to invest and reinvest as occasion dictates.

The annual income shall be used to provide one or more scholarships to deserving minority students of merit who are entering The Ohio State University and who enroll at the Marion Campus. The selection of the recipient(s) is to be made upon the recommendation of The Ohio State University Marion Campus Minority Scholarship Committee in consultation with the dean and director of the Marion Campus and the University Committee on Student Financial Aid.

It is the desire of the donor that this fund should benefit the University in perpetuity. If the need for this fund should cease to exist or so diminish as to provide unused income, then another use shall be designated by the Board of Trustees with preference being given to recommendations for the appropriate administrative official who is responsible for minority scholarships and who will identify recipients from the Marion, Ohio, area attending The Ohio State University in order to carry out the desire of the donor.

Change in Description of Named Endowed Fund

The Helen Strow International Programs Fund in the College of Human Ecology

The Helen Strow International Programs Fund in the College of Human Ecology was established June 29, 2001, by the Board of Trustees of The Ohio State University with lead gifts from Dr. Genevieve B. Schroeder (B.S.H.E., 1955; M.S., 1973; Ph.D., 1978), the estate of Helen Strow (B.S.H.E., 1925; M.S., 1931), and the estate of Dr. Florence J. Neuman (B.S.H.E., 1926; M.S., 1938; Ph.D., 1943). The description was revised on September 6, 2002.

All gifts are to be invested in the University's Permanent Endowment Fund, under the rules and regulations adopted by the Board of Trustees of The Ohio State University, with the right to invest and reinvest as occasion dictates.

The annual income shall be used to support three separate purposes as follows:

- Three-year scholarship at the College of Human Ecology for undergraduate students from countries without an accredited university baccalaureate program – scholarships will be awarded in consultation with the University Committee on Student Financial Aid;
- Short-term international study tours or courses at universities abroad that will give College of Human Ecology students the chance to expand their knowledge of and experiences with families and communities worldwide; and
- Biannual support for an international student at the college to attend a national professional meeting, and for a U.S. student to attend an international professional meeting.

It is the desire of the donors that this fund should benefit the University in perpetuity. If the need for this fund should cease to exist or so diminish as to provide unused income, then another use shall be designated by the Board of Trustees with preference being given to the recommendations from the appropriate administrative official of the University who is then directly responsible for the College of Human Ecology in order to carry out the desire of the donors.

REPORT ON UNIVERSITY DEVELOPMENT (contd)

THE OHIO STATE UNIVERSITY FOUNDATION

Establishment of Named Endowed Chair

Ruth Stanton Chair in Veterinary Medicine

The Ruth Stanton Chair in Veterinary Medicine was established September 6, 2002, in accordance with the guidelines approved by the Board of Directors of The Ohio State University Foundation, with a gift from Frank Stanton (M.A., 1932; Ph.D., 1935) in memory of his wife, Ruth.

All gifts are to be invested by the Foundation, under the rules and regulations adopted by the Foundation's Board of Directors, with the right to invest and reinvest as occasion dictates.

The annual income will support a chair in the College of Veterinary Medicine to provide the opportunity to attract/retain the best leadership possible.

It is the desire of the donor that this fund should benefit the University in perpetuity. If the need for this fund should cease to exist or so diminish as to provide unused income, then another use shall be designated by the Foundation Board as recommended by the person or unit with spending authority and/or appropriate University official in order to carry out the desire of the donor.

\$1,504,404.00

Establishment of Named Endowed Funds

The Excellence in Radiology Endowment Fund

The Excellence in Radiology Endowment Fund was established September 6, 2002, in accordance with the guidelines approved by the Board of Directors of The Ohio State University Foundation, with gifts from corporations (with a major gift from Ambulatory Imaging Inc.), foundations and individual donors (including faculty, alumni, and patients); and given to enhance the ongoing programs and strengthen special initiatives in the Department of Radiology.

All gifts are to be invested by the Foundation, under the rules and regulations adopted by the Foundation's Board of Directors, with the right to invest and reinvest as occasion dictates.

The annual income shall be used to support priorities in the Department of Radiology in the College of Medicine and Public Health including research, education, faculty development, training projects, and professorships or chairs at the discretion of the chairperson of the Department of Radiology. For research, the income may support, but is not limited to: scientific supplies, equipment, salaries for research personnel and activities required for quality medical research. In any given year that the endowment income is not fully expended, the unused portion should be reinvested in the endowment principal.

If funding reaches the level of \$750,000, the income may, at the recommendation of the chairperson of the Department of Radiology, be used for a professorship position supporting a distinguished scholar in the Department of Radiology. Appointment shall be made at the recommendation of the chairperson of the Department of Radiology in consultation with the senior vice president for Health Sciences and dean of the College of Medicine and Public Health.

If funding reaches the chair level of \$1,500,000, the professorship may, at the recommendation of the chairperson of the Department of Radiology, be converted to a chair in the Department of Radiology. The chair position shall be held by a nationally eminent faculty member as recommended by the chairperson of the Department of Radiology in consultation with the senior vice president for Health Sciences and dean of the College of Medicine and Public Health. The activities of the holder of the professorship or the chair shall be reviewed no less than every five years by the senior vice president for Health Sciences and dean of the College of Medicine and

REPORT ON UNIVERSITY DEVELOPMENT (contd)

THE OHIO STATE UNIVERSITY FOUNDATION (contd)

Establishment of Named Endowed Funds (contd)

The Excellence in Radiology Endowment Fund (contd)

Public Health to determine compliance with the intent of the donors as well as the academic and research standards of the University.

It is the desire of the donors that this fund should benefit the University in perpetuity. If the need for this fund should cease to exist or so diminish as to provide unused income, then another use shall be designated by the Foundation Board in consultation with the chairperson of the Department of Radiology and with the senior vice president for Health Sciences and dean of the College of Medicine and Public Health in order to carry out the desire of the donors.

\$581,111.02

The George A. and Jean M. Madden
Parkinson's Disease/Movement Disorders Endowment Fund

The George A. and Jean M. Madden Parkinson's Disease/Movement Disorders Endowment Fund was established September 6, 2002, in accordance with the guidelines approved by the Board of Directors of The Ohio State University Foundation, with gifts from the estate of George A. Madden; from his wife, Jean M. Madden of Dublin, Ohio; and from the George A. and Jean M. Madden Foundation.

All gifts are to be invested by the Foundation, under the rules and regulations adopted by the Foundation's Board of Directors, with the right to invest and reinvest as occasion dictates.

The annual income shall be used to support the interdisciplinary research and education being conducted in the "George and Jean Madden – National Parkinson Foundation Parkinson's Disease Center for Excellence," with emphasis on seeking the CAUSE of Parkinson's Disease. Allocation of annual income shall be made at the recommendation of the director of the Madden/NPF Parkinson's Disease Center in consultation with the chairperson of the Department of Neurology and the senior vice president for Health Sciences and dean of the College of Medicine and Public Health.

It is the desire of the donors that this fund should benefit the University in perpetuity. If the need for this fund should cease to exist or so diminish as to provide unused income, then another use shall be designated by the Foundation Board in consultation with the senior vice president for Health Sciences and dean of the College of Medicine and Public Health and the director of the Madden – NPF Parkinson's Disease Center in order to carry out the desire of the donors.

\$504,913.00

The Fultz Family Athletic Scholarship Fund

The Fultz Family Athletic Scholarship Fund was established September 6, 2002, in accordance with guidelines approved by the Board of Directors of The Ohio State University Foundation with gifts from Robert E. Fultz (B.A., 1963) and Judith M. Fultz (B.S., 1963) both of Columbus, Ohio, and Naples, Florida.

All gifts are to be invested by the Foundation, under the rules and regulations adopted by the Foundation Board of Directors, with the right to invest and reinvest as occasion dictates.

The annual income shall be used to provide scholarship costs of student athletes who are pursuing undergraduate degrees at The Ohio State University and participating on the varsity

REPORT ON UNIVERSITY DEVELOPMENT (contd)

THE OHIO STATE UNIVERSITY FOUNDATION (contd)

Establishment of Named Endowed Funds (contd)

The Fultz Family Athletic Scholarship Fund (contd)

football team. Recipients shall be selected by the director of Athletics in consultation with the University Committee on Student Financial Aid.

It is the desire of the donors that this fund should benefit the University in perpetuity. If the need for this fund should cease to exist or so diminish as to provide unused income, then another use shall be designated by the Foundation Board as recommended by the director of Athletics in order to carry out the desire of the donors.

\$102,720.00

The Marjorie Weaver Endowment Fund for Human Cancer Genetics Research

The Marjorie Weaver Endowment Fund for Human Cancer Genetics Research to support Human Cancer Genetics Research for the Comprehensive Cancer Center – The Arthur G. James Cancer Hospital and Richard J. Solove Research Institute was established September 6, 2002, in accordance with the guidelines approved by the Board of Directors of The Ohio State University Foundation, with an estate gift from Marjorie Weaver.

All gifts are to be invested by the Foundation, under the rules and regulations adopted by the Foundation's Board of Directors, with the right to invest and reinvest as occasion dictates.

The annual income shall be used to support Human Cancer Genetics Research at the Comprehensive Cancer Center – The Arthur G. James Cancer Hospital and Richard J. Solove Research Institute at The Ohio State University as approved by the director of The Arthur G. James Cancer Hospital and Richard J. Solove Research Institute, the director of the Comprehensive Cancer Center, and the senior vice president for Health Sciences and dean of the College of Medicine and Public Health. Any unused income shall be returned to the principal of this fund.

It is the desire of the donor that this fund should benefit the University in perpetuity. If the need for this fund should cease to exist or so diminish as to provide unused income, then another use shall be designated by the Foundation Board in consultation with the director of The Arthur G. James Cancer Hospital and Richard J. Solove Research Institute, the director of the Comprehensive Cancer Center, and the senior vice president for Health Sciences and dean of the College of Medicine and Public Health in order to carry out the desire of the donor.

\$52,315.00

The Dr. Arthur G. and Mildred C. James Professorship in Surgical Oncology Fund

The Dr. Arthur G. and Mildred C. James Professorship in Surgical Oncology Fund at the Comprehensive Cancer Center – The Arthur G. James Cancer Hospital and Richard J. Solove Research Institute was established September 6, 2002, in accordance with the guidelines approved by the Board of Directors of The Ohio State University Foundation, with gifts from Mrs. Arthur G. James, the James family, friends, and former patients of Arthur G. James, M.D.

All gifts are to be invested by the Foundation, under the rules and regulations adopted by the Foundation's Board of Directors, with the right to invest and reinvest as occasion dictates.

REPORT ON UNIVERSITY DEVELOPMENT (contd)

THE OHIO STATE UNIVERSITY FOUNDATION (contd)

Establishment of Named Endowed Funds (contd)

The Dr. Arthur G. and Mildred C. James Professorship in Surgical Oncology Fund (contd)

The annual income shall be used to support the salary and research of the Chief of Surgical Oncology at the Comprehensive Cancer Center – The Arthur G. James Cancer Hospital and Richard J. Solove Research Institute at The Ohio State University as approved by the director of The Arthur G. James Cancer Hospital, the director of the Comprehensive Cancer Center, and the senior vice president for Health Sciences and dean of the College of Medicine and Public Health.

If the principal of the endowment reaches \$1,500,000, The Dr. Arthur G. and Mildred C. James Professorship in Surgical Oncology shall be converted to The Dr. Arthur G. and Mildred C. James Chair in Surgical Oncology. The annual income shall be used to support the salary and research of an eminent scholar in surgical oncology at the Comprehensive Cancer Center – The Arthur G. James Cancer Hospital and Richard J. Solove Research Institute at The Ohio State University.

The Dr. Arthur G. and Mildred C. James Professorship in Surgical Oncology appointment shall be made upon the recommendation of the director of The Arthur G. James Cancer Hospital and Richard J. Solove Research Institute and the director of the Comprehensive Cancer Center, in consultation with the senior vice president for Health Sciences and dean of the College of Medicine and Public Health. The activities of the appointee shall be reviewed no less than every five years by the director of The Arthur G. James Cancer Hospital and Richard J. Solove Research Institute and the director of the Comprehensive Cancer Center, in consultation with the senior vice president for Health Sciences and dean of the College of Medicine and Public Health to determine compliance with the intent of the donor as well as the academic and research standards of the University.

It is the desire of the donors that this fund should benefit the University in perpetuity. If the need for this fund should cease to exist or so diminish as to provide unused income, then another use shall be designated by the Foundation Board in consultation with the director of The Arthur G. James Cancer Hospital and Richard J. Solove Research Institute, the director of the Comprehensive Cancer Center, and the senior vice president for Health Sciences and dean of the College of Medicine and Public Health in order to carry out the desire of the donors.

\$49,069.00

Richard D. Johnson Leadership Endowment Fund

The Richard D. Johnson Leadership Endowment Fund was established September 6, 2002, in accordance with the guidelines approved by the Board of Directors of The Ohio State University Foundation, with gifts from Richard Darrell Johnson (B.I.E., 1958; M.B.A., 1962) of Lake Forest, Illinois.

All gifts are to be invested by the Foundation, under the rules and regulations adopted by the Foundation's Board of Directors, with the right to invest and reinvest as occasion dictates.

The annual income shall be used to provide one or more scholarships that will be awarded to one or more Mount Leadership Society Scholar upperclassmen. The associate provost for Honors and Scholars in the Office of Academic Affairs and the director of the Mount Leadership Society will choose the recipient(s) using the criteria that the awardee(s) must possess leadership qualities that emulate the life and celebrate the achievements of Ruth Wiemer Mount. These qualities must have been demonstrated by being selected to a junior class honorary and/or senior class honorary; elected to a leadership position in The Ohio State University residence halls, student government, service organizations such as Ohio Staters, Inc., or other major co-curricular organizations; and have outstanding leadership/scholarship attributes that were exhibited during

REPORT ON UNIVERSITY DEVELOPMENT (contd)

THE OHIO STATE UNIVERSITY FOUNDATION (contd)

Establishment of Named Endowed Funds (contd)

Richard D. Johnson Leadership Endowment Fund (contd)

the two years of being a Mount Scholar. Scholarships will be awarded in consultation with the University Committee on Student Financial Aid.

It is the desire of the donor that this fund should benefit the University in perpetuity. If the need for this fund should cease to exist or so diminish as to provide unused income, then another use shall be designated by the Foundation Board in consultation with the associate provost for Honors and Scholars in the Office of Academic Affairs, president of the University Foundation, and the director of Student Financial Aid in order to carry out the desire of the donor.

\$45,648.00

The Helen, Joseph, Lynne and Steve Skilken Athletic Scholarship Fund for Wrestling

The Helen, Joseph, Lynne and Steve Skilken Athletic Scholarship Fund for Wrestling was established September 6, 2002, in accordance with the guidelines approved by the Board of Directors of The Ohio State University Foundation, with a gift from the Helen and Joseph Skilken family.

All gifts are to be invested by the Foundation, under the rules and regulations adopted by the Foundation's Board of Directors, with the right to invest and reinvest as occasion dictates.

The annual income shall be used to supplement the student-athlete grant-in-aid scholarship costs of a student-athlete who is a member of the men's wrestling team pursuing an undergraduate degree at The Ohio State University. The recipient will be selected by the director of Athletics in consultation with the University Committee on Student Financial Aid.

It is the desire of the donors that this fund should benefit the University in perpetuity. If the need for this fund should cease to exist or so diminish as to provide unused income, then another use shall be designated by the Foundation Board as recommended by the director of Athletics in order to carry out the desire of the donors.

\$40,000.00

The Honorable Robert M. Duncan Scholarship Fund

The Honorable Robert M. Duncan Scholarship Fund was established September 6, 2002, in accordance with the guidelines approved by the Board of Directors of The Ohio State University Foundation, with a gift from the Honorable Robert M. Duncan (B.S.Ed., 1948; J.D., 1952; Ph.D., 1979 - honorary) from Columbus, Ohio.

All gifts are to be invested by the Foundation, under the rules and regulations adopted by the Foundation's Board of Directors, with the right to invest and reinvest as occasion dictates.

The annual income shall be used to fund a scholarship for an outstanding first-year student entering The Michael E. Moritz College of Law who, by virtue of their background and accomplishments, will contribute to the intellectual and social diversity of the entering class. Special consideration will be given to African-American students and others who, because of their social and educational backgrounds and life experiences, have the potential to bring new perspectives to the study of law and the legal profession. The scholarship will be awarded in consultation with the University Committee on Student Financial Aid.

REPORT ON UNIVERSITY DEVELOPMENT (contd)

THE OHIO STATE UNIVERSITY FOUNDATION (contd)

Establishment of Named Endowed Funds (contd)

The Honorable Robert M. Duncan Scholarship Fund (contd)

It is the desire of the donors that this fund should benefit the University in perpetuity. If the need for this fund should cease to exist or so diminish as to provide unused income, then another use shall be designated by the Foundation Board in consultation with the dean of the Moritz College of Law in order to carry out the desire of the donor.

\$38,000.00

The Dr. and Mrs. Richard O. Hecker Dentistry Scholarship Fund

The Dr. and Mrs. Richard O. Hecker Dentistry Scholarship Fund was established September 6, 2002, in accordance with the guidelines approved by the Board of Directors of The Ohio State University Foundation, with a gift from Dr. Richard O. Hecker, (D.D.S., 1957) from Hot Springs Village, Arkansas.

All gifts are to be invested by the Foundation, under the rules and regulations adopted by the Foundation's Board of Directors, with the right to invest and reinvest as occasion dictates.

The annual income shall be used to fund a scholarship in the College of Dentistry, with a preference given to an incoming or continuing dental student who has maintained a cumulative GPA of 2.75 or above. The scholarship will be awarded in consultation with the University Committee on Student Financial Aid.

It is the desire of the donors that this fund should benefit the University in perpetuity. If the need for this fund should cease to exist or so diminish as to provide unused income, then another use shall be designated by the Foundation Board in consultation with the dean of the College of Dentistry in order to carry out the desire of the donors.

\$35,000.00

The Christopher and Suzanne Widing Athletic Scholarship Fund

The Christopher and Suzanne Widing Athletic Scholarship Fund was established September 6, 2002, in accordance with the guidelines approved by the Board of Directors of The Ohio State University Foundation, with gifts from Christopher (B.S.Bus.Adm., 1970; M.B.A., 1979) and Suzanne (B.S., 1970) Widing of Columbus, Ohio.

All gifts are to be invested by the Foundation, under the rules and regulations adopted by the Foundation's Board of Directors, with the right to invest and reinvest as occasion dictates.

The annual income shall be used to supplement the student-athlete grant-in-aid scholarship costs of a student athlete who is a member of the men's varsity lacrosse team and is from a Central Ohio public high school pursuing an undergraduate degree at The Ohio State University. The director of Athletics will select the recipient in consultation with the University Committee on Student Financial Aid.

It is the desire of the donors that this fund should benefit the University in perpetuity. If the need for this fund should cease to exist or so diminish as to provide unused income, then another use shall be designated by the Foundation Board as recommended by the director of Athletics in order to carry out the desire of the donors.

\$30,000.00

REPORT ON UNIVERSITY DEVELOPMENT (contd)

THE OHIO STATE UNIVERSITY FOUNDATION (contd)

Establishment of Named Endowed Funds (contd)

The Wastewater Treatment Research Endowment Fund

The Wastewater Treatment Research Endowment Fund was established September 6, 2002, in accordance with the guidelines approved by the Board of Directors of The Ohio State University Foundation, with gifts from Dr. Karen Mancl, professor in the Department of Food, Agricultural, and Biological Engineering, and industry donors.

All gifts are to be invested by the Foundation, under the rules and regulations adopted by the Foundation's Board of Directors, with the right to invest and reinvest as occasion dictates.

The annual income shall be used to support graduate research assistance on innovative treatment technology for wastewater. Income shall be directed by the chairperson of the Department of Food, Agricultural, and Biological Engineering, in consultation with the faculty member who currently directs the wastewater research in the Department of Food, Agricultural, and Biological Engineering.

It is the desire of the donors that this fund should benefit the University in perpetuity. If the need for this fund should cease to exist or so diminish as to provide unused income, then another use shall be designated by the Foundation Board in consultation with the vice president for Agricultural Administration and University Outreach, and executive dean for Food, Agricultural and Environmental Sciences, and the chairperson of the Department of Food, Agricultural, and Biological Engineering, or their successor, or program administrative officer in order to carry out the desire of the donors.

\$28,250.00

The Steven Douglas and Alison Lanza Falls Agricultural Vice President's Fund

The Steven Douglas and Alison Lanza Falls Agricultural Vice President's Fund was established September 6, 2002, in accordance with the guidelines approved by the Board of Directors of The Ohio State University Foundation from Steven Douglas Falls, (B.S., 1969; M.S., 1972) and Alison Lanza Falls (M.A., 1972), of Port Clinton, Ohio.

All gifts are to be invested by the Foundation, under the rules and regulations adopted by the Foundation's Board of Directors, with the right to invest and reinvest as occasion dictates.

The annual income shall be used to support programs identified by the vice president for Agricultural Administration and University Outreach, and executive dean for Food, Agricultural and Environmental Sciences as current and critical priorities in the College of Food, Agricultural, and Environmental Sciences. Uses of the fund shall include, but not be limited to support of: positive, creative work environment for students, faculty and staff; "outreach" to our external audiences; encouragement and promotion of student organizations, scholarships, professional development; college promotion and advancement; and other emerging college priorities. Scholarships will be awarded in consultation with the University Committee on Student Financial Aid.

The use of the annual income shall be directed by the vice president for Agricultural Administration and University Outreach, and executive dean for Food, Agricultural and Environmental Sciences, or their designee.

It is the desire of the donors that this fund should benefit the University in perpetuity. If the need for this fund should cease to exist or so diminish as to provide unused income, then another use shall be designated by the Foundation Board in consultation with the vice president for

REPORT ON UNIVERSITY DEVELOPMENT (contd)

THE OHIO STATE UNIVERSITY FOUNDATION (contd)

Establishment of Named Endowed Funds (contd)

The Steven Douglas and Alison Lanza Falls Agricultural Vice President's Fund (contd)

Agricultural Administration and University Outreach, and executive dean for Food, Agricultural and Environmental Sciences, or their successor, in order to carry out the desire of the donors.

\$27,500.00

The A. Louise Gerbig Memorial Fund in Cancer Research

The A. Louise Gerbig Memorial Fund in Cancer Research at the Comprehensive Cancer Center – The Arthur G. James Cancer Hospital and Richard J. Solove Research Institute was established September 6, 2002, in accordance with the guidelines approved by the Board of Directors of The Ohio State University Foundation, with a gift from Robert L. (B.A., 1967) and Teri W. Gerbig of Powell, Ohio.

All gifts are to be invested by the Foundation, under the rules and regulations adopted by the Foundation's Board of Directors, with the right to invest and reinvest as occasion dictates.

The annual income shall be used to support the area of greatest need in cancer research at the Comprehensive Cancer Center – The Arthur G. James Cancer Hospital and Richard J. Solove Research Institute at The Ohio State University as approved by the director of The Arthur G. James Cancer Hospital and Richard J. Solove Research Institute, the director of the Comprehensive Cancer Center, and the senior vice president for Health Sciences and dean of the College of Medicine and Public Health.

It is the desire of the donors that this fund should benefit the University in perpetuity. If the need for this fund should cease to exist or so diminish as to provide unused income, then another use shall be designated by the Foundation Board in consultation with the director of The Arthur G. James Cancer Hospital and Richard J. Solove Research Institute, the director of the Comprehensive Cancer Center, and the senior vice president of Health Sciences and dean of the College of Medicine and Public Health in order to carry out the desire of the donors

\$26,000.00

The Robert L. Baker Scholarship Fund

The Robert L. Baker Scholarship Fund was established September 6, 2002, in accordance with the guidelines approved by the Board of Directors of The Ohio State University Foundation, with gifts from Robert L. (B.S.Bus.Adm., 1949) and his wife, Jane Baker.

All gifts are to be invested by the Foundation, under the rules and regulations adopted by the Foundation's Board of Directors, with the right to invest and reinvest as occasion dictates.

The annual income shall be used to provide a scholarship for an undergraduate student majoring in business administration. The scholarship will be awarded in consultation with the University Committee on Student Financial Aid.

It is the desire of the donors that this fund should benefit the University in perpetuity. If the need for this fund should cease to exist or so diminish as to provide unused income, then another use shall be designated by the Foundation Board in consultation with the dean of The Max M. Fisher College of Business in order to carry out the desire of the donors.

\$25,004.00

REPORT ON UNIVERSITY DEVELOPMENT (contd)

THE OHIO STATE UNIVERSITY FOUNDATION (contd)

Establishment of Named Endowed Funds (contd)

The Galloway Family Athletic Scholarship Fund

The Galloway Family Athletic Scholarship Fund was established September 6, 2002, in accordance with the guidelines approved by the Board of Directors of The Ohio State University Foundation, with gifts from Joseph S. Galloway of Columbus, Ohio.

All gifts are to be invested by the Foundation, under the rules and regulations adopted by the Foundation's Board of Directors, with the right to invest and reinvest as occasion dictates.

The annual income shall be used to supplement the grant-in-aid scholarship costs of a student athlete who is a member of a varsity team pursuing an undergraduate degree at The Ohio State University. The first preference for the recipient of the award is a student from Bellaire High School. The second preference is a student athlete involved in the sports of football, basketball, track, or baseball from the conference that Bellaire High School is a member, which currently is the Ohio Valley Athletic Conference (OVAC). If a candidate cannot be found meeting the qualifications ascribed above, the scholarship may be awarded to a member of the football team. On not less than an annual basis, written notification will be sent to Mr. Galloway stating the name of the recipient of this award, background information on the recipient and verification that the recipients selection was consistent with the selection criterion. Recipients shall be selected by the director of Athletics in consultation with the University Committee on Student Financial Aid.

It is the desire of the donor that this fund should benefit the University in perpetuity. If the need for this fund should cease to exist or so diminish as to provide unused income, then another use shall be designated by the Foundation Board as recommended by the director of Athletics in order to carry out the desire of the donor.

\$25,000.00

The Gross Family Scholarship Fund in Pharmacy

The Gross Family Scholarship Fund in Pharmacy was established September 6, 2002, in accordance with the guidelines approved by the Board of Directors of The Ohio State University Foundation, with a gift from Melvin (B.S.Pharm., 1965) and Adelle Gross (B.S., Med. Tech., 1965) of Los Angeles, California.

All gifts are to be invested by the Foundation, under the rules and regulations adopted by the Foundation's Board of Directors, with the right to invest and reinvest as occasion dictates.

The annual income shall be used to provide assistance to a College of Pharmacy student(s) in good standing who demonstrates financial need, and has an interest in community pharmacy. The recipient(s) of the scholarship shall be determined by the dean of the College of Pharmacy and/or his/her designee. Scholarships will be awarded in consultation with the University Committee on Student Financial Aid.

It is the desire of the donors that this fund should benefit the University in perpetuity. If the need for this fund should cease to exist or so diminish as to provide unused income, then another use shall be designated by the Foundation Board in consultation with the dean of the College of Pharmacy and the donors in order to carry out the desire of the donors.

\$25,000.00

REPORT ON UNIVERSITY DEVELOPMENT (contd)

THE OHIO STATE UNIVERSITY FOUNDATION (contd)

Establishment of Named Endowed Funds (contd)

The Gustav W. Huhn Endowed Scholarship Fund

The Gustav W. Huhn Endowed Scholarship Fund was established September 6, 2002, in accordance with the guidelines approved by the Board of Directors of The Ohio State University Foundation, with gifts from Gertrude H. Huhn of Cleveland, Ohio.

All gifts are to be invested by the Foundation, under the rules and regulations adopted by the Foundation's Board of Directors, with the right to invest and reinvest as occasion dictates.

The annual income shall be used to provide scholarship(s) for students who are enrolled in the Department of Horticulture and Crop Science, with priority based on a concentration of study in the field of floriculture. The selection will be made in consultation with the University Committee on Student Financial Aid

It is the desire of the donor that this fund should benefit the University in perpetuity. If the need for this fund should cease to exist or so diminish as to provide unused income, then another use shall be designated by the Foundation Board in consultation with the vice president for Agricultural Administration and University Outreach, and executive dean for Food, Agricultural and Environmental Sciences, and the chairperson of the Department of Horticulture and Crop Science, or their successor, in order to carry out the desire of the donor.

\$25,000.00

The Margaret E. Love Endowment Fund
for Cancer Research Education and Outreach

The Margaret E. Love Endowment Fund for Cancer Research Education and Outreach at the Comprehensive Cancer Center – The Arthur G. James Cancer Hospital and Richard J. Solove Research Institute was established September 6, 2002, in accordance with the guidelines approved by the Board of Directors of The Ohio State University Foundation, with a gift from the estate of Margaret E. Love (B.S.Ed., 1941; M.A., 1962) of Bexley, Ohio.

All gifts are to be invested by the Foundation, under the rules and regulations adopted by the Foundation's Board of Directors, with the right to invest and reinvest as occasion dictates.

The annual income shall be used to support cancer research education and outreach within the Human Cancer Genetics Program at the Comprehensive Cancer Center – The Arthur G. James Cancer Hospital and Richard J. Solove Research Institute at The Ohio State University as approved by the director of The Arthur G. James Cancer Hospital and Richard J. Solove Research Institute, the director of the Comprehensive Cancer Center, and the senior vice president for Health Sciences and dean of the College of Medicine and Public Health.

It is the desire of the donor that this fund should benefit the University in perpetuity. If the need for this fund should cease to exist or so diminish as to provide unused income, then another use shall be designated by the Foundation Board in consultation with the director of The Arthur G. James Cancer Hospital and Richard J. Solove Research Institute, the director of the Comprehensive Cancer Center, the senior vice president of Health Sciences and dean of the College of Medicine and Public Health in order to carry out the desire of the donor.

\$25,000.00

**AUTHORIZATION FOR DESIGNATED OFFICIALS
TO BUY, SELL, ASSIGN AND TRANSFER SECURITIES,
TO DEPOSIT OR WITHDRAW FUNDS FROM BANK ACCOUNTS,
AND TO DESIGNATE DEPOSITORIES**

Resolution No. 2003-32

Synopsis: Reauthorization for designated officials to buy, sell, assign, and transfer securities, to deposit or withdraw funds from bank and investment accounts held in the name of The Ohio State University, to designate depositories, and to execute related agreements is proposed.

WHEREAS designated officials of the University buy, sell, assign, and transfer stocks, bonds, and other financial instruments owned by The Ohio State University; and

WHEREAS various financial institutions are designated as depositories of The Ohio State University; and

WHEREAS accounts at various financial institutions are opened and maintained in the name of The Ohio State University:

NOW THEREFORE

BE IT RESOLVED, That the Treasurer and/or Senior Vice President for Business and Finance and Chief Financial Officer be authorized to buy, sell, assign, and transfer any and all stocks, bonds, evidence of interest and/or indebtedness, interests in charitable remainder trust(s) not to exceed a net gift of \$250,000 or a trust market value of \$5 million, insurance investments, rights and options to acquire or to sell the same, and all other securities corporate or otherwise, standing in the name of or belonging to The Ohio State University in any capacity; and

BE IT FURTHER RESOLVED, That these officials be authorized to designate various financial institutions as depositories for The Ohio State University and to open and maintain accounts at various financial institutions in the name of The Ohio State University; to sign agreements for bank, investment and financial services; and

BE IT FURTHER RESOLVED, That these officials be authorized, on behalf of The Ohio State University and in its name, to sign checks, drafts, notes, bills of exchange, letters of credit, acceptances or other orders for the payment of money from said accounts; to endorse in writing or by stamp checks, notes, bills, certificates of deposit or other instruments owned or held by this University for deposit in said accounts or for collection or discount by said banks; to accept drafts, acceptances, and other instruments payable to said banks; to waive, demand, protest, file notice of protest, or dishonor any check, note, bill, draft or other instrument made, drawn or endorsed by the University.

FUNDING FOR UNIVERSITY DEVELOPMENT

Resolution No. 2003-33

Synopsis: Recommendation for the modification of the funding plan for University Development is proposed.

WHEREAS in July 2000 the Board of Trustees adopted a funding plan for University Development to support fund raising without General Funds support; and

WHEREAS continued investment in fund raising is needed to protect and enhance the University's ability to acquire private gift support:

NOW THEREFORE

FUNDING FOR UNIVERSITY DEVELOPMENT (contd)

BE IT RESOLVED, That effective July 1, 2002, the current 1.1% charge against all endowments be increased to 1.33% in order to fully support fund raising and other custodial and stewardship activities; and

BE IT FURTHER RESOLVED, That the University report back to the Investments Committee on a long-term funding plan as provided in Appendix XIV.

(See Appendix XIV for background information, page 389.)

**EMPLOYMENT OF ARCHITECTS/ENGINEERS,
EMPLOYMENT OF CONSTRUCTION MANAGER, AND
REQUEST FOR CONSTRUCTION BIDS**

Resolution No. 2003-34

THOMPSON LIBRARY RENOVATION
CAMERA CENTER – HOSPITAL LABS
FRY HALL ADDITION
MEDICAL CENTER CENTRAL CHILLED WATER EXPANSION
HEALTH SCIENCES QUADRANGLE
DAVIS HEART AND LUNG INSTITUTE - BASEMENT
WILCE STUDENT HEALTH CENTER RENOVATION – PHASE 2
GRAVES HALL – ULAR RENOVATIONS
WOMEN'S FIELD HOUSE RELOCATION
DAVIS HEART AND LUNG INSTITUTE – ROOM 089
PFAHL HALL EXECUTIVE DINING ROOM
TZAGOURNIS MEDICAL RESEARCH FACILITY – MRI AND RESEARCH LAB
DRINKO HALL - ROOM 249

Synopsis: Authorization to employ architect/engineering firms for the Thompson Library Renovation, Fry Hall Addition, Wilce Student Health Center Renovation – Phase 2, Graves Hall – ULAR Renovations, Pfahl Hall Executive Dining Room, Tzagournis Medical Research Facility – MRI and Research Lab, and Drinko Hall – Room 249 projects, employ construction managers for the Thompson Library Renovation project, and request construction bids for the Camera Center – Hospital Labs, Medical Center Central Chilled Water Expansion, Health Sciences Quadrangle, Davis Heart and Lung Institute – Basement, Wilce Student Health Center Renovation – Phase 2, Graves Hall – ULAR Renovations, Women's Field House Relocation, Davis Heart and Lung Institute – Room 089, Pfahl Hall Executive Dining Room, Tzagournis Medical Research Facility – MRI and Research Lab, Drinko Hall – Room 249 projects is requested.

WHEREAS the University desires to renovate and construct an addition to the Thompson Library, re-landscape a portion of the Oval, provide swing space during construction, and construct a new module to the Library Book Depository; and

WHEREAS the total conceptual project cost is \$99,000,000 in 2006 dollars, with funding anticipated by future capital appropriations (\$69,000,000 to \$79,000,000) and gifts to the University Libraries (\$20,000,000 to \$30,000,000); and

WHEREAS the University desires to renovate the Camera Center being leased by the University to use for physician and outpatient services; and

WHEREAS this is a relocation of the Community Ambulatory Care Center projects approved by the Board in May 1998 because the new location is programmatically better and will cost less to renovate than the other sites proposed; and

WHEREAS the total estimated project cost is \$10,000,000 and the total estimated construction cost is \$8,120,000, with funding provided by University Hospitals; and

**EMPLOYMENT OF ARCHITECTS/ENGINEERS,
EMPLOYMENT OF CONSTRUCTION MANAGER, AND
REQUEST FOR CONSTRUCTION BIDS (contd)**

WHEREAS the University desires to create the first phase of a future central chilled water plant for the Medical Center by increasing capacity in the chilled water plant and piping for the Ross Heart Hospital with the ability to link chiller plants together in the future; and

WHEREAS the total estimated project cost is \$4,397,700 and the total estimated construction cost is \$3,600,000, with funding provided by Ross Heart Hospital (\$1,569,725) and Health Sciences (\$2,827,975); and

WHEREAS the University desires to construct the Health Sciences Quadrangle as provided for in the South Campus District Plan; and

WHEREAS the total estimated project cost is \$2,903,575 and the total estimated construction cost is \$2,347,909, with funding provided by Ross Heart Hospital (\$1,413,225), Transportation and Parking Services (\$446,292), and Health Sciences (\$1,044,058); and

WHEREAS the University desires to construct a three-floor addition to Fry Hall to house additional clinical and office areas for patient-based research for the College of Optometry; and

WHEREAS the total conceptual project cost is \$8,100,000, with funding anticipated by the Board of Regents (\$1,000,000), future capital appropriations (\$3,600,000), National Institute of Health Grant (\$2,000,000), College of Optometry (\$1,500,000); and

WHEREAS University Hospitals desires to complete a portion of the basement shell space in the Davis Heart and Lung Institute to house five laboratories with associated offices and space for shared equipment; and

WHEREAS the total estimated project cost is \$1,163,625 and the total estimated construction cost is \$925,000, with funding provided by gifts to the College of Medicine and Public Health; and

WHEREAS University Hospitals desires to renovate space on the first and third floors of the Wilce Student Health Center to provide new Physical Therapy and Clinical Laboratory space; and

WHEREAS the total estimated project cost is \$1,113,360 and the total estimated construction cost is \$839,760, with funding provided by future University bond proceeds, with debt service paid from patient revenue; and

WHEREAS the University desires to renovate the Vivarium in Graves Hall for University Lab Animal Resources; and

WHEREAS the total estimated project cost is \$814,720 and the total estimated construction cost is \$667,698, with funding provided by the Board of Regents (\$189,443), National Institute of Health Grant (\$378,885), and the Office of Research (\$246,392); and

WHEREAS the University desires to relocate the Women's Field House from its current location south of Cunz Hall to east of Lincoln Tower for use as an educational classroom building with the existing grading conditions replicated and restoration of the exterior wood siding; and

WHEREAS the total estimated project cost is \$671,935 and the total estimated construction cost is \$595,835, with funding provided by the Department of Physical Facilities (\$654,935) and Student Affairs (\$17,000); and

WHEREAS the University desires to renovate a portion of the shell space in the lower level of the Davis Heart and Lung Institute to provide a wet lab space; and

WHEREAS the total estimated project cost is \$398,812 and the total estimated construction cost is \$328,240, with funding provided by gifts to Health Sciences; and

**EMPLOYMENT OF ARCHITECTS/ENGINEERS,
EMPLOYMENT OF CONSTRUCTION MANAGER, AND
REQUEST FOR CONSTRUCTION BIDS (contd)**

WHEREAS the University desires to renovate the present executive dining room in Pfahl Hall to provide an enhanced restaurant operation to complement and better meet the needs of the Blackwell Inn; and

WHEREAS the total estimated project cost is \$494,700 and the total estimated construction cost is \$417,500, with funding provided by Student Affairs; and

WHEREAS the University desires to remodel three rooms on the ground floor of the Tzagournis Medical Research Facility to house an MRI and related research lab; and

WHEREAS the total estimated project cost is \$312,270 and the total estimated construction cost is \$250,000, with funding by the College of Medicine and Public Health; and

WHEREAS the University desires to renovate and modernize the Moritz College of Law courtroom to accommodate contemporary modes of trial practice instruction and courtroom technology; and

WHEREAS the total estimated project cost is \$300,000 and the total estimated construction cost is \$250,000, with funding provided by the College of Law;

NOW THEREFORE

BE IT RESOLVED, That the Interim President and/or Senior Vice President for Business and Finance be authorized to select qualified architectural/engineering firms as necessary for the Thompson Library Renovation, Fry Hall Addition, Wilce Student Health Center Renovation – Phase 2, Graves Hall – ULAR Renovations, Pfahl Hall Executive Dining Room, Tzagournis Medical Research Facility – MRI and Research Lab, and Drinko Hall – Room 249 projects and that the fees for these services be negotiated between the firms selected and the University; and

BE IT FURTHER RESOLVED, That the Interim President and/or Senior Vice President for Business and Finance be authorized to select a qualified construction manager firm as necessary for the Thompson Library Renovation project and that the fees for these services be negotiated between the firm selected and the University; and

BE IT FURTHER RESOLVED, That the Interim President and/or Senior Vice President for Business and Finance be authorized to request construction bids for the Camera Center – Hospital Labs, Medical Center Central Chilled Water Expansion, Health Sciences Quadrangle, Davis Heart and Lung Institute – Basement, Wilce Student Health Center Renovation – Phase 2, Graves Hall – ULAR Renovations, Women’s Field House Relocation, Davis Heart and Lung Institute – Room 089, Pfahl Hall Executive Dining Room, Tzagournis Medical Research Facility – MRI and Research Lab, Drinko Hall – Room 249 projects in accordance with established University and State of Ohio procedures, and if satisfactory bids are received, to issue contracts with all actions to be reported to this Board at the appropriate time.

(See Appendix XVII for background information and maps, page 393.)

SALE OF REAL PROPERTY

Resolution No. 2003-35

1375 SOUTH HAMILTON ROAD
COLUMBUS, OHIO

Synopsis: Authorization for the sale of an undivided one-half interest in improved real property located at 1375 South Hamilton Road in Columbus, Ohio, is proposed.

WHEREAS the Board of Trustees of The Ohio State University is presented with the opportunity to sell an undivided one-half interest in the improved real property located at 1375 South Hamilton Road; and

WHEREAS the total property has an appraised value of \$200,000, and the purchaser, DeMarco, Inc., has agreed to purchase the property at a price of \$202,000; and

WHEREAS the appropriate University offices have determined that the sale of this property is in the best interest of the University; and

WHEREAS net proceeds from the sale of the property will be reinvested by the Endowment:

NOW THEREFORE

BE IT RESOLVED, That the President and/or the Senior Vice President for Business and Finance be authorized to sell the University's interest in the property at 1375 South Hamilton Road to DeMarco, Inc., at a total price of not less than \$202,000, upon such terms and conditions as are deemed to be in the best interest of the University.

(See Appendix XVIII for background material and map, page 419.)

Upon motion of Ms. Hendricks, seconded by Mr. McFerson, the Board of Trustees adopted the foregoing resolutions by unanimous roll call vote, cast by Messrs. Patterson, Sofia, Slane, McFerson, and Judge Duncan, Meses. Longaberger and Hendricks.

--0--

President Jennings:

I would also like to recommend to the Board the following resolutions:

NAMING OF BUILDING

Resolution No. 2003-36

Synopsis: Approval of the naming of the Ohio 4-H Center, soon to begin construction off Fred Taylor Drive at the intersection of Borror Drive, honoring the corporate generosity of Nationwide Enterprises and the Ohio Farm Bureau Federation is proposed.

WHEREAS Nationwide Enterprises has been a generous and longtime benefactor to The Ohio State University, its College of Food, Agricultural, and Environmental Sciences and, especially, the youth development programs of Ohio 4-H and the Ohio State University Extension; and

WHEREAS the Ohio Farm Bureau Federation has a long history of leadership development and training for young people and future leaders; and

WHEREAS both of these Ohio companies have an agribusiness heritage as corporate partners for over 75 years; and

NAMING OF BUILDING (contd)

WHEREAS both Nationwide Enterprises and the Ohio Farm Bureau Federation have made gifts and pledges which total approximately half of the cost of the new Ohio 4-H Center, making possible this new facility on the campus of The Ohio State University:

NOW THEREFORE

BE IT RESOLVED, That in accordance with paragraph (F) of bylaw 3335-1-08 of the Administrative Code, the Board of Trustees approves that the proposed 4-H Center be named "The Nationwide and Ohio Farm Bureau 4-H Center."

APPOINTMENT AND REAPPOINTMENT OF INVESTMENT MANAGERS

Resolution No. 2003-37

Synopsis: Approval of the Appointment and Reappointment of Investment Managers is proposed.

WHEREAS it is the policy of The Ohio State University to utilize the service of external Investment Managers to assist in the management of the University's Endowment Fund; and

WHEREAS the Investments Committee of the Board of Trustees periodically reviews the results obtained by the external Investment Managers and the amount of funds assigned to each of them; and

WHEREAS it is prudent investment policy to adjust the mix and amounts of money assigned to external Investment Managers as economic conditions and performance change; and

WHEREAS the number of external Investment Managers and the amount of funds assigned to them shall be determined by the Board of Trustees:

NOW THEREFORE

BE IT RESOLVED, That upon the recommendation of the Investments Committee of the Board of Trustees the following named external Investment Managers and the Office of the Treasurer shall be approved to manage Endowment Funds as follows:

<u>Large Cap Equity Managers</u>	<u>Market Value/ Commitment As of 7/31/02</u>	<u>Changes</u>	<u>Revised Allocation</u>
ABN AMRO	\$ 32,535,661	\$ --0--	\$ 32,535,661
Barclays S&P 500	170,437,734	--0--	170,437,734
Barclays Value Index	21,355,543	--0--	21,355,543
Nicholas Applegate Mid Cap	67,818,299	--0--	67,818,299
University Students	14,229,242	--0--	14,229,242
<u>Small Cap Equity Managers</u>			
Barclays Extended	\$122,980,568	\$ --0--	\$122,980,568
Meeder Financial	72,098,004	--0--	72,098,004
Nicholas Applegate Small Cap	22,265,599	--0--	22,265,599

APPOINTMENT AND REAPPOINTMENT OF INVESTMENT MANAGERS (contd)

<u>International Equity Managers</u>	Market Value/ Commitment As of 7/31/02	Changes	Revised Allocation
Barclays International	\$35,888,059	\$ --0--	35,888,059
Invesco Global Asset	18,121,924	--0--	18,121,924
Sit International	10,989,639	--0--	10,989,639
<u>Fixed Income Managers</u>			
Banc One	\$26,456,311	\$ --0--	26,456,311
Commonfund High Yield Bonds	13,819,894	--0--	13,819,894
Cypress Asset Management	24,931,305	--0--	24,931,305
Hughes Capital Management	15,671,921	--0--	15,671,921
Huntington Trust	32,122,979	--0--	32,122,979
MDL Capital Management	79,840,630	--0--	79,840,630
<u>Alternative Managers</u>			
Battelle Technology Fund	\$2,625,000	\$ --0--	2,625,000
CID Seed Fund	1,000,000	--0--	1,000,000
Commonfund Hedged Investors	--0--	15,000,000	15,000,000
Commonfund New Leaders	10,000,000	--0--	10,000,000
Commonfund Capital Partners	7,067,000	--0--	7,067,000
EDF Ventures Seed Fund	1,000,000	--0--	1,000,000
Mesirow Partnership Fund I	10,000,000	--0--	10,000,000
Ramius Fund	14,987,891	--0--	14,987,891

Upon motion of Mr. Sofia, seconded by Ms. Hendricks, the Board of Trustees adopted the foregoing resolutions by six affirmative votes, cast by Messrs. Sofia, Slane, McFerson, and Judge Duncan, Mses. Longaberger and Hendricks, and one abstention cast by Mr. Patterson.

--0--

PRESENTATION ON THE REGIONAL CAMPUS COMMISSION REPORT

Mr. Patterson:

One of the ongoing efforts this past year was the Regional Campus Commission, which Brit Kirwan had appointed, and it is a natural following to the Academic Plan. There was a lot of time spent on it. What was hoped to be done in a few months, took longer because it went into greater depth.

PRESENTATION ON THE REGIONAL CAMPUS COMMISSION REPORT (contd)

Mr. Patterson: (contd)

In various configurations, the Regional Campus Commission Report has been submitted to us and we have had numerous opportunities to go over it. It is before us today for approval, and I would ask Bobby or Randy Smith to add, perhaps, some brief comments that they may want to make.

Dr. Bobby D. Moser:

Thank you, Mr. Chairman. As the chairman just indicated, in June we brought the report to you and at that time it was not totally complete. We had all the recommendations down, but the report was not totally finalized at that time. Since then, there have been several things that have happened, but the recommendations have not changed. I know there was a Board retreat in August with the Board and the regional campus trustees and the recommendations were discussed and presented at that time.

What we have for you here today, is the what, who, and the when. The what is the recommendation, who is responsible for doing this, and when we're going to get it done. Randy --

Dr. W. Randy Smith:

At the top of the report that you have is an Executive Summary, which specifies three levels of recommendations, the action, and the timeline.

First, throughout this report there are two general recommendations that we hope will be pervasive throughout the University in the months ahead. That is to clearly specify why we have and why we need regional campuses. That is an activity that the Offices of Academic Affairs and Communications need to play out from this point forward. Something that our office needs to work on, Academic Affairs, is the system operations concept that is identified here. So those are pervasive recommendations throughout the report.

Second, there is a set of recommendations that relate to the mission and governance, and relate to admissions and enrollment that have been dealt with in considerable detail in recent months. These are activities that various offices, including the Office of Academic Affairs, and certainly the Board of Trustees itself, can deal with immediately. These are things that needed to be addressed and are now being brought forward in the report to be addressed.

Let me focus for a second on the longer-term recommendations. There is a set of activities related to students and student services. For example, these relate to housing and student services for those students on regional campuses, which really need to be developed now in a more detailed planning sense. So the regional campuses, OAA, Office of Business and Finance, and the Office of Student Affairs need to work on developing plans for those student services.

Faculty and curriculum – a dialogue needs to begin on the extent of the “One University” model that we identify here in this report. Any kind of modifications we need to make to it particularly with regard to any issues that have bubbled up in terms of variability that exists between and among departments with the “One University” model.

With regard to curriculum, the real issue here is the suggestion of a modest expansion in the degree programs that might be offered on the regional campuses. Here we are talking about a process that needs to play itself out over

PRESENTATION ON THE REGIONAL CAMPUS COMMISSION REPORT (contd)

Dr. Smith: (contd)

the months to ensure that those programs are the ones that we want to proceed with, and that the way we're going to offer them is clear.

And, finally, there is a set of issues related to co-location. I think one of the important points of this report is that it lays out what some of the issues we face with co-location are. As that discussion plays itself out in the months ahead – through the trustees, the Office of the President, and OAA – at least that backdrop document is there as a point of departure.

So these are the recommendations in three areas – general, short-term, and long-term -- and we have identified here offices that will be responsible for moving forward with them, and the timeline. That is as succinct as I can be with that.

Dr. Moser:

Thank you, Randy. Mr. Chairman, we think this report certainly contributes to the Academic Plan. This also helps us fulfill our land-grant mission by providing accessibility to students for this campus to have access to this University and accomplish their goal of getting a degree from The Ohio State University. Thank you.

Mr. Patterson:

Questions? Dan --

Mr. Slane:

I just want to express my appreciation to Randy. This was an enormous project and I thought he really did an outstanding job.

Mr. Patterson:

I would certainly concur. Randy had the challenge of bringing all of these reports together, as Karen knows, and melding it into one, involving a tremendous amount of time and effort. So thank you both and the Committee. There were a lot of hours spent on this one.

**ACCEPTANCE OF THE FINAL REPORT AND ENDORSEMENT
OF THE RECOMMENDATIONS OF THE PRESIDENTIAL COMMISSION
ON THE REGIONAL CAMPUSES**

Resolution No. 2003-38

WHEREAS The Ohio State University Regional Campuses play an important role in the mission of the University and are integral to all parts of the Academic Plan; and

WHEREAS the University President, in June 2001, established a Presidential Commission on the Regional Campuses to study their current characteristics and identify issues related to their future development; and

WHEREAS the Commission has completed a year-long study of the Regional Campuses that included data collection and review; site visits that provided input from Regional Campus faculty, students, staff, trustees, and administrators; and interviews with other universities that have regional campuses; and

**ACCEPTANCE OF THE FINAL REPORT AND ENDORSEMENT
OF THE RECOMMENDATIONS OF THE PRESIDENTIAL COMMISSION
ON THE REGIONAL CAMPUSES (contd)**

WHEREAS the Commission focused its recommendations on issues relating to mission and governance, admissions and enrollment, students and student services, and faculty and curriculum, and has identified a set of recommendations that can be implemented soon, and another set that will lead to further discussion and analysis within the University before adoption and implementation; and

WHEREAS the recommendations were presented at each Regional Campus (May 2002), to the University Senate (June 5, 2002), to The Ohio State University Board of Trustees (June 7, 2002), and to the Regional Campus Boards of Trustees (August 23, 2002):

NOW THEREFORE

BE IT RESOLVED, That the Board of Trustees accept the Final Report of the Presidential Commission on the Regional Campuses and endorse the recommendations and the plan for their implementation.

Upon motion of Ms. Hendricks, seconded by Mr. Sofia, the Board of Trustees adopted the foregoing resolution with six affirmative votes, cast by Messrs. Patterson, Sofia, Slane, McFerson, and Judge Duncan, and Ms. Hendricks, and one abstention cast by Ms. Longaberger.

(See Appendix XIX for Presidential Commission on the Regional Campuses, page 421.)

--0--

Thereupon the Board adjourned to meet Friday, October 4, 2002, at The Ohio State University Longaberger Alumni House, Columbus, Ohio.

Attest:

William J. Napier
Secretary

James F. Patterson
Chairman

The Importance of Faculty-Student Interaction

Eddie Pauline, President, Undergraduate Student Government

Joe Shultz, Member, Board of Trustees

September 6, 2002

Today, the Ohio State University is a different institution than it was ten or even five years ago. Academic standards for undergraduate admission have steadily improved. There is increasing focus by faculty on research while simultaneously handling their classroom and teaching responsibilities. If, however, we intend to live up to the premise of the Academic Plan, and to “create a rich educational environment for undergraduates,” the university should continue to expand on such initiatives as reducing class sizes and increasing class accessibility. Those improvements, however, if left isolated, cannot induce the kind of profound changes necessary to escalate the undergraduate experience. These most important, permanent, and lasting advances must stem from improving relations between faculty and students.

There are many reasons the university should prioritize examining and enhancing faculty/student interaction. First, as we observe the effects of selective admissions, it is abundantly clear that students will expect more services from the university, which will include more contact with faculty.

But perhaps the most important reason to make the issue of faculty/student interaction a priority is to facilitate an enhancement of community at Ohio State. It is, unfortunately, too easy for students, faculty, staff and the administration to exist independently of each other and to ignore the overarching bond that connects us all. We need to stress the value of community and be active participants in making our university one of the strongest societies of learning in the nation. Especially in light of budget restructuring, we find ourselves in the precarious position of allowing students to be seen merely as dollar signs for departments. We need to completely dispel that notion and work on coming together to collectively strengthen our university. Improving the quality of student and faculty interactions will be the catalyst for making Ohio State more than a superior research institution, but a place that truly teaches the value of community participation and engagement for generations to come.

Ways to build:

- **Encourage more regular faculty members to serve in intellectual advisory roles for students. In addition to faculty advising, strong support for staff members is also needed to ensure students’ needs are met in the areas of scheduling, career counseling and personal support.**
- **Increase the number regular faculty teaching undergraduate courses. Early interaction with faculty can inspire students and result in more serious learning.**
- **Invite and expect more students to participate in faculty-supervised research opportunities. This may inspire long-term commitments to research from undergraduates later on in their academic career.**
- **Involve more faculty members in the extracurricular student experience. Participation in student organizations, off campus activities and other aspects of the undergraduate student world outside of the classroom can be a great learning experience to both the faculty member and student.**

- Find a fair way to monitor and evaluate the quality of teaching, with an emphasis on dual learning taking place, to ensure that both faculty and students are communicating effectively.
- Encourage faculty and students to create a welcoming and interactive relationship.
- *All these desired ways to improve student/faculty interaction will require changes in the reward system. Until faculty colleagues and the administration persuade faculty that student/faculty interaction is to be valued more highly, little change will occur. The importance of improved student/faculty interaction can best be communicated through the reward system.*

In a very real sense, encouraging faculty/student interaction is an issue that is simply the right thing to do. But both students and the administration must be realistic in the awesome demand placed on faculty. For these ambitious expectations to become a reality, Ohio State must reward faculty for quality interaction with students both inside and outside the classroom. These rewards must come from the leadership of Ohio State in the form of pay, tenure, promotion, and recognition for faculty who demonstrate a commitment to quality undergraduate education.

We must also work diligently to improve the student desire to interact with faculty. Many probably have never had the inclination to learn more about their professors, and we must communicate the benefits of working closely with faculty to the student body. We feel if faculty initiated an effort to connect with students on a very personal level, it would spark a reciprocated effect that would increase the number of students who work and interact with faculty.

If strengthened, faculty-student interaction could have widespread benefits for our institution. Improved retention and graduation rates, higher quality learning, more committed alumni, would be a few of the indicators that our university is better serving the needs of students.

Ultimately, this formula will complement the mission of the Academic Plan and allow The Ohio State University to achieve its goal of becoming a world-class teaching and research institution.

**BYLAWS OF THE MEDICAL STAFF AND RULES & REGULATIONS
THE OHIO STATE UNIVERSITY HOSPITALS
Revisions – July 25, 2002**

IMPACT STATEMENT

AMENDMENTS

I. MEDICAL STAFF BYLAWS

- A. Amendments to reflect compliance with health information privacy standards (HIPAA).
- B. Clarification of provisions for return from leave of absence to assure clinical competency.
- C. Clarification of the privilege of dentists and oral and maxillofacial surgeons.
- D. Authorized the Medical Director to grant privileges to non-medical staff members in cases of medical emergencies, in order to benefit the public by maximal use of hospital facilities.
- E. Clarified telemedicine privileges.
- F. Specified that the Medical Staff Administrative Committee is empowered to act upon medical staff appointments and reappointments (without prior action by the credentials committee) when timely action is necessary.
- G. Deleted the necessity for two readings of bylaw amendments, enabling more timely action on amendments. Two-thirds vote of the Medical Staff Administrative Committee is still required.

II. MEDICAL STAFF RULES AND REGULATIONS

- A. Made changes to ensure uniform terminology and meet JCAHO standards.
- B. Addressed the requirement for identifying and providing care for patients with mental, emotional, and or substance problems, including protection of the patient as well as the staff.
- C. Clarified the necessity for providing for alternate medical coverage for all patients if the attending physician is unavailable.
- D. Added new language detailing medical consultations.
- E. Adopted and modified the Rules and Regulations to incorporate electronic orders and compute order entries.
- F. Revised provisions on autopsies.
- G. Clarified surgical case review requirements, recognized this as an official peer review activity.
- H. Made significant changes to the requirements for medical records, including the definition of a complete medical chart and its contents; definition and timeliness of the inpatient history and physical; procedure notes; birth certificate language; and discharge summary timeliness.

THE OHIO STATE UNIVERSITY HOSPITALS
BYLAWS OF THE MEDICAL STAFF AND RULES & REGULATIONS (contd)
Revisions – July 25, 2002

IMPACT STATEMENT (contd)

AMENDMENTS

- I. Added section on medical information confidentiality.
- J. Modified the provisions on medical record entries and their authentication.
- K. Removed the necessity for a second reading of Rules and Regulation changes in order to expedite amendments.

**AMENDMENTS TO THE BYLAWS OF THE MEDICAL STAFF &
RULES AND REGULATIONS OF THE OHIO STATE UNIVERSITY HOSPITALS (contd)**

Amended Bylaws of the Medical Staff

3335-43-04 Membership.

(A) through (D) unchanged.

(E) Procedure for appointment.

(1) through (5) unchanged.

(6) Completed applications shall be acted upon as follows:

(a) through (c) unchanged.

All applications shall be acted upon by the Ohio state university hospitals board within one hundred ~~fifty~~ twenty days of receipt of a completed application. These time periods are deemed guidelines only and do not create any right to have an application processed within these precise periods. These periods may be stayed or altered pending receipt and verification of further information requested from the applicant, or if the application is deemed incomplete at any time. If the procedural rights specified in rule 3335-43-06 of the Administrative Code are activated, the time requirements provided therein govern the continued processing of the application.

(7) and (8) unchanged.

(F) Procedure for reappointment.

(1) At least one hundred eighty days prior to the end of the fiscal year, or the end of the biennial period, the chief of the clinical department shall provide each medical staff member with an application for reappointment to the medical staff on forms prescribed by the medical staff administrative committee. The reappointment application shall include all information necessary to update and evaluate the qualifications of the medical staff member. The chief of the clinical department shall review the information available on each medical staff member, and the chief of the clinical department shall make recommendations regarding reappointment to the medical staff and for granting clinical privileges for the ensuing biennial period. The chief of the clinical department's recommendation shall be transmitted in writing along with the signed and completed reappointment forms to the medical director at least ninety days prior to the end of the fiscal year or biennial period. The terms of paragraphs (A), (B), (C), (D), (E)(1), and (E)(2) of this rule shall apply to all applicants for reappointment. ~~An application for reappointment must be submitted by a medical staff member following a leave of absence from the medical staff or from the faculty.~~ Only completed applications for reappointment shall be considered by the credentials committee. An application for reappointment is complete when all the information requested on the reappointment application form is provided, the reappointment form is signed by the applicant, and the information is verified. A completed reappointment application form must contain:

(a) through (k) unchanged.

(l) Verification of completion of annual educational requirement as set forth in the university integrity and HIPAA programs.

(2) through (7) unchanged.

**AMENDMENTS TO THE BYLAWS OF THE MEDICAL STAFF &
RULES AND REGULATIONS OF THE OHIO STATE UNIVERSITY HOSPITALS (contd)**

Amended Bylaws of the Medical Staff (contd)

(G) Resumption of clinical activities following leave of absence.

- (1) A member of the medical staff who takes a leave of absence for medical reasons has the duty to disclose to his or her chief of clinical department and the medical director any medical leave of absence that may potentially impact his or her ability to discharge his or her clinical and teaching responsibilities. Upon return from a leave of absence for medical reasons the medical staff member must demonstrate his or her ability to exercise his or her clinical privileges upon return to clinical activity. The credentials committee, the medical director, the chief of the clinical service or the medical staff administrative committee shall have the authority to require any documentation, including advice and consultation from the committee for physician health that might have a bearing on the medical staff member's ability to carry out the clinical and educational responsibilities for which the medical staff member is seeking privileges.
- (2) All members of the medical staff who take a leave of absence for medical or non-medical reasons must be in good standing on the medical staff upon resumption of clinical activities. The usual procedures for appointment and reappointment, including deadlines for submission of application as set forth in this rule, will apply irrespective of the nature of the leave.

3335-43-07 Categories of the medical staff.

The medical staff of the Ohio state university hospitals shall be divided into four categories: honorary medical staff; attending medical staff; courtesy medical staff; and limited staff.

(A) through (D) unchanged.

(E) Clinical privileges.

(1) through (4) unchanged.

(5) Dental privileges.

(a) Practitioners of dentistry, who have not been granted clinical privileges as oral and maxillofacial surgeons, may admit patients to the Ohio state university hospitals if such patients are being admitted solely to receive care which a dentist may provide without medical assistance, pursuant to the scope of the professional license of the dentist. Practitioners of dentistry must, in all other circumstances co-admit patients with a member of the medical staff who is a doctor of medicine or osteopathic medicine. A member of the medical staff who is a doctor of medicine or osteopathy shall be responsible for any medical problems that the patient has while an inpatient of the Ohio state university hospitals.

(b) A member of the medical staff who is a doctor of medicine or osteopathy:

- (i) Shall be responsible for any medical problems that the patient has while an inpatient of the Ohio state university hospitals; and
- (ii) Shall confirm the findings, conclusions and assessment of risk prior to high risk diagnosis or therapeutic interventions defined by the medical staff.

AMENDMENTS TO THE *BYLAWS OF THE MEDICAL STAFF & RULES AND REGULATIONS OF THE OHIO STATE UNIVERSITY HOSPITALS (contd)*

Amended Bylaws of the Medical Staff (contd)

(c) Practitioners of dentistry shall be responsible for the dental care of the patient including the dental history and physical examination and all appropriate elements of the patient's record.

(6) Oral and maxillofacial surgical privileges.

All patients admitted to the Ohio state university hospitals for oral and maxillofacial surgical care shall receive the same medical appraisal as all other hospitalized patients. Qualified oral and maxillofacial surgeons shall admit patients, shall be responsible for the plan of care for the patients, shall perform the medical history and physical examination, if they have such privileges, in order to assess the medical, surgical, and anesthetic risks of the proposed operative and other procedure(s), and shall be responsible for the medical care that may be required at the time of admission or that may arise during hospitalization.

~~(6)~~

(7) Other licensed health care professionals.

(a) Unchanged.

(b) A licensed health care professional as used herein, shall not be eligible for medical staff membership but shall be eligible to exercise those clinical privileges granted pursuant to these bylaws and in accordance with applicable Ohio state law. If granted such privileges under this rule and in accordance with applicable Ohio state law, other licensed health care professionals may perform all or part of the medical history and physical examination of a patient.

(c) Licensed health care professionals shall apply and re-apply for clinical privileges on forms prescribed by the medical staff administrative committee and shall be processed in the same manner as provided in rule 3335-43-04 of the Administrative Code subject to the provisions of paragraph (F)(6) of this rule.

~~(e)~~(d) Balance unchanged.

~~(e)~~(e) Balance unchanged.

~~(e)~~(f) Balance unchanged.

~~(f)~~(g) Balance unchanged.

~~(e)~~(h) Balance unchanged.

~~(h)~~(i) Balance unchanged.

~~(i)~~(j) Balance unchanged.

~~(j)~~(k) Balance unchanged.

~~(7)~~ (l) Balance unchanged.

**AMENDMENTS TO THE *BYLAWS OF THE MEDICAL STAFF &
RULES AND REGULATIONS OF THE OHIO STATE UNIVERSITY HOSPITALS (contd)***

Amended *Bylaws of the Medical Staff (contd)*

(8) Emergency privileges.

(a) Balance unchanged.

(b) Emergency privileges may be granted by the medical director or his or her designee to fully licensed, qualified individuals who at the time of the emergency are not members of the medical staff in order to provide voluntary services during a local, state, or national emergency in accordance with hospital/medical staff policy. The medical director may seek the recommendation of the chief of the clinical department. These privileges will be limited in scope and will terminate once the emergency situation subsides or at the discretion of the medical director.

(9) Telemedicine.

Telemedicine involves the use of electronic communication or other communication technologies to provide or support clinical care at a distance. Diagnosis and treatment of a patient may now be performed via telemedicine link.

(a) A member of the medical staff who wants to render care via telemedicine must so indicate on his or her application for clinical privileges.

(b) Generally, a member of the medical staff will be entitled to the same clinical privileges via telemedicine for which he has been granted privileges. The credentials committee, the chief of the clinical service, the medical director or the medical staff administrative committee shall have the prerogative of requiring documentation or making a determination of the appropriateness for the exercise of a particular specialty/sub-specialty via telemedicine.

3335-43-08 Organization of the medical staff.

(A) Unchanged.

(B) Names of clinical departments and divisions.

(1) through (3) unchanged.

(4) Internal medicine. The following divisions are designated:

- Allergy
- Cardiology
- ~~Clinical cancer genetics~~
- Community internal medicine
- Dermatology
- Endocrinology and metabolism
- Digestive diseases
- General medicine
- Hematology and oncology
- Human genetics
- Infectious diseases
- Nephrology
- Pulmonary
- Rheumatology - immunology

**AMENDMENTS TO THE BYLAWS OF THE MEDICAL STAFF &
RULES AND REGULATIONS OF THE OHIO STATE UNIVERSITY HOSPITALS (contd)**

Amended Bylaws of the Medical Staff (contd)

(5) through (13) Unchanged.

(14) Psychiatry. The following divisions are designated:

General psychiatry
Child psychiatry
~~Sleep disorders medicine~~
~~Geriatric psychology~~
Geriatric psychiatry
Health psychology

(15) through (17) unchanged.

(C) Unchanged.

(D) Qualifications and responsibilities of the chief of the clinical department.

The academic department chairperson shall ordinarily serve also as the chief of the clinical department. Each clinical department chief shall be qualified by education and experience appropriate to the discharge of the responsibilities of the position. Each clinical department chief must be board certified by an appropriate specialty board or must establish comparable competence. Such qualifications shall be judged by the respective dean of the college of medicine and public health or dentistry. Qualifications for chief of the clinical department generally shall include: recognized clinical competence, sound judgment and well-developed administrative skills.

(1) through (2) unchanged.

(3) Duties of the chief of the clinical department.

Each clinical department chief shall:

(a) through (h) unchanged.

(i) Hold monthly clinical department meetings. The agenda for the meetings shall include, but not be limited to a discussion of the clinical activities of the department. Minutes of departmental meetings, including a record of attendance, shall be kept in the clinical department and the medical director's office. ~~Greater than fifty per cent unexcused absence from department meetings may serve as the basis for a recommendation of non-reappointment to the medical staff.~~

(j) through (k) unchanged.

3335-43-10 Administration of the medical staff of the Ohio state university hospitals.

(A) through (B) unchanged.

(C) Medical staff administrative committee:

(1) Unchanged.

(2) Duties.

**AMENDMENTS TO THE *BYLAWS OF THE MEDICAL STAFF &
RULES AND REGULATIONS OF THE OHIO STATE UNIVERSITY HOSPITALS (contd)***

Amended *Bylaws of the Medical Staff (contd)*

(a) through (b) unchanged.

(c) To delegate appropriate staff business to committees while retaining the right of executive responsibility and authority over all medical staff committees. This shall include but is not limited to review of and action upon medical staff appointments and reappointments whenever timely action is necessary.

(d) through (n) unchanged.

(3) and (4) unchanged.

(D) through (H) unchanged.

(I) Medical records information management committee.

Balance unchanged.

3335-43-11 Meetings and dues.

(A) Meetings.

The medical staff of the Ohio state university hospitals shall conduct scheduled meetings twice yearly. Notice of the meeting shall be sent to all attending medical staff at least two weeks prior to the meeting. Attendance ~~at a minimum of one of the two regularly scheduled meetings is encouraged, but~~ shall not be a requirement for continued medical staff membership and clinical privileges. ~~Exceptions requested in writing in advance may be granted by the chief of staff, chief of staff-elect, or medical director. Unexcused absences shall be reported to the medical staff administrative committee.~~ Special meetings of the medical staff may be called at the option of the medical staff administrative committee.

(B) Unchanged.

3335-43-12 Amendments.

The bylaws committee shall review the bylaws and rules and regulations as need arises but not less than every two years. This committee shall recommend changes to the medical staff administrative committee.

These bylaws may be amended after notice is given at a meeting of the medical staff administrative committee. ~~Such notice shall be laid on the table until the next meeting~~ and shall require two-thirds vote of the members of the medical staff administrative committee present for approval and submission to the medical staff for ratification. Ratification of an amendment shall be by a plurality of those medical staff members voting through written ballot. When an amendment is approved by the medical staff administrative committee and ratified by the medical staff it shall be forwarded in successive order to the Ohio state university hospitals board which shall accept or reject the requested amendment. The amendment shall become effective when accepted by the board in the form ratified by the medical staff. Significant changes to these bylaws shall be reported in writing to the medical staff and other individuals who have clinical privileges. Neither the medical staff, nor the Ohio state university hospitals board may unilaterally amend these medical staff bylaws. (B/T 9/6/2002)

**AMENDMENTS TO THE BYLAWS OF THE MEDICAL STAFF &
RULES AND REGULATIONS OF THE OHIO STATE UNIVERSITY HOSPITALS (contd)**

Amended Medical Staff Rules and Regulations

84-02 Admission procedures.

(A) Except in an emergency, no patient shall be admitted to the hospital until after a provisional diagnosis has been stated by the patient's attending physician or by a member of the attending staff or a designee, in the interest of assignment to the appropriate service area. The request for admission shall also include the following information:

(1) Unchanged.

(2) Any information which ~~will~~ shall warn responsible hospital personnel of any tendency of any patient to try to commit suicide or to injure others because of mental disturbance.

(3) Unchanged.

(B) In the event that a patient is presented to the hospital with an illness, emotional problem, or condition which is the result of alcoholism or drug abuse and which substantially impairs the patient's affairs and social relationships (including indications of self-harm such as attempted suicide or suicidal gestures), it is the responsibility of the attending physician to provide for a proper comprehensive plan of care, including emergency care.

If a patient with a mental disorder is treated in the hospital for a medical condition, it shall be the responsibility of the attending physician to notify hospital or medical staff personnel of the existence of the mental or substance disorders and to order such precautionary measures as may be necessary to assure protection of the patient and the protection of others whenever a patient might be a source of danger.

It shall also be the attending physician's responsibility to address the underlying mental health or substance abuse problem and when indicated, refer the patient to an appropriate or dedicated facility dealing with alcoholism/drug abuse or mental health problems.

84-03 Attending assignment.

(A) All patients entering university hospitals who have not requested the services of a member of the medical staff of university hospitals to be responsible for their care and treatment while a patient therein shall be assigned to a member of the attending staff of the clinical division or service concerned with the treatment of the disease, injury, or condition which necessitated the admission of the patient to university hospitals. This shall also apply to the transfer of patients within the clinical divisions or services of the university hospitals.

(B) Alternate attending medical staff member coverage. Each member of the medical staff shall designate on his or her medical staff application one or more members of the attending or courtesy medical staff who have accepted this responsibility and who shall be called to attend his or her patients if the responsible attending medical staff member is not available. The chief of the medical staff member's clinical department, the medical director or his designee shall have authority to call any member of the medical staff should the attending medical staff member and the alternate be unavailable. If the chief of the medical staff member's department, the medical director or his designee is unavailable, the emergency department physician on duty is responsible for arranging appropriate medical coverage until the attending medical staff member is available to care for the patient.

**AMENDMENTS TO THE BYLAWS OF THE MEDICAL STAFF &
RULES AND REGULATIONS OF THE OHIO STATE UNIVERSITY HOSPITALS (contd)**

Amended Medical Staff Rules and Regulations (contd)

84-04 Consultations.

(A) Consultation requirements.

When the attending or courtesy medical staff member identifies in the course of treating the patient, a patient care problem that requires intervention during the hospital stay that is outside the medical staff member's area of training and experience, it is the responsibility of the attending or courtesy medical staff member to obtain consultation by the appropriate specialist.

(B) Responsibility to monitor consultations.

It is the duty of the medical staff through its clinical departmental chiefs and the medical staff administrative committee to assure that members of the staff comply in the matter of requesting consultations as needed.

(C) Consultation contents.

A satisfactory consultation shall be rendered within 24 hours of the request and shall include examination of the patient, examination of the medical record, and a written opinion signed by the consultant that is made a part of such record. If operative procedures are involved, the consultation note, except in an emergency, shall be recorded prior to the operation.

84-04 84-05 Order writing privileges Privileges for giving orders.

(A) "Definition of "Patient Orders patient orders."

A patient order(s) is a prescription for care or treatment of inpatients, outpatients or emergency patients, which is written, or dictated verbally, An order can be given verbally, electronically or in writing to qualified personnel identified by category in paragraph (C) of this rule, and signed shall be authenticated by a the licensed medical practitioner. Patient orders may be written given initially, renewed, discontinued or cancelled. Throughout these rules and regulations, the word "written" and its grammatical derivatives, as used to describe a non-verbal order, refer to both written and electronically entered orders.

(B) Electronic ordering.

Electronic orders are equivalent and have the same force as written orders. Electronic orders have been expressly structured to mirror these rules and regulations and all policy guidelines adopted by the medical staff and hospital administration.

~~(B)~~

(C) Responsible medical practitioner.

The licensed physician, dentist, or podiatrist (under medical doctor supervision), or psychologist (under medical doctor supervision) member of the medical staff responsible for the hospitalization or outpatient care, and treatment of the patient is responsible for all orders for the patient. Attending, courtesy, and honorary medical staff may designate members of the limited staff to write or electronically enter orders under their direction. The attending staff member may also designate members of the pre-M.D. medical student group to write or electronically enter orders, but in all cases the orders shall be signed by the physician,

**AMENDMENTS TO THE *BYLAWS OF THE MEDICAL STAFF &
RULES AND REGULATIONS OF THE OHIO STATE UNIVERSITY HOSPITALS (contd)***

Amended Medical Staff Rules and Regulations (contd)

dentist, podiatrist, psychologist, or designated limited staff member who has the right of practice of medicine, dentistry, psychology, or podiatry, and who is responsible for that patient's care. All ~~written non-verbal~~ orders must be ~~signed~~ authenticated by the medical practitioner prior to the execution of the order(s) by the hospital or outpatient nursing staff or other professional groups.

Patient orders written or electronically entered by "off-service" ~~house-officers~~ limited staff or consultant staff must be ~~countersigned~~ authenticated by the responsible practitioner or the practitioner's designee. Exception may be made in the event of preoperative orders or in the instance of acknowledged co-management; e.g. the intensive care unit or recovery room.

~~(C)~~

(D) Telephone and verbal orders.

Telephone and verbal orders may be given by the responsible attending physician, dentist, podiatrist, psychologist, or member of the limited ~~medical~~ staff only to health care providers who have been approved in writing by title or category by the medical director, the executive director of the hospitals, and each chief of the clinical service where they ~~will~~ shall exercise clinical privileges, and only where said health care provider is exercising clinical privileges which have been approved and delineated by job description for employees of the hospitals, or by the customary medical staff credentialing process when the provider is not an employee of the hospitals. Lists of the approval titles or categories of providers shall be maintained by the medical director. The job description or delineated privileges for each provider must indicate each provider's authority to receive telephone or verbal orders, including but not limited to the authority to receive orders for medications. The order is to be ~~written~~ recorded and ~~signed~~ authenticated by the approved health care provider to whom it is ~~dictated or given~~ as "verbal order by Dr.," or "V. O. or T. O. by Dr.," giving recording the medical practitioner's name and hour, ~~followed by the approved health care provider's signature~~ the time of the order. All telephone and verbal orders for D.E.A. schedule II controlled substances, patient seclusion, or patient restraint must be authenticated within one day by ~~signature of a~~ the licensed physician, dentist, podiatrist, psychologist or limited staff member. All other ~~inpatient~~ verbal and telephone orders must be authenticated within twenty-one days of discharge ~~by signature or visit~~ by a licensed physician, dentist, podiatrist, psychologist, or limited staff member. All other ~~outpatient verbal and telephone orders must be authenticated prior to or at the time of the next outpatient visit by signature of a licensed physician, dentist, podiatrist, or limited staff member.~~

~~(D)~~

(E) Standing orders.

Balance unchanged.

~~(E)~~

(F) Preprinted orders.

Balance unchanged.

~~(F)~~

(G) Investigational drug orders.

Balance unchanged.

**AMENDMENTS TO THE BYLAWS OF THE MEDICAL STAFF &
RULES AND REGULATIONS OF THE OHIO STATE UNIVERSITY HOSPITALS (contd)**

Amended Medical Staff Rules and Regulations (contd)

~~(G)~~

(H) Change of nursing service.

"Change of nursing service" means official and physical movement (transfer) of a patient from any permanent care unit to another with or without change in attending physician, dentist, psychologist, or podiatrist or clinical service. Orders effective before transfer must be renewed, ~~or rewritten~~ or reentered upon transfer by ~~signature of a the~~ responsible medical practitioner. The new or renewed orders may be written or electronically entered before or when the patient arrives on the receiving unit and may become effective immediately.

In each case of "change of nursing service," it is the responsibility of the receiving nurse to establish the availability of renewed or new written or electronically entered orders. Prior orders ~~will~~ shall remain in effect until new orders are available. This should be done within eight hours of transfer.

~~(H)~~

(I) Transfer of clinical service.

Transfer of clinical service means transfer of full patient responsibility from one attending physician, dentist, psychologist, or podiatrist to another; the patient may remain on the same unit or a "change of nursing service" may also occur. Admission of a patient from an emergency service to the hospital as an inpatient involves "transfer of clinical service."

For the purposes of ~~order~~ writing or electronically entering orders, two essentials of "transfer of clinical service" are necessary:

(1) Unchanged.

(2) Transfer of service may be completed only by the receiving service writing or electronically entering an order to the effect -- "accept in transfer (or admission) to Dr., cardiology service."

Orders effective before the transfer must be renewed, ~~or rewritten~~ or reentered upon transfer by ~~signature of a the~~ responsible medical practitioner. The new or renewed orders may be written or electronically entered before or at the time of transfer, and may become effective immediately. It is the responsibility of the receiving nurse to establish the availability of new or renewed orders. ~~if~~ If new orders are unavailable, then the nurse may continue previous orders and immediately notify the responsible medical practitioner.

~~(I)~~

(J) Patient orders and the "covering" medical practitioner.

Balance unchanged.

~~(J)~~

(K) Hospital discharge/readmission orders.

Hospital discharge from standard inpatient units or day care units to outpatient status requires appropriate discharge orders. Readmission to any inpatient unit requires new, rewritten/reentered or renewed orders by ~~signature of~~ the responsible medical practitioner.

**AMENDMENTS TO THE *BYLAWS OF THE MEDICAL STAFF &
RULES AND REGULATIONS OF THE OHIO STATE UNIVERSITY HOSPITALS (contd)***

Amended Medical Staff Rules and Regulations (contd)

~~(K)~~

(L) Orders in emergency vehicles.

Balance unchanged.

~~(L)~~

(M) Do not resuscitate order.

Do not resuscitate orders must be written or electronically entered in strict compliance with the comprehensive policy guidelines published by the medical staff administrative committee and hospital administration. See hospital procedure manual section 03-24.

84-05 ~~84-06~~ Death and autopsy procedures.

(A) Every member of the medical staff shall be actively interested in securing ~~necropsies~~ autopsies whenever possible. No ~~necropsy~~ autopsy shall be performed without written consent, permission, or direction as prescribed by the laws of Ohio.

(B) Unchanged.

(C) All autopsies shall be performed by an attending pathologist with hospital privileges or other attending practitioner who is qualified to perform autopsies. The attending pathologist or his or her designee shall have the responsibility of informing the patient's attending physician or designee that a proper consent for the performance of an autopsy has been obtained. The anticipated time for the autopsy shall also be reported at this time.

(D) Criteria for autopsy requests include the following:

(1) Coroner's cases when the coroner elects not to perform an autopsy. The county coroner has jurisdiction for performing an autopsy when death is the result of violence, casualty, or suicide, or occurs suddenly in a suspicious or unusual manner. Deaths occurring during surgery or within twenty-four hours of admission to the hospital are also coroner's cases, and the decision whether to autopsy is the coroner's responsibility. When the coroner elects not to perform an autopsy, a request for an autopsy shall be made pursuant to paragraph (A) of these rules and regulations.

(2) Unexpected or unexplained deaths, where apparently due to natural causes or due to those occurring during or following any surgical, medical, or dental diagnostic procedures or therapies.

(3) Undiagnosed infectious disease where results may be of value in treating close contacts.

(4) All deaths in which the cause of death is not known with certainty on clinical grounds.

(5) Cases where there is question of disease related to occupational exposure.

(6) Organ donors (to rule out neoplastic or infectious disease).

(7) Cases in which autopsy may help to allay the concerns of the family or public regarding the death and to provide assurance to them regarding the same.

**AMENDMENTS TO THE BYLAWS OF THE MEDICAL STAFF &
RULES AND REGULATIONS OF THE OHIO STATE UNIVERSITY HOSPITALS (contd)**

Amended Medical Staff Rules and Regulations (contd)

(8) Deaths in which autopsy may help to explain unknown or unanticipated medical complications to the attending.

(9) Deaths of patients who have participated in investigational therapy protocols.

(10) Deaths in which there is a need to enhance the education and knowledge of the medical staff and house staff. The attending practitioner shall be notified of the autopsies performed by the pathology department.

~~(C)~~

(E) When a necropsy an autopsy is performed, provisional anatomic diagnosis should be recorded in the medical record within three days and the complete protocol should be made a part of the record within ninety sixty days.

~~84-06~~ 84-07 Disaster plan.

Balance unchanged.

~~84-07~~ 84-08 Emergency care.

(A) through (C) unchanged.

(D) Policies.

Written policies concerning operation of emergency services ~~will~~ shall be developed by the medical director of the emergency department in consultation with appropriate services. These ~~will~~ shall be reviewed at least annually and approved by the medical staff or its representatives and the hospital administration. These ~~will~~ shall be revised as needed and dated at time of last review.

(E) Records.

Records ~~will~~ shall be maintained on all patients in accordance with the rules of the JCAHO for a level I service. The emergency record shall be incorporated into the permanent hospital record. All persons seeking care shall be identified in a control register.

~~84-08~~ 84-09 Surgical case review (~~tissue committees~~).

Surgical case review shall be performed as part of the hospital's peer review and quality improvement activity on an ongoing basis, at least monthly, by each department/division (as appropriate) regularly doing surgical procedures. The review shall include indications for surgery and all cases in which there is a major discrepancy between preoperative and postoperative (including pathologic) diagnoses. Discrepancies between the clinical impression and tissue removed during a surgical procedure are identified by pathology and then referred to the appropriate department performing surgical procedures for review. A screening mechanism based on predetermined criteria may be established for cases involving no specimens. Written records of the evaluations and any action taken shall be maintained in the clinical quality and resource management department operations improvement division, available to the medical director or the director's designee and the clinical department chairperson or their designee.

**AMENDMENTS TO THE *BYLAWS OF THE MEDICAL STAFF &
RULES AND REGULATIONS OF THE OHIO STATE UNIVERSITY HOSPITALS (contd)***

Amended Medical Staff Rules and Regulations (contd)

84-09 ~~84-10~~ Tissue disposition.

All tissue and foreign bodies removed during a surgical procedure shall be sent to the pathology laboratory for examination except for the following categories. These exceptions may be invoked by the attending surgeon only when the quality of care is not compromised by the exception, when another suitable means of verification of the removal is routinely employed, and when there is an authenticated operative or other official report that documents the removal. The categories of specimens that may be exempted from pathological examination are the following:

~~(A) Discrepancies between the clinical impression and tissue removed during a surgical procedure are identified by pathology and then referred to the appropriate surgical committee for review. Final disposition is made by the quality assurance committee.~~

~~(B)~~

(A) Balance unchanged.

~~(C)~~

(B) Balance unchanged.

~~(D)~~

(C) Balance unchanged.

~~(E)~~

(D) Balance unchanged.

~~(F)~~

(E) Balance unchanged.

~~(G)~~

(F) Balance unchanged.

~~(H)~~

(G) Balance unchanged.

84-10 ~~84-11~~ Committees and policy groups.

In addition to the medical staff committees, the medical staff shall participate in the following hospital ~~committees~~ and monitoring functions: infection control, clinical quality ~~and resource~~ management, safety, ~~and disaster planning~~, and in other leadership council advisory policy groups.

84-11 ~~84-12~~ Medical information management committee.

(A) The medical information management committee has representation from medical staff, nursing, medical ~~records~~ information management, and hospital administration. The committee shall meet at least quarterly and carry out the following duties:

(1) through (4) unchanged.

**AMENDMENTS TO THE *BYLAWS OF THE MEDICAL STAFF &
RULES AND REGULATIONS OF THE OHIO STATE UNIVERSITY HOSPITALS (contd)***

Amended Medical Staff Rules and Regulations (contd)

- (5) Submit recommendations to assure the maintenance of complete, accurate medical information for compliance with applicable policies and regulations of the clinical quality management committee, health system clinical computing information committee, governmental agencies, accrediting bodies, and purchasers of care.
- (6) and (7) unchanged.
- (8) Maintain written records of conclusions, recommendations, actions taken, and results of the actions taken, and report regularly to the clinical computing committee and make recommendations to the health system clinical information committee, clinical quality management committee or any other relevant committees that have a role in implementing policies adopted by the medical information management committee.
- (B) Each member of the medical staff shall conform to the policies established by the medical information management committee, including the following:
- (1) Chart contents.
- The attending medical staff member shall be responsible for the preparation of a complete medical record of each patient admitted to the hospital. This record shall include the following:
- (a) through (j) unchanged.
- ~~(k) Memorandum copy of the death certificate, when applicable.~~
- ~~(l)~~
- ~~(k)~~ Condition Discharge disposition, condition of patient at discharge, including and instructions given at that time.
- ~~(m)~~
- ~~(l)~~ Summary and final diagnosis as verified by the attending medical staff member's signature.
- ~~(n)~~
- ~~(m)~~ Documentation of informed consent.
- ~~(n)~~ Pre-sedation or pre-anesthesia assessment and plans of care for patients receiving anesthesia.
- ~~(o)~~ The legal status of patients receiving mental health services.
- ~~(p)~~ Emergency care provided to the patient prior to arrival, if any.
- ~~(q)~~ Evidence of known advance directives.
- ~~(r)~~ All reassessments and any revisions of the treatment plan.
- ~~(s)~~ Every medication ordered or prescribed on an inpatient.
- ~~(t)~~ Every medication dispensed to an inpatient at discharge.

**AMENDMENTS TO THE *BYLAWS OF THE MEDICAL STAFF &
RULES AND REGULATIONS OF THE OHIO STATE UNIVERSITY HOSPITALS (contd)***

Amended Medical Staff Rules and Regulations (contd)

- (u) Every dose of medication administered and any adverse drug reaction.
 - (v) Any referrals and communications made to external or internal providers and to community agencies.
 - (w) Postoperative documentation records, the patient's vital signs and level of consciousness; medications, including IV fluids, blood and blood components; any unusual events or postoperative complications; and management of such events.
 - (x) Postoperative documentation of the patient's discharge from the post-sedation or post-anesthesia care area by the responsible licensed independent practitioner or according to discharge criteria.
 - (y) An intra-operative anesthesia record.
 - (i) A post-anesthesia follow-up report written within forty-eight hours after surgery by the individual who administers the anesthesia.
 - (ii) Signed and dated reports of nuclear medicine interpretations, consultations, and procedures.
- (2) History and physical examination.
- (a) A complete history and physical examination shall be documented on all inpatient records. The history and physical shall include:
 - (i) Date of admission
 - (ii) Chief complaint
 - (iii) History of present illness
 - (iv) Past medical history
 - (v) Relevant past social and family history
 - (vi) Medications
 - (vii) Review of systems
 - (viii) Physical examination
 - (ix) Test results
 - (x) Impression
 - (xi) Plan of care
 - (b) A history and physical appropriate to the procedure and the patient shall be documented in the medical record of all ambulatory surgery patients, and patients undergoing outpatient procedures.

**AMENDMENTS TO THE *BYLAWS OF THE MEDICAL STAFF &
RULES AND REGULATIONS OF THE OHIO STATE UNIVERSITY HOSPITALS (contd)***

Amended Medical Staff Rules and Regulations (contd)

(c) A history and physical appropriate to the patient and the patient's chief complaint shall be documented in the medical record of all ambulatory patients.

~~(2)~~

(3) Deadlines and sanctions.

(a) A history and physical examination may be completed prior to admission, surgery or the patient's initial visit and accepted as part of the medical record if completed within thirty days preceding the admission, surgery, or visit. If the history and physical is completed greater than seven days but within thirty days of admission, notation shall be made in the history and physical to indicate review and any updates.

~~(a)~~

(b) The complete history and physical examination shall be dictated or written no later than 24 hours after admission of the patient.

If the history and physical examination ~~are~~ is dictated, a summary of pertinent findings must be recorded in the patient's chart within 24 hours after admission. ~~If a history and physical examination have been performed within 30 days before admission, a copy of the report may be used in the patient's medical record, provided any changes that have occurred are recorded.~~

A history and physical is performed on all patients, both inpatient and outpatient, regardless of whether the medical treatment or procedure is high or low risk. The history and physical examination must be performed by a member of the medical staff or his/her designee and be signed and dated. In the event the history and physical examination is performed by a physician extender, ~~they~~ it shall be countersigned by the responsible medical staff member.

~~(b)~~

(c) Unchanged.

~~(e)~~

(d) When the history and physical examination, including the results of indicated laboratory studies and x-rays and the staff admission progress notes, are not recorded in the chart before the time stated for a procedure, the procedure cannot proceed until the history, physical, and laboratory results are entered into the chart. In cases where such a delay would likely cause harm to the patient, this condition shall be entered into the chart by the attending medical staff member or designee, and the procedure may begin. When there is a disagreement concerning the urgency of the procedure, it ~~will~~ shall be adjudicated by the medical director or the medical director's designee.

~~(d)~~

(e) A procedure note shall be entered in the record by the responsible attending medical staff member or the medical staff member's designee immediately upon completion of an invasive procedure. ~~An operative/procedure report must be dictated immediately following the procedure.~~ Procedure notes must be written for any surgical or medical procedures, irrespective of their repetitive nature, which involve material risk to the patient. For any formal operative procedures a note shall include the pre-operative diagnosis, procedure, surgeon(s), resident(s), anesthesiologist(s), surgical service, type of anesthesia (general or local), complications, invasive lines either added or deleted, estimated blood loss, any pertinent information not included

**AMENDMENTS TO THE *BYLAWS OF THE MEDICAL STAFF &
RULES AND REGULATIONS OF THE OHIO STATE UNIVERSITY HOSPITALS (contd)***

Amended Medical Staff Rules and Regulations (contd)

on O.R./anesthesia record, and preliminary surgical findings, and an operative/procedure report must be dictated immediately following the procedure. ~~Where a formal operative/ procedure report must be dictated immediately following the procedure.~~ The transcribed operative/procedure report must be signed by the attending medical staff member. Any operative/procedure report not dictated by 10:00 a.m. the day following the procedure shall be deemed delinquent and the attending medical staff member responsible ~~will~~ shall lose operating/procedure room and medical staff privileges the following day. Affected medical staff members ~~will~~ shall receive telephone calls from the medical ~~record administrator~~ information management department indicating the delinquent operative/procedure reports.

~~(e)~~

(f) Unchanged.

~~(f)~~

(g) Unchanged.

~~(g)~~

(h) Birth certificates ~~and birth certificate work sheets~~ must be signed by the medical staff member who delivers the baby within ~~24 hours~~ one week of the ~~baby's birth completion of the certificate.~~ ~~Birth certificate work sheets must be signed by the attending medical staff member or the medical staff member's designee within 24 hours of the baby's birth.~~ Fetal death certificates and death certificates must be signed and the cause of death must be recorded by the medical staff member with a permanent Ohio license within 24 hours of death. Medical staff members who have incomplete certificates ~~will~~ shall have their clinical privileges suspended until all certificates are completed. A list of delinquent certificates, by medical staff members ~~will~~ shall be prepared and distributed on a ~~daily~~ weekly basis by the medical ~~records administrator~~ information management department. The medical staff member ~~will~~ shall be given three days written notice of intention to suspend clinical privileges.

~~(3)~~

(4) Discharges.

- (a) Patients shall be discharged only on written or electronically entered order of the responsible medical staff member. At the time of ordering the patient's discharge or at the time of the medical staff member's next visit to the hospital (if the attending medical staff member has authorized a member of the limited ~~medical~~ staff to sign the order of discharge), the attending medical staff member shall see that the record is complete. The attending medical staff member or his or her designee is responsible for verifying the principal diagnosis, secondary diagnoses principal procedure, and other significant invasive procedures in the medical record by the time of discharge. If a principal diagnosis cannot be determined in the absence of outstanding test results, the attending medical staff member or his or her designee must record a "provisional" principal diagnosis by the time of discharge.
- (b) The discharge summary for each patient must be dictated by the responsible attending medical staff member or the medical staff member's designee within three days of discharge for any patient stay of more than ~~48 hours~~ two days. A handwritten

**AMENDMENTS TO THE *BYLAWS OF THE MEDICAL STAFF &
RULES AND REGULATIONS OF THE OHIO STATE UNIVERSITY HOSPITALS (contd)***

Amended Medical Staff Rules and Regulations (contd)

or dictated discharge summary must be completed within seven days of discharge for any patient stay of ~~48 hours~~ two days or less. A dictated summary is required on all patients who expire, regardless of length of stay. A handwritten discharge note may be substituted for a dictated discharge summary for normal obstetric and newborn stays. The discharge summary must be signed by the responsible attending.

- (c) All medical records must be completed by the attending medical staff member or, when applicable, by the attending medical staff member's designee within 21 days of discharge of the patient. Attending medical staff members ~~will~~ shall be notified of the intent to suspend for all incomplete records that are available. Attending medical staff members ~~will~~ shall have their ~~medical staff~~ admitting and operative scheduling privileges suspended until all records are completed. A list of delinquent incomplete records, by attending medical staff members, ~~will~~ shall be prepared and distributed by the ~~medical records administrator~~ information management department once each week. If an attempt is made by the attending medical staff member, or the attending medical staff member's designee when applicable, to complete the record, and the record is not available, the record is shall not be counted against the attending medical staff member.
- (d) Records which are incomplete, ~~greater~~ more than twenty-one days ~~from~~ after discharge are defined as delinquent.

(5) Confidentiality.

Access to medical records is limited to use in the treatment of patients, research, and teaching. All medical staff members are required to maintain the confidentiality of medical records. Improper use or disclosure of patient information is subject to disciplinary action.

(6) Ownership.

Medical records of hospital-sponsored care are the property of the hospital and shall not be removed from the hospital's jurisdiction and safekeeping except in accordance with a court order, subpoena, or statute.

(4)

(7) Records storage and security.

All ~~patient's~~ patient records, pathological examinations, slides, ~~radiological films~~ radiologic images, photographic records, cardiographic records, laboratory reports, statistical evaluations, etc., are the property of the ~~university~~ hospitals and shall not be taken from ~~university~~ hospitals except on court order, duly filed with the medical record administrator or the hospital administration. The hospital administration may, under certain conditions, arrange for copies or reproductions of any element of the patients' records to be made. Such copies may be removed from the hospitals after the medical record administrator or the proper administrative authority has received a written receipt thereof. In the case of readmission of the patient, all previous records or copies thereof shall be available for the use of the attending medical staff member or other health care providers. ~~Under normal circumstances, the original hospital~~ Hospital records, pathological examinations, slides, ~~radiological films~~ radiologic images, etc., ~~will~~ shall be maintained by the hospital ~~for no less than five years~~. Microfilms, paper, electronic tape recordings, magnetic media, optical disks, and such other acceptable storage techniques

**AMENDMENTS TO THE *BYLAWS OF THE MEDICAL STAFF &
RULES AND REGULATIONS OF THE OHIO STATE UNIVERSITY HOSPITALS (contd)***

Amended Medical Staff Rules and Regulations (contd)

will ~~shall~~ be used to permanently maintain patients' patient records, following the above prescribed ~~five~~ years.

~~(5)~~

(8) Informed consent documentation.

Unchanged.

~~(6)~~

(9) Sterilization consent.

Prior to the performance of an operative procedure for the expressed purpose of sterilization of a (male or female) patient, the attending medical staff member ~~will~~ shall be responsible for the completion of the legal forms provided by the hospital and signed by the patient. Patients who are enrolled in the Medicaid program must have their forms signed at least 30 days prior to the procedure. Informed consent must also be obtained from one of the parents or the guardian of an unmarried minor.

~~(7)~~

(10) Criteria changes

The medical ~~records~~ information committee shall define the criteria for record completion with approval of the medical staff.

(11) Entries and authentication.

(a) Entries in medical record can only be made by staff authorized by the medical information management committee.

(b) All entries must be legible and complete and must be authenticated and dated promptly by the person, identified by name and discipline, who is responsible for ordering, providing, or evaluating the service furnished.

(c) The electronic signature of medical record documents requires a signing password. At the time the password is issued, the individual is required to sign a statement that she/he will be the only person using the password. This statement will be maintained in the department responsible for the electronic signature system.

~~(8)~~ Signature stamps.

(d) Signature stamps may be used by medical staff members only when there is a statement on file with the medical ~~records~~ information management department stating that the medical staff member maintains possession of the stamp and will be the only person who will use the stamp in the medical records. The use of the stamp may not be delegated by the medical staff member to any other person for the purpose of affixing a signature to an entry in the medical record. Signature stamps may not be used on physician orders.

~~84-12~~ 84-13 Operating room committee.

Balance unchanged.

**AMENDMENTS TO THE *BYLAWS OF THE MEDICAL STAFF &
RULES AND REGULATIONS OF THE OHIO STATE UNIVERSITY HOSPITALS (contd)***

Amended Medical Staff Rules and Regulations (contd)

~~84-13~~ 84-14 Pharmacy and therapeutics committee.

Balance unchanged.

~~84-14~~ 84-15 Transfusion and immunization committee.

Balance unchanged.

~~84-15~~ 84-16 Mechanism for changing rules and regulations.

(A) Unchanged.

(B) Proposals for amendment to the rules and regulations may be made by any member of the attending staff. Such proposals shall be referred to the medical staff bylaws committee for review. Notice ~~will~~ shall then be given at any meeting of the medical staff administrative committee ~~and this notice will be tabled until the next meeting.~~ Two-thirds vote of the members present ~~will~~ shall be required for adoption.

(C) Unchanged.

(D) Amendments so accepted shall become effective when approved by ~~the vice president for health sciences and presented to the Ohio state university hospitals' board.~~

(E) Unchanged.

~~84-16~~ 84-17 Adoption of the rules and regulations.

These rules and regulations shall be adopted by the ~~Medical Staff Administrative Committee~~ medical staff administrative committee and forwarded for approval in the same fashion as provided in Section ~~84-15~~ 84-16.

~~84-17~~ 84-18 Sanctions.

Unchanged.

**BYLAWS OF THE MEDICAL STAFF OF THE ARTHUR G. JAMES CANCER HOSPITAL AND
RICHARD J. SOLOVE RESEARCH INSTITUTE
Revisions – August 6, 2002**

IMPACT STATEMENT

AMENDMENTS

These revisions define and satisfy the requirements by JCAHO standards. Other revisions are designed to reflect current practice; changes required by the adoption of the CHRI Board Bylaws; and changes consistent with policies adopted at University Hospitals.

The most substantial changes involve:

1. Minor amendments to the procedures for appointment and reappointment. This reflects current practice. Timelines are stated in a cumulative fashion, the role of various officials is clarified, and action by the CHRI Board is final. Appointments no longer go to the OSU Trustees for approval, consistent with OSUH policies. This reduces the time to complete appointments and reappointments.

2. Consistent with JCAHO standards and identical to OSUH policies, a new section on informal review is added to encourage early intervention in medical staff member problems. These minor interventions do not constitute adverse actions and therefore do not force parties to use the lengthy due process procedures.

3. Due process is streamlined. The peer review committee replaces the former departmental investigative committee and the grievance committee is eliminated. This is identical to OSUH Medical Staff Bylaws.

4. The hearing procedures are completely revised to allow the appointment of a three member hearing committee to conduct the formal hearing, and to report within sixty days to the full MSAC.

5. Changes in the medical staff categories, including removing the limited staff from membership are reflective of JCAHO standards.

6. Additions also are made for leaves of absence, emergency privileges, and telemedicine.

7. Membership of the MSAC is revised to reflect current practice. Disease specific committees are deleted and delegates at large are reduced to two. Attendance at MSAC is required for each member as a minimum of two-thirds and proxies are permitted. Participation on medical staff committees is encouraged.

8. Editorial changes are made to reflect Legislative Services guidelines and use of consistent terminology.

THE MISSION OF THE JAMES

The Comprehensive Cancer Center-Arthur G. James Cancer Hospital and Richard J. Solove Research Institute is a national and international leader in research providing high quality patient care and educational programs for the benefit of the citizens of Ohio and beyond.

Through its highly qualified faculty and staff and their interdisciplinary activities, the Cancer Program is uniquely positioned to reduce morbidity and mortality from cancer by:

- ◆ Conducting basic and clinical research;
 - ◆ Facilitating and expediting the transfer of results from scientific investigation to quality patient care;
 - ◆ Providing high quality health services in detection, diagnosis, treatment and rehabilitation;
 - ◆ Contributing to the educational advancement of health professionals;
 - ◆ Increasing public awareness regarding cancer; and
 - ◆ Promoting public policy changes to improve prevention, detection and treatment of cancer.

The Cancer Program and other units of the Ohio state university work in partnership with other research centers, institutional providers of health services and health professionals to reduce the incidence of cancer and to provide effective treatment for patients with cancer.

**AMENDMENTS TO THE BYLAWS OF THE MEDICAL STAFF OF THE ARTHUR G. JAMES
CANCER HOSPITAL AND RICHARD J. SOLOVE RESEARCH INSTITUTE (contd)**

Amended Bylaws of the Medical Staff of The James

3335-111-01 Medical staff name.

The board of trustees of the Ohio state university, by official action, established "the Arthur G. James cancer hospital and Richard J. Solove research institute (CHRI)." The director of the CHRI serves as the chief executive and operating officer of the CHRI and in this capacity is accountable to the president and the board of trustees of the Ohio state university senior vice president for health sciences and vice president for health services and the board. Hereinafter, the term "director" shall mean the director of the CHRI; the abbreviation "CHRI" shall mean the Arthur G. James cancer hospital and Richard J. Solove research institute; the term "medical staff" shall refer to the medical staff of the cancer hospital and research institute. "The medical staff of the Arthur G. James cancer hospital and Richard J. Solove research institute" shall be the name of the hospital's medical staff organization. In accordance with rules 3335-109-1 through 3335-109-20 of the Administrative Code, the CHRI board has delegated to the medical staff of the CHRI the responsibility to prepare and recommend adoption of these bylaws. (B/T 9/1/93, B/T 2/5/99, B/T 9/6/2002)

3335-111-03 Patients.

(A) Unchanged.

(B) There shall be only one category or classification of patients in the CHRI, and those patients are the private patients of the medical staff under whose care they are admitted. Patients admitted to the CHRI who, prior to admission, have not requested or selected a member of the medical staff to attend them shall be assigned for their care and treatment to a member of the medical staff by the chief of the appropriate ~~CHRI~~ clinical service or the chief's designee.

(C) Unchanged. (B/T 9/1/93, B/T 12/6/96, B/T 12/3/99, B/T 9/6/2002)

3335-111-04 Membership.

(A) Qualifications.

(1) Unchanged.

(2) All members of the medical staff of the CHRI, except community oncologist attending staff and community associate staff, shall be members of the faculty of the Ohio state university college of medicine and public health, or in the case of dentists, of the Ohio state university college of dentistry, and shall be duly licensed. Only those allopathic and osteopathic physicians, dentists, oral surgeons, clinical psychologists, and podiatrists who can document their education, training, experience, competence, health status and judgement adequate to perform the privileges being requested, adherence to the ethics of their profession, dedication to educational and research goals including adherence to practice guidelines implemented by the medical staff, and ability to work with others with sufficient adequacy to assure ~~the board of trustees of the Ohio state university~~ that any patient treated by them at the CHRI will be given the highest quality of medical care shall be qualified for eligibility for membership on the medical staff of the CHRI. Except for community oncologist attending staff and community associate staff, CHRI medical staff members shall also hold appointments to the medical staff of the Ohio state university hospitals for consulting purposes.

**AMENDMENTS TO THE BYLAWS OF THE MEDICAL STAFF OF THE ARTHUR G. JAMES
CANCER HOSPITAL AND RICHARD J. SOLOVE RESEARCH INSTITUTE (contd)**

Amended Bylaws of the Medical Staff of The James (contd)

- (3) Unchanged.
- (4) Applicants for community oncology attending or community associate medical staff categories, practicing in a James CHRI unit at another hospital, must have and maintain clinical privileges and active medical staff membership at that hospital.
- (5) through (7) unchanged.
- (8) All patients admitted to the CHRI for oral and maxillofacial surgical care shall receive the same medical appraisal as all other hospitalized patients. Qualified oral and maxillofacial surgeons shall admit patients, shall be responsible for the plan of care for the patients, shall perform the medical history and physical examination, if they have such privileges, in order to assess the medical, surgical, and anesthetic risks of the proposed operative and other procedure(s), and shall be responsible for the medical care that may be required at the time of admission or that may arise during hospitalization. Practitioners of dentistry, who have not been granted privileges as oral and maxillofacial surgeons, may admit patients to the hospital if such patients are being admitted solely to receive care which a dentist may provide without medical assistance, pursuant to the scope of the professional license of the dentist. Practitioners of dentistry and/or podiatry must, in all other circumstances, co-admit patients with a physician member of the medical staff. A physician member of the medical staff will be responsible for any medical problems that the patient has while an inpatient of the hospital. The dentist is responsible to perform and document those parts of the history and physical related to dentistry.
- (B) Application for membership.
- Initial application for medical staff membership shall be made by the applicant to the director or designee on prescribed forms stating the qualifications and references of the applicant and giving an account of professional training and experience. Applications may be made only if the qualifications are fulfilled as outlined in paragraph (A) of this rule and ~~supported by signatures of recommendations are obtained within a reasonable time from the~~ chief of the CHRI section, chief of the clinical division and the appropriate academic department chairperson. See paragraph (E)(1) of rule 3335-111-07 of the Administrative Code for exceptions to signature requirements. It shall include written statements which commit the applicant to abide by the bylaws, rules and regulations of the medical staff, and the board of trustees of the Ohio state university. The application shall also contain a statement acknowledging that medical staff membership requires participation in and cooperation with the peer review processes of evaluating credentials, medical staff membership and clinical privileges, and that a condition for membership requires mutual covenants between all members of the medical staff to release one another from civil liability in these review processes as long as the peer review is not conducted in bad faith, with malice, or without reasonable effort to ascertain the accuracy of information being disclosed or relied upon.
- (C) and (D) unchanged.
- (E) Procedure for appointment.
- (1) The completed and signed application for membership on the medical staff shall be presented to the director or designee. Signing the application constitutes a consent to be interviewed in regard to the application, authorizes appropriate personnel within the CHRI to consult with members of the medical staffs of other hospitals with which the applicant has been or has attempted to be associated, and with others who may have information

**AMENDMENTS TO THE BYLAWS OF THE MEDICAL STAFF OF THE ARTHUR G. JAMES
CANCER HOSPITAL AND RICHARD J. SOLOVE RESEARCH INSTITUTE (contd)**

Amended Bylaws of the Medical Staff of The James (contd)

bearing on the applicant's competence, health status, character and ethical qualifications. The applicant also consents to inspection by CHRI personnel of all records and documents that may be material to the evaluation of professional qualifications and competence to carry out the clinical, medical, and educational privileges for which the applicant is applying as well as professional ethical qualifications for medical staff membership and further releases from any liability all representatives of the CHRI for acts performed concerning this process. The applicant has an affirmative duty to disclose any prior or current challenges to licensure, including voluntary and involuntary relinquishment of such licensure, any loss or limitations of membership in any professional organization, or loss or limitations of medical staff membership or privileges at any other hospital, including voluntary terminations, voluntary or involuntary relinquishment of board certification or DEA certificate, voluntary or involuntary cancellation of professional liability insurance and, at a minimum, final judgments or settlements in malpractice cases. Upon request of the medical staff administrative committee, the applicant will document physical and mental status with sufficient adequacy to demonstrate that any patient treated by the applicant will receive professional care of a generally recognized level of high quality and efficiency. The conditions of this paragraph shall be deemed continuing and may be applicable to issues of continued good standing as a member of the medical staff. Individuals in administrative positions who request medical staff membership or clinical privileges are subject to the same procedures as all other applicants for membership and privileges.

The application for medical staff membership and/or clinical privileges shall be deemed complete when the following documents and information are received by the director or designee; notice of faculty appointment, (except for community oncologist attending staff and community associate staff), completed and signed application, photograph attached, photostat of license, DEA certificate and board certification (including verification by a primary source), chief of CHRI section, chief of clinical division (if applicable) and academic department chairperson's ~~endorsements~~ recommendations, except as otherwise specified in these rules, three letters of recommendation or reference forms, at least one of which references the applicant's current health status, delineation of privileges form including, but not limited to, documentation of training and experience when privileges for laparoscopic procedures, sedation and/or use of lasers are requested, and malpractice insurance policy face sheet.

- (2) The director or designee will forward the application to the chairperson of the appropriate academic department for review and verification of faculty status. The director or designee will forward the application to the chief of each section to which the applicant is being appointed. The chairperson and the chief of section shall signify their approval recommendation on the signature page of the application.
- (3) ~~The~~ When application is complete, the credentials committee will be responsible for investigating and verifying the character, qualifications, and professional standing of the applicant and shall submit a report of those findings and recommendations to the medical staff administrative committee for action and recommendation to the CHRI board. The chairman of the credentials committee shall be responsible to see that each complete application is reviewed and processed within ninety days.

The ninety day time period is a guideline only and does not create any right to have an application processed within this precise period. This period may be stayed or altered pending receipt and verification of further information requested from the applicant, or if the application is deemed incomplete at any time. If the procedural rights specified in

**AMENDMENTS TO THE BYLAWS OF THE MEDICAL STAFF OF THE ARTHUR G. JAMES
CANCER HOSPITAL AND RICHARD J. SOLOVE RESEARCH INSTITUTE (contd)**

Amended Bylaws of the Medical Staff of The James (contd)

rule 3335-111-05 of the Administrative Code are activated, the time requirements provided therein govern the continued processing of the application.

- (4) The medical staff administrative committee (see paragraph (B) of rule 3335-111-10 of the Administrative Code) shall recommend to the director, the appropriate academic department chairperson, and the chief of the CHRI section that the application be accepted, further investigated, or rejected. The director will forward the candidate's qualifications, with recommendations to the Arthur G. James Cancer Hospital and Richard J. Solove Research Institute Board (~~hereafter hospital~~ herein CHRI board). Under certain circumstances, the application may be reviewed and approved by a designated subcommittee of the ~~hospital~~ CHRI board prior to presentation to the full board. ~~All applications receiving expedited approval shall be submitted to the hospital board for action at its next meeting.~~ Following approval by the ~~hospital~~ CHRI board or the designated subcommittee of the ~~hospital~~ CHRI board, the candidate is eligible to participate in patient care activities as defined on the approved clinical privilege form. In order for an applicant to be eligible for expedited approval by the subcommittee of the ~~hospital~~ CHRI board, the application must contain no significant prior unresolved malpractice actions, no reference problems, few prior hospital affiliations and no reports of disciplinary action, licensure restrictions, involuntary limitations on clinical privileges, medical staff membership or any type of competency issue. The expedited process is intended to streamline only the approval process. It does not modify the credentials verification process.
- (5) When the ~~hospital~~ CHRI board has acted, the director of medical affairs of the CHRI shall transmit the decision in writing to the applicant. The director of medical affairs shall also notify the chairperson of the appropriate academic department. ~~Recommendations of the hospital board shall be forwarded to the university board of trustees for approval.~~
- (F) Procedure for reappointment.
- (1) Unchanged.
- (2) The basis on which the chairperson of the academic department and the chiefs of the sections of the CHRI are to act in regard to the reappointment of a medical staff member and the clinical privileges to be granted upon such reappointment shall be a member's professional competence; clinical judgment; ethical conduct; current licensure, listing of CME units, fifty per cent of which shall relate to the applicant's clinical specialty and are consistent with the licensing requirements of the applicable state professional board and privileges requested; health status, including any reasonable evidence and/or health assessment that may be requested by the credentials committee, the medical staff administrative committee or committee on physician health; annual PPD test; participation in clinical research programs; participation in staff affairs including attendance at committees to which member has been appointed or elected; compliance with the bylaws, rules and regulations of the medical staff including quality assurance responsibilities, and the board of trustees of the Ohio state university; cooperation with CHRI personnel; relations with other physicians, other health professionals or other staff; professional attitude toward patients; clinical and technical skills as indicated in part by the results of monitoring and evaluation activities; adherence to the access and communication standards; and, fulfillment of responsibilities to the university and the public. Continued membership on the medical staff requires participation in the patient care activities of the CHRI. A staff member who fails to admit patients or engage in comparable patient care activities in the CHRI (as determined by the director of medical affairs)

**AMENDMENTS TO THE BYLAWS OF THE MEDICAL STAFF OF THE ARTHUR G. JAMES
CANCER HOSPITAL AND RICHARD J. SOLOVE RESEARCH INSTITUTE (contd)**

Amended Bylaws of the Medical Staff of The James (contd)

for the preceding year will not be ~~reappointed~~ eligible for reappointment to the medical staff. The candidate may reapply for membership on the medical staff by procedures set forth in this rule subject to the same provisions and probation as new applicants for membership.

- (3) When the medical staff administrative committee is notified of a recommendation not to reappoint or of ~~an adverse change in clinical privileges~~ a reduction, suspension or revocation of clinical privileges, they shall instruct the director to give the affected member written notice of the decision, the stated reason for the decision, and the member's right to a hearing pursuant to paragraphs (A) and (B) of rule 3335-111-06 of the Administrative Code. This notification and an opportunity to exhaust the administrative appeal process shall occur prior to the imposition of the proposed penalties unless the emergency provisions outlined in paragraph (D) of rule 3335-111-05 of the Administrative Code apply. The notice by the director shall be sent certified return receipt mail to the affected member's last known address as determined by university records.
- (4) If the affected member of the medical staff does not make a written request for a hearing to the director within ~~fourteen~~ thirty-one days after receipt of the adverse decision, it shall be deemed a waiver of the member's right to any review by the medical staff administrative committee to which the member might otherwise have been entitled on the matter. It also means that all other avenues of redress are also waived.
- (5) Unchanged.
- (6) The final action of the medical staff administrative committee regarding a reappointment decision will be communicated by the director, along with the recommendation of the ~~medical director of~~ of medical affairs, to the professional affairs committee of the ~~hospital~~ CHRI board, and thereafter to the ~~hospital~~ CHRI board. The ~~hospital~~ CHRI board shall make a final decision and instruct the director to notify the same parties as directed in paragraph (E)(5) of this rule. (B/T 9/1/93, B/T 3/3/95, B/T 4/3/96, B/T 12/6/96, B/T 9/1/99, B/T 12/3/99, B/T 6/2/2000, B/T 4/5/2002, B/T 9/6/2002)

3335-111-05 Corrective action.

(A) ~~Procedures~~ Informal review.

All medical staff members agree to cooperate in review activities that are solely intended to improve the quality of medical care provided to patients at the CHRI and by the individual medical staff member. Such activities may include the handling and informal review of complaints, including patient complaints, disagreements, questions of clinical competence, or conduct and variation in clinical practice identified by the clinical sections or divisions and medical staff committees. The resulting information from such activities shall be furnished to the applicable academic department chair and CHRI section chief. Upon review by the CHRI section chief, and with concurrence of the director of medical affairs, the review activity may result in consultation with the medical staff member, recommendations for educational actions or additional training, sharing of comparative data, monitoring, informal letters of reprimand or warning or other methods of guidance to the medical staff member to assist them in improving the quality of patient care outside of the mechanism for formal review in paragraph (B) of this rule. Such actions are not regarded as adverse, do not require reporting to any governmental or other agency, and do not invoke a right to any hearing. In

**AMENDMENTS TO THE BYLAWS OF THE MEDICAL STAFF OF THE ARTHUR G. JAMES
CANCER HOSPITAL AND RICHARD J. SOLOVE RESEARCH INSTITUTE (contd)**

Amended Bylaws of the Medical Staff of The James (contd)

each case under review, an initial written determination shall be made by the CHRI section chief and the director of medical affairs whether:

- (1) ~~Whenever the activities or professional conduct of a member of the medical staff of the CHRI violate the standards or aims of the medical staff or standards of professional conduct; is considered to be disruptive to the operation of the CHRI; violates the bylaws, rules and regulations of the medical staff, or the board of trustees of the Ohio state university, or the state or federal law, corrective action against such a medical staff member may be initiated by a chief of a CHRI section, chairperson of the appropriate academic department, the director of medical affairs, the director, an officer or member of the medical staff, the dean of the appropriate college, or any member of the hospital board. All requests for corrective action shall be in writing, shall be submitted to the director, and shall be supported by reference to the specific activities or conduct which constitute grounds for the requested action. The complaint warrants no further action;~~
- (2) ~~The director shall promptly notify the affected member of the medical staff, in a confidential manner, that a request for corrective action has been made, and inform the member of the specific activities or conduct which constitute grounds for the requested action. The director shall investigate the matter in whatever manner deemed appropriate. Whenever the director determines that further action is warranted and that corrective action could result, which action could involve a reduction, suspension or revocation of clinical privileges, the director shall refer the requests to the chief of the CHRI section in which the staff member has clinical privileges, who shall impanel the investigation committee. If the chief of the clinical section is the staff member charged, or has initiated the corrective action, the director shall designate a physician member of the administrative staff to fulfill the functions herein specified for said chief. The affected member of the medical staff shall be notified of the referral to the investigation committee, and be informed that these medical staff bylaws will govern all further proceedings. The director shall designate a physician member of the administrative staff to exercise any or all duties or responsibilities assigned to that member under these rules for implementing corrective action and appellate procedure only if: Informal review under this paragraph is warranted; or~~
 - (a) ~~That member is the medical staff member charged;~~
 - (b) ~~That member is responsible for having the charges brought against another medical staff member; or~~
 - (c) ~~There is an obvious conflict of interest.~~

~~If the director decides that no further action is warranted, the director will notify the person(s) who filed the request for corrective action and the member accused, in writing, that no further action will be taken.~~

- (3) ~~In the event an investigative committee is appointed, the committee will investigate the request for corrective action and shall report within two weeks its findings and recommendations for action to the chief of the CHRI section or the director's designee. The chief of the CHRI section or the director's designee will forward the recommendation and the findings and recommendations of the investigation committee to the chairperson of the appropriate academic department and to the director. Prior to making such a report to the respective chairperson and director, the medical staff member against whom the corrective action has been requested shall have an opportunity to interview the chief~~

**AMENDMENTS TO THE BYLAWS OF THE MEDICAL STAFF OF THE ARTHUR G. JAMES
CANCER HOSPITAL AND RICHARD J. SOLOVE RESEARCH INSTITUTE (contd)**

Amended Bylaws of the Medical Staff of The James (contd)

~~of the CHRI section or the director's designee. At such interview, the medical staff member shall be informed of the specific activities alleged to constitute grounds for corrective action, and of the specific evidence which the investigation committee and the chief of the CHRI section or the director's designee have discovered which is material to the charge. The medical staff member shall be invited to discuss, explain, or refute the charge or the evidence thus far adduced. The medical staff member may furnish written or oral information at this time. However, such interview shall not constitute a hearing, but shall be investigative in nature. The medical staff member shall not be represented by an attorney at this interview. Peer review under paragraph (B) of this rule is warranted. In cases where the CHRI section chief and director of medical affairs cannot agree, the matter shall be submitted and determined as set forth in paragraph (B) of this rule. The CHRI section chief and the director of medical affairs shall determine whether it is appropriate to include documentation of such actions in the medical staff member's file. If documentation is included in the member's file, the affected member shall have an opportunity to review it and may make a written response which shall also be placed in the member's file.~~

- ~~(4) Following receipt by the director of the report from the investigation committee and the chief of the CHRI section, the director shall decide whether the grounds for the requested corrective action are such as could involve a reduction, suspension, or revocation of clinical privileges. If the director decides that the grounds are not substantiated, the director will notify the investigation committee; chief of the CHRI section; chairperson of the appropriate academic department; person(s) who filed the charge; and the medical staff member affected, in writing, that no further action will be taken. If the director decides that the grounds for corrective action are substantiated, the director shall impanel a grievance committee of the medical staff as outlined in paragraph (C) of this rule. The affected member of the medical staff shall be promptly notified by the director and permitted to make an appearance before the grievance committee of the medical staff. The rules of conduct of the meeting shall be as outlined in paragraph (C) of this rule. The grievance committee will forward its findings and recommendations for action to the director, the chairperson of the appropriate academic department, and the accused member of the medical staff.~~
- ~~(5) Following receipt by the director of the report from the grievance committee, the director shall decide whether the grounds for the requested corrective action are such as could involve a reduction, suspension, or revocation of clinical privileges. If the director decides the grounds are not substantiated, the director will notify the grievance committee, the person(s) who filed the charge and the medical staff member affected in writing that no further action will be taken. In the event the director finds the grounds for the requested corrective action are substantiated he or she may accept, reject, or modify the corrective action recommended by the grievance committee and notify the medical staff member of the director's decision and of the affected medical staff member's appeal rights pursuant to rule 3335-111-06 of the Administrative Code. This notification and an opportunity to exhaust the administrative appeal process shall occur prior to the imposition of the proposed penalties unless the emergency provisions outlined in paragraph (D) of this rule apply. This notice by the director shall be sent certified return receipt mail to the affected member's last known address as determined by university records.~~
- ~~(6) If the affected member of the medical staff does not make a written request for a hearing to the director within fourteen days after receipt of the adverse decision, it shall be deemed a waiver of the member's right to any review by the medical staff administrative committee to which the member might otherwise have been entitled on the matter.~~

**AMENDMENTS TO THE BYLAWS OF THE MEDICAL STAFF OF THE ARTHUR G. JAMES
CANCER HOSPITAL AND RICHARD J. SOLOVE RESEARCH INSTITUTE (contd)**

Amended Bylaws of the Medical Staff of The James (contd)

- (7) ~~If a timely, written request for hearing is made, the procedures set forth in rule 3335-111-06 of the Administrative Code shall apply.~~
- (B) Composition of the investigation committee Peer review.

(1) ~~At the beginning of the fiscal year, the chairperson of the academic department, in consultation with the director, shall select attending members of the department to serve on the standing investigation committee of that department. All members except one shall be designated permanent members and one shall serve as an alternate. The committee will also include a member of the attending staff from other services who is selected by the chairperson, in consultation with the director. The director or the director's designee shall also serve on the investigation committee. Peer review may be requested in more serious situations or where informal review has not resolved an issue or whenever the activities or professional conduct of a member of the medical staff of the CHRI:~~

- (a) Violates the standards or aims of the medical staff or standards of professional conduct;
- (b) Is considered to be disruptive to the operation of the CHRI;
- (c) Violates the bylaws, rules and regulations of the medical staff, the CHRI board, or the board of trustees of the Ohio state university;
- (d) Violates state or federal law; or
- (e) Is detrimental to patient safety or to the delivery of patient care within the CHRI.

Peer review may be initiated by a department chair, the CHRI section chief, the director of medical affairs, any member of the medical staff, the director of the CHRI, the dean of the college of medicine and public health, any member of the CHRI board, or the vice president for health services. All requests for peer review shall be in writing, shall be submitted to the director of medical affairs, and shall be supported by reference to the specific activities or conduct which constitute grounds for the requested action.

- (2) ~~The investigation committee, when called into session by the chairperson of the academic department, shall consist of three members of the medical staff. The alternate shall attend all meetings. When necessary, additional alternates may be selected. The director of medical affairs shall promptly notify the affected member of the medical staff, in a confidential manner, that a request for peer review has been made, and inform the member of the specific activities or conduct which constitute grounds for the requested action. The director of medical affairs shall verify the facts related to the request for peer review, and within thirty days, make a written determination. If the director of medical affairs decides that no further action is warranted, the director of medical affairs shall notify the person(s) who filed the request for peer review and the member accused, in writing, that no further action would be taken.~~
- (3) Whenever the director of medical affairs determines that peer review is warranted and that a reduction, suspension or revocation of clinical privileges could result, the director of medical affairs shall refer the request for peer review to the peer review committee. The affected member of the medical staff shall be notified of the referral to the peer review committee, and be informed that these medical staff bylaws shall govern all further proceedings. The senior vice president for health sciences or designee shall exercise any

**AMENDMENTS TO THE BYLAWS OF THE MEDICAL STAFF OF THE ARTHUR G. JAMES
CANCER HOSPITAL AND RICHARD J. SOLOVE RESEARCH INSTITUTE (contd)**

Amended Bylaws of the Medical Staff of The James (contd)

or all duties or responsibilities assigned to the director of medical affairs under these rules for implementing corrective action and appellate procedure only if:

- (a) The director of medical affairs is the medical staff member charged;
 - (b) The director of medical affairs is responsible for having the charges brought against another medical staff member; or
 - (c) There is an obvious conflict of interest.
- (4) The peer review committee shall investigate every request and shall report in writing within thirty days its findings and recommendations for action to the appropriate academic department chairperson and CHRI section chief. In making its recommendation the peer review committee may consider as appropriate, relevant literature and clinical practice guidelines, all the opinions and views expressed throughout the review process, and any information or explanations provided by the member under review. Prior to making its report, the medical staff member against whom the action has been requested shall be afforded an opportunity for an interview with the peer review committee. At such interview, the medical staff member shall be informed of the specific activities alleged to constitute grounds for peer review, and shall be afforded the opportunity to discuss, explain or refute the allegations against the medical staff member. The medical staff member may furnish written or oral information to the peer review committee at this time. However, such interview shall not constitute a hearing, but shall be investigative in nature. The medical staff member shall not be represented by an attorney at this interview.
- (5) Upon receipt of the written report from the peer review committee, the appropriate academic department chairperson shall, within seven days, make his or her own written determination and forward that determination along with the findings and recommendations of the peer review committee to the director of medical affairs, or if required by paragraph (B)(3) of this rule, to the senior vice president for health sciences or designee.
- (6) Following receipt of the recommendation from the academic department chairperson and the report from the peer review committee, the director of medical affairs, or the senior vice president for health sciences or designee, shall have ten days to approve or to modify the determination of the academic department chairperson. Following receipt of the report of the academic department chairperson, the director of medical affairs or senior vice president for health sciences or designee shall decide whether the grounds for the requested corrective action are such as should result in a reduction, suspension or revocation of clinical privileges. If the director of medical affairs, or senior vice president for health sciences or designee, decides the grounds are not substantiated, the director of medical affairs will notify the peer review committee; department chairperson; CHRI section chief; person(s) who filed the complaint and the affected medical staff member, in writing, that no further action will be taken.

In the event the director of medical affairs or senior vice president for health sciences or designee finds the grounds for the requested corrective action are substantiated, the director of medical affairs shall promptly notify the affected medical staff member of that decision and of the affected medical staff member's right to request a hearing before the medical staff administrative committee pursuant to rule 3335-111-06 of the Administrative Code. The written notice shall also include a statement that the medical staff member's failure to request a hearing in the timeframe prescribed in rule 3335-111-06 of the

**AMENDMENTS TO THE BYLAWS OF THE MEDICAL STAFF OF THE ARTHUR G. JAMES
CANCER HOSPITAL AND RICHARD J. SOLOVE RESEARCH INSTITUTE (contd)**

Amended Bylaws of the Medical Staff of The James (contd)

Administrative Code shall constitute a waiver of rights to a hearing and to an appeal on the matter; a statement that the affected medical staff member shall have the procedural rights found in rule 3335-111-06 of the Administrative Code; and a copy of the rule 3335-111-06 of the Administrative Code. This notification and an opportunity to exhaust the administrative hearing and appeal process shall occur prior to the imposition of the proposed corrective action unless the emergency provisions outlined in paragraph (D) of this rule apply. This written notice by the director of medical affairs shall be sent certified return receipt mail to the affected medical staff member's last known address as determined by university records.

- (7) If the affected member of the medical staff does not make a written request for a hearing to the director of medical affairs within thirty-one days after receipt of the adverse decision, it shall be deemed a waiver of the right to any review by the medical staff administrative committee to which the staff member might otherwise have been entitled on the matter.
- (8) If a timely, written request for hearing is made, the procedures set forth in rule 3335-111-06 of the Administrative Code shall apply.

(C) Composition of the grievance peer review committee.

- (1) At the first meeting of the medical staff, during the fall quarter of each academic year, the chief of the medical staff shall submit, for approval by the staff, the names of members of the attending staff who shall not be members of the medical staff administrative committee whom the chief has chosen as being appropriate to sit on the grievance committee when they are selected, by lot, to do so. When the determination that peer review is warranted is made, the CHRI section chief shall select three members of the medical staff to serve on a peer review committee.
- (2) The grievance committee, when called into session by the chief of staff, shall consist of five members of the staff whose names have been chosen by lot from the aforementioned list of members chosen. Once empanelled, the grievance committee shall conduct a meeting within one month and shall submit a report of its findings to the director within three months of the initial hearing. If the director does not receive a timely report from the grievance committee, the director may elect to forward the matter to the medical staff administrative committee for action without the benefit of a grievance committee report. No person shall be eligible for selection to serve on two successive grievance committees. The chief of the medical staff shall have authority to rule upon alleged conflicts of interest or disqualifications involving grievance committee members. Whenever the questions raised concern the clinical competence of the member under review, the CHRI section chief shall select members of the medical staff to serve on the peer review committee who shall have similar levels of training and qualifications as the member who is subject to peer review.
- (3) Each grievance committee shall choose from among its members a chairperson who shall preside over it and, with the advice and consent of the committee, speak for it, during the hearing, rule on matters relevant to its proceedings, and arrange for the conduct of the committee's administration. All grievance committee members shall be required to hear all evidence presented. Any recommendations that involve a reduction, suspension, or revocation of clinical privileges may be made by majority decision of the committee. If circumstances make attendance by a member of the grievance committee at a hearing impossible, or require an excessive postponement, the chief of staff shall

**AMENDMENTS TO THE BYLAWS OF THE MEDICAL STAFF OF THE ARTHUR G. JAMES
CANCER HOSPITAL AND RICHARD J. SOLOVE RESEARCH INSTITUTE (contd)**

Amended Bylaws of the Medical Staff of The James (contd)

~~order the remaining four to act upon a clear majority, or shall immediately select a new grievance committee. If more than one member cannot hear all of the evidence, a new committee shall be composed. An outside review consultant may serve as a member of the peer review whenever:~~

- ~~(a) A determination is made by the CHRI section chief and the director of medical affairs that the clinical expertise needed to conduct the review is not available on the medical staff;~~
- ~~(b) The objectivity of the review may be compromised due to economic considerations;
or~~
- ~~(c) Whenever the director of medical affairs determines that an outside review is otherwise advisable.~~

~~If an outside reviewer is recommended, the CHRI section chief shall make a written recommendation to the director of medical affairs for selection of an outside reviewer. The director of medical affairs shall make the final selection of an outside reviewer.~~

- ~~(4) The affected medical staff member shall have the right to personally appear before the grievance committee, to cross-examine the witnesses, and to submit to the grievance committee written evidence and memoranda relevant to the issues. The staff member shall be fully apprised of all allegations and all evidence known to the grievance committee, and shall be entitled to discuss, explain and refute all evidence adduced against the member. The affected medical staff member shall not be represented by an attorney before the grievance committee.~~

(D) Summary suspension.

- (1) Notwithstanding the provisions of this rule, a member of the medical staff shall have all or any portion of clinical privileges immediately suspended or appointment terminated by the director, in consultation with the chief of the member's CHRI ~~service, section and the director of medical affairs, or the senior vice president for health sciences and dean of the college of medicine and public health,~~ whenever such action must be taken in the best interest of patient care. Such summary suspension shall become effective immediately upon imposition and the medical staff member will be subsequently notified in writing of the suspension by the director. Such notice shall be by certified receipt return mail to the affected medical staff member's last known address as determined by university records.
- (2) A medical staff member whose privileges have been summarily suspended or whose appointment has been terminated shall be entitled to appeal the suspension pursuant to rule 3335-111-06 of the Administrative Code. If the affected member of the medical staff does not make a written request for a hearing to the director within ~~fourteen~~ thirty-one days after receipt of the adverse decision, it shall be deemed a waiver of the affected member's right to any review by the medical staff administrative committee of which the member might otherwise been entitled. If a timely, written request for a hearing is made, the procedures set forth in rule 3335-111-06 of the Administrative Code shall apply.

- (3) Unchanged.

(E) Unchanged.

**AMENDMENTS TO THE BYLAWS OF THE MEDICAL STAFF OF THE ARTHUR G. JAMES
CANCER HOSPITAL AND RICHARD J. SOLOVE RESEARCH INSTITUTE (contd)**

Amended Bylaws of the Medical Staff of The James (contd)

3335-111-06 Hearing and appellate review procedure.

(A) Right to hearing before the medical staff administrative committee and to appellate review.

(1) When a member of the medical staff has exhausted remedies under paragraph (F) of rule 3335-111-04 of the Administrative Code on reappointments; or under rule 3335-111-05 of the Administrative Code for corrective action; or who has been summarily or automatically suspended under paragraph (D) or (E) of rule 3335-111-05 of the Administrative Code receives notice of a proposed action by the director or the director of medical affairs that will adversely affect reappointment as a member of the medical staff or the exercise of clinical privileges, the staff member shall be entitled to a an adjudicatory hearing before the medical staff administrative committee which will submit a written report, including its recommendations, to the board of trustees by way of the executive committee within seven days of the conclusion of hearing evidence.

(2) Unchanged.

(B) Request for hearing.

(1) The request for a hearing ~~before the medical staff administrative committee~~ shall be submitted in writing by the affected medical staff member to the director within ~~fourteen~~ thirty-one days of notifications by the director of the intended action. The director shall forward the request to the medical staff administrative committee along with instructions to convene a hearing.

(2) The failure of a medical staff member to request a hearing ~~before the medical staff administrative committee~~, to which the member is entitled by these bylaws within the time and in the manner herein provided, shall be deemed a waiver of the member's right to any review by the medical staff administrative committee to which the member might otherwise been entitled. The director shall then implement the decision and that action shall become and remain effective against the medical staff member in the same manner as a final decision of the CHRI board of trustees of the Ohio state university as provided for in paragraph ~~(F)~~ (E) of this rule. The director shall promptly inform the affected medical staff member that the proposed decision which had entitled the medical staff member to a hearing has now become final.

(C) Notice of hearing.

(1) ~~Within fourteen days after~~ After receipt of a timely request for hearing by the director from a medical staff member entitled to the ~~same~~ such hearing, the medical staff administrative committee shall ~~schedule and arrange for such a hearing and shall, through the director, notify the medical staff member in writing of the time, place, and date so scheduled. The medical staff member shall be given at least ten days prior notice of the scheduled hearing, provided that this notice may be waived in writing by the medical staff member. Notice shall be by certified return receipt mail to the staff member at the member's last known address as reflected by university records. The hearing or the initial hearing, should more than one hearing be required, shall not be less than fourteen days nor more than thirty days from the date of the receipt of the request for hearing by the director; provided, however, that a hearing for a medical staff member who is under suspension, which is then in effect, shall be held as soon as arrangements may be reasonably made.~~ be notified of the request for hearing by the director, and shall at the next scheduled meeting take the following action:

**AMENDMENTS TO THE BYLAWS OF THE MEDICAL STAFF OF THE ARTHUR G. JAMES
CANCER HOSPITAL AND RICHARD J. SOLOVE RESEARCH INSTITUTE (contd)**

Amended Bylaws of the Medical Staff of The James (contd)

- (a) Instruct the director of medical affairs and chief of staff to jointly appoint within seven days a hearing committee, consisting of three members of the medical staff who are not members of the medical staff administrative committee, are not direct competitors, do not have a conflict of interest, and who have not previously participated in the peer review of the matter under consideration.
- (b) Instruct the hearing committee to schedule and arrange for a hearing or hearings which initial hearing or meeting shall be conducted not less than fourteen nor more than thirty days from the date of the medical staff administrative committee meeting wherein the notice of hearing was received. However, an initial hearing or meeting for a medical staff member who is under summary suspension, which is then in effect, shall be held as soon as arrangements may be reasonably made.
- (2) The medical staff member shall be given at least ten days prior notice of the scheduled hearing, provided that this notice may be waived in writing by the medical staff member. Notice shall be by certified return receipt mail to the staff member at the staff member's last known address as reflected by university records. The notice of hearing shall state in concise language the acts or omissions with which the medical staff member is charged; a list of representative charts or documents being used; names of potential witnesses to be called; and any other reasons or evidence-that may be considered by the medical staff administrative committee during the hearing.
- (D) Conduct of hearing.
- (1) ~~A majority of the members of the medical staff administrative committee shall be present to convene the hearing and a majority which has heard all the evidence~~ The hearing committee shall select a chairperson from the committee membership to preside over the hearing. The hearing committee shall have benefit of Ohio state university legal counsel. The hearing committee may grant continuances, recesses, and the chairperson may excuse a member of the hearing committee from attendance temporarily for good cause, provided that there shall be at no time less than two members of the hearing committee present unless the affected staff member waives this requirement.
- All members of the hearing committee must be present to deliberate and to vote. No member may vote by proxy. The person who has taken the action from which the affected staff member has requested the hearing shall not participate in the deliberation or voting of the hearing committee. The hearing shall be a de novo hearing, although evidence of the prior recommendations and decisions of the director and the various committees may be presented. Neither the director nor any staff member who has been designated to carry out the duties and responsibilities of the director under these procedures shall participate in any way in the proceedings or deliberations of the committee except as an observer, a witness, or to explain prior recommendations and decisions. The committee shall select a chairperson from the committee membership for the purpose of conducting the hearing. The person who brings the charge shall not participate in the deliberation or voting of the committee.
- (2) An accurate record of the hearing ~~must~~ shall be kept. The record shall be done by the use of a professional stenographer. This record ~~will~~ shall be available to the affected member of the medical staff upon request at the affected member's expense.
- (3) The personal presence of the medical staff member for whom the hearing has been scheduled shall be required. A medical staff member who fails without good cause to appear and proceed at such hearing shall be deemed to have waived the right to appear

**AMENDMENTS TO THE BYLAWS OF THE MEDICAL STAFF OF THE ARTHUR G. JAMES
CANCER HOSPITAL AND RICHARD J. SOLOVE RESEARCH INSTITUTE (contd)**

Amended Bylaws of the Medical Staff of The James (contd)

and to have a hearing before the medical staff administrative committee in the same manner as provided in paragraph (B) of this rule, and to have accepted the adverse recommendation or decision involved and the same shall therein become and remain in effect as provided in paragraph (B) of this rule. ~~The medical staff administrative hearing committee may, at its own discretion, proceed with the hearing without the medical staff member and impose a sanction.~~

(4) through (6) unchanged.

(7) ~~The medical staff administrative committee may, without special notice, recess the hearing and reconvene the same for the convenience of the participants or for the purpose of obtaining new or additional evidence or consultation. Upon conclusion of the presentation of oral and written evidence, the hearing shall be closed. The committee may thereupon, at a time convenient to itself, conduct its deliberations outside the presence of the medical staff member for whom the hearing was convened. The hearing committee shall request the person who has taken the action from which the affected medical staff member has requested the hearing to present evidence to the hearing committee in support of the adverse recommendation. The hearing committee may proceed to hear evidence and testimony from either party in whatever order the hearing committee deems appropriate. The hearing committee may call its own witnesses, may recall any parties witnesses, and may question witnesses as it deems appropriate. All parties shall be responsible to secure the attendance of their own witnesses. All witnesses and evidence received by the hearing committee shall be open to challenge and cross examination by the parties. Witnesses shall not be placed under oath. At the close of the evidence the hearing committee may request each party to make summary statements, either oral or written.~~

(8) The hearing committee may, without special notice, recess the hearing and reconvene the same for the convenience of the participants or for the purpose of obtaining new or additional evidence or consultation. The hearing committee shall make its best effort to expeditiously determine the issues presented. The hearing committee may limit its proceedings when sufficient material has been received. The parties may be required to provide evidence in oral or written form. Upon conclusion of the presentation of evidence the hearing shall be closed. The hearing committee may there upon, at a time convenient to itself, conduct its deliberations outside the presence of the medical staff member for whom the hearing was convened.

(9) Within sixty days after its appointment, unless otherwise extended by the medical staff administrative committee, the hearing committee shall forward its written report and recommendation together with the transcript of the hearing and all other documentation presented by the parties to the medical staff administrative committee. The affected member shall be notified of the recommendation of the hearing committee including a statement of the basis for the recommendation. The medical staff administrative committee shall accept, reject, or modify the recommendation of the hearing committee. The medical staff administrative committee may conduct further hearings as it deems necessary or may remand the matter back to the hearing committee for further action as directed. The medical staff administrative committee may impose a greater or lesser sanction than that recommended by the hearing committee.

~~(8)~~

(10) Within fourteen days after the conclusion of the taking of all evidence and of all hearings, the medical staff administrative committee shall make a written report of its findings and its recommendation and shall forward the same together with the hearings record and all

**AMENDMENTS TO THE BYLAWS OF THE MEDICAL STAFF OF THE ARTHUR G. JAMES
CANCER HOSPITAL AND RICHARD J. SOLOVE RESEARCH INSTITUTE (contd)**

Amended Bylaws of the Medical Staff of The James (contd)

other documentation to the chairperson of the hospital CHRI board. ~~The decision may recommend confirmation, modification, or rejection of the prior adverse decision and may impose more severe sanctions than were provided in the decision from which this request for hearing was made. The affected member of the medical staff shall be notified of the decision of the executive committee by the director.~~ Notice of that decision shall be sent certified return receipt mail to the affected medical staff member at the member's last known address as determined by university records by the director.

~~(9)~~

(11) The decision and record of the medical staff administrative committee shall be transmitted to the professional affairs committee of the hospital CHRI board, which shall, subject to the affected member's right to appeal and implementation of paragraph (E) of this rule, consider the matter at its next scheduled meeting, or at a special meeting to be held no less than thirty days following receipt of the transmittal. The professional affairs committee may accept, reject, or modify the decision of the medical staff administrative committee.

~~(10)~~

(12) The recommendation of the professional affairs committee shall be promptly considered by the hospital CHRI board at its next scheduled meeting. The hospital CHRI board may accept, reject, or modify the recommendation of the professional affairs committee.

~~(11)~~

(13) A copy of the hospital CHRI board decision shall be sent by certified return receipt mail to the affected medical staff member at the member's last known address as determined by university records.

(E) Appeal process.

(1) Within fourteen days after receipt of a notice by an affected medical staff member of the action of the medical staff administrative committee the staff member may, by written notice to the chairperson of the hospital CHRI board, request an appeal. Such appeal shall only be held on the record before the medical staff administrative committee.

(2) Unchanged.

(3) The appeal shall be conducted by the professional affairs committee of the hospital CHRI board.

(4) Unchanged.

(5) New or additional matters not raised during the ~~grievance committee~~ hearing procedure or in the medical staff administrative committee hearings shall only be introduced on appeal at the sole discretion of the professional affairs committee.

(6) Within fourteen days following submission of the written statement by the affected medical staff member, the professional affairs committee shall recommend to the hospital CHRI board that the adverse decision be affirmed, modified or rejected, or to refer the matter back to the medical staff administrative committee for further review and recommendation. Such referral to the medical staff administrative committee may include a request for further investigation.

**AMENDMENTS TO THE BYLAWS OF THE MEDICAL STAFF OF THE ARTHUR G. JAMES
CANCER HOSPITAL AND RICHARD J. SOLOVE RESEARCH INSTITUTE (contd)**

Amended Bylaws of the Medical Staff of The James (contd)

- (7) Any final decision by the ~~hospital~~ CHRI board shall be communicated by the director by certified return receipt mail to the affected medical staff member at the member's last known address as determined by university records. The director shall also notify in writing the senior vice president for health sciences, the dean of the college of medicine and public health, the chief medical officer of OSU health system, the vice president for health services, the director of medical affairs, chief of staff, the CHRI section chief, academic department chair ~~chairperson~~ and the person(s) who initiated the request for peer review. The director shall take immediate steps to implement the final decision. (B/T 9/1/93, B/T 4/5/2002, B/T 9/6/2002)

3335-111-07 Divisions of the medical staff.

The medical staff of the CHRI shall be divided into honorary, attending, associate attending, clinical, community oncologist attending, community associate, and limited designations. All medical staff members with admitting privileges may admit patients in accordance with state law and criteria for standards of care established by the medical staff.

(A) Honorary staff.

The honorary staff will be composed of those individuals recognized for outstanding reputation, notable scientific and professional contributions, and high professional stature in an oncologic field of interest. They shall enjoy all privileges and responsibilities of attending staff appointments except patient care privileges and the right to vote and hold elected office in the medical staff organization. The honorary staff designation is awarded by the CHRI ~~board of trustees of the Ohio state university~~ on the recommendation of the director of the CHRI, senior vice president for health sciences ~~and dean of the college of medicine and public health~~, chief of a CHRI section, or the credentials committee after approval by the medical staff administrative committee. This is a life-time appointment.

(B) Attending staff.

(1) and (2) unchanged.

(3) Responsibilities:

An attending staff member shall:

(a) Unchanged.

(b) Retain responsibility within their area of professional competence for the continuous care and supervision of each patient in the CHRI for whom he or she is providing care, or arrange a suitable alternative for such care and supervision, including whenever the patient requires care that is beyond the scope of the attending staff member's capabilities or delineated clinical privileges. This provision includes the supervision of interns, residents and fellows assigned to his/her service. The training of limited staff shall include oversight by the attending physician of clinical care provided to the patient, didactic instruction and observation of diagnostic and therapeutic procedures in accordance with the essentials of the ACGME accredited program in which the limited staff member is enrolled. The attending physician shall participate in the evaluation of limited staff's clinical performance as determined by the appropriate limited staff member's residency program director.

(c) through (e) unchanged.

**AMENDMENTS TO THE BYLAWS OF THE MEDICAL STAFF OF THE ARTHUR G. JAMES
CANCER HOSPITAL AND RICHARD J. SOLOVE RESEARCH INSTITUTE (contd)**

Amended Bylaws of the Medical Staff of The James (contd)

(C) Unchanged.

(D) Clinical staff.

(1) Qualifications:

The clinical attending staff shall consist of those clinical faculty members of the colleges of medicine and public health and dentistry who have training, expertise, and experience in oncology, as determined by the director in consultation with the chief of the appropriate CHRI section.

(2) and (3) unchanged.

(E) Community oncologist attending staff.

(1) Qualifications:

The community oncologist attending (COA) staff shall consist of medical staff members who do not have faculty appointments in any of the academic units of the Ohio state university, are licensed in the state of Ohio with a proven career commitment to oncology as demonstrated by:

Training.

Current American board of medical specialties certification, if applicable.

Practice profile.

Membership - professional oncology societies.

Publications.

Grant funding.

Other funding and experience (as approved by the CHRI director);

Individual COA staff utilization expectations shall be determined by the CHRI director with the advice of the CHRI director of medical affairs and shall be intended to provide optimal access for patients to the CHRI that does not interfere with the service, research, or educational activities and priorities of the university faculty who constitute the CHRI attending, associate attending, or clinical attending staff. The CHRI director and the staff member applying for COA privileges will mutually identify the applicant's CHRI clinical and/or non-clinical involvement, including the categories of diagnosis, extent of anticipated patient activity, and the service areas to be utilized each year. A statement of this participation will be made a part of the application for appointment.

All applications for appointment and reappointment as a member of the COA staff shall be made to the CHRI director for initial evaluation. The CHRI director may, when appropriate, refer each application for completion of the appointment procedure in accordance with paragraphs (E) or (F) of rule 3335-111-04 of the Administrative Code. However, the approval of a an academic department chairperson and CHRI chief of section shall not be required for the appointment or reappointment relative to any application for COA staff privileges. The staff member's ability to cooperate and support the goals identified by the CHRI director will be considered in the decision for appointment and reappointment. Adequate levels of clinical activity may be required to permit proper evaluation under CHRI quality assurance and utilization guidelines.

(2) Unchanged.

**AMENDMENTS TO THE BYLAWS OF THE MEDICAL STAFF OF THE ARTHUR G. JAMES
CANCER HOSPITAL AND RICHARD J. SOLOVE RESEARCH INSTITUTE (contd)**

Amended Bylaws of the Medical Staff of The James (contd)

(3) Responsibilities:

A ~~community~~ Community oncology attending staff member shall:

(a) through (g) unchanged.

(F) Community associate staff.

(1) Qualifications:

The community associate medical staff shall consist of those applicants who do not have faculty appointments in any of the academic units of the Ohio state university and who are licensed in the state of Ohio. All applications for appointment and reappointment to the community associate staff shall be made to the director for initial evaluation. The director shall consult with the chairperson of the appropriate ~~clinical~~ academic department and when appropriate may refer each application for completion of the appointment procedure in accordance with pertinent requirements of paragraph (E) or (F) of rule 3335-111-04 of the Administrative Code. The approval of the academic department chairperson or CHRI chief of section shall not be required.

(2) and (3) unchanged.

(G) Limited ~~medical~~ staff.

Limited staff are not considered members of the medical staff, do not have delineated clinical privileges, and do not have the right to vote in general medical staff elections. Except where expressly stated, limited staff are bound by the terms of these bylaws, rules and regulations of the medical staff and the limited staff agreement.

(1) Qualifications:

The limited staff shall consist of allopathic and osteopathic physicians, and dental surgeons who are ~~appointed~~ accepted in good standing ~~to programs~~ by a program director into a postdoctoral graduate medical education program approved by the institutional post graduate medical education committee.

(2) Responsibilities:

The limited staff shall:

(a) Unchanged.

(b) Not admit patients but participate under supervision, in the care of all patients to whom they are assigned. They shall follow all rules and regulations of the service to which they are assigned, as well as the general rules of the CHRI pertaining to limited staff, including, but not limited to this requirement. Consultation shall be obtained with the attending, associate attending, clinical member of the medical staff responsible for the care of that patient before undertaking a procedure or treatment that carries a significant material risk to the patient unless this consultation would cause a delay that would jeopardize the life or health of the patient.

(c) and (d) unchanged.

**AMENDMENTS TO THE BYLAWS OF THE MEDICAL STAFF OF THE ARTHUR G. JAMES
CANCER HOSPITAL AND RICHARD J. SOLOVE RESEARCH INSTITUTE (contd)**

Amended Bylaws of the Medical Staff of The James (contd)

(H) Associates to the medical staff.

(1) through (3) unchanged.

(4) Due process:

Licensed allied health professionals are subject to corrective action for violation of these rules, their certificate of authority, standard care agreement, utilization plan or the provisions of their licensure, including professional ethics. Corrective action may be requested by any member of the medical staff, the chairperson of a an academic department, the chief of the CHRI section or the director of medical affairs. All requests shall be in writing and be submitted to the director of medical affairs.

The director of medical affairs shall appoint a three-person committee to review the situation and recommend appropriate corrective action, including termination or suspension of clinical privileges. The committee shall consist of at least one licensed allied health professional licensed in the same field as the individual being reviewed, if available, and one medical staff member. The committee shall make a written recommendation to the director of medical affairs, who may accept, reject or modify the recommendation. The decision of the director of medical affairs shall be final.

(I) Clinical privileges.

(1) Delineation of clinical privileges:

(a) Unchanged.

(b) Each clinical department and CHRI section will develop clinical criteria and standards for the evaluation of privileges with emphasis on invasive or therapeutic procedures or treatment which represent significant risk to the patient or for which specific professional training or experience is required. The evaluation of every initial application for clinical privileges shall be based upon the applicant's education, training, experience, demonstrated competence and adherence to quality assurance standards, references and other relevant information, including an appraisal by the chief of the CHRI section in which such privileges are sought. The applicant shall have the burden of establishing qualifications and competence in the clinical privileges requested and the recommendation for increase or reduction of same shall be the responsibility of the credentials committee.

(c) A leave of absence from clinical privileges for voluntary or involuntary medical reasons, for greater than thirty days, must be requested by each medical staff member in writing and be referred to the director of medical affairs office, whenever the medical reason for the leave relates to the medical staff member's possession of the necessary health status to exercise the clinical privileges granted to him or her, or to fulfill the essential functions of his or her appointment to the medical staff, with or without reasonable accommodation. The director of medical affairs may notify the committee for physician health. This section does not mean that members of the medical staff may not have a duty to self report absences of less than thirty days to the chief of the James CHRI section when the absence is based upon the ability to exercise and fulfill essential functions of his or her clinical privileges or medical staff appointment.

**AMENDMENTS TO THE BYLAWS OF THE MEDICAL STAFF OF THE ARTHUR G. JAMES
CANCER HOSPITAL AND RICHARD J. SOLOVE RESEARCH INSTITUTE (contd)**

Amended Bylaws of the Medical Staff of The James (contd)

After a leave for medical reasons of greater than thirty days, a written request for reinstatement must be reviewed and approved by the director of medical affairs in consultation with the committee for physician health, if necessary. Upon return from a leave of absence for medical reasons, the medical staff member must demonstrate his/her ability to exercise his/her clinical privileges upon return to clinical activity. The credentials committee, the director of medical affairs, the CHRI section chief or the medical staff administrative committee shall have the authority to require any documentation, including advice and consultation from the committee on physician health that might have a bearing on the medical staff member's ability to carry out the clinical and educational responsibilities for which the medical staff member is seeking privileges. The committee for physician health will have the responsibility to consider and recommend reasonable accommodations that will enable the medical staff member to practice in a safe and acceptable manner. Any accommodation must be arranged and implemented prior to the exercise of clinical privileges.

(2) Temporary and special privileges:

(a) Temporary privileges -- with the written request and approval of the chairperson of the academic department in which the privileges will be exercised and the chief of the CHRI section, the director of medical affairs may act on behalf of the ~~hospital~~ director and the CHRI board and grant temporary privileges when an application for full appointment is pending and there are specific patient care needs that mandate an immediate authorization to practice. An appropriately licensed professional may be granted temporary privileges for an initial period of thirty days, with subsequent renewals approved by the director of medical affairs not to exceed the pendency of the application. Such privileges shall be exercised in accordance with the conditions specified in rule 3335-111-04 of the Administrative Code.

(b) Special privileges -- upon receipt of a written request for specific temporary privileges and the approval of the chairperson of the academic department, the chief of the CHRI section and the director of medical affairs, an appropriately licensed practitioner of documented competence, who is not an applicant for medical staff membership, may be granted special privileges for the care of one or more specific patients. Such privileges shall be exercised in accordance with the conditions specified in rule 3335-111-04 of the Administrative Code.

(c) A physician may employ or utilize the services of a non-licensed professional assistant in the administration of patient care if this assistant has a defined job description, has received credentials review and approval by the appropriate ~~hospital~~ CHRI reviewing body, and is operating within existing ~~hospital~~ CHRI standards, policies, and procedures. The physician will be responsible for all patient care activities performed on his or her behalf.

(d) Unchanged.

(3) Emergency privileges.

Emergency privileges may be granted by the director of medical affairs or designee to fully licensed, qualified individuals who, at the time of the emergency, are not members of the medical staff in order to provide voluntary services during a local, state or national emergency in accordance with CHRI and medical staff policies.

**AMENDMENTS TO THE BYLAWS OF THE MEDICAL STAFF OF THE ARTHUR G. JAMES
CANCER HOSPITAL AND RICHARD J. SOLOVE RESEARCH INSTITUTE (contd)**

Amended Bylaws of the Medical Staff of The James (contd)

(4) Telemedicine.

A member of the medical staff who wishes to utilize electronic technologies (telemedicine) to render care must so indicate on the application for clinical privileges form. (B/T 9/1/93, B/T 3/3/95, B/T 4/3/96, B/T 12/6/96, B/T 9/1/99, B/T 12/3/99, B/T 6/2/2000, B/T 4/5/2002)

3335-111-08 Organization of the CHRI.

(A) The director.

(1) Method of appointment:

The director shall be appointed by the board of trustees of the Ohio state university upon recommendation of the president, senior vice president for health sciences, and the vice president for health services following consultation with the CHRI board and in accordance with university bylaws, rules and regulations. The director shall also be the chief executive and operating officer of the CHRI and shall be a member of the attending medical staff of the CHRI.

(2) Responsibilities:

The director shall be responsible ~~to the board of trustees by way of the president of the Ohio state university~~ for the conduct of teaching, research, and CHRI service activities of the facility, including continuing compliance with all appropriate quality assurance standards, ethical codes, or other monitoring or regulatory requirements. The director shall be the chairperson of the medical staff administrative committee and shall be a member of all committees of the CHRI.

(B) The director of medical affairs.

(1) Method of appointment:

The director of medical affairs shall be appointed by the ~~board of trustees of the Ohio state university~~ senior vice president for health sciences upon recommendation by the director. The director of medical affairs shall be the chief medical officer of the CHRI and shall be a member of the attending medical staff of the CHRI.

(2) Responsibilities:

The director of medical affairs shall be responsible to the director, the chief medical officer of the university medical center, and the CHRI board for the quality of patient care provided in the CHRI. The director of medical affairs shall assist the director in the administration of medical affairs including quality assurance and credentialing.

(C) The sections.

Each member of the attending, associate attending, clinical, limited, and honorary staff shall be assigned to a CHRI section by the director upon the recommendation of the appropriate academic department chairperson and the credentials committee.

**AMENDMENTS TO THE BYLAWS OF THE MEDICAL STAFF OF THE ARTHUR G. JAMES
CANCER HOSPITAL AND RICHARD J. SOLOVE RESEARCH INSTITUTE (contd)**

Amended Bylaws of the Medical Staff of The James (contd)

There are four clinical sections: medical oncology, surgical oncology, radiation oncology and pathology. Appointment to a specific section is based on the clinical specialty of the applicant for medical staff membership. Each section is headed by a section chief who has the responsibility to oversee all research and clinical activities conducted by members of the section. Specifically, the section chief shall be responsible for the following: the development and implementation of policies and procedures that guide and support the provision of service; recommendations re: staffing needs and clinical privileges for all members appointed to the section; the orientation and continuing surveillance of the professional performance of all section members; recommendation for space and other resources needed. The section chief is appointed by the director.

(D) Department ~~chairs~~ chairpersons.

Departmental chairpersons are appointed by the dean of the college of medicine and public health and participate in the processing of applications for appointment and reappointment to the medical staff pursuant to these rules, including the development of criteria for granting of clinical privileges, ~~and may also be appointed to serve as delegates at large on the medical staff administrative committee.~~ The chair academic department chairperson participates in the evaluation of the professional growth and appropriate humanistic qualities of members of the limited medical staff and reviews the clinical performance, including the physical and mental health of all medical staff members and other licensed health care professionals.

~~(E) Disease-specific committees. (Services)~~

~~The chiefs of CHRI services are appointed by the director in consultation with departmental chairpersons. The chiefs of CHRI services are responsible for research activities in their services. This includes the generation of new clinical protocols and the accrual of patients to these trials. The CHRI services may be added or deleted upon the recommendation of the director with the concurrence of a majority of the medical staff administrative committee and approval of the board of trustees of the Ohio state university. The addition/deletion of a CHRI service by the director is partially a function of the numbers of faculty, numbers of patients treated, research and educational activities, as well as what is perceived to be in the best interest of the mission of the CHRI. (B/T 9/1/93, B/T 3/3/95, B/T 12/6/96, B/T 12/3/99, B/T 4/5/2002, B/T 9/6/2002)~~

3335-111-09 Elected officers of the medical staff of the CHRI.

(A) and (B) unchanged.

(C) Delegates at-large.

There shall be ~~six~~ two delegates at-large, ~~three~~ one to be elected from the attending or represent the associate and clinical attending staff and ~~three~~ appointed from the ranks of departmental chairs pursuant to these bylaws one to represent all other medical staff categories.

(D) through (G) unchanged.

3335-111-10 Administration of the medical staff of the CHRI.

Medical staff committees.

**AMENDMENTS TO THE BYLAWS OF THE MEDICAL STAFF OF THE ARTHUR G. JAMES
CANCER HOSPITAL AND RICHARD J. SOLOVE RESEARCH INSTITUTE (contd)**

Amended Bylaws of the Medical Staff of The James (contd)

(A) Appointments: Appointments to all medical staff committees except the medical staff administrative committee and the nominating committee will be made jointly by the chief of staff, chief of staff-elect, and the director of medical affairs. Unless otherwise provided by the bylaws, all appointments to medical staff committees are for one year and may be renewed. The chairperson shall control the committee agenda, attendance of staff and guests and conduct the proceedings. A simple majority of appointed voting members shall constitute a quorum. All committee members appointed or elected to serve on a medical staff committee are expected to participate fully in the activities of those committees.

(B) Medical staff administrative committee:

(1) Composition:

(a) Chief of staff, chief of staff-elect; section chiefs of medical oncology, radiation oncology, surgical oncology and pathology; CHRI chair of clinical quality management policy group; ~~chiefs of CHRI services~~; CHRI director, CHRI deputy director, CHRI director of administration, CHRI director of medical affairs, ~~CHRI immediate past chief of staff~~, CHRI associate director for professional education; ~~six~~ two at-large delegates, CHRI administrator for nursing; CCC director for clinical research, and CCC director for cancer control, ~~senior vice president for health sciences and dean of the college of medicine and public health and university hospitals medical director.~~

~~(b) All of the above will have voting privileges, except the CCC directors, the administrator for nursing, the senior vice president for health sciences and dean of the college of medicine and public health, university hospitals medical director, and the director of administration who will be ex-officio non-voting members.~~

~~(c)~~

(b) Any member of the committee who anticipates absence from a meeting of the committee may appoint a temporary substitute as a representative at the meeting. The temporary substitute will have all the rights of the absent member. The director may invite any member of staff as the director's representative at a meeting or to attend any meeting with the director.

(c) All members of the committee shall attend, either in person or by proxy, a minimum of two-thirds of all committee meetings.

(2) Duties:

(a) through (d) unchanged.

(e) To fulfill the medical staff's accountability to the CHRI board of trustees of the Ohio state university for medical care rendered to patients in the CHRI.

(f) through (m) unchanged.

(3) Unchanged.

(4) Voting:

At a properly constituted meeting, voting shall be by a simple majority of members present except in the case of termination or non-reappointment of medical staff

**AMENDMENTS TO THE BYLAWS OF THE MEDICAL STAFF OF THE ARTHUR G. JAMES
CANCER HOSPITAL AND RICHARD J. SOLOVE RESEARCH INSTITUTE (contd)**

Amended Bylaws of the Medical Staff of The James (contd)

membership or permanent suspension of clinical privileges, wherein two-thirds of members present shall be required.

(C) and (D) unchanged.

(E) Committee for physician health.

(1) Unchanged.

(2) Duties:

(a) and (b) unchanged.

(c) To provide appropriate internal and external counsel and referral for diagnosis and treatment ~~to enable physicians to provide appropriate standards of care.~~

(d) To consult regularly with the chief of staff and director of medical affairs of the ~~hospital~~ CHRI in monitoring the affected physician and the safety of patients until rehabilitation or any disciplinary process is complete.

(e) through (g) unchanged.

(F) and (G) unchanged.

3335-111-11 Amendments.

These medical staff bylaws may be amended after notice is given at one meeting of the medical staff administrative committee. Such notice shall be laid on the table until the next meeting and shall require two-thirds vote of the members of the medical staff administrative committee present for approval and submission to the medical staff for ratification. Ratification of an amendment shall be by a plurality of those medical staff members voting through written ballot. When an amendment is approved by the medical staff administrative committee and ratified by the medical staff it shall be forwarded to the ~~hospital's~~ CHRI board and the Ohio state university board of trustees. Each of the foregoing reviewers shall accept or reject the requested amendment. The amendment shall become effective when accepted by the board of trustees of the Ohio state university in the form ratified by the medical staff. Neither the medical staff, ~~hospital's~~ CHRI board nor the board of trustees may unilaterally amend the medical staff bylaws. (B/T 9/1/93, B/T 3/3/95, B/T 12/3/99, B/T 9/6/2002)

3335-111-13 Meetings and dues.

(A) Meetings.

The medical staff of the CHRI shall conduct scheduled meetings semi-annually. Notice of the meetings will be sent to all medical staff at least two weeks prior to the meeting. Attendance is encouraged, but shall not be a requirement of continuing staff privileges. ~~Exceptions requested in writing may be sent to the chief of staff who recommends action to the medical staff administrative committee.~~ A special meeting may be called at the option of the medical staff administrative committee.

(B) Unchanged.

Summary
Revision of the Classified Civil Service Rules
And Civil Service Modernization Project

The Ohio State University and other Ohio universities in the Inter-University Council (IUC) are working together to modernize university civil service on the statewide level. In November 1999, an IUC Presidential Task Force issued a report entitled "Recommendations for Improving the Efficiency in State Operations Affecting Public Universities;" one of the recommendations was to reinvent the Classified Civil Service (CCS) system.

The reasons behind this drive to modernize the CCS system are numerous. The current CCS process is slow, cumbersome, and expensive. In the changing job marketplace, universities must operate with speed and agility to compete for the most talented and diverse staff, and have highly positive employee/labor relations. The nature of staff job duties has shifted dramatically over the past decades, requiring new conceptualization of employment testing and selection. State funding for higher education has remained relatively flat over the past decade, requiring greater efficiencies to pursue the University's mission.

The CCS Modernization Project does not intend to dismantle employee property rights. Since the beginning of civil service, many federal and state laws addressing employee protections have been passed. Further, many employees are in collective bargaining units, in which employers and unions are able to bargain employment structures and processes.

The employment world in which universities compete, and the expectations of customers and stakeholders, have shifted radically in recent years. Other states have successfully modernized CCS statutes with similar efforts in process for the federal government. Ohio municipalities and public two-year institutions have not been subject to ORC Chapter 124 and have operated with a successful balance of management and employee rights.

The first step to modernizing the CCS within the University is the revision of the current CCS Rules to remove references to Ohio Revised Code Chapter 124. The current CCS Rules shall remain in place at this time, but will be duplicated into existing Human Resources policies. The IUC is working with Representative Buehrer on legislation that would provide greater flexibility to universities and may potentially remove universities from Chapter 124. The IUC is in the process of outlining Model Rules for universities to follow to allow for necessary changes while protecting employee property rights.

At a future date, when the legislation is passed, the Office of Human Resources has created a structure for University CCS governance and drafted of an over-arching rule that provides the Board of Trustees the power to design, implement and administer all aspects of Human Resource functions. Since the CCS rules will be part of University policy by that time, the formal CCS rules will be repealed. OHR will enter a communication and input phase with the University community to envision the ideal human resources environment and incorporate best practices. OHR then will design and implement appropriate processes with supporting systems and policies.

Amended Classified Civil Service Rules

3335-51-01 Position audits and reclassifications.

(A) and (B) unchanged.

(C) When an audit or review is conducted, the following sources for that investigation include, but are not limited to, any employee, an employee's authorized representative, or college/department officer. When the office of human resources finds that inequities or improper classifications of positions exist, appropriate remedial steps may be taken to provide a more equitable, just and proper classification. The affected employee(s) shall be given a written notice of the decision of the audit or review and:

(1) Unchanged.

(2) May refuse the reclassified position, in which case the employee shall retain certification in that classification, and the office of human resources shall assign such employee to a position ~~which~~ that has duties commensurate with the employee's classification. If the former position is no longer used by the university, such position shall be abolished in accordance with Chapter 3335-81 of the Administrative Code.

(D) Unchanged.

(E) Whenever a position reclassification determination is made, ~~the position classification shall change in accordance with division (D) of section 124.14 of the Revised Code~~ the office of human resources shall provide written notice to the employee. The effective date of such change shall be four weeks after receipt of the request in the office of human resources, or the date of conclusive determination, whichever is earlier. An employee may appeal the decision to the state personnel board of review within thirty days of receipt of the decision.

3335-51-02 Notification of employees.

(A) Whenever the classification title of a position changes, other than by process of promotion or demotion, or whenever the university establishes or deletes classifications and such actions result in the reclassification of incumbent classified employees, notification shall be made in writing to any individual affected by the change ~~in accordance with division (D) of section 124.14 of the Revised Code.~~

(B) Unchanged.

3335-55-01 Classification of positions.

All positions in the classified service at the Ohio state university are placed in classifications in ~~accordance with division (F) of section 124.14 of the Revised Code and section 124.20 of the Revised~~ Chapter 3335-55 of the Administrative Code, except those exempted by law.

3335-55-03 Classification plan.

(A) through (D) unchanged.

(E) The following are the classifications to which the university shall assign all positions within the classified service which have not yet been reclassified under the broadbanded classification plan in rule 3335-55-08 of the Administrative Code:

Amended Classified Civil Service Rules (contd)

Position classifications at
the Ohio state university

Pay range	Class	Title description
	10000	Account clerk series
24	10001	Account clerk 1
26	10002	Account clerk 2
27	10003	Account clerk 3
29	10004	Account clerk supervisor
	11000	Accounting series
27	11001	Accountant 1
29	11002	Accountant 2
31	11003	Accountant 3
33	11004	Accounting manager 1
	11110	Agricultural technician series
03	11111	Agricultural aide 1
04	11112	Agricultural aide 2
25	11113	Agricultural technician 1
26	11114	Agricultural technician 2
	12000	Air quality technician series
05	12001	Assistant air quality technician
07	12002	Air quality technician 1
08	12003	Air quality technician 2
	12100	Aircraft maintenance and operations series
06	12101	Aircraft attendant
09	12102	Aircraft mechanic 1
10	12103	Aircraft mechanic 2
	12110	Architectural series
29	12112	Architect associate
	12150	Animal aide/caretaker series
23	12151	Laboratory animal aide
23	12152	Animal caretaker
25	12153	Animal caretaker supervisor
26	12154	Animal caretaker coordinator
	12160	Animal health technician series
27	12161	Animal health technician
<u>27</u>	<u>12162</u>	<u>Laboratory animal health technician</u>
28	12162 <u>12163</u>	Senior animal health technician
	12200	Audio/visual technician series
24	12201	Audio/visual technician
26	12202	Audio/visual repair worker
27	12204	Audio/visual services supervisor 1
28	12205	Audio/visual services supervisor 2

Amended Classified Civil Service Rules (contd)

Position classifications at
the Ohio state university (contd)

	12210	Automotive trades series
05	12211	Assistant automotive mechanic
07	12212	Automotive mechanic 1
08	12213	Automotive mechanic 2
29	12214	Automotive mechanic 3
	13000	Boiler operations series
04	13001	Boiler maintenance worker
06	13003	Boiler operator 2
06	13004	Boiler repair worker
08	13005	Boiler engineer
	13110	Budget/management series
30	13111	Budget/management analyst 1
	13220	Building maintenance series
04	13221	Maintenance repair worker 1
05	13222	Maintenance repair worker 2
06	13223	Maintenance inspector
06	13224	Traffic & parking maintenance worker
07	13225	Maintenance repair worker 3
08	13226	Building systems inspector
27	13227	Building maintenance supervisor
29	13228	Building maintenance superintendent 1
31	13229	Building maintenance superintendent 2
	13250	Building operations technician series
08	13251	Building operations technician 1
11	13252	Building operations technician 2
	13300	Business management series
28	13301	Business services officer 1
29	13302	Business services officer 2
	13310	Carpentry series
05	13311	Assistant carpenter
07	13312	Carpenter 1
08	13313	Carpenter 2
29	13314	Carpentry supervisor
	13330	Chemist series
28	13331	Chemist 1
29	13332	Chemist 2
31	13334	Chemical laboratory supervisor 1
	13400	Childcare series
22	13401	Early childhood teaching assistant 1
22	13402	Early intervention aide
23	13403	Early childhood teaching assistant 2

Amended Classified Civil Service Rules (contd)

Position classifications at
the Ohio state university (contd)

	13500	Clerk residence and dining series
02	13501	Clerk 1 R & D
03	13502	Clerk 2 R & D
	14010	Collections series
27	14011	Financial collection specialist
	14110	Computer operator series
27	14111	Computer operator 1
27	14112	Computer operations & production technician 1
28	14113	Computer operator 2
28	14114	Computer operations & production technician 2
29	14115	Computer operator 3
29	14116	Computer operations & production technician 3
29	14117	Computer operation supervisor 1
30	14118	Computer operator 4
30	14119	Computer operations & production supervisor
30	14120	Computer operation supervisor 2
	14150	Construction technician series
08	14151	Construction technician 1
11	14152	Construction technician 2
12	14153	Construction technician 3
	14200	Cultural support series
24	14201	Library assistant
25	14202	Library media technical assistant 1
26	14203	Library media technical assistant 2
27	14204	Library associate 1
28	14205	Library associate 2
28	14206	Medical records librarian
	14300	Data processing series
23	14301	Data processor 1
24	14302	Data processor 2
25	14303	Data processor 3
26	14304	Data processing supervisor 1
27	14305	Data processing supervisor 2
29	14306	Data systems coordinator 1
30	14307	Data systems coordinator 2
32	14308	Data systems coordinator 3
	14310	Data technician series
24	14311	Data technician 1
25	14312	Data technician 2
27	14313	Data technician supervisor
27	14314	Data control technician
	14320	Delivery worker series
04	14321	Delivery worker 1
05	14322	Delivery worker 2

Amended Classified Civil Service Rules (contd)

Position classifications at
the Ohio state university (contd)

	14330	Dental technology series
24	14331	Dental assistant 1
26	14332	Dental assistant 2
28	14333	Dental assistant 3
	14340	Dairy worker series
04	14341	Dairy worker 1
06	14342	Dairy worker 2
	14400	Design and drafting series
25	14401	Drafting technician 1
27	14402	Drafting technician 2
29	14404	Design technician 1
31	14405	Design technician 2
	14410	Dietary series
02	14411	Nutrition aide
23	14413	Nutritionist specialist
	14420	Duplicating and printing series
25	14421	Printing machine operator 1
25	14422	Bindery operator 1
26	14423	Printing technician 1
26	14424	Printing machine operator 2
28	14425	Printing technician 2
28	14426	Printing machine operator 3
29	14427	Printing supervisor 1
30	14428	Printing supervisor 2
	14430	Electrician series
05	14431	Assistant electrician
07	14432	Electrician 1
08	14433	Electrician 2
12	<u>14434</u>	<u>High voltage electrician</u>
	14440	Electronic technology series
27	14441	Electronic technician 1
28	14442	Electronic technician 2
29	14443	Electronic technician 3
	15000	Employment services series
3029	15003	Payroll officer-supervisor
<u>30</u>	<u>15004</u>	<u>Payroll officer</u>
	15200	Equipment maintenance series
28	15201	Equipment maintenance supervisor
30	15202	Equipment maintenance superintendent 1
31	15203	Equipment maintenance superintendent 2
	15220	Farm maintenance series
04	15221	Farm laborer 1
06	15222	Farm laborer 2

Amended Classified Civil Service Rules (contd)

Position classifications at
the Ohio state university (contd)

28	15223	Farm manager 1
29	15224	Farm manager 2
	15230	Facilities support services series
28	15231	Facilities support services specialist
	15310	Fiscal management series
29	15311	Budget officer 1
30	15312	Fiscal officer 1
32	15314	Fiscal officer 2
	15320	Food management series
01	15321	Food service worker
01	15322	Food service attendant
04	15323	Catering operations assistant
04	15324	Food service supervisor 1
26	15325	Food service supervisor 2
27	15326	Food service manager 1
28-29	15327	Food service manager 2
30	15328	Food service manager 3
	15330	Food preparation series
02	15331	Food preparation worker
03	15332	Cook 1
05	15334	Cook 2
	15410	Grants coordinator series
27	15412	Student financial aid specialist
27	15413	Student services counselor
	15420	Graphic arts series
27	15421	Graphic artist
28	15422	Layout design artist
	15430	Grounds maintenance series
24	15431	Golf course worker 1
04	15432	Groundskeeper 1
05	15433	Groundskeeper 2
26	15434	Golf course worker 2
06	15435	Groundskeeper 3
08	15436	Groundskeeper supervisor
29	15437	Golf course supervisor
	15440	Housekeeping services series
02	15442	Custodial worker
04	15443	Custodial work supervisor
25	15444	Housekeeping manager 1
27	15445	Housekeeping manager 2
28	15446	Assistant superintendent of buildings
29	15447	Housekeeping manager 3
30	15448	Superintendent of buildings
30	15449	Manager-environmental services

Amended Classified Civil Service Rules (contd)

Position classifications at
the Ohio state university (contd)

	15500	Institutional security series
23	15501	Community service officer
26	15503	Security officer
28	15505	Security supervisor
	15520	Inventory control series
26	15521	Inventory control specialist 1
28	15522	Inventory control specialist 2
	15530	Laboratory animal technology series
24	15531	Laboratory animal technician 1
27	15532	Laboratory animal technician 2
28	15533	Laboratory animal technologist
	15540	Laboratory machinist series
28	15541	Laboratory machinist 1
29	15542	Laboratory machinist 2
	15550	Laboratory technology series
23	15551	Laboratory assistant
24	15552	Laboratory technician 1
25	15553	Laboratory technician 2
27	15554	Laboratory technologist
	16000	Laborer series
02	16001	Laborer
	16110	Locksmith series
05	16111	Assistant locksmith
07	16112	Locksmith 1
08	16113	Locksmith 2
	16200	Maintenance machinist series
05	16201	Assistant maintenance machinist
07	16202	Maintenance machinist 1
08	16203	Maintenance machinist 2
	16210	Machinist series
05	16211	Assistant machinist
07	16212	Machinist 1
08	16213	Machinist 2
29	16214	Machinist supervisor
	16300	Mason series
05	16301	Assistant mason
07	16302	Mason
	16310	Materials controller series
27	16312	Materials controller 2
29	16313	Materials controller 3

Amended Classified Civil Service Rules (contd)

Position classifications at
the Ohio state university (contd)

26	16320 16322	Medical technology series ECG technician
28	16340 16341	Microbiologist series Microbiologist 1
29	16342	Microbiologist 2
31	16344	Microbiology supervisor 1
26	16350 16351	Medical technology computer series ECG system operator
07	16360 16361	Mechanical technician series Mechanical technician 1
08	16362	Mechanical technician 2
11	16363	Mechanical technician 3
03	16400 16401	Miscellaneous clerical series Mail clerk/messenger
04	16402	Mail clerk
28	16403	Mail center supervisor
05	16410 16411	Miscellaneous maintenance series Exterminator
07	16420 16422	Miscellaneous trades series Interior surfaces installer <u>Insulation worker</u>
07 <u>08</u>	16423	Insulation worker <u>Interior surfaces installer</u>
25	16430 16431	Morgue series Morgue attendant
27	16432	Morgue supervisor
04	16440 16441	Mover series Mover 1
08	16443	Moving supervisor
28	16460 16461	Nurse series Licensed practical nurse-CCS
29	16462	Licensed practical nurse-Pharm, CCS
22	16500 16501	Office machine operator Series Office machine operator 1
23	16502	Accounting machine operator 1
24	16503	Office machine operator 2
25	16504	Accounting machine operator 2
25	16505	Office machine operator 3
07	16510 16511	Painter series Painter 1
08	16512	Painter 2

Amended Classified Civil Service Rules (contd)

Position classifications at
the Ohio state university (contd)

	16520	Parking facility series
03	16521	Parking facility attendant
27	16522	Parking facility superintendent
	16530	Personnel series
26	16532	Personnel aide
28	16533	Personnel technician 1
28	16535	Personnel officer 1
30	16537	Personnel technician 2
30	16538	Personnel officer 2
	16560	Photographic series
27	16561	Photographer 1
28	16562	Photographer 2
	16600	Photographic laboratory series
23	16601	Photo laboratory assistant
25	16602	Photo laboratory technician 1
26	16603	Photo laboratory technician 2
28	16604	Photo laboratory supervisor
	16610	Plant operations series
08	16612	Stationary engineer 1
29	16613	Plant maintenance engineer 1
09	16614	Stationary engineer 2
30	16615	Plant maintenance engineer 2
	16630	Plumber series
05	16631	Assistant plumber
07	16632	Plumber 1
08	16633	Plumber 2
	16640	Police series
50	16641	University law enforcement officer
32	16644	University law enforcement officer supervisor
	16660	Project engineer series
31	16661	Project engineer 1
32	16662	Project engineer 2
33	16663	Project engineer 3
	17000	Project inspector series
28	17002	Project inspector 2
29	17003	Project inspector 3
	17100	Public information and inquiry series
28	17103	Publication specialist 1
30	<u>17104</u>	<u>Publication specialist 2</u>
31	17107	Publications editor

Amended Classified Civil Service Rules (contd)

Position classifications at
the Ohio state university (contd)

	17200	Purchasing series
25	17201	Purchasing assistant 1
26	17202	Purchasing assistant 2
28	17204	Purchasing agent 1
30	17205	Purchasing agent 2
31	17206	Purchasing administrator 1
32	17207	Purchasing administrator 2
	17210	Radio dispatcher series
25	17211	Radio dispatcher 1
28	17212	Public safety dispatcher 1
27	17213	Radio dispatcher 2
29	17214	Public safety dispatcher 2
	17310	Sales service series
27	17316	Sales manager 2
28	17317	Sales manager 3
	17320	Sheet metal series
05	17321	Assistant sheet metal worker
07	17322	Sheet metal worker 1
08	17323	Sheet metal worker 2
29	17324	Sheet metal supervisor
	17330	Sign shop series
30	17335	Sign shop superintendent
	17420	Steam fitter series
05	17421	Assistant steam fitter
07	17422	Steam fitter
	17430	Stores series
03	17431	Stores clerk
24	17432	Mechanical stores clerk
04	17433	Chemical stores clerk
05	17434	Storekeeper 1
06	17435	Chemical storekeeper 1
27	17436	Storekeeper 2
28	17437	Storekeeper 3
	17440	Surveyor series
30	17442	Surveyor 2
	17450	Systems technician series
07	17451	Systems technician 1
08	17452	Systems technician 2
12	17453	Systems technician 3
	17510	Therapy and institutional services series
24	17511	Hospital aide
24	17512	Activities aide
04	17513	Patient transporter

Amended Classified Civil Service Rules (contd)

Position classifications at
the Ohio state university (contd)

04	17514	Patient services associate
25	17515	Psychiatric aide
25	17516	Therapy aide
05	17517	Perioperative technician
	17520	Treatment plant operations series
06	17521	Treatment plant aide
07	17522	Treatment plant operator
	17530	Traffic control series
26	17532	Traffic control officer
28	17533	Traffic control officer supervisor
	17560	Vehicle and equipment operator series
04	17561	Vehicle operator 1
05	17562	Equipment operator 1
06	17563	Vehicle operator 2
06	17564 <u>17563</u>	Equipment operator 2
07	17565 <u>17564</u>	Equipment operator 3
<u>08</u>	<u>17565</u>	<u>Vehicle operator 2</u>
	17570	Welder series
07	17572	Welder 1
08	17573	Welder 2
	17590	X-ray technology series
23	17591	X-ray developer
25	17592	Radiology service associate
26	17593	X-ray technician 1
27	17594	X-ray technician 2
	18000	Zone maintenance technician series
03-04	18001	Zone maintenance technician 1
07	18002	Zone maintenance technician 2
11	18003	Zone maintenance technician 3
	20000	Automation technician series
07	20001	Automation technician 1
09	20002	Automation technician 2
10	20003	Automation technician 3
	21000	Dietetic clerk series
03	21001	Dietetic clerk
	22000	Phlebotomist series
24	22001	Assistant phlebotomist
25	22002	Phlebotomist 1
26	22003	Phlebotomist 2
27	22004	Phlebotomist supervisor

Amended Classified Civil Service Rules (contd)

Position classifications at
the Ohio state university (contd)

	22100	Anesthesia series
26	22101	Anesthesia technician 1
27	22102	Anesthesia technician 2
	22200	Sterile supply series
04	22201	Sterile supply technician 1
06	22202	Sterile supply technician 2
	23000	Unit clerical series
25	23001	Unit clerical associate
25	23003	Unit clerical coordinator
26	23004	Unit clerical supervisor
	23100	Hospital admitting series
26	23101	Admitting representative
27	23102	Patient admitting representative

3335-55-06 Changes in the pay ranges or classification plan.

The university may reassign the pay ranges of classifications ~~in accordance with divisions (H) and (I) of section 124.14 of the Revised Code and section 3345.31 of the Revised Code~~ and add, modify, or delete classifications. New classifications created pursuant to this rule shall be assigned to one of the established pay ranges. All new or revised classifications must be filed with the secretary of state.

3335-55-08 Broadbanded classification plan.

(A) through (D) unchanged.

(E) The following are the classifications to which the university shall assign positions within the classified service which have been reclassified under the broadbanded classification plan and are no longer subject to the classification plan in rule 3335-55-03 of the Administrative Code:

Position Classifications at
The Ohio State University

Pay Range	Class	Title Description
A1	00010	Information Assistant Series
A2	00020	Information Associate Series
A2	00030	Marketing Staff Coordinator Series
<u>A2</u>	<u>00035</u>	<u>Medical claim specialist series</u>
A2	00040	Office Administrative Associate Series

Amended Classified Civil Service Rules (contd)

Position Classifications at
The Ohio State University (contd)

Pay Range	Class	Title Description
A1	00050	Office Assistant Series
A2	00060	Office Associate Series
A1	00070	Office Production Assistant Series
A2	00080	Office Staff Coordinator Series
A1	00090	Sales Assistant Series
<u>A2</u>	<u>00095</u>	<u>System specialist series</u>

3335-65-12 Exceptional appointments; suspension of examination requirements.

- (A) If a civil service vacancy requires unique and exceptional qualifications of a scientific, managerial, professional or educational character, so that conducting a competitive examination for the position is impractical, then the office of human resources may suspend the provisions of ~~sections 124.01 to 124.64 of the Revised Code as provided in division (B) of section 124.30 of the Revised~~ Chapters 3335-49 to 3335-89 of the Administrative Code, and appoint an applicant who has the recognized qualifications for the position. Employees appointed under this rule attain certified status after successfully serving the probation period stated in rule 3335-67-02 of the Administrative Code.
- (B) In case of an emergency, an appointment process may bypass ~~sections 124.01 to 124.64 of the Revised~~ Chapters 3335-49 to 3335-89 of the Administrative Code. Emergency appointments shall not exceed a maximum of thirty days, and in no case shall successive appointments occur.

**The Ohio State University Board of Trustees
Investments Committee
September 6, 2002**

TOPIC:

Development Funding for FY 2003

CONTEXT:

Rising expectations and a declining stock market have combined to put a squeeze on the budget of the Office of Development. If no remedial action is taken, Development will fall short by more than \$2 million for maintaining existing services.

There are also unmet needs for one-time funds, including a new computer system.

RECOMMENDATION:

- Increase endowment support from 1.1% to 1.33%. This will provide for a total of \$15.8 million for continuation of existing services and a previously approved increase in support for the Medical Center in FY 2003 (Attachment A).
- Fund one-time needs of \$1.2 million from unexpended balances in the Development Reserve Account, and other sources (Attachment B).
- Ask Development to develop a five-year funding plan for FY 2004 that meets priority needs and includes reallocation of resources from lower need to higher need. The plan should be ready by January 1, 2003 (Attachment C).

REQUESTED OF BOARD OF TRUSTEES:

Approval of recommendations.

**Recommended Funding Level
Continuing Funds
(in millions)**

Continuing Service Needs FY 2003 (Compared to \$15,284,000 for FY 2002)	\$15.4
Additional Amount Needed to Meet FY 2003 Commitment to OSUMC	<u>0.4</u>
Total Need	\$15.8
Recommended Sources for FY 2003:	
Endowment Proceeds @ 1.33% ¹	\$14.9
90-day Hold @ 3% ²	0.5
Unrestricted Allocation	<u>0.4</u>
Total Available	\$15.8

¹ 3-year Endowment average = \$1.12B

² Drop in short-term interest rate from 6% to 3% cost \$450,000.

Recommended Uses of One-time Funds

• IMPACT System (Version 2 and build-buy analysis)	\$980,000
• Electronic Screening for Alumni	125,000
• Fawcett Move	<u>90,000</u>
Total	\$1,195,000

**Issues Over Longer Term
To Be Addressed By Five-Year Plan**

- Five-year sources and uses for both continuing and one-time needs.
- Sources, uses and goals for OSUMC sub-campaign.
- Sources, uses and goals for Arts & Sciences reorganization.
- Sources, uses and expected rate of return for Alma Mater System.
- Alternative sources of support, other than endowment earnings.
- Re-evaluation of priorities and internal reallocations.

Thompson Library Renovation**315-2002-046****PROJECT CAPTAIN:**

Scott Conlon, Facilities Planning & Development - Architecture, 292-0983

REQUESTING AGENCY:

University Libraries

PROJECT LOCATION:

LIBRARY, WILLIAMS OXLEY THOMPSON MEMORIAL

AGE:

1912

GR. SQ. FT.:

299,695

PROJECT DESCRIPTION:

Renovate the Thompson Library, construct an addition to the facility, relandscape a portion of the Oval, and construct a new module to the Library Book Depository

MILESTONES:

	Projected	Revised	Actual
Arch/Eng Approved B/T	9/13/2002		
Construction Mgr Approved B/T	9/13/2002		

FUNDING INFORMATION:

Development - Univ Libraries	\$	20,000,000		
Future Capital Appropriations		79,000,000		
Total	\$	99,000,000		

USES:

Construction	\$	72,741,259		
Construction Manager		4,585,182		
Contingency		7,167,711		
Design		6,348,713		
Equipment		3,527,063		
Moving		1,039,082		
Percent for Art		690,000		
Swing Space		1,120,070		
Technology Equipment		793,342		
Univ Administration		987,578		
Total	\$	99,000,000		

COMMENTS:

Local administration granted by DAS and BoR per their letter dated 6/11/02. Project milestones will be defined once funds have been approved. Conceptual project budget is in 2006 dollars. Development and University Libraries have agreed that \$20M - \$30M is a reasonable expectation of donor participation. As the MoU is developed, the funding amount from development will be refined and the capital appropriation amount will be adjusted accordingly within the \$99M total conceptual project amount.

Thompson Library Renovation

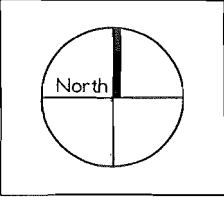
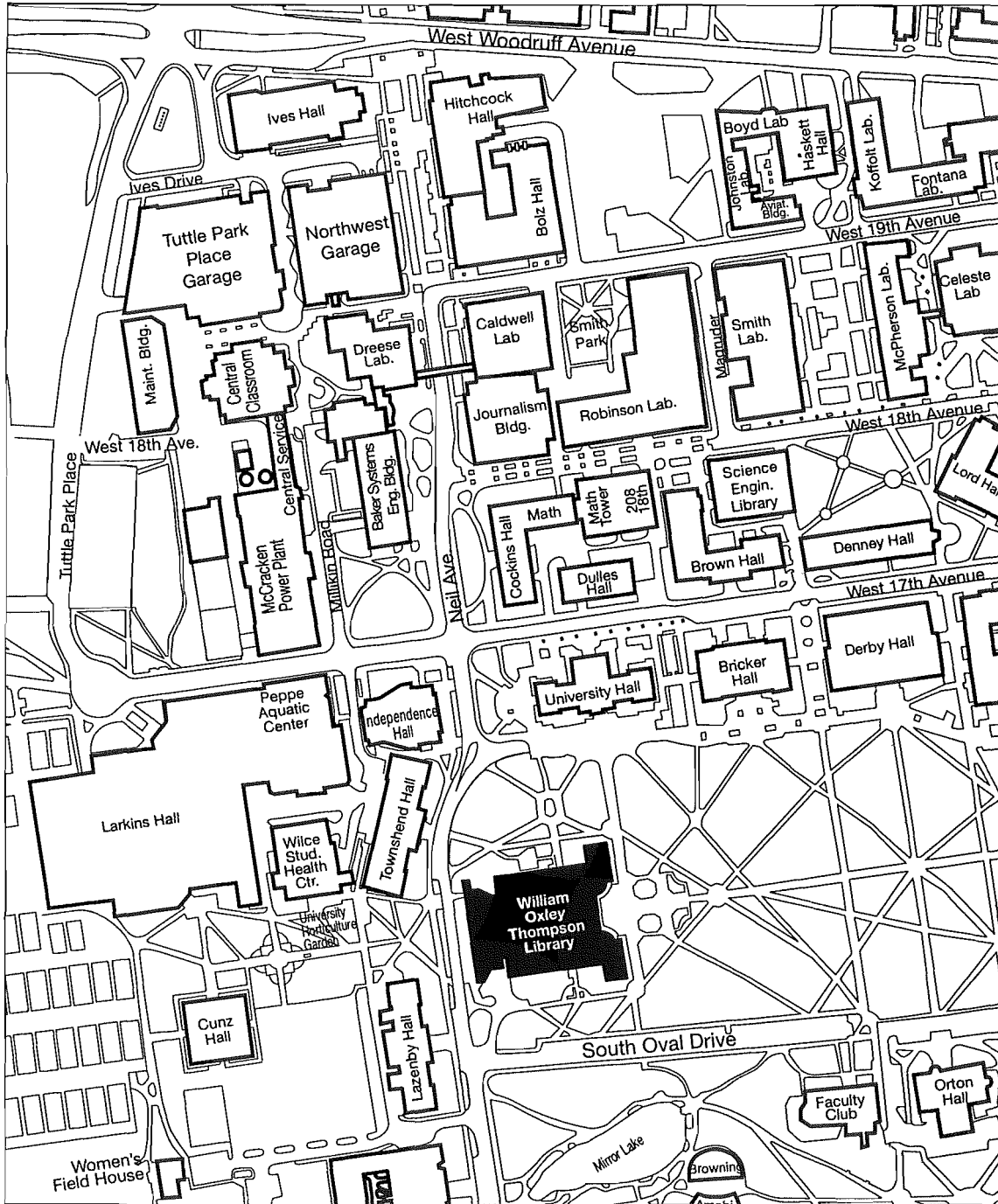

Office of Business and Finance
Office of Facilities Planning and Development

August 17, 2002

Camera Center - Hospital Labs

315-2001-915

PROJECT CAPTAIN:

Lori Seeger, Facilities Planning & Development - Architecture, 688-3757

REQUESTING AGENCY:

University Hospitals

PROJECT LOCATION:

CAMERA CENTER, J LEONARD

AGE:

GR. SQ. FT.:

28,635

PROJECT DESCRIPTION:

Renovate the Bureau of Worker's Compensation property being leased by OSU to use for physician and outpatient services.

MILESTONES:

	Projected	Revised	Actual
Arch/Eng Approved B/T	5/1/1998		5/1/1998
Bidding Approved B/T	9/13/2002		
Schematic Design Approval	4/1/2004		
Design Dev Document Approval	4/1/2004		
Construction Document Approval	4/1/2004		

FUNDING INFORMATION:

Auxiliaries - Univ Hospitals	\$	10,000,000	
Total	\$	10,000,000	

USES:

Construction	\$	8,120,000	
Contingency		975,000	
Design		807,000	
Univ Administration		98,000	
Total	\$	10,000,000	

COMMENTS:

Project will be accomplished in multiple phases. This project replaces the Community Ambulatory Care Center projects (315-1998-907 and 315-1998-909) approved by the Board of Trustees on May 1, 1998.

Camera Center - Hospital Labs

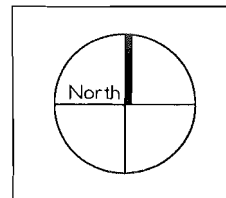
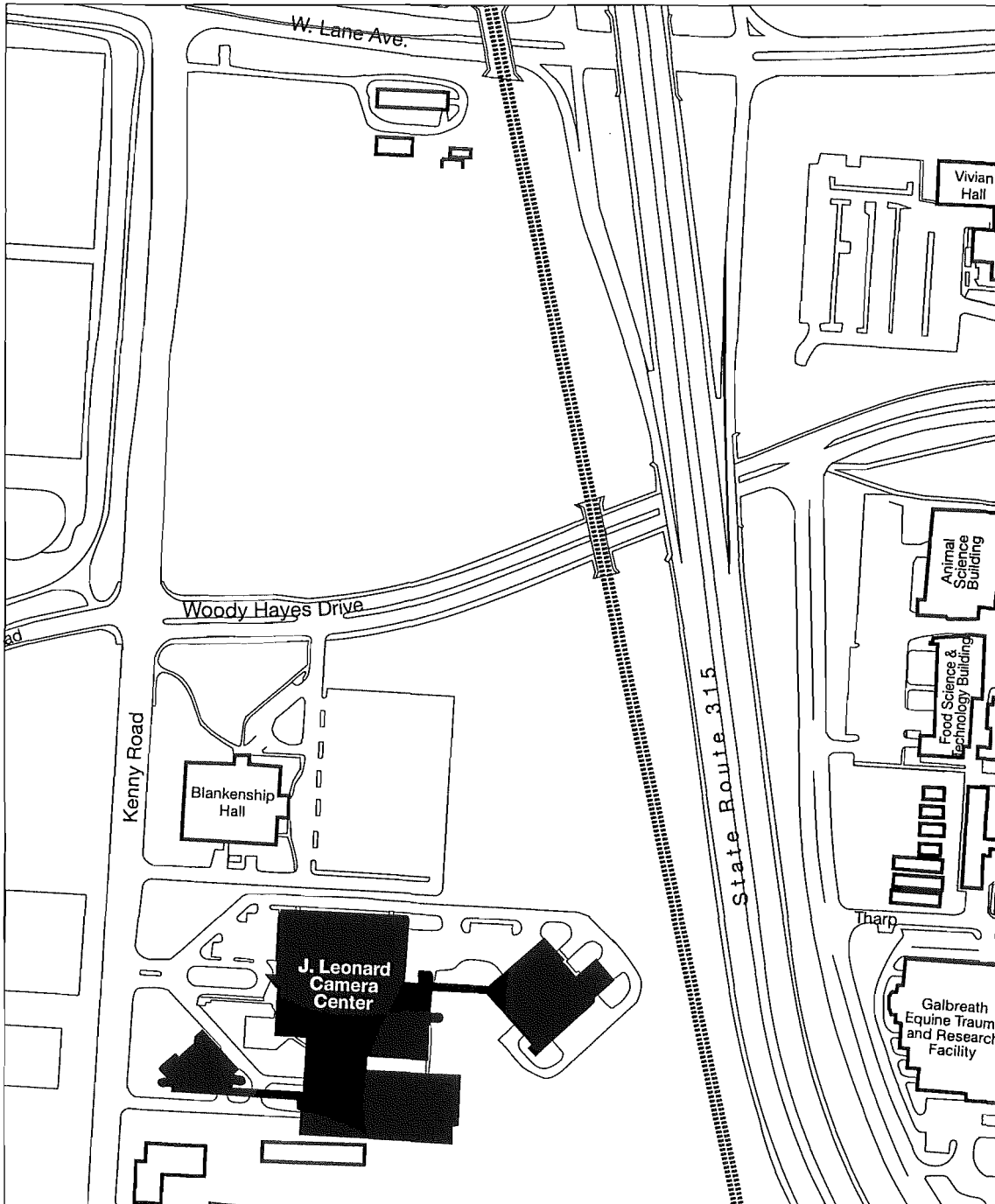

Office of Business and Finance
Office of Facilities Planning and Development

August 17, 2002

Fry Hall Addition**315-2001-922****PROJECT CAPTAIN:**

Sara Herridge, Facilities Planning & Development - Architecture, 292-0381

REQUESTING AGENCY:

College of Optometry

PROJECT LOCATION:

CAMERA CENTER, J LEONARD

AGE:

1951

GR. SQ. FT.:

46,910

PROJECT DESCRIPTION:

Construct a three floor addition to the existing Fry Hall to house additional clinical and office areas for patient based research.

MILESTONES:

	Projected	Revised	Actual
Arch/Eng Approved B/T	9/13/2002		5/1/1998

FUNDING INFORMATION:

BOR Action Fund	\$	1,000,000	
Development - Optometry	\$	1,000,000	
General Funds - Optometry		500,000	
Future Capital Appropriations		3,600,000	
Grant - NIH		2,000,000	
Total	\$	8,100,000	

USES:

Construction	\$	5,801,674	
Contingency		1,007,607	
Design		522,151	
Equipment		516,584	
Moving		29,338	
Swing Space		141,423	
Univ Administration		81,223	
Total	\$	8,100,000	

COMMENTS:

Conceptual project budget is in 2005 dollars. Project schedule will be determined as a part of the Programming Phase.

Fry Hall Addition

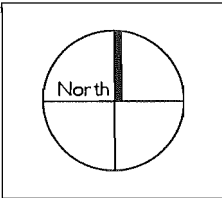
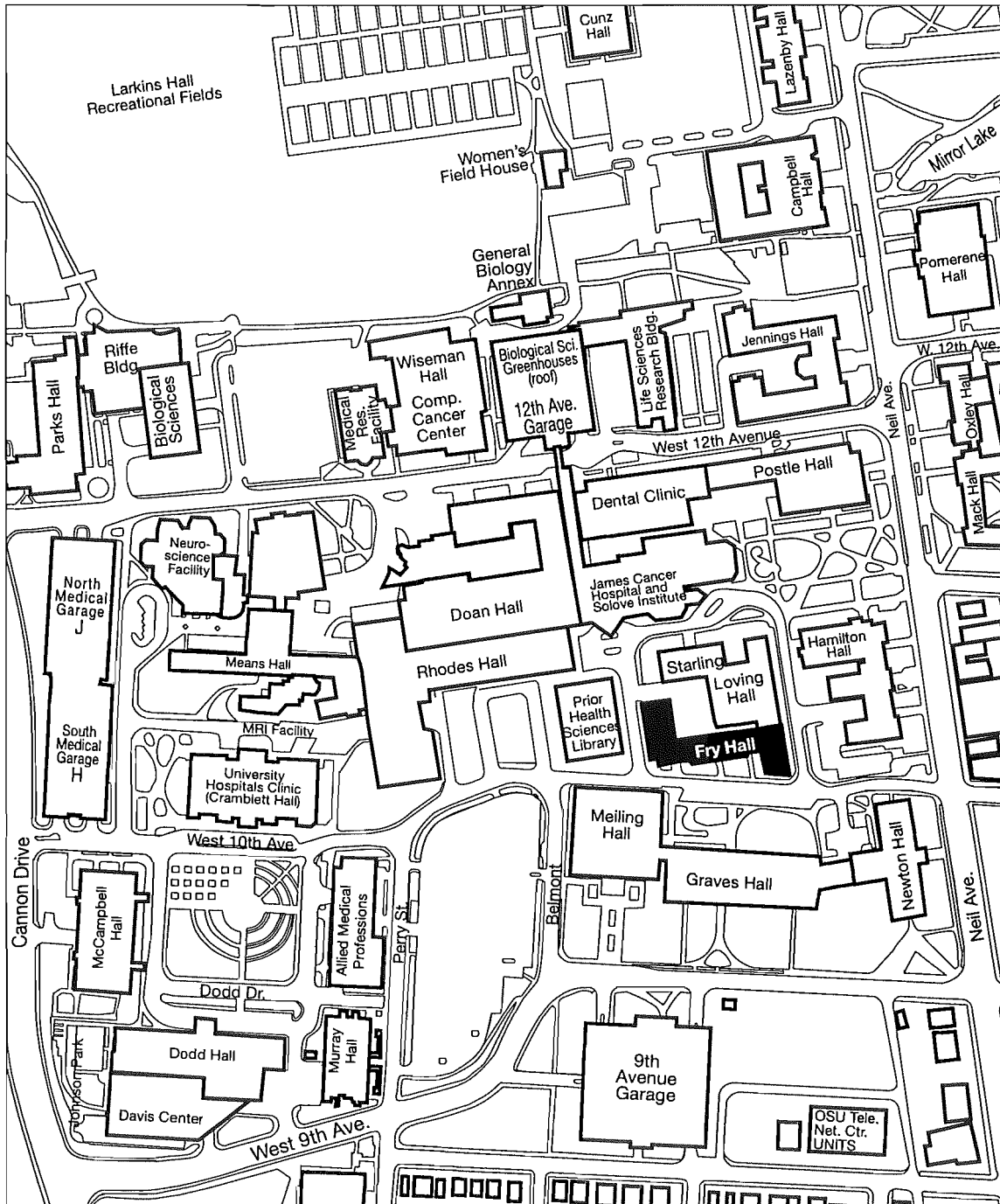

Office of Business and Finance
Office of Facilities Planning and Development

August 17, 2002

Medical Center Central Chilled Water Expansion

315-1999-939-5

PROJECT CAPTAIN:

Lori Seeger, Facilities Planning & Development - Architecture, 688-3757

REQUESTING AGENCY:

Health Sciences Administration

PROJECT LOCATION:

Various - see comments

AGE:**GR. SQ. FT.:****PROJECT DESCRIPTION:**

Create a first phase of a future central chilled water plant by increasing the capacity in the chilled water plant and piping for the Ross Heart Hospital. Chiller plants to be linked together in the future.

MILESTONES:

	Projected	Revised	Actual
Bidding Approved B/T	9/13/2002		
Schematic Design Approval	1/9/2002		
Design Dev. Document Approval	6/6/2002		
Construction Document Approval	12/3/2002		
Bid Opening	2/14/2003		
Award of Contracts	4/4/2003		
Construction Start	4/4/2003		
Report of Award to B/T	6/6/2003		
Completion	8/20/2004		

FUNDING INFORMATION:

Auxiliaries - Health Sciences	\$	2,827,975	
Auxiliaries - Ross Heart Hospital		1,569,725	
Total	\$	4,397,700	

USES:

Construction	\$	3,600,000	
Construction Manager		112,750	
Contingency		360,000	
Design		281,750	
Univ Administration		43,200	
Total	\$	4,397,700	

COMMENTS:

Site: Cramblett Hall, Rhodes Hall, and Ross Heart Hospital.

Health Sciences Quadrangle

315-1999-939-6

PROJECT CAPTAIN:

Lori Seeger, Facilities Planning & Development - Architecture, 688-3757

REQUESTING AGENCY:

Health Sciences Administration

PROJECT LOCATION:

Various - see comments

AGE:

GR. SQ. FT.:

PROJECT DESCRIPTION:

Design and implement the Health Sciences Quadrangle as per the south campus master plan.

MILESTONES:

	Projected	Revised	Actual
Bidding Approved B/T	9/13/2002		
Construction Document Approval	12/3/2002		
Bid Opening	1/24/2003		
Award of Contracts	3/14/2003		
Construction Start	3/14/2003		
Report of Award to B/T	12/1/2003		

FUNDING INFORMATION:

Auxiliaries - Health Sciences	\$	1,044,058		
Auxiliaries - Transportation & Parking		446,292		
Auxiliaries - Ross Heart Hospital		1,413,225		
Total	\$	2,903,575		

USES:

Construction	\$	2,347,909		
Construction Manager		72,600		
Contingency		234,791		
Design		220,100		
Univ Administration		28,175		
Total	\$	2,903,575		

COMMENTS:

Health Sciences area

Health Sciences Quadrangle

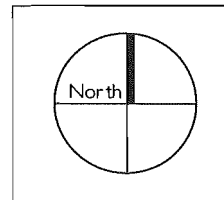
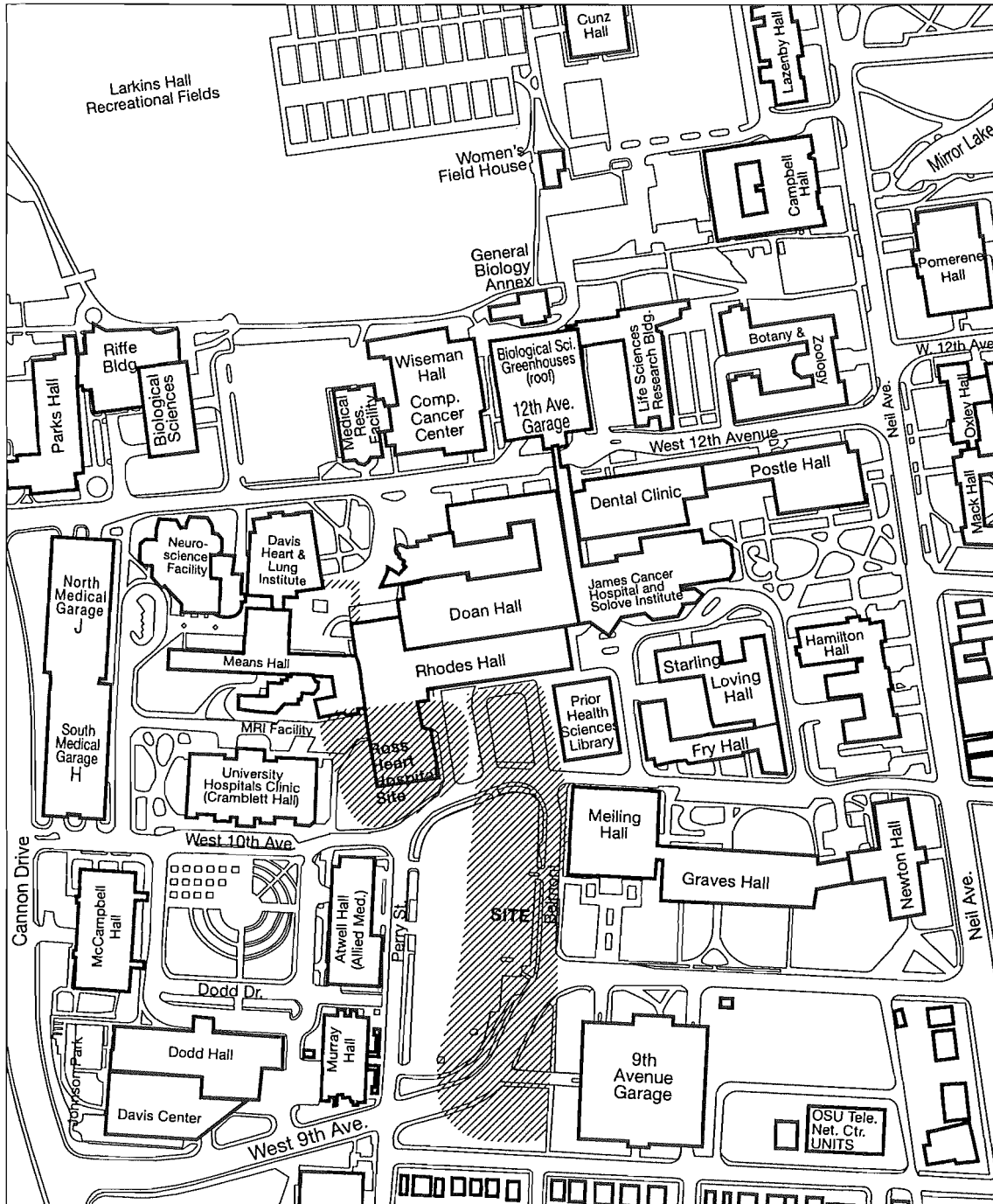

Office of Business and Finance
Office of Facilities Planning and Development

June 17, 2002

Davis Heart and Lung Institute - Basement**315-1993-401-2****PROJECT CAPTAIN:**

Steve Middleton, Facilities Planning & Development - Architecture, 688-3756

REQUESTING AGENCY:

Heart and Lung Research Institute

PROJECT LOCATION:

Davis Heart and Lung Research Institute

AGE:

2000

GR. SQ. FT.:

133,856

PROJECT DESCRIPTION:

Complete a portion of the shelled space in the basement to house laboratories and associated offices and equipment spaces.

MILESTONES:

	Projected	Revised	Actual
Bidding Approved B/T	9/13/2002		
Schematic Design Approval	8/21/2002		
Design Dev. Document Approval	11/11/2002		
Construction Document Approval	11/11/2002		
Bid Opening	1/31/2003		
Award of Contracts	2/18/2003		
Construction Start	2/19/2003		
Report of Award to B/T	3/7/2003		
Completion	7/22/2003		

FUNDING INFORMATION:

Development - Medicine	\$	1,163,625	
Total	\$	1,163,625	

USES:

Construction	\$	925,000	
Contingency		138,750	
Design		86,000	
Univ Administration		13,875	
Total	\$	1,163,625	

COMMENTS:

Formerly known as project 50700-R025174.

Wilce Student Health Center Renovation - Phase 2**315-2002-921****PROJECT CAPTAIN:**

Scott Conlon, Facilities Planning & Development - Architecture, 292-0983

REQUESTING AGENCY:

Student Health Services

PROJECT LOCATION:

Wilce Student Health Center, John W

AGE:

1970

GR. SQ. FT.:

53,768

PROJECT DESCRIPTION:

Renovate space on the first and third floors of the Wilce Student Health Center to provide new Physical Therapy and Clinical Laboratory space.

MILESTONES:

	Projected	Revised	Actual
Arch/Engr Approved by B/T	9/13/2002		
Bidding Approved B/T	9/13/2002		

FUNDING INFORMATION:

Future Univ Bond Issue	\$	1,113,360	
Total	\$	1,113,360	

USES:

Construction	\$	839,760	
Contingency		84,000	
Design		88,000	
Equipment		80,000	
Univ Administration		21,600	
Total	\$	1,113,360	

COMMENTS:

Formerly known as project 50700-R011650. Project schedule will be determined as a part of the programming phase.

Wilce Student Health Center Renovation - Phase 2

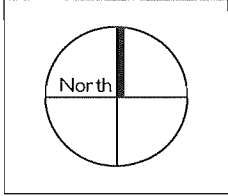
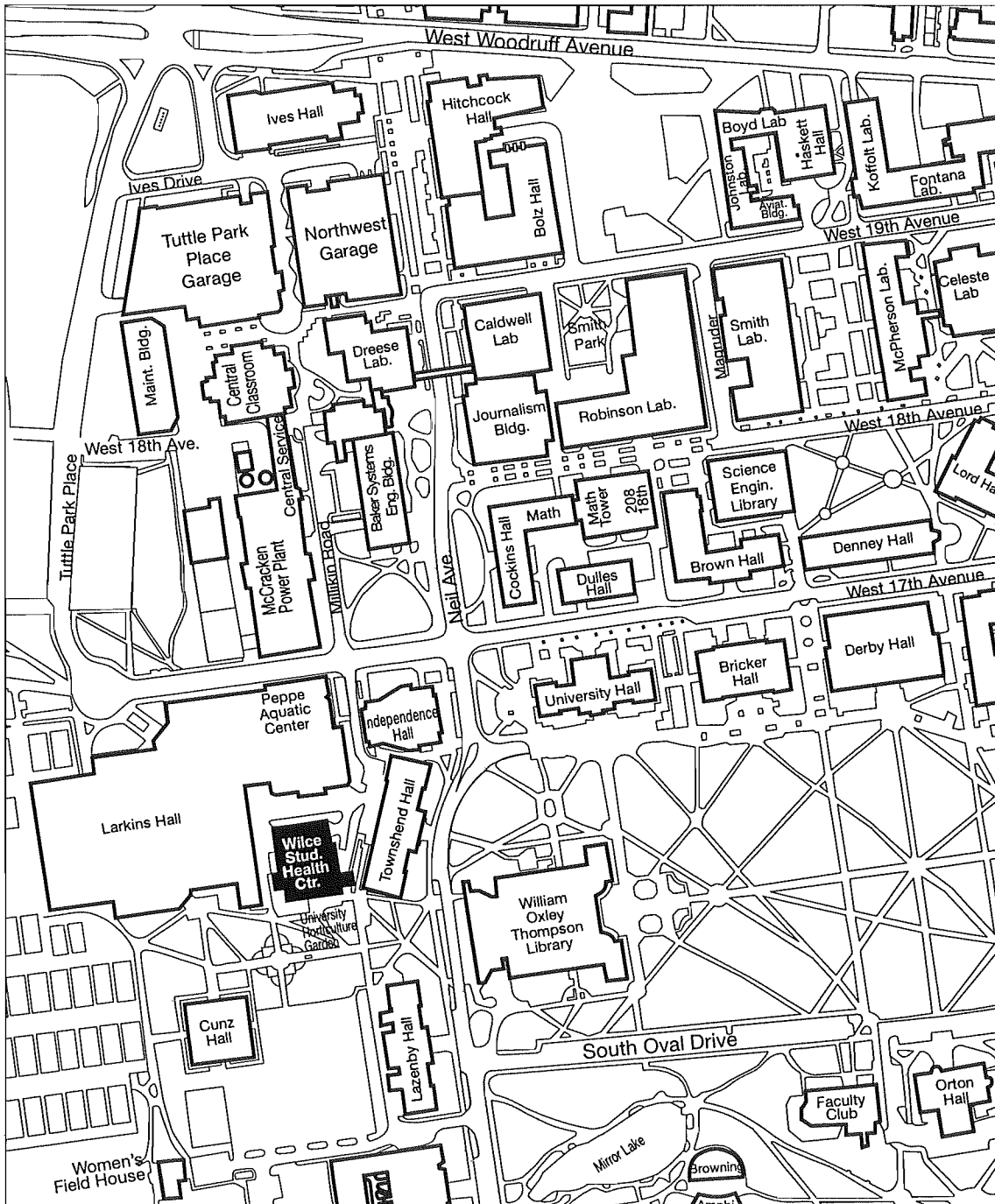

Office of Business and Finance
Office of Facilities Planning and Development

August 17, 2002

Graves Hall - ULAR Renovation

315-2002-920

PROJECT CAPTAIN:

Steve Middleton, Facilities Planning & Development - Architecture, 688-3575

REQUESTING AGENCY:

Office of Research

PROJECT LOCATION:

Graves Hall, Grant O.

AGE:

1969

GR. SQ. FT.:

220,370

PROJECT DESCRIPTION:

Renovate the Vivarium in Graves Hall.

MILESTONES:	Projected	Revised	Actual
Arch/Engr Approved by B/T	9/13/2002		
Bidding Approved B/T	9/13/2002		
Arch/Engr Contract	1/31/2003		
Schematic Design Approval	4/7/2003		
Design Dev Document Approval	4/7/2003		
Construction Document Approval	6/20/2003		
Bid Opening	7/28/2003		
Award of Contracts	9/22/2003		
Construction Start	10/9/2003		
Report of Award to B/T	12/5/2003		
Completion	1/1/2004		

FUNDING INFORMATION:

Other Restricted - Research	\$	246,392		
BoR Action Fund		189,443		
Grant - NIH	\$	378,885		
Total		\$814,720		

USES:

Construction	\$	667,698		
Contingency		70,237		
Design		66,770		
Univ Administration		10,015		
Total	\$	814,720		

COMMENTS:

Formerly known as project 50700-R021671.

Graves Hall - ULAR Renovations

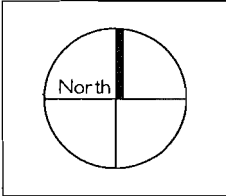
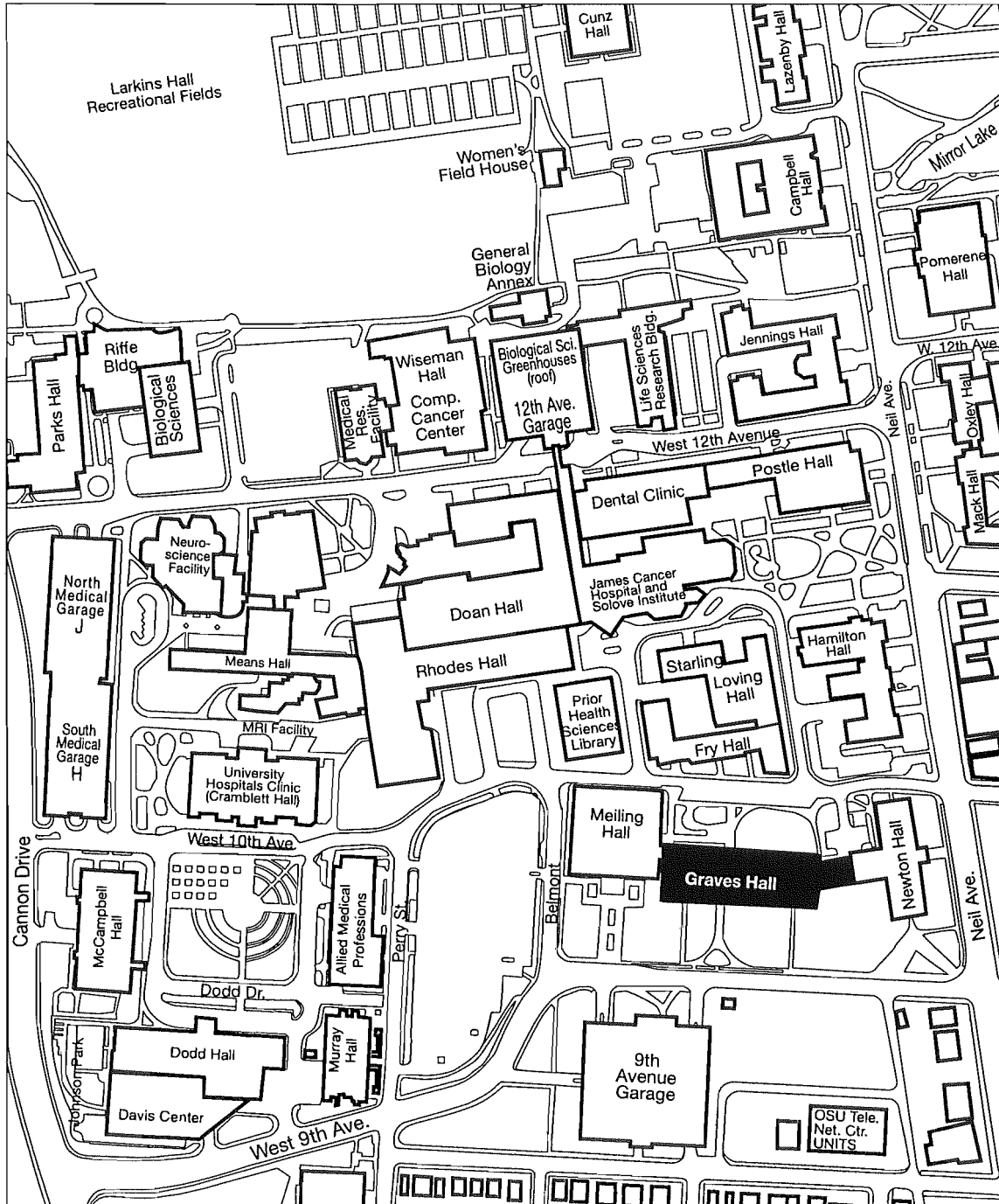

Office of Business and Finance
Office of Facilities Planning and Development

August 17, 2002

Women's Field House Relocation

9986-6746

PROJECT CAPTAIN:

Tricia Petra, Physical Facilities - Univ. Engineer's Office, 292-1349

REQUESTING AGENCY:

Department of Physical Facilities

PROJECT LOCATION:

Women's Field House

AGE:

1927

GR. SQ. FT.:

5,353

PROJECT DESCRIPTION:

Relocate the Women's Field House from south of Larkins Hall to each of Lincoln Tower for use as an educational classroom building. Project includes the installation of ADA restrooms and restoration of the exterior wood siding.

MILESTONES:

	Projected	Revised	Actual
Bidding Approved B/T	9/13/2002		
Construction Start	9/23/2002		
Report of Award to B/T	10/4/2002		
Completion	12/31/2002		

FUNDING INFORMATION:

Auxiliaries - Student Affairs	\$	17,000		
Earnings - Physical Facilities		354,935		
Repair and Renovation	\$	300,000		
Total		\$671,935		

USES:

Construction	\$	595,835		
Contingency		28,000		
Design		48,100		
Total	\$	671,935		

COMMENTS:

Women's Field House Relocation

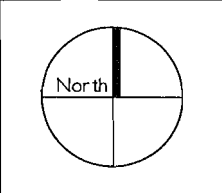
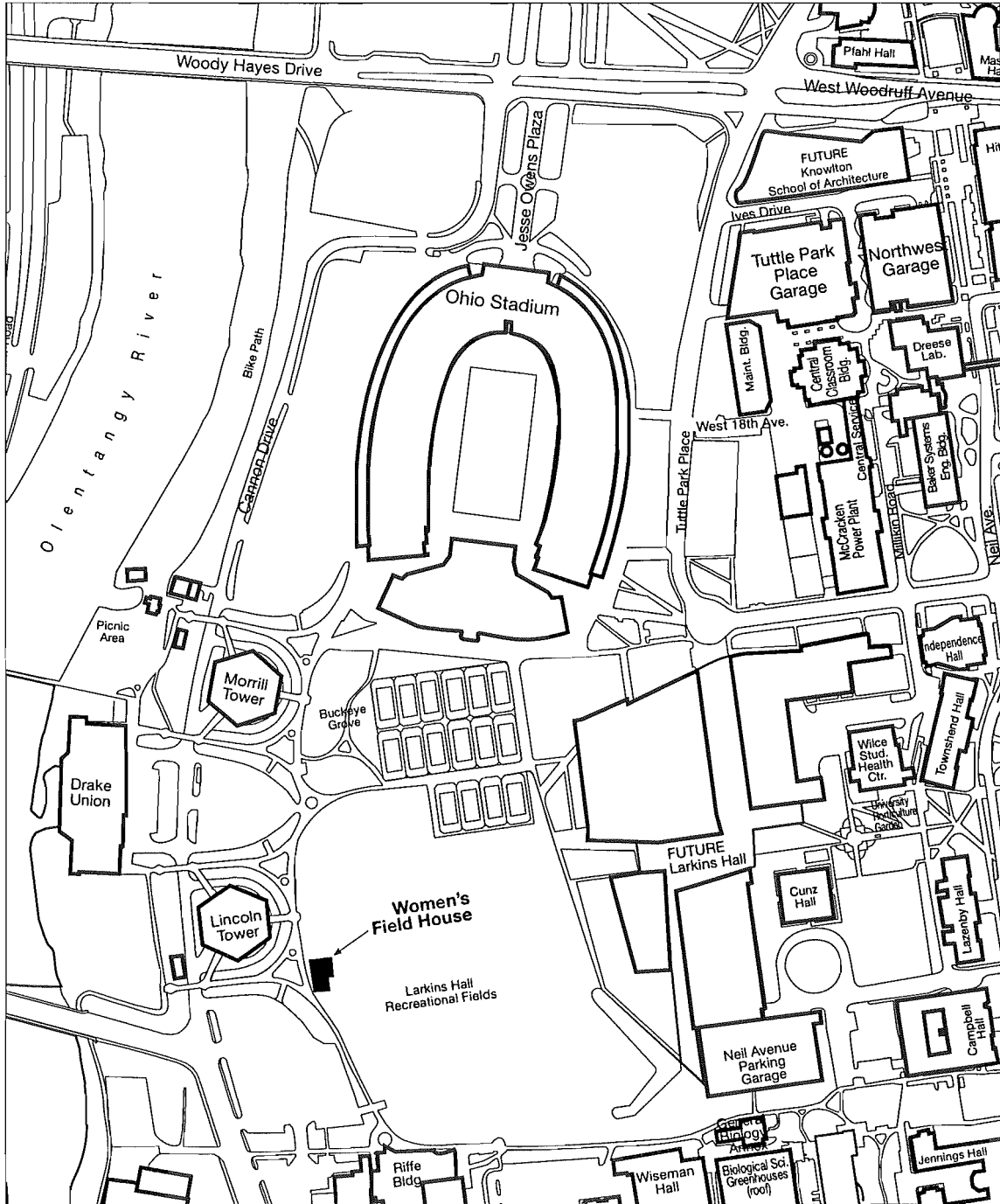

Office of Business and Finance
Office of Facilities Planning and Development

August 17, 2002

PROJECT CAPTAIN:

Sara Herridge, Facilities Planning & Development - Architecture, 292-0381

REQUESTING AGENCY:

Health Sciences Administration

PROJECT LOCATION:

Davis Heart and Lung Research Institute

AGE:

2000

GR. SQ. FT.:

133,856

PROJECT DESCRIPTION:

Renovate a portion of the shell space into research wet lab space.

MILESTONES:

	Projected	Revised	Actual
Bidding Approved B/T	9/13/2002		
Schematic Design Approval	9/30/2002		
Design Dev Document Approval	9/30/2002		
Construction Document Approval	11/20/2002		
Construction Start	12/21/2002		
Report of Award to B/T	12/6/2002		
Completion	5/19/2003		

FUNDING INFORMATION:

Development - Health Services	\$	398,812	
Total	\$	398,812	

USES:

Construction	\$	328,240	
Contingency		47,267	
Design		16,412	
Univ Administration		6,893	
Total	\$	398,812	

COMMENTS:

Formerly known as project 50700-R015122

Davis Heart and Lung Institute - Room 089

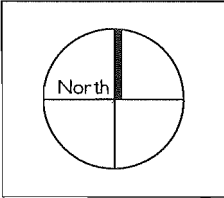
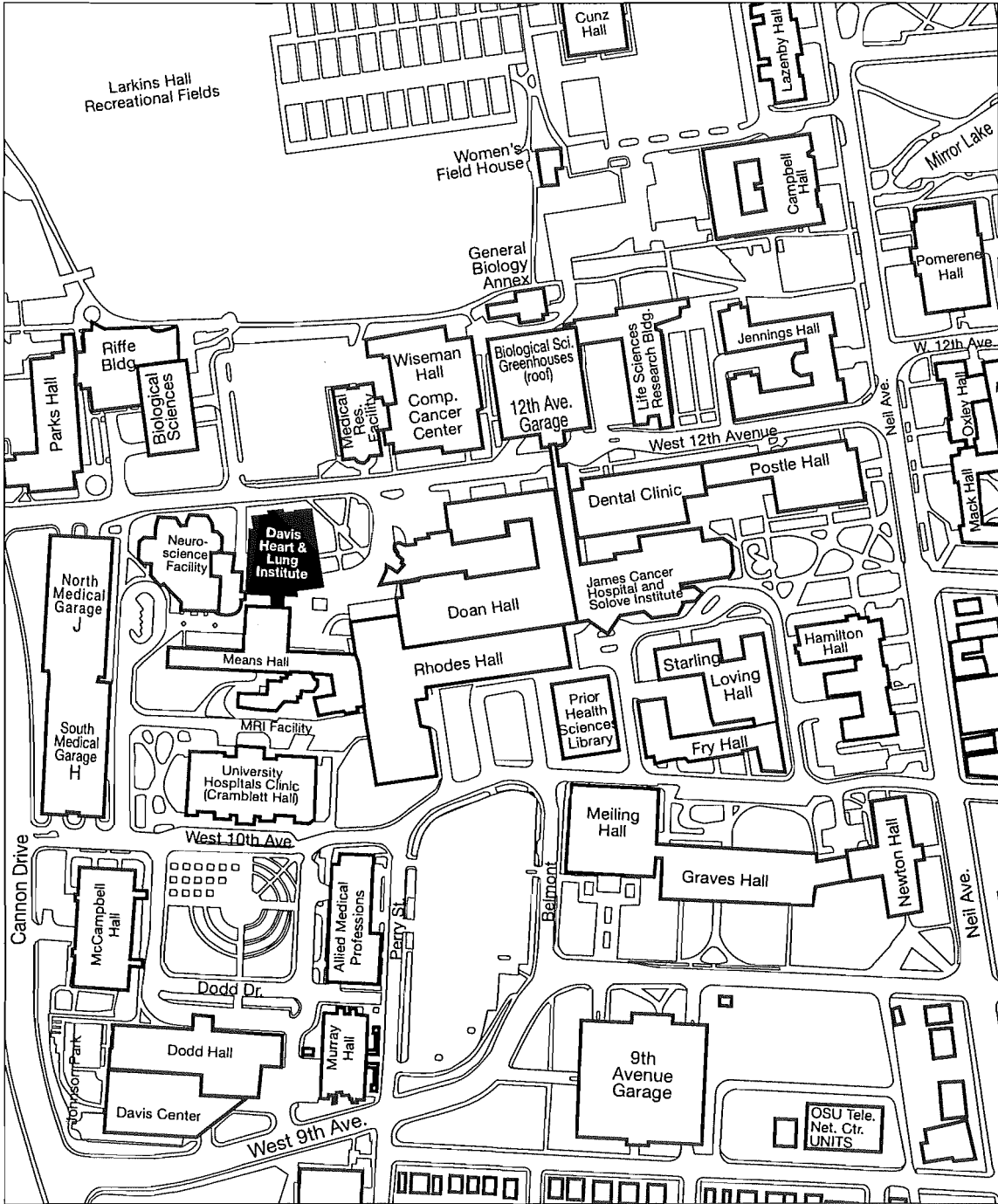

Office of Business and Finance
Office of Facilities Planning and Development

August 17, 2002

Pfahl Hall Executive Dining Room

315-2002-922

PROJECT CAPTAIN:

Jose Cueto, Student Affairs, 292-0654

REQUESTING AGENCY:

Student Affairs

PROJECT LOCATION:

Pfahl Executive Education Building, John K.

AGE:

1999

GR. SQ. FT.:

58,054

PROJECT DESCRIPTION:

Provide renovation of the present executive dining room in Pfahl Hall. Pfahl Hall serves the Fisher College of Business Executive Education program.

MILESTONES:

	Projected	Revised	Actual
Arch/Engr Approved B/T	9/13/2002		
Bidding Approved B/T	9/13/2002		
Schematic Design Approval	10/30/2002		
Design Dev Document Approval	11/30/2002		
Construction Document Approval	12/30/2002		
Bid Opening	2/6/2003		
Award of Contracts	3/28/2003		
Construction Start	3/31/2003		
Report of Award to B/T	12/5/2003		
Completion	7/31/2003		

FUNDING INFORMATION:

Auxiliaries - Student Affairs	\$	494,700		
Total	\$	494,700		

USES:

Construction	\$	417,500		
Contingency		41,170		
Design		33,400		
Univ Administration		2,630		
Total	\$	494,700		

COMMENTS:

Pfahl Hall Executive Dining Room

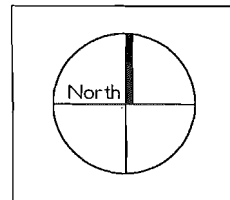
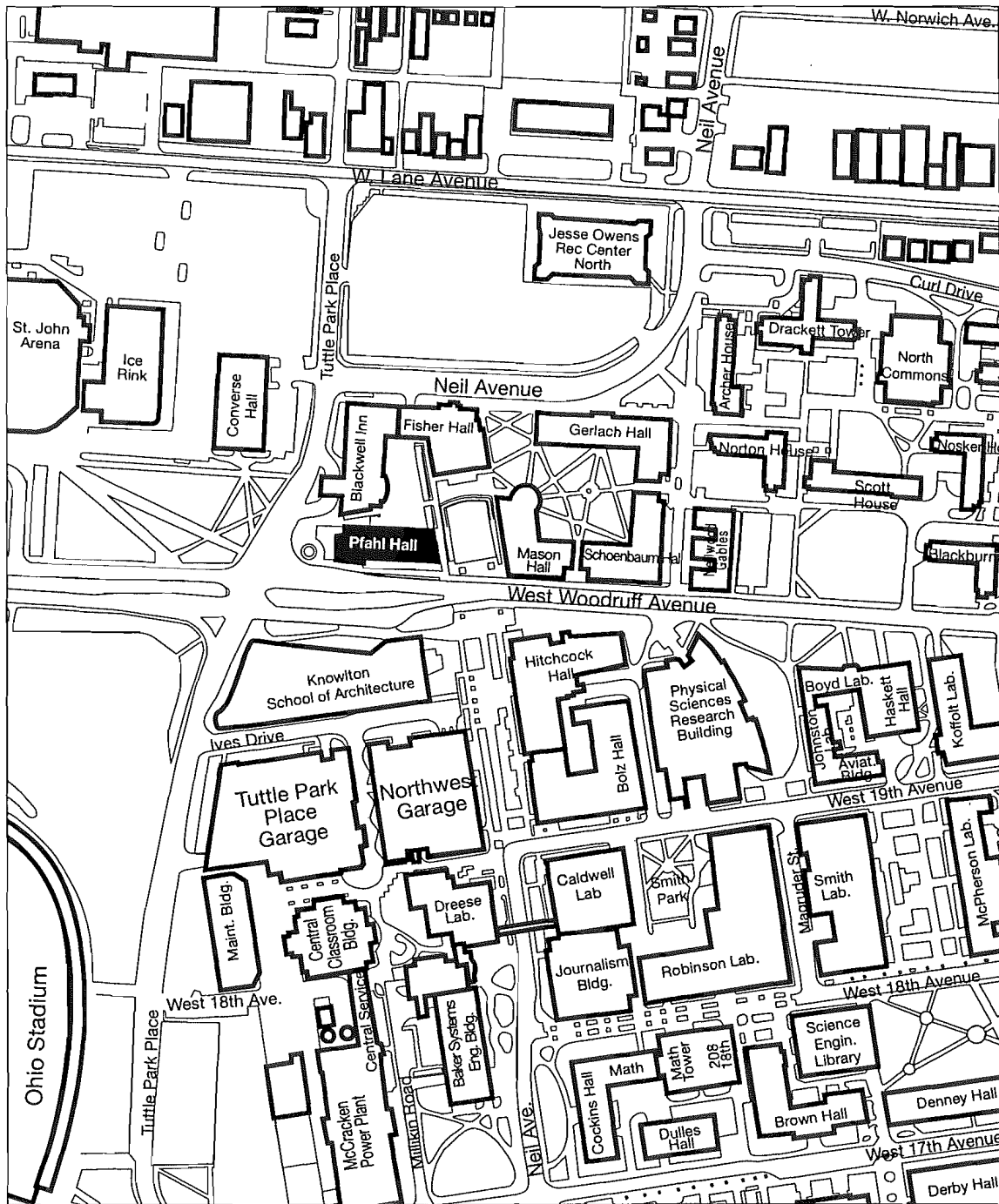

Office of Business and Finance
Office of Facilities Planning and Development

August 17, 2002

Tzagournis - MRI and Research Lab

50700-R025161

PROJECT CAPTAIN:

Sara Herridge, Facilities Planning & Development - Architecture, 292-0381

REQUESTING AGENCY:

College of Medicine and Public Health

PROJECT LOCATION:

Tzagournis Medical Research Facility

AGE:

1994

GR. SQ. FT.:

78,705

PROJECT DESCRIPTION:

Remodel three rooms on the ground floor of the Tzagournis Medical Research Facility to house an MRI and related research lab. Additional power will be brought from the penthouse to the first floor and additional structural modifications to the first floor slab to accommodate this MRI unit is required.

MILESTONES:

	Projected	Revised	Actual
Arch/Engr Approved B/T	9/13/2002		
Bidding Approved B/T	9/13/2002		
Schematic Design Approval	9/30/2002		
Design Dev Document Approval	9/30/2002		
Construction Document Approval	11/20/2002		
Construction Start	11/28/2002		
Report of Award to B/T	12/6/2002		
Completion	1/28/2003		

FUNDING INFORMATION:

General Funds - Medicine	\$	312,270	
Total	\$	312,270	

USES:

Construction	\$	250,000	
Contingency		32,020	
Design		25,000	
Univ Administration		5,250	
Total	\$	312,270	

COMMENTS:

Tzagournis - MRI and Research Lab

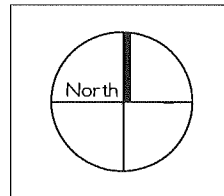
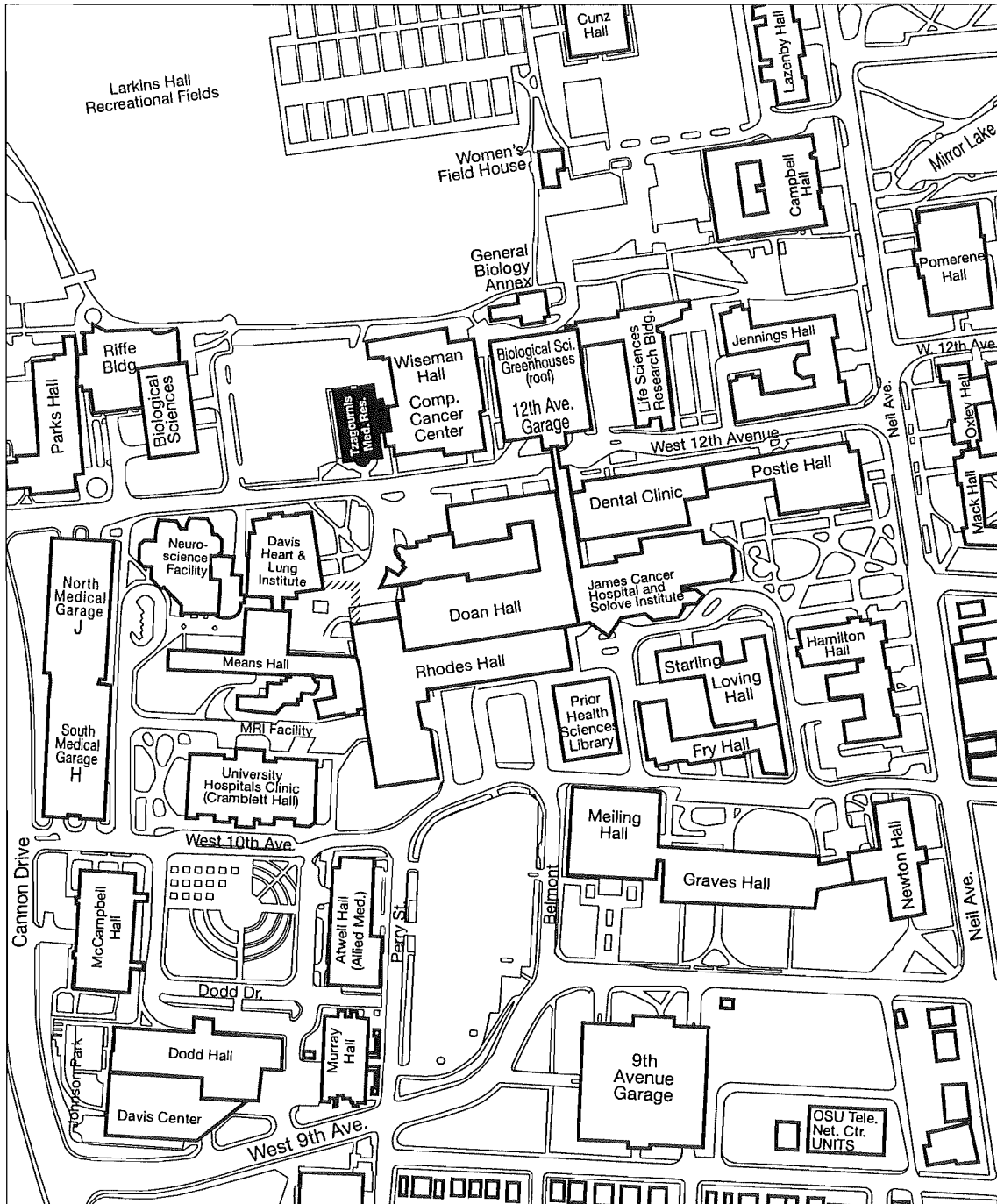

Office of Business and Finance
Office of Facilities Planning and Development

August 17, 2002

PROJECT CAPTAIN:

Denise Beard, Facilities Planning & Development - Architecture, 292-0163

REQUESTING AGENCY:

College of Law

PROJECT LOCATION:

Drinko Hall, John Deaver

AGE:

1956

GR. SQ. FT.:

220,112

PROJECT DESCRIPTION:

Renovation and modernization of the Moritz College of Law Courtrooms to accommodate contemporary modes of trial practice instruction, actual trials, and state-of-the-art instructional and courtroom technology.

MILESTONES:

	Projected	Revised	Actual
Arch/Engr Approved B/T	9/13/2002		
Bidding Approved B/T	9/13/2002		
Schematic Design Approval	3/1/2003		
Design Dev Document Approval	3/1/2003		
Construction Document Approval	5/30/2003		
Bid Opening	7/1/2003		
Construction Start	9/1/2003		
Report of Award to B/T	12/5/2003		
Completion	1/31/2004		

FUNDING INFORMATION:

General Funds - Law	\$	300,000		
Total	\$	300,000		

USES:

Construction	\$	250,000		
Contingency		19,750		
Design		25,000		
Univ Administration		5,250		
Total	\$	300,000		

COMMENTS:

Formerly known as 50700-R021679

Drinko Hall - Room 249

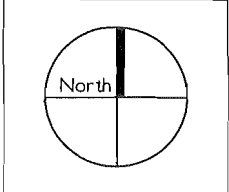
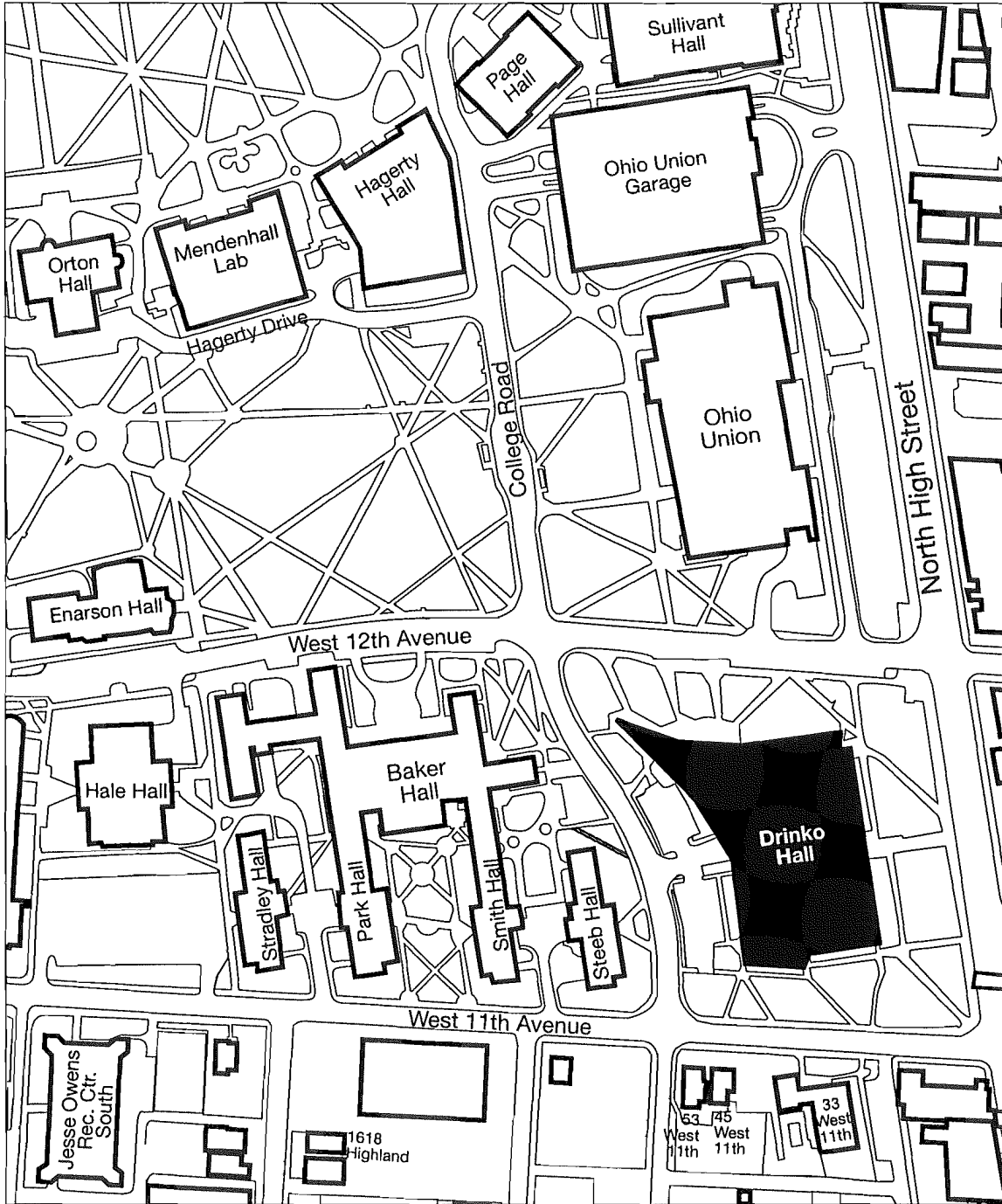

Office of Business and Finance
Office of Facilities Planning and Development

August 17, 2002

(APPENDIX XVIII)

SALE OF REAL PROPERTY

1375 SOUTH HAMILTON ROAD
COLUMBUS, OHIO

Location and Description

The property to be sold is an undivided one-half interest in a two-story medical building of 12,440 square feet on approximately 0.65 acres located close to the corner of South Hamilton Road and East Livingston Avenue in Columbus, Ohio. The 33-year old building is in poor condition, with significant deferred maintenance. It is occupied by one tenant, who uses approximately 1,900 square feet of office space. The property is titled in the name of the Board of Trustees of The Ohio State University as a part of the University Endowment holdings.

The owner of the other undivided one-half interest, Dr. Martin Robbins, has agreed to sell the property in conjunction with the University. The purchaser is DeMarco, Inc., a private corporation.

Appraisal and Purchase Price

An MAI appraisal conducted by Mollica Appraisal Company in July 2002 valued the property at \$200,000. The purchaser has agreed to purchase the property at a price of \$202,000. The Endowment is liquidating certain of its real estate holdings as a matter of routine review and improvement of its portfolio. Proceeds will be reinvested in the Endowment.

Sale of Commercial Property 1375 South Hamilton Road

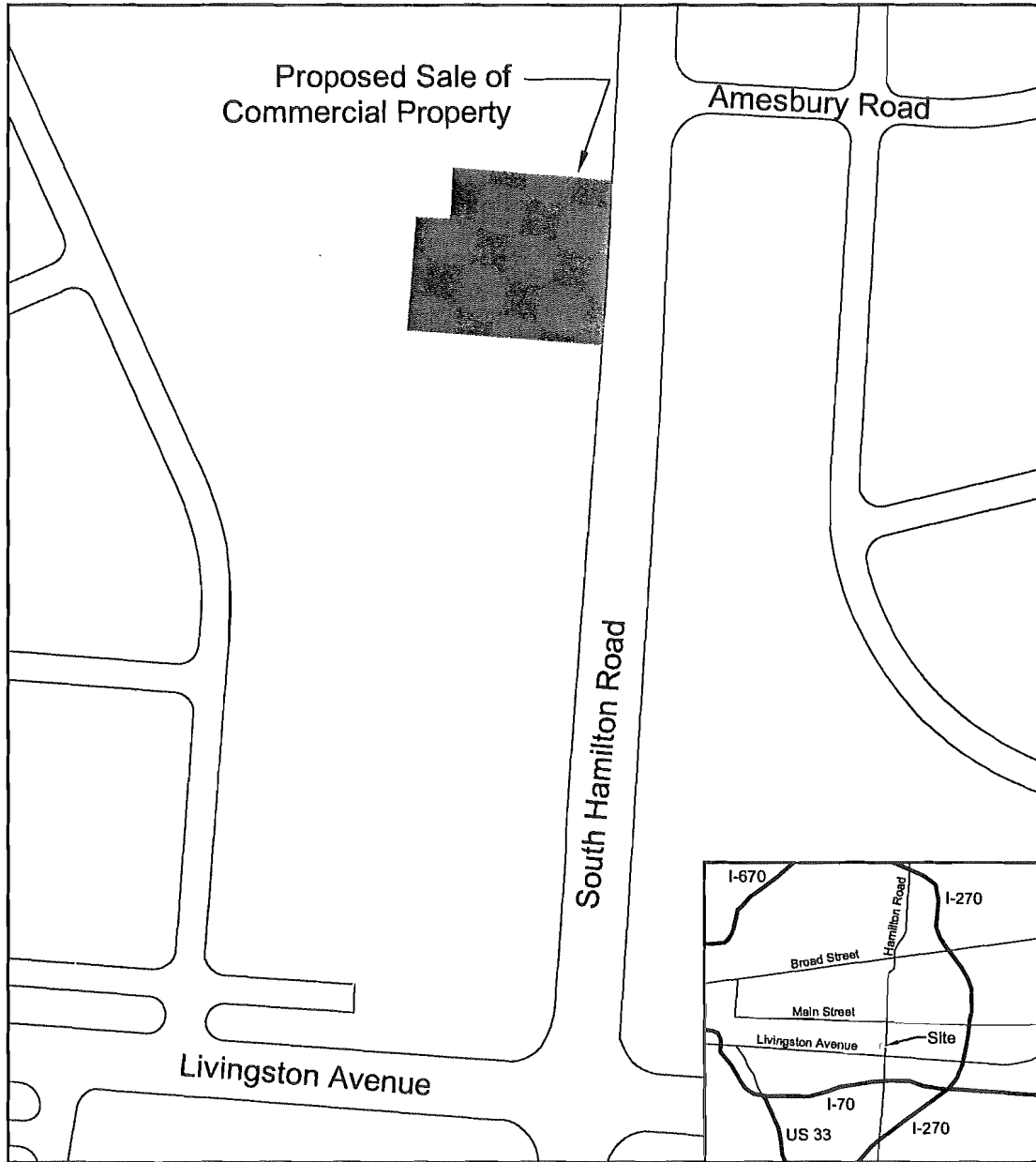

No True Scale

Office of Business and Finance
September 6, 2002



 Proposed Sale of
Commercial Property

Map Provided by University Engineer's Office

Executive Summary

In June 2001, President William E. Kirwan established a 16-member Presidential Commission on the Regional Campuses and charged it to address a variety of issues relating to mission/governance, admissions/enrollment, students/student services, and faculty and curriculum. This Report addresses selected, broad issues that affect all campuses, and it focuses on a set of recommendations that can be acted upon immediately and then others that need further long-term discussion, analysis, and action. This Report does **not** address issues that are specific to a particular Regional Campus.

General Recommendations

- **clarify and specify why the University has and needs Regional Campuses.**

They provide access to higher education in general, and to The Ohio State University specifically, for Ohio citizens who would otherwise be un-served; they establish a formal geographical presence for the University outside Columbus, in the small cities and the multiple-county regions that each serves; they enhance economic development in their regions of the state; and they strengthen the learning and cultural opportunities within the local community, notably through their outreach and engagement activities.

Action: Office of Academic Affairs/Office of Communication
Timeline: AU/02 and continuing

- **establish, immediately, stronger internal (intra-University) “system” operations than currently exist in many administrative areas.**

The Regional Campuses are an integral part of the University, but now need to begin to function that way more fully in systemic terms.

Action: Office of Academic Affairs
Timeline: AU/02 and continuing

I: Recommendations for Immediate Action

Mission and Governance

- revise the University’s “vision” statement, within the Academic Plan, to: alter the statement to note “on each of our campuses” or “on all campuses” where appropriate; indicate formally that the Regional Campuses will expand the reach of the University’s missions and serve as valuable resources to each region in Ohio, and will offer courses and a select number of degree programs from the University curriculum; indicate

formally that they will provide entry for students who may not otherwise have access to Ohio State, and will prepare them to successfully complete degrees

- revise the By-laws of the Regional Campus Boards of Trustees to introduce a more structured nomination and selection process; better educate and communicate directly and more consistently with local board members; and to seek financial synergies across Regional Campuses rather than only with co-located technical colleges.

Action: Board of Trustees

Timeline: AU/02

- the Executive Vice President and Provost should review the current pattern of interactions between the Vice Provosts and the Regional Campuses and determine how, administratively, coordination will be improved. The result should in no way interfere with the current pattern of the dean/director having direct access to the Provost when needed.

Action: Office of Academic Affairs

Timeline: AU/02

Admissions/Enrollment

All Recommendations

Action: Office of Academic Affairs/Office of Enrollment Services

Timeline: AU/02 and continuing

Application

- Revise the application for admission: ask students to indicate both a first-choice and an alternate choice-campus
- Revise the options letter to Ohio residents denied admission to the Columbus campus. Ohio residents not admissible to the Columbus campus who have indicated an alternate-choice campus will get a letter emphasizing their admission to their alternate choice campus, rather than their inadmissibility to Columbus. Students not admitted to Columbus who do not indicate an alternate campus will receive a letter similar to the current denial/options letter, one that emphasizes enrollment at a Regional Campus as the best option. The wording for this letter will be composed by Undergraduate Admissions in Columbus and approved by Regional Campus colleagues.

Campus Change

- With the exception of students whose high school credentials qualify them for admission to the Columbus campus, students beginning on a Regional Campus/ATI must complete a full year (45 quarter hours) before changing to the Columbus campus.

Future Admissions Policies

- establish principles for future admissions policies: If a Regional Campus cannot accommodate demands for academic resources, then the following priorities should guide admission policies for each Regional Campus: open admission for Ohio residents; if a Regional Campus reaches enrollment capacity then increased selective admissions criteria should be used for non-residents, and all interested Ohio residents should be admitted using open admissions criteria.

Advising

- Advising should continue to be University-focused. The advising system at present seems to be functioning well. Efforts should be made to ensure that the advising on which campus to attend continues to put the needs of the student before the needs of the particular campus.
- efforts should be made to follow-up, in a more systematic way, with students who have moved to Columbus, to gather information on the adjustment process. That information should then be used to help future students with the transition.

Marketing and Recruiting

- develop recruitment messages relating to the special nature of the Regional Campuses. Undergraduate Admissions and First Year Experience should use these messages in collaboration with University Marketing Communications as a guide in producing promotional communications about the University and its Regional Campuses.

Enrollment Projections

- As these five growth opportunities evolve simultaneously, a sophisticated Regional Campus enrollment projection process must be developed and implemented as soon as possible, to include: projections for demand from all regions of Ohio for increased residential and student life opportunities; demand for new four-year degree programs; demand for satellite operations and distance education opportunities; and for enrollment from applicants not admitted to the Columbus campus.

II: Recommendations for Longer-Term Discussion and Action

Students and Student Services

- the University should adopt the University-owned and managed approach to student housing on the Regional campuses. This approach may take longer and the costs will be higher, but the University has experience in such activity and is attuned to the importance of establishing appropriate academic housing needs.

Action: Regional Campuses, Office of Academic Affairs; Office of Business and Finance; Office of Student Affairs

Timeline: AU02 and continuing

- the University adopt the Collaboration Model for student services on the Regional Campuses and that an Action Plan that addresses funding, space and facilities, and implications of co-location be drafted as soon as possible.

Action: Regional Campuses, Office of Academic Affairs, Office of Student Affairs

Timeline: AU/02 – SP/03

Faculty and Curriculum

- the University should adhere to the “one University” model for faculty and curriculum and should continue to work toward its achievement. It is important to note that this model does not require that all of the campuses be identical in all respects. This would neither be possible nor desirable. But, it does require that a core set of criteria and standards be defined, and that a “range of comparability” across campuses with respect to standards and criteria be identified.
- the University should explore, immediately, in more detail, approaches adopted by other universities, to determine if they could provide creative alternatives to some of the issues that need to be addressed in the “one University” model.

Action: Regional Campuses, Office of Academic Affairs

Timeline: AU/02 and continuing

- The Regional Campuses and the Office of Academic Affairs should now determine the feasibility of: expanding the number of bachelor degree programs currently only offered in Columbus, to the Regional Campuses; developing new degree programs that address the unique needs/features of the Regional Campuses and are specific to the Regional Campuses; developing specific degree programs on specific campuses and sharing them among all campuses.

Use of distance learning and other technologies to make a wider variety of majors available to Regional Campus students should be an important consideration in programmatic expansion.

- the Regional Campuses and the Office of Academic Affairs should also assess whether Regional Campuses should offer certificate programs, and analyze the status of its associate degrees programs.

Action: Office of Academic Affairs; Regional Campuses
Timeline: AU/02 and continuing

Co-Location

- the University administration should begin to monitor more closely issues that are related to co-location and determine their effect on Regional Campus planning.

Action: Board of Trustees; Office of the President; Office of Academic Affairs
Timeline: AU/02 and Continuing

Presidential Commission on the Regional Campuses

Final Report

August 2002

Commission Membership

Bobby D. Moser, Vice President for Agricultural Administration and University Outreach, and Commission Chair

Leslie A. Beyer-Hermsen, Assistant Dean, OSU-Marion

Professor Graeme M. Boone, School of Music, College of the Arts

Thomas A. Brannon, Chair, Board of Trustees, Newark

Professor Terri D. Fisher, OSU-Mansfield (Psychology)

Robert Gold, Dean, College of Mathematical and Physical Sciences

Professor John M. Hellmann, OSU-Lima (English)

Karen L. Hendricks, Board of Trustees

James J. Mager, Associate Vice President, Enrollment Services

James F. Patterson, Chair, Board of Trustees

Professor Richard E. Petty, Chair, Department of Psychology

John O. Riedl, Dean/Director, OSU-Mansfield, Coordinating Dean, Regional Campuses

Shellie R. Shirk, Undergraduate Student, OSU-Marion

W. Randy Smith, Vice Provost, Office of Academic Affairs

Professor R. Vladimir Steffel, OSU-Marion (History)

Professor Matthew B. Stenzel, OSU-Newark (Mathematics)

Diane S. Whitbeck, Associate Vice President, Housing and Student Services

Executive Summary

In June 2001, President William E. Kirwan established a 16-member Presidential Commission on the Regional Campuses and charged it to address a variety of issues relating to mission/governance, admissions/enrollment, students/student services, and faculty and curriculum. This Report addresses selected, broad issues that affect all campuses, and it focuses on a set of recommendations that can be acted upon immediately and then others that need further long-term discussion, analysis, and action. This report does **not** address issues that are specific to a particular Regional Campus.

General Recommendations

- **clarify and specify why the University has and needs Regional Campuses.**

They provide access to higher education in general, and to The Ohio State University specifically, for Ohio citizens who would otherwise be un-served; they establish a formal geographical presence for the University outside Columbus, in the small cities and the multiple-county regions that each serves; they enhance economic development in their regions of the state; and they strengthen the learning and cultural opportunities within the local community, notably through their outreach and engagement activities.

- **establish, immediately, stronger internal (intra-University) “system” operations than currently exist in many administrative areas.**

The Regional Campuses are an integral part of the University, but now need to begin to function that way more fully in systemic terms.

I: Recommendations for Immediate Action

Mission and Governance

- revise the University’s “vision” statement, within the Academic Plan, to: alter the statement to note “on each of our campuses” or “on all campuses” where appropriate; indicate formally that the Regional Campuses will expand the reach of the University’s missions and serve as valuable resources to each region in Ohio, and will offer courses and a select number of degree programs from the University curriculum; - indicate formally that they will provide entry for students who may not otherwise have access to the University, and will prepare them to successfully complete degrees (Appendix I).
- revise the By-laws of the Regional Campus Boards of Trustees to introduce a more structured nomination and selection process; better

educate and communicate directly and more consistently with local board members; and to seek financial synergies across Regional Campuses rather than only with co-located technical colleges (Appendix II).

- the Executive Vice President and Provost should review the current pattern of interactions between the Vice Provosts and the Regional Campuses and determine how, administratively, coordination will be improved. The result should in no way interfere with the current pattern of the dean/director having direct access to the Provost when needed.

Admissions/Enrollment

Application

- Revise the application for admission: ask students to indicate both a first-choice and an alternate choice-campus
- Revise the options letter to Ohio residents denied admission to the Columbus campus. Ohio residents not admissible to the Columbus campus who have indicated an alternate-choice campus will get a letter emphasizing their admission to their alternate choice campus, rather than their inadmissibility to Columbus. Students not admitted to Columbus who do not indicate an alternate campus will receive a letter similar to the current denial/options letter, one that emphasizes enrollment at a Regional Campus as the best option. The wording for this letter will be composed by Undergraduate Admissions in Columbus and approved by Regional Campus colleagues.

Campus Change

- with the exception of students whose high school credentials qualify them for admission to the Columbus campus, students beginning on a Regional Campus/Agricultural Technical Institute (ATI) must complete a full year (45 quarter hours) before changing to the Columbus campus.

Future Admissions Policies

- establish principles for future admissions policies: if a Regional Campus cannot accommodate demands for academic resources, then the following priorities should guide admission policies for each regional campus: open admission for Ohio residents; if a Regional Campus reaches enrollment capacity, then increased selective admissions criteria should be used for non-residents, and all interested Ohio residents should be admitted using open admission criteria.

Advising

- Advising should continue to be University-focused. The advising system at present seems to be functioning well. Efforts should be made to ensure that the advising on which campus to attend continues to put the needs of the student before the needs of the particular campus.
- efforts should be made to follow-up, in a more systematic way, with students who have moved to Columbus, to gather information on the adjustment process. That information should then be used to help future students with the transition.

Marketing and Recruiting

- develop recruitment messages relating to the special nature of the Regional Campuses. Undergraduate Admissions and First Year Experience should use these messages in collaboration with University Marketing Communications as a guide in producing promotional communications about the University and its Regional Campuses.

Enrollment Projections

- As these five growth opportunities evolve simultaneously, a sophisticated Regional Campus enrollment projection process must be developed and implemented as soon as possible, to include: projections for demand from all regions of Ohio for increased residential and student life opportunities; demand for new four-year degree programs; demand for satellite operations and distance education opportunities; and for enrollment from applicants not admitted to the Columbus campus.

II: Recommendations for Longer-Term Discussion and Action

Students and Student Services

- the University should adopt the University-owned and managed approach to student housing on the Regional Campuses. This approach may take longer and the costs will be higher, but the University has experience in such activity and is attuned to the importance of establishing appropriate academic housing needs.

- the University should adopt the Collaboration Model for student services on the Regional Campuses and an Action Plan that addresses funding, space and facilities, and implications of co-location, be drafted as soon as possible.

Faculty and Curriculum

- the University should adhere to the “one University” model for faculty and curriculum and should continue to work toward its achievement. It is important to note that this model does not require that all of the campuses be identical in all respects. This would neither be possible nor desirable. But, it does require that a core set of criteria and standards be defined, and that a “range of comparability” across campuses with respect to standards and criteria be identified.
- the University should explore, immediately, in more detail, the approaches adopted at other universities, to determine if they could provide creative alternatives to some of the issues that need to be addressed in the “one University” model.
- The Regional Campuses and the Office of Academic Affairs should now determine the feasibility of: expanding the number of bachelor degree programs currently only offered in Columbus, to the Regional Campuses; developing new degree programs that address the unique needs/features of the Regional Campuses and are specific to the Regional Campuses; developing specific degree programs on specific campuses and sharing them among all campuses.

Use of distance learning and other technologies to make a wider variety of majors available to Regional Campus students should be an important consideration in programmatic expansion.

- the Regional Campuses and the Office of Academic Affairs should also assess whether Regional Campuses should offer certificate programs, and analyze the status of associate degree programs.

Co-Location

- the University administration should begin to monitor more closely issues that are related to co-location and determine their effects on Regional Campus planning.

Presidential Commission on the Regional Campuses
Final Report
August 2002

I: Introduction

The Ohio State University has four “regional campuses” (Faculty Rule 3335-1-05 (I)) located in Lima, Mansfield, Marion and Newark, Ohio. Since their establishment four decades ago, individually and collectively they have developed a distinctive niche within the University’s organizational and academic structure.

Although the mission of these campuses has been continuously evolving, today they are at an important stage of their development. More than ever before it is necessary to provide a more formal plan for their future. These campuses will always need to continue to respond to the changing needs of their local communities. However at least two other contextual issues now need to be confronted.

First, and most importantly, where do they “fit” within the academic planning processes underway within the University, particularly with the adoption of the Academic Plan (2000)? The Plan includes a strategy to “enhance and better serve the student body”, and specifies the goal to “within the next three years, make admission to Ohio State selective throughout the year for new freshmen and for transfer students”. When implemented for the Columbus campus, this action will have impacts on the Regional Campuses. They will remain “open admission”, but the characteristics and needs of their students will begin to change. We must now identify and address the issues that emerge as these changes take place.

Second, and simultaneously, how must the mission of the Regional Campuses align with the changing higher education landscape at the State level, particularly the changing nature of the entire two-year sector, the growing attention to issues of transfer and articulation, and the increased use of distance/distributed learning?

Over the past decade, the entire higher education system itself in Ohio has been changing. With a growing emphasis on “access”, there has occurred “mission revision” at all levels of the network of universities and community and technical colleges. For example, technical colleges have added general liberal arts courses to their technical curricula, and some have converted to community colleges. At the same time, detailed transfer and articulation agreements and “transfer modules” have been developed for each of the universities, and community and technical colleges. The goal is to make “transfer” easier for more students. These situations result in changing working relationships between and among institutions – something of particular importance to The Ohio State University, given that all four of our Regional Campuses are co-located with a technical college.

Moreover, the past decade has seen the growing acceptance and use of distance/distributed learning. Courses and programs need not be offered on site. This

changes the relationships of what and how courses and programs can be offered, not only between the Columbus Campus and the Regional Campuses, but also among the Regional Campuses, and between and among other universities and our co-located campuses. This represents a new instructional environment that can shape what courses and programs we offer on our Regional Campuses.

An important new era in the development of our Regional Campuses has begun. We need to plan for it.

II: The Charge to the Commission

Given these considerations, early in 2001, the Office of Academic Affairs, working with the administrative leadership of the Regional Campuses, and with input from faculty and staff at each campus, prepared a working paper: The Ohio State University Regional Campuses: Future Development Issues (June 2001) that outlined major issues for further analysis and action.

In June 2001, President William E. Kirwan established a Presidential Commission on the Regional Campuses with the working paper offered as a resource document.

Chaired by Bobby D. Moser, Vice President for Agricultural Administration and University Outreach, the Commission was composed of 16 members: 2 members of the University Board of Trustees; 8 representatives from the Regional Campuses (four faculty members, one student, two administrators, and one Regional Campus Board of Trustee member); and 6 representatives from the Columbus campus, (a Dean, a department chair, and four senior administrators who have responsibility for an area that relates to the Regional Campuses).

The President charged the Commission to address the following questions:

- How well is the current admissions process at the regional campuses integrated with the process on the main campus? Would the University be better served with a single multi-campus admission process?
- How well does the articulation process between the regional campuses and the main campus work? What steps if any need to be taken to improve the process?
- Are the roles and functions of the boards of the regional campuses sufficiently well defined? Are changes in those roles needed? Is communication between the regional boards, university administration, and the Board of Trustees adequate?
- What role should the regional campuses play in offering four year degrees?
- Are the regional campuses and the main campus making appropriate use of distance education in serving the needs of the regional campus students?

- Are the residential and extracurricular needs of the students at the regional campuses being adequately met?
- What issues will need to be of concern to faculty if the mission of the regional campus changes in any way?
- Given the different missions of the regional campuses and the growing difference in tuition levels between the Columbus campus and the regional campuses, what is the appropriate balance between consistency with Columbus campus financial guidelines and flexibility to address individual campus needs?

The Commission held 19 meetings over 12 months. A video-conference approach to full Commission meetings was adopted. It:

- reviewed the Academic Plan; the “working paper” prepared for the Commission’s use; the 1997 University Accreditation Report; the 1996 Regional Campus Functional Mission Statements; and other documents.
- organized its work through four Subcommittees. Each gathered and analyzed relevant information for its tasks and held separate meetings. The Subcommittees, and their membership, were:

Mission/Governance (**Karen Hendricks, Chair**, Thomas Brannon, John Hellmann, and John Riedl)

Admissions/Enrollment (**James Mager, Chair**, Terri Fisher, James Patterson, and W. Randy Smith)

Students/Student Services (**Diane Whitbeck, Chair**, Robert Gold, R. Vladimir Steffel, and Shellie Shirk)

Faculty/Curriculum (**Richard Petty, Chair**, Leslie Beyer-Hermesen, Graeme Boone, Matthew Stenzel, and W. Randy Smith)

- interviewed Vice Provosts for Regional Campuses at the Pennsylvania State University and the University of South Carolina.
- held site visits at each Regional Campus (November 1 and 8, 2001) with 4-6 Commission members present at each visit
- met with Dr. Garrison Walters, Vice Chancellor, Ohio Board of Regents
- through the Mission/Governance Subcommittee, met with the Presidents of three of the Co-located Technical Colleges (Central Ohio Technical College; Lima Technical College; North Central State College).
- met with the University Staff Advisory Committee.

- met, as a group, with the President of the Newark Campus, Dr. Anne Cairns Federlein, and the Regional Campus Deans/Directors, Dr. F. Dominic Dottavio – Marion; Dr. Violet O. Meek – Lima; and Dr. John O. Riedl – Mansfield.
- met, as a group, with the five Deans of the Colleges of the Arts and Sciences (Karen A. Bell, Dean, College of the Arts; Robert Gold, Dean, College of Mathematical and Physical Sciences; Richard W. Hall, Interim Dean, College of Biological Sciences; Michael J. Hogan, Dean, College of Humanities, and Executive Dean, Colleges of the Arts and Sciences; and Randall B. Ripley, Dean, College of Social and Behavioral Sciences); and with Professor Evelyn B. Freeman, Director, School of Teaching and Learning, College of Education

As the work of the Commission neared completion, an overview of the recommendations was presented by Vice President Moser and other members of the Commission:

- on each Regional Campus (Marion: May 20, 2002; Lima: May 21, 2002; Newark: May 28, 2002; and Mansfield: May 30, 2002).
- to the University President’s Planning Cabinet: June 5, 2002
- to the University Senate: June 5, 2002
- to The Ohio State University Board of Trustees: June 7, 2002

The remainder of this Report is presented in two major sections: an overview of the basic characteristics of the Regional Campuses today – the base on which planning must build; and the analyses and recommendations associated with the work of each of the Commission’s Subcommittees.

III: The Regional Campuses Today: An Overview

Development

The Ohio State University’s four Regional Campuses were established in the late 1950s. This was an era when there was a growing emphasis, nationally, on the value of higher education; when, in response, the state was creating an expanded set of opportunities for access to higher education throughout Ohio – at new public universities, and community and technical colleges; and when The Ohio State University itself was expecting to experience very dramatic enrollment growth.

Each Regional Campus has had its own unique features of early development, but throughout the decades, **all** have been characterized by two major features: they have provided **access** to higher education for students in their regions – notably direct access to the state’s land grant and a leading Research I University; and they have experienced

substantial and continuing support from their local communities. The first classes were offered in borrowed or rented community buildings, but by the 1960s permanent facilities were constructed at each location. The permanent campuses were made available not just through state funding, but also through the generosity of the local communities – the result of private fund-raising efforts and enormous support for the University.

In the 1970s, independently-administered technical colleges were permitted to co-locate on each of the Regional Campuses: Lima (James A. Rhodes State College); Mansfield (North Central State College); Marion (Marion Technical College); and Newark (Central Ohio Technical College). Throughout the 1980s and 1990s, these campuses experienced moderate but sustained growth in students, programs, and facilities, and now they are campuses ranging in size from 180-600 acres. Each has become a source of great local pride to the small city in which it is located.

An important, pervasive feature of the Regional Campuses is that their mission has been continuously evolving to respond to the changing needs of the communities they serve. At the outset, many local citizens believed that although the Regional Campuses began with a two-year mission (as entry points to higher education in the region), they would quickly develop strong four-year undergraduate programs as well. That did not occur as quickly or extensively as expected. However there has been programmatic expansion, first to include four-year degree programs in elementary education, and then during the past decade, to making available all the requirements for some liberal arts and other baccalaureate degrees and a small set of graduate programs. The current high levels of enthusiasm for the University in these communities can be related to the belief that recent mission evolution is fulfilling initial programmatic expectations.

Administration and Funding

Each Regional Campus is funded independently by the state, receiving its share of tuition and state subsidy. Each provides the Columbus campus with funding to offset costs of services that are provided through Columbus. Each campus has its own capital funding and is able to plan and finance capital projects. Each Regional Campus is co-located with a public two-year technical college with which it shares some facilities and has developed a cost-sharing agreement governing the administration of, and payment for, shared services.

Currently the Lima, Mansfield and Marion campuses each has a Dean/Director who serves in five-year terms, who interacts regularly with his/her administrative counterparts on the Columbus campus, and who reports directly to the University's Executive Vice President and Provost. In 1999, the Newark campus established a distinctive administrative structure, with the appointment of a campus President who administers both The Ohio State University Regional Campus and the co-located technical college. An Academic Dean position was established for the University's Regional Campus there. This Dean reports to both the Newark President and the University's Executive Vice President and Provost.

In 1994, The Ohio State University Board of Trustees appointed a Board of Trustees for each Regional Campus to replace the pre-existing Citizen Councils. Each campus now has an eleven-member Board.

Faculty and Staff

Combined these campuses have approximately 150 regular tenure track faculty. Each is a member of a tenure-initiating unit (TIU) - an academic department or school - based on the Columbus campus. The vast majority of the faculty (90%) is from a department or school in one of the 5 Colleges of the Arts and Sciences (Arts; Biological Sciences; Humanities; Mathematical and Physical sciences; Social and Behavioral Sciences). This group can then be subdivided into those who are part of a small (3-5) faculty cluster – as in English or Mathematics – and others who are the sole representative of their discipline on the campus (Music, Geography, Philosophy). The remaining 10% are from the College of Education. The hiring and tenure and promotion processes associated with these faculty are handled through interactions between the Regional Campus(es) and the TIU. Each campus employs approximately an additional 30 or more people, with varying titles, to help with the instructional mission. None holds regular tenure track faculty status.

The faculty teach small classes (24 students on average) and some honors sections are offered. The faculty have University-wide reputations as strong teachers and indeed a disproportionate number of them has received the prestigious Alumni Distinguished Teaching Award. Regular tenure track faculty engage in scholarship in their field, and are expected to be involved in outreach and engagement activities with their local communities. Each campus has some form of local faculty assembly, and each has one elected faculty representative to the University Senate.

Each campus has approximately 60-70 staff members to support the academic mission of the campus. The staff cover the full range of academic and academic support services, including, among others: admissions, advising, business services, computing operations, continuing education, community relations, financial aid, facilities maintenance, libraries, human resources, and marketing/public relations.

Students and Academic Programs

These campuses maintain an “open enrollment” policy for in-state students. Combined, currently they enroll approximately 6000 students, with enrollments ranging, by campus, from 1200-2000. Currently students are drawn heavily from the adjacent counties, but recent data reveal that there are growing numbers of students drawn from metropolitan areas from throughout Ohio, and indeed from other states as well. These campuses have approximately 5% minority populations, a smaller proportion than the Columbus campus but a more accurate reflection of the minority populations from the regions they serve.

Students can earn **Associate of Arts** degrees; get all the courses necessary to complete a **Baccalaureate** degree in English, Education, Psychology, History, and most recently

Business, and can complete the **Master of Arts in Education**, **Master of Education**, and much of the **Master of Social Work** degrees. These students are Ohio State University students and while enrolled, the same academic standards are applied to them as to students in Columbus. Those who complete degree programs on the Regional Campuses must adhere to all standards of an Ohio State University degree. Approximately 35% of Regional Campus undergraduate students move to the Columbus campus, and they must be fully prepared to compete with Columbus students.

The vast majority of these students commutes to the campuses. Mansfield and Newark have housing availability in off-campus, but adjacent, privately-owned and managed apartments. Each can house approximately 120-130 students. Lima and Marion currently do not have this option but recently have begun planning for it.

All Regional Campus students are students of The Ohio State University, and have access to University facilities and services, but each campus provides its own services as well such as advising. Student tuition and fees are approximately \$300-400 less per academic quarter than for Columbus students. The fee differential is partially offset through the state's "access challenge" funds that began in the late 1990s, administered through the Ohio Board of Regents. Financial aid for students is administered by the University's Office of Financial Aid on the same basis as for Columbus students. In addition, each campus has "endowed" and "current funds".

IV. The Future of the Regional Campuses: Issues and Recommendations

In response to its charge, and based on the framework suggested in The Ohio State University Regional Campuses: Future Development Issues (2001), the Commission organized its work, and this Final Report, around five broad topical areas: Mission and Governance; Admissions and Enrollment; Students and Student Services; Faculty and Curriculum; and Co-location with a Technical College. Each is now addressed in turn.

At the outset, however, it should be stressed that this Report does **not** address issues that are specific to a particular Regional Campus. Instead it addresses broad issues that affect all campuses. This approach may actually then help provide a context to address specific campus matters. Moreover, the Report does **not** try to address every broad issue that emerged as a result of the review process. Instead, it focuses on what it considers to be major issues most relevant to either the role of the Regional Campuses in the Academic Plan, and/or their place in the changing higher education landscape of the State, and then presents both immediate and longer-term recommendations for each. The University, through the Office of Academic Affairs, is about to begin (2002-03) a new round of Program Review. In the years ahead, it is likely that each Regional Campus will be reviewed and specific campus issues, or broad issues not analyzed here, can be addressed at that time.

It should also be noted that the charge to the Commission included reference to the Agricultural Technical Institute (ATI) in Wooster, Ohio. The Commission reviewed

information about ATI and concluded that because it has a distinctive programmatic niche within the state, and because administratively it is aligned with a specific college (Food, Agricultural, and Environmental Sciences) within the University, it should not be analyzed as if it were the same as a Regional Campus. It is not. However, it is a separate geographic location of The Ohio State University and is a part of the set of places that makes up the University, therefore reference to ATI is made in some sections of the Report, notably with regard to Admissions and Enrollment.

i) General Recommendations

Two over-arching recommendations are made.

First, Regional Campuses – their roles and characteristics – are not well understood by most members of the total University community. Most academic units in Columbus do not have faculty members at a Regional Campus; students who change from a Regional Campus to Columbus are not identifiable to faculty in any direct way; the number of Regional Campus staff members in any functional area is small and the degree of interaction with counterparts in Columbus varies. If the Regional Campuses are to be an integral part of the University's Academic Plan (2000) then the issue of specifying their importance and relevance needs to be addressed.

The Commission recommends that the University should routinely and regularly:

- **clarify and specify why the University has and needs Regional Campuses.**
 - i) They provide access to higher education in general, and to The Ohio State University specifically, for Ohio citizens who would otherwise be un-served. They represent an alternative to those who are place bound or whose preparation is not yet sufficient for enrollment on the Columbus campus. Indeed with smaller classes and faculty teaching, they create a more intimate (small college) learning environment for those who want and need it.
 - ii) They establish a formal geographical presence for the University outside Columbus, in the small cities and the multiple-county regions that each serves. These campuses broaden the University's political base.
 - iii) They enhance economic development in their regions of the state. That Universities are generators of economic development is well-documented, understood, and appreciated. The very existence of the Regional Campuses as places of employment in these cities, combined with the impacts of the research, teaching, and outreach of the faculty help the University contribute to local economic development.

- iv) They strengthen the learning and cultural opportunities within the local community, notably through their outreach and engagement activities. Whether it is offering presentations at/for students at local schools - along with pre-service and in-service opportunities for teachers; artistic presentations; workforce development programs; or non-credit courses/programs, the Regional Campuses provide opportunities for local residents to engage with the University. The result is that a strong allegiance – in terms of learning and cultural opportunities - between each campus and its community has developed.

More specific recommendations about this issue are offered in the sections on Mission and Governance, and Admissions and Enrollment.

Second, the Regional Campuses are an important part of the University, and indeed for several decades, but especially over the past ten years, we have adopted, in both personnel and curricular matters, the “**one University-many locations**” model. However, it is clear that within that one-University model, there is a high level of variability in the extent to which administrative functions and processes demonstrate formal and strong integration between the Regional Campuses (both individually and collectively) and Columbus.

The Commission recommends that the University:

- **establish, immediately, stronger internal (intra-University) “system” operations than currently exist in many administrative areas.**

Stated simply, the Regional Campuses are an integral part of the University, but now need to begin to function that way more fully in systemic terms. More specific recommendations about this issue are provided throughout this Report.

ii) Mission and Governance

Mission

Over time the University has increasingly linked, in formal ways, the “mission” of the Regional Campuses to the University’s mission overall. In 1987, when the University was re-accredited by the North Central Association of Colleges and Schools (NCA), for the first time the Regional Campuses were not reviewed and re-accredited separately. They were part of a full University review. That practice continued in the 1997 re-accreditation. In 1996, the Ohio Board of Regents sought, received, and approved, a separate Functional Mission Statement for the University’s Regional Campuses, but the document made it clear that these campuses were a part of the University, playing selected special roles – notably access.

However, the Academic Plan (2000) does not make specific reference to the Regional Campuses. They are included indirectly as they relate to enrollment planning at Columbus, in that they will remain “open admissions” as the Columbus campus becomes more selective. This could have an impact on the number of students applying to Regional Campuses, their level of preparedness, and their geographic origins. More broadly, given that faculty are linked formally to a Columbus campus tenure initiating unit (TIU), and they offer a University curriculum to students who are University students, then the Regional Campuses have a direct link to virtually all parts of the Academic Plan.

Given these considerations, the Commission affirms that **the Regional Campuses are a part of The Ohio State University and, as such, share the vision, purpose, core values, and future goals of the University’s strategic plan.**

The Commission recommends that the University:

- **revise the University’s “vision” statement, within the Academic Plan, to:**
 - **alter the statement to note “on each of our campuses” or “on all campuses” where appropriate**
 - **indicate formally that the Regional Campuses will expand the reach of the University’s missions and serve as valuable resources to each region in Ohio, and will offer courses and a select number of degree programs from the University curriculum.**
 - **indicate formally that they will provide entry for students who may not otherwise have access to the University, and will prepare them to successfully complete degrees**

A “draft” suggested revised Vision Statement to address these points is attached as Appendix I.

Governance

Although the Regional Campuses are often viewed as a “collective” and at times function that way, the fact is that they have evolved independently since their establishment four decades ago. Differences in local influence, leadership at the campus of both Ohio State and the co-located technical college, legislative support for the region, and the level of involvement from Columbus campus administration, have all resulted in the unique history, varied values, and distinct struggles that make each campus what it is today. In some cases, personalities and conflicts have shaped governance practices and

administrative structure. In other cases, Board leadership with strong local influence, or Columbus influence, has molded the structure and direction of the campus.

Today governance differences exist across the campuses. They shape the values and priorities of these institutions influencing everything from leadership selection, the extent of collaboration with co-located technical colleges, financial management, scholarly emphasis, marketing, student perception, and the relationship with Columbus administration and faculty.

The governance model at OSU-Newark is particularly distinctive and deserves comment. Unlike Lima, Mansfield, and Marion, where there is a Dean/Director for the University campus, the President of the Newark Campus has oversight for both the co-located technical college - Central Ohio Technical College (COTC) – and the Ohio State Regional Campus. She is responsible to two independent Boards of Trustees. Her performance is assessed by the COTC Board and she is paid by COTC (with a portion of that expense allocated to Ohio State). In addition the Newark Campus has established the distinctive position of Academic Dean, someone who reports to both the Newark campus President and the University's Executive Vice President and Provost. This issue of variation in governance is addressed more fully in the section of this Report on Co-Location.

Each Regional Campus has a Board of Trustees composed of nine citizens from the region, one student member, and one member from the University Board of Trustees. These Boards, in effect, are accountable to The Ohio State University Board of Trustees that has ultimate responsibility for the Regional Campuses. This should not, however, be construed to diminish the importance of the day-to-day governance role the Regional Campus Boards assume. They are the experts on local governance and oversee the details in Regional Campus budget setting, capital expenditures, and they anticipate and address unmet needs in the local region.

All campuses operate from a common set of by-laws for Regional Campus Boards of Trustees. However the Commission believes that more specificity is needed regarding regional board authority/delegation. Indeed the University is completing its first set of three 3-year cycles of Regional Campus Trustee appointments and it is an appropriate time to review the process.

The Commission recommends that the University:

- **revise the By-laws of the Regional Campus Boards of Trustees to introduce a more structured nomination and selection process; better educate and communicate directly and more consistently with local board members; and to seek financial synergies across Regional Campuses rather than only with co-located technical colleges.**

Specifically:

- i) provide annual local board member orientation and education sessions (1 ½ or 2 day) through the Board of Trustees Office**
- ii) provide ongoing written communication to local board members about Ohio State.**
- iii) standardize the nomination process and define the selection criteria with final agreement through the University Board.**
- iv) Define committees, committee purpose, and officer selection process for consistency and quality across campuses.**
- v) make specific the role and responsibilities of the Regional Campus trustees.**
- vi) look for synergies across Regional Campuses – for example in marketing and course sharing.**
- vii) improve student services on Regional Campuses, including increased advice from and connection to the Columbus campus.**
- viii) establish an ongoing committee of the University Board composed of the Board representative for each regional campus.**

A “draft” proposed set of by-laws is provided as Appendix II and might be helpful to the further discussion of this issue.

Functioning in Systemic Terms

If we are to operate as one University, then attention needs to be given to the functional relationships between the Columbus campus and the four Regional Campuses. The extent to which there are true “systemic” operations varies.

In faculty hiring, and promotion and tenure procedures, the concept of a “system” generally works well. Formal processes and routine interaction between the TIU in Columbus and the faculty members and the Dean/Director and/or President at the Regional Campus have been established. For many other areas, improvement in systemic functioning is needed.

Included are:

- the inter-related areas associated with undergraduate services (admissions/advising/financial aid). Issues related to communication between Columbus and the Regional Campuses, and centralized versus decentralized decision-making exist and need to be addressed.
- student affairs. With the growing emphasis on Regional Campus housing and the need for additional activities for all students, an increased pattern of interaction with the Office of Student Affairs in Columbus needs to begin. This Office has substantial, successful experience with such matters and can be of help to these campuses.

- business and legal affairs. The growth of these campuses themselves and the changing landscape for higher education overall, have meant that each is involved in a growing set of space and facilities planning activities. Each has a draft Master Plan. As they plan for new buildings/facilities on site, seek expansion to off-site facilities/locations, or develop new working relationships with the co-located technical college, a complex set of business and legal matters emerges. University procedures/processes need to be followed. The relevant administrative offices in Columbus need to be involved.

If the concept of systemic functioning is to occur, then these types of activities should not be carried out in piecemeal fashion. There needs to be some level of central coordination. Today no one person in Columbus has overall coordination responsibilities. Instead, several Vice Provosts in the Office of Academic Affairs have specific functional (personnel, curriculum) responsibilities for these campuses. Indeed, in that regard, the level of attention that Regional Campuses get is actually higher than it has been in more than a decade. However, at times, this approach can delay responses/actions in routine matters if they do not align directly with one of the Vice Provost's functional areas.

The Commission recommends that:

- **the Executive Vice President and Provost should review the current pattern of interactions between the Vice Provosts and the Regional Campuses and determine how, administratively, coordination will be improved. The result should in no way interfere with the current pattern of the dean/director having direct access to the Provost when needed.**

iii) Admissions/Enrollment

As the Academic Plan is implemented and the Regional Campuses maintain open admissions, it is likely that these campuses will experience modest enrollment growth, and will begin to attract more students from throughout Ohio and beyond. If the goal is to enhance system-wide functioning, then six major issues with regard to admissions and enrollment need to be addressed. Each has been a topic of considerable discussion in recent years and needs immediate attention.

Application

The current application process to The Ohio State University does not give students a set of choices from which to select. This has led to the awkward situation where some students receive a letter indicating that they cannot be admitted to the Columbus campus, but emphasizes enrollment at a Regional Campus as the best option.

The Commission recommends that the University:

- **Revise the application for admission: ask students to indicate both a first-choice and an alternate choice-campus**

Beginning with the incoming class in 2003, students applying for undergraduate admission will have the option of indicating an alternate choice campus in addition to first choice. Appropriate messages will be developed and incorporated in application materials, other recruitment publications and brochures, web pages, and recruitment presentations to accurately depict the residential and student life scenarios on each campus. Print materials alone could not provide sufficient detail, and must provide references to detailed web content.

Note: “Alternate choice” is the wording used on The Pennsylvania State University application materials and has greater appeal than “second choice.” (see: <http://www.psu.edu/dept/admissions/apply/AppForm.pdf> The “campus choice” information is on page 5 of 8.)

- **Revise the options letter to Ohio residents denied admission to the Columbus campus**

Upon adopting the process described in the above recommendation, Ohio residents not admissible to the Columbus campus who have indicated an alternate-choice campus will get a letter emphasizing their admission to their alternate choice campus, rather than their inadmissibility to Columbus. Students not admitted to Columbus who do not indicate an alternate campus will receive a letter similar to the current denial/options letter, one that emphasizes enrollment at a Regional Campus as the best option. The wording for this letter will be composed by Undergraduate Admissions in Columbus and approved by Regional Campus colleagues.

Campus Change

Current “campus change” policy indicates that students are eligible to change from a Regional Campus/ATI upon earning 30 quarter hours with a 2.0 GPA. Students may change to the Columbus campus in the Spring regardless of hours completed or GPA. Students denied admission for Autumn Quarter, Columbus campus and offered Winter (on the Columbus campus) may change to Columbus in the Winter Quarter. Regional Campus students who meet the freshman Columbus campus admission criteria for Autumn Quarter may change campuses at any time.

The admission criteria for transferring from other institutions are more stringent. Students are eligible to transfer to Ohio State upon earning 45 quarter hours with a 2.0. The Spring and Winter quarter options described above do not apply to extra-university transfers.

Transfer students who meet the freshman Columbus campus admission criteria for Autumn Quarter may transfer at any time.

Research data indicate that students who are not admissible to the Columbus campus, and who earn 45 hours or more on a regional campus are more likely to graduate than are students who change to the Columbus campus earlier.

The Commission recommends that:

- **With the exception of students whose high school credentials qualify them for admission to the Columbus campus, students beginning on a Regional Campus/ATI must complete a full year (45 quarter hours) before changing to the Columbus campus.**

This will ensure the best possible preparation for campus changers. This recommendation is made with the understanding that many students currently perceive the present campus change policy to be a benefit of Regional Campus enrollment. However, enrollment data proves that the educational benefits of spending a full year on a regional campus far outweigh the seeming convenience of a premature campus change.

Future Admissions Policies

The Regional Campuses have open admission policies for Ohio applicants and competitive admission policies for non-residents. Non-residents applying to Regional Campuses are considered under less selective admissions standards than are non-residents applying to the Columbus campus. If, as expected, enrollments grow at these campuses, then we need to be prepared to adjust our admission policies accordingly.

The Commission recommends that the University:

- **establish principles for future admissions policies: If a Regional Campus cannot accommodate demands for academic resources, then the following priorities should guide admission policies for each regional campus.**
 - i) **Open admission for Ohio residents.**
 - ii) **If a Regional Campus reaches enrollment capacity, then increased selective admissions criteria should be used for non-residents, and all interested Ohio residents should be admitted using open admissions criteria.**

Advising

Once enrolled at a Regional Campus, students have a variety of options for courses and programs and need to work with advisers for both short-term and long-term programmatic planning. Information gathered from academic advisors at the four Regional Campuses reveals that there are very distinct groups of students.

- Students who were denied admission to the Columbus campus and want to get there as soon as possible, and students who for family or financial reasons needed to start at the Regional Campus but do not want to stay any longer than they need to do.
- Students who plan to stay for at least two years or even longer, but need to go to Columbus eventually.
- Students who intend to stay as long as it takes to complete a degree.
- Students who were originally in one of the first two categories and then decided to stay at the Regional Campus longer.
- Students who have transferred from other campuses or who originally started at the Regional Campus and have returned after attending a larger campus for a while.

Each of these groups of students has somewhat different advising needs. Most students usually make the decision on their own whether and when to switch to the Columbus campus. They typically use the academic advisors to facilitate the change, not to help with the decision. An exception to this seems to be the students who are undecided as to their major. They seem often to be undecided as to what campus to attend as well.

The advisors seem to have consistent ways of advising students as a function of the student's major, academic ability, and circumstances. The advisors seem to always put student's educational goals and personal situation at the forefront. For certain majors, students are urged to change to the Columbus campus as soon as possible. This is because some majors require sequenced courses that are not offered at the Regional Campuses and are in the student's best interest to take early in the major. For other majors, there is no such urgency. Many of the advisors indicated that they encourage stronger students to change to Columbus sooner than weaker students who might benefit more from the Regional Campus environment.

Some advisors indicate to students that when an identical course is offered in Columbus and at the Regional Campus, the Regional Campus is usually the better choice due to class size, access to faculty, and more convenient services. When proceeding through a sequence, particularly in the major, a break of even one quarter is to be avoided if at all possible. If the student has failed or missed a course in a once-a-year sequence at the Regional Campus, the student is advised to continue the sequence in Columbus. Some particularly strong students are sometimes advised to go to Columbus even if they could get their degree at a Regional Campus. Some students are advised to pursue their education at the co-located technical college.

Regional Campuses offer substantial support to students who wish to change campuses. A procedural checklist is provided to students. Representatives from the various

University colleges attend a Fair on the Regional Campuses. There is a campus change day at the Regional Campuses for students who intend to make the switch. Students are sent to Columbus for a campus tour and for orientation.

The academic advisors appear to have no vested interest as to which campus the students attend. There does not seem to be pressure placed on students to remain at the regional campuses, regardless of their intended major.

The Commission recommends that:

- **Advising should continue to be University-focused. The advising system at present seems to be functioning well. Efforts should be made to ensure that the advising on which campus to attend continues to put the needs of the student before the needs of the particular campus.**

There is, however, for students who change to Columbus, no follow-up after they arrive at the Columbus campus. A more detailed analysis of issues (both academic and academic support) relating to the transition would be helpful, notably to share with students who will be changing campuses.

The Commission recommends that:

- **efforts should be made to follow-up, in a more systematic way, with students who have moved to Columbus, to gather information on the adjustment process. That information should then be used to help future students with the transition.**

Marketing and Recruiting

There is not a fully developed, consistent message in marketing/recruiting efforts relating to the Regional Campuses: their nature, their role as part of the University. This issue needs to be addressed immediately. Each Regional Campus offers distinct advantages, including: (1) a student-friendly environment rich with opportunities for dialogue and relationship-building between students, faculty, and staff; (2) tremendous access in the form of evening and weekend opportunities, child-care resources, lower costs; (3) a close-knit environment in which students, faculty, and staff are truly invested in their community; (4) a rich diversity of ages and experiences. Messages and recruiters must not draw negative comparisons between campuses when describing the positives of any campus, but should instead promote the strengths of all campuses.

The Commission recommends that the University:

- **develop recruitment messages relating to the special nature of the Regional Campuses. Undergraduate Admissions and First Year Experience should use these messages in collaboration with University Marketing Communications**

as a guide in producing promotional communications about the university and its Regional Campuses.

Marketing messages will evolve as academic, residential, and co-curricular opportunities on Regional Campuses and satellite locations develop. Specifically, beginning with the recruitment of the incoming Class of 2003

- A description of all the university's campuses should become standard in all comprehensive recruitment presentations.
- Publications and other marketing communications should refer to "all campuses" when describing features or opportunities common to all campuses.
- References to university opportunities for working nontraditional students should increasingly cite Regional Campus opportunities.

There are three contexts for delivering Regional Campus messages:

1. when discussing the university overall.
2. when discussing the Regional Campuses and ATI as a group
3. when discussing specific features of individual campuses.

The University needs to develop, immediately, appropriate messages for the first two contexts. Development of messages for the third context would appropriately occur on each campus. The University-wide messages should be among a set of 10-12 marketing messages composed to guide all recruitment communications pieces and presentations. Ideally, as the Regional Campuses continue to develop, there will be fewer distinct messages about the Columbus campus and the Regional Campuses, and more messages about **Ohio State as one University with many locations.**

The Pennsylvania State University's web page could serve as a good model for The Ohio State University. It features a "getting to know your campus" link that provides a possible future direction for the general promotion of Ohio State's campuses — the page treats all campuses equally and provides a graphical "jumping-off" place from which browsers can visit each campus web site. (See: <http://www.psu.edu/dept/admissions/campuses/index.htm>.)

Enrollment Projections

In 1994, the Columbus campus submitted a Functional Mission statement to the Ohio Board of Regents. An important element of it was the goal to improve its undergraduate student academic profile. At that time, the University's retention rates and graduation rates were the lowest among Council on Institutional Cooperation (CIC) – Big 10 plus the University of Chicago - institutions. The mission statement proposed developing and pursuing a plan that would place Ohio State's student profile in the upper half among CIC institutions. After this mission statement was approved, a seven-year plan was

developed to meet these goals.

As Columbus campus admission criteria were increased, more students were referred to the Regional Campuses and to ATI. By 2000-2001, more than 540 students who applied but were not admitted to the Columbus campus chose to begin their Ohio State education at one of these campuses.

As we come to the end of the seven-year plan, there will be considerably less growth in the number of applicants not admitted to the Columbus campus compared to the growth experienced in the last six years.

Although we expect little growth in the numbers of applicants not admitted to the Columbus campus, we can expect continued growth in enrollment at the Regional Campus among such applicants for the following reasons:

- a. Improved marketing recruitment messages about regional campus opportunities (see above)
- b. Improved application/admissions procedures (see above)
- c. Development of residential and student life opportunities (recommended below)
- d. Increased number of four-year degree programs at regional campuses (recommended below)
- e. Increased number of distance learning opportunities (recommended below)

The Commission recommends that:

- **As these five growth opportunities evolve simultaneously, a sophisticated Regional Campus enrollment projection process must be developed and implemented as soon as possible. That process should involve the following market analyses for each of the regions of the State of Ohio:**
 - i) **Projections for demand from all regions of Ohio if Regional Campuses have increased residential and student life opportunities**
 - ii) **Projections for demand from all regions of Ohio for new four-year degree programs**
 - iii) **Projections for demand for satellite operations and distance education opportunities**
 - iv) **Projections of increased enrollment from applicants not admitted to the Columbus campus. Given that there will be little growth in the cohort, the analysis should attempt to provide projections for increased enrollment yield based on:**
 - **increased academic opportunities**
 - **increased residential and student life opportunities**

- **improved ease of application/admission processes**
- **increased public awareness of these benefits and opportunities**

This market analysis process should begin immediately, and should be a prerequisite to any large-scale expansion of academic programs, student life programs, and academic and student life building projects.

iv) Students and Student Services

Issues relating to students and student services were identified through visits to Regional Campuses, meetings with Regional Campus deans, and a written survey of the Deans or their student services director. The Commission focused on two major topical areas: the development of student housing, and the development of student services – broadly defined.

Student Housing

No “service” issue receives more attention today on the Regional Campuses, than the need for student housing. This is an important issue if these campuses are to have the role in admissions to the University that emerges from the Academic Plan. Student housing is unquestionably a top priority for each Regional Campus Dean. Two campuses - Mansfield and Newark - have adjacent apartment complexes originally built and managed by a private developer who also purchased the land. Lima and Marion have no housing options at this time.

In 2001, the budget bill was passed by the legislature omitting a long-standing clause that prohibited the construction of new student housing by state-funded colleges and universities. The University then had the opportunity to pursue University-owned and constructed student housing on its Regional Campuses. In November and December 2001 the University Board of Trustees gave approval for each Regional Campus to begin a planning process for student housing. The Lima, Marion, and Newark campuses have partnered with the Office of Student Affairs in Columbus to obtain final approval from the Board of Trustees for construction of their respective student housing projects - after architects have finished the design - and business plans have been established. Currently each campus is involved in that process, although each is at a different stage (negotiations, constructing pro-forma, selecting architects).

As the University moves forward, there are three models that can be used to plan, construct and manage student housing on regional campuses.

i) University Owned and Managed Student Housing Services

In this model the Office of Student Affairs in Columbus would use University land and plan, build, and construct a student-housing complex in partnership with Regional

Campuses. There are many benefits to this model. Given that University student development staff is involved in planning, student housing can be designed with student needs in mind. Profit is not always the “decision-maker”. Thus, the student-housing complex can include non-revenue generating space that University staff feels will enhance the student experience. Such space would include computer laboratories, study lounges, exercise rooms, community lounges and programming space. Parents tend to feel more comfortable with their students living in University owned facilities, and the students feel more strongly linked to the University because of the seamless interaction between University student housing staff and other University departments. In addition, a major priority of University-managed student housing is the establishment of environments and experiences to augment classroom experiences. Living/learning centers, a wide variety of educational, social and recreational programs, leadership development, and teaching students to be responsible citizens of a community, are a few of the opportunities University housing staff provide students.

On the other hand University-owned and managed student-housing means that the University is assuming all financial risk of the project. University construction projects must adhere to a multi-phase process with many approvals along the way. Thus, University projects take much longer to finish. Furthermore, the University has very high building standards and state laws and procedures to follow. This makes University construction projects more expensive than those done by a private developer. Aside from a proper and accurate business plan for each regional campus student housing project, the amount of financial risk for the University will be largely determined by the growth of each Regional Campus and the success of each in reaching enrollment goals

It should also be noted that research, both on the Columbus campus and nationally, indicates that students who live in University housing are more likely to persist in college, obtain better grades and graduate. Without doubt, University student housing with community spaces and programs such as all of those mentioned above is very desirable for student success.

ii) Private Developer Constructs and Manages Student Housing Services

In this model a private developer usually buys land adjacent to the campus and then plans, constructs and manages housing for University students. The major benefit in this model is that the University assumes no financial risk. The developer has only state codes with which to comply so the cost of the housing complex can be less by using lower construction standards than those in place at the University. Also, since the project is privately owned, the developer does not have to seek all of the reviews and approvals which a University project would need. Thus, privately developed student housing can cost less and be completed more quickly than a University project. For Regional Campuses that consider student housing to be a top priority, this model can be very attractive.

The success of this model depends almost entirely on the quality of the developer and his/her relationship with the Regional Campus. In the case of Mansfield both the

developer and his relationship with the campus seem to be very strong and supportive. However, these characteristics are largely subjective and certainly without guarantee. While the University assumes no risk in this model, it also has very little control of how the student-housing complex is constructed or managed. The developer is usually interested in profit, so quality construction, non-revenue generating space, and quality of student life may be secondary considerations. In this model we are, in essence, encouraging students to live off campus (but with the housing being very close to campus). However, just as with off campus housing, this housing development is not tied to the academic goals, the quality of student life, or more broadly, the values of the University.

iii) Private Developer Builds and University Manages

This could certainly be seen to be the “compromise” model where the private developer can assume all of the financial risk, can construct student housing quickly, while students have the advantages of University student affairs professionals managing the student complex. While this seems to be ideal, its success is really dependent on the contract between the University and the developer. Can the University specify the quality of construction, the inclusion of non-revenue generating community space, and a long-term an exclusive management agreement? Would a private developer be willing to enter into a long-term contract and bear all of the financial risk, while the University then assumes all, or a great deal, of control? It is unlikely.

Another possibility is the “Design/Build” model where a private developer is hired to build a student housing complex on University-owned land and then the University buys the housing complex at the end of construction. This was the model used to build the ATI student apartment complex. This model can be attractive because the University hires the developer, is very involved in planning the student housing complex, and the process can save time and funding. However, since the project is built on University land, prevailing wages must be paid and the project must obtain certain University reviews and approvals, so the project is neither as fast nor as low in cost as in the Developer Owned and Managed model. Furthermore, all of the advantages and disadvantages of University-owned and managed student-housing come into play as soon as the University buys the completed housing project from the developer.

Given these considerations, the Commission recommends that:

- **the University should adopt the University-owned and managed approach to student housing on the Regional campuses. This approach may take longer and the costs will be higher, but the University has experience in such activity and is attuned to the importance of establishing appropriate academic housing needs.**

While financial risk is certainly involved, an astute business plan along with attainment of enrollment goals would lower that risk.

Student Services

Students on all Regional Campuses would like to see more student programs and activities, and more funding for them. Currently there is little funding on Regional Campuses to enhance or expand student services, and no student activity fees are charged on any Regional Campus. The faculty and staff are concerned that they currently do not have the number of staff and space to house enhanced student services. The situation is complicated further because all Regional Campuses have “shared services agreements” with co-located technical colleges for facilities and/or some student services, and because student services need to be flexible given the somewhat different “mix” of students. Non-traditional students should not be overlooked. Moreover, all Regional Campuses would like to see more communication – notably through electronic mail - with the Columbus campus regarding upcoming events on the Columbus campus and how they have access to them.

Other issues that emerged on one or more campuses included the need for: extended hours for the library, computer laboratories, and athletic facilities; regular transportation between the Regional Campuses and Columbus for students to attend classes, activities, and events; the need to determine whether there should be more “intentional student” development experiences on the regional campuses; more support for minority students and for diversity programming; and enhanced training for student service staff.

Overall many Regional Campus students often feel like an “after-thought” with regard to services and do not believe that they are getting as full an Ohio State University experience as they might.

The Commission is unanimous in its view that additional and enhanced student services are needed on each Regional Campus. Three approaches to this issue are possible.

i) Regional Campus Autonomy Model

This model is very close to the current status of student services on each Regional Campus. Each determines the level of student services needed and affordable, and consults with the Office of Student Affairs in Columbus when necessary. That Office has had no expectations or mission to assist or consult with Regional Campuses, and so communication is sporadic and expertise gained from among the University’s campuses is not well utilized. This model does not address many of the issues surrounding student services on Regional Campuses, and shows no promise of enhancing student services now available, or establishing a cohesive student services action plan for Regional Campuses.

ii) The Columbus Model

In this model, the Office of Student Affairs in Columbus, with its long, successful experience in such activities, would direct the student services program on each Regional

Campus. This model is based on the organization of student housing at ATI that has worked well in the past. The staff would be hired by and report to the Office of Student Affairs in Columbus with the understanding that Regional Campus student affairs staff would work closely with the Regional Campus Deans or President. The success of this model is dependent on the willingness of the student affairs staff on the Regional Campuses to participate in Regional Campus life. Equally important is the willingness of the Regional Campuses to collaborate with a program and staff they do not supervise.

This model allows the Regional Campus Deans and President to concentrate on other important issues without the added burden of direct responsibility for enhancing and/or beginning new student service initiatives. However, without close collaboration, the knowledge and resources of the community could be diminished. The ATI housing model has worked well but its success has been dependent on collaboration.

iii) Collaboration Model

In this model, the Office of Student Affairs in Columbus would work very closely with each Regional Campus in many ways to consult, advise and recommend strategies to establish and/or enhance student services. In this model Regional Campuses would work with the Office of Student Affairs in Columbus to prioritize student service needs, participate in training, assess the efficacy of Columbus programs on Regional Campuses and determine new programs and ideas. The Office of Student Affairs in Columbus would give advice on the student service organizational structure for each Regional Campus, consult on programming initiatives, take responsibility for timely and regular meetings, training, and communications, and consult on needs assessments, answer student needs, and resolve crises. Student affairs staff on each Regional Campus would be funded by and report to the Dean or President of the Regional Campuses, however, the Office of Student Affairs would assist in the recruitment and selection of staff using professional associations and networks.

This model provides the expertise of the Office of Student Affairs and takes advantage, where possible, of economies of scale. It also allows each Regional Campus to use its knowledge and resources in the community to set program and service goals and initiatives.

The Commission recommends that:

- **the University should adopt the Collaboration Model for student services on the Regional Campuses and an Action Plan that addresses funding, space and facilities, and implications of co-location, be drafted as soon as possible.**

v) Faculty and Curriculum

There is no more important element of the Regional Campuses – and their future - than their faculty. They are the center of the academic enterprise. They conduct the research, teach the courses and programs for the students, and provide service to the University and outreach and engagement activities to the community. On each Regional Campus the faculty are fortunate to be complemented by a very strong academic support staff.

To address issues relating to faculty and curriculum, the Commission reviewed procedures at other institutions, nationally, and considered information provided at open forums with the faculty, students, and staff.

Given the roles that we want the Regional Campuses to play, through the Academic Plan, and the fact that Regional Campuses emphasize primarily, but not exclusively, access to, and in some cases completion of, undergraduate baccalaureate programs, then in the years ahead what direction should we take, and what are the implications for faculty and curriculum? Is there a “model” for the University’s Regional Campuses to adopt and follow? These are topics that have not been discussed thoroughly, by the University, in recent years. The Commission gave them considerable attention.

Three Possible Models

Three types of relationships between a central campus and Regional Campuses with respect to faculty and curriculum are possible. One approach is the one university model. It assumes that there is just one University degree in any given program area (English, Psychology) that is designed to be the *same* on all campuses that offer that degree. In this model, the appropriate University departments/schools hire, promote, and tenure Regional Campus faculty and determine the curriculum. This is the model currently evident at The Ohio State University. Nationally, this appears to be a model unique to this University.

A second model is to allow each campus to hire, promote and tenure its own faculty and determine its own curriculum. This is the one system model. In this model, each campus offers its own degrees (a degree in English from OSU-Lima, for example). It has been adopted by virtually every other major state university system (the systems of the Universities of Wisconsin, Michigan, and Missouri, for example).

A third “hybrid” model, perhaps most well developed at The Pennsylvania State University, attempts to bridge the one university and the one system models. In this model, most of the Regional Campuses are grouped into a “Commonwealth College” which is separate from other colleges (Humanities, Social Sciences) on the central campus. In this model, the Commonwealth College is responsible for hiring, promoting, and tenuring faculty in its college (regional campus faculty). All students get a degree from the same university (untagged by campus), but a degree in English completed solely on a regional campus is granted by Commonwealth College, whereas a degree in English completed on the central campus is granted by the College of Humanities.

How do we determine which of these (or other) models is most appropriate?

The Quality of the Degree Programs

The Commission used as its starting point the underlying importance of the quality of the Ohio State University degree programs that we offer. The Regional Campus Deans agreed that their campuses should offer the “same quality of education” as in Columbus. Indeed, promotional materials for the Regional Campuses foster the perception that they offer the *same* degrees and educational opportunities as the Columbus campus. Can a “world class” or “Ohio State University quality” degree or educational experience be obtained solely at a Regional Campus? The promotional materials for these campuses suggest that they can. They suggest that the difference between campuses is mostly (or solely) one of “location.”

However, to address this question more thoroughly, it is important to know the criteria or standards for defining a degree of “Ohio State University quality” – something that differentiates it, as a University, from other institutions. If such criteria and standards were identified, it could be determined whether existing programs or newly proposed majors to be offered solely on the Regional Campuses meet this standard. There is a range of possible meanings for a University quality degree or experience that set it apart from other college and university degrees and experiences that are available for prospective undergraduate students.

At a minimum, obtaining a quality University degree might simply mean that students at each of the campuses have taken sufficient course work to fulfill a common set of General Education Requirements specified by the appropriate University authorities, and they have the opportunity to meet the minimum major course requirements specified by an academic department or school. According to this minimal definition, the Regional Campuses would offer a quality degree if they simply offered courses and degree programs from the University curriculum. This standard sets Ohio State apart from the other educational institutions in Ohio mostly by its defined curricular offerings rather than its status as a major research university with nationally recognized faculty. This definition is likely already to be met on our Regional Campuses in those current programs that lead to completion of a bachelor’s degree at those campuses.

A more rigorous definition might be that obtaining an Ohio State quality degree or undergraduate experience might mean that students have attended and experienced a major (“world class”) research university with exposure – especially in their major programs - to some professors who are nationally ranked experts in their fields; that undergraduates have the opportunity to join in cutting edge research opportunities in state-of-the-art laboratories; that students can expect a breadth of curricular opportunities and a depth of specialized courses in their major field of study; that students will interact with a selective group of diverse classmates from all over the country and world, and have an opportunity to partake in a rich array of cultural opportunities. It is likely that today the Regional Campuses do not meet this definition. In some

selective degree programs on the Regional Campuses, some of the standards specified here could be met (students would have the opportunity to participate in cutting edge research), but that no Regional Campus can currently meet *all* of the criteria in this definition solely within the confines of that campus – for example, offering a depth of course possibilities in the major area.

If the first definition were to be adopted as the standard for an Ohio State degree, or some other standard that all campuses could meet, it would be appropriate to think of and govern Ohio State University as one university with different locations across the state. On the other hand, if some standard that all campuses could not meet were adopted, an alternative structure might be preferable. For example, one could view and govern the several campuses as constituting semi-autonomous units that are organized into one system. The one university model implies that there should be one University degree with one standard of excellence, one faculty of comparable quality across the campuses, undergraduate majors with equivalent curricular opportunities, and so on. The one system model is more amenable to different campuses having different degrees with different standards, faculties, curricular opportunities, and so forth.

What the precise criteria or standards should be for calling a degree an “Ohio State quality” degree are **not** specified in this Report. The Commission notes only that if students on Regional Campuses are to obtain the *same* degree as students in Columbus, it is important to be explicit about such criteria and to be clear what it means to obtain an Ohio State quality education or quality undergraduate experience, versus one at another public or private university or college.

Although this Commission takes no stand on how to define a quality education or degree, it believes that if there is to be just one University degree (as is currently the case), the standards and criteria should be the same (or reasonably close) for all of the campuses that offer the degree. Conversely, if the criteria and standards are not the same across the campuses, then the degrees should be differentiated in some way. And, as implied by the two definitions above, the Commission believes that offering an “Ohio State quality” education should mean more than simply offering a common curriculum.

These considerations have implications for faculty and curriculum.

Faculty

The current procedures for hiring, promoting, and tenuring a faculty member on each campus are comparable. **With respect to procedure, the campuses do basically operate as “one university”**. The relevant campus first identifies the need for a particular faculty member. On the Regional Campuses, the person identifying such a need is typically the Regional Campus Dean. In Columbus, it is the Department Chair or School Director. Once a need is identified and the funding is approved (by the Regional Campus Dean or the College Dean in Columbus), the department chair appoints a search committee. The particular requirements for serving on this committee (for example, the proportion of regional and main campus faculty) are set by the relevant department’s

Appointments, Promotion, and Tenure (AP&T) document. In a typical case, the search committee consists of faculty from the appointing Regional Campus and the main campus. Following a national search, the search committee makes a recommendation or a series of recommendations to the relevant department faculty. The full department faculty then takes a vote as a recommendation to the department chair. The department chair then approves (or not) the hire as does the College Dean and Regional Campus Dean.

With respect to promotion and tenure, the current procedure is the same whether the faculty member resides on the Columbus campus or one of the Regional Campuses. In each case, the particular department's AP&T document specifies the particular steps to be followed. Typically, the candidate submits a dossier outlining accomplishments in the area of teaching, research and service. These materials, along with an assessment by the Regional Campus Dean, are evaluated by the tenured faculty in the department who prepare a report favoring or disfavoring promotion and/or tenure. The department chair prepares a separate assessment which is forwarded to the Dean of the appropriate College. The Dean makes another assessment and all of the materials and assessments are then forwarded to the Office of Academic Affairs for final dispensation.

Although the *procedures* for hiring, tenuring, and promoting faculty on each campus are basically the same, the standards and criteria used in making hiring, tenure, and promotion decisions are not necessarily the same for main and Regional Campus faculty. Rather, there appears to be considerable disparity across different academic departments. That is, in some departments, the standards and criteria for hiring, tenuring, and promoting Regional Campus faculty, if not identical to those in Columbus, would likely fall within a "range of comparability." At the other end of the spectrum, in some departments there is virtually no overlap in candidates for hiring, promotion, or tenure at the main and the Regional Campuses.

To understand better the complexities of this matter, the Commission examined in detail one large department that offers degrees on each campus and examined its hiring pattern over the past four years. Because this is just one department, it is not clear whether the results of this case study represent the norm or are an aberration, but the results are instructive. Among the findings from this case study are that:

- there was virtually no overlap in the candidates who applied for a position on the Columbus and Regional Campuses – even when the substantive areas searched for were identical in the same year. That is, the Columbus and Regional Campus searches competed in completely different job markets.
- the success rate in hiring varied across campuses. On the Columbus campus, at the untenured level, there were 4 offers and 4 acceptances. On the Regional Campuses, there were typically 3 or more offers for every acceptance. In the most recent year for which data were available (Academic Year 2001-2002), there were 11 offers made for four positions on the Regional Campuses with 3 acceptances.

- Starting salary offers varied considerably across campuses. For example, starting salaries were over \$10,000 higher in Columbus than on the Regional Campuses. Indeed, a recent report in the Chronicle of Higher Education (April 19, 2002) indicated that this was common in all universities with a flagship and Regional Campuses. A proportional gap exists at every professorial rank. In addition, there was a gap of about \$50,000 in research start up expenses for individuals in the same substantive fields.
- Distribution of work load was also different with a greater focus on undergraduate teaching in formal courses on the Regional Campuses and no expectation for graduate teaching or supervision.

Again, this is one department, but these factors likely explain why in some departments/schools, the markets in which the Columbus and Regional Campuses compete for faculty are completely different. This issue seems to be most problematic in the physical sciences, least in the humanities, and somewhere in between in the social sciences. There is a number of factors that contribute to this including the laboratory needs within disciplines and the proportion of new graduates available to the number of jobs available. Our analysis of the case study department suggests that under the current system and environment, it would likely be impossible for this department to hire an equivalent faculty at the Columbus and Regional Campuses. The different types of hires on the main and regional campuses have important implications when it comes time for tenure and promotion.

Just as there is diversity in hiring across academic units, there appears to be considerable diversity with respect to promotion and tenure standards as well. In some units, it appears that the standards for tenure are within a reasonable range of comparability on the Columbus and Regional Campuses. In other departments, differences are explicitly accommodated in the AP&T documents. In departments acknowledging differences, some simply acknowledge that tenure and promotion to Associate Professor is based more on teaching than research for members of the Regional Campuses. Other departments hold regional faculty to the same “quality” standard in research, but expect less in quantity of research output. This diversity in standards and criteria within one department can lead to the perception of “two categories” of faculty.

A similar situation holds when it comes to standards for promotion to Professor. In many of the major academic units (ones that are most likely to offer degrees on the Regional Campuses), promotion to Professor requires demonstration of national and international visibility and stature. Since such visibility and stature comes primarily from one’s research activities, it is often more difficult for Regional Campus faculty to meet this standard given the higher teaching load and reduced resources for research. Nevertheless, in certain disciplines (humanities, mathematics) – it may be more possible to reach this standard than in other disciplines where access to a state of the art research laboratories staffed with graduate students and postdoctoral fellows is necessary to achieve the quantity and quality of research required for national stature. Thus, in the physical and social science disciplines, the proportion of Professors on the Regional

Campuses is typically considerably smaller than it is in Columbus. This means that students on Regional Campuses will have some difficulty in interacting with individuals at the Professor rank making their experience not strictly comparable to students who obtain degrees on the Columbus campus.

Workload and salaries for faculty at Regional Campuses currently are determined by the Regional Campus Dean. They differ from the Columbus campus and they vary among the four Regional Campuses. In that regard, understandably, on the Regional Campuses it is problematic to adhere easily to the workload policy guidelines promulgated by the Office of Academic Affairs (http://oaa.ohio-state.edu/handbook/v_teachingworkload.html):

Criteria and standards for teaching and service are set at the Regional Campuses by the Deans who then evaluate faculty on these responsibilities. Most teaching is at the undergraduate level, although some Regional Campus faculty supervise master's and doctoral students. Most faculty teach 6-7 courses per year – typically more than their departmental/school colleagues in Columbus.

Columbus campus department chairpersons/school directors are responsible for evaluating Regional Campus faculty research performance. One or two quarters of released time for research is usually provided during the probationary period. Start-up packages, if any, are distributed at the Regional Campus level. At most campuses there is some seed grant or start-up money available for new faculty (usually less than \$10,000). Most campuses provide some money for travel to present a paper at professional meetings of a scholarly association or give a presentation at another university. Funds are also available to defray travel costs to the Columbus campus.

Anecdotal evidence suggests that there is disparity in research evaluation standards across departments for Regional Campus faculty. Some departments strictly apply Columbus campus standards to Regional Campus faculty. Other departments expect the same quality of research, - publishing in leading journals, presenting papers at national and international meetings - but somewhat fewer publications. In disciplines dependent on sophisticated laboratories and a cadre of graduate students it is not possible for Regional Campus faculty to meet Columbus standards unless arrangements are made for a physical presence in the main campus department sufficient to conduct a high quality research program.

The pool of funds available for salary increases at the Regional Campuses is determined by the guidelines promulgated by the Office of Academic Affairs in Columbus. The distribution of raises is determined by Regional Campus Deans based on weightings for teaching, research and service. Currently such weightings vary among Regional Campuses. Variations from these weights on each campus can be negotiated by individual faculty members with the Regional Campus Deans. Regional campus faculty are paid significantly less than their Columbus campus colleagues.

In summary, although the University is currently operating in the “one University”

model, with regard to faculty, there is not full, strict adherence to it. There is variability among academic units particularly with regard to standards and criteria for hiring, promotion, and tenure decisions. Moreover, given the special instructional environment of Regional Campuses (undergraduate emphasis with small classes) and the fact that each campus is funded separately, there is also variability in workload and compensation – between the Columbus campus and the Regional Campuses, and among Regional Campuses.

Nonetheless, it is the consensus of the Commission that the “one University” model, toward which we have been working for many years, in general is the most appropriate model for The Ohio State University at this time.

The Commission recommends that:

- **the University should adhere to the “one University” model for faculty and curriculum and work toward its achievement.**

It is important to note that the one university model does not require that all of the campuses be identical in all respects. This would neither be possible nor desirable. But, it does require that a core set of criteria and standards be defined, and that a “range of comparability” across campuses with respect to standards and criteria be identified.

Again, the Commission believes that if there is to be one common University degree in a particular subject area, that degree must be defined by more than merely a common curriculum. If we aspire to be a world class university, as proposed in the Academic Plan, then a student who receives a particular degree from a Regional Campus should have a comparable (world class) experience to those completing a degree on the Columbus campus. This implies, at a minimum, a commonality in qualified faculty and opportunities for all students in a given major program. There may be some difficulties, however, in offering a common University experience in some academic areas due to difficulty in hiring faculty or providing appropriate facilities. The implication is that degrees will **not** be offered in certain academic areas, or could not be completed solely on a Regional Campus. In addition, hiring a comparable faculty for all campuses of the University likely implies more comparable compensation and workload levels, and this may be impractical fiscally. Although the one university model has positive features (such as bringing a world class university to diverse parts of the state), there are practical considerations that may make “full” implementation unlikely.

Currently the University comes closest to this model for faculty in the academic areas where degree programs can be completed on the Regional Campuses, but even among the four of them there is, for legitimate reasons, considerable variability – English most aligned with this approach; Psychology least. And, at least half the faculty on the Regional Campuses are single representatives of their disciplines and face a different context in which to work – fewer opportunities to offer routinely upper division courses;

no cluster of faculty with whom to work closely; and issues of research infrastructure.

Although this model has been adopted, clearly there are internal complexities associated with it.

The Commission recommends that:

- **the University explore, immediately, in more detail, the approaches adopted by other institutions to determine if they could provide creative alternatives to some of the issues that need to be addressed in the “one University” model.**

The “one-system” model provides Regional Campuses with more autonomy in decisions regarding the number and type of courses, curricula, programs, and degrees offered. Under this model, campuses might be able to more readily address community needs. However this more autonomous approach might distinguish the Regional Campuses from the Columbus campus, including mission (potential for becoming teaching campuses with little or no research emphasis) and quality – something that runs counter to the Commission recommendations on mission/governance. **It is not seen as a viable alternative.**

A “hybrid” model, in some respects, provides the best of both systems above. From the one university model it retains a one University degree (rather than tagged degrees by campus). Yet, it retains the flexibility of the one system model in allowing regional campuses collectively to hire, promote, and tenure faculty by standards that can differ from those for Columbus campus faculty. It is worthy of further study.

Curriculum

In curricular terms, we do operate within the “one-University” model. All courses at the Regional Campuses are the same as those offered on the Columbus campus although ATI, with its distinctive role, offers some courses and certificate programs that are specific to ATI and not offered anywhere else in the University. All Regional Campuses and ATI offer associate degrees that are specific to those locations (not available in Columbus). ATI does not offer bachelor’s or master’s degrees but the Regional Campuses offer entire bachelor’s degrees onsite, most of which are University-wide degrees (e.g. Bachelor of Arts in Psychology, English, and History). Two undergraduate degrees are Regional Campus-specific (Bachelor of Science in Education, General Business). The Regional Campuses offer a complete graduate program in Elementary Education. Stated simply, students either at all locations or some, are offered a full array of curricular options from within the University. **And it is important to note, following the “one-University” model, that the University, not the specific campus, confers the degrees.**

The Regional Campuses enjoy a collegial partnership with the Columbus campus that enables students to take classes on more than one campus, including the Columbus campus, to complete a degree program. Students can begin most bachelor's degrees, as well as a Master's degree in Social Work, on any of the Regional Campuses and complete the degree in Columbus.

Most of the degree programs offered at the Ohio State Regional Campuses are offered in a traditional classroom setting. In recent years, however, each campus has been piloting and exploring non-traditional delivery systems such as distance learning and web-based instruction, including, effective 2001, a General Business major program being delivered in large part by the Fisher College of Business on the Columbus campus to each Regional Campus

Other public university Regional Campuses, in Ohio, offer some full bachelor's and master's degree programs, but usually none that is specific to their Regional Campuses. It is possible to earn some University degrees (not campus-specific degrees) on their Regional Campuses on a "site specific/time specific" basis. Students complete the degrees as a cohort. Most of the degree programs offered at the other campuses in Ohio, similar to our Regional Campuses, are taught in a traditional classroom setting, but Ohio University has a long tradition of use of distance education, and continues to move forward in that direction.

Among other institutions nationally that have Regional Campuses, including The Pennsylvania State University, the University of Minnesota, and the University of South Carolina, there is no one model with regard to curricular offerings. There is some mix of certificate, associate degree, and University-wide versus campus-specific bachelor's and master's degree offerings. For those that do offer bachelor's degrees through Regional Campuses, the array of options is considerably greater than at our Regional Campuses. In addition, similar to our Regional Campuses, students who attend these campuses have a seamless transition to their central campus to complete a degree. Most of the degree programs offered at the Regional Campuses of these universities are taught in a traditional classroom setting. In most cases less than a quarter of the instruction of a degree is taught using distance-learning technology. The University of South Carolina, specifically, offers 30 credit hours of instruction via distance-learning technology toward a Bachelor's degree in Interdisciplinary Study.

If the "one-University" model is to continue, the development and offering of courses and degree must be held to the same standard in all locations and determined by the academic unit(s) in Columbus campus in collaboration with the Regional Campuses. If courses are delivered by faculty who are held to the standards of the University and taught in an agreed upon manner, then few if any distinctions may be made on the offerings regardless of the location. This situation exists with regard to current degree programs in Education, English, History and Psychology. Indeed, in the case of the new General Business major, currently only available at the Regional Campuses, most of the coursework is being delivered by Columbus campus faculty via distance learning technology. The criteria and standards for the faculty, curriculum, and degree are the

same as if the degree were one offered on the Columbus campus. This is a clear example of a one-University model.

As Ohio State moves toward redefining the role of its Regional Campuses in the context of its Academic Plan, decisions will need to be made as to whether or not to expand the types and number of programs offered on its Regional Campuses. New curricular development will encounter some difficulties in this one-University model, given the variations that currently exist among Regional Campuses today, including: student population size and characteristics (demand), research and laboratory facilities, faculty work loads, and community needs. At all locations appropriate levels of funding for curricular offerings need to be assured.

Nonetheless, within the context of the Academic Plan and the changing higher education landscape in Ohio, the Commission believes that modest curricular expansion at the Regional Campuses should begin through a planning process that includes the Office of Academic Affairs. In this way there is adherence to the concept of “systemic” operations.

The Commission recommends that:

- **The Regional Campuses and the Office of Academic Affairs should now determine the feasibility of:**
 - i) expanding the number of bachelor degree programs currently only offered in Columbus, to the Regional Campuses;**

This should not be determined solely on the basis of the number of faculty in an academic discipline on the Regional Campuses. Such an approach could divide enrollments among current majors rather than attract new students. Instead consideration should be given to existing majors/degrees that are in demand in a particular community/region. Current majors in Arts and Sciences and Human Ecology, among others, are examples. A careful market analysis ought to be conducted for each of the Regional Campus communities to determine the feasibility of particular majors/degrees. Consideration might also be given to majors/degrees that are in demand by students who select a University Regional Campus as an alternative choice and end up attending an Ohio State Regional Campus

- ii) developing new degree programs that address the unique needs/features of the Regional Campuses and are specific to the Regional Campuses;**

Is there merit to Regional Campuses having Bachelor’s degrees separate from Columbus? The major programs in education and business are the two current examples. A feasibility study for such programs needs to be undertaken.

iii) developing specific degree programs on specific campuses and sharing them among all campuses.

Rather than have duplication of new majors on each of the Regional Campuses, there should be a consideration of distinctions in offerings, with one campus offering a particular major program – based either on local demand for a new distinctive major, or faculty expertise for a current major that is not yet available on a Regional campus - and sharing it with the other campuses. **Use of distance learning and other technologies to make a wider variety of majors available to Regional Campus students should be an important consideration in programmatic expansion.**

- **the Regional Campuses and the Office of Academic Affairs should also assess whether Regional Campuses should offer certificate programs, and analyze the status of its associate degrees programs.**

vi) Co-Location with a Technical College

The fact that each Regional Campus is co-located with a state-funded technical college, has widespread implications for many academic and academic-support functions; has produced the situation where today each campus has its own distinctive working relationship with its co-located college; and has important implications for long-term planning of our Regional Campuses. It is useful and important to outline the basic dimensions of current co-location relationships.

History

In 1969, a technical college was invited to share the land and facilities of each of the University's Regional Campuses. In one case (Mansfield), pre-existing technical colleges were invited; in another case (Marion), a new technical college was founded and administered separately; in the other two cases (Lima and Newark), new technical colleges were founded and the Dean of the University's Regional Campus was also named President of the new technical college. In all cases, however, the technical colleges were established as independent technical colleges under Ohio Revised Code Section 3357, each with its own Board of Trustees.

In all cases, agreements were worked out by which the Regional Campus and the technical college would share facilities and services and cooperate in other ways for their mutual advantage. Typically, the facilities and services that are shared include: Plant Operation and Maintenance, Security, Custodial Services, Library, Student Activities, Physical Activities, Food Service, Bookstore, and Child Care.

The arrangement by which one person served as the chief executive officer of the two institutions ended in Lima in 1987 but continues, as noted above, with modification, at

the Newark campus. The Newark campus continues to have much closer relationships between the two institutions than do the other three.

Shared Services

The sharing of services and facilities does yield financial savings and allows the institutions to provide better services to students than either institution could afford acting alone.

Issues have arisen in management of shared services. Most of these services have been managed by the Regional Campus and the technical college has reimbursed the University under pre-agreed formulas. At times there have been disputes over budgetary matters. At other times the technical college has raised issues of quality of service and of control. Except on the Newark campus, there is no authority which can adjudicate disagreements. In recent years, the Regional Campus trustees have sometimes interacted with the technical college trustees to help resolve shared services issues. Such issues have not significantly affected the academic enterprise.

Facilities

Historically, the technical colleges had a much easier time acquiring capital facilities than did the Regional Campuses. The Regional Campuses competed with needs of the Columbus campus and rarely came to the top of a priority list. By contrast, the technical colleges were rapidly growing and had direct access to the Board of Regents and the legislature. Furthermore, the laws under which technical colleges were operating are considerably less restrictive than those governing universities. As a consequence, most construction between 1975 and 1995 was done under the aegis of the technical college even when the facility was built for the benefit of both institutions.

This situation changed in 1996 with the change in Ohio's method of financing capital construction. Now each institution has its separate, formula-based, allocation of capital component funds and is expected to exercise its judgment as to how these funds are used. This change in the method of financing capital construction came shortly after the creation of the Regional Campuses' Boards of Trustees and these Boards have taken an active role in the planning of capital projects of their respective campuses.

The Regional Campuses and co-located technical colleges sometimes construct capital projects independently and at other times agree to jointly fund a project for mutual benefit. Each such occurrence is separately negotiated between the two institutions.

Transfer Issues

There is a wide-spread perception in the technical colleges, as well as in the community at large, that the University is unreasonably restrictive in accepting transfer credit from

the co-located technical colleges. Students who transfer from one institution to the other often lose a significant number of credits. To an extent, this is the inevitable consequence of students changing career directions. Academics on both sides understand that a change from a technology major to a liberal arts will entail loss of credits, as would, for example, a change from anthropology into engineering technology. Many would like to believe that once a credit has been paid for it should be universally applicable.

Somewhat more difficult to explain is the situation when courses have similar titles and content but different standards. The business major is a particular example of this sort. The Ohio State University business degree program is American Association of Colleges and Schools of Business (AACSB)- certified, and one of the requirements of this certification is that business courses have calculus prerequisites. The technical colleges all have business technology programs and in those programs many courses have similar names and content to Ohio State business courses. These courses are not calculus based and will not and cannot be accepted toward an Ohio State business degree.

Mission Revision

The technical colleges have a statutory mission defined in the Ohio Revised Code Section 3357. This mission is complementary to The Ohio State University mission of baccalaureate education. In recent years, technical colleges have been expanding their mission to include a university transfer mission.

Ohio Revised Code Section 3357.01 defines their mission as follows:

- (A) “Technical college” means an institution of education beyond high school, including an institution of higher education, organized for the principal purpose of providing for the residents of the technical college district, wherein such a college is situated, any one or more of the instructional programs defined in this section as “technical college,” or “adult-education technical programs,” normally not exceeding two years duration and not leading to a baccalaureate degree.

- (D) “Technical college program” means a post high school curricular program provided within a technical college, planned and intended to qualify students, after satisfactory completion of such a program, normally two years in duration, to pursue careers in which they provide immediate technical assistance to professional or managerial persons generally required to hold baccalaureate or higher academic degrees in technical or professional fields. The technical or professional fields referred to in this section include, but are not limited to, engineering and physical, medical, or other sciences.

- (E) “Adult-education technical programs” means the dissemination of post high school technical education service and knowledge, for the occupational, or general educational benefit of adult persons.

In November 1990 the Ohio Board of Regents created a transfer and articulation policy. This policy was designed to facilitate transfers and, thereby, increase degree completion. The application of this policy to co-located campuses was clarified in a letter from the staff of The Ohio Board of Regents dated August 5, 1991. It reads in part: "...missions are clearly differentiated...nor will a change in institutional mission be represented or advertised... an operational statement on advertising will be developed by each pair of co-located campuses... the Board of Regents will become the final arbiter..."

The co-located technical colleges have increasingly been advertising a transfer mission. In some cases they have invited other colleges and universities onto the shared campus to offer courses that are in direct competition with Ohio State University courses. They have not only advertised a transfer mission, but have emphasized it by creating and publicizing articulation agreements with other colleges and universities. Indeed, North Central Technical College and Lima Technical College changed their names and now refer to themselves as "state colleges".

These changes have altered the basic premise that the technical colleges and the universities have complementary missions.

Branding

Having The Ohio State University and a technical college on the same campus has made it more difficult to create a clear Ohio State identity. Signage advertises both institutions or, in the case of Newark, features "the Newark campus" rather than emphasizing the identity of either. Explanations are needed for campus visitors. Technical college students sometimes misidentify that they are attending The Ohio State University.

Often the community itself does not have a clear understanding of the situation. For example, the University is sometimes criticized for not being as helpful as the technical college in workforce training of a sort clearly within the technical colleges' mission.

Commission members have come to understand better the myriad of issues that accompanies co-location, and do not believe that there is any one solution to address all of them. Indeed, identifying and implementing **one model** that could be adopted either quickly or easily at **all** locations for both institutions, is highly unlikely at this time. The co-location development paths taken at each location are too distinct.

However, the Regional Campuses are an integral part of the University's Academic Plan, and any/all issues that arise from co-location that affect that role need to be identified and addressed. To date, generally, such issues have been handled in a piecemeal manner.

The Commission recommends that:

- **the University administration begin to monitor more closely issues that are related to co-location and determine their effects on Regional Campus planning.**

This process should be aided by the recommendation that the Executive Vice President and Provost should identify ways to enhance stronger co-ordination of Regional Campus issues.

Appendix I

The regional campuses are part of The Ohio State University and, as such, share the vision, purpose, core values, and future goals of the University's strategic plan. Following is The Ohio State University's vision, highlighting the unique role of the regional campuses in specific areas.]

The Ohio State University Vision

Purpose: To advance the well-being of the people of Ohio and the global community through the creation and dissemination of knowledge.

Core Values

- b. Pursue knowledge for its own sake.
- c. Ignite in our students a lifelong love of learning.
- d. Produce discoveries that make the world a better place.
- e. Celebrate and learn from our diversity.
- f. Open the world to our students.

Overarching Goal: The Ohio State University will be among the world's truly great universities.

Future

The Ohio State University will be recognized worldwide for the quality and impact of its research, teaching, and service *conducted on each of our campuses*. Our students will be able to learn and to advance knowledge in all areas. As a 21st century land-grant university, The Ohio State University will set the standard for the creation and dissemination of knowledge in service to its communities, state, nation, and the world. Our faculty, students, and staff will be among the best in the nation.

Our regional campuses will expand the reach of the University's research, teaching, and service efforts and serve as valuable educational resources to each region in Ohio. They will offer courses and a select number of degree programs from the OSU curriculum.

Academic excellence will be enriched by an environment that mirrors the diverse world in which we live. Within this environment, we will come to value the differences in one another along with the similarities, and to appreciate that the human condition is best served through understanding, acceptance, and mutual respect. Throughout the learning process, our faculty and staff will find the highest levels of fulfillment and satisfaction as they collaborate to educate and support a student body recognized for its scholarship and integrity.

Students will have the opportunity to learn on our campuses or from locations around the world through the innovative use of technology. The quality of our physical facilities and grounds *on all campuses* will be consistent with our world-class status. Extracurricular activities will support the personal growth of all members of our community. Our intercollegiate athletic programs will routinely rank among the elite few.

Graduation rates for all students will compare favorably with the nation's best public universities. Most of all, our graduates will be among the most sought after by the world's best employers and will become leaders in their communities and accomplished professionals in their chosen work. We will lead Ohio to a dynamic knowledge economy, and our research, widely known for its multidisciplinary programs, will help solve the most challenging social, cultural, technical, and health-related problems.

Regional campuses will provide entry for students who may not otherwise have access to Ohio State and will prepare those students to successfully complete degrees. The excellence of our programs will be recognized by the highest levels of public and private support. As a result, The Ohio State University will earn an intensity of alumni loyalty and of public esteem unsurpassed by any other university

Appendix II

PROPOSED BYLAWS
THE OHIO STATE UNIVERSITY – REGIONAL CAMPUS
BOARD OF TRUSTEES

3335-115-01 COMPOSITION AND ADMINISTRATION OF THE BOARD

- (A) THE OHIO STATE UNIVERSITY BOARD OF TRUSTEES ("THE UNIVERSITY BOARD") HEREBY ESTABLISHES A BODY TO BE KNOWN AS THE OHIO STATE UNIVERSITY – XXXXX BOARD OF TRUSTEES ("THE XXXXX BOARD").
- (1) THE XXXXX BOARD SHALL BE COMPOSED OF ELEVEN MEMBERS APPOINTED BY THE UNIVERSITY BOARD IN CONNECTION WITH THE PRESIDENT OF THE UNIVERSITY.
 - (2) ONE MEMBER OF THE XXXXX BOARD SHALL BE A MEMBER OF THE UNIVERSITY BOARD (THE "TRUSTEE MEMBER"). NINE MEMBERS SHALL BE PRIVATE CITIZENS WHO RESIDE WITHIN THE AREA SERVED BY THE INSTITUTION. ONE MEMBER OF THE XXXXX BOARD SHALL BE A STUDENT WHO IS CURRENTLY ENROLLED AND IN GOOD STANDING AT THE XXXXX CAMPUS. THE STUDENT MEMBER SHALL HAVE NO VOTING POWER ON THE BOARD.
 - (3) CITIZEN MEMBERS SHALL BE APPOINTED FOR TERMS OF THREE YEARS. TERMS WILL BE STAGGERED SO THAT THREE TERMS END EACH YEAR. IN CASE A VACANCY DEVELOPS, THE UNIVERSITY BOARD MAY APPOINT A CITIZEN MEMBER TO FILL THE REMAINING PART OF THE UNEXPIRED TERM. NO CITIZEN MEMBER SHALL SERVE MORE THAN THREE CONSECUTIVE TERMS. (IN DETERMINING ELIGIBILITY FOR REAPPOINTMENT, AN INITIAL APPOINTMENT OF LESS THAN TWO YEARS SHALL NOT BE CONSTRUED AS A TERM.)
 - (4) THE STUDENT MEMBER SHALL SERVE A TERM OF ONE YEAR, AND IS ELIGIBLE FOR REAPPOINTMENT AS LONG AS HE OR SHE REMAINS A STUDENT IN GOOD STANDING AT THE XXXXX CAMPUS.

- (5) THE TRUSTEE MEMBER SHALL SERVE A TERM OF THREE YEARS AND MAY BE REAPPOINTED SO LONG AS HE OR SHE REMAINS A MEMBER OF THE UNIVERSITY BOARD.
- (6) TERMS OF ALL MEMBERS SHALL BEGIN ON JULY 1.
- (7) MEMBERS OF THE XXXXX BOARD SHALL SERVE WITHOUT COMPENSATION BUT MAY BE REIMBURSED FOR EXPENSES INCURRED IN THE PERFORMANCE OF THEIR DUTIES. MEMBERS OF THE XXXXX BOARD SHALL BE PROVIDED IMMUNITIES OR INDEMNIFICATION AGAINST ANY CLAIMS OR LIABILITIES WHICH MAY ARISE FROM THE PERFORMANCE OF THEIR DUTIES TO THE FULL EXTENT PERMITTED BY LAW.
- (8) THE DEAN/DIRECTOR OF THE XXXXX CAMPUS SHALL ASSIST THE CHAIR OF THE XXXXX BOARD IN ESTABLISHING BOARD AGENDAS AND PRIORITIES AND SHALL PROVIDE SUCH STAFF SERVICES AND OTHER ASSISTANCE AS THE BOARD MAY REQUIRE. THE DEAN/DIRECTOR MAY ATTEND ALL MEETINGS OF THE BOARD.
- (9) THE PROVOST OR THE PROVOST'S DESIGNEE, IN COOPERATION WITH THE DEAN/DIRECTOR, SHALL SERVE AS THE LIAISON BETWEEN THE XXXXX BOARD AND THE VARIOUS COLLEGES AND DEPARTMENTS OF THE UNIVERSITY, AND MAY ATTEND ALL MEETINGS OF THE XXXXX BOARD.
- 10) THE CHAIR OF THE XXXXX CAMPUS FACULTY ASSEMBLY SHALL SERVE AS A RESOURCE PERSON FOR THE XXXXX BOARD AND, IN ORDER TO SERVE THAT FUNCTION, MAY ATTEND ALL PUBLIC MEETINGS OF THE XXXXX BOARD.

3335-115-02 POWERS AND DUTIES

- (A) THE XXXXX BOARD SHALL ADVISE AND ASSIST THE DEAN/DIRECTOR IN THE ADMINISTRATION OF THE XXXXX REGIONAL CAMPUS. SUBJECT TO THE AUTHORITY AND PERIODIC REVIEW OF THE UNIVERSITY BOARD, THE XXXXX BOARD SHALL:

- (1) DEVELOP SUPPORT FOR THE XXXXX REGIONAL CAMPUS IN ITS SERVICE AREA;
 - (2) ADVISE THE DEAN/DIRECTOR CONCERNING LOCAL EDUCATIONAL NEEDS, AND PERCEPTIONS OF UNIVERSITY PROGRAMS;
 - (3) SERVE AS AN ADVOCATE FOR THE NEEDS OF THE XXXXX REGIONAL CAMPUS IN LOCAL AND STATE GOVERNMENT AGENCIES, AND IN THE LEGISLATURE;
 - (4) PARTICIPATE IN STRATEGIC PLANNING FOR THE XXXXX CAMPUS;
 - (5) REVIEW AND FORMALLY RECOMMEND THE CURRENT FUNDS BUDGETS OF THE XXXXX CAMPUS PRIOR TO SUBMISSION TO THE UNIVERSITY BOARD BY THE PRESIDENT;
 - (6) IN COOPERATION WITH THE BOARDS OF THE OTHER OHIO STATE UNIVERSITY REGIONAL CAMPUSES, RECOMMEND TO THE UNIVERSITY BOARD RATES FOR REGIONAL CAMPUS TUITION AND FEES.
 - (7) FORMALLY APPROVE ALL CAPITAL PROJECTS OF THE XXXXX CAMPUS IN AT LEAST THE FOLLOWING STAGES: ADOPTING A FUNDING PLAN, HIRING AN ASSOCIATE ARCHITECT, AND GOING OUT FOR BIDS.
 - (8) REVIEW THE PERFORMANCE OF THE XXXXX CAMPUS DEAN/DIRECTOR; REPORT THE RESULTS OF SUCH REVIEWS ANNUALLY TO THE PROVOST; AND AT APPROPRIATE TIMES MAKE A RECOMMENDATION TO THE PROVOST REGARDING RENEWAL OF THE DEAN/DIRECTOR'S APPOINTMENT.
 - (9) COORDINATE WITH THE BOARD OF THE (CO-LOCATED TECHNICAL COLLEGE) IN ALL AREAS OF COMMON INTEREST.
- (B) THE HIRING, EVALUATION, PROMOTION, TENURE STATUS, DUTIES AND RESPONSIBILITIES, AND COMPENSATION OF FACULTY SHALL BE CONDUCTED IN ACCORDANCE WITH ESTABLISHED UNIVERSITY RULES AND THE XXXXX BOARD SHALL HAVE NO JURISDICTION WITH RESPECT TO THESE MATTERS.

- (C) TO ENSURE THAT THE UNIVERSITY BOARD OF TRUSTEES MEETS ITS GOVERNANCE OBLIGATIONS UNDER OHIO LAW, THE XXXXX BOARD WILL BE ACCOUNTABLE, THROUGH THE PRESIDENT, TO THE UNIVERSITY BOARD.
- (1) THE APPOINTMENT OF THE DEAN/DIRECTOR WILL BE APPROVED BY THE UNIVERSITY BOARD OF TRUSTEES IN ACCORDANCE WITH RULE NO. 3335-3-291 OF THE ADMINISTRATIVE CODE FOLLOWING CONSULTATION WITH THE XXXXX BOARD.
- (2) RECOMMENDATIONS AND REPORTS OF THE XXXXX BOARD THAT REQUIRE THE UNIVERSITY BOARD OF TRUSTEES' REVIEW OR ACTION WILL BE COMMUNICATED IN A TIMELY MANNER TO THE UNIVERSITY BOARD THROUGH THE PRESIDENT.
- (3) THE UNIVERSITY BOARD OF TRUSTEES WILL CONTINUE TO HOLD THE PRESIDENT RESPONSIBLE FOR THE CONDUCT OF ACADEMIC PROGRAMS AND FOR ENSURING THAT THE REGIONAL CAMPUS IS OPERATED IN A MANNER CONSISTENT WITH UNIVERSITY POLICY, AS WELL AS STATE AND FEDERAL LAW.

3335-115-03 MEETINGS

- (A) REGULAR MEETINGS OF THE XXXXX BOARD SHALL BE HELD EACH MONTH, OR ON SUCH OTHER SCHEDULE AS MAY BE ESTABLISHED BY THE BOARD, AT TIMES WHICH SHALL BE SET AND PUBLICLY ANNOUNCED BY THE CHAIR.
- (B) SPECIAL MEETINGS MAY BE CALLED AT THE DIRECTION OF THE CHAIR, OR SHALL BE CALLED BY THE CHAIR AT THE REQUEST OF THREE MEMBERS OF THE XXXXX BOARD, PROVIDED THAT NOTICE TO ALL BOARD MEMBERS SHALL BE GIVEN NOT LESS THAN FIVE DAYS PRIOR TO THE MEETING.
- (C) EXCEPT AS OTHERWISE SPECIFIED IN THESE BYLAWS, ALL MEETINGS OF THE XXXXX BOARD AND ITS COMMITTEES SHALL BE CONDUCTED IN ACCORDANCE WITH THE LATEST REVISION OF "ROBERT'S RULES OF ORDER."
- (D) MEETINGS OF THE XXXXX BOARD SHALL BE OPEN TO THE PUBLIC, EXCEPT FOR EXECUTIVE SESSIONS CALLED FOR REASONS PERMISSIBLE UNDER OHIO LAW.

(E) A MAJORITY OF THE CURRENT CITIZEN MEMBERSHIP OF THE XXXXX BOARD SHALL BE NECESSARY FOR A QUORUM.

(F) MOTIONS MAY BE PASSED BY A MAJORITY OF THE VOTING MEMBERS PRESENT.

3335-115-04 VACANCIES AND REMOVAL

(A) VACANCIES SHALL BE FILLED BY THE UNIVERSITY BOARD OF TRUSTEES IN THE SAME MANNER AND SUBJECT TO THE SAME QUALIFICATIONS AS APPOINTMENTS FOR FULL TERMS.

(B) MEMBERS OF THE XXXXX BOARD SERVE AT THE PLEASURE OF THE UNIVERSITY BOARD OF TRUSTEES.

(C) ANY XXXXX BOARD MEMBER WHO HAS THREE UNEXCUSED ABSENCES FOR THREE SUCCESSIVE MEETINGS, OR FIVE UNEXCUSED ABSENCES IN ANY CALENDAR YEAR, SHALL BE A AUTOMATICALLY REMOVED.

3335-115-05 OFFICER

(A) THE XXXXX BOARD SHALL SELECT A CHAIR, A VICE CHAIR, AND A SECRETARY. OFFICERS SHALL BE ELECTED ANNUALLY, BY JULY 1ST, BY THE XXXXX BOARD. NO OFFICER MAY SERVE MORE THAN TWO CONSECUTIVE ONE-YEAR TERMS IN THE SAME OFFICE.

(B) THE CHAIR SHALL PRESIDE AT ALL MEETINGS OF THE BOARD, SHALL APPOINT MEMBERS OF ANY COMMITTEES CREATED BY THE BOARD, SHALL SERVE AS AN EX-OFFICIO MEMBER OF ALL STANDING AND SPECIAL COMMITTEES, SHALL APPROVE THE AGENDA FOR ALL BOARD MEETINGS, AND SHALL MAKE AN ANNUAL REPORT TO THE UNIVERSITY BOARD OF TRUSTEES AND SUCH OTHER REPORTS AS THE UNIVERSITY BOARD OF TRUSTEES MAY REQUIRE.

(C) THE VICE CHAIR SHALL PERFORM THE DUTIES AND EXERCISE THE POWERS OF THE CHAIR DURING THE ABSENCE OF THE CHAIR OR IN THE EVENT OF THE CHAIR'S INABILITY TO ACT.

(D) THE SECRETARY SHALL BE RESPONSIBLE FOR PRODUCING

AND MAINTAINING MINUTES OF BOARD MEETINGS, FOR KEEPING THE TRUSTEE MEMBER INFORMED ON BOARD ACTIVITIES AND CAMPUS ISSUES, AND FOR CONDUCTING CORRESPONDENCE OF THE BOARD.

3335-115-06 COMMITTEES

- (A) THE XXXXX BOARD SHALL ESTABLISH AN EXECUTIVE COMMITTEE, A FINANCE COMMITTEE, A CAMPUS FACILITIES AND PLANNING COMMITTEE, A STUDENT LIFE COMMITTEE, AND SUCH OTHER COMMITTEES AS IT MAY FROM TIME TO TIME DEEM ADVISABLE.
- (1) THE EXECUTIVE COMMITTEE SHALL CONSIST OF THE OFFICERS AND THE TRUSTEE MEMBER OF THE XXXXXBOARD. THE EXECUTIVE COMMITTEE SHALL HAVE THE POWER TO TRANSACT SUCH BUSINESS OF THE BOARD BETWEEN REGULAR MEETINGS OF THE BOARD AS THE BOARD MAY HEREINAFTER AUTHORIZE. ALL ACTIONS OF THE EXECUTIVE COMMITTEE SHALL BE REPORTED TO THE FULL BOARD AT ITS NEXT REGULAR MEETING.
 - (2) THE FINANCE COMMITTEE SHALL CONSIST OF THREE BOARD MEMBERS APPOINTED ANNUALLY BY THE CHAIR OF THE BOARD.THE FINANCE COMMITTEE SHALL BE RESPONSIBLE FOR ADVISING THE XXXXX BOARD ON CAMPUS FINANCIAL MATTERS.
 - (3) THE CAMPUS FACILITIES AND PLANNING COMMITTEE SHALL CONSIST OF THREE XXXXX BOARD MEMBERS, APPOINTED ANNUALLY BY THE CHAIR OF THE BOARD. IT WILL MONITOR THE CONDITION OF THE CAMPUS FACILITIES AND SHALL HAVE THE RESPONSIBILITY FOR LONG-RANGE CAMPUS PLANNING, AND FOR RECOMMENDING ADDITIONS, ALTERATIONS, REPAIR AND MAINTENANCE, AND CAPITAL BUILDING PROJECTS.
 - (4) THE STUDENT LIFE COMMITTEE SHALL CONSIST OF THREE XXXXX BOARD MEMBERS, APPOINTED ANNUALLY BY THE CHAIR OF THE BOARD. IT WILL REVIEW ALL SERVICES PROVIDED TO STUDENTS TO ASSURE AN EFFECTIVE ENVIRONMENT FOR LEARNING AND A STRONG ORIENTATION TO CONSUMER SERVICE. THE COMMITTEE WILL EVALUATE REGISTRATION, FINANCIAL AID, ATHLETICS, CULTURAL AND STUDENT

ACTIVITY PROGRAMS AS WELL AS EXTRA-CURRICULAR PROGRAMS.

- (4 OR 5) THE XXXXX BOARD MAY, BY MAJORITY VOTE, ESTABLISH AD HOC COMMITTEES FOR PARTICULAR DEFINED PURPOSES AND PARTICULAR DEFINED DURATIONS.

3335-115-07 NOMINATIONS

- (A) THE XXXXX BOARD , IN CONSULTATION WITH THE CAMPUS DEAN/DIRECTOR, SHALL ANNUALLY NOMINATE TO THE UNIVERSITY BOARD PERSONS SUITABLE FOR APPOINTMENT OR REAPPOINTMENT TO THE XXXXX BOARD.
- (B) THE FOLLOWING CRITERIA SHALL GUIDE THE XXXXX BOARD IN ITS NOMINATIONS OF COMMUNITY MEMBERS:
- (1) RESIDES IN THE PRIMARY SERVICE AREA OF THE CAMPUS AND IS WELL ACQUAINTED WITH THE REGION;
 - (2) HAS A STRONG INTEREST IN THE XXXXX CAMPUS AND IN THE OHIO STATE UNIVERSITY;
 - (3) HAS A RECORD OF COMMUNITY SERVICE;
 - (4) CONSIDERATION SHOULD BE GIVEN TO NOMINATING INDIVIDUALS FROM DIVERSE PARTS OF THE SERVICE DISTRICT WITH DIVERSE PROFESSIONAL EXPERTISE AND PERSPECTIVES.
 - (5) EMPLOYEES OF THE UNIVERSITY, EMERITUS FACULTY OF THE UNIVERSITY, EMPLOYEES OF (CO-LOCATED TECHNICAL COLLEGE), AND MEMBERS OF THE BOARD OF (CO-LOCATED TECHNICAL COLLEGE) ARE INELIGIBLE TO SERVE AS CITIZEN MEMBERS.
- (C) STUDENT MEMBERS SHOULD BE STUDENTS IN GOOD STANDING, WITH AN ACTIVE INTEREST IN IMPROVING THE CAMPUS, WHO ARE WILLING TO INFORM THEMSELVES ABOUT AND REPRESENT THE CONCERNS OF OTHER STUDENTS.
- (D) NOMINATIONS WILL BE COMMUNICATED TO THE UNIVERSITY BOARD THROUGH THE PRESIDENT NO LATER THAN APRIL 20TH OF EACH YEAR SO THAT THE UNIVERSITY BOARD MAY MAKE APPOINTMENTS IN ITS MAY MEETING

THE OHIO STATE UNIVERSITY
OFFICIAL PROCEEDINGS OF THE
ONE THOUSAND THREE HUNDRED AND EIGHTY-SEVENTH MEETING
OF THE BOARD OF TRUSTEES

Columbus, Ohio, October 4, 2002

The Board of Trustees met at its regular monthly meeting on Friday, October 4, 2002, at The Ohio State University Longaberger Alumni House, Columbus, Ohio, pursuant to adjournment.

**

**

**

Minutes of the last meeting were approved.

**

**

**

October 4, 2002 meeting, Board of Trustees

The Chairman, Mr. Patterson, called the meeting of the Board of Trustees to order on October 4, 2002, at 9:55 a.m. He requested the Secretary to call the roll.

Present: James F. Patterson, Chairman, Zuheir Sofia, Tami Longaberger, Daniel M. Slane, Robert M. Duncan, Dimon R. McFerson, Jo Ann Davidson, Douglas G. Borrer, Joseph A. Shultz, and Paula A. Habib.

--0--

CHAIRMAN'S REPORT

Mr. Patterson:

First, I'd like to welcome Dr. Karen Holbrook to her first meeting as president of The Ohio State University. On Monday afternoon many of us were at a reception wherein we honored Ed Jennings for his services as interim president of the University. Then on Tuesday morning, a number of us, including the OSU cheerleaders, gathered in front of Bricker Hall to welcome Dr. Holbrook on her first day as president of the University.

At that welcoming ceremony, we had the opportunity to have a wonderful thing happen and it was so special that we wanted to share that with all of you today. David Citino, professor of English, composed a poem especially for Dr. Holbrook, and we have asked David if he would come this morning and read that poem. David –

Professor David Citino:

Thank you very much. It is an honor for me to appear before you again. What means much to me is that the University, this body and other aspects of the University, value poetry – the written and spoken word -- and are willing to use it in such a public forum.

A WELCOME TO THE PRESIDENT

Born a cross between a Hawkeye and Cyclone
in Des Moines, you transformed yourself,
using the everyday miracles of zoology,
into a scrabbling Badger whose province

is the stony patience learned in burrows.
Not content, you rose to cooperative ventures
as a team player, trusty Husky running hard
all day for greater good of each and all.

You weren't finished. Impossible nearly
to imagine, with that kind and easy demeanor,
charming smile, you became a Bulldog,
pugnacious growler guarding those

A WELCOME TO THE PRESIDENT (contd)

you hold most dear. In the midst of this,
you learned the ways of one who feels at home
in earth and water both, a Gator who bides
her time, mistress of strength and cunning.

Now, this day, you've come to us, not
to metamorphose yet again, but to share
that wisdom gained from creatures
of your totem, every life lived earlier,

finally an Ohioan. The newest Buckeye,
you're not a nut but one possessed of that eye
of the deer the ruddy, old ones admired,
far-seeing, quick to discern. Our place

is now your place, this university and state,
and we all are round on the ends and high
in the middle with joy to say those words
we've waited years and years to say,

We welcome you, President Karen Holbrook.

–David Citino

Mr. Patterson:

Thank you so much. I have been a secret admirer of David and his work for some time. I think many of you remember that he gave a commencement address, he wrote a special piece after 9/11, and he has done so many other wonderful things for the University.

The Board would like to take the opportunity to thank you and to formally recognize you for this special wonderful talent that you have. I would like to recommend to the Board a resolution that I would like to read:

TRIBUTE TO DAVID CITINO

Resolution No. 2003-39

WHEREAS David Citino, Professor of English, has provided excellent service to The Ohio State University since 1974 as a teacher, scholar, and active member of the campus and surrounding community; and

WHEREAS in filling these responsibilities so well, he has also brought to the Creative Writing Program, the Department of English, and the University considerable renown by means of his twelve volumes of poetry, his edited collection of prose, a long list of publications in prestigious journals and anthologies, and an equally long list of prestigious fellowships, awards, and honors; and

TRIBUTE TO DAVID CITINO (contd)

WHEREAS this teacher and scholar models, both in his words and in the life that he leads, the power of affirmation as he so charismatically encourages all around him to be thoughtful and imaginative; and

WHEREAS this champion of words well-used demonstrates with style and grace that poetry is the language of a free, just, and humane world; and

WHEREAS this master wordsmith has used his creativity time and time again to bring us joy at moments of celebration, inspiration on occasions for reflection, and solace at times of profound sadness:

NOW THEREFORE

BE IT RESOLVED, That on this day, October 4, 2002, The Ohio State University celebrates this remarkable human being, highly esteemed faculty member, and extraordinary poet; and

BE IT FURTHER RESOLVED, That in marking this day, the Board of Trustees of this great university is privileged to name David Citino, a native son of the State of Ohio, Poet Laureate of The Ohio State University.

[*Vote was taken as part of the Consent Agenda.]

Professor Citino:

Thank you.

Mr. Patterson:

We asked Jackie Royster, a member of the Presidential Search Committee, as associate dean in Michael Hogan's college and a good friend of David's, if she would help us craft that resolution. What a wonderful moment that was on Tuesday morning.

--0--

PRESIDENT'S REPORT

President Karen A. Holbrook:

Let me begin by thanking all of you for the absolutely wonderful welcome I have had every time I've been here and every day this week. David, you certainly made that welcome ever more poignant than it could possibly be, so thank you very much. I'm glad we had the opportunity to turn the tables on you today, because you are more than deserving for all that you've done.

After three days I hardly feel like an expert to give a report to this esteemed group, and to all of you in the audience, but I will. I have the great privilege of opening my remarks today with an announcement that is very important for The Ohio State University, very important for Columbus, and very important for our state. We are announcing the award of a collaborative grant between The Ohio State University, the Columbus Public Schools, and the Ohio Historical Society.

This is a grant from the Department of Education for \$1 million over three years to work toward the professional development of teachers of history and civics in our public schools. This is a very important outreach grant that connects the kinds of things that we do within the institution with what we're trying to do in the city, and that is improve education for our children and improve teachers. This is a grant that is going to really focus on those activities. Columbus Public Schools

PRESIDENT'S REPORT (contd)

President Holbrook: (contd)

have been doing this for some time, and our cross-University initiatives in P-12 education have been doing the same thing. This is really going to be a very important grant together.

Let me mention that we have a number of people here in the audience today to help celebrate and to tell us a little bit about this grant, and I have a few words that I'm going to add. I'd like to introduce and ask to stand: Dr. Gene Harris, superintendent of Columbus Public Schools; Dr. Gary Ness, executive director of the Ohio Historical Society; Dr. Ken Andrien, chairperson of the Department of History; and Executive Dean Michael Hogan. I know the four of you will be happy to talk with the press at more length after we've said a little bit more about the grant.

The grant is intended to improve teaching of American history in our middle schools and high schools. The grant is called, "History Works." It is a very important grant because the problem of what our citizens and students know about history is rather large. An assessment that took place last year suggested that 57 percent of the graduating seniors know very little about United States' history. As I read that statistic, I thought: I wonder what the percentage would be if you took the population as a whole? My bet is that what the high school seniors know, is a whole lot more than what the general population knows. So I do think this is a very valuable grant.

The award of this grant is also a very important one in that there were 469 applicants for the grant. The grant that we submitted collaboratively ranked #12 across the nation and ranked #1 among Big Ten schools, so we can be very proud of that. I'm actually not surprised because our History Department is one that has received awards for excellence in teaching and also a Selective Investment Award. So when you have quality, you put out quality, you deal with quality, and you work with very good people outside. This is a wonderful outreach and collaborative program.

It's also an important time for this grant to take place, as the state has new standards for history and social studies. This grant is going to feed into improving those goals and those standards. I am very excited that this grant has been awarded to all of us. I'd also like to thank Representatives Pryce and Tiberi for their support in helping this grant become a reality for our three organizations.

I would now like to ask Dr. Harris if she would like to add a few words about this wonderful announcement today.

Dr. Gene Harris:

Thank you, Dr. Holbrook, for inviting us here, and thank you, Trustees, for giving us a few minutes to say how absolutely delighted we are that we are entering into this collaborative arrangement with The Ohio State University, the Ohio Historical Society, and the Columbus Public Schools.

As you know, we have been very focused on increasing our academic performance. We know that increasing our reading and writing across-the-board will certainly help our students. We also know that after the tragedy of 9/11, it is especially important for our young people to understand the history of their country, the places that they have in the world, and to be very prepared to go out into our society and take their places.

PRESIDENT'S REPORT (contd)

Dr. Harris: (contd)

As I was reading the grant, I was excited about the fact that our teachers will be involved with the Ohio Historical Society, where there are a half million artifacts. I just told Dr. Ness that I'd like to stand and be up to my neck in a half million artifacts. How wonderful and fun it will be for urban education and urban teachers to have this opportunity to work with archivists and historians, and to really bring history off the written page and make it come alive for our students.

I'm very excited about this opportunity and excited for what it will do for the professionals in our schools, as well as the learning of our students. Thank you very much.

President Holbrook:

Thank you. Dr. Ness, would you like to make any remarks?

Dr. Gary C. Ness:

Dr. Holbrook and members of the Board, thank you very much. We at the Ohio Historical Society not only applaud and welcome this opportunity for collaboration and partnership, but, in particular, what we see is going to happen and unfold over the next many months is helping us make what had heretofore been some very difficult decisions about which items in this mass of material are of greatest interest and most immediate usefulness to students and teachers. That winnowing process is best done in consultation with the users and those who are ultimately going to appreciate it.

I would echo Dr. Holbrook's and Dr. Harris' words about the way that history is a marvelous vehicle for accelerating reading and writing abilities. It gives those students something to write about, which we think is very important.

Thank you very much, we look forward to this.

President Holbrook:

Thank you. Dr. Andrien, would you like to make any comments on behalf of OSU and the Department of History?

Professor Kenneth J. Andrien:

Thank you, members of the Board, and thank you, Dr. Holbrook, for this opportunity. This is a wonderful day to celebrate a partnership, and it's a partnership that we believe in very strongly. As you pointed out, it was one of the most successful grants in the country. That comes from the kind of quality that the department brings and the kind of partnership we can bring to the Columbus Public Schools.

I'd like to thank our director of the Goldberg Program, John Tully, who was responsible for initiating some of the initial connections. I'd also like to thank Dean Michael Hogan, who established the Goldberg Program, which set up the institutional basis for allowing us to undertake this kind of outreach and make it possible. This is an opportunity to really establish a national model for this level of cooperation between a major academic department and an urban public school district, as well as the Ohio Historical Society. In all of those ways, it's a day to celebrate. Thank you.

PRESIDENT'S REPORT (contd)

President Holbrook:

Thank you very much. I really do think the fanfare for this grant is absolutely appropriate. We so often celebrate our successes in science because they come much more readily and there are so many more funding opportunities. When we have these extraordinary grants that have every element of what it is we're trying to do – reach out, continuity of education, interdisciplinary connections -- this is the ideal grant. I'm thrilled that we can celebrate this today. Thank you.

Normally, I'll tell you what's going on at the University that is exciting or that's happened in the past month. Today there are a couple of things that I had thought about mentioning, but since I only have three days of history here to talk about, I'm not going to do that. I'm going to talk about a couple of things that I think are somewhat important related to the Academic Plan, as this is what really is driving us and our future, and the quality that we want to achieve.

I'm going to review very fast what the six goals are and then tell you something about them: 1) a world-class faculty -- we've seen today that we have a world-class faculty when we can bring in these awards; 2) academic programs that have defined Ohio State as the nation's leading public land-grant university -- the grant's announcement today is another example of what we're doing; 3) improving the quality of teaching and learning environment -- we're doing it here on campus and all over the city, and we're meeting that goal; 4) enhance and better serve the student body; 5) create a more diverse university community; and 6) help build Ohio's future. I think all of those really are embodied in this grant.

What I want to talk a little bit about are the metrics that we use to evaluate those goals. I'm going to focus on only two things today: 1) the national benchmarking of our success; and 2) the implementation strategies for the Academic Plan.

Let me start first with the benchmarking measures of success. All of you know that we have our own measures internally of how we benchmark our success on the Academic Plan. We've done a follow-up, we've looked at year one, and where we've improved or stayed stable in those rankings.

What we also have to consider is the national rankings. I know all of you are very well aware that universities' programs and a variety of other activities at universities are ranked nationally. We look at research rankings, we look at faculty salaries, we look at our library holdings rankings, we look at our endowment, and any number of things. There is a huge range of rankings.

The one I want to focus on today is the *U.S. News and World Report* as a ranking. For those institutions that do extremely well, we take a lot of pride in those rankings, and we look at them very seriously. When you're not at the top and aren't doing extraordinarily well, then you criticize the methodology, talk about them as being highly subjective, and say they don't really count. They do count. I think we all know that they count because they count with parents, they count with students, and they count with our academic peers. So whether we like them or not, they are with us, they are always going to be with us, and we have to be mindful of them.

I want to say a little bit about The Ohio State University and where we are in those national rankings. This is old news, but we rank #24. This puts us in the top 25 of public institutions in ranking. Certainly our goal is to keep moving up in that ranking, because most all of our Big Ten peers are above us in that ranking. Our goal is not to be where we are, but to keep moving up.

PRESIDENT'S REPORT (contd)

President Holbrook: (contd)

It is not the rankings that count, but it's the criteria that are used in the rankings that are measures of what we're doing with our students that are important. As a result of improving those criteria and improving our standings in those measures, our rankings are going to move up. It's not ranking for ranking's sake, but it's for what it says about where we're going in our institution.

I want to explore briefly about where we are today. Last week at a Foundation Board meeting, I mentioned where we are today and what it's going to take us to get into the top tier. We are in the top 25, but that doesn't mean we're in the top tier. We're in the second tier of universities that are ranked. We are not in the top 50; we are in the second group. I think we want to be among the top 50 universities and I think we can do it. So what does it take? What are the criteria? How do we stack up against those who are in the top tier? Let me give you some numbers.

First, let me say that we have done some things very well. It was very nice to see that we are ranked seventh in the nation in our First Year Experience. This is so important. What we do in the first year with these students tells us whether they're going to stay, how they're going to advance through our programs, and how much they're going to love us when they leave and remain in Jerry May's shop. That's very important to us. So our First Year Experience is absolutely critical. We rank #7 nationally and that's very good.

Our living/learning community is ranked eighteenth nationally. I think we really are a model for those kinds of experiences that personalize education for our students, and connects students very closely with faculty and with other people who are interested in the same areas. I think we can be very proud of that.

Let's then look at what it's going to take for us to join our other Big Ten colleagues -- Michigan, Northwestern, Illinois, Wisconsin, and Penn State -- in the ranks of top tier institutions. The average freshman retention rate is one of the criteria used. Eighty-four percent of our students are retained as freshman; up from 79 percent seven years ago. Most of the top ten institutions have their freshman retention rate in the 90th percentile.

In 2001 our graduation rate was 56 percent; the top tier institutions' graduation rates were in the 70s, 80s, and 90s. That's a stretch for us and it is going to be tough, because we are an urban institution. We do have many students who don't necessarily go straight through on their college education. The important thing is they get out of here, and they do graduate. That is going to be a tougher criterion to move up in, for us.

Percent of full-time faculty – 91 percent of our faculty are full-time. This is great, because it means we're preparing our students with people who are committed to our institution – not adjuncts, part-time, or other kinds of people who are only here for a little bit of the time. This is very good and this compares us very favorably with all top tier institutions.

SAT and ACT scores – that's a bit hard to compare with the 50 top tier schools, because all but three of them use the SAT scores. For those who do use ACT scores, our average scores range between 23 and 28; up again from 22.8 to 25.2. The three Big Ten schools – Illinois, Wisconsin, and Michigan – that use the ACT, their scores range are not 23 to 28, but 25 or 26 to 30. As we go to selective admissions for all quarters, I think we're going to see ACT scores rising as well. With more scholarship money, I think we would continue to see that rising.

PRESIDENT'S REPORT (contd)

President Holbrook: (contd)

Average alumni giving is another criterion and we are at 18 percent. The top tier giving ranges from 9 percent – UC-Ervine and UCSD, surprisingly – well below us, all the way to 64 percent, which is Princeton. Within that distribution the largest numbers are in the 20-40 percent range, so we're moving very well in that direction. I would wager if you looked at those top 50, many of those schools are going to be the private schools that have a long history of giving, not the public institutions.

We are doing very well. But we do want to move into the top tier and I want to give you a sense of what it is going to take to get us there. I also want to look at strategies for the implementation of the Academic Plan and focus today on one issue -- state support. I know you all think along with me, that it's absolutely critical that we sustain the level of state support that we have now and work to improve that level of support. We are a state institution, and let me tell you why I think the state needs to believe that we ought to be funded more.

We are in what's called "the new economy" and many of you may have read the document, "The New Economy Index." It's a very interesting document that talks about what the economy is today in this nation, what it takes to be in that economy, and it ranks states and metropolitan cities. It ranks Columbus among those metropolitan cities.

It describes the economy today as an economic transformation in which the goals are not more jobs -- which is what we've always measured the economy by -- but boosting our income and increasing it in better jobs. It is improving our position in a global economy. I was just delighted in the Academic Affairs Committee to hear where we are in the global economy, how we value a global experience for our students, and how we teach a number of languages that support language development for our students so that they do fit into this new economy.

The goal is to develop an infrastructure of innovation. Innovation is a word I've heard a lot on this campus. It's a word that describes our First Year Experience programs and our living/learning communities, and enhancing the quality of life and supporting industry clusters. Where are industry clusters located? Industry clusters are located around great universities. So all of the things that enhance the new economy are the things where we can play a role, front and center.

How do we stack up in the new economy index? We stack up among the 50 states as #30. I don't think that's where we want to be, and I don't think that's where the governor and our legislature want us to be. I think we want to keep going. California stands at the top and San Francisco stands at the top among the metropolitan areas. Columbus ranks as thirty-sixth among the top 50 cities, and here we have a great university in our midst.

So I think we have a great opportunity in this institution to really improve our position in the new economy. I'm hoping that we will have a chance to really talk about that on behalf of not just Ohio State, but on behalf of all of the state universities to really promote what it is that we can do.

A 1999 statistic showed that for every state dollar invested in The Ohio State University, we generated about \$3.55 – not a bad return on our investment. Right now if you look at just the state budget alone it is a 4-to-1 investment -- \$4 for every state dollar invested. But this doesn't tell the whole story. We also would need to look at the jobs that were created. We need to look at the companies that located here to be around a great university, the companies that

PRESIDENT'S REPORT (contd)

President Holbrook: (contd)

stayed here, and the companies that increased their numbers as a result of the university.

Of course, the most important measure of our success for the economy is the students that we produce who stay in this state and help develop that economy. Everyone knows the data of what the difference is between a salary for someone with a high school education, a college education, and a professional education. If you're talking about enhancing the tax base of this state, the educated workforce that comes out of our great universities in Ohio are the ones that are really going to make the difference.

I think we can make a huge difference to this state. I hope we will have a chance to convince the legislature that the new economy demands attention to its state universities. I think we need to do two things: 1) we obviously need to work to boost our rankings because they do reflect the quality of our academic improvement within this institution; and 2) we need to work to demonstrate what the value is of Ohio State University and all of our state universities, and that the value is unparalleled and deserves the trust and support of all of our constituencies.

Thank you very much.

--0--

THOMPSON LIBRARY RENOVATION PROPOSAL

Mr. Jerry A. May:

Joe Branin came to Ohio State nearly three years ago as director of the Libraries. Prior to his joining us, he was the director of the libraries at the State University of New York at Stony Brook. Before that he served a decade each at the University of Minnesota and University of Georgia -- a university that everyone's paying more attention to these days for some reason -- and he also served at Columbia University.

Joe's been actively involved with the introduction of information technology to our academic libraries. He has administered government grants dealing with the introduction of digital information to libraries, and he's published a variety of articles related to the library's changing role.

Right now Joe is leading a very new exciting effort called the "Knowledge Bank," which is an attempt to organize all of the new digital knowledge assets at the University, and you'll be hearing a lot more about that over time. Joe's mission includes overseeing 20 libraries on our campus. He was brought here with a special goal in mind, and it's the reason why you have the vice president for Development introducing this rather than the provost today. We have a very special partnership, because over the next five to eight years Joe is going to help us restore and renovate the William Oxley Thompson Memorial Library, known also as the Main Library.

We have one of the largest challenges ahead of us that any university has ever tackled. We're going to do a major renovation, it's going to cost a great deal of money, which Joe will talk to you about, and we're going to raise \$30 million in private support toward this particular project. There's barely been a university in the country that's ever tackled a project this large in terms of the fundraising goals.

THOMPSON LIBRARY RENOVATION PROPOSAL (contd)

Mr. May: (contd)

We're very excited, and I'm very thrilled to have Joe as my partner. He is a fine leader, and the donors and people associated with the library on the outside have been very impressed with his leadership. Ladies and gentlemen, I give you Dr. Joe Branin.

Dr. Joseph J. Branin: [PowerPoint Presentation]

Thank you very much, Jerry, and thank you for inviting me today to talk about this exciting project.

My job is to try to collect the record of achievement of scholars like Dr. Holbrook, poets like David Citino, and the results of these history grants. One of the challenges I have is where to put all this stuff that I'm collecting. I'd like to talk to you today about a very interesting and challenging building project that we have at the University.

We're attempting to restore and renovate the William Oxley Thompson Memorial Library at Ohio State. Some of the images that you see are all taken from architectural details in this grand old building. In 1998 a task force of the University faculty, appointed by the provost, issued a report which talked about the challenges to the Main Library, and one of their comments was the opportunities for the library are dazzling and real. I'd like to briefly give you a context for the Main Library, talk about its history, and then give you the scope and plan for the renovation of the Main Library.

We really have an excellent library system at Ohio State, and I'm very proud of it. You can see in the national rankings given out by the Association of Research Libraries in 1995 that we have progressed from 26th place to 19th place today, and we are ranked 12th among public universities.

We have a partnership with OhioLINK, which is unique in the country. OhioLINK is the best academic library consortium in the world and we try to work with other libraries in Ohio. As a result, we can leverage and get much better deals with our vendors. We provide our students and faculty with an array of on-line resources and print documents that are the best in the nation. We now have over 200 on-line databases, full-text articles to 25 major publishers, over 3,000 e-books, 46,000 art images, and daily satellite images of Ohio.

We have a superb library staff of about 400, who work very hard and are very service-oriented. We also have excellent general and special collections. Our print collection is approaching six million volumes, and we have special collections in all subject areas that are unique to our library.

One of the questions I'm sometimes asked is, "Does it make sense today to invest in bricks and mortar, and the traditional library?" I think the answer is a resounding "Yes!" We are embracing the new digital technology, but I don't think all information, all literature, and all knowledge transfer will take place over the computer. Place is still important and certainly important to a library. We find that paper is still the preferred medium of reading. I predict into the future, even though much information will be stored electronically, that we will still want to read it in a print medium, and print will not go away.

The social aspects of learning and research remain important – people want face-to-face service and instruction, and libraries serve as a symbolic and real center of knowledge and intellectual activity on campus and in the community.

THOMPSON LIBRARY RENOVATION PROPOSAL (contd)

Dr. Branin: (contd)

They are often grand spaces that inspire and pay tribute to scholarly achievement. I think it is a good investment to continue to have strong traditional libraries, as well as new digital libraries.

This slide shows the approach to the Main Library at Ohio State. I understand it's one of the most photographed sites on campus. Anyone who has gone to Ohio State knows this site – the William Oxley Thompson statue and the great classical Beaux-Arts façade of the Main Library limestone building at the head of the Oval.

The original library was built between 1910 and 1913, and was a beautiful building. In 1913 a student reported in the *Alumni Magazine*, "...to mount the broad main stairs was in itself an experience unreal. Then at length to see the quiet grandeur of the vast reference hall, high windows to the east, chaste whiteness of the walls, and the high curve of the vaulted arches overhead -- this was the climax of impressiveness." (*OSU Alumni Magazine*, January 1913, p.8.) Today, that stairwell is no longer in the library; it was taken out in the 1950s and replaced by a circular staircase that really does not fit the architecture of the building.

This slide shows the grand reading room in 1913. You can see that was the room that the student was talking about – two stories high, vaulted ceiling, the windows to your left overlook the Oval. It was one of the grand interior spaces at Ohio State. This is what it looks like today, and I think those two images really tell the story of what has happened to the 1913 building. It's lost its grandeur, it's been cut up, it's overcrowded, and it's rather shabby.

In 1951 a book tower was added to the 1913 building, and you see the tower behind the original building. It was designed to be a book storage facility; it was not a public area. You would request books and the staff would go into the stacks and retrieve the book and bring it out to you. It was not designed as a public area, although it is a public area today.

This is a cross section view of the stacks – you can see the narrow ceilings and an industrial-style addition. That's what the stacks look like – very few places to sit down; dark, narrow corridors. That was about as good as it got in the stacks; that's not a penitentiary, that is the Main Library stacks at Ohio State; and here is one of the reading carrels in the stacks.

In 1977 an addition was added behind the stacks. It's modern, useable space, but the architecture does not really fit very well with the rest of the building. If you're coming from the west this is the opposite direction from the Oval and you hit a dead end there. There's really no entrance to the library; it's not pedestrian-friendly.

We would like to really improve and make this grand library in this wonderful location a showplace on campus. We have plans for an eight-year project, ranging in cost anywhere from \$75 million to \$125 million. We divided the project into three phases: the first phase is the planning phase, which we've now completed, and I'll talk a little about that in a few minutes.

We're now moving into the detailed architectural phase. We're working on a memorandum of understanding and this month are issuing the request for proposals for the architect of record to come in and do the detailed design for us. If all goes well, and we still are very much on track, we will begin reconstruction in 2005 and finish no later than 2008.

THOMPSON LIBRARY RENOVATION PROPOSAL (contd)

Dr. Branin: (contd)

As Jerry said, this is a big project. One of the largest academic building projects undertaken by the University, so we're very concerned about advocacy and fundraising throughout the project. We have a major fundraising goal of \$30 million and we have an excellent development team in the library working with central Development. We are receiving strong community support and I'm pleased to say, to date, we have raised \$10 million toward our \$30 million goal. So we're well on our way toward reaching our goal. We hope to get state money through capital requests and we will be making capital requests in 2003, 2005, and 2007. I'm pleased to report that in the 2003 capital request, we were the #1 capital priority for the University.

To give you a little bit on the planning and study that we've been doing, we have completed an architectural feasibility study. We used the URS Corporation of Columbus and Shepley Bulfinch Richardson and Abbott of Boston, to look at our site, look at our building, look at our program needs, and give us some options for what we can do with the Main Library.

We were very concerned about the location of the Main Library. It is in the most historic site on campus -- the head of the Oval, next to Mirror Lake. It's very important for us to be sensitive to this landmark that we have.

This slide shows a cross section of the library. What we plan to do is the 1913 building -- that you see on your left -- will be very carefully restored and returned to the grandeur that it had in 1913. The atrium that connects the 1913 building to the book tower will be completely rethought and turned into a beautiful open space within the building. The book tower will undergo significant improvements, and the western façade -- the part that is opposite the Oval -- will be completely rethought, redone, and an entrance will be added. This will increase the foot traffic in the library -- people coming from west to east will enjoy coming through the library.

This slide shows what the main reading room might look like when it has been restored -- similar to what it looked like in 1913. This is what the atrium might look like. If you've been through the library, the atrium now is very dark and dreary; this would be open and bright.

The architects have given us a spectrum of plans ranging from a modest renovation, Scheme A, to the most radical renovation, Scheme D. Scheme A maintains the current architecture of the building, the current footprint of the building. It modifies the stacks slightly and it does add an entrance to the west. It would cost \$76 million.

Scheme B begins to make more architectural changes to the exterior of the building. It removes every other floor of the book tower to create more human space and the architects proposed adding small wings to the north and south.

Scheme C, which is similar to Scheme B, makes all those architectural changes and also allows us to consolidate some of our libraries and bring all of our special collections together in this library. We would close three branch libraries on campus and move those into this building. Scheme C is the model that the architects recommended to us, what the library feels would be the best, and this is the one that we're working on right now. The project cost would be \$98.6 million.

We also asked the architects to look at a more radical change, which would be Scheme D. We would maintain the 1913 building, but we would tear down the

THOMPSON LIBRARY RENOVATION PROPOSAL (contd)

Dr. Branin: (contd)

book tower and the 1977 addition, and build new modern space behind the 1913 building. We looked at that model and it came in at \$125 million. We also received a lot of community support for the book tower. The book tower of 1950 has become part of the campus landscape and a number of our constituents said, "Please don't tear that down!" So we're not pushing this model. We think Scheme C is a more realistic model, in terms of cost and meets all of our programmatic needs.

When we finish whatever option we decide, we're going to make sure that every inch of space is quality space in our Main Library. Our vision is for the Main Library to be a gateway to the universe of information services, both print and digital; and for it to be a research center on campus for all fields of knowledge, but particularly for the humanities and the liberal arts. We want it to be a showplace for the book arts and new information technology. We want it to be a destination and a gathering place on the Columbus campus for inviting and inspiring space for reading, learning, and research. Finally, we want it to be a place of celebration through its outstanding collections and services, and through its grand spaces for the record of scholarly achievement and the accumulation of knowledge.

We have a wonderful renovated stadium on campus and you heard plans this morning for the new Larkins Hall complex, so we're doing very well in the areas of athletics and recreational sports. This building is important for the intellectual record of the University, and we want to make it a destination and showplace on campus.

Thank you very much.

Mr. Patterson:

Thank you. Are there any questions or comments?

President Holbrook:

Joe, you briefly mentioned information technology in the Main Library. Are you going to have wireless areas and is it going to be wired so students can bring laptops?

Dr. Branin:

We're very interested in making it a library for the 21st century. As we go around the country looking at what other libraries are doing, we're finding that some of these grand old structures -- like the Butler Library at Columbia University or Harvard's Widener Library -- can be renovated. Instead of tearing those buildings down, we can renovate them, maintain the grand spaces, and bring new information technology into these buildings. There is a human element that finds these buildings so attractive and comfortable, and yet bring new information technology.

Certainly wireless is going to help us. We don't have to drill holes into the marble. We are now experimenting with wireless on campus and in our libraries. The law library is now wireless and parts of the Main Library and our science library are wireless. We plan to have the latest technology and we plan to create a lot of space for students to work individually and in groups with technology in this Main Library.

THOMPSON LIBRARY RENOVATION PROPOSAL (contd)

President Holbrook:

How about a coffee house?

Dr. Branin:

A coffee house is very important. We put a coffee café in the library two years ago, and it's very popular. We plan to maintain that and probably need to expand its space a bit. It's one of the most popular places on campus right now.

President Holbrook:

Good.

Mr. Patterson:

Joe, just an aside, how many libraries do we have around campus?

Dr. Branin:

We have approximately 20 library facilities around campus, and all of them are in very good shape. They're either new like our business library – it's brand new, state-of-the-art – or they're gems of historical libraries like the Orton Hall Library. If you haven't been to the Orton Hall Library, our Geology library, it's our oldest library on campus and is a beautiful library of very manageable dimensions. Only the Main Library is in bad physical shape, which we need to improve.

President Holbrook:

I would like to say how important it is that you've moved up in the rankings from 26th to 19th. I know what that means for a library these days and I want to commend The Ohio State University in helping you do that, because that's a big investment. Those rankings are based on holdings, as well as support. A library is a utility in my mind and every year it gets more and more expensive. People think because it's on-line it's cheap and it's going to decrease, but, in fact, it's not – it's ever more expensive. The fact that you've shown that great increase in the library position is really something Ohio State can be proud of.

Dr. Branin:

Thank you. I am very proud. I think it's the investment that Academic Affairs and the University have made in the library, and the great staff at Ohio State. I've worked at a number of universities and this is the best library staff I've ever worked with.

Mr. Patterson:

Thank you very much. Karen wondered what all of that white stuff was around the library when she saw one of the pictures. Solid rain!

--0--

CONSENT AGENDA

President Karen A. Holbrook:

We have nine resolutions on the Consent Agenda today --

CONSENT AGENDA (contd)

Mr. Patterson:

I would like to add a tenth resolution -- we need a motion and a second on the resolution for David Citino which we skipped previously.

President Holbrook:

Unless there are any objections, I would like to recommend the following resolutions to the Board, including the resolution naming David Citino, Poet Laureate of The Ohio State University:

AMENDMENTS TO THE *BYLAWS OF THE BOARD OF TRUSTEES*

Resolution No. 2003-40

Synopsis: Approval of amendments to the *Bylaws of the Board of Trustees* are recommended.

WHEREAS amendments to bylaw 3335-1-02 is recommended as follows:

Amended Bylaw

3335-1-02 Officers of the board.

(G) Secretary.

(1) Under the direction of the president and with the approval of the board of trustees, the secretary of the board of trustees shall:

- (a) Be the custodian of and responsible for the official books, records, and all transactions of the board, and such books, records, and transactions shall be open to public inspection in accordance with Ohio law;
- (b) Be the custodian of the university seal and cause its imprint to be placed whenever and wherever appropriate;
- (c) Sign, execute and deliver in the name of the university all deeds, mortgages, bonds, contracts and other instruments authorized by the board;
- (d) Keep the minutes of all meetings of the board and of committees of the board; and
- (e) See that all notices are duly given in accordance with the provisions of these rules.

(2) In addition, the secretary shall perform such other duties as from time to time may be assigned to him or her by the board or by the chair.

(3) The assistant secretary of the board shall be responsible for the management of all operational and administrative functions for the office of the board of trustees and in the absence of the secretary, or if a vacancy in the board secretary position exists, the assistant secretary shall perform the duties of the secretary of the board and all official actions taken by the assistant secretary shall be deemed authorized and approved by the board of trustees.

NOW THEREFORE

AMENDMENTS TO THE *BYLAWS OF THE BOARD OF TRUSTEES* (contd)

BE IT RESOLVED, That the foregoing amendments to the *Bylaws of the Board of Trustees* be adopted, effective immediately.

UNIFORM SELECTIVE ADMISSIONS FOR ALL QUARTERS

Resolution No. 2003-41

WHEREAS since 1986 the University has admitted fall quarter new freshmen using a competitive process designed to make certain that new students arrive well prepared to succeed in their academic work; and

WHEREAS this selective admissions process has resulted in ever better prepared classes of fall quarter freshmen, leading to higher levels of persistence to the second year and beyond, so that we expect to see increasing rates of graduation; and

WHEREAS the University has not applied the same selective admissions standards to students entering in winter or spring quarters, with the result that less well prepared entrants from these other quarters have displayed alarmingly low rates of persistence and graduation:

NOW THEREFORE

BE IT RESOLVED, That commencing with students entering the University for the academic year 2003-2004, uniform admissions standards, equivalent to those used for autumn quarter, be applied to students entering in any of the four academic quarters.

PERSONNEL ACTIONS

Resolution No. 2003-42

BE IT RESOLVED, That the personnel actions as recorded in the Personnel Budget Records of the University since the September 6, 2002 meeting of the Board, including the following Appointments, Reappointment of Chairperson/Director, Reappointment of Principal Administrative Official, a Leave of Absence Without Salary, and Emeritus Title as detailed in the University Budget be approved; and

BE IT FURTHER RESOLVED, That the Medical Staff Appointments/Reappointments approved September 17, 2002, by The James Cancer Hospital Board, be ratified; and

BE IT FURTHER RESOLVED, That Resolution 77-92 and the provisions of the Report of the Committee on Retirement and Insurance, calling for "Principal Administrative Officials" to be relieved of their administrative assignments at age 65, be waived to allow for a reappointment.

Appointments

Name: MARTHA A. BELURY
Title: Associate Professor (The Carol S. Kennedy Professorship in Human Nutrition)
College: Human Ecology
Term: October 1, 2002, through September 30, 2007
Present Position: Affiliate Associate Professor, Department of Pathobiology, University of Washington, and Associate Member, Department of Molecular Medicine, Norwest Hospital, Seattle, WA

PERSONNEL ACTIONS (contd)

Appointments (contd)

Name: LINDA L. HARLOW
Title: Interim Associate Provost for Honors and Scholars
Office: Academic Affairs
Effective: October 1, 2002
Present Positions: Associate Dean, College of Humanities, and Associate Professor,
Department of French and Italian

Name: KAREN A. HOLBROOK
Title: Professor
Departments/Division: Physiology and Cell Biology, and Internal Medicine/Dermatology
Effective: October 1, 2002
Concurrent Position: President, The Ohio State University

Name: THOMAS M. RIELAND
Title: General Manager of WOSU Stations
Office: University Relations
Effective: November 12, 2002
Present Position: Director and General Manager, Center for Public Television and Radio,
University of Alabama, Tuscaloosa, AL

Name: LARRY S. SCHLESINGER
Title: Professor (The Samuel Saslaw Professorship in Infectious Diseases)
Department/Division: Internal Medicine/Infectious Diseases
Term: October 1, 2002, through June 30, 2006

Reappointment of Chairperson/Director

July 1, 2002, through June 30, 2003

Human Development and Family Science
Ohio Supercomputer Center

Albert J. Davis
Russell M. Pitzer*

*Interim

Reappointment of Principal Administrative Official

FERDINAND A. GEIGER, Director of Athletics and Assistant Vice President for Student Affairs, effective July 1, 2004, through June 30, 2006, pursuant to rule 3335-3-17 of the Administrative Code.

Leave of Absence Without Salary

ROBERT L. ROMIG, Assistant Professor, School of Natural Resources (OARDC), effective October 1, 2002, through September 30, 2003, to accept a position with the Ohio Forestry Association.

Emeritus Title

JEAN T. SNOOK, Department of Human Nutrition, with the title Professor Emeritus, effective October 1, 2002.

PERSONNEL ACTIONS (contd)

Medical Staff Appointments (The Arthur G. James Cancer Hospital and Richard J. Solove Research Institute)

August/September 2002

Initial Appointments – Faculty

William T. Abraham, M.D., Internal Medicine, Cardiology, Associate Attending
Michael A. Baird, M.D., Internal Medicine, Digestive Diseases, Clinical Assistant Professor, Associate Attending
Tanios Bekaii- Saab, M.D., Internal Medicine, Hematology/Oncology, Assistant Professor, Attending
Gary Bos, M.D., Orthopaedics, Professor, Attending
James R. Bruno, D.M.D., M.D., Surgery, Plastic Surgery, Clinical Assistant Professor, Associate Attending
Lisa Dunn-Albanese, M.D., Obstetrics and Gynecology, Clinical Assistant Professor, Associate Attending
Jill Fitch, M.D., Pediatric Critical Care, Clinical Attending
Lisa S. Gaines, D.O., Anesthesiology, Clinical Assistant Professor, Associate Attending
Roberta E. Galford, M.D., Anesthesiology, Clinical Assistant Professor, Associate Attending
Bachar Hachwa, M.D., Anesthesiology, Clinical Assistant Professor, Associate Attending
Djavid Hadian, M.D., Internal Medicine, Cardiology, Assistant Professor, Associate Attending
Catherine R. Lucey, M.D., Internal Medicine, General Medicine, Associate Professor, Associate Attending
David N. Quinn, M.D., Internal Medicine, Digestive Diseases, Clinical Assistant Professor, Associate Attending
Robert J. Ragosin, M.D., Radiology, Associate Professor, Associate Attending
Joel H. Saltz, M.D., Ph.D., Pathology, Professor, Associate Attending
Bivik Shah, M.D., Surgery, Plastic Surgery (Previously on medical staff; did not reappoint on time due to incomplete application)
Ganesh B. Shidham, M.D., Internal Medicine, Nephrology, Assistant Professor-Clinical, Associate Attending
Michael Stanek, M.D., Internal Medicine, Hematology/Oncology (Previously on medical staff; did not reappoint on time due to suspended license)
Eric Ward, M.D., Surgery, Urology (Previously on medical staff; did not reappoint on time due to incomplete application)
Christopher Yerington, M.D., Anesthesiology, Clinical Assistant Professor, Associate Attending
Yiqing Xu, M.D., Ph.D., Internal Medicine, Hematology/Oncology, Assistant Professor, Attending

Initial Appointments – Community

Najeeb Ahmed, Internal Medicine, General Medicine, Community Associate
Ananth Annamraju, M.D., Surgery, Urology, Community Associate
Jerald S. Dudley, M.D., Internal Medicine, General Medicine, Community Associate
Thomas Keeling, M.D., Internal Medicine, Infectious Diseases, Community Associate based at University Hospitals/East
Y. Charley Imamura, M.D., Internal Medicine, General Medicine, Community Associate
Vlada Wally Mardovin, Surgery, Urology
Gary C. Reid, M.D., Obstetrics and Gynecology, Community Associate based at Riverside Methodist Hospital
Alper Sarihan, D.O., Family Practice, Community Associate
Salvador B. Trinidad, M.D., Radiology, Community Associate

Initial Appointments – Advanced Practice Nursing

Kelly McDannald Slavens, R.N., C.N.P.

PERSONNEL ACTIONS (contd)

Medical Staff Appointments (The Arthur G. James Cancer Hospital and Richard J. Solove Research Institute) (contd)

August/September 2002 (contd)

Provisional to Full Appointment – Faculty

Brian Biernat, M.D., Internal Medicine, Dermatology, Associate Attending
M. Farid Edwards, M.D., Anesthesiology, Associate Attending
Gregory E. Guy, M.D., Radiology, Associate Attending
John E. Hohmann, M.D., Anesthesiology, Clinical Attending
Sherman Katz, M.D., Surgery, General Surgery, Associate Attending
John S. Rogoski, D.O., Anesthesiology, Associate Attending
G. Todd Schulte, M.D., Anesthesiology, Associate Attending

Additional Privileges Requested

William A. Garringer, M.D., Community Associate, Family Medicine Privileges
Scott K. Kellogg, D.O., Community Associate, Family Medicine Privileges

Extension of Appointment

Patrick Ross, Jr., M.D., Ph.D., Surgery, Cardiothoracic Surgery, 9/30/02 – 06/30/04

RESOLUTION IN MEMORIAM

Resolution No. 2003-43

Synopsis: Approval of a Resolution in Memoriam is proposed.

RESOLVED, That the Board adopt the following Resolution in Memoriam and that the President be requested to convey a copy to the family of the deceased.

Larry J. Peterson

The Board of Trustees of The Ohio State University expresses its sorrow upon the death on August 7, 2002, of Dr. Larry J. Peterson, clinical professor in the College of Dentistry (Oral and Maxillofacial Surgery).

Dr. Peterson, a native of Winfield, Kansas, graduated from the University of Kansas with a Bachelor of Science degree in 1964. He then entered The University of Missouri, Kansas City School of Dentistry, earning the Doctor of Dental Surgery degree, cum laude, in 1968. Upon graduation, he was selected as an oral surgery resident at the Georgetown University School of Dentistry, receiving his certificate and a Master of Science degree in 1971. He then joined the faculty of the Medical College of Georgia School of Dentistry as an assistant professor of oral surgery and in 1974 was promoted to the rank of associate professor. In 1975 he joined the faculty of the University of Connecticut School of Dental Medicine. He was appointed program director for oral and maxillofacial surgery in 1980 and was promoted the following year to the rank of professor. In 1982 he was appointed professor and director of Oral and Maxillofacial Surgery at The Ohio State University and to the active staffs of The Ohio State University Hospitals and Children's Hospital. In 1998 he resigned his directorship to devote his time to teaching and, two years later, resigned his full-time appointment. He maintained a relationship with the College of Dentistry as a part-time instructor until his death.

RESOLUTION IN MEMORIAM (contd)

Larry J. Peterson (contd)

He is remembered by his former students and faculty colleagues as an outstanding teacher. In 1996 the American Association of Oral and Maxillofacial Surgery selected him for the Robert B. Osborn Outstanding Educator Award, and in 1998 his faculty colleagues awarded him the Wendell D. Postle Teaching Award. In March 2000 the Larry J. Peterson Young Educators Award Fund was established to recognize a young faculty member in the College of Dentistry who demonstrated unusual enthusiasm for teaching.

Dr. Peterson was elected to membership in Omicron Kappa Upsilon dental honor society, the American College of Dentists, and the International College of Dentists. He was a fellow of the American Dental Society of Anesthesiology and a Diplomate of the American Board of Oral and Maxillofacial Surgery. He was also a member of numerous professional societies, including the American Dental Association, the American Association of Oral and Maxillofacial Surgery, the American Association of Dental Schools, and the International Association of Dental Research.

Dr. Peterson was an active researcher who pursued a wide range of funded studies in the field of oral surgery, including pioneer work on oral implants. A scholar, he served as editor-in-chief of the prestigious journal, *Oral Surgery, Oral Pathology, Oral Radiology, and Endodontics* from 1993 until his death.

On behalf of the University community, the Board of Trustees expresses to the family of Dr. Larry J. Peterson its deepest sympathy and sense of understanding of their loss. It was directed that this resolution be inscribed upon the minutes of the Board of Trustees and that a copy be tendered to his family as an expression of the Board's heartfelt sympathy.

REPORT OF RESEARCH CONTRACTS AND GRANTS

Resolution No. 2003-44

Synopsis: The report on research and other sponsored program contracts and grants and the summary for August 2002 is presented for Board acceptance.

WHEREAS monies are solicited and received on behalf of the University from governmental, industrial, and other agencies in support of research, instructional activities, and service; and

WHEREAS such monies are received through The Ohio State University Research Foundation:

NOW THEREFORE

BE IT RESOLVED, That the research agreement between The Ohio State University and The Ohio State University Research Foundation for the contracts and grants reported herein during the month of August 2002 be approved.

REPORT ON UNIVERSITY DEVELOPMENT

Resolution No. 2003-45

Synopsis: The report on the receipt of gifts and the summary for August 2002 are presented for Board acceptance.

WHEREAS monies are solicited and received on behalf of the University from alumni, industry, and various individuals in support of research, instructional activities, and service; and

WHEREAS such gifts are received through The Ohio State University Development Fund and The Ohio State University Foundation; and

REPORT ON UNIVERSITY DEVELOPMENT (contd)

WHEREAS this report includes the establishment of four (4) new named endowed funds, the amendment of one (1) named endowed professorship, and the amendment of seven (7) named endowed funds:

NOW THEREFORE

BE IT RESOLVED, That the acceptance of the report from The Ohio State University Development Fund and The Ohio State University Foundation during the month of August 2002 be approved.

TOTAL UNIVERSITY PRIVATE SUPPORT

July through August
2001 Compared to 2002

GIFT RECEIPTS BY DONOR TYPE

	Dollars July through August		
	<u>2001</u>	<u>2002</u>	<u>%Change</u>
Individuals:			
Alumni (Current Giving)	\$3,031,234	\$5,222,996	72
Alumni (From Bequests)	<u>1,223,946</u>	<u>972,088</u>	(21)
Alumni Total	\$4,255,180	\$6,195,084	46
Non-Alumni (Current Giving)	\$1,790,511	\$2,890,725	57
Non-Alumni (From Bequests)	<u>877,043</u>	<u>1,762,492</u>	101
Non-Alumni Total	\$2,667,554	\$4,572,217	71
Individual Total	\$6,922,734	\$10,767,301	56 ^A
Corporations/Corp/Foundation	\$7,018,235	\$6,573,055	(6)
Private Foundations	\$2,280,388	\$1,117,205	(51) ^B
Associations and Other Organizations	<u>\$600,728</u>	<u>\$457,396</u>	(24) ^C
Total	\$16,822,085	\$18,914,957	12

NOTES

- A Individual giving is up 56% largely due to the fact that gifts of \$10,000 or more are up 94% (65 gifts for \$4.7 million last year; 78 gifts for \$9.1 million this year).
- B Foundation giving at the \$10,000 or more level is down 55% for the first two months of the fiscal year (\$1.0 million from 21 gifts this year; \$2.2 million from 29 gifts last year).
- C Gifts at the \$10,000 or more level from other organizations or associations are down 35% for July-August compared with the same period last year (12 gifts for \$321,596 last year; 11 gifts for \$209,520 this year).

REPORT ON UNIVERSITY DEVELOPMENT (contd)

TOTAL UNIVERSITY PRIVATE SUPPORT (contd)

July from August
2001 Compared to 2002

GIFT RECEIPTS BY PURPOSE

	Dollars July through August		
	<u>2001</u>	<u>2002</u>	<u>% Change</u>
Gift Receipts to Current Use and Endowment Funds:			
Buildings/Equipment	\$3,282,934	\$2,894,973	(12)
Faculty Support	\$347,938	\$2,615,160	652
Program Support	\$10,202,510	\$8,788,930	(14)
Student Financial Aid	\$2,234,512	\$3,305,263	48
Annual Funds-Colleges/Departments	\$655,268	\$1,207,433	84
Annual Funds-University	<u>\$98,923</u>	<u>\$103,198</u>	4
Total	\$16,822,085	\$18,914,957	12

GIFT ADDITIONS TO ENDOWMENT

Dollars
July through August

<u>2001</u>	<u>2002</u>	<u>% Change</u>
\$4,013,497	\$6,890,350	72

REPORT ON UNIVERSITY DEVELOPMENT (contd)

THE OHIO STATE UNIVERSITY DEVELOPMENT FUND

Change in Name and Description of Named Endowed Professorship

From: The William Ray Flesher Professorship in Educational Administration Fund
To: The William Ray and Marie Adamson Flesher Professorship
in Educational Administration

Change in Description of Named Endowed Funds

The Ted and Lois Cyphert Distinguished Professorship Fund in Teacher Education
TBDBITL Scholarship Fund

Change in Name and Description of Named Endowed Funds

From: Thomas A. and John E. Hamrick Pickaway County Scholarship Fund
To: Thomas A. and John E. Hamrick Memorial Scholarship Fund for Pickaway County

From: Secrest Arboretum Director's Fund
To: The Secrest Arboretum Founders Endowment Fund

THE OHIO STATE UNIVERSITY FOUNDATION

	<u>Previous Gifts</u>	<u>Current Gifts</u>	<u>Total Gifts</u>
<u>Establishment of Named Endowed Funds</u>			
The Ralph Irwin and Julia Winter Cohen Critical Difference for Women Re-Entry Scholarship Fund (Used to provide scholarships for women to re-enter the educational process; provided by gifts from the A.B., Dolly and Ralph Cohen Foundation as designated by Susan Winter Ward and Marilyn Winter-Tamkin in memory of Ralph Irwin and Julia Winter Cohen)		\$851,000.00	\$851,000.00
The Frank S. Meszaros Memorial Fund (Used to provide financial aid scholarships to incoming freshmen who have shown an interest in Hungarian culture and the topic of religion; provided by gifts from Gary V. Meszaros and Douglas J. Meszaros)		\$25,000.00	\$25,000.00
The Manuel Tzagournis M.D. and Madeline Tzagournis Medical Research Fund (Used to support research conducted in the Medical Research Facility; provided by gifts from Manuel Tzagournis, Madeline Tzagournis and other family members) provided by an estate gift from Marjorie Weaver)		\$25,000.00	\$25,000.00

REPORT ON UNIVERSITY DEVELOPMENT (contd)

THE OHIO STATE UNIVERSITY FOUNDATION (contd)

	<u>Previous Gifts</u>	<u>Current Gifts</u>	<u>Total Gifts</u>
<u>Establishment of Named Endowed Funds (contd)</u>			
The Gene Wittmeyer Vegetable Scholarship Endowment Fund (Used to support scholarships for crop science majors in the College of Food, Agricultural, and Environmental Sciences; provided by gifts from the Ohio Vegetable and Potato Grower's Association, alumni and friends honoring		\$25,000.00	\$25,000.00
<u>Change in Description of Named Endowed Fund</u>			
The John and Linda Mercer Scholarship Fund			
<u>Change in Name and Description of Named Endowed Fund</u>			
From: The Medical Research Facility Grant Fund			
To: The Huntington National Bank Medical Research Fund			
Total		\$926,000.00	\$926,000.00

THE OHIO STATE UNIVERSITY DEVELOPMENT FUND

Change in Name and Description of Named Endowed Professorship

The William Ray and Marie Adamson Flesher Professorship
in Educational Administration

The William Ray Flesher Professorship in Educational Administration Fund was established June 10, 1982 by the Board of Trustees of The Ohio State University with a bequest from Marie Adamson Flesher (M.A., 1935; Ph.D., 1951) and William Ray Flesher (M.A., 1935; Ph.D., 1942) of Little Rock, Arkansas. The name was changed to The William Ray Flesher Professorship in Educational Administration on June 26, 1984, with the name and description further revised on October 4, 2002.

All gifts are to be invested in the University's Permanent Endowment Fund, under the rules and regulations adopted by the Board of Trustees of The Ohio State University, with the right to invest and reinvest as occasion dictates.

The annual income shall be used to provide support for the work of a distinguished scholar in the field of educational administration. Appointment to the Flesher Professorship will be recommended by the dean of the College of Education to the executive vice president and provost and approved by the Board of Trustees.

Ten percent of the annual interest shall automatically revert to the fund principal annually.

It is the desire of the donors that this fund should benefit the University in perpetuity. If the need for this fund should cease to exist or so diminish as to provide unused income, then another use shall be designated by the Board of Trustees in consultation with the appropriate program administrative officer of the university who is then directly responsible for educational administration in order to carry out the desire of the donors.

REPORT ON UNIVERSITY DEVELOPMENT (contd)

THE OHIO STATE UNIVERSITY DEVELOPMENT FUND (contd)

Change in Description of Named Endowed Funds

The Ted and Lois Cyphert Distinguished Professorship Fund in Teacher Education

The Ted and Lois Cyphert Distinguished Professorship Fund in Teacher Education was established February 4, 1994, by the Board of Trustees of The Ohio State University with gifts from Frederick R. "Ted" and Lois Cyphert, in recognition of their commitment to teacher education; in recognition of Ted Cyphert's years of service on the faculty, and as dean of the College of Education. It is meant to maintain the strong tradition fostered by persons like Earl Anderson, L.O. Andrews, Donald Cottrell, Donald Cruickshank, Ted Cyphert, Karl Openshaw, and Nancy Zimpher who have striven at The Ohio State University to prepare generalist teacher educators. The description was revised on October 4, 2002.

All gifts are to be invested in the University's Permanent Endowment Fund, under the rules and regulations adopted by the Board of Trustees of The Ohio State University, with the right to invest and reinvest as occasion dictates.

The annual income shall be used to support the research, teaching and management activities of a distinguished professor in the field of general/generic teacher education in the College of Education. Generic teacher education is defined as the knowledge, skills, and values needed by all teachers and all teacher educators, as these differ from pedagogical knowledge that is subject-field or age-level specific. The primary duties of the distinguished professor will be directing the studies of doctoral students majoring in generic pre-service and/or in-service teacher education who wish to be generalist teacher educators. Duties will also include oversight of general pedagogy classes for practicing and/or future teachers, supervising field and clinical experiences and conducting research and publishing in this field.

Appointment to the professorship should be made by the dean of the College of Education in consultation with faculty. An annual report of the activities of the distinguished professor shall be given to the faculty of the College of Education.

If generic teacher education should no longer be a part of the curriculum of The Ohio State University, the income from this fund will be used to support the faculty member in the College of Education who most closely personifies the objectives of the donors as delineated above.

Until the fund principal reaches \$500,000, interest shall automatically revert to principal annually. After the fund reaches \$500,000, 10 percent of the annual interest shall automatically revert to the fund principal each year.

It is the desire of the donors that this fund should benefit the University in perpetuity. If the need for this fund should cease to exist or so diminish as to provide unused income, then another use shall be designated by the Board of Trustees in consultation with the dean of the College of Education in order to carry out the desire of the donors.

TBDBITL Scholarship Fund

The TBDBITL Scholarship Fund was established April 6, 1984, by the Board of Trustees of The Ohio State University with gifts from the TBDBITL Alumni Club. The description was revised on October 4, 2002.

All gifts are to be invested in the University's Permanent Endowment Fund, under the rules and regulations adopted by the Board of Trustees of The Ohio State University, with the right to invest and reinvest as occasion dictates.

REPORT ON UNIVERSITY DEVELOPMENT (contd)

THE OHIO STATE UNIVERSITY DEVELOPMENT FUND (contd)

Change in Description of Named Endowed Funds (contd)

TBDBITL Scholarship Fund (contd)

The annual income shall be awarded as scholarship(s) to one or more deserving students by the School of Music to encourage participation in The Ohio State University Marching Band. Selection of the recipient(s) is to be made by established procedures within the school, with final approval by the director of the School of Music who will also approve requisitions for payment. Scholarships will be awarded in consultation with the University Committee on Student Financial Aid.

One of the awards will be designated to the student chosen to be the head drum major and will provide full in-state tuition to that individual. This individual must meet the following criteria in order to receive and continue to receive the full scholarship. The student must be enrolled as a full-time student at The Ohio State University and must be academically eligible – not on academic probation. If the obligations of the drum major are not met during the preceding quarter, the next tuition installment will not be granted for the upcoming quarter. These obligations will be determined by the director of the Marching Band, the advisor of the Drum Major Club, and the coach of the Drum Major Club. Stated obligations must be kept on file with the Marching Band staff at the Joan Zieg Steinbrenner Band Center at Ohio Stadium and will be monitored by a committee each quarter to ensure that they are fulfilled prior to disbursement of the funds. The committee members must consist of the following people: the director of the Marching Band, the advisor of the Drum Major Club, the coach of the Drum Major Club, the president of TBDBITL Alumni Club, and the secretary of the Script Ohio Club.

It is the desire of the donors that this fund should benefit the University in perpetuity. If the need for this fund should cease to exist or so diminish as to provide unused income, then another use shall be designated by the Board of Trustees in consultation with the appropriate college dean, school director, department chairperson, or program administrative officer in order to carry out the desire of the donors.

Change in Name and Description of Named Endowed Funds

Thomas A. and John E. Hamrick Memorial Scholarship Fund for Pickaway County

The Thomas A. and John E. Hamrick Pickaway County Scholarship Fund was established December 5, 1986, by the Board of Trustees of The Ohio State University with gifts from George H. Hamrick (B.S., 1951; M.S., 1959), chair of the Pickaway County Office of the Ohio State University Extension from 1957 to 1984, and his wife, Dorothy (B.S., 1947), in memory of their sons. The name and description were revised on October 4, 2002.

All gifts are to be invested in the University's Permanent Endowment Fund, under the rules and regulations adopted by the Board of Trustees of The Ohio State University, with the right to invest and reinvest as occasion dictates.

The annual income from this fund shall be used to provide one or more scholarships for undergraduate students enrolled in any degree program on the Columbus campus in the College of Food, Agricultural, and Environmental Sciences or the College of Human Ecology or their successors. Criteria for selection shall include outstanding scholastic achievement and leadership potential demonstrated through extracurricular activities. Preference is for students beyond their first year of studies, with financial need, who are from Pickaway County. Second preference is for students from Gallia or Ross Counties. The University Committee on Student Financial Aid will make selections in consultation with the vice president for Agricultural Administration and University Outreach and executive dean for Food, Agricultural, and Environmental Sciences, and the dean of the College of Human Ecology.

REPORT ON UNIVERSITY DEVELOPMENT (contd)

THE OHIO STATE UNIVERSITY DEVELOPMENT FUND (contd)

Change in Name and Description of Named Endowed Funds (contd)

Thomas A. and John E. Hamrick Memorial Scholarship Fund for Pickaway County (contd)

It is the desire of the donors that this fund should benefit the University in perpetuity. If the need for this fund should cease to exist or so diminish as to provide unused income, then another use shall be designated by the Board of Trustees in consultation with the vice president for Agricultural Administration and University Outreach and executive dean for Food, Agricultural, and Environmental Sciences, and the dean of the College of Human Ecology in order to carry out the desire of the donors.

The Secrest Arboretum Founders Endowment Fund

The Secrest Arboretum Director's Fund was established February 5, 1999, by the Board of Trustees of The Ohio State University through existing OARDC funds. The name and description were revised on October 4, 2002.

All gifts are to be invested in the University's Permanent Endowment Fund, under the rules and regulations adopted by the Board of Trustees of The Ohio State University, with the right to invest and reinvest as occasion dictates.

The annual income shall be used to advance the research, education and natural beauty of the Secrest Arboretum at the Ohio Agricultural Research and Development Center in Wooster, Ohio. The fund shall be used for, but not limited to, the purchase or support of plant and interpretive signage, staffing, grounds and garden maintenance, educational programming, and the propagation of new cultivars. Unused funds shall be reinvested in the principal.

Use of the annual income shall be directed by the curator of the Secrest Arboretum in consultation with the director of the Ohio Agricultural Research and Development Center and the Secrest Arboretum Board of Governors.

It is the desire of the donors that this fund should benefit the University in perpetuity. If the need for this fund should cease to exist or so diminish as to provide unused income, then another use shall be designated by the Board of Trustees in consultation with the director of the Ohio Agricultural Research and Development Center and the curator of the Secrest Arboretum in order to carry out the desire of the donors.

THE OHIO STATE UNIVERSITY FOUNDATION

Establishment of Named Endowed Funds

The Ralph Irwin and Julia Winter Cohen Critical Difference for Women
Re-Entry Scholarship Fund

The Ralph Irwin and Julia Winter Cohen Critical Difference for Women Re-Entry Scholarship Fund was established October 4, 2002, in accordance with the guidelines approved by the Board of Directors of The Ohio State University Foundation, with gifts from the A.B., Dolly and Ralph Cohen Foundation as designated by Susan Winter Ward and Marilyn Winter-Tamkin to preserve the memory of their mother and stepfather, Ralph Irwin and Julia Winter Cohen.

All gifts are to be invested by the Foundation, under the rules and regulations adopted by the Foundation's Board of Directors, with the right to invest and reinvest as occasion dictates.

REPORT ON UNIVERSITY DEVELOPMENT (contd)

THE OHIO STATE UNIVERSITY FOUNDATION (contd)

Establishment of Named Endowed Funds (contd)

The Ralph Irwin and Julia Winter Cohen Critical Difference for Women
Re-Entry Scholarship Fund (contd)

The annual income shall be used to provide scholarships for women at the undergraduate, graduate, and professional level who have interrupted their education to meet other responsibilities and are in need of financial support to re-enter the educational process, with preference given to women who have children at home and with further preference for those who are interested in careers in education. Recipients will be selected in consultation with the Critical Difference for Women Scholarship Committee and the University Committee on Student Financial Aid.

It is the desire of the donors that this fund should benefit the University in perpetuity. If the need for this fund should cease to exist or so diminish as to provide unused income, then another use shall be designated by the Foundation Board in consultation with the appropriate program administrative officer in order to carry out the desire of the donors.

\$851,000.00

The Frank S. Meszaros Memorial Fund

The Frank S. Meszaros Memorial Fund was established October 4, 2002, in accordance with the guidelines approved by the Board of Directors of The Ohio State University Foundation, with gifts from Gary V. Meszaros (B.S.Bus.Adm., 1972) of Toledo, Ohio, and Douglas J. Meszaros (B.I.E., 1971; M.B.A., 1979) of Columbus, Ohio.

All gifts are to be invested by the Foundation, under the rules and regulations adopted by the Foundation's Board of Directors, with the right to invest and reinvest as occasion dictates.

The annual income shall be used to provide financial aid scholarships to incoming freshmen, with a preference to students who have shown a demonstrated interest in Hungarian culture and in the topic of religion. The scholarships will be awarded by the Office of Student Financial Aid and are non-renewable.

It is the desire of the donors that this fund should benefit the University and its students in perpetuity. If the need for this fund should cease to exist or so diminish as to provide unused income, then another use shall be designated by the Foundation Board in consultation with the vice president for University Development and the director of Student Financial Aid in order to carry out the desire of the donors.

\$25,000.00

The Manuel Tzagournis M.D. and Madeline Tzagournis Medical Research Fund

The Manuel Tzagournis M.D. and Madeline Tzagournis Medical Research Fund was established on October 4, 2002, in accordance with the guidelines approved by the Board of Directors of The Ohio State University Foundation with gifts to the Foundation from Manuel Tzagournis, M.D. (B.S., 1956; M.D. *cum laude*, 1960; M.S., 1967) and Madeline Tzagournis (B.S., 1957) of Columbus, Ohio, and from other family members.

All gifts are to be invested by the Foundation, under the rules and regulations adopted by the Foundation Board of Directors with the right to invest and reinvest as occasion dictates.

REPORT ON UNIVERSITY DEVELOPMENT (contd)

THE OHIO STATE UNIVERSITY FOUNDATION (contd)

Establishment of Named Endowed Funds (contd)

The Manuel Tzagournis M.D. and Madeline Tzagournis Medical Research Fund (contd)

The annual income from this fund, and other similar funds under the Medical Research Endowment Trust, shall be used to support researchers conducting research in the Medical Research Facility, with selection made through a grant application process. Researchers may apply for one-year funding grants, which are not limited to senior faculty, through the vice dean for research in the College of Medicine and Public Health. Selection shall be made by the vice dean for Research in the College of Medicine and Public Health in consultation with the senior vice president for Health Sciences and dean of the College of Medicine and Public Health. The grants may be used for, but not limited to, supplies, equipment, salaries for research personnel, and activities required for quality medical research.

It is the desire of the donors that this fund should benefit the University in perpetuity. If the need for this fund should cease to exist or so diminish as to provide unused income, then another use shall be designated by the Board of Trustees in consultation with the vice dean for Research in the College of Medicine and Public Health and the senior vice president for Health Sciences and dean of the College of Medicine and Public Health in order to carry out the desire of the donors.

\$25,000.00

The Gene Wittmeyer Vegetable Scholarship Endowment Fund

The Gene Wittmeyer Vegetable Scholarship Endowment Fund was established on October 4, 2002, in accordance with the guidelines approved by the Board of Directors of The Ohio State University Foundation with gifts from the Ohio Vegetable and Potato Grower's Association, and alumni and friends honoring Professor Emeritus Gene Wittmeyer (B.S.Agr., 1946), who joined The Ohio State University in 1950.

All gifts are to be invested by the Foundation, under the rules and regulations adopted by the Foundation's Board of Directors, with the right to invest and reinvest as occasion dictates.

The annual income shall be used to support scholarship(s) for an undergraduate or graduate student enrolled in the College of Food, Agricultural, and Environmental Sciences. First preference will be given to students in good academic standing with an interest in vegetable crops (crop science major) in the Department of Horticulture and Crop Science and/or students demonstrating association or involvement with the Ohio vegetable industry.

The student recipient(s) shall be selected by the Scholarship Selection Committee of the Department of Horticulture and Crop Science, in consultation with the department chairperson, the Office of Student Financial Aid, and the Scholarship Committee of the Ohio Vegetable and Potato Grower's Association.

It is the desire of the donors that this fund should benefit the University in perpetuity. If the need for this fund should cease to exist or so diminish as to provide unused income, then another use shall be designated by the Foundation Board in consultation with the vice president for Agricultural Administration and University Outreach, and executive dean for Food, Agricultural and Environmental Sciences and the chairperson of the Department of Horticulture and Crop Science or their successor, or appropriate administrative officer, or their successor, in order to carry out the desire of the donors.

\$25,000.00

REPORT ON UNIVERSITY DEVELOPMENT (contd)

THE OHIO STATE UNIVERSITY FOUNDATION (contd)

Change in Description of Named Endowed Fund

The John and Linda Mercer Scholarship Fund

The John and Linda Mercer Scholarship Fund was established December 6, 2001, in accordance with the guidelines approved by the Board of Directors of The Ohio State University Foundation, with gifts from John Mercer (B.Agr.E., 1952; B.S.Ed., 1962) and Linda Mercer (B.S.Ed., 1957; M.A., 1965; Ph.D., 1974) of Columbus, Ohio. The description was revised on October 4, 2002.

All gifts are to be invested by the Foundation, under the rules and regulations adopted by the Foundation's Board of Directors, with the right to invest and reinvest as occasion dictates.

The annual income shall be used to support a student(s) of the College of Education and/or the School of Music who has an interest in teaching in the public school system, with first preference given to a student(s) pursuing a teaching career(s) in physical science or music. The annual income shall alternate between the College of Education and the School of Music each year in order to provide a single scholarship until the annual income exceeds \$2,000.00, at which time the annual income shall be divided evenly between the College of Education and the School of Music. The scholarship will be awarded in consultation with the University Committee on Student Financial Aid.

It is the desire of the donors that this fund should benefit the University in perpetuity. If the need for this fund should cease to exist or so diminish as to provide unused income, then another use shall be designated by the Foundation Board in consultation with the dean of the College of Education and the director of the School of Music in order to carry out the desire of the donors.

Change in Name and Description of Named Endowed Fund

The Huntington National Bank Medical Research Fund

The Medical Research Facility Grant Fund was established on October 3, 1997, in accordance with the guidelines approved by the Board of Directors of The Ohio State University Foundation with gifts from an anonymous donor to establish the fund in honor of Dr. Manuel Tzagournis, former vice president of Health Sciences and dean of the College of Medicine and Public Health. Additional gifts were made to this fund from the Huntington National Bank and/or its Foundation on behalf of the Huntington National Bank of Columbus, Ohio. The name and description were revised on October 4, 2002.

All gifts are to be invested by the Foundation, under the rules and regulations adopted by the Foundation Board of Directors with the right to invest and reinvest as occasion dictates.

The annual income from this fund, and other similar funds under the Manuel Tzagournis Medical Research Endowment Trust, shall be used to support researchers conducting research at the Medical Center, mainly in the Manuel Tzagournis Medical Research Facility, with selection made through a grant application process. Researchers may apply for one-year funding grants, which are not limited to senior faculty, through the vice dean for Research in the College of Medicine and Public Health. Selection shall be made by the vice dean for Research in the College of Medicine and Public Health in consultation with the senior vice president for Health Sciences and dean of the College of Medicine and Public Health. The grants may be used for, but not limited to: supplies, equipment, salaries for research personnel, and activities required for quality medical research.

REPORT ON UNIVERSITY DEVELOPMENT (contd)

THE OHIO STATE UNIVERSITY FOUNDATION (contd)

Change in Name and Description of Named Endowed Fund (contd)

The Huntington National Bank Medical Research Fund (contd)

It is the desire of the donors that this fund should benefit the University in perpetuity. If the need for this fund should cease to exist or so diminish as to provide unused income, then another use shall be designated by the Board of Trustees in consultation with the vice dean for Research and the senior vice president for Health Sciences and dean of the College of Medicine and Public Health in order to carry out the desire of the donors.

WAIVERS OF COMPETITIVE BIDDING REQUIREMENTS

Resolution No. 2003-46

APRIL – JUNE 2002

Synopsis: Acceptance of the quarterly report on waivers of competitive bidding requirements is proposed.

WHEREAS the Purchasing Policy of The Ohio State University adopted by the Board of Trustees on September 7, 1984, and revised on February 7, 1992, July 8, 1994, November 7, 1997, and March 1, 2002 provides that the President and/or the Vice President for Business and Finance, or for the Hospitals of the University and their related facilities, Vice President for Health Services, may grant a waiver from competitive bidding in the event of an emergency, when a sufficient economic reason exists or when the goods or services can be purchased from only a single source, with a report on such waivers to be made quarterly to this Board; and

WHEREAS the Senior Vice President for Business and Finance has submitted a report on waivers of competitive bidding requirements granted for the period of April - June, 2002; and

WHEREAS during the period covered, the Senior Vice President for Business and Finance, at the requests of the departments making the purchases and upon the recommendation of the Purchasing Department, granted 76 waivers of competitive bidding requirements for annual purchases totaling approximately \$13,233,100 as shown on the enclosed exhibit; and

WHEREAS during the period covered, the Vice President for Health Services, at the requests of the Hospitals of the University and their related facilities making purchases, granted 31 waivers of competitive bidding requirements for annual purchases totaling approximately \$8,541,700 as shown on the enclosed exhibit:

NOW THEREFORE

BE IT RESOLVED, That the report on waivers of competitive bidding requirements for the period of April - June 2002, is hereby accepted.

(See Appendix XX for background information, page 515.)

**EMPLOYMENT OF ARCHITECTS/ENGINEERS
AND CONSTRUCTION CONTRACTS**

Resolution No. 2003-47

**WOODY HAYES DRIVE BRIDGE AND STEAM LINE EXTENSION
EARLY CHILDHOOD DEVELOPMENT CENTER AT WEINLAND PARK
BIOLOGICAL SCIENCES – BIOSAFETY LEVEL 3 FACILITY
LINCOLN AND MORRILL TOWERS WALKWAYS
DRAKE UNION PEDESTRIAN BRIDGE**

Synopsis: Authorization to employ architectural/engineering firms for the Early Childhood Development Center at Weinland Park, Biological Sciences – BioSafety Level 3 Facility, Lincoln and Morrill Towers Walkways, and Drake Union Pedestrian Bridger projects and to enter into construction contracts for the Woody Hayes Drive Bridge and Steam Line Extension project is requested.

WHEREAS the University desires to demolish the existing bridges over the Olentangy River and Olentangy River Road and replace them with new bridges and install high-pressure steam line under the bridge structure and connected to the existing lines; and

WHEREAS the total estimated project cost is \$8,400,000 and the total estimated construction cost is \$7,552,712, with funding provided by future University bond proceeds; and

WHEREAS the University desires to design a facility to house an early childhood development center in the Weinland Park area southeast of the Columbus Campus that would include the existing childhood laboratory housed in Campbell Hall with expanded services for additional infants, toddlers, and preschool age children; and

WHEREAS the preliminary project cost estimate is \$5 to \$10 million with the design costs being funded by the College of Human Ecology; and

WHEREAS the University desires to renovate rooms in the Biological Sciences Building and construct an additional mechanical room for the installation of a Bio-Containment Lab that meets Level 3 standards of the Centers for Disease Control; and

WHEREAS the preliminary project cost estimate is \$1.8 million with the design costs being funded by the College of Medicine and Public Health; and

WHEREAS the University desires to replace the eastern elevated walkways at Lincoln and Morrill Towers; and

WHEREAS the preliminary project cost estimate is \$600,000, with the design costs being funded by House Bill 748; and

WHEREAS the University desires to renovate the elevated and at-grade walkways adjacent to Lincoln and Morrill Towers and the Drake Union pedestrian bridge crossing the Olentangy River; and

WHEREAS the preliminary project cost estimate is \$350,000 with the design costs being funded by House Bill 748:

NOW THEREFORE

BE IT RESOLVED, That the President and/or Senior Vice President for Business and Finance be authorized to select qualified architectural/engineering firms as necessary for the Lincoln and Morrill Towers Walkways and Drake Union Pedestrian Bridge projects and that the fees for these services be negotiated between the firms selected and the University; and

**EMPLOYMENT OF ARCHITECTS/ENGINEERS
AND CONSTRUCTION CONTRACTS (contd)**

BE IT RESOLVED, That the President and/or Senior Vice President for Business and Finance be authorized to select qualified architectural/engineering firms as necessary for the Early Childhood Development Center at Weinland Park and Biological Sciences – BioSafety Level 3 Facility projects and that the fees for these services be negotiated between the firms selected and the University, provided that no authorization to enter into construction contracts for either of these projects is to be submitted to the Board for approval until, for that project, there is a memorandum of understanding, including an approved business plan and final cost estimates, executed by all the offices involved; and

BE IT FURTHER RESOLVED, That the President and/or Senior Vice President for Business and Finance be authorized to enter into construction contracts for the Woody Hayes Drive Bridge and Steam Line Extension project in accordance with established University and State of Ohio procedures with all actions to be reported to this Board at the appropriate time.

(See Appendix XXI for background information and maps, page 517.)

SALE OF REAL PROPERTY

Resolution No. 2003-48

**BUSCH BOULEVARD CENTRE
975-1045 MEDITERRANEAN AVENUE AND 6092-6120 BOARDWALK STREET
COLUMBUS, OHIO**

Synopsis: Authorization for the sale of improved real property known as the Busch Boulevard Centre, a retail shopping center located in the northwest section of Columbus, Ohio, is proposed.

WHEREAS the Board of Trustees of The Ohio State University is presented with the opportunity to sell improved real property located at 975-1045 Mediterranean Avenue and 6092-6120 Boardwalk Street in Columbus and known as the Busch Boulevard Centre; and

WHEREAS the total property has an appraised value of \$2,250,000, and the purchaser, S.L. Yassenoff, has agreed to purchase the property at a price of \$2,300,000; and

WHEREAS the appropriate University offices have determined that the sale of this property is in the best interest of the University; and

WHEREAS net proceeds from the sale of the property will be reinvested by the Endowment:

NOW THEREFORE

BE IT RESOLVED, That the President and/or the Senior Vice President for Business and Finance be authorized to sell the University's interest in the Busch Boulevard Centre at 975-1045 Mediterranean Avenue and 6092-6120 Boardwalk Street, at a total price of not less than \$2,300,000, upon such terms and conditions as are deemed to be in the best interest of the University.

(See Appendix XXII for background information and map, page 527.)

TRIBUTE TO DAVID CITINO

Resolution No. 2003-39

[Tribute text is shown on page 481.]

October 4, 2002 meeting, Board of Trustees

Upon motion of Mr. Sofia, seconded by Mrs. Davidson, the Board of Trustees adopted the foregoing resolutions by unanimous roll call vote, cast by Messrs. Patterson, Sofia, Slane, McFerson, Borrer, and Judge Duncan, Mses. Longaberger and Davidson.

--0--

Thereupon the Board adjourned to meet Friday, November 1, 2002, at The Ohio State University Longaberger Alumni House, Columbus, Ohio.

Attest:

Maureen T. Sharkey
Assistant Secretary

James F. Patterson
Chairman

**Waivers of Competitive Bidding Requirements
April-June 2002**

(APPENDIX XX)

<u>Category</u>	<u>Total</u>	<u>Sole Source</u>	<u>Emergency</u>	<u>Sufficient Economic Reason</u>
Hospitals - Professional Health Care Services	\$3,620,000	\$575,000	\$0	\$3,045,000
Hospitals - Equipment and Services	\$4,921,732	\$2,201,733	\$152,594	\$2,567,405
Merchandise For Resale	\$6,781,334	\$6,781,334	\$0	\$0
Instructional and Research Equipment and Services	\$3,224,493	\$1,238,448	\$0	\$1,986,045
Administrative Support Equipment and Services	\$3,111,305	\$1,921,371	\$560,459	\$629,475
Conference Facilities	\$116,000	\$56,000	\$0	\$60,000
TOTAL	\$21,774,864	\$12,773,886	\$713,053	\$8,287,925

Woody Hayes Drive Bridge and Steam Line Extension

5062-PF990609



Requesting Agency(s): PHYSICAL FACILITIES

Location(s): Unidentified Bridge-Col. Gross Sq. Ft.: 0 Age:

Description: The Woody Hayes bridges that span the Olentangy River and Olentangy River Road were constructed in 1921. A detailed engineering inspection in February 1995 indicated a need for extensive structural rehabilitation. This project would demolish the existing bridges over the Olentangy River & Olentangy River Road and replace them with new bridges that have four 12' lanes with 10' sidewalks on each side, as well as provide ADA accessibility to the bridges from the parking areas. The bridges would be built using part-width construction allowing maintenance of traffic on the bridges. A vertical clearance of 15'6" is required to meet the current AASHTO standard.

Included with this project is the construction of a high-pressure 10" steam line, which would be installed on the bridge under-structure and connected to the existing line near St. John Arena & Ag Eng. The recommended single structure would allow for the opening of the river corridor as well as accommodating a bike path along the east bank of the Olentangy River without encroaching on the waterway.

Project Team:

Facility Planner: Is Unassigned

Project Captain: Tricia Petras
(petras.6@osu.edu)

Project Assistant: Karen Cogley
(cogley.1@osu.edu)

Field Coordinator: Is Unassigned

Source of Funds:

	Original	Revised
Future Univ. Bond Issues	\$6,500,000.00	\$8,400,000.00
Total:	\$6,500,000.00	\$8,400,000.00

Project Information:

Project originally approved by the Board of Trustees on July 2, 1999. Since then, the project budget has increased to incorporate project #5062-PF990627. Budget and Funding from that project were moved here.

Uses of Funds:

	Original	Revised
Construction	\$5,850,000.00	\$7,546,206.31
Contingency	\$44,225.69	\$44,225.69
Design	\$650,000.00	\$782,280.00
University Administration	\$27,288.00	\$27,288.00
Total:	\$6,571,513.69	\$8,400,000.00

Schedule:

	Projected	Revised	Actual
Planning			
Arch/Engr Approved by B/T	07/02/1999		07/02/1999
Bidding Approved B/T	07/02/1999	10/04/2002	
Construction			
Construction Start	07/01/2000	09/30/2002	
Completion	07/01/2002	03/31/2005	

Woody Hayes Drive Bridge and Steam Line Extension

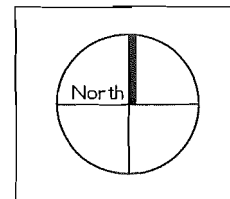
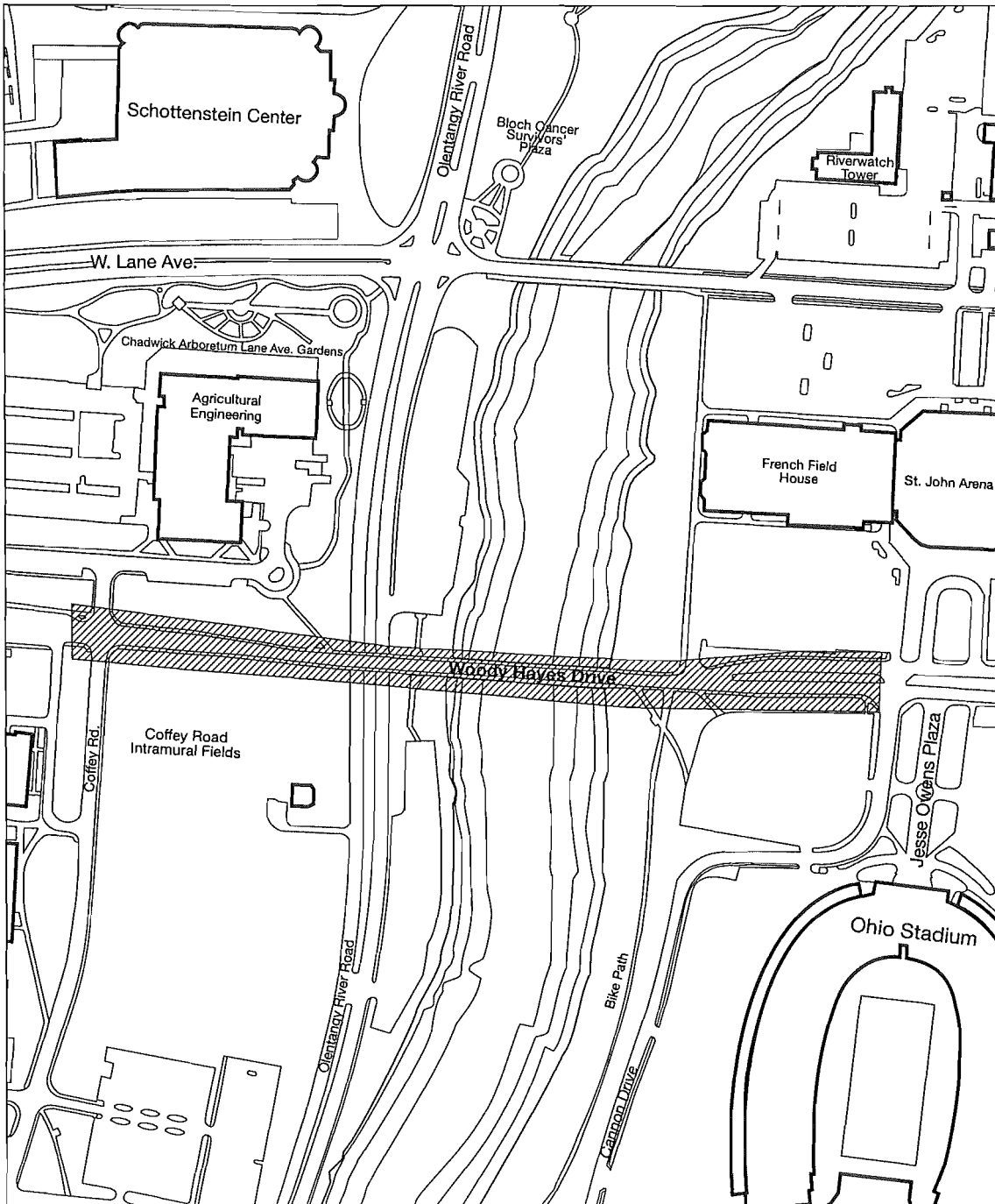

Office of Business and Finance
Office of Facilities Planning and Development

December 9, 2000



Early Childhood Development Center at Weinland Park

315-2002-925

Requesting Agency(s): HUMAN ECOLOGY ADMINISTRATION
Location(s): Site - See Comments. **Gross Sq. Ft.:** 0 **Age:**

Description: Construct a facility to house an early childhood development center in the Weinland Park area southeast of the Columbus campus. The existing childhood laboratory housed in Campbell Hall will be relocated to this new facility and will expand its services to include additional infants, toddlers, and preschool age children.

Project Team:
Facility Planner: Alex Cofield
(cofield.3@osu.edu)
Project Captain: John Frazier
(frazier.2@osu.edu)
Project Assistant: Is Unassigned
Field Coordinator: Is Unassigned

Project Information:
Land acquisition may be arranged through Campus Partners. The preliminary cost estimate for the project is \$5 - \$10 million.

Schedule:	Projected	Revised	Actual
Planning Arch/Engr Approved by B/T	10/04/2002		

Early Childhood Development Center at Weinland Park

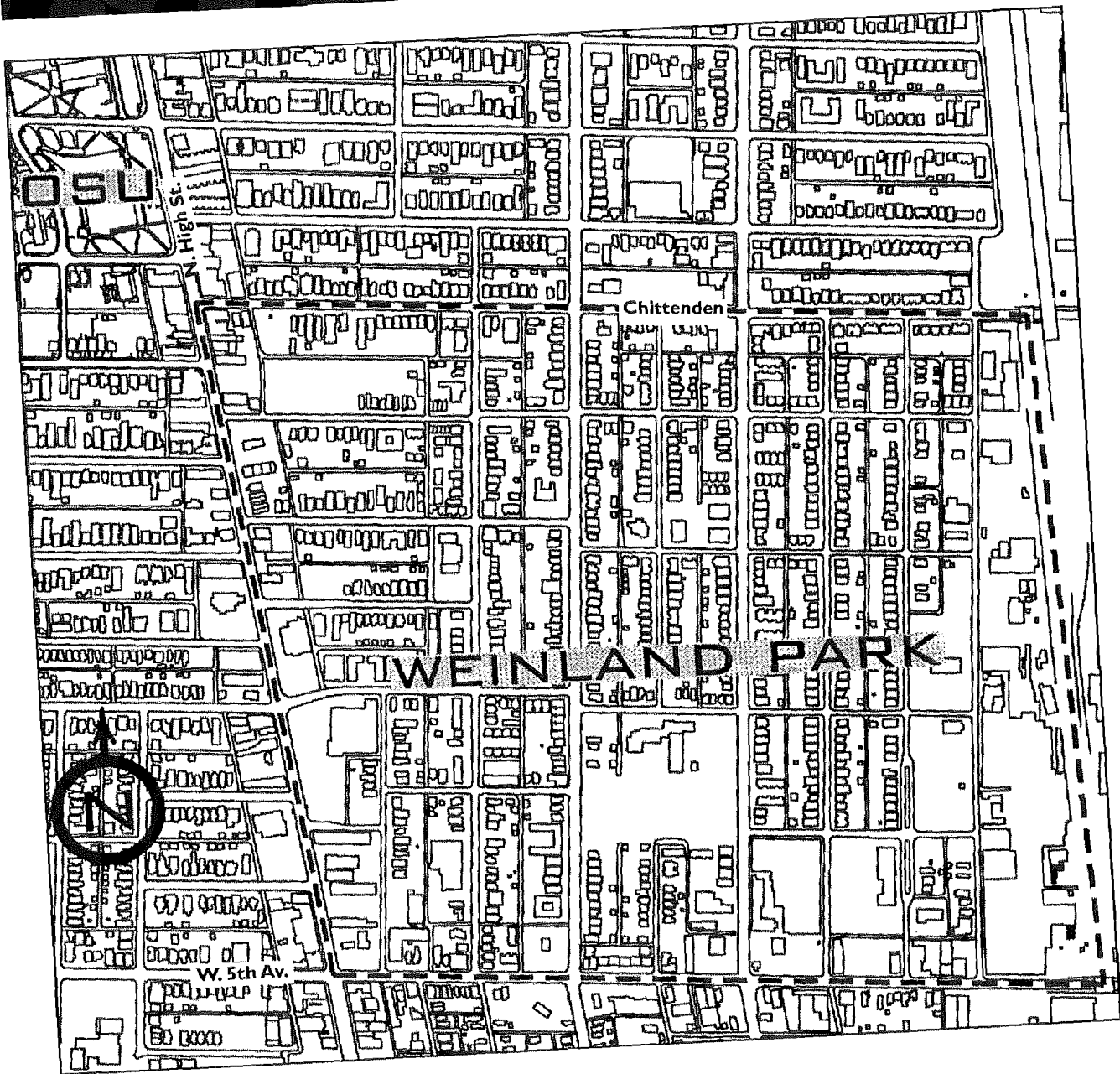

Site to be selected within Weinland Park



Biological Sciences - Bio Safety Level 3 Facility

315-2002-926

Requesting Agency(s): MEDICINE AND PUBLIC HEALTH ADMIN

Location(s): BIOLOGICAL SCIENCES BUILDING Gross Sq. Ft.: 182,129 Age: 1970

Description: Renovate rooms in Bio Science Building and construct an additional mechanical room for the installation of a Bio-Containment Lab that meets Level 3 standards of CDC.

Project Team:

Facility Planner: Teresa Yu
(yu.195@osu.edu)
Project Captain: Steve Middleton
(middleton.52@osu.edu)
Project Assistant: Lisa Baldwin
(baldwin.10@osu.edu)
Field Coordinator: Is Unassigned

Project Information:

Formerly known as 50700-R024734.
Preliminary project estimate of \$1.8 million.

Schedule:	Projected	Revised	Actual
Planning Arch/Engr Approved by B/T	10/04/2002		

Biological Science - Bio Safety Level 3 Facility

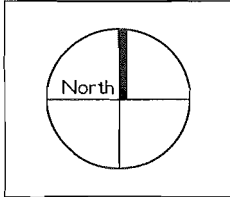
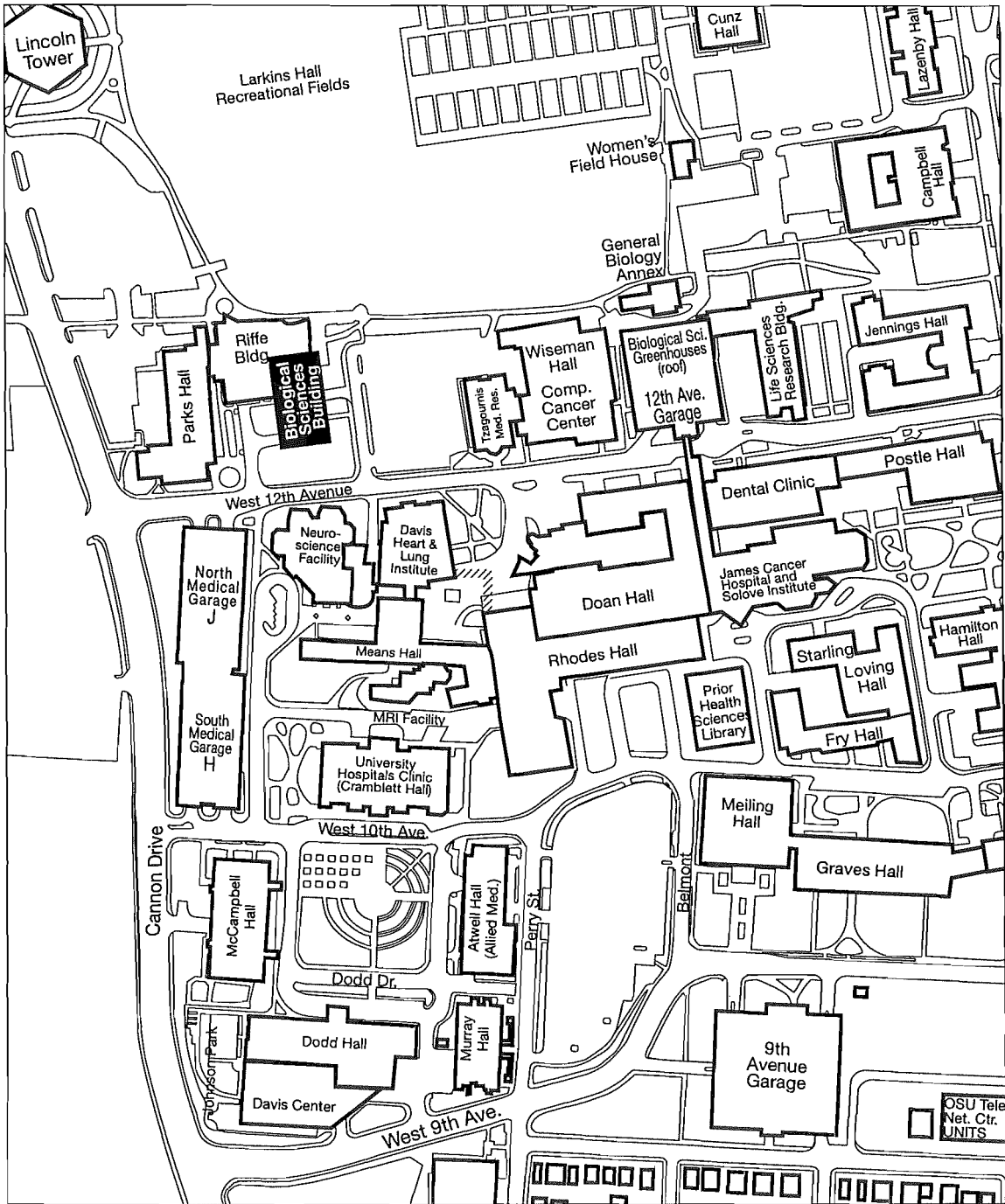

Office of Business and Finance
Office of Facilities Planning and Development

September 24, 2002



Lincoln and Morrill Tower Walkways

315-2002-927

Requesting Agency(s): PHYSICAL FACILITIES

Location(s): Unidentified Bridge-Col. Gross Sq. Ft.: 0 Age:

Description: Replace the eastern elevated walkways off Lincoln and Morrill Towers.

Project Team:

Facility Planner: Is Unassigned

Project Captain: Bo Zhang
(zhang.403@osu.edu)

Project Assistant: Mikki Reese
(reese.153@osu.edu)

Field Coordinator: Is Unassigned

Project Information:

Preliminary project estimate of \$600,000.

Schedule:	Projected	Revised	Actual
Planning Arch/Engr Approved by B/T	10/04/2002		

Lincoln and Morrill Towers Walkways

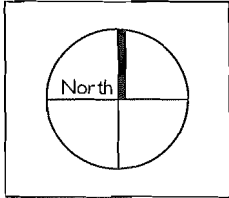
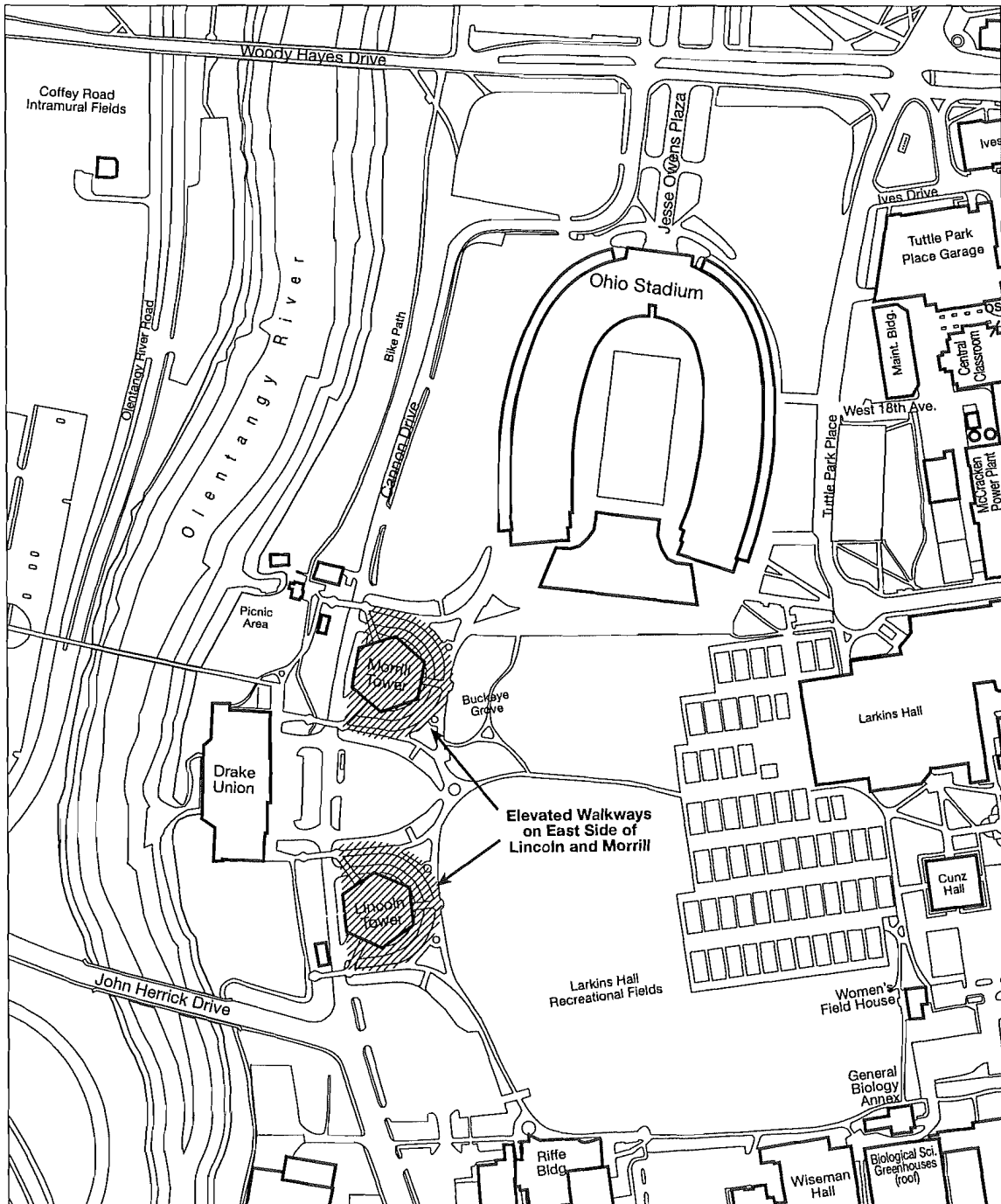

Office of Business and Finance
Office of Facilities Planning and Development

September 24, 2002



Requesting Agency(s): PHYSICAL FACILITIES
Location(s): Unidentified Bridge-Col. **Gross Sq. Ft.:** 0 **Age:**

Description: Renovate the elevated and at grade walkways adjacent to Lincoln and Morrill Towers and the Drake Union pedestrian bridge crossing the Olentangy River.

Project Team:
Facility Planner: Is Unassigned
Project Captain: Bo Zhang
 (zhang.403@osu.edu)
Project Assistant: Steve Deedrick
 (deedrick.4@osu.edu)
Field Coordinator: Is Unassigned

Project Information:
 Preliminary project estimate of \$350,000.

Schedule:	Projected	Revised	Actual
Planning Arch/Engr Approved by B/T	10/04/2002		

Drake Union Pedestrian Bridge

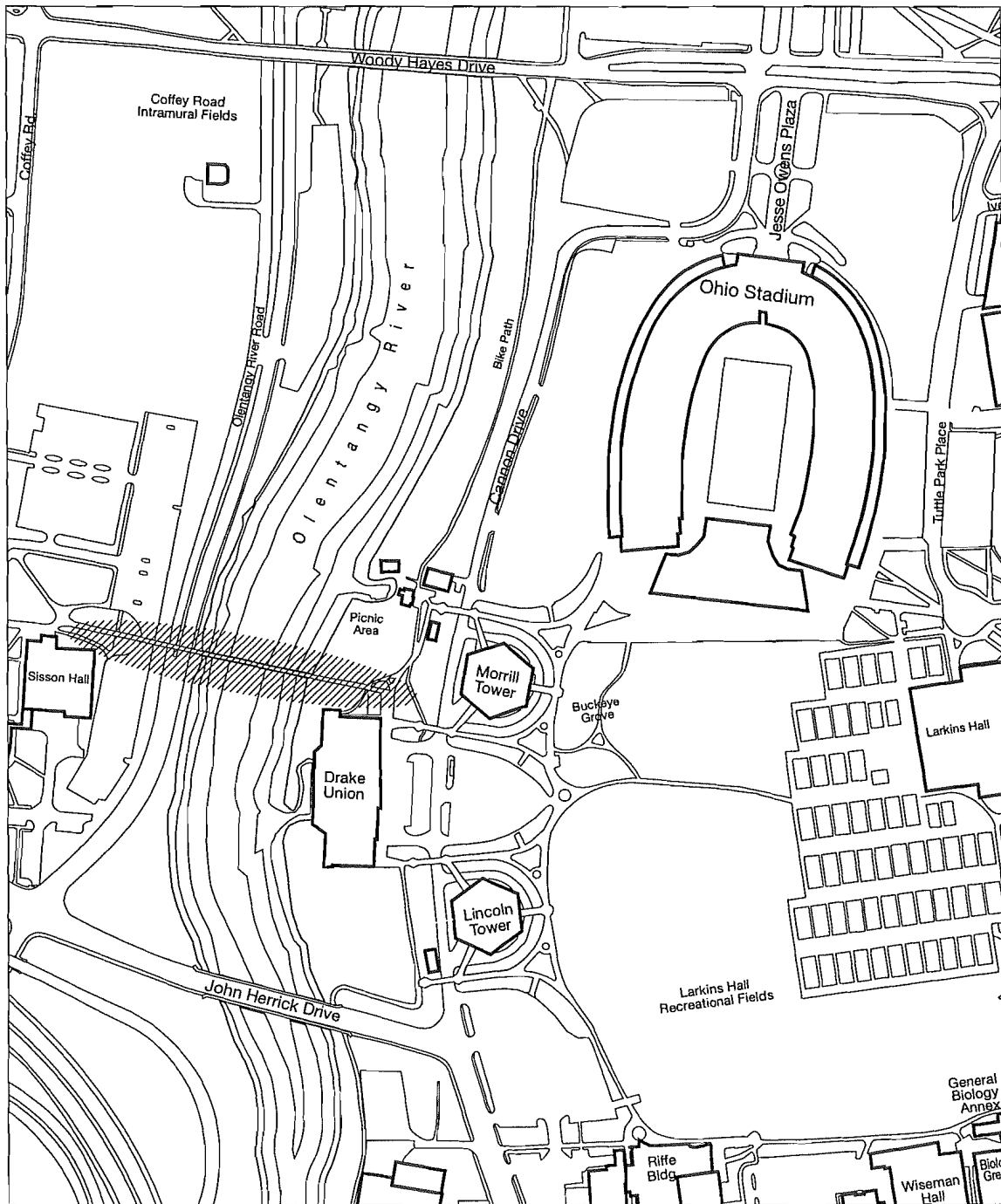

Office of Business and Finance
Office of Facilities Planning and Development

September 24, 2002

SALE OF REAL PROPERTY

BUSCH BOULEVARD CENTRE
975-1045 MEDITERRANEAN AVENUE AND 6092-6120 BOARDWALK STREET
COLUMBUS, OHIO

Location and Description

The property to be sold consists of a retail and commercial shopping center of approximately 50,000 square feet on a 3.9-acre site located just north of State Route 161 (Dublin-Granville Road) and just west of the Interstate 71 interchange. The property is titled in the name of the Board of Trustees of The Ohio State University and is held as a part of the University Endowment.

Appraisal and Purchase Price

An MAI appraisal conducted by Samuel D. Koon and Associates in August 2002 valued the property at \$2,250,000. The purchaser, S. L. Yassenoff, of Columbus, Ohio, has agreed to buy the property at a price of \$2,300,000. The Endowment is liquidating certain of its real estate holdings as a matter of routine review and improvement of its portfolio. Proceeds will be reinvested in the Endowment.

Proposed Sale of Property Busch Boulevard Centre

975-1045 Mediterranean Avenue and 6092-6120 Boardwalk Street

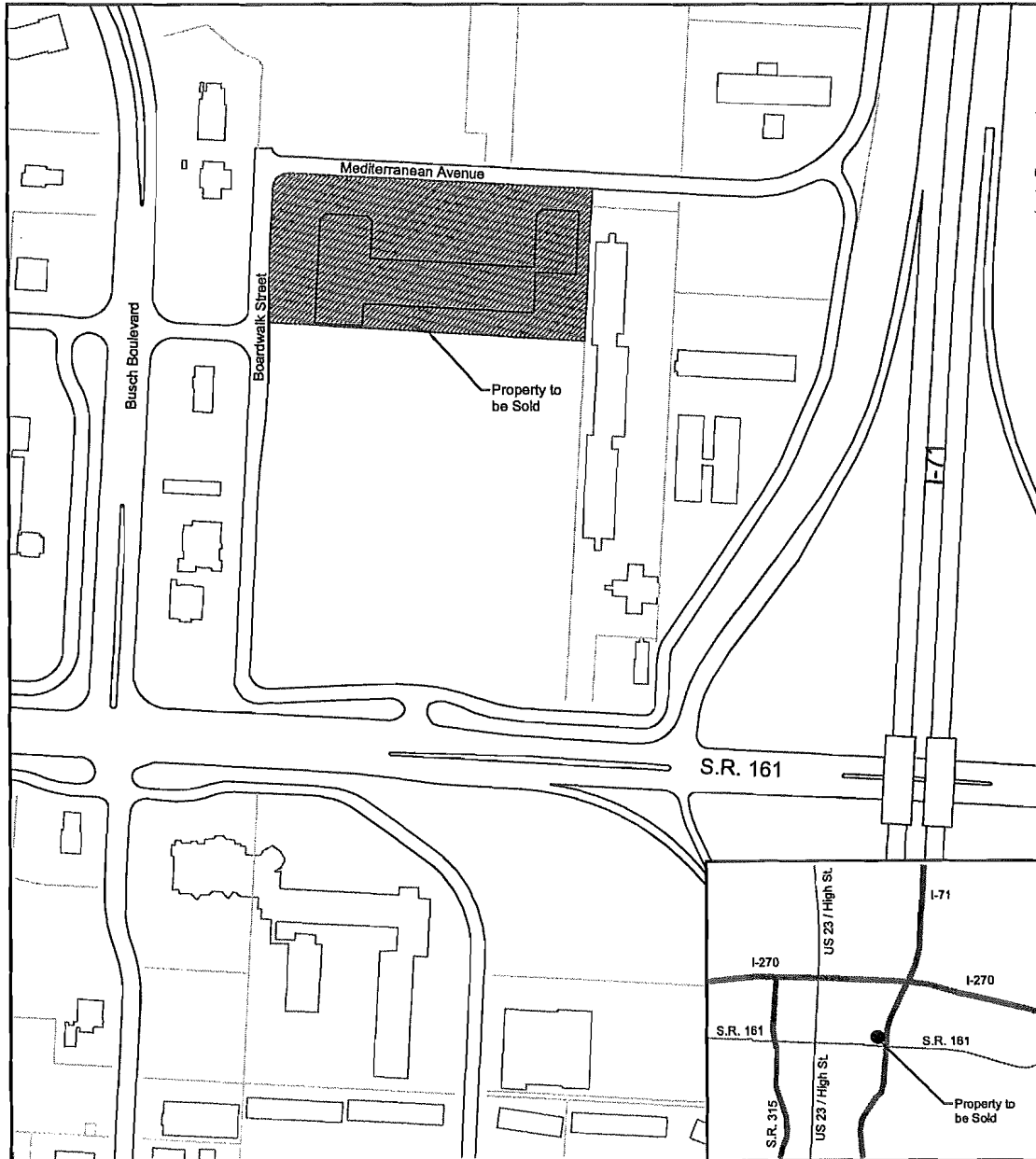

No True Scale

Office of Business and Finance
October 4, 2002

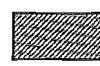

 Proposed Sale of Property

Map Provided by University Engineer's Office

THE OHIO STATE UNIVERSITY
OFFICIAL PROCEEDINGS OF THE
ONE THOUSAND THREE HUNDRED AND EIGHTY-EIGHTH MEETING
OF THE BOARD OF TRUSTEES

Columbus, Ohio, November 1, 2002

The Board of Trustees met at its regular monthly meeting on Friday, November 1, 2002, at The Ohio State University Longaberger Alumni House, Columbus, Ohio, pursuant to adjournment.

**

**

**

Minutes of the last meeting were approved.

**

**

**

November 1, 2002 meeting, Board of Trustees

The Chairman, Mr. Patterson, called the meeting of the Board of Trustees to order on November 1, 2002, at 10:40 a.m. He requested the Assistant Secretary to call the roll.

Present: James F. Patterson, Chairman, Zuheir Sofia, Tami Longaberger, Daniel M. Slane, Robert M. Duncan, Karen L. Hendricks, Dimon R. McFerson, Jo Ann Davidson, Douglas G. Borrer, Joseph A. Shultz, and Paula A. Habib.

--0--

PRESIDENT'S REPORT

President Karen A. Holbrook:

I'm going to do two different things today: first, I have passed out to all of the Trustees a handout called, "Update." Basically, this is an inventory list of what I've been doing for the first month I've been here. I think you'll see that the list is grouped as to whom I've been interacting with and what activities I've been involved with. I hope you feel that this has been a productive month of good activities.

I will highlight a few of these things and a few of the themes that have come out of them. I took the document and tried to take each one of the things I have done and put it into the Academic Plan, as to how each of these things fits in, what the goals are, and what I have been doing that makes a difference to the goals of the Academic Plan.

I ended up very late last night taking it back out and putting it in a different format, again, because I don't want to stretch. I don't want to take things that are purely activities to introduce me to the campus and try to fit them into something that I would say is strategic, because it's really not. I'm still trying to get used to where I am and getting to know people. Once you know people, you can then be more strategic and more sensible in putting things in as to how they are going to help advance the direction we're going.

What I have done, in coming out of all of these different activities and meetings, is pick up a number of themes that are pervasive on this campus and important for us. In walking through this, you will see a number of things that come out of meetings with students, faculty, and other organizations that suggest what the issues are on this campus. I don't think there are any surprises, because they are the issues that you all knew about as you designed the Academic Plan and the Diversity Plan.

Diversity comes out very prominently. In every interaction I have, diversity comes out as a major theme every single day in all of the things that are going on. I've met with a variety of different groups on campus to talk about diversity. The interesting thing is I get two different senses, and I'm going to mention both of them.

I get a sense that there are many things that we are doing that are very good and very strong. Our numbers are looking good. If you were to do an inventory of what is going on on campus, you would see that there are so many different activities. If you would look at the numbers, you would see that we're making improvements.

The other part that comes out when you meet people one-on-one is how are we changing the environment where people are working? How do people feel? The Office of Minority Affairs had a wonderful reception the other night and my comment to this group was, "I hope each one of you feels as warmly welcome in this environment as I do." My sense is we have a way to go to make that still

PRESIDENT'S REPORT (contd)

President Holbrook: (contd)

happen for everybody. That's one of our biggest challenges. How do we bring the comfort level up for everybody on campus, so they do feel as good as I do?

Those are the things that are harder to design and fix. It is not easy to fix things, but you can with money and appropriate guidelines. People and how they deal with other people in their hearts is what is really going to be difficult to work on. That is exactly what we have to think about very seriously. That comes out and there have been some wonderful ideas.

Now having said that in a slightly negative sense, I have to say all of the positives that I have gotten from students and the enthusiasm for having an environment that they're comfortable in, and working together to bring that comfort level up has been so impressive to me. You've all seen the letter that I sent out broadly over the Internet about tolerance and about my extraordinary sense of our student body in wanting to do something positive for this University. I feel very good about our student activities in this regard, but that is one thing that comes through virtually every day in every activity that I'm involved in.

The second thing that comes out is when you look at all of these activities, you can't help but step back and think of who are the partners of this University. That is something I'm going to address in my other piece. We have extraordinary partners, and I'm not telling you something you don't know. Because of our alumni groups and our support downtown, we have partners everywhere. They help us with all of our activities and our partners for progress are very important to us. This comes out in all of the different kinds of meetings that I've participated in, whether they are peer partners or in different sectors other than academia. We have many, many partners. This is one of the great strengths we have.

As I work across campus with groups, the other issue that comes out repeatedly is the emphasis on faculty-student engagement and the undergraduate experience. You're going to have a nice presentation today that will emphasize the First Year Experience. What is the most heartening about this is how the students really are enthusiastic about that kind of engagement. I've had a chance to work with Eddie Pauline on some ideas of things we can do to enhance the student-faculty relationship. My suggestion to him is, let's talk about it, let's you and I exchange ideas, and then let's have you come back with the suggestions. Because the suggestions are going to mean a whole lot more coming from the students to the administration than they are from the administration saying, "These are the kinds of things you should do." So, I feel good about those interactions.

Another thing that comes out very clearly is technology transfer and economic development for this University. We have heard about that before and it is very important, but it is clear that our Columbus community is very supportive of those activities for us.

Another theme that is clear is access -- cost of education -- and, I would add, excellence. That is something that we talk about a lot and are also going to have to work on. The last theme is University and community citizenship. We emphasize citizenship among our students and we can see so many tangible ways that our students are part of that citizenship through their volunteer activities, their connections, and even last weekend through the "Make a Difference Day."

PRESIDENT'S REPORT (contd)

President Holbrook: (contd)

The other side of the coin is that a different aspect of our citizenship is recognized on game days in ways that are not respectful and do not demonstrate tolerance. We're going to start looking at that among the senior leadership thinking about what kind of message we send to our community with some of the signals that we have on game day. We can undermine all the great things we do academically by some of the activities that go on on game day. I think we want to look at that and say, "Is that the message we want to say about The Ohio State University?" Or do we want those other messages about our academic enterprise and student citizenship to come out as the primary emphasis?

Let me say two things particularly about the inventory that you have that I think are very important. We had the great privilege of hosting Senators Voinovich and DeWine this week on our campus for a luncheon with a number of people on the faculty, several representatives from our Board of Trustees, students, and faculty representatives. This was a very positive first step in talking about what are our federal priorities. How can we be of benefit to our delegation in Washington? How can we support them in what they're doing? How can Ohio State be on their agenda? How can we just simply give them information to do their jobs more effectively when they want it? That was an excellent first step and it goes along with the last comment I'm going to make here.

We are in the search for two new positions right now. We have an interim vice president for Government Relations and we have Lee Tashjian leaving us as vice president for University Relations. Certainly we'll have many opportunities to say goodbye, but this is his last Board meeting with us. At an alumni banquet last week we gave an award to a person from the University of Florida, who is in a similar position to Lee's but in a step down. This individual particularly wanted to talk to Lee because they are doing a survey at Florida of top institutions in communications and looking for models to build their program on, and The Ohio State University is one of those models. Lee, I think that is a very nice thing to go out knowing, that you have helped us become a model. Thank you, and we wish you well.

We're looking very closely at developing those two job descriptions and working very hard at a plan for Government Relations that will take into consideration all that we're doing in the state, the federal government, our federal agencies, and the organizations we belong to. We will be searching very hard to fill these positions shortly.

At each Board meeting I'd like to say something about an issue that I think is important on the campus and some of the issues I raised when I was here for my very first remarks. Today I want to talk about the image of this University that I think is important. There were a confluence of statements that have come together recently -- and what I'm going to focus on is our "bigness."

Last week I attended the AAU president's meeting and at that meeting we all talked about what we're doing in our own institutions. I sat there thinking, "You know, we're all excellent, committed, entrepreneurial, forward-looking, student-centered, accountable, efficient, analytical, critical thinking, and nimble. All of us are, because we're all great universities. So what are we? What is Ohio State? What makes us unique? What makes us special?" I asked the same thing of the search committee, "What do we want to be known for? What are the characteristics that make us really something different?"

Secondly, a couple of weeks ago Provost Ray and I met with the President and Provost's Advisory Committee. This is a group composed of our eminent

PRESIDENT'S REPORT (contd)

President Holbrook: (contd)

scholars and distinguished professors and this group gave us ten recommendations, one of which is that we need an image makeover. I thought about that and wondered what they really meant by that.

Thirdly, I thought of a comment that came from Ken Lee last weekend during the Food Science and Technology presentation at the pre-game brunch. He said, "We're building an academic program that will make our athletes proud." He meant it tongue-in-cheek, and it was funny and cute, but it suggests that maybe we're better known for our athletic programs than we are for our academic programs.

And, finally – and this is to me the most serious comment – an article was published in the *Toledo Blade* on October 3, that included a statement that I pulled out and said to Lee Tashjian, "You know, we need to think about this." I'm going to quote from the article: "A cautionary note should be sounded. Ohio State remains a university that is hurt by its immense size." I thought that was a very telling comment, but not on target. I took this out of context, because it goes on to say more positive things, but, nonetheless, that statement does resonate with what we hear from parents, students, and people who are thinking about coming to The Ohio State University.

We are big. We are almost frighteningly and intimidatingly big. But even what I said in my opening remarks when I first came here, I said, "Yes, a theme runs through Ohio State's literature -- that we're big. It is the first impression of Ohio State from any perspective. In my view, our bigness needs to convey our connectedness and what we can do by being big to connect with reality, with all of our constituencies, and externally – all over the world." To me it seems like we have to start emphasizing that connectedness, our bigness, and stop being even slightly self-conscious about our size, about thinking of it as a liability, and to begin to emphasize our size as our uniqueness. Perhaps one thing we can start with is our strengths because of our size. It needs to be equated with our excellence, our leadership among institutions of higher education, and our value to the state in the future.

For example, during the Parent's Weekend brunch, I said to parents, "Think of what we can do with our physical infrastructure, in terms of buildings, laboratories, equipment, special facilities, field stations, museums, galleries, libraries, computer facilities, clinical facilities, agricultural facilities, the supercomputer; our computer programs in the arts; career services; theaters; our own newspaper and radio station; incubators; support facilities; and infrastructure for athletic programs and students in intramural programs. Think about any student wanting to access faculty talent." There is so much faculty talent and expertise here that we do not have to create it and import it, we can do it all with what we have here. It is a phenomenal advantage. We have 600 activities for students.

Now I like to create mental pictures of what this might look like if you were to think about the bigness, and the connectedness, and the outreach of this University. I thought about taking a very small college like the College of the Arts -- and I thought of that one because one might think the College of the Arts does things pretty much in the confines of their own college and are not particularly connected. I asked for some material from Karen Bell. What she provided to me is that her faculty are doing teaching and research. Teaching is important, and they have 15 programs in humanities, six programs in social science and behavioral sciences, programs in biological sciences, mathematical and physical sciences, and business; unlikely programs in the College of Engineering, such as

PRESIDENT'S REPORT (contd)

President Holbrook: (contd)

the Center for Automotive Research Institute and the Institute for Ergonomics, Industrial Welding and Systems Engineering; and programs in Medicine and Public Health. The College of the Arts is engaged in research with a number of companies. Then you add the connections of the faculty with their colleagues broadly, and then internationally.

Now, you take that one image of that college that is connected – plus its alumni all over the world – and take all of our other schools and colleges and take some of the big ones, like Medicine and Engineering, and think of all of their connections and put that picture together. I think the sense that you get is that our bigness is an incredible asset. The relevance is enormous, the outreach is huge, and our opportunities and strengths are unparalleled because of our size.

The challenge then – and this is where I hope I'm going to lead into the program that you have today – is for our students to be able to access that expertise and to take advantage of all of these resources. So our challenge is to create a "big small University." One where our students are not overwhelmed by their environment, but they are overwhelmed with their opportunity. And I mean that truly in a positive sense. Student Affairs is very much aware of the need to make a large school small. They do that through a number of programs, such as Dr. Freeman's office, but many offices. I'm going to give a quote from a sophomore student, Aaron Friedman, who said, "The key to making any institution like The Ohio State University feel smaller is involvement." This is our challenge, to help students become involved, so that they don't have to feel like they're in a big environment, but a small environment.

To close, how are we really hurt by our size, as the *Toledo Blade* charges? I see that we're only enhanced by our size, as long as we understand how to make it manageable and how to access the University in smaller bites. In that case, then, our size has to be an extraordinary asset. When Chairman Patterson and I discussed this topic together a week or so ago, he said, "You can make a large university small, but you can't take a small one and make it large in the same way that The Ohio State University is."

I for one see our "bigness" as one of our terrific assets and one that we really need to promote. If nothing else, we can at least start by saying that is one of our truly unique characteristics and we're really proud of it. Thanks.

Mr. Patterson:

Thank you, Karen. There are not many topics of more importance than the last one that you addressed for the University as a whole.

(See Appendix XXIII for President Holbrook's "Update," page 571.)

--0--

STUDENT RECOGNITION AWARD

Ms. Habib:

The Student Recognition Award is presented by the Board of Trustees to honor a student's achievement in his or her area of study, service to the University and/or area/community, and/or research achievements that have been a credit to the college and the University.

STUDENT RECOGNITION AWARD (contd)

Ms. Habib: (contd)

This month's recipient is Grace Nwoku, who was nominated by Dean Tripodi in the College of Social Work. Grace received her Bachelor of Science degree from the College of Human Ecology at Cornell University. She earned a dual degree in human service studies and policy analysis and management. Ms. Nwoku is currently a master's student in the College of Social Work in the advanced standing option, which means she is completing the master's degree in one full year of course and field work. She is a graduate enrichment fellow concentrating in social administration.

In addition to her formal education program, she is spending some time as a research assistant in a project that is evaluating the effectiveness of 20 youth development programs in Central Ohio. Grace is currently interning at the Department of Rehabilitation and Corrections' Bureau of Mental Health Services. According to Dr. Theresa Early, a professor in the College of Social Work, Ms. Nwoku exemplifies the social work profession's commitments to empowerment and social justice.

As she wrote in her personal statement in applying to the program, "In five years I hope to be in a position to educate, advocate, and perhaps even legislate on economic inadequacies in this country and, of course, provide positive outcomes for such problems."

Ms. Nwoku aspires to a career in non-profit management and social activism, especially around issues that affect women, families, and children. Being a student myself, it is a great honor for me to be able to present a student like Grace to the Board of Trustees. The Board appreciates the chance to meet students, especially ones who exemplify exactly how bright and committed the students at Ohio State really are.

Grace, on behalf of Chairman Patterson and the Board of Trustees, I would like to present you with the Student Recognition Award. Congratulations.

Ms. Ugwulo Grace Nwoku:

I'd like to thank the Board for this honor – I am truly happy with this. I also want to thank my dean, Dr. Tripodi, and my professors, Dr. Dawn Anderson-Butcher and Dr. Theresa Early, for making my experience here so enriching. Thank you.

--0--

**FIRST YEAR EXPERIENCE/RECRUITMENT AND RETENTION STRATEGIES/
NEW UNDERGRADUATE STUDENT PROFILES**

Mr. Patterson:

One of the areas that Karen's timely comments led into is the student experience. Dr. Mabel Freeman, whom many of us know so well, does this work with such passion. She is going to lead a presentation to the Board on the First Year Experience, recruitment and retention strategies, and some of our new undergraduate student profiles. Dr. Freeman --

Dr. Mabel Freeman: [PowerPoint Presentation]

Thank you very much, Chairman Patterson and President Holbrook. We really are pleased to be able to be here and we come in large numbers. We come with a theme very much consistent with what President Holbrook was just saying and

**FIRST YEAR EXPERIENCE/RECRUITMENT AND RETENTION STRATEGIES/
NEW UNDERGRADUATE STUDENT PROFILES (contd)**

Dr. Freeman: (contd)

so there are many of us because, it takes a lot of people to do this. We're going to try and run through a little bit of "Student Recruitment 101" and give you an idea first of all about what it takes to bring in our undergraduate students, and then talk about what happens when they get here, the transition, and the first year.

Helping today -- because they are very key to all of this -- are a number of folks that you'll be hearing from. They are sitting at the table, and I'll introduce them as we get to that point in time. I would also like to quickly introduce a few people that are sitting behind us who are very instrumental to all that goes on in the Undergraduate Admissions and First Year Experience.

Phyllis Miller, director of Orientation, makes sure that literally thousands and thousands of students and parents have a wonderful experience when they come in for orientation. Obviously the largest group comes in the summer, but we have orientation all four quarters for both freshmen and transfers. Next is Gail Stephenoff, and she leads the Office of Enrollment Management. This is the group that really tries to make sure that we've got the right number of students, not only coming to Ohio State, but, then, matriculating through the different majors and colleges at the University. Next is Stephanie Sanders, who is responsible for the competitive admissions process. Since we are no longer an open admissions institution on the Columbus campus, Stephanie directs the process of reviewing the applications and making sure that we're bringing in the most talented and diverse freshman class that we can.

Finally, I would like to introduce Eric Reasoner, our wonderful administrative associate. He is the only person who, on any given day at any hour, knows everything that is going on in Undergraduate Admissions and the First Year Experience. Eric is handing out some folders for you to look at at your leisure, as we'll be talking about these things during the presentation.

Sitting to my right is Allen Kraus, and you'll be hearing from Allen. He directs all of the publications, marketing communications, etc., but he's also very good on working the PowerPoint presentation that we're going to give you.

We thought we would start by just pointing out an overview of the changing profile of the entering freshman class. We've tried to condense it a little bit rather than put every single year in there, just to make it easier for today's presentation.

As I think many of you know, in 1995 the University made its decision to significantly address making sure that the freshmen coming into the University were going to be graduating from the University. As you know, it is not about who comes in, but it is about who leaves with a diploma. As we talk about competitive admissions, we particularly look back to 1995 as a marker year. I think what's important -- we've given you 1995, the last two years, and then this current incoming class -- is that we've maintained relatively the same size freshman class. The last two years our target has been 5,850 students and we've gone just a few over, mostly to keep Bill Shkurti very happy. We have no problem when it's a few students above the target, but we have to be very careful that we maintain a class size for which we will be able to have residence hall and class space. So, we don't want to go too far over that target.

As we look at the profile of the class, many people use ACT or SAT score ranges around the country and we are predominantly an ACT school. As you can see,

**FIRST YEAR EXPERIENCE/RECRUITMENT AND RETENTION STRATEGIES/
NEW UNDERGRADUATE STUDENT PROFILES (contd)**

Dr. Freeman: (contd)

there has clearly been an increase from that 22.8 average ACT score in 1995 to the 25.2. You will notice that the last two years, it's been the same ACT score.

To give you a context for that ACT, the national average this year for all incoming college students, or all students who took the ACT last year, was 20.8. The average for the State of Ohio was a 21.4. So you can see, when we're at a 25.2, we are significantly ahead of where the predominant group of students are when we're talking that score range. So it gets a lot tougher to continue moving up, but that's certainly our goal.

As we look at the top 10 and top 25 percent of the high school class – back in 1995, about one out of five of our entering freshmen graduated in the top 10 percent of their high school class. We're now at one out of three. We'd like to get that up to at least 40 percent of the incoming freshmen being in the top 10 percent of their high school class. The same is true in the top 25 percent – we're now two out of every three freshmen coming in this year graduated in the top quartile of their high school. We'd like to get that to about 80 percent, and that is a challenging goal, but that's where we would like to go.

We used the University Scholars as a marker. Those are the students who graduate typically in the top 3 percent of their high school class and have a 29 ACT or a 1300 SAT or higher. We had quite a jump last year and, while we would have liked to have maintained that jump, we're going to get back up there again. This fall we brought in 716 of these students. Again, given those criteria, that is a remarkable number.

We had a little problem with valedictorians this year and we're looking into that to try to figure out what we can do. We certainly want high school valedictorians in our freshman class. We do not offer any type of special scholarship for them, and many institutions do, but we're not sure that's the only solution to that challenge. The number of National Merit, Achievement, and Hispanic scholars have been increasing. Again, that puts us in about the top 20 universities in the country for the total number of students who are National Merit, National Achievement, and National Hispanic scholars. So we are pleased about that.

We then have our distribution of students and as we look at students of color -- last year about 19.2 percent of the class were students of color; this year, it's 19.3 percent. That is certainly something that is very important. The composition of the freshman class is enhanced, we believe, by the diversity of that class. So we work very closely, particularly with the Office of Minority Affairs, to do that.

We went down a little bit this year in out-of-state residents. This was mostly explained by the international student decline, because non-residents includes both domestic and international students. Actually, when we look at domestic out-of-state students, we are, I think, one or two up from last year. But there is no question there was a decline in international students. I talked with Marie Taris, director of the Graduate, International, and Professional Admissions, to ask her if she wanted me to share any comments about that. Obviously, last year was a particularly strong year. Probably the biggest factor for that drop in international students has to do with the fact that Ohio State now is requiring an ACT or SAT test score for international students, along with the TOEFL. This was a new factor this year. A second factor is that, for undergraduate international students, we have always had a significant number of students from Malaysia and Indonesia, both countries that had much difficulty in getting their

**FIRST YEAR EXPERIENCE/RECRUITMENT AND RETENTION STRATEGIES/
NEW UNDERGRADUATE STUDENT PROFILES (contd)**

Dr. Freeman: (contd)

students into study abroad programs this year because of many of the sanctions that came after September 11. Marie would note those two factors, particularly, and their office is working to have a stronger year this year.

If you look at 1995 versus 2002, there has been a lot of talk about remedial course work at universities within Ohio. You can see that by bringing in stronger classes we have a smaller number of students who need to start with remedial course work.

As we look at all of this and talk about bringing in that class, it is a collaborative effort to do something this big. This is not just an effort of the Undergraduate Admissions staff, this is taking our colleges and academic departments, the faculty, the Honors and Scholars Center, the Office of Minority Affairs, and alumni all participating in this in order to bring in a class.

As we look at our recruitment strategy, we can really identify various groups of students. We talk about wanting to bring in honors students and those are the students who will be able to participate in the strongest programs on this campus. I believe you've heard in the past about some scholars programs that were initiated two and three years ago. These programs were intended to bring in very good students who may not be participating in the honors program, but certainly are outstanding students and absolutely above average. We're growing the scholars programs and you'll hear a little bit more about that later.

We truly are quite serious in our continuing efforts to make sure there is a diverse student class. We look at that specific population and the international students I've talked about. We talk about in-state and out-of-state and recognize the balance that we'd like to try to keep to make sure this is a top-notch university. We want to go beyond just the State of Ohio.

We have 43 Living-Learning Programs on campus and we identify students by their interest based on residential programs that connect with the academic programs. This year we are continuing and strengthening the discussion about recruiting students for the regional campuses. As we talk about this "One university with many locations," that's given a new emphasis to making sure that students have a sense of where might be the best place for them to start their Ohio State education and to complete it.

Our office is also responsible for transfer students. As we've been changing the profile of the incoming freshman, that is creating conversations about our transfer population that has always been a significant part. Almost one out of three of our graduates are still students who did not begin at Ohio State, and so we look at that group of students and what that means for this recruitment funnel. This is how we start it: 1) we talk about prospects -- students who would be a good match for Ohio State; 2) inquiries -- students who actually say, "Yes, I'd like to hear more about Ohio State;" 3) applicants -- students who complete that application; 4) those students we then admit -- students who pay their deposit and say, "I'm coming;" 5) finally, we get down to students who actually enroll.

This used to be a simple process, we knew who we were talking about. If you look at this cartoon -- one of my favorite cartoon strips happens to have an unfortunate name, "Zits." Jeremy is a very bright 16-year-old and fairly typical of today's young person. When his mom accuses him of being unreasonable, he notes that, "Hey, all I want is what I want when I want it," and goes off to his computer wondering, "Why can't the rest of the world be more like you?"

**FIRST YEAR EXPERIENCE/RECRUITMENT AND RETENTION STRATEGIES/
NEW UNDERGRADUATE STUDENT PROFILES (contd)**

Dr. Freeman: (contd)

The introduction of the Web has really had an impact on college admissions, because students can learn a lot about us without us ever knowing that they're learning about us. In the old days, they had to send a card in saying, "Would you please tell me something about Ohio State?" and you could track your students. We know that thousands and thousands of students are out there -- 9th, 10th, and 11th graders, looking at websites. They are doing their own early review of materials and it's added a new dimension to our undergraduate recruiting efforts.

If you want to talk big numbers, we'd like to share with you a few. For last year's freshman class, we dealt with 192,400 prospects at the beginning of this funnel, of which 85,000 of those students say to us, "We'd like to keep talking to you about Ohio State." Over 20,000 of those students will apply for fall quarter. We will admit between 14,000 and 14,500 in order to end up with a class this fall, we hope, of 5,980 students. We're going to look for a few more students for this fall because of the change in the selective admissions to all four quarters. If you look at that sequence and realize that we come in 30 students over the targeted goal, it is remarkable. It is why all of these people that are sitting around me deserve every bit of credit that can be given to them. There are many corporations who would like to come in as close to the target as we do in Admissions.

I'd like Allen to take a moment to talk a little bit about this communication process.

Mr. Allen D. Kraus:

Thank you, Mabel. Obviously marketing communications is a very big part of what we do in the admissions and recruitment processes. I want to talk just for a minute about our processes for developing and distributing these materials.

We develop communications that we distribute across media. There is a lot of direct mail that we do to some of the students toward the top of that funnel whose names we get from traditional sources like ACT, SAT, PSAT, and some others. We do a tremendous amount of direct mail to those students. We have a number of targeted publications that we provide to students, just a small sample of which is in the folders that we gave you. We do a great deal with e-mail. We send a lot of e-mail to students and we have a great deal of web content out there as well. So there are a number of ways that we attempt to communicate with students.

We partner with University Marketing Communications to work on many of the things to conceive and develop these communications so that we can ensure a consistent message and high quality across our communications. Given Dr. Holbrook's remarks, it is definitely worth mentioning that our size is part of our message that we are trying to deliver in all of these communications. The last thing that we are trying to do is apologize for being big, but, rather, we put an emphasis on the strengths of the University associated with its size.

I want to mention a couple of the samples that are in your folder. Our main piece is the publication we refer to as "Book One." This is the application bulletin and view book, in which we attempt to summarize all the academic and co-curricular benefits of the University. It also contains application materials. Also, there is a publication describing the services offered to minority students by the Office of Minority Affairs, and an application in that publication for the minority scholars program. Also in the folder we have samples of some postcards that were

**FIRST YEAR EXPERIENCE/RECRUITMENT AND RETENTION STRATEGIES/
NEW UNDERGRADUATE STUDENT PROFILES (contd)**

Mr. Kraus: (contd)

developed to highlight specific academic areas. There is a brochure that details merit scholarships, and a brand new one that describes honors opportunities at the University. Again, this is a just a sample, but we wanted you to see some of the things that we do.

Dr. Freeman:

Thank you, Allen. In addition to communications, we also need to get face-to-face with these students in as many ways as possible. Jefferson Blackburn-Smith, senior associate director, is going to talk a little bit about the outreach efforts, because that is particularly under his tutelage.

Mr. Jefferson R. Blackburn-Smith:

With the outreach efforts, one of the things that we really try to do is be very strategic with our resources. When we're looking at 85,000 students who've told us they might want to come to Ohio State in any given year, it becomes very difficult to have personal, meaningful conversations and dialogues with all of these students. So we really try to put ourselves in situations strategically where we are communicating personally and individually with the students that are most likely to enroll and make good decisions. So I want to talk briefly about a couple of things that we think are key in reaching our goals.

One thing I'd like to talk about is the top 300 group. We do operate under a system of territory management, where our outreach people have a geographic territory in Ohio or out of state that they're responsible for. Some of these territories – Columbus area, which is Columbus and Central Ohio, for example – will have over 8,000 students who have inquired. So it becomes very difficult to have, again, those personal relationships that make a difference.

What we have done is select the top 300 students that meet our academic goals and that we find most desirable in that territory. Then the territory manager will do additional personal efforts with those students such as notes, birthday cards, phone calls, and conversations with parents. We have special visit opportunities for those students. We take them to lunch and we host small receptions and dinners in their cities for them. Again, to have real personal contact with these students to help them understand the benefits of Ohio State for them.

Another event I'd like to point out is the engineering reception that we offer in Cincinnati. Again, due to competition from the University of Cincinnati for engineering students, specifically students in that region of the state, this is strategically planned to meet the needs that we find. We take over 30 faculty and staff to Cincinnati, we invite all the students in the Cincinnati region who are interested in engineering, and have a wonderful evening of conversation about the benefits of the Ohio State engineering program. We really highlight the differences in our co-op and internship program from what they've heard from the University of Cincinnati. It has been a marvelous tool for us to make great inroads in the City of Cincinnati against another very strong engineering program.

We also do a lot related to National Merit students, and then yield receptions throughout the state and in key out-of-state targets for students who have been admitted. We also do a number of things to provide our interested students with as many opportunities as possible to visit campus and learn first-hand what Ohio State has to offer. This Autumn Quarter alone, we have 11 open houses planned with anywhere from 250 to 300 guests at each open house.

**FIRST YEAR EXPERIENCE/RECRUITMENT AND RETENTION STRATEGIES/
NEW UNDERGRADUATE STUDENT PROFILES (contd)**

Mr. Blackburn-Smith: (contd)

Today is a very special event -- the Ohio State Honors Day. We have over 250 of Ohio's brightest high school seniors on campus with their parents attending a special conference-style visit event. They are selecting from over 40 sessions to attend, that cover everything from merit scholarship information to the benefits of the honors program. We have 10 faculty that are offering academic sessions that tie their research to current event situations. For example, topics like: "The War on Terror," "A Rhetorical Analysis of Mass Media," and "Physics in your Face – Batteries, Grapes, and CDs." These students are all either National Merit and Achievement semi-finalists or they are students who have scored at least 30 on the ACT. They are Ohio's brightest students. It is a wonderful day. The energy in the room this morning was fabulous and we will have a very positive outcome from this event.

Another event that is coming up that we're very excited about is the Merit Scholarship Preview Day. This is an event that is being jointly sponsored by the Office of Minority Affairs, Undergraduate Admissions, and the Honors and Scholars Center. We will be bringing the brightest minority students from across the State of Ohio to campus. Again, to learn about the opportunities that Ohio State has to offer them, academically with scholarship and financial aid information, and support services. This will be happening in early December. We really do feel these opportunities to bring students on campus and introduce them to our faculty and staff, make a huge strategic difference in who we recruit.

Dr. Freeman:

We can do all of this, but then we also realize that there are things that can pop up that can challenge us on getting to our goals. One of the things that we introduced in this year's application is a strongly encouraged, but not yet required, optional essay question. We've never done that at Ohio State. All of the research shows that as soon as you introduce an essay question, your number of applications will go down. The number of applications will come back up two to three years later, and they'll come back as a stronger group of students. But there will be students who will choose not to apply now because they think, "The only way I'm going to get in is if I write that essay, and I don't want to write that essay."

Whether it's the University of Michigan that had the phenomena or Ohio State, the reality is we know, and we're trying to anticipate that. But we also believe the essay is really critical, because our essay question is not one they can take off the web. The answer is really about themselves, and trying to make that match with the student and the University. We're particularly introducing this because of the potential of what might happen as far as creating a diverse class. If we cannot have a direct identification of students as to what diversity they will bring to the class, the pending 6th Circuit Court decision on the University of Michigan case will obviously have a direct effect on Ohio State. Yesterday there was a meeting in Atlanta with many of the publics and much of the time was spent talking about the current legal situation and anybody's guess is as legitimate right now as anyone else's as to how this is going to come out. But we need to be prepared at Ohio State if we are going to need to make changes in our admissions process.

Tuition decisions can also have an impact on what the class will be. The whole University gets involved in trying to make the best decision regarding tuition and we're very aware of other universities as well. In the meeting I was at yesterday,

**FIRST YEAR EXPERIENCE/RECRUITMENT AND RETENTION STRATEGIES/
NEW UNDERGRADUATE STUDENT PROFILES (contd)**

Dr. Freeman: (contd)

the University of Virginia was indicating they're going to put a mid-year surcharge in this coming month. Surcharges are now becoming quite prevalent. There were some other publics that were saying they're doing the same thing. So we know that this is a challenge particularly for public universities right now.

Academic reputation is an interesting challenge. We review the students who we admit, but don't attend, as well as research the students who do come, as to why they do come. The number one reason why a student chooses to go someplace else is the academic major that they could pursue at another institution. The number one reason why students choose to come to Ohio State is the academic major they can pursue at Ohio State. Those two are not in conflict with each other. What that is saying is that when we are talking about recruiting this type of student now at Ohio State, they are really zoning in on, "What does that major mean for me?" The information they can get about that major and whether that's going to be a department where they're going to feel comfortable is critically important.

We met two weeks ago with the deans, associate deans, and several department chairs from campus and gave a similar presentation to make sure that they too are aware of how critically important this information about their departments really is for today's student. It is not just about the University. So these are factors that can affect admissions and we pay attention to them.

The good news is that once we get the students here, it is then all about keeping them. This chart shows retention rates and what is happening with retention. Students will not graduate if we can't get them from the first to the second to the third to the fourth year. We did go up a little bit this year in first-year retention. All of you know, that we'd like to get 90 percent of students coming back from the first to the second year. It might interest you to know that nationally only 75 percent of all students return from the first year to the second year. So clearly, at 86.5 percent, we are doing very well, but we'd like to get that up to 90 percent.

The biggest jumps this year came in the retention from the second to the third year, going from 75.8 percent up to 79 percent, and then from third to fourth year, 66 percent up to 70.8 percent. These are all jumps that are going to begin to have an impact on that six-year graduation rate. This year that, too, went up, strongly compared to the previous year -- from 56 percent to 58.8 percent. So we're closing in on that 60 percent and clearly want to get beyond that.

We believe the creation of the First Year Experience Program will pay particular attention to making sure that students are coming in and having that experience that all of us in this room know that is possible for a student. At orientation this summer, we said to all of the students and parents that three things are going to be particularly important that have not a lot to do with their specific major, but a lot to do with their feeling like this is the right place for me to be. One is simply learning to navigate Ohio State. We are big, we are complex, and we are challenging, and we are telling students that. But we are telling them that is the joy, then, of having a university that also can provide the range of opportunities we have. That means knowing where the resources are for help on this campus, and knowing how to manage the distractions and manage their independence on a campus like Ohio State. We say these messages now to the students and parents because this is really a three-way partnership. It is family, students, and the University.

**FIRST YEAR EXPERIENCE/RECRUITMENT AND RETENTION STRATEGIES/
NEW UNDERGRADUATE STUDENT PROFILES (contd)**

Dr. Freeman: (contd)

We want the students to get in the conversation and we know that the best universities have an intellectual and stimulating environment. That means really getting in there as a freshman and learning to debate and to question. Find out what you can add to this community and to recognize who you are, what you believe in, how that might differ from the next person, and how that is really good, and that it might be different from the next person sitting right across from you.

Then we also talk about traditions and becoming a Buckeye, and what it means to embrace the history and traditions of a great university. We believe that is a unique aspect about The Ohio State University. This, too, is a collaborative effort among Academic Affairs and Student Affairs, and it means having all of these groups on the same page about the importance of the first year.

Last year and, again, this year, Alan Kalish is working with a group of faculty to talk about what is different perhaps about teaching freshmen now, compared to when many of our faculty were freshmen, and how can we change what that educational experience might be in the classroom. The academic advisor's role has become even more critical as we've really moved to a direct enrollment pattern on this campus. Academic advisors have new levels of commitment to serving these first-year students.

We have the Living-Learning Programs, the Counseling Center, the Younkin Success Center and all of its study skills help, and the Office of Student Financial Aid giving the message to students it is not just about the aid we give you before you get here, we want to work with you while you are here to make sure that we're not going to lose students because they can't afford to stay. And we became one office -- combining Admissions, Orientation, and the First Year Experience -- so that there would be a consistency and an awareness among students and families that we are involved with them from high school right on through the end of that first year.

As we've mentioned, communication is so important. The more students know about what to expect, the more comfortable they are when they get here, the more successful their transition will be. This summer, the College of Engineering created a new approach between the time of orientation and the beginning of school. They put their students in chat rooms trying to connect them to engineering by making them familiar with each other, as well as some aspects of engineering in the months of August and September, before they even arrived. Arts and Sciences did some targeted e-mailing to their freshmen. Again, in that month before they came to make them already feel part of what they were going to be experiencing once they got here.

We do a whole series of e-mails to at-risk students. These are students who have self-identified through the ACT information that they'd like more help in math or their writing skills aren't as strong as they'd like them to be. They're worried about this and that. We're giving them targeted suggestions and connecting them to the different resource units on campus, because we know that no matter how good the class gets, there is always somebody who's still at risk compared to the rest of the class, and that's an important group of students to be following.

In the summer we introduced students to the concept of the Buckeye Book Community. This year our two authors were: Julia Alvarez, who wrote *In The Time of the Butterflies*; and Michael Chabon, who wrote the Pulitzer Prize-winning *The Amazing Adventures of Kavalier and Clay*. We had close to 4,000

**FIRST YEAR EXPERIENCE/RECRUITMENT AND RETENTION STRATEGIES/
NEW UNDERGRADUATE STUDENT PROFILES (contd)**

Dr. Freeman: (contd)

students buy a book at orientation, and indicate to us that they would read something and come back in the fall prepared to be part of small groups with faculty, and then in large groups when both authors came to campus in October. A lot of universities now are doing summer reading programs, but we don't believe any university the size of Ohio State is working toward getting all of the freshmen participating in this experience.

Then it was time for convocation. They actually arrived! As you can see, convocation fills St. John Arena and it is a wonderful event filled with spirit. This year it was filled with two presidents: President Jennings and President Holbrook. Something we did this last year -- and it went over so well we did it again -- is every student received a scarlet and gray tassel like the one I'm holding up here. We gave them these tassels not to wear on their mortarboard when they graduate -- because there is no college for which these are the official colors -- but to have this tassel in their dorm rooms, hanging on their computer or bedpost, in front of them for the next few years, reminding themselves that this is what it's all about -- graduating from The Ohio State University.

Every student got a "Block O" pin to recognize the tradition that's part of Ohio State and to wear it with pride. And, every student -- thanks to the President Club's steering committee and Dick Wells, particularly -- received a disposable camera. We said to the students, "Start taking pictures, we want you to start photographing your Ohio State experience and connecting with this University." All of a sudden cameras started flashing all over St. John Arena, and it was wonderful. This is being part of a community. This makes this University have a sense of realness, if there is such a word, for these new students.

Then Presidents Holbrook and Jennings led us into the football stadium, around the edge of the stadium, and over to the Oval afterwards for the President's Picnic. Some of the best pictures were the young men -- who were not about to take a picture in St. John Arena because that wasn't cool -- but as they walked down into the stadium, many of these guys handed their cameras to each other and ran for a second onto the field, posed in the Heisman position, had that picture taken, and then ran back into line. There was a wonderful spirit among these students during convocation.

We have created more than 140 programs, and in your packets are the brochures describing the First Year Success Series. These are seminars being taught by the experts on campus on everything from how to stop smoking, to how to make sure you don't get into credit card debt, to overcoming test anxiety, to study skills, to leadership development. At the end of these one-hour programs, the students are to write a one-minute reflection paper that they turn in and will go back to their academic advisors. Thousands and thousands and thousands of these papers are being turned back in.

Students register on the web for these sessions, which are filled. What they're telling us in those one-minute reflections is a lot about why this is an important topic to them, why they need to work on this, and could they have some help on this. They go to these sessions as part of their survey course commitment and they pick the ones that are really important to them. It is a program that has had tremendous success last year and, again, this year.

In addition, we mentioned the Living-Learning communities. They were ranked 18th in the nation by *U.S. News and World Report* and we think that's darn

**FIRST YEAR EXPERIENCE/RECRUITMENT AND RETENTION STRATEGIES/
NEW UNDERGRADUATE STUDENT PROFILES (contd)**

Dr. Freeman: (contd)

impressive. This is the first year they did a ranking about living-learning programs and we were very proud of that. Also, we created cultural arts packets filled with \$5 tickets for students to go downtown and see BalletMet, hear the symphony, or go to a play. We want them to connect with Columbus.

We are into the residence halls to see how their life is going -- dorm-storming we call it. We are putting together the Distinguished Lecture Series this coming spring and bringing in a well-known speaker, particularly to make sure the freshmen are there. The faculty seminars that I mentioned earlier that Alan Kalish is leading to make sure the faculty are also invested in the students in their freshman teaching.

For all of these efforts, the First Year Success Series has been identified as one of the best practices among research universities for first-year programs, as has our engineering first-year program, and we're rather proud of this fact. We'll take it any day when *U.S. News and World Report* would like to suggest we have the 7th best FYE program in the country. So we had a little celebration about that.

It's actually all about the students themselves. We have two honest-to-gosh real live freshmen here to tell you of their first few weeks of their first quarter of their first year at Ohio State has been about. First, I'd like to introduce Elena Pollack. To show you how honest and candid we are, Elena is from Ann Arbor, Michigan, not that that had any effect on why we wanted to make sure she was here today. Elena is an engineering student in the honors program. Elena --

Ms. Elena C. Pollack:

Hi. Up until the last week in June, I was enrolled at the University of Texas--Austin. I had my classes scheduled and was all ready to go to Texas, but something wasn't right. I knew that I was excited to go to college, but there was just something missing. I told my parents and they said, "You're just getting cold feet." I said, "No, seriously." I decided to come to The Ohio State University instead. They were pretty surprised.

The reason I chose to come to The Ohio State University instead of Texas was because of the diverse student body and all of the people who work here. Every time I came to visit -- I visited about seven times this summer -- I met at least three new faces who had open arms and were willing to stop everything they were doing, show me around the campus, and answer any questions I had. They were very warm and welcoming, and it was very comforting. I knew that if I came here, I would be accepted for whom I am. It's everything I've ever wanted in a university. I have met so many new people, I have made so many new relationships in five weeks, and I've learned so much about different cultures, different students, and different backgrounds.

Some of the experiences I've had in the first five weeks have been: working as an OWL. I came a couple days before everyone else and helped others move in, and so far that has been one of the best experiences of my life. I met so many new students, I learned my way around the University fast, and then taught others about how to get around. I met a lot of people who were support systems for me; a network of friends and mentors, and it was a lot of fun.

The second experience was the book experience. I was introduced to Julia Alvarez and that was a once-in-a-lifetime experience that I will never forget. I hold it dear in my heart because her books have had such a strong influence on

**FIRST YEAR EXPERIENCE/RECRUITMENT AND RETENTION STRATEGIES/
NEW UNDERGRADUATE STUDENT PROFILES (contd)**

Ms. Pollack: (contd)

my life. I was adopted from Mexico, and her next book is actually about a girl who is adopted from a Spanish-speaking country and goes to the United States and learns about her identity. This is something I had trouble with growing up, but coming here and meeting her was the turning point in that difficult situation that I've dealt with. I got to ask her a lot of different questions that I've always been wanting to ask people and never really got answers until I talked to her. It was very touching.

I am involved in crew and that is a home away from home – I have a family there. It's a place to go and clear my thoughts. It's a wonderful organization and without it, I don't think I would be as happy as I am right now. My coaches are also mentors and I've made lifelong friendships.

I'm an honors student in the engineering program. Engineering was extremely intimidating because I am a woman. I now know all five girls in all of my three classes of engineering. I was nervous about going in, but the engineering program has made a strong effort to unite the women in engineering. There was a Women in Engineering program over the summer where you go for a week and meet people, but I didn't get a chance to go because I thought I was going to Texas. So I missed out on that, but I've made strong connections with the women in my classes that I have.

My Engineering 100H class is a survey class and I love it because it's teaching me a lot about the different types of engineering. I was undecided and now I've chosen to go into mechanical engineering. The Engineering 100H program introduced me to all of the different aspects and types of engineering. It also has been helpful to me in developing time management skills, learning how to survive at the University, how to get through classes, and what to do to get A's. It's a great support system. I love my instructor.

The other class that I was extremely scared to go to was my English class. I hated English in middle school and high school, I was all about math and science. My English 110 class has altered my view on English and writing papers. My teacher, Mr. John Moe, has an awesome name, but he's also a really cool instructor. He believes that there is no wrong or right way to write, it is about how you feel and your ideas, and as long as you get your point across, you're doing okay. My teachers in high school said that there's only one way to write and that was their way. I could never get above a C on any paper, and I was really frustrated. So, going to English 110 has really changed my idea of writing. I've gotten a lot more confident in my writing skills.

The main thing that I have learned about The Ohio State University in these first five weeks was that even though it is a huge University and there are thousands of students all over the place, I have managed to make it small. I have managed to create relationships and small families through crew, engineering, the women in engineering, and my teachers. I am extremely comfortable and very happy here. I'm more happy than I ever thought I could be, and I know that I made the right decision coming here instead of going to the University of Texas.

Dr. Freeman:

Our other freshman is Brennan Stonerock, from Chillicothe, Ohio. Brennan is a member of the health science scholars program and a pre-med student at Ohio State. Brennan --

**FIRST YEAR EXPERIENCE/RECRUITMENT AND RETENTION STRATEGIES/
NEW UNDERGRADUATE STUDENT PROFILES (contd)**

Mr. Brennan S. Stonerock:

Thanks. It is an honor to be here and thank you for having us. I am a little different in that Ohio State has always been my first choice for college, ever since I was five-years-old. As a child, I had the Buckeyes mock football uniform with the helmet and the pads, and I'd play with my cousins in the backyard.

About my junior year, I received letters from the orientation offices and learned that Ohio State has a very good academic reputation. Also, I wanted to be a doctor and it had a very good med school. There are so many opportunities for volunteer work and for research opportunities, and medical schools look highly at these. This is something that was a big decision for me in choosing Ohio State.

Since I've been here, most of my time has been spent studying, but I have had some free time. I got a job on campus working at Larkins Hall as a volleyball referee, and I joined Alpha Epsilon Delta, which is the pre-med society, and the philosophy club.

As Dr. Freeman said, I am in the health sciences scholars program. I think that's great and it was another huge decision for me. I had applied to other schools, but none of them really offered anything to describe all the different medical fields because I didn't know what kind of doctor I wanted to be. But the health sciences overview has all the medical fields – you name it and it's in there – and we have presentations from the allied med fields and other med fields. I decided to major in circulation technology, which is actually an allied medical profession.

As Dr. Holbrook was saying, this University is huge. But the First Year Experience Program and orientation makes it small. I was also an OWL and that made it small. I'm in the scholars program and that makes it small. It is also big and one of the good things about that are the hospitals. You can experience so many different things. I was riding across the Oval a couple of weeks ago and I saw anti-abortion messages. Now whether or not that's good or bad, you can see it and experience it, along with so many things at this University that you wouldn't be able to at a smaller university.

My professors, my TA's, and my health sciences leader have all been helpful. My health sciences leader, Lisa Harchalk, is great. She has been like my mom. She helps me do anything. She helped me pick my major and convinced me what I want to do with the rest of my life. It has been great. Everybody here has been very helpful. I'm very proud to be here. I'm excited and I look forward to the next three years.

Dr. Freeman:

Thank you for letting us share this with you today. I don't know if you have any time left for questions, because we had a lot to say.

Mr. Patterson:

We want to thank all of you for the time and effort that you've put in on this presentation. When everything is all said and done, the reason that we're all here and the reason that we exist are for the students and their success. To hear their presentation this morning, I find, and I'm sure the Board does, extremely informative. I thank you for all that you did.

**FIRST-YEAR EXPERIENCE/RECRUITMENT AND RETENTION STRATEGIES/
NEW UNDERGRADUATE STUDENT PROFILES (contd)**

Dr. Freeman:

We appreciate that and we'd like to ask you to help us, too. We have something for each of the Board members. It's not for you personally, but we give these to students as we are talking to them about coming to Ohio State. They are Ohio State laundry bags, and we're willing to have students come with their laundry. We thought that you might know someone in your neighborhood, it could be a relative or a friend, but we would be delighted if you would pass on an Ohio State laundry bag to a potential Ohio State University Buckeye. Tell them that not only do we want them to come and be a student, we want them to come and live with us and experience Ohio State University in all ways possible.

Thank you, again, for letting us be here this morning

--0--

CONSENT AGENDA

President Karen A. Holbrook:

We have eleven resolutions on the Consent Agenda today and unless there are any objections, I would like to recommend the following resolutions to the Board:

REGIONAL CAMPUS BOARD APPOINTMENT

Resolution No. 2003-49

Synopsis: Approval of an appointment to The Ohio State University Regional Campus Board is proposed.

WHEREAS the Board of Trustees in 1994 approved the establishment of The Ohio State University Regional Campus Boards; and

WHEREAS it has been previously stipulated that "the board shall be composed of eleven members appointed by The Ohio State University Board of Trustees in consultation with the president of the university" (one member of the board shall be a member of the university board of trustees; nine members shall be private citizens; and one member shall be a student); and

WHEREAS the following named person has been nominated and selected for appointment to the following Regional Campus Board for the term as specified:

Lima Board Student Appointment

Stephanie Patton, 1-year term

NOW THEREFORE

BE IT RESOLVED, That the foregoing nominee be approved as a member of The Ohio State University-Lima Board, effective July 1, 2002.

**CREATION OF THE WILLIAM E. KIRWAN INSTITUTE FOR THE
STUDY OF RACE AND ETHNICITY IN THE AMERICAS**

Resolution No. 2003-50

Synopsis: Approval of the creation of The William E. Kirwan Institute for the Study of Race and Ethnicity in the Americas is proposed.

WHEREAS the College of Humanities, the Moritz College of Law, and the College of Social and Behavioral Sciences, have worked collaboratively over several years to establish the proposed Institute; and

WHEREAS the proposed Institute will be a distinctive interdisciplinary research Institute that embraces race and ethnicity and examines these concepts throughout the Americas; and

WHEREAS the proposed Institute's mission supports both the University's Academic Plan and the Diversity Plan; and

WHEREAS the proposal satisfies the guidelines for the establishment and review of academic centers (3335-3-36), including membership, administration, budget, and evaluation; and has been endorsed strongly through letters of support, and campus visits and comments from external scholars; and

WHEREAS on June 7, 2002 the Board of Trustees named the proposed Institute "The William E. Kirwan Institute for the Study of Race and Ethnicity in the Americas"; and

WHEREAS the proposal was discussed and approved by the Research Committee, the Research and Graduate Council, and the reviewing subcommittee, the Council on Academic Affairs, and by the University Senate at its October 10, 2002 meeting:

NOW THEREFORE

BE IT RESOLVED, That the creation of The William E. Kirwan Institute for the Study of Race and Ethnicity in the Americas is hereby approved, effective immediately.

NAMING OF LAW AUDITORIUM

Resolution No. 2003-51

Synopsis: Naming of the auditorium located in John Deaver Drinko Hall at the Michael E. Moritz College of Law, 55 West 12th Avenue, is proposed.

WHEREAS William B. Saxbe, a Mechanicsburg, Ohio, resident is a 1948 graduate of the College of Law who devoted his life to a distinguished career in public service; and

WHEREAS his career in public service dates back to his being elected to the Ohio House of Representatives in 1946 at the age of 29, serving four terms in the Ohio House, and serving three terms as Ohio Attorney General; and

WHEREAS William B. Saxbe was a United States Senator before being appointed U.S. Attorney General, considered one of the highest public service posts in the legal profession and was appointed Ambassador to India in 1975 and served until 1977; and

WHEREAS his career exemplifies the integrity and dedication to serving the nation that is instilled in students at the Moritz College of Law; and

NAMING OF LAW AUDITORIUM (contd)

WHEREAS William B. Saxbe continues to serve his alma mater through his volunteer leadership and his generosity:

NOW THEREFORE

BE IT RESOLVED, That in accordance with paragraph (F) of rule 3335-1-08 of the Administrative Code, the aforementioned facility shall be named the "William B. Saxbe Auditorium" at The Ohio State University's Michael E. Moritz College of Law.

PERSONNEL ACTIONS

Resolution No. 2003-52

BE IT RESOLVED, That the personnel actions as recorded in the Personnel Budget Records of the University since the October 4, 2002 meeting of the Board, including the following Promotion, Reappointment, Professional Improvement Leave, Professional Improvement Leaves—Change in Dates, and Emeritus Title as detailed in the University Budget be approved.

Promotion

Name: KAMILLA K. SIGAFOOS
Title: Executive Director
Hospitals: University Hospitals
Effective: November 1, 2002
Concurrent Appointment: Associate Vice President for Health Services

Reappointment

Name: GLENN S. DAEHN
Title: Professor (The Dr. Mars G. Fontana Professorship in Metallurgical Engineering)
College: Engineering
Term: October 1, 2002, through June 30, 2003

Professional Improvement Leave

RICHARD E. BOETTCHER, Professor, College of Social Work, effective Autumn Quarter 2003.

Professional Improvement Leaves—Change in Dates

ANTHONY MUGHAN, Professor, Department of Political Science, change leave from Winter Quarter 2003, to Spring Quarter 2003.

ANTON F. SCHENK, Professor, Department of Civil and Environmental Engineering and Geodetic Science, change leave from Autumn Quarter 2002, Winter Quarter and Spring Quarter 2003, to Autumn Quarter 2003, Winter Quarter and Spring Quarter 2004.

Emeritus Title

GEORGE W. WAYLONIS, Department of Physical Medicine and Rehabilitation, with the title Clinical Professor Emeritus, effective November 1, 2002.

RESOLUTIONS IN MEMORIAM

Resolution No. 2003-53

Synopsis: Approval of Resolutions in Memoriam is proposed.

RESOLVED, That the Board adopt the following Resolutions in Memoriam and that the President be requested to convey a copy to the families of the deceased.

Robert H. Bremner

The Board of Trustees of The Ohio State University expresses its sorrow upon the death on September 7, 2002, of Robert H. Bremner, Professor Emeritus in the Department of History.

Professor Bremner held a Bachelor of Arts degree from Baldwin Wallace College and a Master of Arts and Doctor of Philosophy degrees from The Ohio State University. After working in the War Department and holding an appointment as associate historian of the American Red Cross, Professor Bremner joined the History faculty at Ohio State in 1946, where he taught until his retirement in 1980. He also held visiting appointments at the Universities of Wisconsin, Montana, Cincinnati, and Michigan. Professor Bremner published widely in the field of modern U.S. history and won recognition for his studies of American attitudes towards poverty, the history of philanthropy and social welfare, and public policy towards children and youth in the United States. Among his most notable books are: *From the Depths: The Discovery of Poverty in the United States* (1956), *American Philanthropy* (1960), and *The Public Good, Philanthropy and Welfare in the Civil War Era* (1980).

Robert Bremner also won numerous grants, fellowships, and awards to support his scholarship. He was the recipient of awards from the North Atlantic Treaty Organization, the Huntington Library, the Social Sciences Research Council, the Rockefeller Foundation, the National Endowment for the Humanities, and the Charles Warren Center at Harvard University. At Ohio State, he received the Alumni Award for Distinguished Teaching and the Joseph Sullivant Medal. Professor Bremner also won the Alumni Distinguished Service Award of the Ohio Academy of History.

Professor Bremner served his profession and the community at the highest level. He was president of the Ohio Academy of History, chairman of the Social Welfare History Group, and a member of the editorial board of the *American Historical Review*. Professor Bremner also served on the President's Science Advisory Committee (Panel on Youth) and on the National Academy of Science's Panel on Federal Programs for Youth.

Robert Bremner was an active member of department, college, and University committees over his long tenure at Ohio State. A devoted and much respected undergraduate and graduate teacher, Professor Bremner served as the director for 40 students who received the Ph.D. degree in History at Ohio State.

On behalf of the University community, the Board of Trustees expresses to the family of Professor Robert H. Bremner its deepest sympathy and understanding of their loss. It was directed that this resolution be inscribed upon the minutes of the Board of Trustees and that a copy be tendered to his family as an expression of the Board's heartfelt sympathy.

Edward "Ted" Coates

The Board of Trustees of The Ohio State University expresses its sorrow upon the death on September 16, 2002, of Ted Coates, Associate Professor Emeritus of Sport Management in the School of Health, Physical Education, and Recreation (now named the School of Physical Activity and Educational Services).

RESOLUTIONS IN MEMORIAM (contd)

Edward "Ted" Coates (contd)

Dr. Coates received his bachelor's degree from Cortland College where he earned varsity letters in basketball, baseball, and soccer. Dr. Coates received his master's degree from Columbia University Teacher's College in 1947. He then began his career as a teacher and joined the faculty at Royalton-Hartland Central School in Middleport, New York. He enrolled at Ohio State in 1963 to pursue his Ph.D. and worked as an instructor. He earned his doctorate in 1966 and remained at Ohio State where he was an enthusiastic and dedicated teacher.

Professor Coates is credited with establishing the sport management program at Ohio State. He was an innovator and visionary for his time. Dr. Coates noticed the need for a sport management program and, in the fall of 1975, Ohio State joined a select group of universities to offer a master's degree in sport management. Eight students began the program under the direction of Dr. Coates. Since that time, more than 600 students have graduated from the program. Dr. Coates' legacy is seen each and every day, with the OSU graduates significantly influencing the sporting world.

Serving the profession at the highest level, Professor Coates was the chair of the American Alliance for Health, Physical Education, Recreation, and Dance's Council of Facilities and Equipment. Dr. Coates's area of expertise was in facility management. He published a widely praised text on facility planning. Prior to retiring and because of his expertise, Dr. Coates helped the University of California – Fullerton, redesign its sport management program.

On behalf of the University community, the Board of Trustees expresses to the family of Dr. Coates its deepest sympathy and sense of understanding of their loss. It was directed that this resolution be inscribed upon the minutes of the Board of Trustees and that a copy be tendered to his family as an expression of the Board's heartfelt sympathy.

Arnold E. Ross

The Board of Trustees of The Ohio State University expresses its sorrow upon the death on September 25, 2002, of Arnold E. Ross, Professor Emeritus in the Department of Mathematics.

Professor Ross earned his doctorate in mathematics from the University of Chicago in 1931. After serving as head of the Mathematics Department at the University of Notre Dame for many years, Dr. Ross was appointed chairman of the Department of Mathematics at The Ohio State University in 1963, serving in that capacity until his retirement in 1976.

Professor Ross was an able administrator and a dedicated teacher, creating several new courses and programs during his long career. He was deeply interested in teaching, especially with the problems of identifying talented students and engaging them in intellectual pursuits. In the 1960s, he initiated innovative outreach programs (New Horizons and Horizons Unlimited) for inner city school children in Columbus. In the 1970s, he created a new type of honors math course for OSU freshmen. Perhaps his most notable achievement was his summer program for high school students talented in mathematics. It has been highly successful since it began in 1957, and the Ross Mathematics Program continues to thrive at Ohio State. Professor Ross directed and taught in that program every summer until poor health forced him to retire in 2000 at age 94. Alumni of the Ross Program have created similar high school programs at other universities in the United States and Canada.

Professor Ross served his profession of mathematics and education at the highest level. In addition to serving on numerous department, college, and University committees he served on mathematics policy and curriculum committees for the National Science Foundation. He received many recognitions and honors including the OSU Distinguished Teaching Award (1974) and Distinguished Service Award (1981). He was president of the Ohio Section of the Mathematical Association of America (1968-1969) and received the MAA Award for Distinguished Service

RESOLUTIONS IN MEMORIAM (contd)

Arnold E. Ross (contd)

(1986). The American Mathematical Society established the "Arnold Ross Lecture Series" in his honor (1993) and presented him with a Citation for Public Service (1998).

On behalf of the University community, the Board of Trustees expresses to the family of Professor Arnold E. Ross its deepest sympathy and sense of understanding for their loss. It was directed that this resolution be inscribed upon the minutes of the Board of Trustees and that a copy be tendered to his family as an expression of the Board's heartfelt sympathy.

REPORT OF RESEARCH CONTRACTS AND GRANTS

Resolution No. 2003-54

Synopsis: The report on research and other sponsored program contracts and grants and the summary for September 2002 is presented for Board acceptance.

WHEREAS monies are solicited and received on behalf of the University from governmental, industrial, and other agencies in support of research, instructional activities, and service; and

WHEREAS such monies are received through The Ohio State University Research Foundation:

NOW THEREFORE

BE IT RESOLVED, That the research agreement between The Ohio State University and The Ohio State University Research Foundation for the contracts and grants reported herein during the month of September 2002 be approved.

REPORT ON UNIVERSITY DEVELOPMENT

Resolution No. 2003-55

Synopsis: The report on the receipt of gifts and the summary for September 2002 are presented for Board acceptance.

WHEREAS monies are solicited and received on behalf of the University from alumni, industry, and various individuals in support of research, instructional activities, and service; and

WHEREAS such gifts are received through The Ohio State University Development Fund and The Ohio State University Foundation; and

WHEREAS this report includes the establishment of The John G. and Jeanne Bonnet McCoy Chair in The Ohio State University Heart Center; and

WHEREAS this report includes the establishment of thirteen (13) new named endowed funds and the amendment of two (2) named endowed funds:

NOW THEREFORE

BE IT RESOLVED, That the acceptance of the report from The Ohio State University Development Fund and The Ohio State University Foundation during the month of September 2002 be approved.

REPORT ON UNIVERSITY DEVELOPMENT (contd)

TOTAL UNIVERSITY PRIVATE SUPPORT

July through September
2001 Compared to 2002GIFT RECEIPTS BY DONOR TYPE

	Dollars July through September		
	<u>2001</u>	<u>2002</u>	<u>%Change</u>
Individuals:			
Alumni (Current Giving)	\$4,086,507	\$6,870,104	68
Alumni (From Bequests)	<u>1,565,329</u>	<u>1,236,831</u>	(21)
Alumni Total	\$5,651,836	\$8,106,935	43
Non-Alumni (Current Giving)	\$2,916,130	\$3,493,171	20
Non-Alumni (From Bequests)	<u>918,795</u>	<u>2,881,248</u>	214
Non-Alumni Total	\$3,834,925	\$6,374,419	66
Individual Total	\$9,486,761	\$14,481,354	53 ^A
Corporations/Corp/Foundations	\$8,124,136	\$9,220,240	13 ^B
Private Foundations	\$3,102,024	\$1,693,173	(45) ^C
Associations and Other Organizations	<u>\$842,950</u>	<u>\$912,434</u>	8
Total	\$21,555,871	\$26,307,201	22

NOTES

- A Individual giving is up 53% largely due to the fact that gifts of \$10,000 or more are up 100% (88 gifts for \$5.9 million last year; 112 gifts for \$11.8 million this year).
- B Gifts at the \$10,000 or more level from corporations are up 15% for July-September compared with the same period last year (166 gifts for \$6.6 million last year; 172 gifts for \$7.6 million this year).
- C Foundation giving at the \$10,000 or more level is down 45% for the first quarter of the fiscal year (\$1.5 million from 31 gifts this year; \$2.9 million from 38 gifts last year).

REPORT ON UNIVERSITY DEVELOPMENT (contd)

TOTAL UNIVERSITY PRIVATE SUPPORT (contd)

July from September
2001 Compared to 2002

GIFT RECEIPTS BY PURPOSE

	Dollars July through September		
	<u>2001</u>	<u>2002</u>	<u>% Change</u>
Gift Receipts to Current Use and Endowment Funds:			
Buildings/Equipment	\$3,672,627	\$3,789,595	3
Faculty Support	\$519,130	\$2,873,538	456
Program Support	\$12,918,087	\$12,427,903	(4)
Student Financial Aid	\$3,306,078	\$5,403,620	63
Annual Funds-Colleges/Departments	\$1,018,652	\$1,691,914	66
Annual Funds-University	<u>\$121,297</u>	<u>\$120,631</u>	(1)
Total	\$21,555,871	\$26,307,201	22

GIFT ADDITIONS TO ENDOWMENT

Dollars
July through September

<u>2001</u>	<u>2002</u>	<u>% Change</u>
\$5,665,807	\$8,363,947	48

REPORT ON UNIVERSITY DEVELOPMENT (contd)

THE OHIO STATE UNIVERSITY DEVELOPMENT FUND

Change in Description of Named Endowed Funds

The Dr. Edward E. Eddowes Memorial Aviation Psychology Fund
 The Charles E. McKee Memorial Scholarship Fund

THE OHIO STATE UNIVERSITY FOUNDATION

	<u>Previous Gifts</u>	<u>Current Gifts</u>	<u>Total Gifts</u>
<u>Establishment of Named Endowed Chair</u>			
The John G. and Jeanne Bonnet McCoy Chair in The Ohio State University Heart Center (Used to support a faculty member within the OSU Heart Center; provided by gifts from John G. and Jeanne Bonnet McCoy)		\$2,000,308.24	\$2,000,308.24
<u>Establishment of Named Endowed Funds</u>			
The Evelyn Michael MBA Fellowship Fund (Used to provide support to graduate students in the Fisher College of Business; provided by a gift from Timothy A. Michael and Melinda Vogel Michael)		\$253,750.00	\$253,750.00
The Eleanor L. Craig Scholarship Fund (Used to provide a scholarship for an accounting major in the Fisher College of Business; provided by gifts from Eleanor L. Craig)	\$173,605.86		\$173,605.86
The William M. and Darlene Aldrige Agriculture Scholarship Fund (Used to provide scholarships in the College of Food, Agricultural, and Environmental Sciences; provided by gifts from the estate of Darlene Aldrige)	\$150,000.00		\$150,000.00
The George T. Harding III, MD, Endowed Chair in Psychiatry Fund (Used to support a psychiatrist within the Department of Psychiatry; provided by gifts From family and friends of the late George T. Harding III, M.D.)		\$95,004.00	\$95,004.00
The Hershel T. Meredith Endowed Fellowship Fund (Used to supplement tuition, room and board for a post DVM student with an interest in a veterinary research career; provided by a gift from Herschel T. Meredith)		\$90,675.93	\$90,675.93

REPORT ON UNIVERSITY DEVELOPMENT (contd)

THE OHIO STATE UNIVERSITY FOUNDATION (contd)

	<u>Previous Gifts</u>	<u>Current Gifts</u>	<u>Total Gifts</u>
<u>Establishment of Named Endowed Funds (contd)</u>			
The Herschel T. Meredith Women's Athletics Scholarship Fund (Used to provide scholarship costs of undergraduate student athletes who are participating in women's varsity athletics; provided by gifts from Herschel T. Meredith)		\$90,675.93	\$90,675.93
The Suzanne G. and Herschel T. Meredith Diabetes Research Fund (Used to support research in the Division of Endocrinology, Diabetes, and Metabolism Relating to Type I diabetes; provided by a gift from Herschel T. Meredith)		\$90,675.93	\$90,675.93
The Peter E. Mardikian Scholarship Fund (Used to provide undergraduate scholarships to students majoring in marketing or finance in the Fisher College of Business; provided by gifts from family and friends in memory of Mr. Mardikian)		\$52,615.00	\$52,615.00
The Pauline and Jean Wyer Scholarship Fund (Used to provide financial aid scholarships; provided by gifts from the Trust of Edwin H. Ziegfeld)		\$51,181.40	\$51,181.40
The Stephen D. Milligan Family Scholarship Fund (Used to provide scholarship for undergraduate student athletes who are participating on the varsity football team; provided by gifts from Stephen D. Milligan)		\$46,706.00	\$46,706.00
The Lloyd L. and Ilma L. Dowell Family Medicine Fund (Used to support the clinical research, teaching, and patient care activities of the Department of Family Medicine; provided by a gift from Ilma L. Dowell)		\$27,990.00	\$27,990.00
The Phillip Wm. Fisher MBA Fellowship Fund (Used to support a MBA fellowship; provided by gifts from Phillip Wm. Fisher)		\$25,000.00	\$25,000.00
The Oliver E. Hamilton Family Endowed Scholarship Fund (Used to provide scholarships for undergraduate and graduate students at OSU-Marion who are single parents; provided by a gift from Oliver E. Hamilton)		\$25,000.00	\$25,000.00
Total	\$323,605.86	\$2,849,582.43	\$3,173,188.29

REPORT ON UNIVERSITY DEVELOPMENT (contd)

THE OHIO STATE UNIVERSITY DEVELOPMENT FUND

Change in Description of Named Endowed Funds

The Dr. Edward E. Eddowes Memorial Aviation Psychology Fund

The Dr. Edward E. Eddowes Memorial Aviation Psychology Fund was established June 4, 1993, by the Board of Trustees of The Ohio State University with gifts in memory of Dr. Edward E. Eddowes (of Birmingham, Alabama) from his widow, Mrs. E. Anne Eddowes (B.S.Bus.Adm., 1953); his family and friends. The description was revised on November 1, 2002, at the request of Mrs. Eddowes and the dean of the College of Engineering.

All gifts are to be invested in the University's Permanent Endowment Fund, under the rules and regulations adopted by the Board of Trustees of The Ohio State University, with the right to invest and reinvest as occasion dictates.

This memorial recognizes Dr. Edward E. Eddowes' lifelong interest in psychology and its application to aviation.

The annual income shall be used to advance the study of and research in aviation human factors through program support such as materials for undergraduate research projects and travel funds for student paper presentations on research results, and through undergraduate and graduate level scholarships. Faculty in the aviation human factors program will recommend uses for the annual income to the dean of the College of Engineering, who will authorize expenditures. Scholarship decisions will be made in consultation with the Graduate School or the University Committee on Student Financial Aid.

It is the desire of the donors that this fund should benefit the University in perpetuity. If the need for this fund should cease to exist or so diminish as to provide unused income, then another use shall be designated by the Board of Trustees in consultation with the appropriate college dean, department chairperson, or program administrative officer in order to carry out the desire of the donors.

The Charles E. McKee Memorial Scholarship Fund

The Charles E. McKee Memorial Scholarship Fund was established January 13, 1961, by the Board of Trustees of The Ohio State University with gifts from members of the Ohio Contractors Association and other friends of Mr. McKee. The description was revised on November 1, 2002.

All gifts are to be invested in the University's Permanent Endowment Fund, under the rules and regulations adopted by the Board of Trustees of The Ohio State University, with the right to invest and reinvest as occasion dictates.

The annual income shall be used to support a scholarship(s) for a student(s) who is a U.S. citizen and in their 4th or 5th year in the College of Engineering or Graduate School majoring in civil or environmental engineering. Preference should be given to students who have an interest in highway construction or environmental engineering and who are Ohio residents. Selection is to be made by the chairperson of the Department of Civil and Environmental Engineering and Geodetic Science in consultation with the University Committee on Student Financial Aid, based on the student's scholarship, character, and financial need. The scholarship is granted yearly but the same student may receive it for more than one year.

It is the desire of the donors that this fund should benefit the University in perpetuity. If the need for this fund should cease to exist or so diminish as to provide unused income, then another use shall be designated by the Board of Trustees in consultation with the chairperson of the Department of Civil and Environmental Engineering and Geodetic Science in order to carry out the desire of the donors.

REPORT ON UNIVERSITY DEVELOPMENT (contd)

THE OHIO STATE UNIVERSITY FOUNDATION

Establishment of Named Endowed Chair

The John G. and Jeanne Bonnet McCoy Chair
in The Ohio State University Heart Center

The John G. and Jeanne Bonnet McCoy Chair in The Ohio State University Heart Center was established on November 1, 2002, in accordance with the guidelines approved by the Board of Directors of The Ohio State University Foundation, with gifts to the Foundation from John G. and Jeanne Bonnet McCoy, of Columbus, Ohio.

All gifts are to be invested by the Foundation, under the rules and regulations adopted by the Foundation Board of Directors, with the right to invest and reinvest as occasion dictates.

The annual income shall provide for a chair position to exclusively support a faculty member in the College of Medicine and Public Health serving within The Ohio State University Heart Center, with a preference for it being the director of The Richard M. Ross Heart Hospital. The position shall be held by a nationally eminent faculty member as recommended by the senior vice president for Health Sciences and dean of the College of Medicine and Public Health. The activities of the endowed chair holder shall be reviewed no less than every five years by the senior vice president for Health Sciences and dean of the College of Medicine and Public Health to determine compliance with the intent of the donor as well as with the academic and research standards of the University.

The research activities of the chair holder may also be supported, as income permits, to include: research personnel, equipment, supplies, and other necessary expenses of an active researcher involved in quality medical research in the field of cardiology.

It is the desire of the donors that this fund should benefit the University in perpetuity. If the need for this fund should cease to exist or so diminish as to provide unused income, then another use shall be designated by the Board of Trustees in consultation with the senior vice president for Health Sciences and dean of the College of Medicine and Public Health in order to carry out the desire of the donors.

\$2,000,308.24

Establishment of Named Endowed Funds

The Evelyn Michael MBA Fellowship Fund

The Evelyn Michael MBA Fellowship Fund was established on November 1, 2002, in accordance with the guidelines approved by the Board of Directors of The Ohio State University Foundation, with a gift from Timothy A. Michael (B.A., 1970; M.B.A., 1976) and Melinda Vogel Michael (B.S.Ed., cum laude, 1970; M.A., 1975).

All gifts are to be invested by the Foundation, under the rules and regulations adopted by the Foundation's Board of Directors, with the right to invest and reinvest as occasion dictates.

The annual income shall be used to provide support to a graduate student(s) in The Max M. Fisher College of Business. Selection of the recipient(s) shall be made by the dean of the Fisher College of Business with recommendations made by the Fisher College graduate programs director. Special consideration will be given to a graduate student(s) who may add to the overall diversity of the college's graduate program. Fellowships will be awarded in consultation with the University Committee on Student Financial Aid.

REPORT ON UNIVERSITY DEVELOPMENT (contd)

THE OHIO STATE UNIVERSITY FOUNDATION (contd)

Establishment of Named Endowed Funds (contd)

The Evelyn Michael MBA Fellowship Fund (contd)

It is the desire of the donors that this fund should benefit the University in perpetuity. If the need for this fund should cease to exist or diminish as to provide unused income, then another use shall be designated by the Board of Trustees as recommended by the person or unit with spending authority, and/or appropriate University official, in order to carry out the desire of the donors.

\$253,750.00

The Eleanor L. Craig Scholarship Fund

The Eleanor L. Craig Scholarship Fund was established on November 1, 2002, in accordance with the guidelines approved by the Board of Directors of The Ohio State University Foundation, with gifts from Eleanor L. Craig (B.S.Bus.Adm., 1934).

All gifts are to be invested by the Foundation, under the rules and regulations adopted by the Foundation's Board of Directors, with the right to invest and reinvest as occasion dictates.

The annual income shall be used to fund a scholarship for a student enrolled in The Max M. Fisher College of Business who is an accounting major, who has a 3.5 or better grade point average (GPA), and who demonstrates financial need. Selection shall be made by the Fisher College of Business Scholarship Committee in consultation with the University Committee on Student Financial Aid, with formal approval by the dean of the Fisher College of Business.

It is the desire of the donor that this fund should benefit the University in perpetuity. If the need for this fund should cease to exist or so diminish as to provide unused income, then another student-oriented educational use shall be designated by the Foundation Board in consultation with the dean of the Fisher College of Business in order to carry out the desire of the donor.

\$173,605.86

The William M. and Darlene Aldrige Agriculture Scholarship Fund

The William M. and Darlene Aldrige Agriculture Scholarship Fund was established on November 1, 2002, in accordance with the guidelines approved by the Board of Directors of The Ohio State University Foundation, with gifts from the estate of Darlene Aldrige of Hillsboro, Ohio, and in memory of her husband, William M. Aldrige (B.S., 1961).

All gifts are to be invested by the Foundation, under the rules and regulations adopted by the Foundation's Board of Directors, with the right to invest and reinvest as occasion dictates.

The annual income shall be used to support scholarships for students enrolled in the College of Food, Agricultural, and Environmental Sciences. The student recipients must exhibit high moral standards, reside in Highland County, Ohio, and have graduated from a high school in Highland County, Ohio. Annual scholarship recipients shall be selected by the college scholarship committee in consultation with the University Committee on Student Financial Aid.

In any given year that the endowment income is not fully expended, the unused portion should be reinvested in the endowment principal.

REPORT ON UNIVERSITY DEVELOPMENT (contd)

THE OHIO STATE UNIVERSITY FOUNDATION (contd)

Establishment of Named Endowed Funds (contd)

The William M. and Darlene Aldrige Agriculture Scholarship Fund (contd)

It is the desire of the donor that this fund should benefit the University in perpetuity. If the need for this fund should cease to exist or so diminish as to provide unused income, then another use shall be designated by the Foundation Board in consultation with the vice president for Agricultural Administration and University Outreach, and executive dean for Food, Agricultural, and Environmental Sciences, or their successor in order to carry out the desire of the donor.

\$150,000.00

The George T. Harding III, MD, Endowed Chair in Psychiatry Fund

The George T. Harding III, MD, Endowed Chair in Psychiatry Fund was established on November 1, 2002, in accordance with the guidelines approved by the Board of Directors of The Ohio State University Foundation with gifts from family and friends of the late George T. Harding, III, M.D., (Clinical Professor Emeritus in the Department of Psychiatry and retired medical director of Harding Hospital) of Worthington, Ohio.

All gifts are to be invested by the Foundation, under the rules and regulations adopted by the Foundation's Board of Directors, with the right to invest and reinvest as occasion dictates.

The annual income provides funds to support the professional activities of a psychiatrist within the Department of Psychiatry who will engage in clinical treatment and teaching activities, including: creative curriculum development; efficient delivery within the economic system; modeling, mentoring and supervision of medical students and residents; and contributions to the professional literature. The chair holder will provide clinical care, with an emphasis on the provision and teaching of psychotherapy both traditional and innovative, which will embrace a number of domains to include spirituality and ethics.

The chair position shall be held by a faculty member who is nationally recognized for contributions in psychotherapy and whole person care as recommended by the senior vice president for Health Sciences and dean of the College of Medicine and Public Health, in consultation with the chairperson of the Department of Psychiatry. The activities of the holder of the chair shall be reviewed no less than every five years by the senior vice president for Health Sciences and dean of the College of Medicine and Public Health to determine compliance with the intent of the donor as well as the academic and research standards of the University.

In any given year that the endowment income is not fully expended, the unused portion should be reinvested in the endowment principal.

It is the desire of the donors that this fund should benefit the University in perpetuity. If the need for this fund should cease to exist or so diminish as to provide unused income, then another use shall be designated by the Board of Trustees in consultation with the senior vice president for Health Sciences and dean of the College of Medicine and Public Health and the chairperson of the Department of Psychiatry in order to carry out the desire of the donors.

\$95,004.00

REPORT ON UNIVERSITY DEVELOPMENT (contd)

THE OHIO STATE UNIVERSITY FOUNDATION (contd)

Establishment of Named Endowed Funds (contd)

The Herschel T. Meredith Endowed Fellowship Fund

The Herschel T. Meredith Endowed Fellowship Fund was established on November 1, 2002, in accordance with the guidelines approved by the Board of Directors of The Ohio State University Foundation, with a gift from Herschel T. Meredith of Los Altos, California.

All gifts are to be invested by the Foundation, under the rules and regulations adopted by the Foundation's Board of Directors, with the right to invest and reinvest as occasion dictates.

The annual income shall be used to supplement tuition, room, and board for one outstanding post D.V.M. student with an interest in pursuing a veterinary research career that benefits the health and welfare of animals. Recipients will be selected based on financial need by the dean of the College of Veterinary Medicine in consultation with the associate dean for research in the College of Veterinary Medicine and the University Committee on Student Financial Aid.

It is the desire of the donor that this fund should benefit the University in perpetuity. If the need for this fund should cease to exist or so diminish as to provide unused income, then another use shall be designated by the Foundation Board as recommended by the person or unit with spending authority and/or appropriate university official in order to carry out the desire of the donor.

\$90,675.93

The Herschel T. Meredith Women's Athletics Scholarship Fund

The Herschel T. Meredith Women's Athletics Scholarship Fund was established on November 1, 2002, in accordance with the guidelines approved by the Board of Directors of The Ohio State University Foundation, with gifts from Herschel T. Meredith of Los Altos, California.

All gifts are to be invested by the Foundation, under the rules and regulations adopted by the Foundation's Board of Directors, with the right to invest and reinvest as occasion dictates.

The annual income shall be used to provide scholarship costs of student athletes who are pursuing undergraduate degrees at The Ohio State University and participating in women's varsity athletics. Recipients shall be selected by the director of Athletics in consultation with the University Committee on Student Financial Aid.

It is the desire of the donor that this fund should benefit the University in perpetuity. If the need for this fund should cease to exist or so diminish as to provide unused income, then another use shall be designated by the Foundation Board as recommended by the director of Athletics in order to carry out the desire of the donor.

\$90,675.93

The Suzanne G. and Herschel T. Meredith Diabetes Research Fund

The Suzanne G. and Herschel T. Meredith Diabetes Research Fund was established on November 1, 2002, in accordance with the guidelines approved by the Board of Directors of The Ohio State University Foundation, with a gift from Herschel T. Meredith (attended Ohio State, 1931) of Los Altos, California.

REPORT ON UNIVERSITY DEVELOPMENT (contd)

THE OHIO STATE UNIVERSITY FOUNDATION (contd)

Establishment of Named Endowed Funds (contd)

The Suzanne G. and Herschel T. Meredith Diabetes Research Fund (contd)

All gifts are to be invested by the Foundation, under the rules and regulations adopted by the Foundation's Board of Directors, with the right to invest and reinvest as occasion dictates.

The annual income shall be used to support research relating to the prevention, treatment, and cure of Type I diabetes, to include both basic and clinical research. The income may support, but is not limited to scientific supplies, laboratory space, equipment, salaries for research personnel, and activities required for high quality medical research in the Division of Endocrinology, Diabetes, and Metabolism.

It is the desire of the donor that this fund should benefit the University in perpetuity. If the need for this fund should cease to exist or so diminish as to provide unused income, then another use shall be designated by the Foundation Board in consultation with the senior vice president for Health Sciences and dean of the College of Medicine and Public Health and director of the Division of Endocrinology, Diabetes, and Metabolism in order to carry out the desire of the donor.

\$90,675.93

The Peter E. Mardikian Scholarship Fund

The Peter E. Mardikian Scholarship Fund was established on November 1, 2002, in accordance with the guidelines approved by the Board of Directors of The Ohio State University Foundation, with gifts from family and friends in honor and memory of Peter E. Mardikian (B.S.Bus.Adm., 1995) who lost his life at the World Trade Center in the tragic events of September 11, 2001.

All gifts are to be invested by the Foundation, under the rules and regulations adopted by the Foundation's Board of Directors, with the right to invest and reinvest as occasion dictates.

The annual income shall be used to provide undergraduate scholarship(s) to students enrolled in The Max M. Fisher College of Business with preference given to students majoring in marketing or finance. Scholarships will be awarded in consultation with the University Committee on Student Financial Aid.

It is the desire of the donors that this fund should benefit the University in perpetuity. If the need for this fund should cease to exist or so diminish as to provide unused income, then another use shall be designated by the Foundation Board in consultation with the dean of the Fisher College of Business in order to carry out the desire of the donors.

\$52,615.00

The Pauline and Jean Wyer Scholarship Fund

The Pauline and Jean Wyer Scholarship Fund was established on November 1, 2002, in accordance with the guidelines approved by the Board of Directors of The Ohio State University Foundation, with gifts from the Trust of Edwin H. Ziegfeld (B.S.Land.Arch., 1927; B.S.Ed., 1933) of Claremont, California.

All gifts are to be invested by the Foundation, under the rules and regulations adopted by the Foundation's Board of Directors, with the right to invest and reinvest as occasion dictates.

REPORT ON UNIVERSITY DEVELOPMENT (contd)

THE OHIO STATE UNIVERSITY FOUNDATION (contd)

Establishment of Named Endowed Funds (contd)

The Pauline and Jean Wyer Scholarship Fund (contd)

The annual income shall be used to provide financial aid scholarships. The scholarships shall be awarded in consultation with the University Committee on Student Financial Aid.

It is the desire of the donor that this fund should benefit the University in perpetuity. If the need for this fund should cease to exist or so diminish as to provide unused income, then another use shall be designated by the Foundation Board in consultation with the director of Financial Aid in order to carry out the desire of the donor.

\$51,181.40

The Stephen D. Milligan Family Scholarship Fund

The Stephen D. Milligan Family Scholarship Fund was established on November 1, 2002, in accordance with the guidelines approved by the Board of Directors of The Ohio State University Foundation, with gifts from Stephen D. Milligan (B.S.Bus.Adm., 1985).

All gifts are to be invested by the Foundation, under the rules and regulations adopted by the Foundation's Board of Directors, with the right to invest and reinvest as occasion dictates.

The annual income shall be used to provide scholarship costs of student athletes who are pursuing undergraduate degrees at The Ohio State University and participating on the varsity football team. Recipients shall be selected by the director of Athletics in consultation with the University Committee on Student Financial Aid.

It is the desire of the donor that this fund should benefit the University in perpetuity. If the need for this fund should cease to exist or so diminish as to provide unused income, then another use shall be designated by the Foundation Board as recommended by the director of Athletics in order to carry out the desire of the donor.

\$46,706.00

The Lloyd L. and Ilma L. Dowell Family Medicine Fund

The Lloyd L. and Ilma L. Dowell Family Medicine Fund was established on November 1, 2002, in accordance with the guidelines approved by the Board of Directors of The Ohio State University Foundation, with a gift from Ilma L. Dowell (B.S.Ed., 1933) and made in memory of Lloyd L. Dowell (B.A., 1932; M.D., 1935) of North Canton, Ohio.

All gifts are to be invested by the Foundation, under the rules and regulations adopted by the Foundation's Board of Directors, with the right to invest and reinvest as occasion dictates.

The annual income shall be used to support the clinical research, teaching, and patient care activities of the Department of Family Medicine, particularly those related to heart disease and Alzheimer's disease. Distribution shall be made upon the recommendation of the chairperson of the Department Family Medicine in the College of Medicine and Public Health in consultation with senior vice president for Health Sciences and dean of the College of Medicine and Public Health.

REPORT ON UNIVERSITY DEVELOPMENT (contd)

THE OHIO STATE UNIVERSITY FOUNDATION (contd)

Establishment of Named Endowed Funds (contd)

The Lloyd L. and Ilma L. Dowell Family Medicine Fund (contd)

It is the desire of the donor that this fund should benefit the University in perpetuity. If the need for this fund should cease to exist or so diminish as to provide unused income, then another use shall be designated by the Foundation Board in consultation with the senior vice president for Health Sciences and dean of the College of Medicine and Public Health in order to carry out the desire of the donor.

\$27,990.00

The Phillip Wm. Fisher MBA Fellowship Fund

The Phillip Wm. Fisher MBA Fellowship Fund was established on November 1, 2002, in accordance with the guidelines approved by the Board of Directors of The Ohio State University Foundation, with gifts from Phillip Wm. Fisher of Detroit, Michigan.

All gifts are to be invested by the Foundation, under the rules and regulations adopted by the Foundation's Board of Directors, with the right to invest and reinvest as occasion dictates.

The annual income shall be used to support a Master of Business Administration fellowship. Selection shall be made by The Max M. Fisher College of Business with formal approval by the dean of the Fisher College of Business in consultation with the University Committee on Student Financial Aid.

It is the desire of the donor that this fund should benefit the University in perpetuity. If the need for this fund should cease to exist or so diminish as to provide unused income, then another use shall be designated by the Foundation Board in consultation with the dean of the Fisher College of Business in order to carry out the desire of the donor.

\$25,000.00

The Oliver E. Hamilton Family Endowed Scholarship Fund

The Oliver E. Hamilton Family Endowed Scholarship Fund was established on November 1, 2002, in accordance with the guidelines approved by the Board of Directors of The Ohio State University Foundation, with a gift from Oliver E. Hamilton (A.A., 2002).

All gifts are to be invested by the Foundation, under the rules and regulations adopted by the Foundation's Board of Directors, with the right to invest and reinvest as occasion dictates.

The annual income shall be used to provide scholarships for undergraduate and graduate students at The Ohio State University at Marion who are single parents. Preference shall be given to those students who have demonstrated need due to unique life circumstances, and who may need an additional source of financial aid. Scholarships will be awarded in consultation with the University Committee on Student Financial Aid.

It is the desire of the donor that this fund should benefit the University in perpetuity. If the need for this fund should cease to exist or so diminish as to provide unused income, then another use shall be designated by the Foundation Board as recommended by the dean and director of The Ohio State University at Marion, in consultation with the Ohio State Marion Scholarship Committee in order to carry out the desire of the donor.

\$25,000.00

WAIVERS OF COMPETITIVE BIDDING REQUIREMENTS

Resolution No. 2003-56

JULY - SEPTEMBER 2002

Synopsis: Acceptance of the quarterly report on waivers of competitive bidding requirements is proposed.

WHEREAS the Purchasing Policy of The Ohio State University adopted by the Board of Trustees on September 7, 1984, and revised on February 7, 1992, July 8, 1994, November 7, 1997, and March 1, 2002 provides that the President and/or the Senior Vice President for Business and Finance, or for the Hospitals of the University and their related facilities, the Vice President for Health Services, may grant a waiver from competitive bidding in the event of an emergency, when a sufficient economic reason exists or when the goods or services can be purchased from only a single source, with a report on such waivers to be made quarterly to this Board; and

WHEREAS the Senior Vice President for Business and Finance has submitted a report on waivers of competitive bidding requirements granted for the period of July - September 2002; and

WHEREAS during the period covered, the Senior Vice President for Business and Finance, at the requests of the departments making the purchases and upon the recommendation of the Purchasing Department, granted 62 waivers of competitive bidding requirements for annual purchases totaling approximately \$7,917,700 as shown on the enclosed exhibit; and

WHEREAS during the period covered, the Vice President for Health Services, at the requests of the Hospitals of the University and their related facilities making purchases, granted 39 waivers of competitive bidding requirements for annual purchases totaling approximately \$18,456,000 as shown on the enclosed exhibit:

NOW THEREFORE

BE IT RESOLVED, That the report on waivers of competitive bidding requirements for the period of July - September 2002 is hereby accepted.

(See Appendix XXIV for background information, page 575.)

CONSTRUCTION CONTRACTS - AMENDMENT TO RESOLUTION 2003-47

Resolution No. 2003-57

WOODY HAYES DRIVE BRIDGE AND STEAM LINE EXTENSION

Synopsis: Authorization to amend Resolution 2003-47, approved at the October 4, 2002 Board of Trustees meeting, to enter into construction contracts for the Woody Hayes Drive Bridge and Steam Line Extension project is requested.

WHEREAS the University desires to demolish the existing Woody Hayes Drive bridges over the Olentangy River and Olentangy River Road and replace them with new bridges and install a high-pressure steam line under the bridge structure and connected to the existing lines; and

WHEREAS the total estimated project cost is \$9,869,745 and the total estimated construction cost is \$8,625,156, with funding provided by future University bond proceeds (\$8,400,000), Transportation and Parking (\$16,950), and Department of Physical Facilities (\$1,452,795):

CONSTRUCTION CONTRACTS - AMENDMENT TO RESOLUTION 2003-47 (contd)

NOW THEREFORE

BE IT RESOLVED, That the President and/or Senior Vice President for Business and Finance be authorized to enter into construction contracts for the Woody Hayes Drive Bridge and Steam Line Extension project in accordance with established University and State of Ohio procedures with all actions to be reported to this Board at the appropriate time.

(See Appendix XXV for background information and map, page 577.)

EMPLOYMENT OF ARCHITECTS/ENGINEERS

Resolution No. 2003-58

MANSFIELD CAMPUS – ADMINISTRATION AND CLASSROOM BUILDING

Synopsis: Authorization to employ an architectural/engineering firm for the Mansfield Campus – Administration and Classroom Building project is requested.

WHEREAS The Ohio State University – Mansfield desires to construct a new building that will alleviate present shortages of space, plan for expected growth, and enhance Ohio State's visibility; and

WHEREAS the preliminary project cost estimate is \$6,537,000 with the design costs being funded by the Mansfield Campus:

NOW THEREFORE

BE IT RESOLVED, That the President and/or Senior Vice President for Business and Finance be authorized to select qualified architectural/engineering firms as necessary for the Mansfield Campus – Administration and Classroom Building project and that the fees for these services be negotiated between the firms selected and the University, provided that no authorization to enter into construction contracts for this project is to be submitted to the Board for approval until there is a memorandum of understanding executed by all the offices involved.

(See Appendix XXVI for background information and map, page 581.)

ROADWAY EASEMENT

Resolution No. 2003-59

CITY OF COLUMBUS
STREET CORNER AT THE INTERSECTION OF
WEST 11TH AVENUE AND HIGH STREET

Synopsis: Authorization to grant a perpetual roadway easement to the City of Columbus for construction of roadway improvements related to the widening of High Street in connection with the Gateway project and for the maintenance and operation of the improvements is proposed.

WHEREAS Campus Partners has requested that The Ohio State University grant a perpetual easement to the City of Columbus for the construction of certain roadway improvements, installations, enhancements, facilities and equipment related to the widening of High Street in connection with its Gateway project and for the maintenance and operation of these improvements across approximately 0.0076 acres of University land located at the northwest corner of the intersection of West 11th Avenue and High Street; and

ROADWAY EASEMENT (contd)

WHEREAS the appropriate University offices have determined that the grant of this easement is in the best interest of the University:

NOW THEREFORE

BE IT RESOLVED, That the President and/or Senior Vice President for Business and Finance be authorized, pursuant to Ohio Revised Code Section 3345.18, to grant to the City of Columbus a perpetual roadway easement over approximately 0.0076 acres of University land for the construction of roadway improvements related to the widening of High Street in connection with the Gateway project and for the maintenance of these improvements.

(See Appendix XXVII for background information and map, page 583.)

Upon motion of Mr. McFerson, seconded by Mrs. Davidson, the Board of Trustees adopted the foregoing resolutions by unanimous roll call vote, cast by Messrs. Patterson, Sofia, Slane, McFerson, Borrer, and Judge Duncan, Mses. Longaberger, Hendricks, and Davidson.

Mr. Patterson:

I just want to note that there has been a tremendous amount of effort put in over a long period of time on the Medical Practice Plan. I think this issue has been an issue as long as I've been a Trustee, and I understand it goes much, much further back before that. There will need to be many additional things that the Board addresses on a go-forward basis, and we will take those in the order in which they need to come before us. Zuheir --

Mr. Sofia:

There was a good presentation given in the Fiscal Affairs Committee meeting this morning. We were informed that there are certain issues, including professional liability insurance, tax issues, and other things the Medical Center has been working on and will bring to the Board at the appropriate time.

MEDICAL PRACTICE PLAN

Resolution No. 2003-60

Synopsis: Approval of a Medical Practice Plan for a College Central Practice Group is proposed.

WHEREAS the Senior Vice President for Health Sciences and Dean of the College of Medicine and Public Health and the leadership of the College of Medicine and Public Health have recommended the adoption of a Medical Practice Plan to establish a single College Central Practice Group; and

WHEREAS the creation of a College Central Practice Group is essential to the ability of the University Medical Center to achieve its goals of excellence in teaching, research and patient care locally, regionally and nationally; and

WHEREAS the new College Central Practice Group provides the structure for the existing departmental practice groups to join as one; and

WHEREAS it is recognized that the provisions of the Medical Practice Plan adopted by the Board in 1995 will remain in effect to allow time for the transition to the new College Central Practice Group:

MEDICAL PRACTICE PLAN (contd)

NOW THEREFORE

BE IT RESOLVED, That The Ohio State University College of Medicine and Public Health Medical Practice Plan for the College Central Practice Group is hereby adopted to become effective December 15, 2002; and

BE IT FURTHER RESOLVED, That The Senior Vice President for Health Sciences and Dean of the College of Medicine and Public Health is hereby delegated the authority to review and approve the College Central Practice Group and to take appropriate actions necessary to implement this resolution and the Medical Practice Plan in accordance with established University procedures.

(See Appendix XXVIII for background information, page 585.)

Upon motion of Mr. Borrer, seconded by Mr. Slane, the Board of Trustees adopted the foregoing resolution by unanimous roll call vote, cast by Messrs. Patterson, Sofia, Slane, McFerson, Borrer, and Judge Duncan, Mses. Longaberger, Hendricks, and Davidson.

--0--

Thereupon the Board adjourned to meet Friday, December 6, 2002, at The Ohio State University Fisher College of Business, Columbus, Ohio.

Attest:

Maureen T. Sharkey
Assistant Secretary

James F. Patterson
Chairman

UPDATE

Since the September Board Meeting

Karen A. Holbrook

Meetings With Student Organizations/Groups/Leaders

- Student leaders of SGA, Professional Students Organization and Council of Graduate Students (with Student Affairs)
- Student Diversity Group Leaders (50) (with Student Affairs)
- Eddie Pauline

Student Events

- Homecoming Parade

Meetings With Faculty and Staff Organizations; Boards

- OSU Foundation Board
- Staff Advisory Council Executive Committee
- University Council on Diversity
- Alumni Advocates meeting
- University Senate
- Strategic Planning Group – School of Medicine and Public Health
- Hosted New Faculty reception
- Attended Provost Dean and Administrators reception/dinner
- Visited Council of Deans Meeting
- Faculty Leadership Group (Susan Fisher, Gene Mumy and Stan Ahalt)
- Secretary of the University Senate
- Presidents and Provost's Faculty Advisory Council
- University Hospital Board
- Executive Committee of GLBT Organization
- Wexner Center Board
- University Development Staff dinner
- Student Affairs Diversity Council
- Alumni Advisory Council - opening presentation and exit interview

Meetings with Deans and Other OSU Administrators and Program Leaders

- Dr. Elizabeth Lenz – Dean of Nursing
- Dr. Joseph Alutto – Dean of Business
- Dr. Jan Kronmiller, Dean of Dentistry
- Professor Nancy Rodgers, Dean of Law
- Dr. Karen Bell, Dean of Fine Arts
- Dr. Mike Hogan, Dean of Humanities

- Dr. Glenn Hoffsis, Dean of Veterinary Medicine
- Sherri Geldin, Director of the Wexner Center
- Dr. Susan Hartmann and Mark Ellis; Faculty Athletic Representative and Chair, Faculty Athletic Committee
- Regular meetings with senior team - Ed Ray, Bill Shkurti, Fred Sanfilippo, Ginny Trethewey, Jerry May, Andy Geiger, Brad Moore, Bill Hall *et al.*,
- Regularly scheduled cabinet - 2-3 hrs discussion each Wednesday of agenda items and open conversation

Meetings With Community Organizations and Groups

- Presented the keynote talk at the Women's Hall of Fame luncheon: "Women Leading the Way in the 21st Century: Why so Slow, and Whose Responsibility is it?"
- Introductory luncheon meetings
 - Tom Hoaglin, George Skestos and Zuheir Sophia
 - Jerry Jurgenson and the executive team of Nationwide
 - Michael Fiorile and Sally Jackson - Columbus Chamber of Commerce
 - Alex Shumate
- Dr. Robert Massie and Dr. Bruce Bursten - Chemical Abstracts relationship to Ohio State
- Columbus Technology Leadership Council - pre-board briefing
- SciTech Director, Ora Smith - pre-board briefing
- Columbus Chamber of Commerce Meeting
- Columbus Technology leadership Council Meeting
- SciTech Board at OSC - tour Computer Arts Animation Laboratory
- Consultants for the Columbus Downtown Development Council

Meetings With Alumni and Friends of the University Away from Campus

- Vince and Pat Aveni, at their home
- Patterson Farms - Jim and Nancy Patterson

Meetings With Editorial Boards and Members of the Press

- Plain Dealer - Cleveland
- Chicago Tribune
- Columbus Dispatch Editorial Board
- Columbus Call and Post Publisher
- Channel 10 interview
- Channel 6 interview
- Skip Mosaic - half-time interviews for all games

Welcome Receptions

- Jennings Reception for minority community leaders
- Annual Women's Reception
- Ambassador Milton Wolf's home in Cleveland
- Welcome reception from the student leaders
- Reception hosted by YWCA, Columbus Chapter of Links, The Women's Fund of Central Ohio, and Junior League - approximately 400 women
- Office of Minority affairs reception

Classroom Activities

- Taught a class in Educational Policy and Leadership

Special University Events

- Endowed Scholars Event – recognizing those students who have received such awards and honoring the 25 years of support from the Battelle Honors Program
- Diversity lecture series
 - Introduced Nancy Hopkins, MIT
 - Introduced Morris Dees, Center for Southern Poverty and the Law
- Mathematical Biosciences Gala – first national workshop on neural networks; Rita Colwell, Director of NSF as special guest
- Football Captains Breakfast
- Family Weekend Brunch – Remarks to parents and students
- Ohio State Alumni Awards Banquet
- University Distinguished Lecture
- Glenn Gubernatorial Debate

National Meetings Held on the OSU Campus or OSU Sponsored Held Off Campus

- Seiko A. Heiskanen Symposium on Geodesy – College of Engineering
- Outreach and Engagement Conference – “Catalyst for Change” - co-sponsored with Penn State and the University of Wisconsin Extension; opening remarks and introduction of Dr. Judith Ramaley, keynote speaker, National Science Foundation; formerly president of Portland State University and University of Vermont)

Campus-Wide Communications

- welcome letter to students and faculty
- reminder of tolerance in today's uncertain times

Off Campus Events

- IUC President's Meeting
- Embry Riddle Aeronautical University Board of Trustees Meeting – Prescott, Arizona
- AAU President's Meeting – Emory University
- Society of Research Administrators International meeting – Keynote Speaker “The High Cost of Success in Research;” received the Distinguished Contribution to Research Award from SRA

Off Campus Visitors

- Rita Colwell, Director National Science Foundation
- Senators Voinovich and DeWine visits to campus – discussion and lunch

Searches Underway

- Vice President for Governmental Affairs – Bob Moser, chair
- Vice President for External Affairs – Bill Shkurti, chair

Development and Social Events

- Columbus Museum of Arts Annual Ball
- Veterinary Medicine Alumni tailgate
- Donor dinner and Paul McCartney concert

External Invitations

- to serve as a member of the Board of ACE
- to serve as the keynote speaker at the Southern University Council of Presidents – on the topic of “Access and Excellence”
- to present the commencement address at the University of Toledo
- to speak at Columbus Rotary, November 25

Repeating Issues

- Diversity as an Issue
- Undergraduate Education – Faculty/student engagement
- Technology Transfer and Economic Development
- Access and Cost of Education
- University and Community Citizenship

**Waivers of Competitive Bidding Requirements
July-September 2002**

(APPENDIX XXIV)

<u>Category</u>	<u>Total</u>	<u>Sole Source</u>	<u>Emergency</u>	<u>Sufficient Economic Reason</u>
Hospitals Merchandise for Resale	\$600,000	\$600,000	\$0	\$0
Hospitals - Professional Health Care Services	\$8,030,057	\$811,834	\$934,000	\$6,284,223
Hospitals - Equipment and Services	\$9,825,968	\$8,416,450	\$192,048	\$1,217,470
Merchandise For Resale	\$975,000	\$975,000	\$0	\$0
Instructional and Research Equipment and Services	\$1,228,764	\$447,913	\$59,758	\$721,093
Administrative Support Equipment and Services	\$5,530,021	\$3,589,737	\$304,606	\$1,635,678
Conference Facilities	\$183,888	\$75,000	\$52,269	\$56,619
TOTAL	\$26,373,698	\$14,915,934	\$1,542,681	\$9,915,083



Woody Hayes Drive Bridge and Steam Line Extension

5062-PF990609

Requesting Agency(s): PHYSICAL FACILITIES

Location(s): Unidentified Bridge-Col. Gross Sq. Ft.: 0 Age:

Description: The Woody Hayes bridges that span the Olentangy River and Olentangy River Road were constructed in 1921. A detailed engineering inspection in February 1995 indicated a need for extensive structural rehabilitation. This project would demolish the existing bridges over the Olentangy River & Olentangy River Road and replace them with new bridges that have four 12' lanes with 10' sidewalks on each side, as well as provide ADA accessibility to the bridges from the parking areas. The bridges would be built using part-width construction allowing maintenance of traffic on the bridges. A vertical clearance of 15'6" is required to meet the current AASHTO standard.

Included with this project is the construction of a high-pressure 10" steam line, which would be installed on the bridge under-structure and connected to the existing line near St. John Arena & Ag Eng. The recommended single structure would allow for the opening of the river corridor as well as accommodating a bike path along the east bank of the Olentangy River without encroaching on the waterway.

Project Team:

Facility Planner: Is Unassigned

Project Captain: Paul Sherwood
(Sherwood.1@osu.edu)

Project Assistant: Karen Cogley
(cogley.1@osu.edu)

Field Coordinator: Mark Hartmann
(hartmann.16@osu.edu)

Source of Funds:

	Original	Revised
General Funds-Business & Admin	\$0.00	\$0.00
Future Univ. Bond Issues	\$6,500,000.00	\$8,400,000.00
Auxiliaries-Trans. & Parking	\$0.00	\$16,950.00
Repair & Renovation Fiscal Yr 02-03	\$71,513.69	\$1,452,795.00
Total:	\$6,571,513.69	\$9,869,745.00

Project Information:

Project originally approved by the Board of Trustees on July 2, 1999 at a value of \$6.5 million. The project budget was increased to \$8.4 million to incorporate the steam line extension work (project #5062-PF990627). Project increased to \$9.8 million following receipt of bids to reflect the acceptance of alternates and additional contingency.

Uses of Funds:

	Original	Revised
Construction	\$5,850,000.00	\$8,625,156.31
Contingency	\$44,225.69	\$431,258.13
Design	\$650,000.00	\$782,280.00
University Administration	\$27,288.00	\$31,050.56
Total:	\$6,571,513.69	\$9,869,745.00



Woody Hayes Drive Bridge and Steam Line Extension

5062-PF990609

Schedule:	Projected	Revised	Actual
Planning			
Arch/Engr Approved by B/T	07/02/1999		07/02/1999
Bidding Approved B/T	07/02/1999	10/14/2002	
Design			
Construction Document Approval	04/04/2002		06/13/2002
Bidding			
Bid Opening	09/20/2002	09/20/2002	09/20/2002
Bid Opening	08/07/2002		08/16/2002
Construction			
Construction Start	07/01/2000	10/09/2002	
Completion	07/01/2002	04/08/2005	

Woody Hayes Drive Bridge and Steam Line Extension

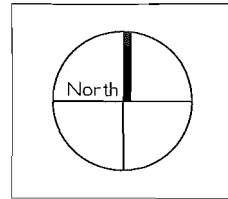
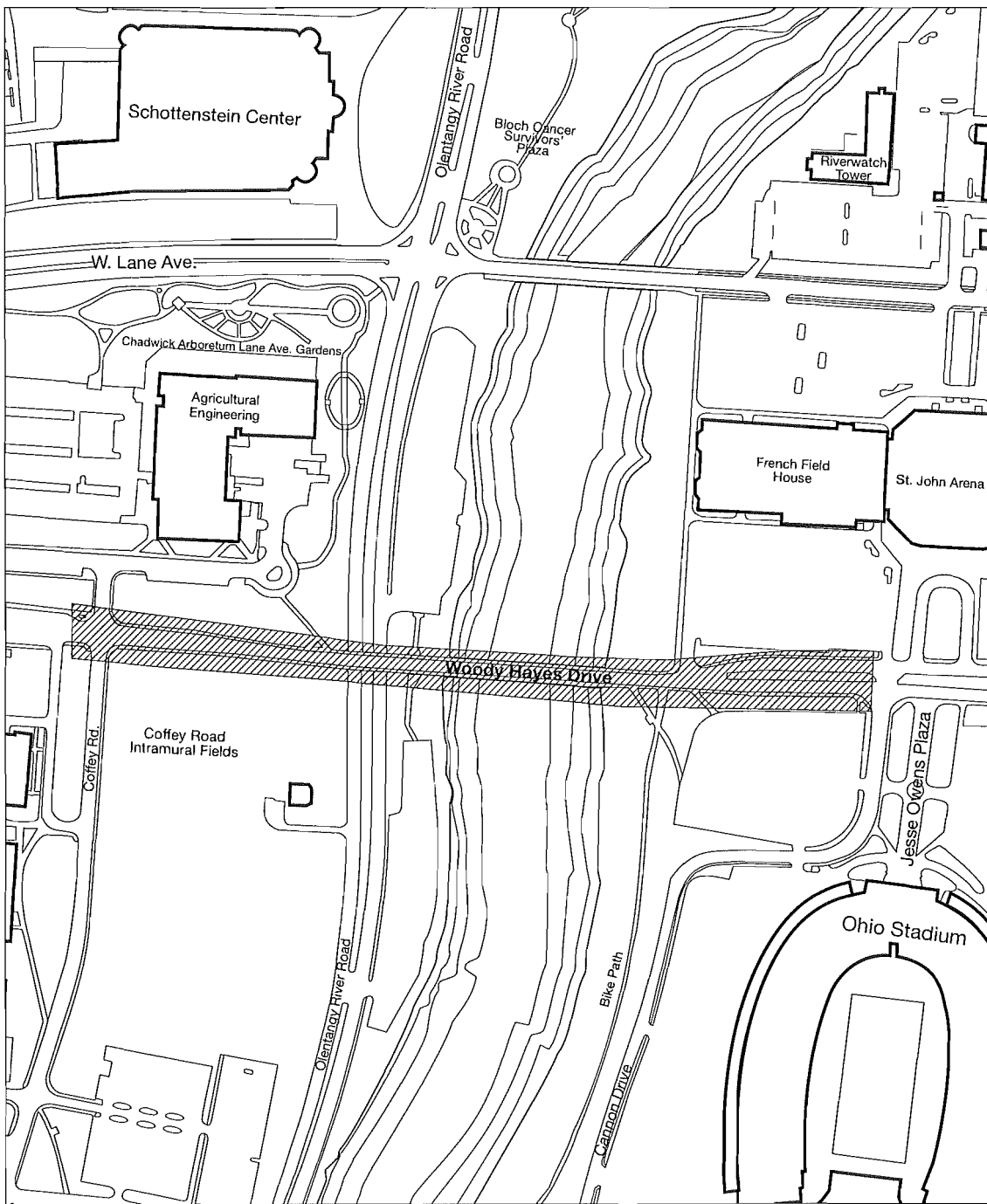

Office of Business and Finance
Office of Facilities Planning and Development

December 9, 2000

Mansfield Campus - Administration and Classroom Building

315-2002-929



Requesting Agency(s): MANSFIELD CAMPUS

Location(s): Site - See Comments. Gross Sq. Ft.: 0 Age:

Description: Construct an approximately 30,000 gross square foot building to house all Student Services offices, Business Office, Dean/Directors Suite, University Reception and Switchboard area, Campus Security, Center of Corporate & Community Education, Education Department (classroom, labs and offices), and Music Department (classroom, labs and offices). Sited to create a focal building, increase visibility of Ohio State University Mansfield and improve accessibility to the functions and services provided within.

Project Team:

Facility Planner: Anne Pensyl (pensyl.3@osu.edu)
Project Captain: Marty Bricker
Project Assistant: Leeanne Chandler (chandler.63@osu.edu)
Field Coordinator: Is Unassigned

Project Information:

Preliminary budget is \$6,537,000.00

Local Administration to be requested.

The site is located to the northwest of the existing service center, directly west of the child development center, between the entry drive and the main parking lot.

Schedule:

Planning

Arch/Engr Approved by B/T

Projected

11/01/2002

Revised

Actual

Mansfield Campus - Administration and Classroom Building

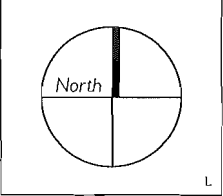
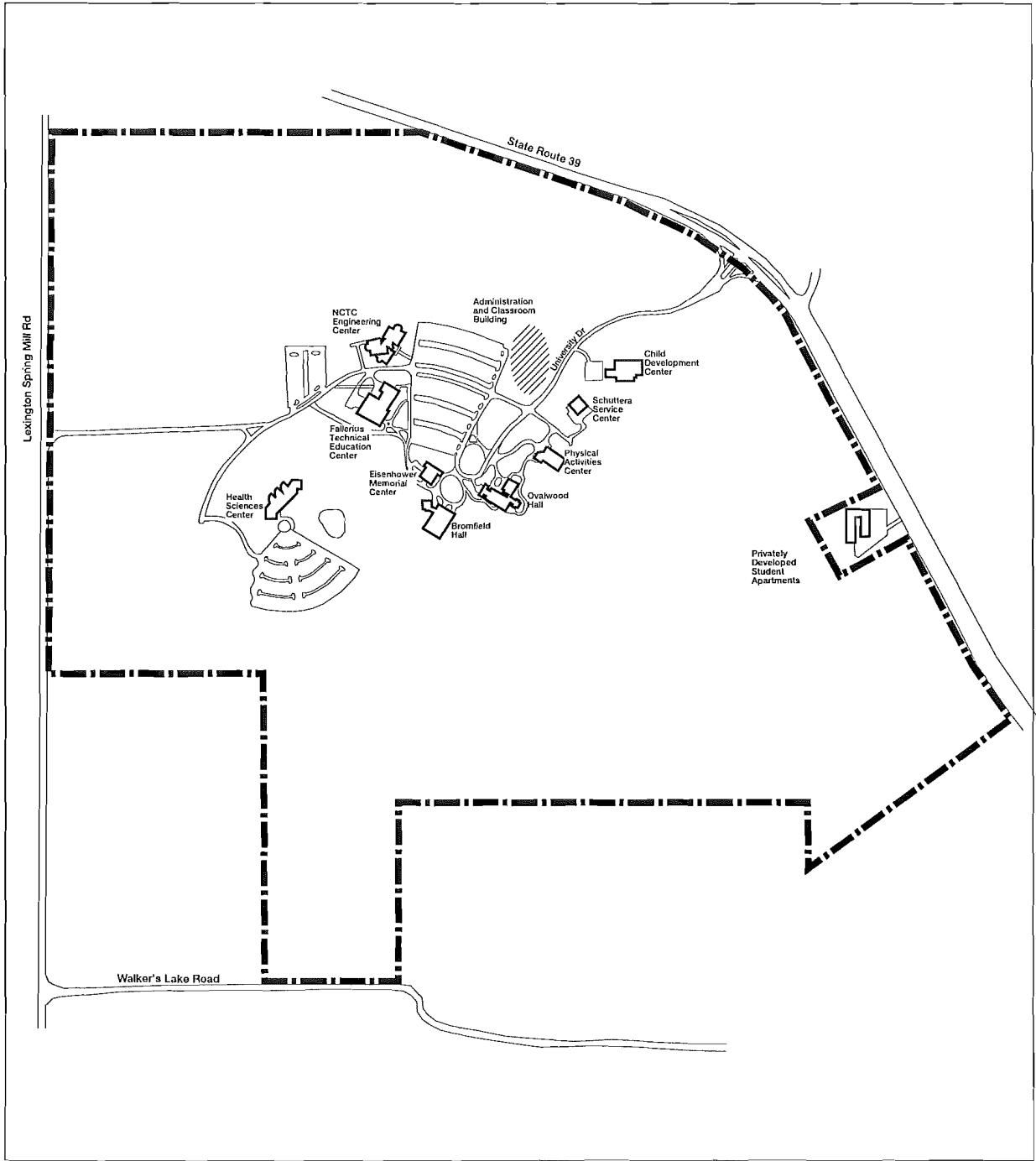

Office of Business and Finance
Office of Facilities Planning and Development

October 29, 2002

(APPENDIX XXVII)

ROADWAY EASEMENT

CITY OF COLUMBUS
STREET CORNER AT THE INTERSECTION OF
WEST 11TH AVENUE AND HIGH STREET

Campus Partners is requesting that the University grant a perpetual roadway easement to the City of Columbus across approximately 0.0076 acres of University property located at the northwest corner of the intersection of West 11th Avenue and High Street for construction of roadway improvements related to the widening of High Street in connection with the Gateway project. This perpetual easement will be granted pursuant to Ohio Revised Code Section 3345.18, which provides that the University, on behalf of the State, may grant perpetual roadway easements to municipal corporations.

Roadway Easement - 0.0076 Acres City of Columbus

Street Corner at the Intersection of West 11th Avenue and High Street

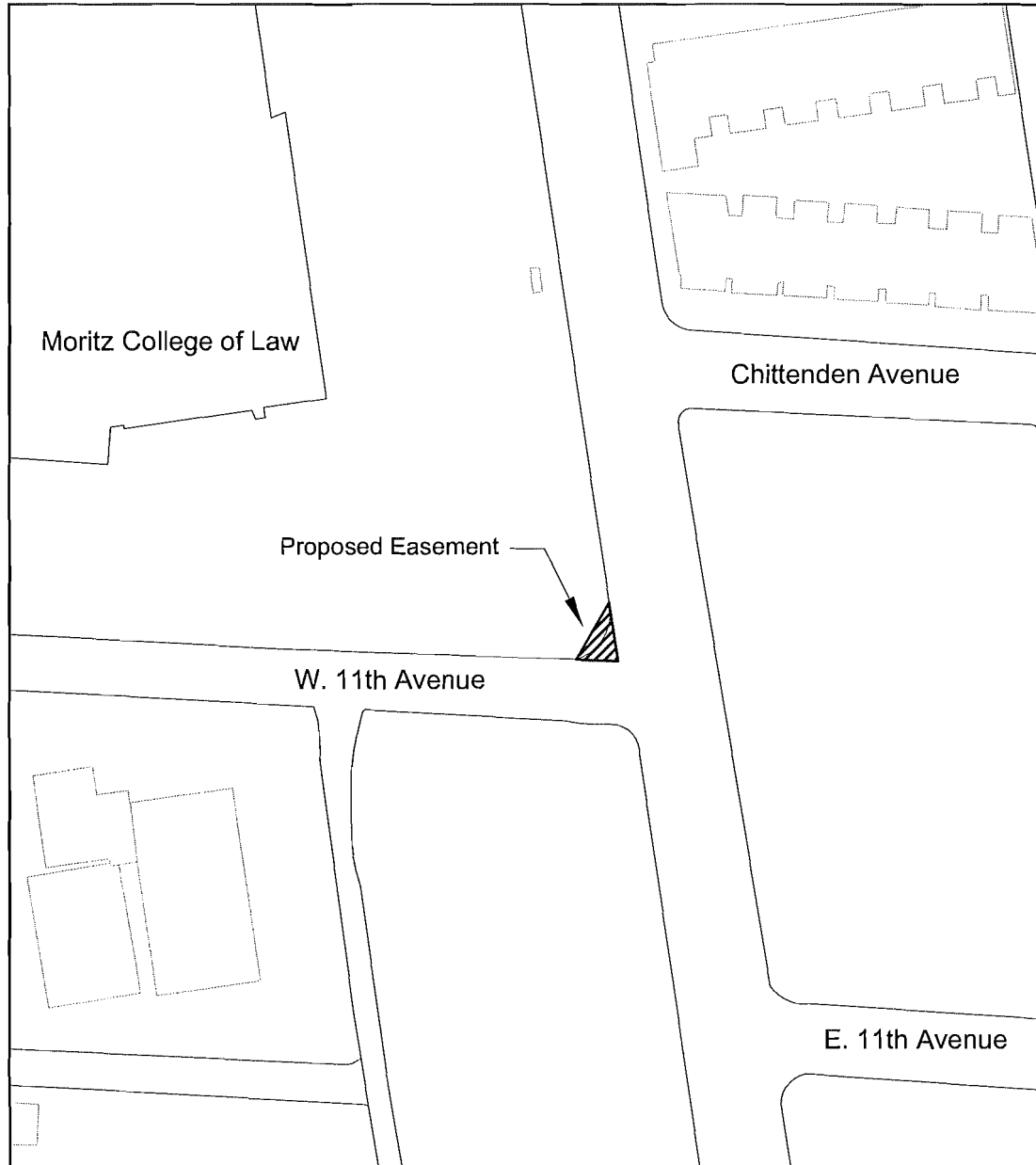

No True Scale

Office of Business and Finance
November 1, 2002



 Site of Roadway Easement

Map Provided by University Engineer's Office

(APPENDIX XXVIII)

**BACKGROUND FOR MEDICAL PRACTICE PLAN
FOR A COLLEGE CENTRAL PRACTICE GROUP
FOR THE COLLEGE OF MEDICINE AND PUBLIC HEALTH**

In 1985, the Board of Trustees of the Ohio State University approved a Medical Practice Plan establishing departmental practice groups for the clinical departments of the College of Medicine and Public Health. The plan was most recently amended in 1995.

The attached resolution establishes a college central practice group to include the faculty of all the clinical departments. This new Medical Practice Plan will coexist with the previously recognized practice plan to allow the departmental groups sufficient time to properly plan for the transition into the new college central practice group.

The Ohio State University Board of Trustees

November 1, 2002

THE OHIO STATE UNIVERSITY
COLLEGE OF MEDICINE AND PUBLIC HEALTH MEDICAL PRACTICE PLAN FOR THE COLLEGE
CENTRAL PRACTICE GROUP

Preamble:

The primary goals of The Ohio State University College of Medicine and Public Health (COM&PH) are to provide education, research and service in medical disciplines. To advance these goals, it is necessary to provide patient care, a consequence of which is the generation of practice income. This authorization for a College Central Practice Group ("the CCPG") is predicated on two principles. First, the provision of patient care services by the regular and auxiliary faculty through the CCPG is an essential and critical part of their employment at OSU. Second, a significant proportion of such income is used for academic enrichment and to enhance our faculty goals. This practice plan contains the policies, rules and procedures for the management and use of practice income through the CCPG.

I. Introduction and Scope of Coverage

These policies (hereinafter referred to as "the Practice Plan") shall be incorporated in and be a part of the annual contract of employment between The Ohio State University and all regular and auxiliary faculty members appointed in a clinical department of the COM&PH. This Practice Plan has been adopted by the Board of Trustees of The Ohio State University to become effective December 15, 2002, and can be amended only by formal action of the Trustees.

II. Definitions

For purposes of this Practice Plan:

- (A) "Regular faculty member" shall mean a person holding a faculty appointment on the regular track or regular clinical track requiring fifty percent or more service to the University in a clinical department of COM&PH and who is providing patient care services.
- (B) "Auxiliary faculty member" shall mean a person holding a clinical, adjunct, or other appointment requiring fifty percent or more service to the University in a clinical department in the COM&PH who is not a regular faculty member, and who is providing patient care services.
- (C) "Practice income" shall mean all collections (less refunds) received by a faculty member or the CCPG on his or her behalf from such faculty member's patient care services.
- (D) "OSU" shall mean The Ohio State University.
- (E) "Clinical Departments" shall mean the following academic Departments in the COM&PH: Anesthesiology, Emergency Medicine, Family Medicine, Internal Medicine, Neurology, Obstetrics and Gynecology, Ophthalmology, Orthopedic Surgery, Otolaryngology, Pathology, Pediatrics, Physical Medicine & Rehabilitation, Psychiatry, Radiology, and Surgery.
- (F) "Academic year" shall mean the period beginning July 1 and ending on June 30 of the following calendar year or such other fiscal year as may be adopted by OSU.
- (G) "Dean" shall mean the Dean of the OSU College of Medicine and Public Health.

- (H) "Senior Vice President" shall mean the Senior Vice President for Health Sciences.
- (I) "Health System" shall mean all hospitals and medical facilities owned by the University.

III. Compensation and Support for Regular Faculty

(A) Salary

Faculty members in the COM&PH may receive a salary from the OSU general funds budget.

(B) Practice Income

Subject to the obligations detailed herein, the regular and auxiliary faculty members may establish their professional fees and bill for, collect, and retain all fees for all patient care services rendered by such faculty members.

All regular and auxiliary faculty members of each clinical department of the COM&PH are members of the CCPG and as such will have all financial data managed and disclosed by the CCPG to the Chairperson of that department and to the Dean. The disclosure shall include all practice income, expenses and institutional support related to the departmental faculty, including the Chairperson, associated practice expenses and the total amount of annual support provided to the department and to the COM&PH.

The Dean will disclose the totals for the COM&PH to the Senior Vice President and the President of OSU.

IV. Cost Related to Patient Care Services

(A) Determination of Costs

OSU and the Health System will maintain accurate records of the total costs (direct and indirect) incurred in University medical facilities. It is recognized that a portion of these total costs results from the performance of the teaching and research functions of OSU and that this portion of these costs is an appropriate expense of OSU.

Appropriate representatives of the CCPG will meet no fewer than sixty days prior to the beginning of each academic year, with appropriate representatives of OSU and the Health System to develop a practice budget. That budget is to include the direct and indirect costs incurred in University facilities used by regular and auxiliary faculty members in each Department to provide patient care services from which regular faculty members will be deriving practice income. Such costs are to be reduced by an amount which, in the judgment of OSU, reflects a proper charge for the Department teaching and research functions performed in the OSU facilities and are to be no more than the costs for which similar facilities could be obtained from a competitive source in which there is no teaching or research function for which payment must be made. No charge is to be made for University medical facilities for which OSU or the Health System makes a separate charge to the patient.

Appropriate OSU and Health System costs records will be made available to the CCPG. Upon request, the CCPG will meet with representatives of Health System to discuss such cost records, including proposed indirect costs and the amount of the charge for the teaching and research functions.

(B) Payment

The charges for practice costs will be stated on an annual basis, one quarter of which will be paid by the CCPG on the last day of September, December, March and June of each academic year for the prior quarter. Payment will be made to the Health System.

V. Academic Enrichment Programs

(A) Teaching and Research Fund of the College

In order to enhance teaching and research and provide for related capital needs there shall be within the COM&PH a Teaching and Research Fund (TRF) to be administered by the Dean. The TRF will be perpetuated through annual payments based on total of practice income generated by each Department's regular and auxiliary faculty. The annual payments will be 3% of practice income. This percentage may be adjusted by the Senior Vice President and Dean with the agreement of the CCPG. The Dean will annually provide to the Council of Chairs, Faculty Council, and the CCPG a budget proposal for the expenditure of these funds and a report on the preceding year's expenditures.

Payments to the TRF will be made to the College by the CCPG on a quarterly basis: the last day of September, December, March, and June of each academic year based upon an estimate of gross practice income with final reconciliation to be made at the end of June of each academic year. The TRF is separate and distinct from the departmental academic enrichment programs.

(B) Departmental Academic Enrichment Programs

In order to enhance the teaching and research activities within each clinical department, each clinical department shall establish an academic enrichment program which is supported by practice income. It is recognized that the Clinical Departments have varying needs for, and varying abilities to support, academic enrichment programs calling for funds in addition to the payment of costs incurred in connection with patient care services. A single plan applicable to all faculty members can result in inequities, both for the faculty and for the COM&PH. Instead, academic enrichment programs should be developed through Departmental faculties under the guidance of the Dean. Such programs should identify those payments which clearly support the teaching, research and academic service missions of the department. The annual payments to departmental enrichment programs shall amount to at least 20% of the gross aggregate practice income for all clinical departments in the COM&PH.

This payment is above and beyond the cost of practicing medicine, which is also borne by each participating department.

The Dean will establish general guidelines for the development of Departmental academic enrichment programs, including but not limited to the following:

- (1) Support of the departmental teaching mission including, but not limited to, scholarships, tuitions, recruitment, continuing medical education, salaries and stipends for students, residents, fellows and other trainees, faculty and staff.
- (2) Support of the departmental research mission including personnel, space, equipment and supplies.

Upon an affirmative vote of at least 75% of the voting regular faculty holding appointments in the Department, the Academic Enrichment Program will become effective and mandatory on all regular and auxiliary faculty members. A Departmental

academic enrichment program may be amended from time to time or rescinded by an affirmative vote of at least 75% of the voting regular faculty members holding appointments in the Department.

Upon approval by the Chairperson, the Departmental Academic Enrichment Program shall be submitted to the Dean annually for the Dean's approval. The Department Chairperson or the Dean may from time to time recommend changes in any Departmental academic enrichment program. Their recommendations will be considered by the regular faculty members in the Department. The results of such consideration will be sent to the Department Chairperson, and the Dean for the Dean's approval.

Each Department Chairperson will file an annual program report with the Dean. This report will outline the academic enrichment program adopted by the regular faculty members and the academic enrichment achieved by such program during the prior year.

Payments to the COM&PH will be made by the CCPG on a quarterly basis: the last day of September, December, March and June of each academic year based upon an estimate of gross practice income with final reconciliation to be made at the end of June of each academic year.

VI. Recognition of the CCPG.

The CCPG shall be incorporated under the laws of the State of Ohio as a not-for-profit corporation. There may be only one CCPG and it must represent all regular and auxiliary faculty members employed by the clinical departments of the COM&PH. A corporation seeking to be recognized as the CCPG shall make application to the Senior Vice President and shall provide to the Senior Vice President copies of its Articles of Incorporation and Bylaws and such other documentation as will establish that it meets the requirements of this practice plan. If the Senior Vice President is satisfied that the corporation meets the requirements of this practice plan, the Senior Vice President shall so notify the applicant organization in writing of the approval and any conditions the organization must meet to maintain this approval. If the Senior Vice President determines that the applicant corporation should not be approved, the Senior Vice President shall provide the applicant corporation with a written explanation of the reasons for not approving the organization as the CCPG.

The Senior Vice President's decision to approve or reject a corporation is committed to the discretion of the Senior Vice President. The Senior Vice President may exercise this discretion by not recognizing the applicant corporation, notwithstanding the fact that it meets the requirements of this Practice Plan. The decision of the Senior Vice President shall be final.

Once a corporation has been recognized as the CCPG, any amendments to the corporation's governance documents must be approved by the Senior Vice President.

Within ninety (90) days of the Senior Vice President's approval, the CCPG and the COM&PH and the Health System shall negotiate an affiliation agreement which shall further describe the relationship between the CCPG, the COM&PH, the Health System and OSU. The agreement shall include, but not be limited to, the following provisions: Support for the academic mission, participation in teaching and research programs, clinical activities at OSU facilities, implementation of this practice plan, financial relationship between the CCPG and OSU and negotiations with third party payors.

The Senior Vice President and Dean shall be entitled to review the CCPG's decision making process and governance documents in order to ensure academic and clinical quality and productivity in each Department of the COM&PH.

In order to maintain individuality and autonomy among departments, each department should continue to have the opportunity to develop its own plan of practice.

VII. Membership in the CCPG.

As a condition of faculty employment, all regular and auxiliary faculty members as defined in Article I will be required to join and remain members of the CCPG. The chair of any clinical department may invite other faculty members to join the CCPG on the same terms as outlined herein.

The CCPG shall administer the patient care practice of all its members, including collection of fees, payment of all members' patient care costs and expenses, departmental academic enrichment and TRF payments as well as distribute all practice income. The CCPG shall provide for major input by the Dean, the chairperson of each department represented in the CCPG, full participation by the faculty, and be subject to complete and full audit, at least annually. The CCPG will submit annually to the Senior Vice President and the Dean a full audit report for the previous year no later than 120 days following the completion of the fiscal year. This report shall be prepared by a public accounting firm and shall provide the aggregate financial data for the CCPG, including practice costs and expenses, TRF payments and all academic enrichment payments paid to any entity for the purposes defined earlier in this document.

THE OHIO STATE UNIVERSITY
OFFICIAL PROCEEDINGS OF THE
ONE THOUSAND THREE HUNDRED AND EIGHTY-NINTH MEETING
OF THE BOARD OF TRUSTEES

Columbus, Ohio, December 6, 2002

The Board of Trustees met at its regular monthly meeting on Friday, December 6, 2002, at The Ohio State University Fisher College of Business, Columbus, Ohio, pursuant to adjournment.

**

**

**

Minutes of the last meeting were approved.

**

**

**

December 6, 2002 meeting, Board of Trustees

The Chairman, Mr. Patterson, called the meeting of the Board of Trustees to order on December 6, 2002, at 10:30 a.m. He requested the Assistant Secretary to call the roll.

Present: James F. Patterson, Chairman, Zuheir Sofia, Daniel M. Slane, Robert M. Duncan, Karen L. Hendricks, Dimon R. McFerson, Jo Ann Davidson, Douglas G. Borrer, Joseph A. Shultz, and Paula A. Habib. Fred L. Dailey, Director of the Ohio Department of Agriculture, was also in attendance.

--0--

Mr. Patterson:

We have an item to bring to the Board at the outset of the meeting, and that is the election of the Secretary of the Board of Trustees. The Personnel Committee, consisting of myself, Zuheir Sofia, and Tami Longaberger, recommends the appointment of the Board Secretary:

ELECTION OF SECRETARY

Resolution No. 2003-61

Synopsis: Election of David O. Frantz as Secretary of the Board of Trustees is proposed.

WHEREAS paragraph (B) of rule 3335-1-02 of the Administrative Code, provides for replacement of Board officers through election; and

WHEREAS there currently exists a vacancy in the position of duly elected Secretary of the Board of Trustees; and

WHEREAS in recognition of the scope of University responsibilities appropriately to be performed by the Secretary, and the necessity for all operational and administrative functions of the Office of the Board of Trustees to be performed under the direction of an Associate Secretary:

NOW THEREFORE

BE IT RESOLVED, That pursuant to paragraph (B) of rule 3335-1-02 of the Administrative Code, David O. Frantz is hereby designated as Secretary of the Board of Trustees of The Ohio State University for a term commencing December 6, 2002, and continuing through the May 2003 meeting of the Board and is empowered to act on behalf of this Board; and

BE IT FURTHER RESOLVED, That Maureen T. Sharkey is hereby designated as Associate Secretary of the Board of Trustees of The Ohio State University effective December 6, 2002, and is empowered to act on behalf of this Board as directed by the Secretary, and in the absence of the Secretary, or if a vacancy in the Board Secretary position occurs, to perform the duties of the Secretary (paragraph (G) of rule 3335-01-02 of the Administrative Code); and

BE IT FURTHER RESOLVED, That all actions duly taken by Maureen T. Sharkey as Assistant Secretary of the Board prior to the effective date hereof are hereby ratified and approved as the official actions of the Secretary of the Board of Trustees; and

BE IT FURTHER RESOLVED, That the Secretary of the Board of Trustees is hereby authorized and directed to incorporate these changes in the applicable sections of the *Bylaws of the Board of Trustees*.

Upon motion of Mr. Sofia, seconded by Ms. Hendricks, the Board of Trustees adopted the foregoing resolution by unanimous roll call vote, cast by Messrs. Patterson, Sofia, Slane, McFerson, Borrer, and Judge Duncan, Mses. Hendricks and Davidson.

Mr. Patterson:

I would like to ask David to please stand and be recognized.

Dr. David O. Frantz:

Mr. Chairman, I would like to thank you for the honor and opportunity to act as Secretary of the Board.

Mr. Patterson:

Thank you. We are just delighted as a Board that we are able to recommend David to be Secretary of the Board. The position is extremely important. David will be performing the secretary's duties and responsibilities, and acting as liaison between the Board and the president, and other parts of the administration and University, and the greater community as well.

Our thought was that David, as a faculty member with vast experience at the University, would be extremely beneficial to this Board in performing our roles and responsibilities. We tremendously look forward to having that opportunity to work with David. And David starts immediately.

I also want to recognize that, as part of the resolution, and I think I was remiss in doing this, the naming of Maureen Sharkey as associate secretary. I also want to recognize Lucy Gandert and Suzanne Blake and the tremendous job that they do in the Board office as well. I know all of you recognize that, but I did want to note it.

--0--

PRESIDENT'S REPORT

President Karen A. Holbrook:

I have passed out to members of the Board of Trustees what I call, "Update November," and it's my report of the activities that have gone on on campus from my perspective and things I've been primarily involved in over the past month. I'm going to tell you the categories and then cite a few of these in particular.

I will continue to put out this report each month that talks about the activities on campus and, in this case, it's about five pages of things that have gone on this time in different categories: Ohio State activities off-campus; community activities; meetings with elected officials; the press; national meetings; status of University-wide searches; some of the external organizations I participate in; and major issues that are under continued discussion on campus. Each time this seems to get to be a little bit more of a lengthy report, but many exciting things, as you all know, go on on this campus.

I'm going to highlight about six of the things that I've talked about in the report. I want to start, of course, by congratulating the wonderful Ohio State football team for a 13-0 victory and taking us to the national championship. This is, of course, something that's really outstanding for our University and we can really thank the student athletes and the coaches for a spectacular season. I start with that because that certainly is the highlight, but I do feel it's necessary to give you a bit of an update on the events that took place the evening following that spectacular victory and where we are today.

Those of you who attended the Academic Affairs Committee meeting this morning had an opportunity to hear Mr. Hall talk a little bit more about what the preparations were prior to that evening and what the activities have been since

PRESIDENT'S REPORT (contd)

President Holbrook: (contd)

then, or what some of the things are that have been done. I'm going to just cite a few of those again, but not in the detail that you've already heard.

I think you all know that immediately after the event Mayor Coleman and I met, along with our own administrative teams prior to that, to craft what our response would be to the community. We went public that day with our response. The next day I had the opportunity to speak to the Rotary Club -- which was some 400-500 members of the community -- and my plan was to talk about the role of higher education and economic development. My sense was that would have been an irresponsible thing to do considering the seriousness of the events the day before, so I changed at the last moment and talked to the community about the events of the night before and what the University was doing.

I now want to say a little bit about the University's response, and as Mr. Hall has said the response has been to engage the entire University community on behalf of the University. There are other activities taking place that I'll mention as well, but the students, the faculty, the staff, and everyone who is related to the University community needs to get involved.

I was very gratified to hear the comments of the students this morning. Briggs Cormier talked on behalf of the graduate students. As many of you may know, a very strong resolution was passed by the Council on Student Affairs and it commits to updating the *Code of Student Conduct* immediately after the first of the year.

Eddie Pauline said some very strong remarks about a grand campaign that I thought was very appropriate. He mentioned this as a student priority issue and I like the fact that he was bold enough to say the word "solve." I, too, agree with him that this is an issue that needs to be resolved, if not solved.

Mr. Hall has talked about the strong sanctions for students and it was mentioned what actions are being taken with our alumni. We have worked as a group to craft near-term and long-term strategies to deal with this issue. We have a continuing communications plan that I'd like to tell you is a positive plan. It is one that is talking about Ohio State -- as we go to the Fiesta Bowl -- being a very exciting and wonderful place to be academically and that is the face we want to put on Ohio State and highlight when we're there. We don't want to dwell on the past, but, instead, really promote all of the good things that are taking place on this campus.

There is going to be a formation of a University-wide task force to look into these issues and to start planning right now for the future -- in many ways to create a change in culture on the campus. We're going to do that ourselves. We're also going to do it in partnership with people in the community and I'll mention a little bit broader strategy momentarily.

This is also a good time to announce, on behalf of Athletics Director Andy Geiger, who has committed funds for us to go forward, that we will put together conferences or whatever it is that we need to do to make this an issue of priority and an issue that we study. Now study doesn't mean we're going to sit back and look at it as an academic venture, but we do have experts on this campus.

For example, we have Dean David Andrews, from the College of Human Ecology, whose area of expertise is specifically related to this kind of behavior. We need to take advantage of those faculty to help us understand a little bit more

PRESIDENT'S REPORT (contd)

President Holbrook: (contd)

about what is going on and how we can make changes. We have other people across the state who have expertise in this area and we will bring them together at a conference with media experts, with mental health experts, and with people around the nation who know how to deal with crisis management situations.

This was actually recommended by our State Senator Jeff Jacobson, who suggested specifically that a summit be pulled together across the State of Ohio, among all of the universities, to talk about fan behavior as a very serious issue. So, out of that, the Inter-University Council -- the presidents started it -- the Student Affairs vice presidents are going to be leading that venture so that we will have a state-wide focus on this as a prelude to a national conference that we hope will take place in the future. The Big Ten is also interested in this and the executive committee of the Big Ten is going to be putting together a plan to also address this situation. This is recognizing that it is not an Ohio State issue alone, but as Vice President Hall has said, this is a social epidemic. It's nationwide and one that we really want to take a leadership role in now to help make some impact on the future.

So I think we have a number of things ongoing, a lot of plans. We look forward to advice from the faculty, from the students, and from anyone who cares to participate to help us. It is a big undertaking and it is one that I think will benefit not only us, but the nation very broadly.

Then it's time for us, now, also, to move on to Ohio State as the great University that it is, and promote that as well. As I said, that is going to be part of our strategy at the Fiesta Bowl. Mr. Hall has also outlined things that will take place at the Fiesta Bowl, again, to show the real quality of the people who are here and that we know represent us as well as possible.

A few other highlights I'll mention, is that during this past month it was International Education Week 2002. The title of that event was, "Securing the Future Through Study and Exchange." This is a very positive way to highlight all of the great things that international students do on this campus. In the Academic Affairs Committee meeting this morning, you heard from the director of the Mershon Center about the marvelous thematic work that is going on, the faculty who are involved, and the various programs that take place to really highlight The Ohio State University's role in a global society in a global economy today. Very exciting.

For those of you who do not know or may not know how important the international population is to The Ohio State University, eight percent, or 4,300, of our students come from countries outside of the United States. Seventy-two percent of those students come from an Asian country. We have five area center studies and we teach 840 courses that have an international component. About 1,300 of our students study abroad each year. We teach nearly 40 languages in 641 different sections and we have over 200 cooperative agreements with other universities abroad. This is indeed a very connected university and one that cares very deeply about the global environment. I think that is very exciting.

I had the good fortune of meeting with a number of international students in both a reception in the College of Humanities where many of those students reside, as well as in a forum that was developed by Dr. Ladman and Dr. Griesberger.

There have been many diversity events that have taken place on campus over the past month. The third President's and Provost's Diversity Lecture was held,

PRESIDENT'S REPORT (contd)

President Holbrook: (contd)

unfortunately at a time when a lot of the campus could not participate. It was a phenomenal lecture by Allen Wolf, from the Boise Center of Religion and Public Affairs at Boston College. He talked about religious diversity and about the United States as being one of the only countries in the world that has always had religious diversity. He traced religion back from the time that the Pilgrims landed on this ground and started, then moved away from the Anglican Church, and then branched out into total religious diversity. It was a very, very provocative and a very exciting lecture.

I also had an opportunity to meet with: the Women's Council on Women's Issues; the Black ministers in the community; and Stonewall Columbus to talk and to meet a number of members of the GLBT population on this campus. This has been a very interesting series of events for me.

We had a number of very special University events, including hosting President Mikhail Gorbachev who was here through the Fisher College. We also awarded an honorary degree to a Nobel laureate, Y. T. Lee from Taiwan; and we awarded the Wexner Prize to William Forsythe of the Frankfort Ballet – another phenomenal event for us.

Also this month was the National Association of Land-Grant Universities and Colleges' meeting and a number of our Ohio State members participated in that organization in very significant and meaningful ways. Just to tell you what kinds of things the presidents of that organization are interested in -- because it tells you it's a summary of what most university campuses are thinking about today -- athletics and national security were at the forefront. Again, Ohio State and its partner Battelle had a role in that through a presentation by Carl Kohrt. Whether public universities are now becoming privatized is an issue as our budgets become downsized at the state level. Working with governing boards was also an important component of that meeting, and we were very privileged to have our own Chairman Jim Patterson as one of the major speakers for that event. His remarks went over extremely well.

As you all know, during this month we had an election and there is new leadership in the Statehouse in many places. This means new challenges and new opportunities for all of us.

I'll conclude my remarks on a high note saying that we are so delighted that Louis Sullivan will be our commencement speaker. Many of you may know Louis Sullivan is the former director of Health and Human Services under the senior George Bush. He is president emeritus of the Morehouse College of Medicine, and now he is chairing President Bush's task force advisory council on HIV and AIDS. He is a marvelous representative of the national health community and I am absolutely delighted that he will be with us as a very senior statesman and our commencement speaker.

Thank you.

--0--

Mr. Patterson:

An item that the Trustees want to address is the events after the Michigan game. The Board of Trustees are extremely interested in the responsibilities that we have as Trustees and the responsibilities of the University to address these problems, recognizing that we accept the responsibility of us as The Ohio State

University family. We also recognize that the issue is happening throughout the country and it's greater than just this University. Our desire, as Karen quoted Eddie Pauline, is finding not only a resolution, but a solution to this problem. In that regard, we would like to present an Expression of Support.

EXPRESSION OF SUPPORT

Resolution No. 2003-62

WHEREAS on November 23, 2002, The Ohio State University's football team and coaches brought great honor and pride to our University and our community by completing a perfect season, posting a 13-0 record and accepting an invitation to compete for the national title in the Fiesta Bowl on January 3, 2003; and

WHEREAS the luster of those outstanding achievements was tarnished by the riotous and destructive activity that occurred in the University area late in the night of November 23; and

WHEREAS the University's response to the unlawful conduct has been swift and firm, including working in concert with Columbus law enforcement and invoking the Student Judicial Code to its fullest extent by immediately suspending all arrested students and aggressively pursuing identification of visible participants who may be subject to arrest; and

WHEREAS faculty members, staff, student government organizations, and the majority of our students abhor the unlawful and violent conduct and have pledged their support for the strongest possible sanctions and are committed to joining in the effort to seek solutions to the underlying causes and problems; and

WHEREAS it is recognized that there are serious societal issues that must be addressed comprehensively and collaboratively if this cycle of random violence is to be curbed:

NOW THEREFORE

BE IT RESOLVED, That the Board of Trustees affirms and supports all actions taken and to be taken by President Karen A. Holbrook and her administration in dealing firmly with all identified perpetrators, and leading a broad based effort of analysis, education, and engagement with the entire community in creating a more positive and constructive university culture.

Upon motion of Mr. Sofia, seconded by Ms. Hendricks, the Board of Trustees adopted the foregoing resolution by unanimous roll call vote, cast by Messrs. Patterson, Sofia, Slane, McFerson, Borrer, and Judge Duncan, Mses. Hendricks and Davidson.

Mr. Patterson:

The issue is important to this University. It will not be solved immediately. It is ongoing and will stretch into the future, but the support of the Board of Trustees for addressing it is strong.

--0--

PRESENTATION ON RESEARCH – DRIVER FOR THE ACADEMIC PLAN

Dr. C. Bradley Moore: [PowerPoint Presentation]

I'm very pleased to have this opportunity to discuss our research program with you again this year. These are exciting times for research at Ohio State. Our new president is a research leader, not only as an accomplished medical researcher but also as an award winning vice president for research.

PRESENTATION ON RESEARCH – DRIVER FOR THE ACADEMIC PLAN (contd)

Dr. Moore: (contd)

The purpose of our University – “To advance the well-being of the people of Ohio and the global community through the creation and dissemination of knowledge” -- is a particularly important one in this era of the knowledge economy. Ohio State’s role has become increasingly central to the success of the State of Ohio.

The overarching goal of our Academic Plan -- The Ohio State University will be among the world’s truly great universities -- is critical for our mission in this global society. We really have to be performing at an international level of excellence and be globally competitive. And, thus, the Office of Research’s mission to bring Ohio State University to a position of international leadership in research and its applications is crucial. Notwithstanding the trials of our limited state budget, we are making good progress on our Academic Plan, and, I believe, this is the best Academic Plan in the United States.

Governor Taft has won reelection on a platform of support for education and for economic development that involves higher education in an integral way. The Governor’s Third Frontier program, \$1.6 billion over 10 years, is a major element of that platform and an extremely important one for us.

Our faculty have been doing their part; they are doing more and better research. Two key measures of research output are publications and the attention that they receive. You will notice in the calendar year 2001, we broke the 3,000 mark on the number of publications for the first time. At least as significant, and in my view much more significant, is the fact that our market share of citations, the number of times people at other places have cited the work of our faculty, is increasing. Here you see that papers published in the years 2000 and 2001 are being cited approximately 20 percent more frequently than papers in previous years. Obviously, papers published in 1997 have been cited a lot more often than ones that were just published last year. This is remarkable progress. We have a ways to go to catch up with our benchmarks still, but we’re moving along quite well.

Research funding is a key input and often an essential one for research. Research grant awards have increased more than the state has managed to cut our budget. Our faculty have been writing lots of proposals, bigger proposals, and more successful ones. This continued double-digit growth in our research budget is an extremely important part of our progress. We have a lot to be proud of in the progress we’ve made in our Academic Plan and we have many important opportunities to look forward to in the future.

Our basic strategy is a leapfrog strategy in research, not a catch-up strategy. Each time we pick a new problem or enter a new field we do it with the idea that we should be the best in the world at what we do, and often we should succeed and sometimes maybe we should be second or third. Our status as a flagship university of a large state and our diversity equip us well to attack the biggest and most complex challenges, intellectual challenges, and societal problems.

The growing collaboration with our neighbor Battelle, the world’s largest private research organization, adds to our strengths in many important ways. I believe that the research opportunities that are opening now are much bigger, more exciting, and more intellectually challenging than ever before. That the impact of universities and, especially, The Ohio State University on the world will grow rapidly.

Let’s take a quick look at some of our progress on specific goals, each a part of building Ohio’s future. First, sustaining and enhancing an outstanding faculty is

PRESENTATION ON RESEARCH – DRIVER FOR THE ACADEMIC PLAN (contd)

Dr. Moore: (contd)

clearly at the center of everything that we do. Faculty members create the great ideas, perform the groundbreaking research, teach the outstanding courses, attract the great students, and perform the outreach and service that brings a strong and positive impact on human society. A great faculty is the sine qua non of a great university.

In sustaining and enhancing our faculty, the first priority under our Academic Plan is to have a competitive salary structure, which with raises target the salaries at the upper end of the Big Ten institutions. Very selective hiring in the most attractive opportunity areas and very successful retention of our best faculty are also key parts of success in this area.

Support services that the Office of Research provides for our faculty and students are the main thing that our office is about -- providing outstanding services at a competitive cost that is benchmarked against the top ten research universities. We have new leadership in most of the areas that our office supports. The service in each unit is benchmarked annually in a quantitative way on how well it meets the needs of our faculty and how those services compare to those at other universities nationally.

A key piece of building our University's reputation is to build the recognition of our research leaders and research programs locally, nationally, and internationally. I feel that our faculty and programs are significantly under-recognized in comparison to their accomplishments. Nonetheless, we have been winning many significant awards and we have many great people doing great work.

You will notice that this is not quite a random sample of awards that our faculty have won, but an entirely different one from those impressive accomplishments which Rick Hermann cited earlier, and one could say many more. Lonny Thompson won the Heineken Prize for Environmental Sciences, and he and his wife Ellen Mosely-Thompson won the 2002 Commonwealth Award for Distinguished Service for Science and Invention. Albert de la Chappelle won the Mauro Bashiroto Award from the European Society for Human Genetics, Umit Oskan received the 2002 Society of Women Engineers award for her work, and Derek Hansen was named one of the world's 100 Top Young Investigators by *Technology Review Magazine*.

Many of you recognize Derek from his picture on the big screen at the 'Shoe in the moonsuit in our new MicroMD Facility. And you might ask, well, did the football team help him win this. Well, I don't know, but this is more exposure than any other scientist in the world gets by being up on that big screen on everybody's TV screen in the United States, and I suspect very much so around the world.

This past year, we began the University Research Lecture Series. Our first lecturer, Norman Borlog, the father of the Green Revolution and winner of the Nobel Peace Prize, spoke Winter Quarter. Sherry Rowland, who won the Nobel Prize in Chemistry for understanding how freons decrease the concentration of ozone in our stratosphere and therefore the likelihood of getting cancer from sunburn, spoke Spring Quarter. President Holbrook already mentioned Professor Lee's lecture. One of the world's leading humanists, Martha Nussbaum, will speak in the Winter Quarter. David McCullough, Pulitzer Prize winning author and biographer, will speak this Spring Quarter. Many of you probably have read his biography of John Adams. And Tom Chek, president of

PRESENTATION ON RESEARCH – DRIVER FOR THE ACADEMIC PLAN (contd)

Dr. Moore: (contd)

the Howard Hughes Medical Institute and Nobel Prize winner for his discovery of self-replicating RNA molecules, will speak this coming Autumn Quarter.

The purpose of this lecture series involving the world's most distinguished research leaders is to highlight the role of research for the University community, for the greater Central Ohio community, and for state government, and, in so doing, to build recognition of Ohio State, its faculty, and its students. That recognition ultimately will have a big impact on our currently stellar status with respect to the numbers of members of the various national academies. We are not passing the competition yet, but we did increase the number of members of those academies this past year. Brit Kirwan was elected to the American Academy of Arts and Sciences and we brought Winston Ho to our Department of Chemical Engineering as a new, for us, member of the National Academy of Engineering.

Our academic program goals: 1) build research areas of major opportunity, and 2) create at least one major nationally recognized multidisciplinary center within five years. To move along with that goal, there are a number of multidisciplinary initiatives in progress at the present time. The two which were selected as top priority for our Academic Plan are: 1) the Biomedical Research Initiative is a complete plan for establishing an innovative structure for biomedical research and for doubling the biomedical research program; and 2) develop a realistic business plan for building facilities and hiring faculty that uses primarily outside resources. This is a wonderful example of how to move forward rapidly and in a very well organized way.

The Kirwan Institute for Race and Ethnicity in the Americas has been carefully planned for some time and has substantial University support. Its director, John Powell, will be arriving on campus at the beginning of the year. This is an institute whose work will certainly be outstanding and world leading.

This past year, the Mathematical Biosciences Institute was established by a grant from the National Science Foundation. This is one of our nation's major national mathematics institutes. This Institute involves people from mathematics, biosciences, and medicine. It is the result of a strategic hire of three related faculty, one of whom is Joel Saltz, in math, medical informatics, and pharmacology. The principal investigator for that program and the director of the Institute is Avner Friedman, mathematics professor and one of the leading members of the National Academy of Sciences in Mathematics.

Our Knowledge Bank Initiative is under the leadership of Joe Brannon. He is defining the role of research universities as providers of information in our knowledge economy. This is an initiative which is just getting off the ground, but one where the rest of the world is following us as rapidly as they can and is being imitated around the globe.

For some time we have been leaders, thanks to the work of the Thompsons and the Byrd Polar Research Center, in climate records from ice cores. Programs in carbon sequestration and the restoration of the Mississippi River Basin are in their early stages, as is our program in international and homeland security.

The quality of our lives and ability to live together in harmony on our planet will depend a great deal on the work of our colleagues in humanities, arts, and social sciences. Here you see Professor Timothy Gregory with a Roman mosaic that he excavated to help him reconstruct the history of how human society and the natural environment have evolved together in the past. It is not difficult to

PRESENTATION ON RESEARCH – DRIVER FOR THE ACADEMIC PLAN (contd)

Dr. Moore: (contd)

imagine that an understanding of how people in the past have evolved with a changing environment will help us deal with the changes that are occurring in our environment today.

In this slide we see a system for digitally recording the motion of dancers. The Ohio State motion capture technology that you see here helps make movies such as *Star Wars* and does lots of interesting other things. Some of you had the pleasure of hearing Sherri Geldin describe the emotional power of a William Forsythe dance on the occasion of his receiving the Wexner Prize that President Holbrook mentioned earlier. We wonder: Could an analysis of the digital record reveal the key elements of Forsythe's impact? Would we find correlations between the motions of dancers and the magnetic resonance images of Forsythe's brain activity? Would this prospect help to lure Forsythe to Columbus? He has lost his funding in Frankfort, so maybe we should take advantage of that. What impact could this research have on our lives? Could it be more expensive to do research in the arts than in physics? Well, this is for the future.

Our second major academic program goal is a push for major new State of Ohio research funding. Last year, I was uncertain about this, but this year, with a \$1.6 billion Third Frontier program flying on the Governor's flag, I'm very optimistic about this. And, of course, through the tobacco monies we have already had a very successful start, from Ohio State's point of view, with funding from this program. We have the first aliquot of \$50 million for the Wright Center of Innovation that has already been allocated by the legislature. In fact, I think the second one came out a couple days ago when the capital budget passed the legislature. So, we're doing well there.

We also want to raise at least \$100 million in new private support by 2005. Frankly, I would really like to see us raise one or two individual chunks of that magnitude. This is an enterprise where we are not yet close to success, but we're not that close to 2005 yet either.

Doubling federal research support from the FY 1999 level by FY 2004. Here we are in really good shape. With respect to NIH funding you will see that we are here in the middle of the pack with respect to our benchmark institutions. We have been improving our performance relative to the rest of the world, moving from the 57th rank to the 53rd rank among all universities, public and private, in the United States. We can expect to improve in this ranking when the 2002 rankings come out, because our NIH funding over the last year has increased by over 22 percent.

With respect to the National Science Foundation, we're still at the bottom among our benchmark institutions. Our performance relative to the rest of the world has been improving, going from 53rd to 46th to 43rd. I expect to see a dramatic improvement in this area next year, because our NSF funding increased over 35 percent. This is an amazing record and I could hardly have dreamed of such improvement, never mind predicted it. These NIH and NSF awards are particularly important because they not only represent dollars to support our research, but, at least as importantly, they represent the opinion of the toughest reviewers in the world of the quality of the work that we do here and their expectations for what we will accomplish in the future.

Research facilities are a really critical component of being able to do research and the efforts that we're going to do to build the biomedical research tower is an obvious example. We're involved in a campus-wide research facilities planning

PRESENTATION ON RESEARCH – DRIVER FOR THE ACADEMIC PLAN (contd)

Dr. Moore: (contd)

process, together with a consultant and the architect's office, which is in mid-course. A research-based survey for facilities -- that is critical to the success of our overhead negotiations -- and bringing in overhead funds for our facilities is moving along and will need to be completed for that spring negotiation.

Building Ohio's future is what we are all about. Moving new knowledge technologies created by research into applications, so as to capture the full value of research for the citizens of Ohio, the nation, and the world. That is a good indicator of how well we are doing. The fact that we are ranked 5th in the nation with respect to the funding of our research by business and industry is how much our research is valued in the practical arena.

A critical part of our job is to provide clear paths for faculty to protect and commercialize their intellectual property. Since the departure of David Allen, we have been revamping our office under the leadership of David Winwood to connect more closely with the faculty. We expect we will be roughly doubling the number of invention disclosures in the next few years and that that will drive the number of patents awarded and the number of license options executed. You will see a dip here in licenses executed and we expect that to recover pretty quickly as our new staff gets busy with our existing intellectual property.

The formation of start-up companies has been a high priority over the last few years and the success in FY 2001 and 2002 has been outstanding. A serious financial problem for us comes through our bottom line in an unfortunate way. On the other hand, making a profit from doing patents and licenses is perhaps not as important as the technology that we transfer and its impact on business and industry in Ohio.

Those of you who watch football know that we have a research program that our football team likes to brag about. A top ranking takes longer to achieve in research than it does in football; the time scales move more slowly, so it's easier to hang in there, too. As in football, though, focus, sustained effort, and an absolute insistence on excellence will allow us to reach our goals.

One of the ways that we'll be reaching our goals is through the work of Professor Joel Saltz, chair of the Department of Medical Informatics. Joel is one of these really modern people – he has an M.D. degree, has done a residency in pathology, and holds a Ph.D. degree in computer science. We simplified his job a little bit. He was a professor at both Johns Hopkins and at the University of Maryland. So let me turn this over to Joel.

BUILDING A CLINICAL RESEARCH GRID

Dr. Joel H. Saltz:

Thank you, Brad. I'm delighted to be here. The topic of biomedical informatics sometimes seems a little difficult to explain. Boiling it down to essentials, what it comes down to is finding needles in haystacks, and finding medical cures from huge amounts of information.

About 300 years ago, the microscope was invented and about 20 years ago it was discovered that most ulcers were due to a bacteria that could have been seen in one of the first microscopes. So it was about 280 years, plus or minus a few years, during which time the tools and really a lot of the data was available to discover the cause of a very common disease.

PRESENTATION ON RESEARCH – DRIVER FOR THE ACADEMIC PLAN (contd)

BUILDING A CLINICAL RESEARCH GRID (contd)

Dr. Saltz: (contd)

Life has gotten a lot more exciting now. As I'm sure you know, there is a huge onslaught of information on genetics, protein expression, and functional imaging. The real challenge is to not be in a situation where, in the year 2300, we say, "You know in 2002 we basically had cancer and heart disease sorted out, but it took a few hundred years to put the pieces together."

This is the goal of the project that a team of folks submitted to the state for the tobacco settlement fund grant. We were delighted to receive that and we're beginning work on this now. The goal in a nutshell is to put together the infrastructure needed to harness information from the many crucial information sources in order to do clinical research to find cures for diseases.

Before I get into that I'm going to say a few things about the partnership, because it is a very exciting partnership. At The Ohio State University, we have an interdisciplinary group, many of whom have been brought in by Fred Sanfilippo in the last couple of years, covering the areas of pharmacogenomics, bioinformatics, various areas of cancer research, heart disease research, and high-end computing and grid computing.

The Ohio Super Computing Center is really a top-notch organization and is one of the many reasons I came to Ohio from the State of Maryland. They are on the leading edge in a lot of very exciting ways and actually a very deep interest in bioinformatics themselves. Recentress is led by a group of people who have been known for many years as some of the leading people in the area of bioinformatics. So, it's a very exciting team to be privileged to work with.

The bottom line here is to synthesize -- to take the dramatic advances that have come and are coming very rapidly in the ability to understand the biological world, to understand what's going on with people's genomes, to understand what's going on with the expression of genes and proteins, and taking whole body and whole animal images and understand what's going on in metabolism -- and put all of this together to understand what this has to do with diseases. So the bottom line is to decrease the cost of clinical research, to increase the ability to synthesize new information, increase effectiveness of treatment, and decrease time to cure disease. The goals are simple and, I think, that augurs well for a project and helps to know where you're going.

One collection of data type involved genetics. There are lots and lots of data sources that range from information on SNPs and haplotypes that increasingly are going to make it possible to individualize medicine, instead of treating a very general disease entity to find out what exactly is going on with an individual person and how that can be dealt with. As you can imagine, there is a very large heterogeneous set of data involved in that.

Then there is intermediate information describing how genes are expressed and how proteins are expressed, and then there is synthetic whole body information, which tells how metabolism is occurring. What this picture shows is a type of MR that is useful for producing tumor grades without taking biopsies. It's a long story as to how it works, but it really tells, essentially, how a tumor is functioning.

So we're taking that and combining that with very exciting advances in computer science. It's a huge problem. What we're really doing is we're standing at a fulcrum, in a sense that we're leveraging ongoing work in computer science and supercomputing and grid computing. We're involved with essentially all of the

PRESENTATION ON RESEARCH – DRIVER FOR THE ACADEMIC PLAN (contd)

BUILDING A CLINICAL RESEARCH GRID (contd)

Dr. Saltz: (contd)

major consortia involved in developing this technology. Our role is in small part to develop a little bit of the computer science technology and in large part is to take advances in computer science technology and advances in biomedical research and marry them in order to produce the tools needed to not wait another 300 years to find cures for diseases. This briefly challenges what is important in the needle in a haystack dealing with huge amounts of information.

We're going from a situation where when I was in medical school you could put essentially all of the information associated with a hospital and with all clinical research on one hard drive of a current PC. So things have grown tremendously since then. Data is very large and there are lots of different types of data. In all of this, we have to develop methods for analyzing this data while maintaining patient confidentiality and being able to accommodate research going on at lots of different institutions who may not talk to each other every day. There are problems of scale and in a number of different dimensions.

I want to give you a concrete example of the type of project that's motivating this research. There are many biomedical projects that are associated with this grant, but I think that this project brings some of it home. The issue here is understanding, in essence, how to carry out individualized prevention and treatment of heart disease. That is a pretty basic issue. The question really is, "How does the process of developing heart disease differ from one type of person to another?" "How does a person's genetic makeup affect responses to say for instance treatment by Lipitor?" Because the situation now is that you take a bunch of people who might have high cholesterol and you treat them with Lipitor, or whatever your favorite statin is, and their cholesterol is generally lowered. But some people will have heart attacks anyway.

So what's going on here? How do we go from very general average sorts of statistics to really understand what is going on with disease mechanisms and the relationship between the disease mechanisms and genetics? That involves correlating a lot of information.

One of the exciting things about this is the group of partners involved, because we've taken the rather heterogeneous interdisciplinary team in the original tobacco grant and we've added additional researchers, both in the medical center and on main campus. So there are people in this group who span genetics, who span proteomics, who are in multiple different departments -- pharmacogenomics, cardiology and the like -- as well as Avner Friedman from the Mathematical Sciences Institute. I think this is a really nice example of a very broad team. We're working with a number of such teams.

One of the other exciting things about this process is something that Brad will like and that is that it has the effect of leveraging and making it easier to obtain other funding. All of these researchers are well funded already, but by being able to focus efforts in this interdisciplinary way, we're in a position to both make progress and also present a very convincing description of what we're doing to funding agencies.

The bottom line is that this project will have the attributes that we intended: 1) to improve medical and computing technology, and 2) having an impact on making it easier to do clinical research. Then there's an economic impact, which is also very important to us. By developing software and techniques that make it easier and cheaper to do better clinical research through our partner, Recentress, and

PRESENTATION ON RESEARCH – DRIVER FOR THE ACADEMIC PLAN (contd)

BUILDING A CLINICAL RESEARCH GRID (contd)

Dr. Saltz: (contd)

other partners -- who we will no doubt work with in the course of the grant -- we help seed a software industry that will play in this very economically important area of clinically research and drug discovery. Thank you.

Dr. Moore:

Thanks very much, Joel. Mr. Chairman, thank you.

Mr. Patterson:

Are there any questions? Thank you very much, we appreciate your report.

--0--

STUDENT RECOGNITION AWARD

Ms. Habib:

The Student Recognition Award is presented each month by the Board of Trustees to a student in honor of the student's achievement in his or her area of study, service to the University and/or community, and research achievements that have been a credit to the college and the University.

This month's recipient is Courtney Howard, who was nominated by Dean Hogan in the Colleges of the Arts and Sciences. Dean Hogan was unable to attend today, so Dean Adelson, who is the associate executive dean of Arts and Sciences is here to represent the college.

Courtney is an honor's student majoring in English and minoring in political science. She will graduate this spring, Summa Cum Laude with honors in the liberal arts and with distinction in English, and plans to attend law school next fall. She came to Ohio State in Autumn 1999 as the recipient of a Traditions Scholarship and has been awarded a number of other scholarships since that time. Last year, she was named the College of Humanities' Outstanding Student and also received the Katherine Hall Prize for Leadership, Academic Achievement, and Service.

She is a member of Phi Beta Kappa, Phi Kappa Phi, the National Society of Collegiate Scholars, Student Alumni Council, and Mortarboard Senior Class Honorary. Courtney is also a past member of the Chimes Junior Class Honorary, the symphonic choir, and the women's glee club.

In addition to her academic achievements and her co-curricular activities, Courtney has found time to participate in University governance in a variety of ways. She has served on the Elections Governance Board for the Undergraduate Student Government, and currently serves on the College of Humanities' Dean's Advisory Council, the Colleges of the Arts and Sciences Honors Committee, the Botoman Outstanding Faculty Award Committee, and the NCAA Committee on Academic Integrity.

Courtney has also sought out ways to enhance the quality of her academic experience at Ohio State. In addition to participating in the honors program throughout her time here, she participated in the Bath Study Abroad Program in

STUDENT RECOGNITION AWARD (contd)

Ms. Habib: (contd)

the summer of 2001, and will spend next quarter in Washington, D.C., as a John Glenn Fellow.

Being a student myself, it is a great honor for me to be able to present a student like Courtney to the Board of Trustees. The Board appreciates the chance to meet students, especially ones who exemplify exactly how bright and committed they are at Ohio State.

Congratulations, Courtney. Dean Adelson, would you like to make any comments?

Dean Edward H. Adelson:

Thank you. We are very proud of Courtney. It should be noted that Dr. Frantz is her advisor.

Mr. Patterson:

Congratulations, Courtney. You are truly outstanding.

--0--

CONSENT AGENDA

President Karen A. Holbrook:

We have twelve resolutions on the Consent Agenda today and we are seeking your approval of the following:

NAMING OF LEARNING CENTER

Resolution No. 2003-63

Synopsis: Naming of the Learning Center in Means Hall, rooms 305 and 307, at 1654 Upham Drive is proposed.

WHEREAS the Department of Surgery has created a facility which enhances the transmission of medical research, the interaction of medical staff and students, the access to the medical library and the internet, the hosting of visiting lecturers and small professional conferences; and

WHEREAS Dr. Larry C. Carey served as chair of the Department of Surgery at The Ohio State University from 1975 to 1985; and

WHEREAS Dr. Carey is an outstanding medical professor, having trained numerous other doctors including five who went on to become chairs of surgery departments at other colleges in the United States; and

WHEREAS Dr. Carey is a noted international authority and scholar in biliary and pancreatic surgery; and

WHEREAS the naming of this learning center is suggested and endorsed by legions of Dr. Carey's former residents, medical students, and colleagues:

NAMING OF LEARNING CENTER (contd)

NOW THEREFORE

BE IT RESOLVED, That in accordance with paragraph (F) of rule 3335-1-08 of the Administrative Code the aforementioned facility shall be named the "Lawrence Campbell Carey Learning Center" at The Ohio State University's College of Medicine and Public Health.

NAMING OF OPTOMETRY RESEARCH CLINIC

Resolution No. 2003-64

Synopsis: Naming of the research clinic located in Glenn A. Fry Hall at The Ohio State University College of Optometry, 352 West 10th Avenue is proposed.

WHEREAS E.F. Wildermuth formed a family foundation charged with propagating his optometric mission; and

WHEREAS The E.F. Wildermuth Foundation, based in Ohio, seeks to further optometric research and scholarship; and

WHEREAS E.F. Wildermuth exemplified the integrity and dedication to serving patients and the broader community that is desired in all optometry students; and

WHEREAS in treating all patients with dignity and respect, E.F. Wildermuth desired to find a cure for blindness; and

WHEREAS his family wishes to perpetuate his service to the profession of optometry; and

WHEREAS The E.F. Wildermuth Foundation has been a long-time generous donor to the College of Optometry;

NOW THEREFORE

BE IT RESOLVED, That in accordance with paragraph (F) of rule 3335-1-08 of the Administrative Code the aforementioned facility shall be named the "E.F. Wildermuth Optometric Research Clinic" at The Ohio State University's College of Optometry.

AMENDMENTS TO THE RULES OF THE UNIVERSITY FACULTY

Resolution No. 2003-65

Synopsis: Approval of the following amendments to the *Rules of the University Faculty* are recommended.

WHEREAS the University Senate pursuant to rule 3335-1-09 of the Administrative Code is authorized to recommend through the President to the Board of Trustees the adoption of amendments to the *Rules of the University Faculty* as approved by the University Senate; and

WHEREAS the proposed changes in the *Rules of the University Faculty* were approved by the University Senate on November 14, 2002:

AMENDMENTS TO THE RULES OF THE UNIVERSITY FACULTY (contd)

Rescinded Rule

~~3335-5-483 Committee on university bookstores.~~

~~(A) Membership.~~

~~The committee on university bookstores shall consist of eleven members.~~

~~(1) Five regular faculty, one of whom is a member of the university libraries, selected by the faculty council. The term of service is three years.~~

~~(2) Four students.~~

~~(a) One graduate student selected by the council of graduate students. The term of service is one year.~~

~~(b) One professional student selected by the inter-professional council. The term of service is one year.~~

~~(c) Two undergraduate students selected by the undergraduate student government. The term of service is one year.~~

~~(3) Two administration members, non-voting.~~

~~(a) Vice president for business and finance or designee.~~

~~(b) Director, the Ohio state university bookstores.~~

~~(B) Duties and responsibilities.~~

~~(1) Review short- and long-term plans and objectives recommended by the management of the Ohio state university bookstores and, in cooperation with that management develop, revise, and recommend basic policies, programs, and objectives. These would include, but not be limited to:~~

~~(a) Reviewing proposals to open or close branches.~~

~~(b) Monitoring and reporting to the senate periodically on the financial status of the bookstores.~~

~~(c) Recommending actions that promote the scholarly nature of the bookstores.~~

~~(d) Developing policies that enhance the timely availability of both new and used textbooks.~~

~~(e) Recommending changes to maintain adequate educational materials, services, and organization.~~

~~(2) Make recommendations on these matters to the director of the Ohio state university bookstores, and to the university senate as appropriate. The vice president for business and finance, the senior vice president for business and finance, and the office of the university senate shall be notified of these recommendations.~~

~~(C) Organization.~~

~~As a standing committee of the senate, this committee is also governed by the provisions of rules 3335-5-46 and 3335-5-48 of the Administrative Code. (B/T 5/1/86, B/T 10/2/87, B/T 2/5/88, B/T 2/4/93, B/T 11/4/94, B/T 12/4/98, B/T 12/6/2002)~~

AMENDMENTS TO THE RULES OF THE UNIVERSITY FACULTY (contd)

NOW THEREFORE

BE IT RESOLVED, That the foregoing amendments to the *Rules of the University Faculty* be adopted as recommended by the University Senate.

HONORARY DEGREES

Resolution No. 2003-66

Synopsis: The awarding of honorary degrees is recommended for approval.

WHEREAS the Committee on Honorary Degrees and the University Senate, pursuant to rule 3335-5-488 of the Administrative Code, have approved for recommendation to the Board of Trustees awarding of honorary degrees as listed below:

Robert D. Havener	Doctor of Public Service
Gerardus 't Hooft	Doctor of Science
Martha C. Nussbaum	Doctor of Humane Letters
Mark Rucker	Doctor of Music
Robert Edward "Ted" Turner III	Doctor of Humane Letters

and

WHEREAS pursuant to paragraph (B)(4) of rule 3335-1-03 of the Administrative Code, the President, after consultation with the Steering Committee of the University Senate, recommended to the Board of Trustees awarding of an honorary degree as listed below:

Louis W. Sullivan	Doctor of Public Health
-------------------	-------------------------

NOW THEREFORE

BE IT RESOLVED, That the above honorary degrees be awarded in accordance with the recommendation at a time convenient to the University and the recipients.

DEGREES AND CERTIFICATES - AUTUMN QUARTER COMMENCEMENT

Resolution No. 2003-67

Synopsis: Approval of Degrees and Certificates for Autumn Quarter is proposed.

WHEREAS pursuant to paragraph (E) of rule 3335-1-06 of the Administrative Code, the Board has authority for the issuance of degrees and certificates; and

WHEREAS the faculties of the colleges and schools shall transmit, in accordance with rule 3335-9-29 of the Administrative Code, for approval by the Board of Trustees the names of persons who have completed degree and certificate requirements:

NOW THEREFORE

DEGREES AND CERTIFICATES - AUTUMN QUARTER COMMENCEMENT (contd)

BE IT RESOLVED, That the degrees and certificates be conferred on December 13, 2002, to those persons who have completed the requirements for their respective degrees and certificates and are recommended by the colleges and schools, and that the names of those persons awarded degrees and certificates be included in the minutes of this meeting.

PERSONNEL ACTIONS

Resolution No. 2003-68

BE IT RESOLVED, That the personnel actions as recorded in the Personnel Budget Records of the University since the November 1, 2002 meeting of the Board, including the following Appointments, Appointment/Reappointment of Chairpersons, Promotion, Leaves of Absence Without Salary, Professional Improvement Leaves, Professional Improvement Leave—Change in Dates, and Emeritus Titles as detailed in the University Budget be approved.

BE IT FURTHER RESOLVED, That the Medical Staff Appointments approved November 19, 2002, by The James Cancer Hospital Board, be ratified.

Appointments

Name: DANIEL C.K. CHOW
Title: Professor (The Robert J. Nordstrom Designated Professorship in Law)
College: Law
Term: December 6, 2002, through November 30, 2007

Name: SHARON L. DAVIES
Title: Professor (The John C. Elam/Vorys Sater Designated Professorship in Law)
College: Law
Term: December 6, 2002, through November 30, 2007

Name: CHARIS ENG
Title: Professor (The Klotz Chair in Cancer Research)
College: Medicine and Public Health (The James Cancer Hospital and Richard J. Solove Research Institute)
Term: December 1, 2002, through June 30, 2006

Name: DAVID O. FRANTZ
Title: Secretary of the Board of Trustees
Office: Board of Trustees
Effective: December 6, 2002
Concurrent Position: Professor, Department of English

Name: P. CHRIS HAMMEL
Title: The Ohio Eminent Scholar in Experimental Materials Research
College: Mathematical and Physical Sciences
Effective: October 1, 2002
Present Position: Laboratory Fellow, Los Alamos National Laboratory, Los Alamos, NM

Name: ALAN C. MICHAELS
Title: Professor (The Edwin M. Cooperman Designated Professorship in Law)
College: Law
Term: December 1, 2002, through June 30, 2006

PERSONNEL ACTIONS (contd)

Appointments (contd)

Name: MARY E. O'CONNELL
Title: Professor (The Honorable William B. Saxbe Designated Professorship in Law)
College: Law
Term: December 1, 2002, through June 30, 2007

Name: ALLAN J. SAMANSKY
Title: Professor (The Robert J. Watkins/Procter & Gamble Professorship Fund)
College: Law
Term: December 6, 2002, through November 30, 2007

Name: BARBARA R. SNYDER
Title: Interim Vice President
Office: University Relations
Effective: December 1, 2002
Present Position: Vice Provost, Office of Academic Affairs

Name: ANDREAS F. VON RECUM
Title: Director of Biomedical Engineering Center
College: Engineering
Term: August 17, 2002, through August 16, 2007
Concurrent Position: Associate Dean, College of Veterinary Medicine

Appointment of Chairperson

July 1, 2003, through June 30, 2007

Geography

Morton E. O'Kelly

Reappointment of Chairpersons

July 1, 2003, through June 30, 2007

Political Science
Speech and Hearing Science

Paul A. Beck
Robert A. Fox

Promotion

Name: MAUREEN T. SHARKEY
Title: Associate Secretary of the Board of Trustees
Office: Board of Trustees
Effective: December 6, 2002
Present Position: Assistant Secretary of the Board of Trustees

Leaves of Absence Without Salary

MOHAMMED I. EL-NAGGAR, Professor, Department of Electrical Engineering, to assist Spirea Microelectronics with product development and help manage the U.S. operation, effective Autumn Quarter 2002, Winter Quarter and Spring Quarter 2003.

BERYL A. MILLER, Professor, Department of Dance, effective Autumn Quarter 2002, to work as Artistic Director of Bebe Miller Company.

DAVID A. ODDEN, Professor, Department of Linguistics, effective Winter Quarter and Spring Quarter 2003, to accept a visiting professorship at Durham University, United Kingdom.

PERSONNEL ACTIONS (contd)

Leaves of Absence Without Salary (contd)

KIRK A. DENTON, Associate Professor, Department of East Asian Languages and Literatures, effective April 1, 2003, through June 30, 2003, to accept a visiting associate professorship at Harvard University.

REBEKAH MODRAK, Assistant Professor, Department of Art, effective Winter Quarter 2003, for personal reasons.

Professional Improvement Leaves

KENNETH W. HINCHCLIFF, Professor, Department of Veterinary Clinical Sciences, effective Winter Quarter and Spring Quarter 2003.

MICHAEL J. PARSONS, Professor, Department of Art Education, effective Autumn Quarter 2003, Winter Quarter and Spring Quarter 2004.

KATHRYN A. EATON, Associate Professor, Department of Veterinary Biosciences, effective January 1, 2003, through December 31, 2003.

JOSEPH E. HEIMLICH, Associate Professor, School of Natural Resources, effective Winter Quarter, Spring Quarter, Summer Quarter, and Autumn Quarter 2003.

Professional Improvement Leave—Change in Dates

ANTHONY MUGHAN, Professor, Department of Political Science, change leave from Spring Quarter 2003, to Autumn Quarter 2003.

Emeritus Titles

LARRY B. ANDERSON, Department of Chemistry, with the title Professor Emeritus, effective December 1, 2002.

RICHARD N. CHRISTENSEN, Department of Mechanical Engineering, with the title Professor Emeritus, effective December 1, 2002.

VERNAL H. KENNER, Department of Mechanical Engineering, with the title Professor Emeritus, effective December 1, 2002.

DOUGLAS S. KERR, Department of Computer and Information Science, with the title Associate Professor Emeritus, effective December 1, 2002.

WILLIAM F. OGDEN, Department of Computer and Information Science, with the title Associate Professor Emeritus, effective December 1, 2002.

Medical Staff—Appointments (The Arthur G. James Cancer Hospital and Richard J. Solove Research Institute)

October/November 2002

Initial Appointments – Faculty

Yiu-Chung Chan, M.D., Psychiatry, Assistant Professor, Associate Attending
Gregory A. Christoforidis, M.D., Radiology, Assistant Professor, Associate Attending
Marcella Dardani, D.O., Radiology, Assistant Professor, Associate Attending
Galina T. Dimitrova, M.D., Anesthesiology, Clinical Assistant Professor, Associate Attending
Maria Estrada, D. O., Pediatric Critical Care, Associate Attending
Richard A. Freeland, M.D., Psychiatry, Associate Professor, Associate Attending

PERSONNEL ACTIONS (contd)

Medical Staff—Appointments (The Arthur G. James Cancer Hospital and Richard J. Solove Research Institute (contd)

October/November 2002 (contd)

Initial Appointments – Faculty (contd)

Pablo A. Gamboa, M.D., Radiology, Assistant Professor, Associate Attending
Hooman Khabiri, M.D., Radiology, Assistant Professor, Associate Attending
Nadeem Khan, M.D., Pediatric Critical Care, Associate Attending
Mark A. King, M.D., Radiology, Assistant Professor, Associate Attending
Lawrence S. Kirschner, M.D., Ph.D., Internal Medicine, Endocrinology, Associate Professor, Associate Attending
Sumant Lamba, M.D., Internal Medicine, Cardiology, Associate Attending
Mary J. McCafferty, M.D., Psychiatry, Clinical Assistant Professor, Associate Attending
Kannan Natarajan, M.D., Radiology, Assistant Professor, Associate Attending
Julie A. Niedermier, M.D., Psychiatry, Assistant Professor, Associate Attending
Autumn M. O'Brien, M.D., Internal Medicine, General Medicine, Clinical Assistant Professor, Associate Attending
Milroy J. Samuel, M.D., Obstetrics and Gynecology, Clinical Instructor, Clinical Attending
H. Wayne Slone, M.D., Radiology, Assistant Professor, Associate Attending
Karen Thomas, D.O., Neurology, Assistant Professor, Associate Attending
Kenneth M. Vitellas, M.D., Radiology, Assistant Professor, Associate Attending
Craig E. Williams, M.D., Psychiatry, Clinical Assistant Professor, Associate Attending
Bruce Woodworth, M.D., Surgery, Urology, Clinical Assistant Professor, Clinical Attending
James L. Young, M.D., Psychiatry, Clinical Assistant Professor, Associate Attending
Joseph Yu, M.D., Radiology, Associate Professor, Associate Attending

Initial Appointments – Community

Jeffrey G. Bell, M.D., Obstetrics and Gynecology, Community Associate based at Riverside Methodist Hospital
Kiran K. Devulapally, M.D., Community Associate based at University Hospitals/East
Grace Hercl, D.O., Internal Medicine, General Medicine, Community Associate based at University Hospitals/East
Thomas E. McElDowney, D.O., Internal Medicine, General Medicine, Community Associate based at University Hospitals/East
Randy L. Mills, D.O., Internal Medicine, General Medicine, Community Associate based at University Hospitals/East
Charles W. Noble, M.D., Internal Medicine, Cardiology, Community Associate based at University Hospitals/East
Jeffrey G. Poulos, M.D., Internal Medicine, General Medicine, Community Associate based at University Hospitals/East
Alex Tambrini, M.D., Family Practice, Community Associate based at The Community Hospital, Springfield
Valerie A. Woodmansee, D.O., Emergency Medicine, Community Associate based at The Community Hospital, Springfield

Initial Appointments – Allied Health Professionals

Jennifer Brown, PA, Surgery, Cardiothoracic Surgery
Ruthann Kennedy, C.N.P., Internal Medicine, Pulmonary and Critical Care

Provisional to Full Appointment – Faculty

Robert Crowell, M.D., Orthopaedics, Associate Attending

PERSONNEL ACTIONS (contd)

Medical Staff—Appointments (The Arthur G. James Cancer Hospital and Richard J. Solove Research Institute (contd)

October/November 2002 (contd)

Provisional to Full Appointment – Community

Richard Gordon, Jr., M.D., Family Practice, Community Associate

Provisional to Full Appointment – Advanced Practice Nurse

Mollie E. Moran, C.N.P., Hematology/Oncology, Allied Health Professional

Change in Staff Category

Sherman Katz, M.D., from Associate Attending to Clinical Attending

John Robinson, M.D., Cardiology, from Associate Attending to Clinical Attending

Additional privileges requested

Conscious sedation:

James Allen, M.D., Pulmonary, Moderate and Deep
Nitin Bhatt, M.D., Internal Medicine, Pulmonary and Critical Care
Lisa Dunn-Albanese, M.D., Obstetrics and Gynecology
Djavid Hadian, M.D., Internal Medicine, Cardiology
Charles Love, M.D., Cardiology, Moderate and Deep
David Quinn, M.D., Internal Medicine, Digestive Diseases
Namita Sood, M.D., Internal Medicine, Pulmonary and Critical Care

Prescriptive Authority:

Tracy Hollar Reugg, C.N.P., Internal Medicine, Hematology/Oncology

Arterial Blood Gases:

Maureen Buckner, C.N.P., Internal Medicine, Hematology/Oncology

RESOLUTIONS IN MEMORIAM

Resolution No. 2003-69

Synopsis: Approval of Resolutions in Memoriam is proposed.

RESOLVED, That the Board adopt the following Resolutions in Memoriam and that the President be requested to convey a copy to the families of the deceased.

Herbert W. Crown

The Board of Trustees of The Ohio State University expresses its sorrow upon the death on November 17, 2002, of Herbert W. Crown, Professor Emeritus, Ohio State University Extension.

RESOLUTIONS IN MEMORIAM (contd)

Herbert W. Crown (contd)

Mr. Crown was born September 6, 1927, in Nashport, Ohio. He received a Bachelor of Science degree in agriculture from The Ohio State University in 1950 and a master's degree in agricultural economics in 1966, also from The Ohio State University.

He began his Extension career in Ohio in November 1955 as the agricultural agent in Holmes County. In October 1966, he became the farm management area extension agent at the Hillsboro Center, and subsequently assumed the same position at the Mount Gilead Area Center. After 10 years of service at the Mount Gilead office, he became the area supervisor. In 1983, he took the position of farm management extension specialist. He retired as professor emeritus in 1985.

During Mr. Crown's career with Extension he was instrumental in the development of the regional planning commission, dairy information programs for Swiss cheese milk producers, and multi-county dairy and poultry programs, all of which were of great importance to the clientele of Holmes County. In addition, he also developed and presented dairy production seminar programs which were extremely valuable to farm management education in the Mount Gilead and Wapakoneta areas of the state.

He was a member of the Extension fraternity, Epsilon Sigma Phi, and participated in state committees and meetings. Mr. Crown received regional and national recognition for his work in Extension educational programs dealing with farm management. He was awarded the Distinguished Service Award by the National County Agents Association.

These contributions in providing excellent Extension educational programs during his career earned him the respect and admiration of co-workers and associates throughout the state and nation.

On behalf of the University community, the Board of Trustees expresses to the family of Professor Herbert W. Crown its deepest sympathy and sense of understanding of their loss. It was directed that this resolution be inscribed upon the minutes of the Board of Trustees and that a copy be tendered to his family as an expression of the Board's heartfelt sympathy.

Edward F. Donovan

The Board of Trustees of The Ohio State University expresses its sorrow upon the death on October 15, 2002, of Dr. Edward F. Donovan, Professor Emeritus in the Department of Veterinary Clinical Sciences.

Dr. Donovan was a World War II veteran who served in the U.S. Army Air Corps from 1940-1945 as a first lieutenant pilot. A Columbus, Ohio, native, he enrolled in the College of Veterinary Medicine at The Ohio State University after the war, and received the Doctor of Veterinary Medicine degree in 1949. Following graduation, he practiced veterinary medicine in a private veterinary hospital and was employed as a clinical researcher at American Cyanamid Company in New York. Dr. Donovan returned to The Ohio State University in 1956 as an assistant professor of small animal internal medicine in the College of Veterinary Medicine. After 27 years of distinguished service on the faculty, Dr. Donovan retired from the Department of Veterinary Clinical Sciences where he was professor and acting department chair.

Over the years, his clinical interests included internal medicine and ophthalmology. Dr. Donovan conducted research studies on the normal anatomy of the canine eye and retinopathies associated with low-level radiation. The results of his research were published in various scientific journals, text book chapters, and a book by the Atomic Energy Commission.

Edward Donovan served his profession at the highest level. He was a member of the American Animal Hospital Association Committee on Ophthalmology, the American Veterinary Medical

RESOLUTIONS IN MEMORIAM (contd)

Edward F. Donovan (contd)

Association, and the Ohio Veterinary Medical Association. He was a charter diplomate of the specialty of internal medicine in the American College of Veterinary Internal Medicine, and he served as secretary of this national organization. He also served as national director of research for the Morris Animal Foundation. In 1970 he was recipient of the Norden Distinguished Teacher Award, which is the highest honor for teaching excellence awarded by the College of Veterinary Medicine.

Dr. Donovan was also an active member of the University community and served on various College committees including the Veterinary Teaching Hospital Board, the Finance Committee, and the Service and Safety Committee.

On behalf of the University community, the Board of Trustees expresses to the family of Professor Edward F. Donovan its deepest sympathy and sense of understanding of their loss. It was directed that this resolution be inscribed upon the minutes of the Board of Trustees and that a copy be tendered to his family as an expression of the Board's heartfelt sympathy.

REPORT OF RESEARCH CONTRACTS AND GRANTS

Resolution No. 2003-70

Synopsis: The report on research and other sponsored program contracts and grants and the summary for October 2002 is presented for Board acceptance.

WHEREAS monies are solicited and received on behalf of the University from governmental, industrial, and other agencies in support of research, instructional activities, and service; and

WHEREAS such monies are received through The Ohio State University Research Foundation:

NOW THEREFORE

BE IT RESOLVED, That the research agreement between The Ohio State University and The Ohio State University Research Foundation for the contracts and grants reported herein during the month of October 2002 be approved.

REPORT ON UNIVERSITY DEVELOPMENT

Resolution No. 2003-71

Synopsis: The report on the receipt of gifts and the summary for October 2002 are presented for Board acceptance.

WHEREAS monies are solicited and received on behalf of the University from alumni, industry, and various individuals in support of research, instructional activities, and service; and

WHEREAS such gifts are received through The Ohio State University Development Fund and The Ohio State University Foundation; and

WHEREAS this report includes the establishment of The University Chair in Economics, The University Chair in Macroeconomics/Monetary Economics, The James G. (Jim) and Sue A. Oates Designated Professorship in Business, The John C. Elaim/Vorys Sater Designated Professorship in Law, and The Robert J. Nordstrom Designated Professorship in Law; and

REPORT ON UNIVERSITY DEVELOPMENT (contd)

WHEREAS this report includes the establishment of eighteen (18) new named endowed funds and the amendment of three (3) named endowed funds:

NOW THEREFORE

BE IT RESOLVED, That the acceptance of the report from The Ohio State University Development Fund and The Ohio State University Foundation during the month of October 2002 be approved.

TOTAL UNIVERSITY PRIVATE SUPPORT

July through October
2001 Compared to 2002

GIFT RECEIPTS BY DONOR TYPE

	Dollars July through October		
	<u>2001</u>	<u>2002</u>	<u>%Change</u>
Individuals:			
Alumni (Current Giving)	\$6,050,265	\$9,274,014	53
Alumni (From Bequests)	<u>1,876,712</u>	<u>1,563,955</u>	(17)
Alumni Total	\$7,926,977	\$10,837,969	37
Non-Alumni (Current Giving)	\$3,621,221	\$4,797,675	32
Non-Alumni (From Bequests)	<u>1,107,441</u>	<u>3,084,131</u>	178
Non-Alumni Total	\$4,728,662	\$7,881,806	67
Individual Total	\$12,655,639	\$18,719,775	48 ^A
Corporations/Corp/Foundations	\$12,817,546	\$15,348,472	20 ^B
Private Foundations	\$4,438,054	\$2,325,051	(48) ^C
Associations and Other Organizations	<u>\$1,297,440</u>	<u>\$1,284,430</u>	<u>(1)</u>
Total	\$31,208,679	\$37,677,728	21

NOTES

- A Individual giving is up 48% largely due to the fact that gifts of \$10,000 or more are up 64% (139 gifts for \$9.0 million last year; 161 gifts for \$14.8 million this year).
- B Gifts at the \$10,000 or more level from corporations are up 23% for July-October compared with the same period last year (226 gifts for \$10.7 million last year; 235 gifts for \$13.2 million this year).
- C Foundation giving at the \$10,000 or more level is down 100% for the first quarter of the fiscal year (\$2.1 million from 49 gifts this year; \$4.2 million from 57 gifts last year).

REPORT ON UNIVERSITY DEVELOPMENT (contd)

TOTAL UNIVERSITY PRIVATE SUPPORT (contd)

July from October
2001 Compared to 2002

GIFT RECEIPTS BY PURPOSE

	Dollars July through October		
	<u>2001</u>	<u>2002</u>	<u>% Change</u>
Gift Receipts to Current Use and Endowment Funds:			
Buildings/Equipment	\$4,369,546	\$4,860,782	11
Faculty Support	\$1,665,875	\$3,038,695	82
Program Support	\$18,421,810	\$20,881,628	13
Student Financial Aid	\$4,167,337	\$6,441,628	55
Annual Funds-Colleges/Departments	\$2,437,369	\$2,305,331	(5)
Annual Funds-University	<u>\$146,742</u>	<u>\$149,664</u>	<u>2</u>
Total	\$31,208,679	\$37,677,728	21

GIFT ADDITIONS TO ENDOWMENT

Dollars
July through October

<u>2001</u>	<u>2002</u>	<u>% Change</u>
\$8,688,048	\$13,412,621	54

REPORT ON UNIVERSITY DEVELOPMENT (contd)

THE OHIO STATE UNIVERSITY DEVELOPMENT FUND

	<u>Previous Gifts</u>	<u>Current Gifts</u>	<u>Total Gifts</u>
<u>Establishment of University Chairs</u>			
The University Chair in Economics (Distinguished professor and scholar in the Department of Economics)			
The University Chair in Macroeconomics/ Monetary Economics (Distinguished professor and scholar in the Department of Economics)			
<u>Establishment of Named Designated Professorship</u>			
James G. (Jim) and Sue A. Oates Designated Professorship in Business (Used to support a faculty member in the Fisher College of Business; provided by gifts from James G. and Sue A. Oates) (\$187,500 over five years)			
<u>Establishment of Named Endowed Funds</u>			
The George, Elsa, and Louise Carroll Athletic Scholarship Fund (Used to support student athlete scholarships for members of The OSU varsity football team; provided by gifts from William Carroll)		\$250,000.00	\$250,000.00
The Lawrence J. Mervis, M.D. Endowed Fund in Neurosurgery (Used to provide support for neurosurgery; provided by gifts from the family of Dr. Lawrence J. Mervis)		\$70,000.00	\$70,000.00
<u>Change in Description of Named Endowed Fund</u>			
The Raymond D. Hammond Chemical Engineering Scholarship Fund			

THE OHIO STATE UNIVERSITY FOUNDATION

	<u>Previous Gifts</u>	<u>Current Gifts</u>	<u>Total Gifts</u>
<u>Establishment of Named Designated Professorships</u>			
The John C. Elam/Vorys Sater Designated Professorship in Law (Used to support a professorship in the Moritz College of Law; provided by gifts made by Moritz College of Law alumni employed by Vorys Sater Seymour &Pease) (\$37,500 per year for five years)			

REPORT ON UNIVERSITY DEVELOPMENT (contd)

THE OHIO STATE UNIVERSITY FOUNDATION (contd)

	<u>Previous Gifts</u>	<u>Current Gifts</u>	<u>Total Gifts</u>
<u>Establishment of Named Designated Professorships (contd)</u>			
The Robert J. Nordstrom Designated Professorship in Law (Used to support a professorship in the Moritz College of Law; provided by gifts made by Moritz College of Law alumni employed by Porter Wright Morris & Arthur) (\$37,500 per year for five years)			
<u>Establishment of Named Endowed Funds</u>			
Gleason Gearing and Power Transmission Research Fund (Used to provide support for research in the Department of Mechanical Engineering; provided by a gift from the Gleason Foundation)		\$182,097.00	\$182,097.00
The Eleanor L. Craig Scholarship Fund (Used to fund a scholarship for an accounting major in the Fisher College of Business; provided by gifts from Eleanor L. Craig)	\$173,606.00		\$173,606.00
The William M. and Darlene Aldrige Scholarship Fund in the College of Human Ecology (Used to support scholarships for students in the College of Human Ecology; provided by gifts from the estate of Darlene Aldrige)		\$150,000.00	\$150,000.00
The Florence B. Andrews Endowment Fund (Used to purchase books, reference materials, etc. for the Main Library; provided by gifts from Henry B. Andrews)		\$150,000.00	\$150,000.00
The Victor King Thompson 1934,1941 and Marianne Randall Thompson 1938 Scholarship Fund in the Knowlton School of Architecture (Used to support a scholarship for a student in the Knowlton School of Architecture; provided by a gift from Victor King Thompson and Marianne Randall Thompson)		\$82,589.00	\$82,589.00
The Aschenbach Athletic Endowment Fund (Used to supplement the scholarship costs of undergraduate members of the men's gymnastics team; provided by gifts from Douglas Aschenbach)		\$75,000.00	\$75,000.00
The Aschenbach Diversity Endowment Fund (Used to fund the recruitment initiatives of The OSU Marching Band to promote diversity; provided by a gift from Douglas Aschenbach)		\$75,000.00	\$75,000.00

REPORT ON UNIVERSITY DEVELOPMENT (contd)

THE OHIO STATE UNIVERSITY FOUNDATION (contd)

	<u>Previous Gifts</u>	<u>Current Gifts</u>	<u>Total Gifts</u>
<u>Establishment of Named Endowed Funds (contd)</u>			
William Edgerton Fillmore Fund for Excellence in Mechanical Engineering (Used to support financing of activities and construction in the Department of Mechanical Engineering; provided by gifts from William Edgerton Fillmore)		\$46,764.33	\$46,764.33
The Lyle Aloysius John Gassmann Memorial Award Fund in Optometry (Used to provide an award in the College of Optometry; provided by gifts from friends, family and classmates)		\$28,701.00	\$28,701.00
The Mynydd Teg Endowment Fund for Cancer Genetics Research (Used to support cancer genetics research; provided by a gift from the Mynydd Teg Family Foundation)		\$25,391.35	\$25,391.35
The Cooper/Siedentop Scholarship Fund (Used to provide dissertation support to students in the College of Education; provided by gifts from an anonymous alumna)		\$25,193.00	\$25,193.00
Brett E. Lahman Scholarship Fund for Engineers (Used to award annual scholarships to students in the College of Engineering; provided by gifts from family and friends)		\$25,153.13	\$25,153.13
The Maurice "Mo" Mullet MD Medical Student/Alumni Forum Fund (Used to support an education forum in the College of Medicine and Public Health; provided by gifts from Maurice E. Mullet)		\$25,034.00	\$25,034.00
The Joseph A. Alutto MBA Scholarship Fund (Used to provide scholarships to MBA students; provided by gifts from Joseph A. Alutto)		\$25,000.00	\$25,000.00
The Carl Kipp Jr. Paygro/Garick Endowed Scholarship Fund (Used to provide scholarships for students in the Department of Food, Agricultural, and Biological Engineering; provided by gifts from Paygro/Garick)		\$25,000.00	\$25,000.00

REPORT ON UNIVERSITY DEVELOPMENT (contd)

THE OHIO STATE UNIVERSITY FOUNDATION (contd)

	<u>Previous Gifts</u>	<u>Current Gifts</u>	<u>Total Gifts</u>
<u>Establishment of Named Endowed Funds (contd)</u>			
The Kourie Family Athletic Scholarship Fund Honoring Ryan Shockley (Used to provide scholarships costs for undergraduate student-athletes on the varsity football team; provided by gifts from Michael J. and Kathryn M. Kourie)		\$25,000.00	\$25,000.00
<u>Change in Name of Named Endowed Funds</u>			
From: The Seubert Family Chadwick Arboretum Guest Lecturer Endowment Fund			
To: The Chadwick Arboretum Guest Lecturer Endowment			
From: The Mary E. Babcock Endowment Fund			
To: The Mary E. Babcock Unrestricted Endowment Fund			
	_____	_____	_____
Total	\$173,606.00	\$1,285,922.81	\$1,459,528.81

THE OHIO STATE UNIVERSITY DEVELOPMENT FUND

Establishment of University Chairs

The University Chair in Economics

The University Chair in Economics was created in 1984 and was established December 6, 2002, by the Board of Trustees of The Ohio State University.

Through a memorandum of understanding between the Office of Academic Affairs, the College of Social and Behavioral Sciences, and the Department of Economics, a pool of general funds annual rate was set aside to support this position in perpetuity.

The general funds spending authority shall be used to provide support for a distinguished professor and scholar whose interests focus in one or more areas of economics. Appointment to the chair will be recommended by the chairperson of the Department of Economics and the dean of the College of Social and Behavioral Sciences to the provost, and approved by The Ohio State University Board of Trustees.

If the need for these funds should cease to exist, then the provost and the dean of the College of Social and Behavioral Sciences shall determine the disposition.

The University Chair in Macroeconomics/Monetary Economics

The University Chair in Macroeconomics/Monetary Economics was created in 1994 and was established December 6, 2002, by the Board of Trustees of The Ohio State University.

REPORT ON UNIVERSITY DEVELOPMENT (contd)

THE OHIO STATE UNIVERSITY DEVELOPMENT FUND (contd)

Establishment of University Chairs (contd)

The University Chair in Macroeconomics/Monetary Economics (contd)

Through a memorandum of understanding between the Office of Academic Affairs, the College of Social and Behavioral Sciences, and the Department of Economics, a pool of general funds annual rate was set aside to support this position in perpetuity.

The general funds spending authority shall be used to provide support for a distinguished professor and scholar whose interests focus in one or more areas of monetary economics and/or macroeconomics. Appointment to the chair will be recommended by the chairperson of the Department of Economics and the dean of the College of Social and Behavioral Sciences to the provost, and approved by The Ohio State University Board of Trustees.

If the need for these funds should cease to exist, then the provost and the dean of the College of Social and Behavioral Sciences shall determine the disposition.

Establishment of Named Designated Professorship

James G. (Jim) and Sue A. Oates Designated Professorship in Business

The James G. (Jim) and Sue A. Oates Designated Professorship in Business was established December 6, 2002, by the Board of Trustees of The Ohio State University. It is being created as a result of a gift in the amount of \$187,500 over five years from James G. (Jim) (B.S.Bus.Adm., 1966) and Sue A. Oates of Gunnison, Colorado.

The annual contributions shall be used to support a faculty member in The Max M. Fisher College of Business who has demonstrated outstanding talent as a teacher and researcher, and has developed strong ties to the business community. Through these activities, the successful candidate will have not only enhanced the overall reputation of the Fisher College of Business, but will have significantly impacted the thinking and practice of managers through broad application of the candidate's ideas and theories. In addition, preference shall be given to a faculty member specializing in the area of marketing. The selection of the James G. (Jim) and Sue A. Oates Professor will be determined by the dean of the Fisher College of Business with the donors.

It is the desire of the donors that this professorship be designated for five years. Should the professorship become vacant after initial selection, the dean will identify another use for the gift in consultation with the donors.

\$187,500.00 over five years

Establishment of Named Endowed Funds

The George, Elsa, and Louise Carroll Athletic Scholarship Fund

The George, Elsa, and Louise Carroll Athletic Scholarship Fund was established December 6, 2002, by the Board of Trustees of The Ohio State University with gifts from William Carroll (B.S. – Journalism, 1933) of Columbus, Ohio, in honor and memory of his parents and wife.

All gifts are to be invested in the University's Permanent Endowment Fund, under the rules and regulations adopted by the Board of Trustees of The Ohio State University, with the right to invest and reinvest as occasion dictates.

REPORT ON UNIVERSITY DEVELOPMENT (contd)

THE OHIO STATE UNIVERSITY DEVELOPMENT FUND (contd)

Establishment of Named Endowed Funds (contd)

The George, Elsa, and Louise Carroll Athletic Scholarship Fund (contd)

The annual income shall be used to support student-athlete scholarships for members of The Ohio State University varsity football team. Selection of the recipients will be made by the director of Athletics in consultation with the University Committee on Student Financial Aid.

It is the desire of the donor that this fund should benefit the University in perpetuity. If the need for this fund should cease to exist or so diminish as to provide unused income, then another use shall be designated by the Board of Trustees as recommended by the director of Athletics in order to carry out the desire of the donor.

\$250,000.00

The Lawrence J. Mervis, M.D. Endowed Fund in Neurosurgery

The Lawrence J. Mervis, M.D. Endowed Fund in Neurosurgery was established December 6, 2002, by the Board of Trustees of The Ohio State University with gifts from Dr. Mervis' wife, Jean, and by their children and grandchildren, given in honor and memory of Dr. Lawrence J. Mervis (B.S., 1958; M.D., 1962), clinical associate professor in the Department of Surgery, Division of Neurosurgery, of Columbus, Ohio.

All gifts are to be invested in the University's Permanent Endowment Fund, under the rules and regulations adopted by the Board of Trustees of The Ohio State University, with the right to invest and reinvest as occasion dictates.

The annual income shall be exclusively used to support the Division of Neurosurgery with preference given to teaching and/or research activities regarding glioblastoma or other malignant brain tumors. Any income earned by the fund prior to the earlier of either July 31, 2007 or the date Neurosurgery is an established department, shall be added to the principal of the fund. Once established as a department, the annual income shall be used exclusively to support the Department of Neurosurgery as approved by the chairperson in consultation with the senior vice president for Health Sciences and dean of the College of Medicine and Public Health.

If after July 31, 2007, Neurosurgery is not an established department, the donor may redirect the use of the fund to another area in the Department of Surgery or in the Department of Neuroscience by an instrument in writing delivered to the University prior to July 31, 2008.

If funding reaches the professorship level of \$750,000, subject to the approval of the Board of Trustees of the University, the University agrees to convert the fund to a professorship and to change the name in perpetuity to The Lawrence J. Mervis, M.D. Professorship in Neurosurgery in the College of Medicine and Public Health for teaching and research in neurosurgery. Support shall be provided to a distinguished neurosurgeon, researcher, teacher or practitioner in the College of Medicine and Public Health for salary, program support, and basic and clinical research. The appointment shall be made at the recommendation of the senior vice president for Health Sciences and dean of the College of Medicine and Public Health in consultation with the director/chairperson of the Division/Department of Neurosurgery with preference to be given to those interested in glioblastoma or other malignant brain tumors.

The activities of the professorship holder shall be reviewed no less than every five years by the senior vice president and dean to determine compliance with the intent of the donor as well as the academic and research standards of the University.

REPORT ON UNIVERSITY DEVELOPMENT (contd)

THE OHIO STATE UNIVERSITY DEVELOPMENT FUND (contd)

Establishment of Named Endowed Funds (contd)

The Lawrence J. Mervis, M.D. Endowed Fund in Neurosurgery (contd)

It is the desire of the donors that this fund should benefit the University in perpetuity. If the need for this fund should cease to exist or so diminish as to provide unused income, then another use shall be designated by the Board of Trustees in consultation with the senior vice president for Health Sciences and dean of the College of Medicine and Public Health and the director/chairperson of the Division/Department of Neurosurgery, or program administrative officer in order to carry out the desire of the donors.

\$70,000.00

Change in Description of Named Endowed Fund

The Raymond D. Hammond Chemical Engineering Scholarship Fund

The Raymond D. Hammond Chemical Engineering Scholarship Fund was established February 4, 1994, by the Board of Trustees of The Ohio State University with gifts from Raymond D. Hammond (B.Ch.E., 1949). The description was revised December 6, 2002, by the Board of Trustees at the request of Mr. Hammond, the chairperson of the Department of Chemical Engineering, and the dean of the College of Engineering.

All gifts are to be invested in the University's Permanent Endowment Fund, under the rules and regulations adopted by the Board of Trustees of The Ohio State University, with the right to invest and reinvest as occasion dictates.

One-half of the annual income will be reinvested into The Raymond D. Hammond Chemical Engineering Scholarship Fund principal. The remaining half will be used for Raymond D. Hammond Scholarship awards at the discretion of the chairperson of the Department of Chemical Engineering until the deaths of both Raymond D. Hammond and Margaret E. Hammond, upon which the designation of the non-reinvested income will shift to awards for financially deserving students who will be enrolling in the Department of Chemical Engineering and who have demonstrated outstanding scholastic achievement and leadership. This change in designation will occur over a five-year period, such that in Year One 40 percent of the income payout will go to the original designation, and 10 percent to the new designation. In Year Two, 30 percent of the current income will go to the original designation and 20 percent to the new, and so on until Year Five, in which the entire non-reinvested income will be allocated to the new designation.

Preference for Raymond D. Hammond Scholarships will be given to graduates of Bellaire High School, and then to graduates of other Belmont County high schools. In the event there are no chemical engineering candidates, then candidates from other departments within the College of Engineering will be considered, provided they meet the above order of preference.

The award recipients shall be named annually and shall receive first preference for renewed awards, provided they maintain a 3.0 GPA during the previous school year and demonstrate sufficient progress towards graduation in an engineering curriculum. Each scholarship will be apportioned during the academic year. Each scholarship will cover up to a typical engineering undergraduate's costs for tuition, books, fees, and supplies.

Raymond D. Hammond Scholars who qualify for need-based aid may apply for additional assistance to help with board costs. These supplemental grants will be limited to any funds not committed to the basic Raymond D. Hammond Scholarships. The scholarship recipients are to be selected by a committee comprised of the following persons: the principal of Bellaire High School; the superintendent of the Belmont County Educational Services Center; the chairperson

REPORT ON UNIVERSITY DEVELOPMENT (contd)

THE OHIO STATE UNIVERSITY DEVELOPMENT FUND (contd)

Change in Description of Named Endowed Fund (contd)

The Raymond D. Hammond Chemical Engineering Scholarship Fund (contd)

of the Department of Chemical Engineering; the dean of the College of Engineering; and a representative from The Ohio State University Foundation; and in consultation with the University Committee on Student Financial Aid. All unused scholarship dollars will be reinvested into the principal.

It is the desire of the donor that this fund should benefit the University in perpetuity. If the need for this fund should cease to exist or so diminish as to provide unused income over a seven-year period, then another use shall be designated by the Board of Trustees in consultation with the appropriate college dean, department chairperson, or program administrative officer in order to carry out the desire of the donor.

THE OHIO STATE UNIVERSITY FOUNDATION

Establishment of Named Designated Professorships

The John C. Elam/Vorys Sater Designated Professorship in Law

The John C. Elam/Vorys Sater Designated Professorship in Law at the Moritz College of Law was established December 6, 2002, in accordance with guidelines established by the Board of Directors of The Ohio State University Foundation, with gifts made by Moritz College of Law alumni employed by Vorys Sater Seymour & Pease.

A sum of \$37,500 per year will be spent over a five-year period which will provide salary and research support of a professorship position at The Michael E. Moritz College of Law. Appointment to the professorship shall be recommended by the dean of the Moritz College of Law and provost, and approved by the Board of Trustees.

The designated professorship may be renewed at the prevailing amount and term at the time of renewal.

(\$37,500 per year for five years)

The Robert J. Nordstrom Designated Professorship in Law

The Robert J. Nordstrom Designated Professorship in Law at the Moritz College of Law was established December 6, 2002, in accordance with guidelines established by the Board of Directors of The Ohio State University Foundation, with gifts made by Moritz College of Law alumni employed by Porter Wright Morris & Arthur.

A sum of \$37,500 per year will be spent over a five-year period which will provide salary and research support of a professorship position at The Michael E. Moritz College of Law. Appointment to the professorship shall be recommended by the dean of the Moritz College of Law and provost, and approved by the Board of Trustees.

The designated professorship may be renewed at the prevailing amount and term at the time of renewal.

(\$37,500 per year for five years)

REPORT ON UNIVERSITY DEVELOPMENT (contd)

THE OHIO STATE UNIVERSITY FOUNDATION (contd)

Establishment of Named Endowed Funds

Gleason Gearing and Power Transmission Research Fund

The Gleason Gearing and Power Transmission Research Fund was established December 6, 2002, in accordance with the guidelines approved by the Board of Directors of The Ohio State University Foundation, with a gift from the Gleason Foundation of Rochester, New York.

All gifts are to be invested by the Foundation, under the rules and regulations adopted by the Foundation's Board of Directors, with the right to invest and reinvest as occasion dictates.

The annual income shall be used for the support of research related to gearing and power transmission in the Department of Mechanical Engineering or its successor, at the discretion of the department chairperson.

It is the desire of the donor that this fund should benefit the University in perpetuity. If the need for this fund should cease to exist or so diminish as to provide unused income, then another use shall be designated by the Foundation Board in consultation with the dean of the College of Engineering and the chairperson of the Department of Mechanical Engineering in order to carry out the desire of the donor.

\$182,097.00

The Eleanor L. Craig Scholarship Fund

The Eleanor L. Craig Scholarship Fund was established December 6, 2002, in accordance with the guidelines approved by the Board of Directors of The Ohio State University Foundation, with gifts from Eleanor L. Craig (B.S.Bus.Adm., 1934).

All gifts are to be invested by the Foundation, under the rules and regulations adopted by the Foundation's Board of Directors, with the right to invest and reinvest as occasion dictates.

The annual income shall be used to fund a scholarship for a student who is an accounting major, who has a 3.5 or better grade point average (GPA), and who demonstrates financial need. Selection shall be made by The Max M. Fisher College of Business Scholarship Committee in consultation with the University Committee on Student Financial Aid, with formal approval by the dean of the Fisher College of Business.

It is the desire of the donor that this fund should benefit the University in perpetuity. If the need for this fund should cease to exist or so diminish as to provide unused income, then another student-oriented educational use shall be designated by the Foundation Board in consultation with the dean of the Fisher College of Business in order to carry out the desire of the donor.

\$173,606.00

The William M. and Darlene Aldrige
Scholarship Fund in the College of Human Ecology

The William M. and Darlene Aldrige Scholarship Fund in the College of Human Ecology was established December 6, 2002, in accordance with the guidelines approved by the Board of Directors of The Ohio State University Foundation, with gifts from the estate of Darlene Aldrige of Hillsboro, Ohio, and in memory of her husband, William M. Aldrige (B.S.Agr., 1961).

REPORT ON UNIVERSITY DEVELOPMENT (contd)

THE OHIO STATE UNIVERSITY FOUNDATION (contd)

Establishment of Named Endowed Funds (contd)

The William M. and Darlene Aldrige
Scholarship Fund in the College of Human Ecology (contd)

All gifts are to be invested by the Foundation, under the rules and regulations adopted by the Foundation's Board of Directors, with the right to invest and reinvest as occasion dictates.

The annual income shall be used to support scholarships for students enrolled in the College of Human Ecology. The student recipients must exhibit high moral standards; be natives of Highland County, Ohio; and be graduates of a high school in Highland County, Ohio. Annual scholarship recipients shall be selected by the college scholarship selection committee in consultation with the University Committee on Student Financial Aid.

In any given year that the endowment income is not fully expended, the unused portion should be reinvested in the endowment principal.

It is the desire of the donor that this fund should benefit the University in perpetuity. If the need for this fund should cease to exist or so diminish as to provide unused income, then another use shall be designated by the Foundation Board in consultation with the appropriate college dean, school director, department chairperson, or program administrative officer, or their successor, in order to carry out the desire of the donor.

\$150,000.00

The Florence B. Andrews Endowment Fund

The Florence B. Andrews Endowment Fund was established December 6, 2002, in accordance with the guidelines approved by the Board of Directors of The Ohio State University Foundation, with gifts from Henry B. Andrews (B.S.Ed., 1966) of Berea, Ohio.

All gifts are to be invested by the Foundation, under the rules and regulations adopted by the Foundation's Board of Directors, with the right to invest and reinvest as occasion dictates.

The annual income shall be used to purchase books and reference materials concerning English and American literature, library science, and computer science for the Main Library and, if needed, to purchase computer components for the Main Library. Unused income is reinvested into the principal.

It is the desire of the donor that this fund should benefit the University in perpetuity. If the need for this fund should cease to exist or so diminish as to provide unused income, then another use shall be designated by the Foundation Board in consultation with the director of University Libraries in order to carry out the desire of the donor.

\$150,000.00

The Victor King Thompson 1934, 1941 and Marianne Randall Thompson 1938
Scholarship Fund in the Knowlton School of Architecture

The Victor King Thompson 1934, 1941 and Marianne Randall Thompson 1938 Scholarship Fund in the Knowlton School of Architecture was established December 6, 2002, in accordance with the guidelines approved by the Board of Directors of The Ohio State University Foundation, with a gift from Victor King Thompson (B.F.A., 1934; B.Arch., 1941) and Marianne Randall Thompson (B.A., 1938) of Portola Valley, California.

REPORT ON UNIVERSITY DEVELOPMENT (contd)

THE OHIO STATE UNIVERSITY FOUNDATION (contd)

Establishment of Named Endowed Funds (contd)

The Victor King Thompson 1934, 1941 and Marianne Randall Thompson 1938
Scholarship Fund in the Knowlton School of Architecture (contd)

All gifts are to be invested by the Foundation, under the rules and regulations adopted by the Foundation's Board of Directors, with the right to invest and reinvest as occasion dictates.

Victor King Thompson has had a life-long dedication to the study of architecture, both as an individual architect and as a professor. Mr. Thompson was the first professor assigned to Stanford University's new Department of Architecture in 1947, and later became the director of the program. He also has deep roots at The Ohio State University and in the Columbus community. His father, King Thompson, began his own real estate company and was responsible for planning and developing the City of Upper Arlington. While attending the University, Victor Thompson met his wife of 62 years, Marianne Randall, granddaughter of William Oxley Thompson, the longest serving president in Ohio State's history. Victor Thompson's influence in the field of architecture will live on through his work, his students, and through the generations of future students who will benefit from this endowment.

The annual income shall be used to support a scholarship for an architecture student who has financial need, strong academic performance, and a talent for design. Scholarships will be awarded in consultation with the University Committee on Student Financial Aid.

It is the desire of the donors that this fund should benefit the University in perpetuity. If the need for this fund should cease to exist or so diminish as to provide unused income, then another use shall be designated by the Foundation Board in consultation with the director of the Austin E. Knowlton School of Architecture in order to carry out the desire of the donors.

\$82,589.00

The Aschenbach Athletic Endowment Fund

The Aschenbach Athletic Endowment Fund was established December 6, 2002, in accordance with the guidelines approved by the Board of Directors of The Ohio State University Foundation, with gifts from Douglas L. Aschenbach (B.S.Bus.Adm., 1981) of Columbus, Ohio.

All gifts are to be invested by the Foundation, under the rules and regulations adopted by the Foundation's Board of Directors, with the right to invest and reinvest as occasion dictates.

The annual income shall be used to supplement the student-athlete grant-in-aid scholarship costs of student athletes who are members of the men's gymnastics team who are pursuing undergraduate degrees at The Ohio State University. Recipients shall be selected by the director of Athletics in consultation with the University Committee on Student Financial Aid.

It is the desire of the donor that this fund should benefit the University in perpetuity. If the need for this fund should cease to exist or so diminish as to provide unused income, then another use shall be designated by the Foundation Board as recommended by the director of Athletics in order to carry out the desire of the donor.

\$75,000.00

REPORT ON UNIVERSITY DEVELOPMENT (contd)

THE OHIO STATE UNIVERSITY FOUNDATION (contd)

Establishment of Named Endowed Funds (contd)

The Aschenbach Diversity Endowment Fund

The Aschenbach Diversity Endowment Fund was established December 6, 2002, in accordance with the guidelines approved by the Board of Directors of The Ohio State University Foundation, with a gift from Douglas L. Aschenbach (B.S.Bus.Adm., 1981) of Columbus, Ohio.

All gifts are to be invested by the Foundation, under the rules and regulations adopted by the Foundation's Board of Directors, with the right to invest and reinvest as occasion dictates.

The annual income shall be used to fund the recruitment initiatives as deemed necessary by the director of The Ohio State University Marching Band. The fund is intended to promote diversity within the membership of the marching band. Special consideration will be given to African-American students and others who, because of their social and educational backgrounds and accomplishments, have the potential to bring new perspectives to the marching band.

It is the desire of the donor that this fund should benefit the University in perpetuity. If the need for this fund should cease to exist or so diminish as to provide unused income, then another use shall be designated by the Foundation Board in consultation with the appropriate college dean, school director, department chairperson, or program administrative officer in order to carry out the desire of the donor.

\$75,000.00

William Edgerton Fillmore Fund for Excellence in Mechanical Engineering

The William Edgerton Fillmore Fund for Excellence in Mechanical Engineering was established December 6, 2002, in accordance with the guidelines approved by the Board of Directors of The Ohio State University Foundation, with gifts from William Edgerton Fillmore (B.M.E., 1936) of San Clemente, California.

All gifts are to be invested by the Foundation, under the rules and regulations adopted by the Foundation's Board of Directors, with the right to invest and reinvest as occasion dictates.

Currently of San Clemente, California, and formerly of Toledo, Ohio, William E. Fillmore was a distinguished design engineer patenting dozens of ideas and products during his 58-year career with Owens-Illinois, Inc. He retired in 1998.

The annual income as well as growth of the fund shall be used to support the financing of construction of the Department of Mechanical Engineering's new building complex to replace Robinson Laboratory during the period of its financing. Upon the completion of the financing of the construction of the Department of Mechanical Engineering's new building complex to replace Robinson Laboratory, the annual income shall be used in perpetuity for the unrestricted support of the activities of the Department of Mechanical Engineering or its successor unit at the discretion of the department chairperson.

It is the desire of the donor that this fund should benefit the University in perpetuity. If the need for this fund should cease to exist or so diminish as to provide unused income, then another use shall be designated by the Foundation Board in consultation with the dean of the College of Engineering and the chairperson of the Department of Mechanical Engineering in order to carry out the desire of the donor.

\$46,764.33

REPORT ON UNIVERSITY DEVELOPMENT (contd)

THE OHIO STATE UNIVERSITY FOUNDATION (contd)

Establishment of Named Endowed Funds (contd)

The Lyle Aloysius John Gassmann Memorial Award Fund in Optometry

The Lyle Aloysius John Gassmann Memorial Award Fund in Optometry was established December 6, 2002, in accordance with the guidelines approved by the Board of Directors of The Ohio State University Foundation, with gifts from family, friends and classmates.

All gifts are to be invested by the Foundation, under the rules and regulations adopted by the Foundation's Board of Directors, with the right to invest and reinvest as occasion dictates.

During his fourth year of study at Ohio State's College of Optometry, Lyle waged a very courageous fight against non-Hodgkin's lymphoma. He passed away on December 4, 2001, following a successful bone marrow transplant. A very organized and well-prepared student, Lyle quickly became a leader in his class. His charisma, friendliness, and his service to others marked his experience at Ohio State. He was genuinely interested in other people and made friends quickly, probably because people wanted to be around his joyful spirit. Lyle's determination and his infectious enthusiasm for life will be remembered fondly, and sadly missed by all who knew him. The Gassmann family wishes to honor his life through this endowment.

The annual income shall be used to provide an award to the graduating optometry student who best exemplifies Lyle's humanitarian characteristics. Recipients will be selected by the dean of the College of Optometry and the college's Student Affairs staff, in consultation with the college faculty and the University Committee on Student Financial Aid. The Gassmanns will receive annual updates on their fund and will be sent biographical information on each Gassmann Award winner.

It is the desire of the donors that this fund should benefit the University in perpetuity. If the need for this fund should cease to exist or so diminish as to provide unused income, then another use shall be designated by the Foundation Board in consultation with the dean of the College of Optometry in order to carry out the desire of the donors.

\$28,701.00

The Mynydd Teg Endowment Fund for Cancer Genetics Research

The Mynydd Teg Endowment Fund for Cancer Genetics Research at the Comprehensive Cancer Center – The Arthur G. James Cancer Hospital and Richard J. Solove Research Institute was established December 6, 2002, in accordance with the guidelines approved by the Board of Directors of The Ohio State University Foundation, with a gift from the Mynydd Teg Family Foundation of Granville, Ohio.

All gifts are to be invested by the Foundation, under the rules and regulations adopted by the Foundation's Board of Directors, with the right to invest and reinvest as occasion dictates.

The annual income shall be used to support cancer genetics research at the Comprehensive Cancer Center – The Arthur G. James Cancer Hospital and Richard J. Solove Research Institute at The Ohio State University as approved by the director of The Arthur G. James Cancer Hospital and Richard J. Solove Research Institute, the director of the Comprehensive Cancer Center, and the senior vice president for Health Sciences and dean of the College of Medicine and Public Health.

REPORT ON UNIVERSITY DEVELOPMENT (contd)

THE OHIO STATE UNIVERSITY FOUNDATION (contd)

Establishment of Named Endowed Funds (contd)

The Mynydd Teg Endowment Fund for Cancer Genetics Research (contd)

It is the desire of the donor that this fund should benefit the University in perpetuity. If the need for this fund should cease to exist or so diminish as to provide unused income, then another use shall be designated by the Foundation Board in consultation with the director of The Arthur G. James Cancer Hospital and Richard J. Solove Research Institute, the director of the Comprehensive Cancer Center, and the senior vice president of Health Sciences and dean of the College of Medicine and Public Health in order to carry out the desire of the donor.

\$25,391.35

The Cooper/Siedentop Scholarship Fund

The Cooper/Siedentop Scholarship Fund was established December 6, 2002, in accordance with the guidelines approved by the Board of Directors of The Ohio State University Foundation, with gifts from an anonymous alumna. The fund was established to honor two College of Education professors, John O. Cooper and Daryl L. Siedentop.

John O. Cooper served as a member of the special education faculty at The Ohio State University from 1970 until his retirement in 2000. His special areas of interest include behavior analysis and precision teaching in teacher education. He received the Alumni Association Distinguished Teaching Award in 1984. He is co-author of a widely-used textbook, *Applied Behavior Analysis*.

Daryl L. Siedentop served as a member of the sport and exercise faculty from 1970 until his retirement in 2001. He served as interim dean of the College of Education from 1998 to 2000. He was recipient of numerous awards, from OSU, AAHPERD, AERA, and Indiana University. He is author of a widely-used textbook, *Introduction to Physical Education, Sport, and Fitness*.

All gifts are to be invested by the Foundation, under the rules and regulations adopted by the Foundation's Board of Directors, with the right to invest and reinvest as occasion dictates.

The annual income shall be divided evenly and shall provide dissertation support annually to a graduate student in special education-applied behavior analysis, and a graduate student in physical education-teacher education. Selection of the recipients shall be made by the dean of the College of Education in consultation with the faculty in special education and physical education and the University Committee on Student Financial Aid.

It is the desire of the donor that this fund should benefit the University in perpetuity. If the need for this fund should cease to exist or so diminish as to provide unused income, then another use shall be designated by the Foundation Board in consultation with the dean of the College of Education in order to carry out the desire of the donor.

\$25,193.00

Brett E. Lahman Scholarship Fund for Engineers

The Brett E. Lahman (B.S.I.S.E. 2000) Scholarship Fund for Engineers was established December 6, 2002, in accordance with the guidelines approved by the Board of Directors of The Ohio State University Foundation, with gifts from family and friends.

REPORT ON UNIVERSITY DEVELOPMENT (contd)

THE OHIO STATE UNIVERSITY FOUNDATION (contd)

Establishment of Named Endowed Funds (contd)

Brett E. Lahman Scholarship Fund for Engineers (contd)

All gifts are to be invested by the Foundation, under the rules and regulations adopted by the Foundation's Board of Directors, with the right to invest and reinvest as occasion dictates.

The annual income shall be used to award an annual scholarship(s) to a third-year engineering student(s) with preference to a student(s) who exemplifies leadership skills and is active in an engineering student or professional organization, intramural sport, and/or extracurricular activities on campus. In order to be eligible for the scholarship, the student(s) must have a 2.5 to a 3.5 GPA. The student(s) must also have financial need with preference given to a student(s) who is currently working a part-time job and/or a work study position. Scholarships will be awarded in consultation with the University Committee on Student Financial Aid.

In any given year that the endowment income is not fully expended, the unused portion should be reinvested in the endowment principal.

It is the desire of the donors that this fund should benefit the University in perpetuity. If the need for this fund should cease to exist or so diminish as to provide unused income, then another use shall be designated by the Foundation Board in consultation with the family and dean of the College of Engineering in order to carry out the desire of the donors.

\$25,153.13

The Maurice "Mo" Mullet MD Medical Student/Alumni Forum Fund

The Maurice "Mo" Mullet MD Medical Student/Alumni Forum Fund was established December 6, 2002, in accordance with the guidelines approved by the Board of Directors of The Ohio State University Foundation with gifts from Maurice E. Mullet (M.D., 1963) of Berlin, Ohio.

All gifts are to be invested by the Foundation, under the rules and regulations adopted by the Foundation Board of Directors with the right to invest and reinvest as occasion dictates.

The annual income shall be used to support an education forum involving medical students and medical alumni in the College of Medicine and Public Health. This forum is designed to allow for more meaningful dialogue between current medical students and alumni. The Maurice Mullet MD Medical Student/Alumni Forum will be held twice annually and hosted by the OSU Medical Alumni Society and the OSU Medical Student Alumni Council. The topic of each forum and its alumni participants will be identified through a process implemented by the Society and the Council that involves strong participation by the medical students. At least one forum per year shall be focused on issues relating to community health or public health. Allocation of funds shall be approved by the senior vice president for Health Sciences and dean of the College of Medicine and Public Health in consultation with the leadership of the Society (or its designee) and of the Council (or its designee). Funds may support, but are not limited to: associated travel expenses, honorarium, reception, publication costs, etc.

It is the desire of the donor that this fund should benefit the University in perpetuity. If the need for this fund should cease to exist or so diminish as to provide unused income, then another use shall be designated by the Foundation Board in consultation with the senior vice president for Health Sciences and dean of the College of Medicine and Public Health in order to carry out the desire of the donor.

\$25,034.00

REPORT ON UNIVERSITY DEVELOPMENT (contd)

THE OHIO STATE UNIVERSITY FOUNDATION (contd)

Establishment of Named Endowed Funds (contd)

The Joseph A. Alutto MBA Scholarship Fund

The Joseph A. Alutto MBA Scholarship Fund was established December 6, 2002, in accordance with the guidelines approved by the Board of Directors of The Ohio State University Foundation, with gifts from Joseph A. Alutto of Columbus, Ohio.

All gifts are to be invested by the Foundation, under the rules and regulations adopted by the Foundation's Board of Directors, with the right to invest and reinvest as occasion dictates.

The annual income shall be used by The Max M. Fisher College of Business to provide a scholarship(s) to MBA students. Selection of the recipient(s) will be made by a college committee led by the academic director of the MBA Program in consultation with the University Committee on Student Financial Aid with formal approval by the dean of the Fisher College of Business.

It is the desire of the donor that this fund should benefit the University in perpetuity. If the need for this fund should cease to exist or so diminish as to provide unused income, then another use shall be designated by the Foundation Board in consultation with the dean of The Max M. Fisher College of Business in order to carry out the desire of the donor.

\$25,000.00

The Carl Kipp Jr. Paygro/Garick Endowed Scholarship Fund

The Carl Kipp Jr. Paygro/Garick Endowed Scholarship Fund was established December 6, 2002, in accordance with the guidelines approved by the Board of Directors of The Ohio State University Foundation with gifts from Paygro/Garick to honor Carl Kipp, Jr. (B.S.Agr., 1953) of South Charleston, Ohio.

All gifts are to be invested by the Foundation under the rules and regulations adopted by the Foundation's Board of Directors, with the right to invest and reinvest as occasion dictates.

The annual income shall be used to provide scholarship(s) for junior- or senior-year students who are enrolled in the Department of Food, Agricultural, and Biological Engineering, with priority based on a concentration of study in bioenvironmental, soil and water, ecological, or biological engineering. Preference shall be given to students willing to intern at Paygro or Garick. Students shall have a minimum GPA of 3.0 and take a course that includes business or economics-related fundamentals. The selection will be made in consultation with the University Committee on Student Financial Aid.

It is the desire of the donors that this fund should benefit the University in perpetuity. If the need for this fund should cease to exist or so diminish as to provide unused income, then another use shall be designated by the Foundation Board, in consultation with the vice president for Agricultural Administration and University Outreach, and executive dean for Food, Agricultural, and Environmental Sciences, and the chairperson of the Department of Food, Agricultural, and Biological Engineering, or their successors in order to carry out the desire of the donors.

\$25,000.00

REPORT ON UNIVERSITY DEVELOPMENT (contd)

THE OHIO STATE UNIVERSITY FOUNDATION (contd)

Establishment of Named Endowed Funds (contd)

The Kourie Family Athletic Scholarship Fund Honoring Ryan Shockley

The Kourie Family Athletic Scholarship Fund Honoring Ryan Shockley was established December 6, 2002, in accordance with the guidelines approved by the Board of Directors of The Ohio State University Foundation, with gifts from Michael J. (B.A., 1974) and Kathryn M. (B.S.Pharm., 1977) Kourie of San Juan Capistrano, California.

All gifts are to be invested by the Foundation, under the rules and regulations adopted by the Foundation's Board of Directors, with the right to invest and reinvest as occasion dictates.

The annual income shall be used to provide scholarship costs of student athletes who are pursuing undergraduate degrees at The Ohio State University and participating on the varsity football team. Recipients shall be selected by the director of Athletics in consultation with the University Committee on Student Financial Aid and in accordance with NCAA rules.

It is the desire of the donors that this fund should benefit the University in perpetuity. If the need for this fund should cease to exist or so diminish as to provide unused income, then another use shall be designated by the Foundation Board as recommended by the director of Athletics in order to carry out the desire of the donors.

\$25,000.00

Change in Name of Named Endowed Funds

The Chadwick Arboretum Guest Lecturer Endowment Fund

The Seubert Family Chadwick Arboretum Guest Lecturer Endowment Fund was established September 6, 2002, by the Board of Trustees of The Ohio State University with gifts from Howard P. Seubert, (matching gift from Rockwell International), and Mariruth Dresbach Seubert, (M.A., 1958) an avid gardener, and wife of Howard, who participated in the first Franklin County Master Gardener Class in 1993 and has been a longtime supporter and volunteer of the Chadwick Arboretum. Gifts were also given by Suzanne Seubert-Rowan (J.D., 1981), Stuart H. Seubert, and Steven M. Seubert, children of Howard and Mariruth. The name was revised December 6, 2002.

All gifts are to be invested in the University's Permanent Endowment Fund, under the rules and regulations adopted by the Board of Trustees of The Ohio State University, with the right to invest and reinvest as occasion dictates.

The preferred use of the annual income shall be to support a guest lecturer at the Chadwick Arboretum. Other uses could include the sponsorship of educational programs with a focus on public horticultural education. In addition, the income can also be used for any other programs deemed desirable in connection with the operation of the Chadwick Arboretum in the Department of Horticulture and Crop Science in the College of Food, Agricultural, and Environmental Sciences at The Ohio State University.

It is the desire of the donors that this fund should benefit the University in perpetuity. If the need for this fund should cease to exist or so diminish as to provide unused income, then another use shall be designated by the Board of Trustees in consultation with the vice president for Agricultural Administration and University Outreach, and executive dean for Food, Agricultural and Environmental Sciences, and the chairperson of the Department of Horticulture and Crop Science, or their successor, in order to carry out the desire of the donors.

REPORT ON UNIVERSITY DEVELOPMENT (contd)

THE OHIO STATE UNIVERSITY FOUNDATION (contd)

Change in Name of Named Endowed Funds (contd)

The Mary E. Babcock Unrestricted Endowment Fund

The Mary E. Babcock Endowment Fund was established May 7, 1999, in accordance with the guidelines approved by the Board of Directors of The Ohio State University Foundation, with unrestricted gifts to The Ohio State University Foundation from the estate of Mary Elizabeth Babcock. The name was revised December 6, 2002.

All gifts are to be invested by the Foundation, under the rules and regulations adopted by the Foundation Board of Directors, with the right to invest and reinvest as occasion dictates.

The annual income shall be used at the discretion of the president of The Ohio State University for the purpose of providing resources for fund raising at the University.

It is the desire of the Foundation that this fund should benefit the University in perpetuity. If the need for this fund should cease to exist or so diminish as to provide unused income, then another use shall be designated by the Foundation Board of Directors.

EMPLOYMENT OF ARCHITECTS/ENGINEERS

Resolution No. 2003-72

DOAN HALL 11 – INFECTIOUS DISEASES
BIOLOGICAL SCIENCES BUILDING – ROOMS 517, 517A AND 521

Synopsis: Authorization to employ architectural/engineering firms for the Doan Hall 11 - Infectious Diseases and Biological Sciences Building – Rooms 517, 517A, and 521 projects is requested.

WHEREAS Health Sciences desires to renovate space on the 11th floor of Doan Hall to consolidate Infectious Diseases office space, including space for the new department chair; and

WHEREAS the preliminary project cost estimate is approximately \$412,000 with design costs being funded by Health Sciences; and

WHEREAS the College of Biological Sciences desires to renovate rooms 517, 517A, and 521 of the Biological Sciences Building to meet current standards for a biosafety level 3 containment facility; and

WHEREAS the preliminary project cost estimate is approximately \$298,000 with design costs being funded by the College of Biological Sciences:

NOW THEREFORE

BE IT RESOLVED, That the President and/or Senior Vice President for Business and Finance be authorized to contract with qualified architectural/engineering firms as necessary for the Doan Hall 11 - Infectious Diseases and Biological Sciences Building – Rooms 517, 517A, and 521 projects and that the fees for these services be negotiated between the firms selected and the University.

(See Appendix XXIX for background information and maps, page 643.)

AMENDMENT OF ALTERNATIVE RETIREMENT PLAN

Resolution No. 2003-73

Synopsis: Authorization to amend the University's Alternative Retirement Plan to conform to requirements of the Internal Revenue Code is proposed.

WHEREAS the Board of Trustees adopted The Ohio State University Alternative Retirement Plan ("the Plan"), effective February 5, 1999; and

WHEREAS the University reserved the right in Section 8.3 of the Plan to amend the Plan by action of the Board of Trustees; and

WHEREAS The Economic Growth and Tax Relief Reconciliation Act of 2001 requires certain amendment be made to the Plan; and

WHEREAS the Board desires to approve a formal amendment to the Plan in order to comply with Internal Revenue Code requirements:

NOW THEREFORE

BE IT RESOLVED, That an Amendment to the Plan, a copy of which is on file with the Office of the Board of Trustees, is hereby adopted effective January 1, 2002; and

BE IT FURTHER RESOLVED, That the Senior Vice President for Business and Finance, in consultation with the Office of Human Resources and the Office of Legal Affairs, is hereby authorized to execute the Plan Amendment and any other instruments, documents, or conveyances necessary to effectuate the Amendment, to submit the Plan to the Internal Revenue Service; and

BE IT FURTHER RESOLVED, That the Senior Vice President for Business and Finance, in consultation with the Office of Human Resources and the Office of Legal Affairs, in carrying out this resolution, is hereby authorized and empowered to make any necessary changes to the Plan as may be required to ensure compliance with the provisions of the Internal Revenue Code of 1986 and the Ohio Revised Code, and any related rules and regulations, currently in effect or as hereinafter amended, and to take such further action as may be necessary or advisable to implement this resolution without further ratification or action by this Board.

(See Appendix XXX for background information, page 647.)

ESTABLISHMENT OF A NEW SELF-INSURANCE TRUST

Resolution No. 2003-74

Synopsis: Establishment of a new Self-Insurance Trust is proposed.

WHEREAS on November 1, 2002, the University Board of Trustees adopted a Medical Practice Plan establishing a college central practice group; and

WHEREAS the senior vice president for Health Sciences and dean of the College of Medicine and Public Health has approved and designated Ohio State University Physicians (OSUP) as the college central practice group pursuant to the Medical Practice Plan; and

WHEREAS each faculty member who provides patient care and is employed by a clinical department of the College of Medicine and Public Health (COMP) will be an employee of OSUP; and

ESTABLISHMENT OF A NEW SELF-INSURANCE TRUST (contd)

WHEREAS the practice of medicine constitutes an integral part of faculty appointments in clinical departments of the College of Medicine and Public Health and thus an integral part of the University mission of patient care, service, research, and teaching; and

WHEREAS the University established a self-insurance trust in 1976 to meet claims brought against the Hospital and Oval Ltd., a captive insurance company in 1994, and formed a self-insurance committee to oversee that self-insurance program; and

WHEREAS section 3345.202 of the Ohio Revised Code permits the Board of Trustees of a state university to establish insurance programs for officers and employees of the university and others authorized by the Board; and

WHEREAS the provision of reliable and affordable medical malpractice/liability insurance through the University self-insurance program supports the achievement of excellent patient care, service, research, and teaching and the University's ability to recruit and retain qualified faculty members; and

WHEREAS the leadership of the Medical Center and the self-insurance committee have recommended that the self-insurance program be expanded to provide medical malpractice/liability insurance for faculty members and staff who are involved in the delivery of clinical care and are employed by OSUP, the OSU Health System, or the College of Medicine and Public Health:

NOW THEREFORE

BE IT RESOLVED, That the University Board of Trustees shall cause to be established a new self-insurance trust to provide medical malpractice/liability coverage for faculty and staff who are involved in the delivery of clinical care and employed by OSUP, the OSU Health System, or the College of Medicine and Public Health in accordance with the following initial minimum requirements:

1. This self-insurance program shall be administered by a Self-Insurance Board, to be appointed by the University Board of Trustees, based upon the recommendations of the President, and will operate under the guidelines established by The Ohio State University Board. The majority of the Board should be composed of citizen independent members.
2. The Self-Insurance Board shall determine the level of medical malpractice insurance coverage for eligible participants and shall have the authority to establish differential premiums and/or deductibles and to exclude individuals from coverage.
3. OSUP, as the college central practice group, shall have the continuing financial responsibility to contribute annually the amount actuarially determined and approved by the Self-Insurance Board to be necessary for that year for primary and excess coverage of such eligible faculty members.
4. Upon approval of the application for coverage submitted by a faculty member, the self-insurance program shall provide coverage for that faculty member while he/she is acting within the approved scope of his/her duties in providing patient care at locations and under conditions as approved by the senior vice president for Health Sciences and dean of the College of Medicine and Public Health.
5. This self-insurance program shall not become effective until an Agreement is executed between the University and OSUP.
6. The current self-insurance trust shall continue in operation and be administered by the newly appointed Self-Insurance Board.

ESTABLISHMENT OF A NEW SELF-INSURANCE TRUST (contd)

7. A strict system to provide checks and balances should be established for managing the physician's liability including malpractice claim exposure and the clinical risks including a particular specialty.
8. The Board of Trustees through the appropriate University governance structure should be kept current on all critical issues concerning the Self-Insurance program. That should include, but not be limited to, reporting regularly to the Fiscal Affairs (Audit) Committee of The Ohio State University Board of Trustees.

Upon motion of Mr. Borrer, seconded by Ms. Hendricks, the Board of Trustees adopted the foregoing resolutions by unanimous roll call vote, cast by Messrs. Patterson, Sofia, Slane, McFerson, Borrer, and Judge Duncan, Mses. Hendricks and Davidson.

Mr. Patterson:

It bears noting in terms of the establishment of the Self-Insurance Trust that while all issues that come before the Board have some great importance, this issue to a large degree was Step Two in a long process of the changes that are going on at our academic medical center. The Self-Insurance Trust is an issue of extreme complexity that the University has been involved in and takes on a huge importance as we make these changes.

I want to thank all who participated: Dean Sanfilippo, Kate Haller, Reed Fraley, and Dr. Ellis; members of the Board, particularly Vice Chairman Sofia, Dan Slane, Dimon McFerson, and Bob Duncan; and to Ginny Trethewey for her help in the legal aspects of this. This was a very complex issue to walk through and a tremendous amount of hours have been spent on it. It's a very positive step for the University and keeps us in that "go-forward" position.

--0--

ANNUAL AUDIT AND FINANCIAL REPORT

Mr. William J. Shkurti:

We will be asking for your approval on the audit and financial report for the year ending June 30, 2002. This is Item 13 on your Board agenda and has been previously reviewed in detail by the Fiscal Affairs Committee, so I will just summarize the highlights.

First, I'd like to introduce a couple of the key participants in this process: Mike Fritz, managing partner for Deloitte and Touche; Kevin Patton, director of Internal Audit; and Greta Russell, University Controller, and her staff. Greta is not here this morning, because I've given her too much other work to do today.

I think the two most important things that I can say in summary about the audit is first of all, it's a clean audit, which is something we always strive to achieve. Secondly, this particular audit represents a successful transition to a new reporting system that includes maintaining the traditional fund accounting for control purposes as a public entity. It also involves a more business-type of reporting for purposes of aggregating our financial statements.

One of the new items related to this new reporting format is a 13-page management discussion and analysis summary, which is the first time this has been done for the University. There are two major points that are in that document that I would just like to summarize. One is that the University is financially sound, despite a rather challenging fiscal environment. And secondly, the University is continuing to become less dependent on state support, and

ANNUAL AUDIT AND FINANCIAL REPORT (contd)

Mr. Shkurti: (contd)

more dependent on other sources of revenue. A good example is the sponsored research that Brad Moore talked about earlier.

There are two implications from this shift, and this has been a shift that has been going on for a number of years. First of all, as the University becomes more entrepreneurial, it means we also need to manage the risk associated with those entrepreneurial efforts. Secondly, it also means because these entrepreneurial funding sources aren't guaranteed -- although state funding is not guaranteed either as we have found out -- we need to be better able to redirect our resources here at the University. This is discussed in greater detail in the management letter that I mentioned, but I thought they were important to be highlighted.

In conclusion, I would say that the University is well positioned to advance in achieving its academic goals despite an uncertain fiscal environment, but that we will continue to need to adapt and continuously improve our management of financial resources. That concludes my presentation, Mr. Chairman. If there are any questions, I'll be glad to respond.

ACCEPTANCE OF THE REPORT OF AUDIT FOR 2001-02

Resolution No. 2003-75

Synopsis: The report of the audit of the financial statements for The Ohio State University for 2001-02 conducted by Deloitte & Touche is recommended for acceptance.

WHEREAS with the approval of the Auditor of State, The Ohio State University entered into a four-year agreement with Deloitte & Touche in March 2002 for an annual audit of the University for fiscal years 2001-02 through 2004-05; and

WHEREAS the Deloitte & Touche audit of the University for 2001-02, meeting the requirements of the Auditor of State, has been received and the accounts, records, files, and reports of the University have been found to be in satisfactory condition, and certain internal control recommendations have been discussed with the Fiscal Affairs Committee; and

WHEREAS the auditors' internal control recommendations are being reviewed by the appropriate University offices, and appropriate procedures and responses are being developed as a result of these recommendations:

NOW THEREFORE

BE IT RESOLVED, That the report of the Deloitte & Touche audit for The Ohio State University for 2001-02, including the report on the audit of the University's financial statements and the summary of significant internal control recommendations to management, be accepted.

Upon motion of Mr. Sofia, seconded by Ms. Hendricks, the Board of Trustees adopted the foregoing resolution by unanimous roll call vote, cast by Messrs. Patterson, Sofia, Slane, McFerson, Borrer, and Judge Duncan, Mses. Hendricks, and Davidson.

--0--

Mr. Patterson:

That brings us to the end of the agenda. I think it's worth noting that within the things that we've done today, there has been a couple of very important actions that have been worked on for a long period of time. There was the President's

December 6, 2002 meeting, Board of Trustees

Mr. Patterson: (contd)

positive report on some of the actions that we're taking in regard to some of the events that have occurred in our past, recognition of the huge effort and great strides that research is making at the University, and the recognition of an outstanding student.

This University has been hung up on the number 13 since the football team played Michigan. Brad referred to it, Bill referred to it. That magic number for Ohio State is going to change to 14 in about three weeks, on January 3.

Happy holidays to all of you.

--0--

Thereupon the Board adjourned to meet Friday, February 7, 2003, at The Ohio State University Davis Heart and Lung Institute, Columbus, Ohio.

Attest:

Maureen T. Sharkey
Associate Secretary

James F. Patterson
Chairman



Requesting Agency(s): HEALTH SCIENCES ADMINISTRATION

Location(s): DOAN HALL, CHARLES AUSTIN **Gross Sq. Ft.** 669,869 **Age:** 1951

Description: Renovation of 11th floor of Doan Hall to consolidate Infectious Diseases office space, including space for the new Office Chair.

<p>Project Team:</p> <p>Facility Planner: Is Unassigned</p> <p>Project Captain: Richard Van Deusen (van-deusen.2@osu.edu)</p> <p>Project Assistant: Karen Cogley (cogley.1@osu.edu)</p> <p>Field Coordinator: Is Unassigned</p>	<p>Project Information:</p> <p>Formerly known as 50700-R025184. Preliminary project budget of \$412,000.</p>
--	---

Source of Funds:	Original	Revised	Uses of Funds:	As Designed	As Bid	Completion

Schedule:	Projected	Revised	Actual
Planning			
Arch/Engr Approved by B/T	12/06/2002		

Doan Hall II - Infectious Diseases

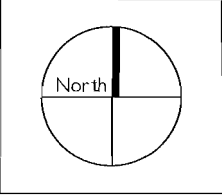
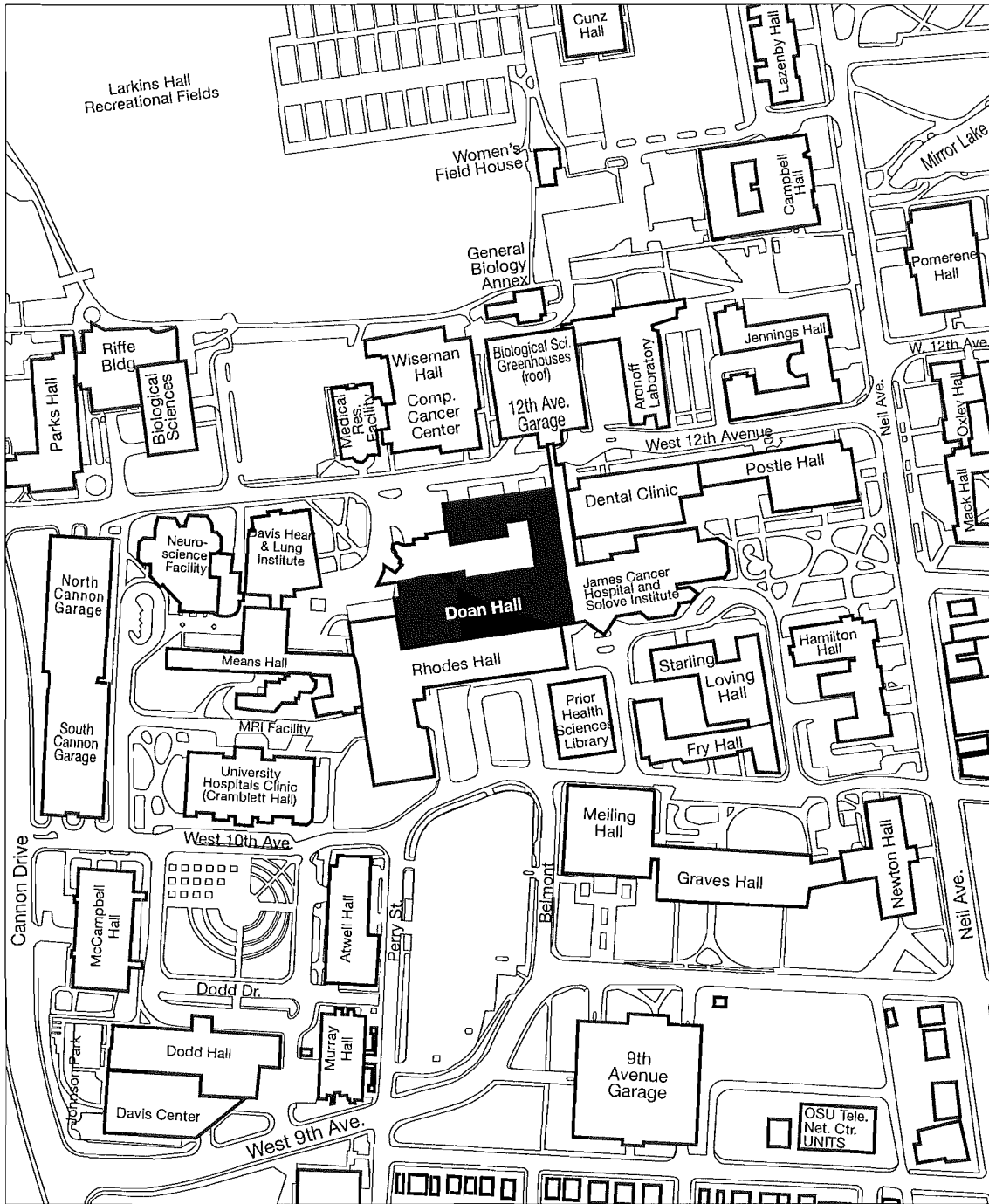

Office of Business and Finance
Office of Facilities Planning and Development

November 14, 2002



Requesting Agency(s): BIOLOGICAL SCIENCES ADMINISTRATION

Location(s): BIOLOGICAL SCIENCES BUILDING

Gross Sq. Ft. 182,129 Age: 1970

Description: Renovate rooms to meet current standards for a Bio Safety Level 3 facility. This includes a drop ceiling with out-of-room access to above-ceiling spaces for maintenance personnel; recessed lighting with weatherproof gaskets; weather-tight, self closing doors; an enlarged anteroom with key-card access and interlocking doors; campus phones; video surveillance system and ventilation system adjustments to maintain negative pressure in rooms.

Project Team:

Facility Planner: Is Unassigned

Project Captain: Steve Middleton
(middleton.52@osu.edu)

Project Assistant: Is Unassigned

Field Coordinator: Is Unassigned

Project Information:

Preliminary project budget of \$300,000.

Source of Funds:	Original	Revised

Uses of Funds:	As Designed	As Bid	Completion

Schedule:	Projected	Revised	Actual
Planning			
Arch/Engr Approved by B/T	12/06/2002		

Biological Sciences Building - Rooms 517, 517A and 521

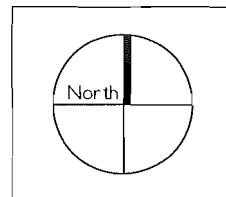

Office of Business and Finance
Office of Facilities Planning and Development

November 14, 2002

AMENDMENT OF THE OHIO STATE UNIVERSITY ALTERNATIVE RETIREMENT PLAN FOR
THE ECONOMIC GROWTH AND TAX RELIEF RECONCILIATION ACT OF 2001

PREAMBLE

This amendment of the Ohio State University Alternative Retirement Plan (the "Plan") is adopted to reflect certain provisions of the Economic Growth and Tax Relief Reconciliation Act of 2001 ("EGTRRA"). This amendment is intended as good faith compliance with the requirements of EGTRRA and is to be construed in accordance with EGTRRA and guidance issued thereunder. Except as otherwise provided, this amendment shall be effective as of the first day of the first Plan Year beginning after December 31, 2001.

This amendment shall supersede the provisions of the Plan to the extent those provisions are inconsistent with the provisions of this amendment.

1. Section 2.6 of the Plan is amended by the addition of the paragraph below to the end of Section 2.6:

"The annual Compensation of each Participant taken into account in determining allocations for any Plan Year beginning after December 31, 2001, shall not exceed \$200,000, as adjusted for cost-of-living increases in accordance with Section 401(a)(17)(B) of the Code. Annual Compensation means Compensation during the Plan Year or such other consecutive 12-month period over which Compensation is otherwise determined under the Plan (the determination period). The cost-of-living adjustment in effect for a calendar year applies to annual Compensation for the determination period that begins with or within such calendar year."

2. Section 5.3 is amended by the addition of the below paragraphs to the end of Section 5.3(d)(vi).

(vii) "The preceding paragraph in this Section 5.3(d)(vi) is effective for Limitation Years beginning before December 31, 2001. Effective for Limitation Years beginning after December 31, 2001, except to the extent permitted under Section 414(v) of the Code (if applicable), the annual addition that may be contributed or allocated to a Participant's Account under the Plan for any Limitation Year shall not exceed the lesser of:

- (a) \$40,000, as adjusted for increases in the cost-of-living under Section 415(d) of the Code, or
- (b) 100 percent of the Participant's compensation, within the meaning of Section 415(c)(3) of the Code, for the Limitation Year.

The foregoing limit is referred to as the "415(c) Limit." The 415(c) Limit with respect to any Participant for a Limitation Year, plus the amount of any additional elective deferral permitted to be made by a Participant under Section 414(v) of the Code with respect to such Limitation Year, is referred to as the "Maximum Permissible Amount." The compensation limit referred to in (b)

shall not apply to any contribution for medical benefits after separation from service (within the meaning of Section 401(h) or Section 419A(f)(2) of the Code) which is otherwise treated as an annual addition.”

If there is a short Limitation Year because of a change in the Limitation Year, the administrator will multiply the \$40,000 limitation (or larger limitation) by the following fraction: number of months in the short Limitation Year divided by twelve (12).”

3. Sections 7.6 and 7.9 are amended by the addition of the following paragraphs to the end of each Section:

“ Effective date. This Section shall apply to distributions made after December 31, 2001.

Modification of definition of Eligible Retirement Plan. For purposes of the direct rollover provisions in these Sections 7.6 and 7.9, an Eligible Retirement Plan shall also mean an annuity contract described in Section 403(b) of the Code and an eligible Plan under Section 457(b) of the Code which is maintained by a state, political subdivision of a state, or any agency or instrumentality of a state or political subdivision of a state and which agrees to separately account for amounts transferred into such plan from this Plan. The definition of Eligible Retirement Plan shall also apply in the case of a distribution to a surviving Spouse, or to a Spouse or former Spouse who is the alternate payee under a Qualified Domestic Relation Order, as defined in Section 414(p) of the Code.

4. Section 7.9 is further amended as provided below by the addition of the following to the end of Section 7.9:

“In addition to, and subject to, the foregoing terms and conditions (with the exception of those provisions regarding the acceptance of rollover contributions from conduit individual retirement accounts), effective January 1, 2002, the Plan will accept Participant rollover contributions and/or direct rollovers of distributions made after December 31, 2001, from the types of plans specified below.

Direct Rollovers:

The Plan will accept a direct rollover of an Eligible Rollover Distribution from:

X a qualified plan described in Section 401(a) or 403(a) of the Code.

X an annuity contract described in Section 403(b) of the Code.

X an eligible plan under Section 457(b) of the Code which is maintained by a state, political subdivision of a state, or any

agency or instrumentality of a state or political subdivision of a state.

Participant Rollover Contributions from Other Plans:

The Plan will accept a Participant contribution of an Eligible Rollover Distribution from:

X a qualified plan described in Section 401(a) or 403(a) of the Code.

X an annuity contract described in Section 403(b) of the Code.

X an eligible Plan under Section 457(b) of the Code which is maintained by a state, political subdivision of a state, or any agency or instrumentality of a state or political subdivision of a state.

Participant Rollover Contributions from IRAs:

The Plan will accept a Participant rollover contribution of the portion of a distribution from an individual retirement account or annuity described in Section 408(a) or 408(b) of the Code that is eligible to be rolled over and would otherwise be includible in gross income.

Notwithstanding any of the foregoing, the Plan will not accept any portion of a rollover contribution or a direct rollover that includes after-tax employee contributions.

5. Section 7.9 is amended in its entirety for distributions made after December 31, 2001 as set forth below:

“The amount transferred to the Plan must be transferred within sixty (60) days of the date such individual received the Eligible Rollover Distribution, provided, however, that for distributions made after December 31, 2001, the Secretary of the Treasury may waive the 60-day rollover period if the failure to waive such requirement would be against equity or good conscience, including cases of casualty, disaster, or other events beyond the reasonable control of the individual as provided under Code Sections 402(c)(3) and 408(d)(3).”

IN WITNESS WHEREOF, the University hereby adopts this Amendment to The Ohio State University Alternative Retirement Plan, effective as of January 1, 2002, except as otherwise noted herein, this 6th day of December 2002.

THE OHIO STATE UNIVERSITY
OFFICIAL PROCEEDINGS OF THE
ONE THOUSAND THREE HUNDRED AND NINETIETH MEETING
OF THE BOARD OF TRUSTEES

Columbus, Ohio, February 7, 2003

The Board of Trustees met at its regular monthly meeting on Friday, February 7, 2003, at The Ohio State University Davis Heart and Lung Institute, Columbus, Ohio, pursuant to adjournment.

**

**

**

Minutes of the last meeting were approved.

**

**

**

February 7, 2003 meeting, Board of Trustees

The Chairman, Mr. Patterson, called the meeting of the Board of Trustees to order on February 7, 2003, at 10:40 a.m. He requested the Secretary to call the roll.

Present: James F. Patterson, Chairman, Zuheir Sofia, Tami Longaberger, Daniel M. Slane, Robert M. Duncan, Karen L. Hendricks, Dimon R. McFerson, Jo Ann Davidson, Douglas G. Borrer, Joseph A. Shultz, and Paula A. Habib.

--0--

PRESIDENT'S REPORT

President Karen A. Holbrook:

Good morning. As I think all of you know, I typically focus my remarks on something that is of immediacy to this University or is particularly relevant to events locally or nationally that impact on our University. I'm going to do the same thing this morning, only I've chosen to discuss two items this time: one that's of local and national importance and one that's of particularly local importance.

The first topic is diversity. This is on my mind for a number of reasons. The tragic loss of the Columbia last weekend focused the nation's attention on seven individuals who served as its crew. These individuals were a team that worked together in the exploration of space and the advancement of science with a passionate belief that what we could learn from space flight would benefit mankind.

The team was composed of men and women of different nationalities, races, and disciplines. The diversity of this team was readily apparent and brought clearly to mind the connection between excellence and diversity. I readily appreciate that diversity -- like the diversity demonstrated by the Columbia crew -- includes differences in people other than race. For example, it includes: socioeconomic, geographic origin, intellectual, gender, religious, sexual orientation, and physical status.

However, racial diversity is in the forefront right now as we celebrate Black History Month across the nation, the 30th United Black World Month at Ohio State, and as we anticipate a future landmark decision from the United States Supreme Court on the two admissions cases before them from the University of Michigan. This will be the first ruling of the Supreme Court in two decades regarding race-conscious admissions decisions. In 1978, the Supreme Court ruled in the Bakke vs. California case that race and ethnicity may be considered among factors aimed at assuring diversity in admissions as a compelling interest.

The two Michigan cases are of enormous national importance. They provide an historic opportunity to shape the future of higher education in our country and their outcome will affect all colleges and universities. What is at stake? Is it the very quality of our universities and our ability to prepare students to live and work in our diverse democracy and in the global economy?

Diversity is of value for Ohio State. Achieving diversity among our population of students, faculty, and staff is a goal. It's about fairness and justice to provide access to education for all citizens, essential to prepare life in the working world, for good citizenship, and for political leadership.

With the changing demographics, our students must be effective and comfortable in their interactions with people who may not think in the same way they do. Employers expect students to work and interact with an increasingly wider group of people, to see the world as a community of interdependent people.

PRESIDENT'S REPORT (contd)

President Holbrook: (contd)

Knowledge, understanding, and acceptance of other people and cultures are essential.

There is a fundamental link between diversity and the educational mission. Diversity is an end to itself – a practice of educational value, not a way of remedying discrimination or adjusting racial quotas. Diversity adds to the learning experience, expands classroom examples, improves communication and understanding, and sharing of different life experiences.

Diversity brings to light the fact that there are differences among people of different races and among people of the same race; individuals cannot be stereotyped. Diversity fosters intellectual and social growth, and forces students to change their assumptions and to learn. It simply provides a good learning environment for everyone.

In our institution it is everyone's responsibility to foster a climate of respect, increase and retain individuals with diverse backgrounds, lifestyles, and cultures, to expand multicultural education, and to communicate our goals and our educational value of diversity.

Ohio State has a background of strong support for diversity and our campus today is more ethnically and racially diverse than at any time in its history. At the same time, the academic quality and performance of our student body are at the highest level ever.

Many of the students and faculty want to know the position of Ohio State University in this situation, and thus I want to reaffirm and to state unequivocally that The Ohio State University is committed to promoting and supporting diversity for our community. To that end, I'd like to be clear about Ohio State's position with regard to the Michigan cases.

The University has filed two amicus briefs when the cases were heard in the 6th Circuit Court. A few weeks ago, I sent a letter to President Bush in support of the Michigan case, reaffirming our belief that the Bakke case remains and should remain the law of the land. Thirty-four national associations of colleges and universities, both public and private, have also joined forces to advocate on behalf of the University of Michigan, to urge the president, and thus the Supreme Court to reaffirm the 1978 decision.

I sent an op-ed piece to *The Lantern* on our position. Professor Deborah Merritt and her colleague, Bill Lann Lee, former assistant attorney general for civil rights, expressed their views in an op-ed that will be published in *The Washington Post* in response to President Bush's request that universities consider "life experiences," when admitting students. She posits that race is a life experience. And, Dr. Mac Stewart published an eloquent piece in the *Columbus Post* supporting President Mary Sue Coleman at Michigan in describing the value of the Bakke decision.

Many of our students and faculty have urged Ohio State to send an amicus brief in response to President Bush's brief by the February 18 due date on behalf of Michigan. Michigan's legal staff, however, has requested that institutions instead ask their state attorneys general to sign onto a brief that is being prepared by the National Association of Attorneys General. We are in active consultation with Ohio's attorney general at present as to our position with regard to that brief.

PRESIDENT'S REPORT (contd)

President Holbrook: (contd)

Let me close this section of my report with a quote from William Raspberry, the author of an editorial published in *The Washington Post* last weekend. He explains that how we argue for diversity publicly is reflected in whether we see it as an issue or as a goal. He says that:

“Issues, by their very nature, divide. They force us to choose sides, to work against one another, to produce winners and losers. That is their political purpose.

Goals, on the other hand, can be shared -- even when we embrace different means for reaching them. There is, of course, no *one* way of producing the goal of diversity -- no way, including Michigan's, that is utterly without flaws. But doing nothing is an option only for those who think the goal isn't very important.”

And Ohio State does see diversity as a goal – a very important goal.

Let me turn briefly, then, to the second topic that I'd like to address publicly, and that is the status of our state budget for the University. We're concerned with our current funding, our future allocation, and the impact of the statewide budget on the tuition of all of our current and prospective students, and on our ability to implement our Academic Plan.

The governor has presented his budget and it is now being deliberated by the General Assembly. As you know, the downturn in the state economy did not predict the more than \$720 million shortfall suggested to exist for the remainder of this budget year. The governor's first goal must be to balance the current budget, then to propose a plan for the forthcoming biennial budget.

The good news for higher education is that he has proposed: 1) no budget cuts in education during the remainder of this year, while all other state agencies were cut by 2.5 percent; 2) increases in the state's share of instruction for universities for FY '04 and FY '05 at the level of three percent and four percent respectively; 3) capped tuition – with the cap set at six percent for all state institutions except for Ohio State, which would be capped at nine percent; 4) state schools that are at or below the statewide tuition mean may add a \$300 surcharge to the tuition of incoming students; and 5) the development of a commission on higher education in the economy that was proposed to evaluate increased effectiveness in higher education, to reduce unnecessary duplication, to broaden use of technology, and to determine how higher education can support the state's economy and add to the quality of life.

This is the best possible situation considering the budget climate, even though certain line items in the state budget for Ohio State were deleted. But there are conditions under which our state share of instruction will not be held harmless for the remainder of the year. There must be new revenue sources identified by February 20 that can be put into place by March 1. If this fails, Ohio State will face a \$7.7 million deficit in the current year's budget. This means we will need to return \$7.7 million from the remaining budget for the last few months of this year.

The legislature is currently agonizing over possible remedies. The issue is very complex and short-term solutions may be only a Band-Aid. We support the governor and the legislature in their efforts to protect higher education through revenue enhancements and other means. We will continue working with our

PRESIDENT'S REPORT (contd)

President Holbrook: (contd)

elected officials in making the case for funding the high-quality programs that we offer as the budget process continues, and we will continue to keep the Board apprised of our deliberations.

At the same time we're considering these financial issues in the near term, we're also examining our options for the future. You will hear a thoughtful presentation this morning by Provost Ray and Senior Vice President Shkurti on how we plan to meet our long-term academic goals without relying solely on tuition and state revenue enhancements.

These are only two of the challenges that confront our University. There are other national concerns that could have profound personal and social implications for our country. Ohio State is a family, as we've shown so graphically during the last several weeks as we cheered on and then celebrated our national championship football team.

This camaraderie is going to be ever more important to be sustained as we go forward in times that may not be as favorable as they have been. We will need that mutual support more than ever. Collegiality is much easier in good times, but it's even more essential in times of stress.

I'm certain that we can sustain the great Buckeye spirit of victory, success, and optimism in the months to come as we continue to move forward on our goals in the Academic Plan. Thank you very much.

--0--

PRESENTATION ON BUDGET/LONG-TERM RESOURCE STRATEGIES

Provost Edward J. Ray: [PowerPoint Presentation]

As President Holbrook indicated, we have some very real resource challenges facing us immediately, and positioning ourselves to deal with them and deal with the longer term challenges that we in the State of Ohio face is also important for us to pay attention to. What Bill Shkurti and I would like to do today is talk a little bit about -- both on the revenue and cost side -- what we're doing to position ourselves to move forward with implementation of the Academic Plan in the longer run and to share how we propose to get to a better place.

The issues that we want to talk about are: 1) What have we learned from what we've done to date? What's our historical record been and how does it prepare us for the future? 2) What other revenue opportunities are there? 3) What are some of the real prospects we have going forward? 4) What opportunities are there for cost reductions? and 5) How can we best organize ourselves to achieve our goals of expanding our revenue capabilities and managing our costs more efficiently?

The first thing we want to do is talk about lessons learned. Our own benchmarking shows that our costs are substantially below those of comparable institutions, but that doesn't translate into diminished expectations from our students, from the community, or from the State of Ohio. So we start in a very challenged situation and that means we have to use all of the resources available to us as intelligently as possible.

PRESENTATION ON BUDGET/LONG-TERM RESOURCE STRATEGIES (contd)

Provost Ray: (contd)

On the other hand, OSU's size and diversity give us a comparative advantage to formulate unique sources of additional income and cost reduction. When we talk about one of our strengths in implementing the Academic Plan, we talk about not only our size but also the scope of our academic programs and the opportunities that creates for us to do things that are not possible at most other universities.

Bill will talk about what we can do with respect to cost savings and that we have to be committed for the long haul. If we're going to make substantial efficiencies on the cost side, we can't do it in one easy sweep.

We've made efforts in the past to contract out for services or at least look at those possibilities. We've learned that sometimes contracting out is a blessing and sometimes it becomes a problem in maintaining accountability. So as we go forward, we need to think about where contracting out looks appropriate and where, in fact, we can manage things better through our own practices.

We've learned some hard lessons. Good business practices and good education practices are not inherently in conflict with each other, and we need to make them as mutually supportive and as complementary as possible. Some of the actions we've taken – for example, the changes that we're implementing in the budget process – are intended to show that we can manage resources in a way that's supportive of what we're trying to accomplish through the Academic Plan.

Another point -- and I've heard the president say this on a number of occasions -- is that excellence doesn't come cheap. The president's phrase is that there is no such thing as cheap excellence. We are committed to moving this institution forward and that means that we need to have the resources to get the job done right. But we also understand that resources in and of themselves don't ensure success. We've got to be as focused and effective in our use of those resources as possible.

We have a long record of innovative approaches to developing revenue sources and achieving cost reductions, and let me just mention a couple. We obviously started increased fundraising in the early- to mid-1980s and we all know of the extraordinary success of our second major campaign, the Affirm Thy Friendship Campaign, which brought in \$1.23 billion in a five-year period.

We also learned that charging non-general fund units for their share of support costs would be helpful to the University, so we implemented that in the 1980s. We've developed exclusive beverage and Affinity Card agreements since the early- or mid-1990s. We've done pricing to market or setting tuition where we thought appropriate with respect to our graduate and professional programs, particularly starting in the mid-1990s. We've put in place significant surcharges to non-resident students, a practice that we began in the 1980s.

On the cost side, we have Managed Care and other benefits that were implemented in the 1980s, energy conservation and cost reduction since the 1970s, and the hospital self-insurance for malpractice since the 1970s. In the mid-1990s, we went through a comprehensive restructuring of many academic units and programs.

We want to talk about revenue-raising and cost-cutting efforts that obviously have intensified over the last couple of years. We're not initiating a conversation now about what we could do on the revenue and cost side. This activity has really accelerated in the last two years.

PRESENTATION ON BUDGET/LONG-TERM RESOURCE STRATEGIES (contd)

Provost Ray: (contd)

On the revenue side, we've developed our so-called "Outside the Box" initiative. That included changes in state law for non-endowment investments, new Affinity Card agreements, and the self-funding of development, which we began a year or so ago. We increased extramural sponsorship for research, quite dramatically. You've heard reports on that and we're continuing to see expanding success in that area.

We've increased cost recovery on federally sponsored research, including salary recovery. Senior Vice President Sanfilippo and his colleagues in the health sciences have been pioneers, in a sense, in helping us to see ways in which we can effectively use our ability to recover salary through research efforts. To prime the pump or keep that engine of expansion of our research and patient care capabilities growing by internally generating many of the resources we need to be successful. We've restructured the budget process to provide greater incentives to academic units to raise revenues and cut their costs.

We've reduced costs as well. As you recall, we painfully eliminated 600 FTE funded faculty and staff positions for FY 2003. We restructured our property and liability insurance and we reviewed central commitments, the Anderson Committee, targeting a way of reducing 10 percent of our expenditures through central funds. We hedged our natural gas prices with long-term contracts. We created a web-based auction site to facilitate the sale of surplus materials, which we just brought online this year and we think can be quite helpful.

But what about going forward? What are some of the ideas we have about what we can do over the next 12 to 18 months that will facilitate our efforts to find the resources needed to go forward with the Academic Plan? What are some of the expanding or new opportunities available on the revenue side?

We think we need to be more aggressive about our federal agenda. President Holbrook is looking for the right person to come in as the vice president for Government Relations to work with the other appropriate complementary groups on campus, to make certain that we are as aggressive and as effective in getting our issues addressed at the federal level.

We can work to increase extramural sponsorship of research. We've heard reports on what we're doing, but we obviously can do a great deal more. We can increase our cost recovery rate or at least work toward that on sponsored research. We have a review coming up this spring and we're positioning ourselves to make as effective a case as possible. As I mentioned earlier, we've already begun a process, but we can do a lot better with respect to increasing salary recovery through extramural funding and increasing our indirect cost recoveries.

In that regard on the revenue side, the way we've changed the budget process is worth keeping in mind. Going forward as new indirect cost funds are being brought into the University, those resources are now going back directly to the units that generate them. One hundred percent of the marginal indirect cost recoveries go back to the units that generate them. That ought to serve as a substantial incentive and a tool for areas that are successful in extramural funding to heighten their efforts and, as a consequence, be much more successful.

We need to expand our opportunities for private giving. That's a daunting task. We've had an extraordinary record in the past, but as you've seen through reports that you're getting from our development people, even as difficult as the

PRESENTATION ON BUDGET/LONG-TERM RESOURCE STRATEGIES (contd)

Provost Ray: (contd)

current economic circumstances are, we're actually bringing resources in at record or near record levels through the development process. So we have an extraordinary team and we know we can even exceed the extraordinary accomplishments of the past in that area.

Selective program expansion, including distributive learning, represent other ways we can reach out to the various communities that we serve. You've heard presentations on our PharmD and nursing programs that have electronic courses. Obviously, we have a long history of distributive learning programs through the College of Engineering and the Fisher College of Business is moving aggressively in that direction as well. We think that represents a substantial area of potential growth.

Obviously, we need to expand our entrepreneurial partnerships where appropriate. We're trying to do that through SciTech and through enhancement of the resource base that we have available for technology transfer, licensing, and patenting. If you look at our performance relative to our benchmark peers, we're substantially behind where we ought to be if we're to compete with them in this dimension. I think this is an area that will get a good deal of attention in the future.

Let me stop there and ask Bill Shkurti to come forward and talk a little bit about the cost side.

Mr. William J. Shkurti:

Thank you, Ed. As Ed mentioned, he's talked about the areas of additional revenues that we hope to emphasize over the next 12 to 18 months. What I'll talk about is the cost-saving side and we've listed five major areas there. I'll phrase these as questions. The details are really in the materials and you can expand upon it if you like.

The first one involves our core administrative system. The question is how can we get an improved performance from the system such as our planning and construction of large capital projects and the purchases of goods and services. Six hundred and fifty million dollars a year go through these systems and we think we use our size to try and do the best we can, but sometimes our size is also a challenge in doing this.

The executive deans have proposed a process where the University will systematically review all of its core administrative systems over the next couple of years. We think if we start with the two systems I mentioned, there should be some potential there that it should show up in the next 12 to 18 months.

The second area is an area of challenge that all employers are facing. That is the issue of how can we reduce the rate of increase in our health benefits costs while preserving access and quality for University faculty and staff, as well as our students. Unlike most employers, we're very fortunate to have a wonderful medical center here on campus. The question is how can we leverage that arrangement to have the best of both worlds, which is high quality and low cost.

The third area is something most families are familiar with. Unfortunately lower interest rates mean lower earnings on the investment side, but they also can mean lower costs in terms of mortgages for families and in terms of the borrowing we do for construction. In fact, the Fiscal Affairs Committee of the Board already approved a resolution earlier this morning, which will allow the

PRESENTATION ON BUDGET/LONG-TERM RESOURCE STRATEGIES (contd)

Mr. Shkurti: (contd)

University to refinance a portion of its debt and save at least \$2.5 million over the next five years.

The next area deals with energy, which is a somewhat volatile market. Our question that we need to ask ourselves is how can we use changes in the energy market, particularly regarding competition to reduce our utility cost. The issue here is an interesting challenge, because our utility costs per student at Ohio State are the lowest in the Big Ten. So we already have a tremendous competitive advantage. The problem is, how do we keep that in an area where there's more national competition and competition tends to level those costs out across the country. So that will be an interesting challenge for us, but there is \$37 million a year at stake in that issue.

Finally, how can we use the lessons of the late 1990s -- regarding the lessons we learned very painfully about how to install or how not to install major computer systems -- to establish a pattern of doing the right thing as we upgrade the existing system and install the new system. Further work on keeping our systems running is likely to cost another \$10-\$20 million annually for the foreseeable future. So, we need to make sure we're getting the best return on that investment.

I'd like to next turn to implications and where we go from here. I think the major thoughts we'd like to leave you with is first of all, the academic planning and the budget process cannot in this day and age just be a discussion of how to spend more. As Ed mentioned, and as President Holbrook has mentioned, excellence does not come on the cheap and we need to recognize that. But excellence also does not come just from spending money. You have to spend the right amount of money in the right places in a disciplined and focused way. Our goal here is to identify at least \$20-\$25 million in additional cost savings, in cost avoidance, that we can achieve over the next five years, and the five items I mentioned are the start on that.

In terms of next steps, what we would propose is to come back to the Board in April and present more detailed recommendations for your review based on the initiatives that we've talked about, including specific goals, assignments, and timetables. In July we would approve the final plans as part of the FY 2004 budget so it becomes integrated with that process. Then in December, we'll do a mid-year progress report and do progress reports thereafter on a regular basis through the whole five-year period.

In conclusion, what I'd like to summarize is the following: OSU has a good track record. Controlling our expenses is not something new -- we've been doing it for decades -- but we need to do more because of the environment and achieving our academic goals requires it. We think there are opportunities both for revenue generation and for cost reductions. In other words, just doing one without the other isn't going to get us where we need to go.

As I mentioned earlier, more money is not an end in itself, but resources are important and you can't reach the level of excellence we hope to do on a shoestring.

Finally, our success in achieving our academic goals not only requires us to manage our costs effectively and look for other revenue sources, but it also requires a firm base of tuition and of state support. So we say to our students that we need to do everything we can to use your tuition dollars wisely, but your tuition dollars need to be sufficient for us to give you the services you need and

PRESENTATION ON BUDGET/LONG-TERM RESOURCE STRATEGIES (contd)

Mr. Shkurti: (contd)

deserve. And we say to our state officials and to the taxpayers, you have a right to expect us to use your tax dollars efficiently, but the state has to be in a position supporting its state universities in the same way that other states who are competing with us are doing, or we're going to fall farther behind.

I hope this gives you a sense of what some of the long-term issues are. Ed and I will be glad to answer any questions you might have on where we go from here.

Mr. McFerson:

We heard in Dr. Holbrook's report the forecast of state revenues for this fiscal year and next fiscal year, and I'm sure that your work is predicated upon those kinds of forecasts. What if those state forecasts don't come to pass? What are you thinking about then, Bill?

Mr. Shkurti:

Our first effort is to try to make sure that the governor's plan or what's equivalent to it is passed, because that certainly would make our job easier. We do, however, but we always have to hope for the best and prepare for the worst. So if the worst happens and there's a downturn, we alert our units -- because a lot of this gets passed down in our decentralized system -- to be flexible and be prepared to do budget cuts.

We also set in the budget cut scenario certain things we protect at all costs. For example, student scholarships and filled faculty lines, because those are our bread and butter. If we cut back on those, we shoot ourselves in the foot and we make our revenue problems worse.

We also have a rainy day fund of \$10 million, which sounds like a lot but it's only a small part of the budget. This can buy us some time to work through these problems, but obviously we have that option as well.

We have the option of finding other revenue sources and we already have been trying to do that, as we talked about today. Another option which we would be very reluctant to use is raising tuition and we hope to not do that in mid-year. Once again, I would like to say not do mid-year tuition increases unless absolutely forced to by very dire circumstances. Then also we want to take a longer-term view and try to have time to implement both the revenue enhancement and the cost reduction strategies we talked about today.

Provost Ray:

You know it's not really short term, but you've got to start something now if you're hoping it will have an effect in a year or two, or three or four. We're actually making some fairly significant changes, again on the revenue and cost side. For example, we've changed the way we do budgets. But as part of that, we've identified a re-basing process to, in a sense, redirect existing resources within the University in a focused, targeted way to where they need to be in alignment with the Academic Plan. Even apart from current circumstances, we're on a course to redirect, on a continuing basis, up to \$10 or \$12 million of existing University resources in a targeted way to those programs that we think will play a critical role in moving the University forward with respect to implementation of the Academic Plan.

PRESENTATION ON BUDGET/LONG-TERM RESOURCE STRATEGIES (contd)

Provost Ray: (contd)

I also already mentioned a little bit about the rules for going forward in the new budget process that we believe create incentives for people to be more entrepreneurial. Whether it's through externally funded research and being able to capture the indirect costs, or whether it's in terms of being innovative about existing academic programs to bring more tuition and state share of instruction dollars to the units, or through distributed learning programs that could bring more resources to the units, the new budget process supports that on the revenue side.

We've also allocated, to the extent that it seemed appropriate, costs out to units. So we have a lot of helpers out there who understand that being cost effective where they live and where they operate will provide them more flexible resources to move their academic programs forward. So the budget process we think will help.

As you know, last year we passed a change in the tenure and promotion period for regular faculty in the College of Medicine and Public Health with patient clinical care responsibilities. We did that because we understand -- given the market that medicine has to compete in -- for their faculty to be as effective as they need to be, they need to bring new ideas and new techniques into patient care surroundings. They also need the time to be able to get that job done at the same time that they're providing substantial patient care now. We think giving them that flexibility will help them keep going forward.

Today, the Board is being asked to approve an elimination of the cap on clinical faculty appointments in the clinical areas in the College of Medicine and Public Health. I know Fred can talk about this more eloquently than I can, but that's absolutely essential for many of the plans that we have to grow our research and patient care enterprise in the health sciences. It's a really critical change in the way we do business here at the University.

Finally, the last thing I would mention is I just gave a speech to the University Senate about what we need to do to organize ourselves to be more effective in the arts and sciences, which are at the heart of this institution and absolutely essential to our achieving our goals in the Academic Plan. The proposal that I've put out there -- and I've asked people to get comments back to me on by the end of March -- has some very targeted purposes. The shortest punch line I would give for that reorganization is it is intended to consolidate and streamline administrative activities across the arts and sciences. It will redirect existing resources and create an entry point for new resources to promote arts and sciences programs and activities writ large, which will allow that part of the University to advance and play a leading role in our being able to implement the Academic Plan.

So these are things that are going to realize benefits starting next year, but it will take a number of years. They all represent elements of what we are doing now, because we understand we have a long-term challenge and we need to be as creative as possible, both in creating resources and in economizing on the uses of our existing resources.

As Bill mentioned, it is not all just about tuition dollars or the state's share of instruction. We need that strong foundation, but we need to take ownership in

PRESENTATION ON BUDGET/LONG-TERM RESOURCE STRATEGIES (contd)

Provost Ray: (contd)

the problem of making sure we have the wherewithal to provide this institution with the success of the Academic Plan that we're all committed to.

(See Appendix XXXII for background information, page 749.)

--0--

STUDENT RECOGNITION AWARD

Ms. Habib:

The Student Recognition Award is presented each month by the Board of Trustees to a student in honor of the student's achievement in his or her area of study, service to the University and/or community, and/or research achievements that have been a credit to the college and the University.

This month's recipient is Safuratu Yetunde Aranmolate, who was nominated by Dean Kronmiller in the College of Dentistry. Ms. Aranmolate is a fourth-year dental student currently enrolled full-time in the doctoral program. Her anticipated graduation is June 2003 and her academic record is strong, as she currently has a cumulative GPA of 3.28 and she finished Autumn Quarter with a GPA of 3.785.

She is a very dedicated and committed student who works hard and is very proactive in her approach to her dental education. Ms. Aranmolate has also successfully engaged in the College student research program. She is a positively visible student in the College. Ms. Aranmolate's commitments to service activities are commendable and far exceed other students in the program.

She is presently commissioned in the Army Reserve as a 1st Lieutenant. She is the president of the Student National Dental Association – Ohio State Chapter -- and is an active participant in various other professional student groups. Ms. Aranmolate has an excellent service record in college-related activities, participating in health fairs and providing oral hygiene instruction to underprivileged elementary school students in the Columbus Public Schools.

She is also an active member of her church's, St. Paul A. M. E., Step Program, which provides tutorial support in general science for fourth and sixth graders in preparation for the Ohio Standardized Proficiency Exam. She has also coordinated programs for the homeless. Recently, she was awarded the Harold E. McDaniel Family Fund Scholarship through the Columbus Foundation in Columbus, Ohio. Yetunde also served two weeks during July 2002 delivering oral health care at the Pine Ridge South Dakota Indian Reservation.

Being a student myself, it is a great honor for me to be able to present a student like Yetunde to the Board of Trustees. The Board appreciates the chance to meet students, especially ones who exemplify exactly how bright and committed the students at Ohio State really are.

Congratulations, Yetunde.

STUDENT RECOGNITION AWARD (contd)

Mr. Patterson:

As long as I've been on the Board, I continue to be impressed. I know it's just a small sampling of the outstanding students that we have that we wish that we could recognize.

--0--

CONSENT AGENDA

President Karen A. Holbrook:

We have thirteen resolutions on the Consent Agenda today as follows:

ESTABLISHMENT OF A PH.D. DEGREE PROGRAM IN COMPARATIVE STUDIES

Resolution No. 2003-76

Synopsis: Establishment of a Ph.D. degree program in Comparative Studies in the College of Humanities is proposed.

WHEREAS there is a growing national and international trend toward comparative and interdisciplinary scholarship in the humanities – across geographic regions, historical periods, cultural domains, theoretical perspectives and methodological strategies; and

WHEREAS the proposed program will offer specializations in comparative literature, folklore, religious studies, science and technology studies, and comparative ethnic and American studies -- areas of research and teaching strength among the faculty; and ones that make this program distinctive nationally; and

WHEREAS the proposed program will prepare future scholars for academic positions and for service to private and public agencies and institutions; and

WHEREAS the proposed program represents the most recent step in a well-planned development of the academic mission of the department; and

WHEREAS the proposal adheres to the Ohio Board of Regents' Guidelines for Approval of Graduate Degree Programs; and

WHEREAS the proposal was discussed and approved by the Research and Graduate Council, the Council on Academic Affairs subcommittee, the full Council on Academic Affairs, and was approved by the University Senate at its January 16, 2003 meeting:

NOW THEREFORE

BE IT RESOLVED, That the proposal to establish a Ph.D. degree program in Comparative Studies in the College of Humanities is hereby approved to be effective upon the approval of the Ohio Board of Regents.

EXCEPTION TO RULE 3335-48-03

Resolution No. 2003-77

Synopsis: An exception to rule 3335-48-03 of the Administrative Code, to eliminate the caps on the number of regular clinical faculty in clinical departments in the College of Medicine and Public Health, is proposed.

WHEREAS rule 3335-48-03 of the Administrative Code states that regular clinical faculty may comprise no more than forty percent of the total regular faculty (as defined in rule 3335-5-19 of the Administrative Code) in each of the departments, schools, and colleges of the health sciences and no more than twenty percent of the tenure-track faculty in other departments, schools, and colleges; and

WHEREAS the College of Medicine and Public Health has requested an exception to this rule (3335-48-03) to eliminate the caps in the clinical departments in that College; and

WHEREAS the clinical departments in the College of Medicine and Public Health affected by this exception would be: Anesthesiology, Emergency Medicine, Family Medicine, Internal Medicine, Neurology, Obstetrics and Gynecology, Ophthalmology, Otolaryngology, Orthopedics, Pathology, Pediatrics, Physical Medicine and Rehabilitation, Psychiatry, Radiology, and Surgery; and

WHEREAS the proposed recommendation for this exception to rule 3335-48-03 of the Administrative Code for the College of Medicine and Public Health was approved by the University Senate on January 16, 2003:

NOW THEREFORE

BE IT RESOLVED, That this exception to rule 3335-48-03 of the Administrative Code for the College of Medicine and Public Health be adopted as recommended by the University Senate.

AMENDMENTS TO THE RULES OF THE UNIVERSITY FACULTY

Resolution No. 2003-78

Synopsis: Approval of the following amendments to the *Rules of the University Faculty* are recommended.

WHEREAS the University Senate pursuant to rule 3335-1-09 of the Administrative Code is authorized to recommend through the President to the Board of Trustees the adoption of amendments to the *Rules of the University Faculty* as approved by the University Senate; and

WHEREAS the proposed changes in the *Rules of the University Faculty* were approved by the University Senate on January 16, 2003:

New Rule

3335-5-4817 Committee for evaluation of central administrators.

(A) Membership.

The committee for evaluation of central administrators shall consist of eight members.

(1) Six tenured faculty members with staggered terms.

AMENDMENTS TO THE RULES OF THE UNIVERSITY FACULTY (contd)

New Rule (contd)

- (a) Six tenured faculty members appointed by the president from a slate nominated by the executive committee of faculty council.
 - (b) The term of service is three years. Members shall not be reappointed to a second term until they have been off the committee for at least two years, except that a member may be reappointed immediately if that person was appointed to fill a vacant position with a remaining term of less than two years.
 - (c) A chair will be elected yearly from among the faculty members serving on the committee.
- (2) Two administrators, appointed by and serving at the pleasure of the president.
- (B) Duties and responsibilities.
- (1) During autumn quarter, the Executive Committee of Faculty Council shall meet with the president and provost to identify two central administrators for review. All vice provosts, senior vice provosts, vice presidents, and senior vice presidents are eligible to be reviewed.
 - (2) The review panels shall be responsible for evaluating the effectiveness of the central administrator and the office in carrying out the responsibilities of the office. The review may begin immediately after the review panel is appointed but no later than autumn quarter of the following academic year.
 - (3) The review panel will, after its review and evaluation, present a written report to the president and provost. The review panel will also send a copy of the written report to the person being reviewed.
 - (4) The chair of the committee shall monitor the activities of the review panels and advise the review panels on matters of procedure.
- (C) Organization of review panels.
- In the spring preceding the academic year in which the review is to be conducted, the committee shall organize itself into two review panels, each review panel to be organized as follows:
- (1) Three regular faculty members from the committee, one of whom is designated by the president or provost, in consultation with the committee chair, as chair of the review panel.
 - (2) One administrator from the committee.
 - (3) One student member appointed by the provost if a vice provost or senior vice provost is under review or by the president if a vice president or senior vice president is being reviewed.
 - (4) One staff member appointed by the provost if a vice provost or senior vice provost is under review or by the president if a vice president or senior vice president is being reviewed.
 - (5) One to three additional regular faculty members, if needed, nominated by the committee chair and appointed by the president or provost after consultation with the committee. (B/T 2/7/2003)

AMENDMENTS TO THE RULES OF THE UNIVERSITY FACULTY (contd)

NOW THEREFORE

BE IT RESOLVED, That the foregoing amendments to the *Rules of the University Faculty* be adopted as recommended by the University Senate.

HONORARY DEGREES

Resolution No. 2003-79

Synopsis: The awarding of honorary degrees is recommended for approval.

WHEREAS the Committee on Honorary Degrees and the University Senate, pursuant to rule 3335-5-488 of the Administrative Code, have approved for recommendation to the Board of Trustees awarding of honorary degrees as listed below:

Durbin Feeling	Doctor of Humane Letters
Adrienne Kennedy	Doctor of Literature

NOW THEREFORE

BE IT RESOLVED, That the above honorary degrees be awarded in accordance with the recommendation at a time convenient to the University and the recipients.

PERSONNEL ACTIONS

Resolution No. 2003-80

BE IT RESOLVED, That the personnel actions as recorded in the Personnel Budget Records of the University since the December 6, 2002 meeting of the Board, including the following Appointments/Reappointment, Change in Term, Appointment of Chairperson, Leaves of Absence Without Salary, Professional Improvement Leaves, and Emeritus Titles as detailed in the University Budget be approved.

BE IT FURTHER RESOLVED, That the Medical Staff and Allied Health Professional Appointments approved January 21, 2003, by The James Cancer Hospital Board, be ratified.

Appointments

Name: JOHN R. MEYER
Titles: Interim Vice President/Interim President
Office: Development/University Foundation
Effective: February 1, 2003
Present Position: Associate Vice President for Development

Name: CYNTHIA J. ROBERTS
Title: Associate Professor (The Torrence A. Makley Research Professorship)
Department: Ophthalmology
Term: April 1, 2003, through June 30, 2007

PERSONNEL ACTIONS (contd)

Reappointment

Name: JOSE B. CRUZ, JR.
Title: Professor (The Howard D. Winbigler Designated Chair in Engineering)
College: Engineering
Term: July 1, 2002, through June 30, 2007

Change in Term

Name: JOHN A. POWELL
Title: Director and Professor (The Gregory H. Williams Chair in Civil Rights and Civil Liberties)
Institute/College: The William E. Kirwan Institute for the Study of Race and Ethnicity in the Americas/The Michael E. Moritz College of Law
Term: Change term from January 15, 2003 to December 9, 2002, through June 30, 2006

Appointment of Chairperson

January 1, 2003 through June 30, 2003

Evolution, Ecology and Organismal Biology

Peter S. Curtis*

*Acting

Leaves of Absence Without Salary

HASSAN Y. ALY, Associate Professor, Department of Economics (Marion Campus), effective Winter Quarter, Spring Quarter, and Autumn Quarter 2003, to accept an appointment at Zayed University in the United Arab Emirates.

DOUGLAS R. COLE, Assistant Professor, College of Law, effective January 14, 2003, through January 13, 2004, to serve as Chief Deputy Attorney General for the State Solicitor Section of the Ohio Attorney General's Office.

Professional Improvement Leave

MAUREEN H. DONOVAN, Associate Professor, University Libraries, effective Summer Quarter and Autumn Quarter 2003, and Winter Quarter and Spring Quarter 2004.

Professional Improvement Leave—Cancellation

KATHRYN A. EATON, Associate Professor, Department of Veterinary Biosciences, effective January 1, 2003, through December 31, 2003.

Emeritus Titles

JUNE W. ALLISON, Department of Greek and Latin, with the title Professor Emeritus, effective April 1, 2003.

BARBARA H. JAMES, Ohio State University Extension, with the title Professor Emeritus, effective February 1, 2003.

GARY J. KOCIBA, Department of Veterinary Biosciences, with the title Professor Emeritus, effective February 1, 2003.

ANTHONY P. LIBBY, Department of English, with the title Professor Emeritus, effective April 1, 2003.

PERSONNEL ACTIONS (contd)

Emeritus Titles (contd)

FRANK O'HARE, Department of English, with the title Professor Emeritus, effective April 1, 2003.

BRADFORD T. STOKES, Department of Physiology and Cell Biology, with the title Professor Emeritus, effective April 1, 2003.

JOHN D. ROHRER, Ohio State University Extension, with the title Associate Professor Emeritus, effective February 1, 2003.

DOUGLAS L. DILL, Ohio State University Extension, with the title Assistant Professor Emeritus, effective February 1, 2003.

Medical Staff and Allied Health Professional Appointments (The Arthur G. James Cancer Hospital and Richard J. Solove Research Institute)

December 2002/January 2003

Faiq S. M. Akhter, M.D., Community Associate, Internal Medicine, Cardiology, 12/19/2002-6/2/2003

Onsy Ayad, M.D., Associate Attending, Pediatrics, Critical Care, 12/19/2002 - 6/2/2003

Sandeep Chopra, M.D., Community Associate, Internal Medicine, Cardiology, 12/19/2002 - 6/2/2003

James P. Ellis, D.D.S., Associate Attending, Dentistry, Oral/Maxillofacial Surgery, 1/21/2003 - 6/30/2003

Stephen Houff, M.D., Associate Attending, Internal Medicine, General Medicine, 12/19/2002 - 6/2/2003

Yiqun Hu, M.D., Ph.D., Associate Attending, Neurology, 1/21/2003 - 6/30/2003

Lin Li, M.D., Associate Attending, Anesthesiology, 12/19/2002 - 6/2/2003

Joel D. Macy, M.D., Community Associate, Family Medicine, 12/19/2002 - 6/2/2003

Christopher J. Madden, M.D., Associate Attending, Surgery, Neurologic Surgery, 1/21/2003 - 7/7/2003

Michael Meleca, M.D., Community Associate, Internal Medicine, Cardiology, 12/19/2002 - 6/2/2003

Crystl Osborn, Community Associate, Psychiatry, 12/19/2002 - 6/2/2003

Osita E. Okpalaopa, Associate Attending, Internal Medicine, General Medicine, 12/19/2002 - 6/2/2003

Howard A. Paskett, P.A.C., Allied Health Professional, Orthopaedics, 1/21/2003 - 7/7/2003

Rajendra Patel, M.D., Community Associate, Internal Medicine, Cardiology, 12/19/2002 - 6/2/2003

Kamal Pohar, M.D., Attending, Surgery, Urology, 12/19/2002 - 6/2/2003

Mohini S. Rao, M.D., Associate Attending, Anesthesiology, 1/21/2003 - 7/7/2003

Radu Savenau, M.D., Associate Attending, Psychiatry, 12/19/2002 - 6/2/2003

Benjamin C. Sun, M.D., Associate Attending, Surgery, Thoracic-Cardio Surgery, 1/21/2003 - 7/7/2003

Requests for Additional or Special Privileges:

Kristine Browning, C.N.P., Allied Health Professional, Internal Medicine, Prescriptive Authority, 12/19/2002 - 6/2/2003

Maureen Buckner, C.N.P., Allied Health Professional, Internal Medicine, Prescriptive Authority, 1/21/2003 - 6/30/2003

Joel Weaver, D.D.S., Ph.D., Associate Attending, Dentistry, Anesthesiology, 12/19/2002 - 6/2/2003

PERSONNEL ACTIONS (contd)

Medical Staff and Allied Health Professional Appointments (The Arthur G. James Cancer Hospital and Richard J. Solove Research Institute) (contd)

December 2002/January 2003 (contd)

Provisional to Full Appointments:

Tatal Attar, M.D., Associate Attending, Internal Medicine, Cardiology, 12/19/2002-6/30/2003
Udayan Bhatt, M.D., Associate Attending, Internal Medicine, Nephrology, 1/21/2003-6/30/2003
William Hicks, M.D., Attending, Internal Medicine, Hematology/Oncology, 12/19/2002-6/30/2003
Richard P. Lewis, M.D., Associate Attending, Internal Medicine, Cardiology, 12/19/2002-6/30/2003
Gwyn Londeree, M.D., Associate Attending, Internal Medicine, Dermatology, 12/19/2002-6/30/2003
Gerard Lozanski, M.D., Associate Attending, Pathology, 1/21/2003-6/30/2003
MaryBeth Luca, D.O., Associate Attending, Internal Medicine, Dermatology, 1/21/2003-6/30/2003
Douglas Massick, M.D., Associate Attending, Otolaryngology, 12/19/2002-6/30/2004
J. Paul Monk, M.D., Attending, Internal Medicine, Hematology/Oncology, 12/19/2002-6/30/2004
Carl D. Morrison, M.D., Associate Attending, Pathology, 1/21/2003-6/30/2004
Subha V. Raman, M.D., Associate Attending, Internal Medicine, Cardiology, 1/21/2003-6/30/2004
Kottil W. Rammohan, M.D., Associate Attending, Neurology, 1/21/2003-6/30/2004
Ferdinand Santos, M.D., Community Associate, Anesthesiology, 1/21/2003-6/30/2004
John R. Schwarzell, M.D., Associate Attending, Surgery, General Surgery, 1/21/2003-6/30/2004
Ping Wen, M.D., Ph.D., Associate Attending, Pathology, 1/21/2003-6/30/2004
Kelly Zyniewicz, M.D., Associate Attending, Internal Medicine, Dermatology, 12/19/2002-6/30/2004

RESOLUTIONS IN MEMORIAM

Resolution No. 2003-81

Synopsis: Approval of Resolutions in Memoriam is proposed.

RESOLVED, That the Board adopt the following Resolutions in Memoriam and that the President be requested to convey a copy to the families of the deceased.

Homer A. Anderson

The Board of Trustees of The Ohio State University expresses its sorrow upon the death on November 30, 2002, of Homer A. Anderson, M.D., Clinical Professor Emeritus in the Department of Pediatrics.

Dr. Anderson graduated from Muskingum College in 1935, and worked as a coach and teacher at New Concord High School. He received his Doctor of Medicine degree from The Ohio State University College of Medicine in 1943. Dr. Anderson was the chief of Nurseries and Morning Dispensary at the Harriet Lane Home and Johns Hopkins Hospital in Baltimore from 1945-46. In 1946, Dr. Anderson was appointed to the medical staff at Children's Hospital and began his practice as a community physician.

RESOLUTIONS IN MEMORIAM (contd)

Homer A. Anderson (contd)

From 1953-55, Dr. Anderson was a captain in the U.S. Air Force and served as chief of Pediatrics at Bolling Air Force Base, Washington, D.C. He served as president of the Central Ohio Pediatrics Society and became a member of the clinical faculty at The Ohio State University's Department of Pediatrics in 1957. He was president of the medical staff at Children's Hospital in 1963 and the following year served as president of the Columbus Academy of Medicine. Dr. Anderson was clinical professor in OSU's Department of Pediatrics from 1968-93. Upon his retirement, he was awarded clinical professor emeritus status in the Department of Pediatrics. In 1999, he received the Career Contribution Award from Children's Hospital.

Dr. Anderson served his profession at the highest level. He was a member of the American Academy of Pediatrics, and was an accomplished teacher who combined his passion for teaching with his role as a beloved community physician. He was also an active member of his community, serving as a member of the Broad Street Presbyterian Church, and was a veteran of the U.S. Air Force.

On behalf of the University community, the Board of Trustees expresses to the family of Dr. Homer A. Anderson its deepest sympathy and sense of understanding of their loss. It was directed that this resolution be inscribed upon the minutes of Board of Trustees and that a copy be tendered to his family as an expression of the Board's heartfelt sympathy.

Howard E. Frisbee

The Board of Trustees of The Ohio State University expresses its sorrow upon the death on January 3, 2003, of Howard E. Frisbee, Professor Emeritus in the Ohio State University Extension.

Professor Frisbee was born April 16, 1917, in Andes, New York. He received a bachelor's degree in journalism from Westminster College in 1951, and a master's degree in journalism in 1961 from Cornell University.

Professor Frisbee began his Extension career in 1956 as an assistant agricultural editor at Ohio State. He retired in 1982 as the associate head and editor of Ohio State University Extension.

During Professor Frisbee's career with Extension, he significantly influenced the quality of educational literature distributed by this organization. His communicative skills and talents in writing, editing, and publishing had a major impact on the journalistic endeavors of both faculty and students. He was a prolific writer and authored hundreds of articles for daily or weekly newspapers and features which appeared in magazines and professional journals across the country.

In addition, he served as the *Buckeye Triune* (student publication for the College of Agriculture) advisor for many years. He edited and processed 4-H literature for more than 10 years and played an important role in organizing the 4-H Creative Writing project. He was a past president of the Ohio Extension Professors Association and the University Faculty Photo Society. Howard Frisbee was a member of the Epsilon Sigma Phi, the Extension honorary fraternity, and Gamma Sigma Delta, an agricultural honorary fraternity.

These contributions in providing excellent Extension educational programs during his career earned him the respect and admiration of co-workers and associates throughout the state and nation.

On behalf of the University community, the Board of Trustees expresses to the family of Professor Emeritus Howard E. Frisbee its deepest sympathy and sense of understanding of their loss. It was directed that this resolution be inscribed upon the minutes of the Board of Trustees and that a copy be tendered to his family as an expression of the Board's heartfelt sympathy.

RESOLUTIONS IN MEMORIAM (contd)

William B. McBride

The Board of Trustees of The Ohio State University expresses its sorrow upon the death on November 24, 2002, of Dr. William B. McBride, Professor Emeritus in the College of Education and School of Music.

Professor McBride grew up in Lima, Ohio, where he graduated from Lima Central High School. He received two undergraduate degrees from Ohio Wesleyan University: an A.B. degree in 1931 and a Bachelor of Music degree in 1932. He received a Masters of Art in 1932 from Columbia University and a Doctorate of Education degree from the University of Florida in 1951. After teaching at public schools in Morrow and Allen Counties in Ohio, he joined the faculty of The Ohio State University School of Music in 1939. Following his years on the School of Music faculty, Dr. McBride joined the dean's staff in the College of Education in 1959, and became assistant dean of the College in 1965. Upon his retirement in 1970, he was named Professor Emeritus.

William McBride served his profession at the highest level. He was president of the Ohio Music Education Association, president of the North Central Division of the Music Educators National Conference, and also national president of Music Educators National Conference (1956-58). In addition, he served as national president of Phi Mu Alpha Sinfonia, a national honorary music fraternity. Professor McBride received the Distinguished Service Award of the Ohio Music Education Association in 1958.

Following his retirement, he and his wife, Jo, moved to their summer home in Waverly, Ohio, where he was active in soil conservation and forestry. They later moved to Fort Myers, Florida, for the remainder of their retirement.

Dr. McBride contributed significantly to the fame and reputation of the OSU Marching Band. When Director Manley Whitcomb was drafted just before the 1943 football season, William McBride was asked to direct the Marching Band "for the duration." He was able to keep the band performing on the football field while most other bands either ceased to exist or just played in the stands as a pep band. It is possible that OSU was the only school in the Big Ten to field a marching band during World War II. The challenges of his three years of directing the band included having band members come and go, even during the week; opening up the ranks to woodwind players, singers, horn carriers, "marchers" and even selected high school students to fill out the ranks; and dealing with restrictions on rehearsal time and travel. The TBDBITL Alumni Club presented the Script Ohio Award to Dr. McBride in 1978.

On behalf of the University community, the Board of Trustees expresses to the family of Professor William B. McBride its deepest sympathy and sense of understanding of their loss. It was directed that this resolution be inscribed upon the minutes of the Board of Trustees and that a copy be tendered to his family as an expression of the Board's heartfelt sympathy.

Robert W. McCormick

The Board of Trustees of The Ohio State University expresses its sorrow upon the death on December 13, 2002, of Robert W. McCormick, Professor Emeritus of Agricultural Education.

Robert McCormick was born on December 1, 1921, in Venice, Ohio. He began his educational career in a Butler County one-room school and graduated from Fairfield High School in 1939. He served as a medic in World War II with the 696th Field Artillery Battalion in Europe, earning five campaign ribbons and a Bronze Star.

Professor McCormick earned the B.S. and M.S. degrees in agricultural education at The Ohio State University in 1948 and 1956, respectively. He earned his Ph.D. degree in adult education at the University of Wisconsin as a Kellogg Foundation Fellow in 1959.

RESOLUTIONS IN MEMORIAM (contd)

Robert W. McCormick (contd)

During his 22 years at The Ohio State University, he advised 39 Ph.D. and 45 M.S. students from countries throughout the world. From 1966 until his retirement, he served as assistant vice president for Continuing Education and professor of Agricultural Education.

Since his retirement in 1977, he founded the Columbus World War II Roundtable and authored seven books, including *Cockney*, a history of the 696th Field Artillery Battalion in World War II. Professor McCormick wrote a book about Professor Norton S. Townshend, one of the founders of The Ohio State University and its first professor of agriculture. He and his wife traveled to most of the fifty states and to more than two dozen countries around the world.

On behalf of the University community, the Board of Trustees expresses to the family of Professor Emeritus Robert W. McCormick its deepest sympathy and sense of understanding of their loss. It was directed that this resolution be inscribed upon the minutes of the Board of Trustees and that a copy be tendered to his family as an expression of the Board's heartfelt sympathy.

REPORT OF RESEARCH CONTRACTS AND GRANTS

Resolution No. 2003-82

Synopsis: The reports on research and other sponsored program contracts and grants and the summaries for November and December 2002 are presented for Board acceptance.

WHEREAS monies are solicited and received on behalf of the University from governmental, industrial, and other agencies in support of research, instructional activities, and service; and

WHEREAS such monies are received through The Ohio State University Research Foundation:

NOW THEREFORE

BE IT RESOLVED, That the research agreement between The Ohio State University and The Ohio State University Research Foundation for the contracts and grants reported herein during the months of November and December 2002 be approved.

REPORT ON UNIVERSITY DEVELOPMENT

Resolution No. 2003-83

Synopsis: The report on the receipt of gifts and the summary for December 2002 are presented for Board acceptance.

WHEREAS monies are solicited and received on behalf of the University from alumni, industry, and various individuals in support of research, instructional activities, and service; and

WHEREAS such gifts are received through The Ohio State University Development Fund and The Ohio State University Foundation; and

WHEREAS this report includes the establishment of The Edwin D. Dodd Professorship in Management and The Charles R. Webb Designated Professorship in Finance; and

REPORT ON UNIVERSITY DEVELOPMENT (contd)

WHEREAS this report includes the establishment of twenty-three (23) new named endowed funds and the amendment of four (4) named endowed funds:

NOW THEREFORE

BE IT RESOLVED, That the acceptance of the report from The Ohio State University Development Fund and The Ohio State University Foundation during the month of December 2002 be approved.

TOTAL UNIVERSITY PRIVATE SUPPORT

July through December
2001 Compared to 2002

GIFT RECEIPTS BY DONOR TYPE

	Dollars July through December		
	<u>2001</u>	<u>2002</u>	<u>%Change</u>
Individuals:			
Alumni (Current Giving)	\$21,576,008	\$22,802,951	6
Alumni (From Bequests)	<u>2,356,490</u>	<u>2,134,846</u>	(9)
Alumni Total	\$23,932,498	\$24,937,797	4
Non-Alumni (Current Giving)	\$9,223,644	\$11,195,137	21
Non-Alumni (From Bequests)	<u>22,548,545</u>	<u>3,552,699</u>	39
Non-Alumni Total	\$11,772,189	\$14,747,836	25
Individual Total	\$35,704,687	\$39,685,633	11 ^A
Corporations/Corp/Foundations	\$22,362,755	\$24,017,386	7 ^B
Private Foundations	\$10,545,716	\$11,861,272	12 ^C
Associations and Other Organizations	<u>\$2,520,322</u>	<u>\$4,660,065</u>	85 ^D
Total	\$71,133,480	\$80,224,356	13

NOTES

- A Individual giving is up 11% largely due to the fact that gifts of \$10,000 or more are up 16% (306 gifts for \$25.4 million last year; 360 gifts for \$29.5 million this year).
- B Giving from corporations at the \$10,000 or more level is up 11% for July-December, 2002 (\$20.3 million from 378 gifts this year; \$18.3 million from 354 gifts last year).
- C Gifts at the \$10,000 or more level from foundations are up 14% for July-December, 2002 compared with the same period last year (111 gifts for \$10.0 million last year; 135 gifts for \$11.4 million this year).
- D Giving from associations and other organizations at the \$10,000 or more level is up 138% for July-December of the fiscal year (\$3.8 million from 58 gifts this year; \$1.6 million from 50 gifts last year).

REPORT ON UNIVERSITY DEVELOPMENT (contd)

TOTAL UNIVERSITY PRIVATE SUPPORT (contd)

July from December
2001 Compared to 2002

GIFT RECEIPTS BY PURPOSE

	Dollars July through December		
	<u>2001</u>	<u>2002</u>	<u>% Change</u>
Gift Receipts to Current Use and Endowment Funds:			
Buildings/Equipment	\$13,332,675	\$15,969,336	20
Faculty Support	\$5,957,030	\$8,922,021	50
Program Support	\$38,526,076	\$40,318,508	5
Student Financial Aid	\$7,995,846	\$10,415,568	30
Annual Funds-Colleges/Departments	\$4,647,342	\$4,175,277	(10)
Annual Funds-University	<u>674,511</u>	<u>\$423,646</u>	(37)
Total	\$71,133,480	\$80,224,356	13

GIFT ADDITIONS TO ENDOWMENT

Dollars
July through December

<u>2001</u>	<u>2002</u>	<u>% Change</u>
\$21,404,758	\$25,817,160	21

REPORT ON UNIVERSITY DEVELOPMENT (contd)

THE OHIO STATE UNIVERSITY DEVELOPMENT FUND

	<u>Previous Gifts</u>	<u>Current Gifts</u>	<u>Total Gifts</u>
<u>Establishment of Named Designated Professorship</u>			
The Charles R. Webb Designated Professorship in Finance (Used to provide a designated professorship in the Fisher College of Business; provided by gifts by Charles R. Webb)	\$75,000.00		\$75,000.00
<u>Establishment of Named Endowed Funds</u>			
Katherine Miles Durst and Richard E. Durst Scholarship Fund for Psychology (Used to provide support for Merit Scholars and/or University Scholars as determined by the Honors and Scholars Program; provided by a gift from Katherine Miles Durst and Dr. Richard E. Durst)		\$124,435.00	\$124,435.00
The Kaushalya Chawla Program Fund for Geriatrics Care and Alzheimer's Disease Research in Pharmacy (Used for geriatrics and Alzheimer's disease research; provided by gifts from Mr. Ash Chawla and Mr. Chawla's family, friends, OSU pharmacy alumni and business associates)		\$67,876.00	\$67,876.00
Dr. Beverly Baer Endowed Scholarship Fund for Arts Education (Used to provide a scholarship to an Arts Education student in the College of the Arts; provided by gifts from William D. Baer and Thomas N. Baer)		\$25,000.00	\$25,000.00

Change in Name of Named Endowed Fund

From: The Alumni Club of Orange County and Long Beach Scholarship Fund
To: The Alumni Club of Orange County and Inland Empire Scholarship Fund

Change in Name and Description of Named Endowed Fund

From: The John H. Moore Memorial Loan Fund
To: The John H. Moore Grant and Scholarship Fund

THE OHIO STATE UNIVERSITY FOUNDATION

	<u>Previous Gifts</u>	<u>Current Gifts</u>	<u>Total Gifts</u>
<u>Establishment of Named Endowed Professorship</u>			
The Edwin D. Dodd Professorship in Management (Used to provide a professorship in the Fisher College of Business; provided by a gift from the Edwin D. Dodd Fund at Charities Foundation)		\$750,000.00	\$750,000.00

REPORT ON UNIVERSITY DEVELOPMENT (contd)

THE OHIO STATE UNIVERSITY FOUNDATION (contd)

	<u>Previous Gifts</u>	<u>Current Gifts</u>	<u>Total Gifts</u>
<u>Establishment of Named Endowed Funds</u>			
The Dr. Harold E. "Hal" and Faith B. Barlow Dental Scholarship Fund (Used to provide scholarships in the College of Dentistry; provided by gifts from the estate of Harold E. Barlow)		\$313,907.00	\$313,907.00
The Aida Cannarsa Snow Endowment Fund in the College of the Arts (Used to provide tuition scholarship awards in the College of the Arts; provided by gifts from the estate of Aida Cannarsa Snow)		\$208,333.34	\$208,333.34
The William M. and Darlene Aldrige Music Scholarship Fund (Used to provide scholarships in the School of Music; provided by gifts from the estate of Darlene Aldrige in memory of her husband William M. Aldrige)		\$150,000.00	\$150,000.00
The Harold A. McIntosh Fund (Used to provide scholarships for gay, lesbian, and bisexual students; provided by gifts from the estate of Harold A. "Marc" McIntosh)		\$134,787.00	\$134,787.00
The Dr. Clyde D. Gump Pediatric Dentistry Fund (Used at the discretion of the head of the Section of Pediatric Dentistry; provided by gifts from the estate of Julia Robert Gump in memory of Clyde D. Gump)		\$110,475.22	\$110,475.22
The Robert and Mary Reusche Scholarships for Study Abroad Fund (Used to provide support for study abroad scholarships; provided by gifts from Robert and Mary Reusche)		\$100,000.00	\$100,000.00
The Jimmy Warfield Athletic Training Scholarship Fund (Used to supplement grant-in-aid scholarship costs of athletic training students in the athletic training program; provided by gifts from Linda Warfield and the Cleveland Indians Charities)		\$55,000.00	\$55,000.00
The COBA/Select Sires Dairy Industry Enhancement Endowment Fund (Used to support an extension associate in the Department of Animal Sciences; provided by a gift from COBA/Select Sires)		\$50,000.00	\$50,000.00

REPORT ON UNIVERSITY DEVELOPMENT (contd)

THE OHIO STATE UNIVERSITY FOUNDATION (contd)

	<u>Previous Gifts</u>	<u>Current Gifts</u>	<u>Total Gifts</u>
<u>Establishment of Named Endowed Funds (contd)</u>			
College of Dentistry Endowed Chair Fund in Endodontics (Used to fund a chair that will provide support to a distinguished faculty member in the Section of Endodontics; provided by gifts from Joseph A. Haase, alumni, faculty and friends)		\$47,500.00	\$47,500.00
The Aida Cannarsa Snow Endowment Fund in the Colleges of the Arts and Sciences (Used to provide tuition scholarship awards in the Colleges of the Arts and Sciences; provided by a gift from the estate of Aida Cannarsa Snow)		\$41,666.66	\$41,666.66
The Edmund M. Kagay Scholarship Fund (Used to support study abroad scholarships within the College of Humanities; provided by a gift from the estate of Edmund M. Kagay)		\$40,337.12	\$40,337.12
Wexner Center Education Endowment Fund (Used exclusively to support the Wexner Center's education programs; provided by a gift from an anonymous donor)		\$40,000.00	\$40,000.00
The Donald E. and Martha L. Fogg Alpha Tau Zeta Scholarship Fund (Used for scholarships for student members of the Alpha Tau Zeta Fraternity in the College of Food, Agricultural, and Environmental Sciences; provided by gifts from Donald E. Fogg and Martha L. Fogg)		\$39,357.30	\$39,357.30
The Unverferth House Endowment Fund (Used to support The Unverferth House; provided by gifts from friends of The Unverferth House)		\$25,611.25	\$25,611.25
The Robinson Craig Fendrick – Gwynne Conservation Fund (Used to provide support for the Gwynne Conservation Area at the Molly Caren Agriculture Center; provided by gifts from the Farm Science Review Alumni Association and the Gwynne Conservation Area Committee in cooperation with members of "Baby Craig's" family and friends)		\$25,571.00	\$25,571.00
The BBK&C Athletic Scholarship Fund (Used to supplement the grant-in-aid scholarship costs of a member of the varsity football team; provided by gifts from Mr. John V. Johnson II)		\$25,000.00	\$25,000.00

REPORT ON UNIVERSITY DEVELOPMENT (contd)

THE OHIO STATE UNIVERSITY FOUNDATION (contd)

	<u>Previous Gifts</u>	<u>Current Gifts</u>	<u>Total Gifts</u>
<u>Establishment of Named Endowed Funds (contd)</u>			
The Harry T. Mangurian, Jr. MBA Fellowship Fund (Used to provide support to graduate students in the Fisher College of Business; provided by a gift from The Mangurian Foundation, Inc.)		\$25,000.00	\$25,000.00
The Bonna "Sue" and Louis "Clem" Margulis Endowment Fund for Cancer Research (Used to provide support for cancer research at the Comprehensive Cancer Center; provided by a gift from the estate of Bonna "Sue" Margulis)		\$25,000.00	\$25,000.00
The Dr. Arlene Marx and Dr. Larry Mundy Athletic Scholarship Fund (Used to provide scholarship costs of student athletes on the varsity football team; provided by gifts from Dr. Arlene Marx and Dr. Larry Mundy)		\$25,000.00	\$25,000.00
The Paul A. and Betty L. Whittington Endowed Scholarship Fund (Used to support undergraduate students in the College of Food, Agricultural, and Environmental Sciences; provided by gifts from Paul A. and Betty L. Whittington)		\$25,000.00	\$25,000.00
<u>Change in Description of Named Endowed Funds</u>			
The William M. and Darlene Aldrige Agriculture Scholarship Fund			
The Evelyn Michael MBA Fellowship Fund			
Total	<u>\$75,000.00</u>	<u>\$2,474,856.89</u>	<u>\$2,549,856.89</u>

THE OHIO STATE UNIVERSITY DEVELOPMENT FUND

Establishment of Named Designated Professorship

The Charles R. Webb
Designated Professorship in Finance

The Charles R. Webb Designated Professorship in Finance was established February 7, 2003, by the Board of Trustees of The Ohio State University with a gift from Charles R. Webb. Mr. Webb agrees to support The Max M. Fisher College of Business in the amount of \$187,500.00. These funds will be directed toward The Charles R. Webb Designated Professorship in Finance at the Fisher College of Business.

The gift shall be used to support a faculty member in the Department of Finance at the Fisher College of Business. The selection of The Charles R. Webb Designated Professorship will be determined by the Dean of the Fisher College of Business in consultation with the donor.

REPORT ON UNIVERSITY DEVELOPMENT (contd)

THE OHIO STATE UNIVERSITY DEVELOPMENT FUND (contd)

Establishment of Named Designated Professorship (contd)

The Charles R. Webb
Designated Professorship in Finance (contd)

It is the desire of the donor that this professorship be designated for five years. Should the professorship become vacant after initial selection, the Dean will identify another use for the gift in consultation with the donor. The gift will be completed in the following manner: cash in hand -- \$75,000; and proceeds from trust maturing in 12/2004 -- \$112,500.00.

\$75,000.00

Establishment of Named Endowed Funds

Katherine Miles Durst and Richard E. Durst Scholarship Fund for Psychology

The Katherine Miles Durst and Richard E. Durst Scholarship Fund for Psychology was established February 7, 2003, by the Board of Trustees of The Ohio State University with a gift from Katherine Miles Durst (B.A. with distinction, 1925; B.S.Ed., 1925; M.A., 1927) and Dr. Richard E. Durst (Ph.D., 1948).

All gifts are to be invested in the University's Permanent Endowment Fund, under the rules and regulations adopted by the Board of Trustees of The Ohio State University, with the right to invest and reinvest as occasion dictates.

The annual income shall be used to support one Merit Scholar at the medalist level and, if income allows, one University Scholar, as determined by the Honors and Scholars Program. The Katherine Miles Durst and Richard E. Durst Scholarship Fund for Psychology will fund scholars each year for four years so long as the required grade point average is maintained. The Durst Fund is restricted to students enrolled in the Department of Psychology in the Colleges of the Arts and Sciences. The fund will be administered by University Honors and Scholars in consultation with the University Committee on Student Financial Aid.

It is the desire of the donors that this fund should benefit the University in perpetuity. If the need for this fund should cease to exist or so diminish as to provide unused income, then another use shall be designated by the Board of Trustees in consultation with the associate provost for Honors and Scholars in the Office of Academic Affairs and the Department of Psychology in the Colleges of the Arts and Sciences in order to carry out the desire of the donors.

\$124,435.00

The Kaushalya Chawla Program Fund for
Geriatrics Care and Alzheimer's Disease Research in Pharmacy

The Kaushalya Chawla Program Fund for Geriatrics Care and Alzheimer's Disease Research in Pharmacy was established February 7, 2003, by the Board of Trustees of The Ohio State University with gifts from Mr. Ash Chawla (B.S.Pharm., 1981; M.S., 1983) and Mr. Chawla's family, friends, OSU pharmacy alumni, and business associates.

Mr. Chawla is an alumnus of The Ohio State University College of Pharmacy, having obtained both his Masters of Science degree in pharmacy and his Bachelors of Science in Pharmacy degree from the College. Mr. Chawla has always been very grateful and appreciative of the education, training, and guidance he received while at the College, most especially from his mentor and program advisor Dr. Milap Nahata.

REPORT ON UNIVERSITY DEVELOPMENT (contd)

THE OHIO STATE UNIVERSITY DEVELOPMENT FUND (contd)

Establishment of Named Endowed Funds (contd)

The Kaushalya Chawla Program Fund for
Geriatrics Care and Alzheimer's Disease Research in Pharmacy (contd)

Building on the education he received from the College, Mr. Chawla has become successful and a leader in the healthcare industry. It is Mr. Chawla's wish and desire to share his good fortune with the place it originated; he has therefore created this program fund at the College and provided the seed money to implement it. Mr. Chawla establishes this program fund in honor of his late mother, Mrs. Kaushalya Chawla, who passed away in October 2001, after a long battle with Alzheimer's disease.

All gifts are to be invested in the University's Permanent Endowment Fund, under the rules and regulations adopted by the Board of Trustees of The Ohio State University, with the right to invest and reinvest as occasion dictates.

The annual income shall be used for geriatrics and Alzheimer's disease research as designated by the director of the Division of Pharmacy Practice and Administration after consultation with Mr. Chawla.

It is the desire of the donors that this fund should benefit the University in perpetuity. If the need for this fund should cease to exist or so diminish as to provide unused income, then another use shall be designated by the Board of Trustees in consultation with the dean of the College of Pharmacy or his designee in order to carry out the desire of the donors.

\$67,876.00

Dr. Beverly Baer Endowed Scholarship Fund for Arts Education

The Dr. Beverly Baer Endowed Scholarship Fund for Arts Education was established February 7, 2003, by the Board of Trustees of The Ohio State University with gifts from William D. Baer of Columbus, Ohio, and Thomas N. Baer of Columbus, Ohio.

All gifts are to be invested in the University's Permanent Endowment Fund, under the rules and regulations adopted by the Board of Trustees of The Ohio State University, with the right to invest and reinvest as occasion dictates.

The annual income shall be used to provide a scholarship to a student majoring in Arts Education in the College of the Arts. The first preference shall be given to a female student majoring in Arts Education who is permanently disabled. The recipient will be chosen by the College of the Arts Undergraduate/Licensure Committee in consultation with the University Committee on Student Financial Aid. It is the donors' preference that this scholarship be awarded to an American citizen and that this student demonstrates a strong social consciousness for the application and utilization of art for the betterment of society. The second preference is that the scholarship be awarded to a student deemed eligible by the College of the Arts Undergraduate/Licensure Committee or the Graduate Committee in consultation with the Office of Student Financial Aid.

It is the desire of the donors that this fund should benefit the University in perpetuity. If the need for this fund should cease to exist or so diminish as to provide unused income, then another use shall be designated by the Board of Trustees in consultation with the College of the Arts, the University Committee on Student Financial Aid, and University Development in order to carry out the desire of the donors.

\$25,000.00

REPORT ON UNIVERSITY DEVELOPMENT (contd)

THE OHIO STATE UNIVERSITY DEVELOPMENT FUND (contd)

Change in Name of Named Endowed Fund

The Alumni Club of Orange County and Inland Empire Scholarship Fund

The Alumni Club of Orange County and Long Beach Scholarship Fund was established June 12, 1980, by the Board of Trustees of The Ohio State University with gifts from the Ohio State Alumni Club of Orange County and Long Beach, California. Per the Club's request, the name was revised on February 7, 2003.

All gifts are to be invested in the University's Permanent Endowment Fund, under the rules and regulations adopted by the Board of Trustees of The Ohio State University, with the right to invest and reinvest as occasion dictates.

The annual income shall be used to provide one or more scholarships for undergraduate or graduate students who have demonstrated academic ability and/or need for financial assistance, with preference being given to qualified California residents. The selection of the recipient is to be made upon the recommendation of the University Committee on Student Financial Aid and the University Scholarship Committee.

It is the desire of the donors that this fund should benefit the University in perpetuity. If the need for this fund should cease to exist or so diminish as to provide unused income, then another use shall be designated by the Board of Trustees in consultation with the appropriate administrative official of the University who is then directly responsible for student financial aid in order to carry out the desire of the donors.

Change in Name and Description of Named Endowed Fund

The John H. Moore Grant and Scholarship Fund

The John H. Moore Memorial Loan Fund was established on June 10, 1982, by the Board of Trustees of The Ohio State University with a gift from the estate of Ola K. Moore. The name and description were revised on February 7, 2003.

All gifts are to be invested in the University's Permanent Endowment Fund, under the rules and regulations adopted by the Board of Trustees of The Ohio State University, with the right to invest and reinvest as occasion dictates.

The annual income shall be used to fund scholarships and grants for students who attend The Ohio State University Marion Campus. Preference shall be given to those students who intend to enter the fields of architecture, engineering or medicine, with architecture as the first preference. Students in all fields, however, are eligible. Scholarships will be awarded in consultation with the University Committee on Student Financial Aid.

It is the desire of the donor that this fund should benefit The Ohio State University at Marion in perpetuity. If the need for this fund should cease to exist or so diminish as to provide unused income, then another use shall be designated by the Board of Trustees as recommended by the dean/director of The Ohio State University at Marion, in consultation with the Ohio State Marion Scholarship Committee, in order to carry out the desire of the donor.

REPORT ON UNIVERSITY DEVELOPMENT (contd)

THE OHIO STATE UNIVERSITY FOUNDATION

Establishment of Named Endowed Professorship

The Edwin D. Dodd Professorship in Management

The Edwin D. Dodd Professorship in Management was established February 7, 2003, in accordance with the guidelines approved by the Board of Directors of The Ohio State University Foundation, with a gift from the Edwin D. Dodd Fund at Charities Foundation.

All gifts are to be invested by the Foundation, under the rules and regulations adopted by the Foundation's Board of Directors, with the right to invest and reinvest as occasion dictates.

The annual income shall be used for an endowed professorship called "The Edwin D. Dodd Professorship in Management," at The Ohio State University Max M. Fisher College of Business. The endowment income will go toward compensation and support of a faculty member in the Fisher College of Business.

It is the desire of the donor that this fund should benefit the University in perpetuity. If the need for this fund should cease to exist or so diminish as to provide unused income, then another use shall be designated by the Foundation Board in consultation with the appropriate college dean, school director, department chairperson, or program administrative officer in order to carry out the desire of the donor.

\$750,000.00

Establishment of Named Endowed Funds

The Dr. Harold E. "Hal" and Faith B. Barlow Dental Scholarship Fund

The Dr. Harold E. "Hal" and Faith B. Barlow Dental Scholarship Fund was established February 7, 2003, in accordance with the guidelines approved by the Board of Directors of The Ohio State University Foundation, with gifts from the estate of Harold E. Barlow (B.A., 1936; D.D.S., 1939).

All gifts are to be invested by the Foundation, under the rules and regulations adopted by the Foundation's Board of Directors, with the right to invest and reinvest as occasion dictates.

The annual income shall be used to provide scholarships for dental students who have demonstrated outstanding academic achievements and/or participated in the College of Dentistry's student research programs. Selection of the recipients will be made by the dean of the College of Dentistry in consultation with the University Committee on Student Financial Aid.

It is the desire of the donor that this fund should benefit the University in perpetuity. If the need for this fund should cease to exist or so diminish as to provide unused income, then another use shall be designated by the Foundation Board in consultation with the dean of the College of Dentistry in order to carry out the desire of the donor.

\$313,907.00

The Aida Cannarsa Snow Endowment Fund
in the College of the Arts

The Aida Cannarsa Snow Endowment Fund in the College of the Arts was established February 7, 2003, in accordance with the guidelines approved by the Board of Directors of The Ohio State University Foundation with gifts from the estate of Aida Cannarsa Snow, Great Neck, New York.

REPORT ON UNIVERSITY DEVELOPMENT (contd)

THE OHIO STATE UNIVERSITY FOUNDATION (contd)

Establishment of Named Endowed Funds (contd)

The Aida Cannarsa Snow Endowment Fund
in the College of the Arts (contd)

All gifts are to be invested by the Foundation, under the rules and regulations adopted by the Foundation's Board of Directors, with the right to invest and reinvest as occasion dictates.

The annual income shall be used to provide tuition scholarship awards to undergraduate and graduate students enrolled in the College of the Arts with a major or specialized interest in the Departments of Art, Art Education, History of Art, Theatre or Dance.

The dean of the College of the Arts and/or his/her representative shall have responsibility for the selection of award recipients in consultation with the University Committee on Student Financial Aid. All such awards shall be based on financial need.

In any given year that the income is not fully expended, the unused portion should be reinvested in the principal.

It is the desire of the donor that this fund should benefit the University in perpetuity. If the need for this fund should cease to exist or so diminish as to provide unused income, then another use shall be designated by the Foundation Board in consultation with the dean of the College of the Arts and/or his/her representative in order to carry out the desire of the donor.

\$208,333.34

The William M. and Darlene Aldrige Music Scholarship Fund

The William M. and Darlene Aldrige Music Scholarship Fund was established February 7, 2003, in accordance with the guidelines approved by the Board of Directors of The Ohio State University Foundation, with gifts from the estate of Darlene Aldrige of Hillsboro, Ohio, and in memory of her husband, William M. Aldrige (B.S.Agr., 1961).

All gifts are to be invested by the Foundation, under the rules and regulations adopted by the Foundation's Board of Directors, with the right to invest and reinvest as occasion dictates.

The annual income shall be used to support scholarships for students enrolled in the School of Music. The student recipients must exhibit high moral standards, reside in Highland County, Ohio, and have graduated from a high school in Highland County, Ohio. Scholarships will be awarded in consultation with the University Committee on Student Financial Aid.

In any given year that the income is not fully expended, the unused portion should be reinvested in the principal.

It is the desire of the donor that this fund should benefit the University in perpetuity. If the need for this fund should cease to exist or so diminish as to provide unused income, then another use shall be designated by the Foundation Board in consultation with the director of the School of Music in order to carry out the desire of the donor.

\$150,000.00

REPORT ON UNIVERSITY DEVELOPMENT (contd)

THE OHIO STATE UNIVERSITY FOUNDATION (contd)

Establishment of Named Endowed Funds (contd)

The Harold A. McIntosh Fund

The Harold A. McIntosh Fund was established February 7, 2003, in accordance with the guidelines approved by the Board of Directors of The Ohio State University Foundation, with gifts from the estate of Harold A. "Marc" McIntosh (B.F.A., 1966).

All gifts are to be invested by the Foundation, under the rules and regulations adopted by the Foundation's Board of Directors, with the right to invest and reinvest as occasion dictates.

The intention of the estate is that the funds will be used for scholarships for gay, lesbian, and bisexual students at The Ohio State University. The Gay, Lesbian, Bisexual, and Transgender Alumni Society (part of the Alumni Association) will be the administrator for these funds and will coordinate distribution of the scholarship. The Office of Student Affairs - Student Gender and Sexuality Services, and Student Financial Aid will both serve as partners in the administration of the scholarship. Both University offices will actively market the availability of the scholarship to students throughout the year with a special emphasis during Winter Quarter so scholarships may be awarded in the spring for the following academic year.

It is anticipated that five scholarships will be awarded per year with one being dedicated to a person living with AIDS or HIV and another being dedicated to persons who have volunteered to work for AIDS-related causes. The remainder would be general scholarships for the GLBT community.

The estate of Harold A. "Marc" McIntosh shall be given information annually at the conclusion of Spring Quarter by providing to the estate representative, Charles R. Rice, during his life, a summary of the marketing activities and the scholarships awarded from the endowment fund.

The Gay, Lesbian, Bisexual, and Transgender Alumni Society will market the availability of the scholarships through campus media, University offices, local and state GLBT media, and with visits to GLBT student organizations. A selections committee made up of GLBT Alumni Society members, local community leaders, University faculty and staff, and representatives of Parents and Friends of Lesbians and Gays (PFLAG) will make decisions on award of the scholarships. Scholarship recipients will be recognized in local, state, and national (as applicable) media. Notification will also be made to The Ohio State University Alumni Association, The Ohio State University Office of Student Financial Aid, and the McIntosh estate.

Any income remaining at the end of the fiscal year should be reinvested into the principal.

It is the desire of the donor that this fund should benefit the University in perpetuity. If the need for this fund should cease to exist or so diminish as to provide unused income, then another use shall be designated by the Foundation Board as recommended by the President of The Gay, Lesbian, Bisexual, and Transgender Alumni Society in order to carry out the desire of the donor. Any alternative use will be in conjunction with the original purpose of the gift.

\$134,787.00

The Dr. Clyde D. Gump Pediatric Dentistry Fund

The Dr. Clyde D. Gump Pediatric Dentistry Fund was established February 7, 2003, in accordance with the guidelines approved by the Board of Directors of The Ohio State University Foundation, with gifts from the estate of Julia Robert Gump (B.S.Ed., 1940; M.A., 1954) in memory of Clyde D. Gump (D.D.S., 1941).

REPORT ON UNIVERSITY DEVELOPMENT (contd)

THE OHIO STATE UNIVERSITY FOUNDATION (contd)

Establishment of Named Endowed Funds (contd)

The Dr. Clyde D. Gump Pediatric Dentistry Fund (contd)

All gifts are to be invested by the Foundation, under the rules and regulations adopted by the Foundation's Board of Directors, with the right to invest and reinvest as occasion dictates.

The intended use of this fund is at the sole discretion of the head of the Section of Pediatric Dentistry in The Ohio State University College of Dentistry, and can include equipment purchase or repair, facility renovation or repair, and student and faculty awards. It is the intent of the donor that the annual income be used by the head of the Section of Pediatric Dentistry without restrictions.

It is the desire of the donor that this fund should benefit the University in perpetuity. If the need for this fund should cease to exist or so diminish as to provide unused income, then another use shall be designated by the Foundation Board in consultation with the head of the Section of Pediatric Dentistry in the College of Dentistry in order to carry out the desire of the donor.

\$110,475.22

The Robert and Mary Reusche Scholarships for Study Abroad Fund

The Robert and Mary Reusche Scholarships for Study Abroad Fund in the College of Humanities was established February 7, 2003, in accordance with the guidelines approved by the Board of Directors of The Ohio State University Foundation, with gifts from Robert (B.S.Bus.Adm., 1949) and Mary (B.S.Bus.Adm., 1950) Reusche.

All gifts are to be invested by the Foundation, under the rules and regulations adopted by the Foundation's Board of Directors, with the right to invest and reinvest as occasion dictates.

The annual income shall be awarded as study abroad scholarships to third-year scholars who reside in the south campus Humanities Scholars dorm during their second year of study, and who participated in thematic programs in preparation for the following year's study abroad experience. Second-year scholars who reside in this dorm during the 2003-2004 academic year will be eligible for the first year of these awards in the 2004-2005 academic year.

If in any one year the funds available for the above outlined study abroad scholarship exceeds the number of students available, the additional funds will be used for merit scholarships for new freshmen Humanities Scholars students. Scholarships will be awarded in consultation with the University Committee on Student Financial Aid.

It is the desire of the donors that this fund should benefit the University in perpetuity. If the need for this fund should cease to exist or so diminish as to provide unused income, then another use shall be designated by the Foundation Board as recommended by the dean of the College of Humanities in order to carry out the desire of the donors.

\$100,000.00

The Jimmy Warfield Athletic Training Scholarship Fund

The Jimmy Warfield Athletic Training Scholarship Fund was established February 7, 2003, in accordance with the guidelines approved by the Board of Directors of The Ohio State University Foundation, with gifts from Linda Warfield of Hudson, Ohio, and the Cleveland Indians Charities.

REPORT ON UNIVERSITY DEVELOPMENT (contd)

THE OHIO STATE UNIVERSITY FOUNDATION (contd)

Establishment of Named Endowed Funds (contd)

The Jimmy Warfield Athletic Training Scholarship Fund (contd)

All gifts are to be invested by the Foundation, under the rules and regulations adopted by the Foundation's Board of Directors, with the right to invest and reinvest as occasion dictates.

The annual income shall be used to supplement the student grant-in-aid scholarship costs of athletic training students enrolled in the Athletic Training program who are pursuing an undergraduate degree at The Ohio State University. The director of Athletics will select recipients in consultation with the director of Athletic Training program and the University Committee on Student Financial Aid.

It is the desire of the donors that this fund should benefit the University in perpetuity. If the need for this fund should cease to exist or so diminish as to provide unused income, then another use shall be designated by the Foundation Board as recommended by the director of Athletics in order to carry out the desire of the donors.

\$55,000.00

The COBA/Select Sires Dairy Industry Enhancement Endowment Fund

The COBA/Select Sires Dairy Industry Enhancement Endowment Fund was established February 7, 2003, in accordance with the guidelines approved by the Board of Directors of The Ohio State University Foundation, with a gift from COBA/Select Sires.

All gifts are to be invested by the Foundation, under the rules and regulations adopted by the Foundation's Board of Directors, with the right to invest and reinvest as occasion dictates.

The annual income shall be used to support an extension associate for dairy industry enhancement in the Department of Animal Sciences in the College of Food, Agricultural, and Environmental Sciences. If the income cannot be used as specified, the donor requests that the following uses be considered in priority order as listed: 1) dairy student scholarship at the OSU main campus; 2) dairy student scholarship at the OSU-ATI Wooster campus; and 3) support of dairy research at the OSU-OARDC Wooster campus.

It is the desire of the donor that this fund should benefit the University in perpetuity. If the need for this fund should cease to exist or so diminish as to provide unused income, then another use shall be designated by the Foundation Board in consultation with the vice president for Agricultural Administration and University Outreach, and executive dean for Food, Agricultural, and Environmental Sciences, and the chairperson of the Department of Animal Sciences or their successors in order to carry out the desire of the donor.

\$50,000.00

College of Dentistry Endowed Chair Fund in Endodontics

The College of Dentistry Endowed Chair Fund in Endodontics was established February 7, 2003, in accordance with the guidelines approved by the Board of Directors of The Ohio State University Foundation, with gifts from Joseph A. Haase, (D.D.S., 1969) of Worthington, Ohio; alumni, faculty and friends.

REPORT ON UNIVERSITY DEVELOPMENT (contd)

THE OHIO STATE UNIVERSITY FOUNDATION (contd)

Establishment of Named Endowed Funds (contd)

College of Dentistry Endowed Chair Fund in Endodontics (contd)

All gifts are to be invested by the Foundation, under the rules and regulations adopted by the Foundation's Board of Directors, with the right to invest and reinvest as occasion dictates.

The annual income shall be added to the principal until the minimum amount for funding an endowed chair has been reached. At that time, the annual income shall be used to provide salary and program support to a distinguished faculty member in the Section of Endodontics in the College of Dentistry. Selection of the named chair holder shall be made in consultation with the senior vice president for Health Sciences and dean of the College of Medicine and Public Health and the dean of the College of Dentistry with recommendation from the head of the Section of Endodontics.

It is the desire of the donors that this fund should benefit the University in perpetuity. If the need for this fund should cease to exist or so diminish as to provide unused income, then another use shall be designated by the Foundation Board in consultation with the head of the Section of Endodontics and the dean of the College of Dentistry in order to carry out the desire of the donors.

\$47,500.00

The Aida Cannarsa Snow Endowment Fund
in the Colleges of the Arts and Sciences

The Aida Cannarsa Snow Endowment Fund in the Colleges of the Arts and Sciences was established February 7, 2003, in accordance with the guidelines approved by the Board of Directors of The Ohio State University Foundation, with gifts from the estate of Aida Cannarsa Snow of Great Neck, New York.

All gifts are to be invested by the Foundation, under the rules and regulations adopted by the Foundation's Board of Directors, with the right to invest and reinvest as occasion dictates.

The annual income shall be used to provide tuition scholarship awards to undergraduate and graduate students enrolled in the Colleges of the Arts and Sciences who are pursuing a career in publishing or publications.

The executive dean of the Colleges of the Arts and Sciences and/or his/her representative shall have responsibility for the selection of award recipients in consultation with the University Committee on Student Financial Aid. All such awards shall be based on financial need.

In any given year that the income is not fully expended, the unused portion should be reinvested in the principal.

It is the desire of the donor that this fund should benefit the University in perpetuity. If the need for this fund should cease to exist or so diminish as to provide unused income, then another use shall be designated by the Foundation Board in consultation with the executive dean of the Colleges of the Arts and Sciences and/or his/her representative in order to carry out the desire of the donor.

\$41,666.66

REPORT ON UNIVERSITY DEVELOPMENT (contd)

THE OHIO STATE UNIVERSITY FOUNDATION (contd)

Establishment of Named Endowed Funds (contd)

The Edmund M. Kagay Scholarship Fund

The Edmund M. Kagay Scholarship Fund was established February 7, 2003, in accordance with the guidelines approved by the Board of Directors of The Ohio State University Foundation, with a gift from the estate of Edmund M. Kagay of Columbus, Ohio.

All gifts are to be invested by the Foundation, under the rules and regulations adopted by the Foundation's Board of Directors, with the right to invest and reinvest as occasion dictates.

The annual income shall be used to support merit-based language study abroad scholarships within the College of Humanities. Scholarships will be awarded in consultation with the University Committee on Student Financial Aid.

It is the desire of the donor that this fund should benefit the University in perpetuity. If the need for this fund should cease to exist or so diminish as to provide unused income, then another use shall be designated by the Foundation Board in consultation with the dean of the College of Humanities in order to carry out the desire of the donor.

\$40,337.12

Wexner Center Education Endowment Fund

The Wexner Center Education Endowment Fund was established February 7, 2003, in accordance with the guidelines approved by the Board of Directors of The Ohio State University Foundation, with a gift from an anonymous donor.

Subject to the approval of the Board of Trustees of the University, the donor may rename the Endowment during her lifetime through an instrument in writing delivered to the University, or at her death through a provision in her Last Will and Testament as certified to the University by her executor.

All gifts are to be invested by the Foundation, under the rules and regulations adopted by the Foundation's Board of Directors, with the right to invest and reinvest as occasion dictates.

The annual income shall be used exclusively to support the Wexner Center's education programs fostering an environment of inquiry, discovery, and learning for audiences of all ages, interests, and backgrounds with preferences given to programs for teachers and schools, programs for children and families, and programs for adults.

It is the desire of the donor that this fund should benefit the University in perpetuity. If the need for this fund should cease to exist or so diminish as to provide unused income, then another use shall be designated by the Foundation Board in consultation with the Wexner Center's director and director of the Wexner Center's education programs in order to carry out the desire of the donor.

\$40,000.00

The Donald E. and Martha L. Fogg Alpha Tau Zeta Scholarship Fund

The Donald E. and Martha L. Fogg Alpha Tau Zeta Scholarship Fund was established February 7, 2003, in accordance with the guidelines approved by the Board of Directors of The Ohio State University Foundation, with gifts from Donald E. Fogg (B.S.Agr., 1949) and Martha L. Fogg (B.S.H.E., 1949).

REPORT ON UNIVERSITY DEVELOPMENT (contd)

THE OHIO STATE UNIVERSITY FOUNDATION (contd)

Establishment of Named Endowed Funds (contd)

The Donald E. and Martha L. Fogg Alpha Tau Zeta Scholarship Fund (contd)

All gifts are to be invested by the Foundation, under the rules and regulations adopted by the Foundation's Board of Directors, with the right to invest and reinvest as occasion dictates.

The annual income shall be used for scholarship(s) for sophomore, junior, or senior students enrolled in the College of Food, Agricultural, and Environmental Sciences who are members of the Alpha Tau Zeta Fraternity. The student(s) must hold at least a 3.0 grade point average. Any recipient(s) must be living in the Alpha Tau Zeta fraternity house at the time of receipt of the scholarship and, in addition, must have been living there the past two quarters or semesters (if applicable) while enrolled in The Ohio State University. Selection of the recipient(s) will be made by the assistant dean of Student Affairs in the College of Food, Agricultural, and Environmental Sciences and the scholarship selection committee in conjunction with the University Committee on Student Financial Aid.

It is the desire of the donors that this fund should benefit the University in perpetuity. If the need for this fund should cease to exist or so diminish as to provide unused income, then another use shall be designated by the Foundation Board in consultation with the vice president for Agricultural Administration and University Outreach, and executive dean for Food, Agricultural, and Environmental Sciences or the appropriate college dean, department chair, or program administrative officer in order to carry out the desire of the donors.

\$39,357.30

The Unverferth House Endowment Fund

The Unverferth House Endowment Fund was established February 7, 2003, in accordance with the guidelines approved by the Board of Directors of The Ohio State University Foundation with gifts to The Ohio State University Foundation from friends of the Unverferth House.

All gifts are to be invested by the Foundation, under the rules and regulations adopted by the Foundation's Board of Directors, with the right to invest and reinvest as occasion dictates.

The annual income shall be used to support purchases of equipment, building maintenance costs, and all general operating costs of The Unverferth House. In any given year that the income is not fully expended, the unused portion should be reinvested in the principal.

It is the desire of the donor that this fund should benefit the University in perpetuity. If the need for this fund should cease to exist or so diminish as to provide unused income, then another use shall be designated by the Foundation Board in consultation with the appropriate college dean, department chairperson, or program administrative officer in order to carry out the desire of the donor.

\$25,611.25

The Robinson Craig Fendrick - Gwynne Conservation Fund

The Robinson Craig Fendrick - Gwynne Conservation Fund was established February 7, 2003, in accordance with the guidelines approved by the Board of Directors of The Ohio State University Foundation in memory of Robinson Craig Fendrick, with gifts from the Farm Science Review Alumni Association and the Gwynne Conservation Area Committee in cooperation with members of "Baby Craig's" family and friends.

REPORT ON UNIVERSITY DEVELOPMENT (contd)

THE OHIO STATE UNIVERSITY FOUNDATION (contd)

Establishment of Named Endowed Funds (contd)

The Robinson Craig Fendrick - Gwynne Conservation Fund (contd)

All gifts are to be invested by the Foundation, under the rules and regulations adopted by the Foundation's Board of Directors, with the right to invest and reinvest as occasion dictates.

The annual income shall be used to support educational programs and their maintenance, for the Gwynne Conservation Area at the Molly Caren Agricultural Center.

The use of the annual income shall be directed by the manager of The Ohio State University Farm Science Review or their designee.

It is the desire of the donors that this fund should benefit the University in perpetuity. If the need for this fund should cease to exist or so diminish as to provide unused income, then another use shall be designated by the Foundation Board in consultation with the vice president for Agricultural Administration and University Outreach, and executive dean for Food, Agricultural, and Environmental Sciences, in consultation with the manager of The Ohio State University Farm Science Review or their successor, or appropriate administrative officer, or their successor, in order to carry out the desire of the donors.

\$25,571.00

The BBK&C Athletic Scholarship Fund

The BBK&C Athletic Scholarship Fund was established February 7, 2003, in accordance with the guidelines approved by the Board of Directors of The Ohio State University Foundation, with gifts from Mr. John V. Johnson II of Westerville, Ohio.

All gifts are to be invested by the Foundation, under the rules and regulations adopted by the Foundation's Board of Directors, with the right to invest and reinvest as occasion dictates.

The annual income shall be used to supplement the grant-in-aid scholarship costs of a scholar-athlete who is a member of the varsity football team pursuing an undergraduate degree at The Ohio State University. Recipients shall be selected by the director of Athletics in consultation with the University Committee on Student Financial Aid.

It is the desire of the donor that this fund should benefit the University in perpetuity. If the need for this fund should cease to exist or so diminish as to provide unused income, then another use shall be designated by the Foundation Board as recommended by the director of Athletics in order to carry out the desire of the donor.

\$25,000.00

The Harry T. Mangurian, Jr. MBA Fellowship Fund

The Harry T. Mangurian, Jr. MBA Fellowship Fund was established February 7, 2003, in accordance with the guidelines approved by the Board of Directors of The Ohio State University Foundation, with a gift from The Mangurian Foundation, Inc.

All gifts are to be invested by the Foundation, under the rules and regulations adopted by the Foundation's Board of Directors, with the right to invest and reinvest as occasion dictates.

REPORT ON UNIVERSITY DEVELOPMENT (contd)

THE OHIO STATE UNIVERSITY FOUNDATION (contd)

Establishment of Named Endowed Funds (contd)

The Harry T. Mangurian, Jr. MBA Fellowship Fund (contd)

The annual income shall be used to provide support to a graduate student(s) in The Max M. Fisher College of Business. Selection of the recipient(s) shall be made by the Fisher College graduate programs director.

It is the desire of the donor that this fund should benefit the University in perpetuity. If the need for this fund should cease to exist or so diminish as to provide unused income, then another use shall be designated by the Foundation Board as recommended by the person or unit with spending authority, and/or appropriate University official in order to carry out the desire of the donor.

\$25,000.00

The Bonna "Sue" and Louis "Clem" Margulis
Endowment Fund for Cancer Research

The Bonna "Sue" and Louis "Clem" Margulis Endowment Fund for Cancer Research at the Comprehensive Cancer Center – The Arthur G. James Cancer Hospital and Richard J. Solove Research Institute was established February 7, 2003, in accordance with the guidelines approved by the Board of Directors of The Ohio State University Foundation, with a gift from the estate of Bonna "Sue" Margulis of Columbus, Ohio.

All gifts are to be invested by the Foundation, under the rules and regulations adopted by the Foundation's Board of Directors, with the right to invest and reinvest as occasion dictates.

The annual income shall be used to support cancer research with preference given to population sciences, at the Comprehensive Cancer Center – The Arthur G. James Cancer Hospital and Richard J. Solove Research Institute at The Ohio State University as approved by the director of The Arthur G. James Cancer Hospital and Richard J. Solove Research Institute, the director of the Comprehensive Cancer Center, and the senior vice president for Health Sciences and dean of the College of Medicine and Public Health.

It is the desire of the donor that this fund should benefit the University in perpetuity. If the need for this fund should cease to exist or so diminish as to provide unused income, then another use shall be designated by the Foundation Board in consultation with the director of The Arthur G. James Cancer Hospital and Richard J. Solove Research Institute, the director of the Comprehensive Cancer Center, and the senior vice president for Health Sciences and dean of the College of Medicine and Public Health in order to carry out the desire of the donor.

\$25,000.00

The Dr. Arlene Marx and Dr. Larry Mundy Athletic Scholarship Fund

The Dr. Arlene Marx and Dr. Larry Mundy Athletic Scholarship Fund was established February 7, 2003, in accordance with the guidelines approved by the Board of Directors of The Ohio State University Foundation, with gifts from Dr. Arlene Marx (B.S.Med.Tech., 1970) and Dr. Larry Mundy of Spring, Texas.

All gifts are to be invested by the Foundation, under the rules and regulations adopted by the Foundation's Board of Directors, with the right to invest and reinvest as occasion dictates.

REPORT ON UNIVERSITY DEVELOPMENT (contd)

THE OHIO STATE UNIVERSITY FOUNDATION (contd)

Establishment of Named Endowed Funds (contd)

The Dr. Arlene Marx and Dr. Larry Mundy Athletic Scholarship Fund (contd)

The annual income shall be used to provide scholarship costs of student athletes who are pursuing undergraduate degrees at The Ohio State University and participating on the varsity football team. Recipients shall be selected by the director of Athletics in consultation with the University Committee on Student Financial Aid and in accordance with the NCAA rules.

It is the desire of the donors that this fund should benefit the University in perpetuity. If the need for this fund should cease to exist or so diminish as to provide unused income, then another use shall be designated by the Foundation Board as recommended by the director of Athletics in order to carry out the desire of the donors.

\$25,000.00

The Paul A. and Betty L. Whittington Endowed Scholarship Fund

The Paul A. and Betty L. Whittington Endowed Scholarship Fund was established February 7, 2003, in accordance with the guidelines approved by the Board of Directors of The Ohio State University Foundation with gifts from Paul A. (B.S.Agr., 1971) and Betty L. Whittington, Sabina, OH.

All gifts are to be invested by the Foundation, under the rules and regulations adopted by the Foundation's Board of Directors, with the right to invest and reinvest as occasion dictates.

The annual income shall be used to support scholarships for undergraduate students, with a 2.50 GPA or above, enrolled in the College of Food, Agricultural, and Environmental Sciences. First preference is to student(s) who have graduated from East Clinton High School (Clinton County, Ohio). Preference is given to those with outstanding achievements who continue to lead and serve in the University community. If no student(s) are eligible from East Clinton High School then the second preference shall be given to student(s) from Clinton County, Ohio. Annual scholarship recipients shall be selected by the College Scholarship Committee in consultation with the University Committee on Student Financial Aid.

In any given year that the income is not fully expended, the unused portion should be reinvested in the principal.

It is the desire of the donors that this fund should benefit the University in perpetuity. If the need for this fund should cease to exist or so diminish as to provide unused income, then another use shall be designated by the Foundation Board, in consultation with the vice president for Agricultural Administration and University Outreach, and executive dean for Food, Agricultural, and Environmental Sciences or their successor, or an appropriate administrative officer, or their successor, in order to carry out the desire of the donors.

\$25,000.00

Change in Description of Named Endowed Funds

The William M. and Darlene Aldrige Agriculture Scholarship Fund

The William M. and Darlene Aldrige Agriculture Scholarship Fund was established on November 1, 2002 in accordance with the guidelines approved by the Board of Directors of The Ohio State University Foundation with gifts from the estate of Darlene Aldrige of Hillsboro, Ohio, and in memory of her husband, William M. Aldrige, (B.S.Agr., 1961). The description was revised on February 7, 2003.

REPORT ON UNIVERSITY DEVELOPMENT (contd)

THE OHIO STATE UNIVERSITY FOUNDATION (contd)

Change in Description of Named Endowed Funds (contd)

The William M. and Darlene Aldrige Agriculture Scholarship Fund (contd)

All gifts are to be invested by the Foundation, under the rules and regulations adopted by the Foundation's Board of Directors, with the right to invest and reinvest as occasion dictates.

The annual income shall be used to support scholarships for students enrolled in the College of Food, Agricultural, and Environmental Sciences including the Agricultural Technical Institute. The student recipients must exhibit high moral standards, reside in Highland County, Ohio, and have graduated from a high school in Highland County, Ohio.

Annual scholarship recipients shall be selected by the college scholarship selection committee in consultation with the University Committee on Student Financial Aid.

In any given year that the income is not fully expended, the unused portion should be reinvested in the principal.

It is the desire of the donor that this fund should benefit the University in perpetuity. If the need for this fund should cease to exist or so diminish as to provide unused income, then another use shall be designated by the Foundation Board in consultation with the vice president for Agricultural Administration and University Outreach, and executive dean for Food, Agricultural, and Environmental Sciences, or their successor, in order to carry out the desire of the donor.

The Evelyn Michael MBA Fellowship Fund

The Evelyn Michael MBA Fellowship Fund was established November 1, 2002, in accordance with the guidelines approved by the Board of Directors of The Ohio State University Foundation, with a gift from Timothy A. Michael (B.A., 1970; M.B.A., 1976) and Melinda Vogel Michael (B.S.Ed., cum laude, 1970; M.A., 1975). The description was revised on February 7, 2003.

All gifts are to be invested by the Foundation, under the rules and regulations adopted by the Foundation's Board of Directors, with the right to invest and reinvest as occasion dictates.

The annual income shall be used to provide support to a graduate student(s) in The Max M. Fisher College of Business. Selection of the recipient(s) shall be made by the Fisher College of Business graduate programs director with consideration given to a graduate student(s) who may add to the overall diversity of the college's graduate program. Special preference shall be given to minorities and/or candidates who have served in the United States military.

It is the desire of the donors that this fund should benefit the University in perpetuity. If the need for this fund should cease to exist or diminish as to provide unused income, then another use shall be designated by the Board of Trustees as recommended by the person or unit with spending authority, and/or appropriate University official, in order to carry out the desire of the donors.

WAIVERS OF COMPETITIVE BIDDING REQUIREMENTS

Resolution No. 2003-84

OCTOBER – DECEMBER 2002

Synopsis: Acceptance of the quarterly report on waivers of competitive bidding requirements is proposed.

WHEREAS the Purchasing Policy of The Ohio State University adopted by the Board of Trustees on September 7, 1984, and revised on February 7, 1992, July 8, 1994, November 7, 1997, and March 1, 2002 provides that the President and/or the Senior Vice President for Business and Finance, or for the Hospitals of the University and their related facilities, the Vice President for Health Services, may grant a waiver from competitive bidding in the event of an emergency, when a sufficient economic reason exists or when the goods or services can be purchased from only a single source, with a report on such waivers to be made quarterly to this Board; and

WHEREAS the Senior Vice President for Business and Finance has submitted a report on waivers of competitive bidding requirements granted for the period of October – December 2002; and

WHEREAS during the period covered, the Senior Vice President for Business and Finance, at the requests of the departments making the purchases and upon the recommendation of the Purchasing Department, granted 46 waivers of competitive bidding requirements for annual purchases totaling approximately \$5,356,500 as shown on the enclosed exhibit; and

WHEREAS during the period covered, the Vice President for Health Services, at the requests of the Hospitals of the University and their related facilities making purchases, granted 37 waivers of competitive bidding requirements for annual purchases totaling approximately \$11,855,700 as shown on the enclosed exhibit:

NOW THEREFORE

BE IT RESOLVED, That the report on waivers of competitive bidding requirements for the period of October - December 2002, is hereby accepted.

(See Appendix XXXIII for background information, page 757.)

**SECOND QUARTER BUDGET REPORT
FISCAL YEAR 2002-03**

Resolution No. 2003-85

Synopsis: The second quarter budget report for fiscal year 2002-03 is submitted for approval.

WHEREAS the University's enrollments for Summer, Autumn and Winter Quarters are now known, allowing for a more accurate picture of the University's student fee revenue; and

WHEREAS other revenues such as Indirect Cost Recoveries on sponsored programs have been projected higher than originally budgeted; and

WHEREAS appropriate planning and consultation within the University has been accomplished and the President now recommends approval of the second quarter budget report:

NOW THEREFORE

**SECOND QUARTER BUDGET REPORT
FISCAL YEAR 2002-03 (contd)**

BE IT RESOLVED, That the second quarter report for the FY 2002-03 budget be approved and that the appropriate resources and expenditure budgets be adjusted to reflect these changes as of the second quarter as described in the attached materials.

(See Appendix XXXIV for background information, page 759.)

**BUDGET VERSUS ACTUAL REPORT
FISCAL YEAR 2001-02**

Resolution No. 2003-86

Synopsis: The budget versus actual report for FY 2001-02 is submitted for approval.

WHEREAS the FY 2002 audit of the University's income and expenditures is now complete; and

WHEREAS the Current Funds Budget for FY 2002 has been compared to the audited income and expenditures for FY 2002 and any significant variances explained:

NOW THEREFORE

BE IT RESOLVED, That the budget versus actual report for FY 2001-02 be approved.

(See Appendix XXXV for background information, page 765.)

**EMPLOYMENT OF ARCHITECTS/ENGINEERS,
EMPLOYMENT OF CONSTRUCTION MANAGER,
REQUEST FOR CONSTRUCTION BIDS, AND
REPORT OF AWARD OF CONTRACTS**

Resolution No. 2003-87

MARION CAMPUS – STUDENT HOUSING
LIMA CAMPUS – STUDENT HOUSING
MARION CAMPUS – STUDENT SERVICES BUILDING
VETERINARY HOSPITAL – STUDENT LOUNGE RENOVATION
AIRPORT PAVEMENT REHABILITATION/EXTENSION – PHASE I
SOFTBALL STADIUM SPORTS LIGHTING
CAMPBELL HALL, UNIVERSITY HALL, AND EVANS LAB RENOVATION
LIMA CAMPUS – REED HALL THEATRE ADDITION
STARLING-LOVING HALL – BIOSTATISTICS
JOB ORDER CONTRACT 2003
650 ACKERMAN ROAD – RENOVATION
WOODY HAYES ATHLETIC FACILITY – TURF REPLACEMENT
FOOTBALL PRACTICE FIELD #4 – TURF INSTALLATION
ATI – SHISLER CENTER COURTYARD
BEVIS HALL ROOF REPLACEMENT
BOLZ HALL – ROOF REPLACEMENT
BYRD POLAR RESEARCH CENTER – ROCK REPOSITORY
CAMPUS GROUNDS – NEIL AVENUE STREET REBUILD
CELESTE LABORATORY HVAC MODIFICATIONS
CENTRAL CHILLED WATER LOOP 17TH AVENUE TO DERBY HALL
COCKINS HALL – MATH/STATISTICS LEARNING LAB

**EMPLOYMENT OF ARCHITECTS/ENGINEERS,
EMPLOYMENT OF CONSTRUCTION MANAGER,
REQUEST FOR CONSTRUCTION BIDS, AND
REPORT OF AWARD OF CONTRACTS (contd)**

DODD HALL – CHILLED WATER PLANT STRUCTURE
EVANS LAB – ROOF REPLACEMENT
GOLF COURSE – MEN'S LOCKER ROOM RENOVATION
GOSS LAB – WINDOW REPLACEMENT
GRAVES HALL HVAC SYSTEM UPGRADES
GRAVES HALL ROOF REPLACEMENT
HAYES HALL ROOF REPLACEMENT
KOFFOLT AND FONTANA LABS ROOF REPLACEMENT
LIMA CAMPUS – 15KV OIL SWITCH REPLACEMENT
MANSFIELD CAMPUS – ROADWAY AND PARKING LOT RESURFACING
MIRROR LAKE HOLLOW RENOVATION
MULTI-PURPOSE TURF FIELD
OARNET – HVAC AND ELECTRICAL IMPROVEMENTS
ORTON HALL ROOF REPLACEMENT
PAGE HALL RENOVATION
PARKER FOOD SCIENCE – PILOT PLANT FACILITY
PHYSICAL SCIENCES RESEARCH BUILDING
POSTLE HALL – ORAL AND MAXILLOFACIAL SURGERY
RIVERWATCH TOWER – SUITES B AND C
STARLING-LOVING HALL RENOVATION
UNIVERSITY HOSPITAL/RHODES HALL ENTRANCE
WISEMAN HALL – COMPREHENSIVE CANCER CENTER
WOMEN'S FIELD HOUSE RELOCATION

Synopsis: Authorization to employ architect/engineering firms for the Marion Campus – Student Housing, Lima Campus – Student Housing, Marion Campus – Student Services Building, Airport Pavement Rehabilitation/Extension – Phase I, 650 Ackerman Road – Renovation, Woody Hayes Athletic Facility – Turf Replacement, and Football Practice Field #4 – Turf Installation projects, employ construction managers for the Marion Campus – Student Housing and Lima Campus – Student Housing projects, request construction bids for the Veterinary Hospital – Student Lounge Renovation, Softball Stadium Sports Lighting, Campbell Hall, University Hall, and Evans Lab Renovation, Lima Campus – Reed Hall Theatre Addition, Starling-Loving Hall – Biostatistics, and Job Order Contract 2003 projects, and acceptance of the report of award of contracts for ATI – Shisler Center Courtyard, Bevis Hall Roof Replacement, Bolz Hall – Roof Replacement, Byrd Polar Research Center – Rock Repository, Campus Grounds – Neil Avenue Street Rebuild, Celeste Laboratory HVAC Modifications, Central Chilled Water Loop 17TH Avenue to Derby Hall, Cockins Hall – Math/Statistics Learning Lab, Dodd Hall – Chilled Water Plant Structure, Evans Lab – Roof Replacement, Golf Course – Men's Locker Room Renovation, Goss Lab – Window Replacement, Graves Hall HVAC System Upgrades, Graves Hall Roof Replacement, Hayes Hall Roof Replacement, Koffolt and Fontana Labs Roof Replacement, Lima Campus – 15KV Oil Switch Replacement, Mansfield Campus – Roadway and Parking Lot Resurfacing, Mirror Lake Hollow Renovation, Multi-Purpose Turf Field, OARnet – HVAC and Electrical Improvements, Orton Hall Roof Replacement, Page Hall Renovation, Parker Food Science – Pilot Plant Facility, Physical Sciences Research Building, Postle Hall – Oral and Maxillofacial Surgery, Riverwatch Tower - Suites B and C, Starling-Loving Hall Renovation, University Hospital/Rhodes Hall Entrance, Wiseman Hall – Comprehensive Cancer Center, and Women's Field House projects is requested.

WHEREAS a resolution adopted by the Board of Trustees on November 2, 2001 authorized the employment of architect/engineer and construction manager firms for the Marion Campus – Student Housing project; and

WHEREAS following that authorization, a pro forma has been completed that indicates the number of beds to be included in the project should be increased from 160 to 300, resulting in a

**EMPLOYMENT OF ARCHITECTS/ENGINEERS,
EMPLOYMENT OF CONSTRUCTION MANAGER,
REQUEST FOR CONSTRUCTION BIDS, AND
REPORT OF AWARD OF CONTRACTS (contd)**

preliminary project cost increase from \$7,045,753 to \$16,604,081, with funding provided by University bond proceeds with debt service to be paid by Student Affairs; and

WHEREAS a resolution adopted by the Board of Trustees on August 29, 2001 authorized the employment of architect/engineer and construction manager firms for the Lima Campus – Student Housing project; and

WHEREAS following that authorization, a pro forma has been completed that indicates the number of beds to be included in the project should be increased from 150 to 300, resulting in a preliminary project cost increase from \$9,300,000 to \$16,604,081, with funding provided by University Bond proceeds with debt service to be paid by Student Affairs; and

WHEREAS a resolution adopted by the Board of Trustees on December 6, 2001 authorized the employment of an architect/engineer firm for the Marion Campus – Student Services Building; and

WHEREAS the Marion Campus has requested a scope change to increase the square footage to reflect the increased enrollment on the Marion Campus and the inclusion of the Alber Center (currently housed in leased space) and security services not currently on the Marion Campus resulting in a preliminary project cost increase from \$ \$3,730,169 to \$5,552,056, with funding provided by House Bill 640 (\$1,364,050), funds from the Marion Campus (\$3,088,006) and a loan from the Treasurer's Office (\$1,100,000); and

WHEREAS the Veterinary Hospital desires to construct a student lounge area within current Room 0005, including appropriate changes to lighting, electrical and HVAC, and all associated furniture and decorative items and services; and

WHEREAS the construction document project cost is \$253,583, with funding provided by the College of Veterinary Medicine; and

WHEREAS the University Airport desires to rehabilitate all existing runways, taxiways and aprons, as well as extending the North Runway (9L/27R), Taxi Way "G" and two new taxi ways that will connect both North Runway (9L/27R) and South Runway (9R/27L), with the project being planned in two phases to minimize disruption of Airport operations; Phase I will extend R/W 9L/27R West Portion, T/W G West Portion and new West End T/W and rehab R/W 5/32, T/W "C", "G", and "H"; Phase II will extend R/W 9L/27R East Portion, T/W "G" East Portion, and new East End T/W and rehab R/W 9L/ 27R and 9R/27L, T/W "A", "B", "D" and Apron; and

WHEREAS the preliminary project cost is \$8,400,000, with funding provided by a grant from the Federal Aviation Administration (\$7,560,000) and the College of Engineering (\$840,000); and

WHEREAS the Department of Athletics desires to install Musco sports lighting at the Softball Stadium; and

WHEREAS the preliminary project cost is \$349,994, with funding provided by the Department of Athletics; and

WHEREAS the University desires to renovate classrooms 200 in Campbell Hall and 014 in University Hall to improve the quality of the teaching and learning facilities and to renovate large lecture room 108 in Evans Lab; and

WHEREAS the preliminary project cost is \$2,080,184, with funding provided by House Bill 640 (\$1,512,000), House Bill 748 (\$176,224), House Bill 790 (\$230,530), House Bill 808 (\$18,850), House Bill 810 (\$72,874), House Bill 850 (\$50,826), and House Bill 904 (\$18,880); and

**EMPLOYMENT OF ARCHITECTS/ENGINEERS,
EMPLOYMENT OF CONSTRUCTION MANAGER,
REQUEST FOR CONSTRUCTION BIDS, AND
REPORT OF AWARD OF CONTRACTS (contd)**

WHEREAS the Lima Campus desires to provide an addition to Reed Hall to provide enhanced facilities for the Theatre Program, including stage expansion with backstage areas for complete theatre productions, rehearsal space, technical space, dressing rooms, green room, restrooms, seminar/classrooms, and public space; and

WHEREAS the preliminary project cost is \$1,600,000, with funding provided by gifts to the Lima Campus; and

WHEREAS a resolution adopted by the Board of Trustees on December 6, 2001 authorized the employment of architect/engineer firms for the Starling-Loving Hall - Biostatistics project; and

WHEREAS following that authorization, the Office of Research and the College of Medicine and Public Health revised the project scope to add a mezzanine level and window replacement resulting in a preliminary project cost increase from \$315,000 to \$660,911, with funding provided by Office of Research (\$558,062) and College of Medicine and Public Health (\$102,849); and

WHEREAS the University desires to competitively bid a firm fixed price indefinite quantity contract known as Job Order Contracting; and

WHEREAS separate bids for the pre-established guaranteed minimum value contract will be received for general (\$50,000), electric (\$10,000), HVAC (\$10,000), and plumbing (\$10,000) trades and a maximum contract value for general (\$8,000,000), electric (\$250,000), HVAC (\$250,000), and plumbing (\$250,000) trades; and

WHEREAS bidders will submit price adjustment factors to be applied to established fixed unit prices specified in the unit price book, with the pre-established contract value for a term of one year, with options for three additional terms of one year each; and

WHEREAS the University desires to employ an architect/engineer firm to assist with the completion of measured drawings, provide space use recommendations, and provide design services for the renovation of space in the facility at 650 Ackerman Road; and

WHEREAS the preliminary construction estimate is undetermined, with funding provided by building occupants; and

WHEREAS the Department of Athletics desires to remove and replace the artificial turf system in the Woody Hayes Athletic Facility; and

WHEREAS the preliminary project cost is \$480,000, with funding provided by the Department of Athletics and gifts to the Department of Athletics; and

WHEREAS the Department of Athletics desires to remove the existing grass field at Football Practice Field #4 and install new artificial surface field including drainage system, gravel field foundation, permanent perimeter termination structure, shock or e-layer pad, polyethylene carpet, sand and rubber infill and football field marking; and

WHEREAS the preliminary project cost is \$540,000, with funding provided by the Department of Athletics and gifts to the Department of Athletics; and

WHEREAS resolutions adopted by the Board of Trustees on December 6, 1996, February 5, 1999, June 4, 1999, October 1, 1999, July 7, 2000, August 30, 2000, December 1, 2000, February 2, 2001, May 4, 2001, June 1, 2001, August 29, 2001, March 1, 2002, April 5, 2002, May 3, 2002, July 12, 2002, and September 6, 2002 authorized the President and/or Senior Vice President for Business and Finance to request construction bids in accordance with established University procedures, and if satisfactory bids were received to award contracts for the following projects:

**EMPLOYMENT OF ARCHITECTS/ENGINEERS,
EMPLOYMENT OF CONSTRUCTION MANAGER,
REQUEST FOR CONSTRUCTION BIDS, AND
REPORT OF AWARD OF CONTRACTS (contd)**

(* Recommended alternates included in these amounts)

ATI – Shisler Center Courtyard

This project completes the exterior courtyard including landscaping. The total project cost is \$300,000; funding is provided by House Bill 640. The completion date was December 2002. The contracts awarded are as follows:

Design:	Myers Schmalenberger Inc., Columbus, Ohio
General Contract:	2K General Co., Lewis Center, Ohio
Amount:	\$242,500 *
Estimate:	\$254,150 *
Electric Contract:	Spring Electrical Construction Co., Mansfield, Ohio
Amount:	\$13,550
Estimate:	\$32,500
Total All Contracts:	\$256,050
Contingency Allowance:	\$15,279
Total Project Cost:	\$300,000

Bevis Hall Roof Replacement

This project replaces the existing EPDM roof membrane and lightweight insulation with new tapered ISO insulation and a modified bitumen roof membrane and rehabilitates concrete curbs and installs new caps and OSHA fall protection. The total project cost is \$327,350; funding is provided by House Bill 640. The estimated completion date is February 2003. The contract awarded is as follows:

Design:	Lusk & Harkin Architects and Planners, Columbus, Ohio
General Contract:	Field and Associates, Inc., Springfield, Ohio
Amount:	\$266,700
Estimate:	\$290,500
Total All Contracts:	\$266,700
Contingency Allowance:	\$26,670
Total Project Cost:	\$327,350

Bolz Hall – Roof Replacement

This project removes deteriorated built-up roof and installs a new tapered insulation, 4-ply asphalt roof, and new metal flashing. The total project cost is \$231,409; funding is provided by House Bill 748. The estimated completion date is September 2003. The contract awarded is as follows:

Design:	The Ohio State University
General Contract:	Field and Associates, Inc., Springfield, Ohio
Amount:	\$192,600
Estimate:	\$238,000
Total All Contracts:	\$192,600
Contingency Allowance:	\$19,260
Total Project Cost:	\$231,409

Byrd Polar Research Center – Rock Repository

This project constructs an approximate 5,700 square foot single-story building to house the Byrd Polar Center's Antarctic rock collection and extends the existing loading dock to connect the building with the existing cold storage building and Scott Hall. The total project cost is \$728,830; funding is provided by a National Science Foundation grant (\$503,941), Ohio Board of Regents

**EMPLOYMENT OF ARCHITECTS/ENGINEERS,
EMPLOYMENT OF CONSTRUCTION MANAGER,
REQUEST FOR CONSTRUCTION BIDS, AND
REPORT OF AWARD OF CONTRACTS (contd)**

Byrd Polar Research Center – Rock Repository (contd)

(\$94,292), Office of Research (\$75,597), Department of Geological Sciences (\$50,000), and College of Math and Physical Sciences (\$5,000). The estimated completion date is June 2003. The contracts awarded are as follows:

Design:	J. L. Bender, Inc., Columbus, Ohio
General Contract:	Central Ohio Building Co., Columbus, Ohio
Amount:	\$417,200 *
Estimate:	\$432,500 *
Plumbing Contract:	Muetzel Plumbing and Heating Co., Columbus, Ohio
Amount:	\$22,370 +
Estimate:	\$18,000
HVAC Contract:	Farber Corp., Columbus, Ohio
Amount:	\$72,680
Estimate:	\$81,000
Electric Contract:	Dynalectric Company of Ohio, Columbus, Ohio
Amount:	\$40,129 *
Estimate:	\$74,850 *
Total All Contracts:	\$552,379
Contingency Allowance:	\$33,240
Total Project Cost:	\$728,830

+ The Plumbing Contract is in excess of the filed estimate of cost; however the total price of all contracts is within 10% of the total estimate of cost and is recommended for award as provided by Section 153.12 of the Revised Code.

Campus Grounds – Neil Avenue Street Rebuild

This project upgrades the base, repairs damage caused by heavy vehicles; and rebuilds the section of road between the control gates to carry bus traffic. The total project cost is \$500,000; funding is provided by House Bill 640. The completion date was November 2002. The contract awarded is as follows:

Design:	Kinzelman/Kline, Columbus, Ohio
General Contract:	Columbus Asphalt Paving, Inc., Columbus, Ohio
Amount:	\$420,375 *
Estimate:	\$479,910 *
Total All Contracts:	\$420,375
Contingency Allowance:	\$31,819
Total Project Cost:	\$500,000

Celeste Laboratory HVAC Modifications

This project modifies pumps, piping and controls to the chilled water systems so that McPherson, Evans, Newman-Wolfram and Celeste chillers operate as a single system to improve air conditioning reliability and reduce operating and maintenance costs. The total project cost is \$419,105; funding is provided by House Bill 640. The estimated completion date is May 2003. The contracts awarded are as follows:

Design:	STAN and Associates, Dayton, Ohio
HVAC Contract:	Limbach Company, Columbus, Ohio
Amount:	\$310,200
Estimate:	\$525,000

**EMPLOYMENT OF ARCHITECTS/ENGINEERS,
EMPLOYMENT OF CONSTRUCTION MANAGER,
REQUEST FOR CONSTRUCTION BIDS, AND
REPORT OF AWARD OF CONTRACTS (contd)**

Celeste Laboratory HVAC Modifications (contd)

Electric Contract:	Dynalectric Company of Ohio, Columbus, Ohio
Amount:	\$6,486
Estimate:	\$27,000
Total All Contracts:	\$316,686
Contingency Allowance:	\$31,669
Total Project Cost:	\$419,105

Central Chilled Water Loop 17th Avenue to Derby Hall

The project extends the central chilled water system to the Dulles Hall chiller plant, which feeds Dulles, University, Bricker, and Derby Halls; replaces two chillers in Dulles Hall with variable volume pumps and a heat exchanger that will cool these buildings via the McCracken central chilled water system; and installs a 14" supply and return piping and valving underground along Neil Avenue to cross-connect the McCracken north distribution loop to the south distribution loop to provide emergency backup chilled water in either direction. The total project cost is \$800,000; funding is provided by University bond proceeds. The completion date was August 2002. The contracts awarded are as follows:

Design:	The Ohio State University, Columbus, Ohio
General Contract (phase 1):	Bale Contracting, Columbus, Ohio
Amount:	\$64,168 +
Estimate:	\$60,000 +
General Contract (phase 2):	Dorsey Construction, Columbus, Ohio
Amount:	\$43,640
Estimate:	\$70,000
HVAC Contract (phase 1):	Kirk Williams
Amount:	\$164,000
Estimate:	\$250,000
HVAC Contract (phase 2):	J. A. Guy Inc., Columbus, Ohio
Amount:	\$359,600 *
Estimate:	\$400,000 *
Electric Contract (phase 1):	Dynalectric Inc., Columbus, Ohio
Amount:	\$7,090
Estimate:	\$12,000
Electric Contract (phase 2):	Dynalectric Inc., Columbus, Ohio
Amount:	\$8,908 *
Estimate:	\$17,000 *
Total All Contracts:	\$647,406
Contingency Allowance:	\$96,197
Total Project Cost:	\$800,000

+ The General Contract (phase 1) is in excess of the filed estimate of cost; however the total price of all contracts is within 10% of the total estimate of cost and is recommended for award as provided by Section 153.12 of the Revised Code.

Cockins Hall – Math/Statistics Learning Lab

This project renovates selected areas in the basement and first floors of Cockins Hall and one suite in the Mathematics Building for the Mathematics and Statistics Learning Lab to provide open study areas, reservable rooms for peer-led study groups, computers with statistical and tutorial software, support of WEB pages and multimedia course materials and facilities for enhancing the classroom skills of tutors, TAs and lecturers. The total project cost is \$675,165; funding is provided by House Bill 850 (\$647,065), and Central University Funds (\$28,100). The completion date was November 2002. The contracts awarded are as follows:

**EMPLOYMENT OF ARCHITECTS/ENGINEERS,
EMPLOYMENT OF CONSTRUCTION MANAGER,
REQUEST FOR CONSTRUCTION BIDS, AND
REPORT OF AWARD OF CONTRACTS (contd)**

Cockins Hall – Math/Statistics Learning Lab (contd)

Design:	Schorr and Associates, Dublin, Ohio
General Contract:	C & N Construction, Columbus, Ohio
Amount:	\$158,200 *
Estimate:	\$239,414 *
Combined Plumbing/ HVAC Contract:	Pete Miller, Inc., Marion, Ohio
Amount:	\$198,400 * +
Estimate:	\$184,344 *
Electric Contract:	Knight Electric, Columbus, Ohio
Amount:	\$137,763 *
Estimate:	\$232,601 *
Asbestos Abatement Contract:	Total Environmental Services, Toledo, Ohio
Amount:	\$20,265
Estimate:	\$33,500
Total All Contracts:	\$514,628
Contingency Allowance:	\$51,463
Total Project Cost:	\$675,165

+ The Combined Plumbing/HVAC Contract is in excess of the filed estimate of cost; however the total price of all contracts is within 10% of the total estimate of cost and is recommended for award as provided by Section 153.12 of the Revised Code.

Dodd Hall – Chilled Water Plant Structure

This project replaces the chiller plant for Dodd Hall. The total project cost is \$1,074,083; funding is provided by University Hospitals. The estimated completion date is May 2003. The contracts awarded are as follows:

Design:	J. L. Bender Inc., Architects and Planners, Columbus, Ohio
General Contract:	Sali International, Inc., Columbus, Ohio
Amount:	\$200,500
Estimate:	\$232,000
Combined Plumbing/ HVAC Contract:	J. A. Guy, Inc., Columbus, Ohio
Amount:	\$610,300 *
Estimate:	\$649,230 *
Electric Contract:	Knight Electric Inc., Columbus, Ohio
Amount:	\$70,100 *
Estimate:	\$77,240 *
Total All Contracts:	\$880,900
Contingency Allowance:	\$88,090
Total Project Cost:	\$1,074,083

Evans Lab – Roof Replacement

This project replaces the built-up roofs of the original building and the north addition. The total project cost is \$325,000; funding is provided by House Bill 850. The completion date was December 2002. The contract awarded is as follows:

Design:	CTL Engineering, Inc., Columbus, Ohio
General Contract:	U.S. Roofing, Inc., Columbus, Ohio
Amount:	\$269,000 *
Estimate:	\$344,000 *

**EMPLOYMENT OF ARCHITECTS/ENGINEERS,
EMPLOYMENT OF CONSTRUCTION MANAGER,
REQUEST FOR CONSTRUCTION BIDS, AND
REPORT OF AWARD OF CONTRACTS (contd)**

Evans Lab – Roof Replacement (contd)

Total All Contracts:	\$269,000
Contingency Allowance:	\$25,265
Total Project Cost:	\$325,000

Golf Course – Men's Locker Room Renovation

This project completely upgrades the locker area with new lockers, interior finish surfaces, HVAC system and new lighting and develops a private locker area and a team meeting room for the men's golf team with a new building entry to access the new team area. The total project cost is \$464,767; funding is provided by the Department of Athletics. The estimated completion date is April 2003. The contracts awarded are as follows:

Design:	Wandel & Schnell Architects Inc., Columbus, Ohio
General Contract:	C & N Construction, Columbus, Ohio
Amount:	\$186,800
Estimate:	\$221,500
Combined Plumbing/ HVAC Contract:	Romanoff Mechanical, LLC, Gahanna, Ohio
Amount:	\$137,100 *
Estimate:	\$162,900 *
Electric Contract:	Armstrong Electric of Ohio, Carroll, Ohio
Amount:	\$43,870 *
Estimate:	\$62,000 *
Total All Contracts:	\$367,770
Contingency Allowance:	\$36,777
Total Project Cost:	\$464,767

Goss Lab – Window Replacement

This project replaces the single glazed windows with insulated double glazed windows. The total project cost is \$150,000; funding is provided by House Bill 748. The estimated completion date is November 2003. The contracts awarded are as follows:

Design:	The Ohio State University
General Contract:	C & N Construction Service, Inc., Columbus, Ohio
Amount:	\$124,400 * +
Estimate:	\$120,000 *
Asbestos Abatement Contract:	Columbus Abatement, Columbus, Ohio
Amount:	\$11,000 *
Estimate:	\$15,000 *
Total All Contracts:	\$135,400
Contingency Allowance:	\$6,770
Total Project Cost:	\$150,000

+ The General Contract is in excess of the filed estimate of cost; however the total price of all contracts is within 10% of the total estimate of cost and is recommended for award as provided by Section 153.12 of the Revised Code.

**EMPLOYMENT OF ARCHITECTS/ENGINEERS,
EMPLOYMENT OF CONSTRUCTION MANAGER,
REQUEST FOR CONSTRUCTION BIDS, AND
REPORT OF AWARD OF CONTRACTS (contd)**

Graves Hall HVAC System Upgrades

This project replaces a 500-ton centrifugal chiller that utilizes obsolete R-11 refrigerant and the cooling tower that dates from 1969, and installs a waterproof membrane in penthouse mechanical room floor. The total project cost is \$550,000; funding is provided by House Bill 640. The estimated completion date is July 2003. The contracts awarded are as follows:

Design:	The Ohio State University
General Contract:	Dreesco, Columbus, Ohio
Amount:	\$58,735 +
Estimate:	\$35,000
HVAC Contract:	Romanoff Mechanical, Gahanna, Ohio
Amount:	\$353,000 +
Estimate:	\$342,500
Electric Contract:	Dynalectric, Inc., Columbus, Ohio
Amount:	\$72,170 *
Estimate:	\$115,000 *
Total All Contracts:	\$483,905
Contingency Allowance:	\$55,650
Total Project Cost:	\$550,000

+ The General and HVAC Contracts are in excess of the filed estimate of cost; however the total price of all contracts is within 10% of the total estimate of cost and is recommended for award as provided by Section 153.12 of the Revised Code.

Graves Hall Roof Replacement

This project replaces the existing built-up roof with new tapered ISO insulation and a modified bitumen roof membrane. The total project cost is \$245,224; funding is provided by House Bill 640. The estimated completion date is September 2003. The contract awarded is as follows:

Design:	Abbot & Abbot Architects, Columbus, Ohio
General Contract:	Field and Associates, Inc., Springfield, Ohio
Amount:	\$197,600
Estimate:	\$238,950
Total All Contracts:	\$197,600
Contingency Allowance:	\$19,760
Total Project Cost:	\$245,224

Hayes Hall Roof Replacement

This project replaces the existing asphalt shingles with new roofing felts, ice and snow guard, and slate tiles to match the building original and replaces gutters and downspouts. The total project cost is \$457,500; funding is provided by House Bill 640 (\$420,000) and Department of Physical Facilities (\$37,500). The estimated completion date is October 2003. The contract awarded is as follows:

Design:	Miller Lecky Architects, Columbus, Ohio
General Contract:	Smoot Construction Co., Columbus, Ohio
Amount:	\$387,098 *
Estimate:	\$471,114 *
Total All Contracts:	\$387,098
Contingency Allowance:	\$22,236
Total Project Cost:	\$457,500

**EMPLOYMENT OF ARCHITECTS/ENGINEERS,
EMPLOYMENT OF CONSTRUCTION MANAGER,
REQUEST FOR CONSTRUCTION BIDS, AND
REPORT OF AWARD OF CONTRACTS (contd)**

Koffolt and Fontana Labs Roof Replacement

This project replaces built-up roof, installs new insulation, and removes and replaces all metal flashings. The total project cost is \$415,000; funding is provided by House Bill 850. The completion date was August 2002. The contract awarded is as follows:

Design:	Dodson Stilson, Columbus, Ohio
General Contract:	US Roofing, Columbus, Ohio
Amount:	\$290,000
Estimate:	\$340,000
Total All Contracts:	\$290,000
Contingency Allowance:	\$86,150
Total Project Cost:	\$415,000

Lima Campus – 15KV Oil Switch Replacement

This project replaces the 15KVA oil switches currently installed in Galvin Hall, Cooke Hall, and the Technical Education Laboratory to reinstate the reliability of the primary power system. The total project cost is \$122,277; funding is provided by House Bill 790 (\$9,758), House Bill 808 (\$5,999), House Bill 850 (\$81,884), House Bill 904 (\$18,398), and Senate Bill 351 (\$6,238). The estimated completion date is February 2003. The contract awarded is as follows:

Design:	D.L. Steiner, Inc., Lima, Ohio
Electric Contract:	Vaughn Industries, LLC, Carey, Ohio
Amount:	\$99,800
Estimate:	\$105,000
Total All Contracts:	\$99,800
Contingency Allowance:	\$9,980
Total Project Cost:	\$122,277

Mansfield Campus – Roadway and Parking Lot Resurfacing

This project resurfaces the approximately 1/2 mile long Mansfield main entrance roadway and heavily used parking lots (#4, #5, #6 and Tech Center), including associated storm drain inlet repairs and striping. The total project cost is \$238,263; funding is provided by House Bill 640 (\$160,000), House Bill 748 (\$53,300), and North Central Technical College (\$24,963). The estimated completion date is June 2003. The contract awarded is as follows:

Design:	K.E. McCartney and Associates, Inc., Mansfield, Ohio
General Contract:	Mansfield Asphalt Paving Company, Inc., Mansfield, Ohio
Amount:	\$173,778
Estimate:	\$252,000
Total All Contracts:	\$173,778
Contingency Allowance:	\$17,378
Total Project Cost:	\$238,263

Mirror Lake Hollow Renovation

This project replaces the wall of Mirror Lake and provides site improvements to sidewalks, steps, and landscaping. The total project cost is \$570,919; funding is provided by House Bill 850 (\$500,000) and Department of Physical Facilities (\$70,919). The estimated completion date is February 2003. The contract awarded is as follows:

**EMPLOYMENT OF ARCHITECTS/ENGINEERS,
EMPLOYMENT OF CONSTRUCTION MANAGER,
REQUEST FOR CONSTRUCTION BIDS, AND
REPORT OF AWARD OF CONTRACTS (contd)**

Mirror Lake Hollow Renovation (contd)

Design:	The Ohio State University
General Contract:	Gutknecht Construction, Columbus, Ohio
Amount:	\$503,413 * +
Estimate:	\$490,900 *
Total All Contracts:	\$503,413
Contingency Allowance:	\$30,205
Total Project Cost:	\$570,919

+ The General Contract is in excess of the filed estimate of cost; however the total price of all contracts is within 10% of the total estimate of cost and is recommended for award as provided by Section 153.12 of the Revised Code.

Multi-Purpose Turf Field

This project installs a new 130 yard turf field sited east of Lincoln Tower, including installation of turf field lighting and filming platform for a practice field for the marching band and club sports scheduled through the Department of Recreational Sports. The total project cost is \$935,990; funding is provided by Gifts to the Department of Athletics and the Marching Band (\$619,647), future University bond proceeds (\$201,718), and Department of Physical Facilities (\$114,625). The estimated completion date is February 2003. The contracts awarded are as follows:

Design:	Moody Nolan, Columbus, Ohio
Site Contract:	Specialty Surfaces International Inc., Conshohocken, PA
Amount:	\$582,932 *
Estimate:	\$803,436 *
Electric Contract:	Dynalectric Company of Ohio, Columbus, Ohio
Amount:	\$184,890
Estimate:	\$190,000
Total All Contracts:	\$767,822
Contingency Allowance:	\$76,782
Total Project Cost:	\$935,990

OARnet – HVAC and Electrical Improvements

This project installs a universal power supply system, generator, HVAC and new 3-phase 208-volt service at 1454 West Lane Avenue. The total project cost is \$208,589; funding is provided by the Ohio Board of Regents. The estimated completion date is February 2003. The contracts awarded are as follows:

Design:	The Ohio State University
HVAC Contract:	Command Heating, Grove City, Ohio
Amount:	\$118,675
Estimate:	\$122,400
Electric Contract:	Atlas Industrial Electric Co., Columbus, Ohio
Amount:	\$68,400
Estimate:	\$102,368
Total All Contracts:	\$187,075
Contingency Allowance:	\$18,707
Total Project Cost:	\$208,589

**EMPLOYMENT OF ARCHITECTS/ENGINEERS,
EMPLOYMENT OF CONSTRUCTION MANAGER,
REQUEST FOR CONSTRUCTION BIDS, AND
REPORT OF AWARD OF CONTRACTS (contd)**

Orton Hall Roof Replacement

This project replaces the existing asphalt tile shingles with new clay tile as originally installed, the existing graduated clay tile on the bell tower with new graduated clay tile, and the building gutter with new copper metal. The total project cost is \$697,434; funding is provided by House Bill 790 (\$149,725), House Bill 850 (\$540,000), and Department of Physical Facilities (\$7,709). The estimated completion date is February 2003. The contract awarded is as follows:

Design:	Chambers, Murphy, and Burge, Akron, Ohio
General Contract:	The Tradesman Group, Columbus, Ohio
Amount:	\$601,440 *
Estimate:	\$643,634 *
Total All Contracts:	\$601,440
Contingency Allowance:	\$30,072
Total Project Cost:	\$697,434

Page Hall Renovation

This project renovates Page Hall to house the John Glenn Institute. The total project cost is \$16,000,000; funding is provided by gifts to Academic Affairs (\$5,000,000), House Bill 640 (\$10,300,000), and House Bill 850 (\$700,000). The estimated completion date is August 2004. The contracts awarded are as follows:

Design:	Miller/Watson Architects, Ltd., Columbus, Ohio
General Contract:	Danis Building Construction Company, Dublin, Ohio
Amount:	\$7,724,500 * +
Estimate:	\$7,696,814 *
Plumbing Contract:	Fox Mechanical, Columbus, Ohio
Amount:	\$551,440
Estimate:	\$554,509
HVAC Contract:	Bruner Corporation, Hilliard, Ohio
Amount:	\$1,789,000
Estimate:	\$2,030,700
Electric Contract:	Roberts Electrical Construction Co., Columbus, Ohio
Amount:	\$1,538,000 +
Estimate:	\$1,084,952
Asbestos Abatement	
Contract:	Total Environmental Services, Toledo, Ohio
Amount:	\$45,365
Estimate:	\$65,000
Total All Contracts:	\$11,648,305
Contingency Allowance:	\$990,416
Total Project Cost:	\$16,000,000

+ The General and Electric contract are in excess of the filed estimate of cost; however the total price of all contracts is within 10% of the total estimate of cost and is recommended for award as provided by Section 153.12 of the Revised Code.

Parker Food Science – Pilot Plant Facility

This project constructs a Pulsed Electrical Field Research and Development Pilot Plant Facility in the basement of the Parker Food Science and Technology Building. The total project cost is \$659,000; funding is provided by the College of Food, Agricultural and Environmental Sciences (\$589,000) and Office of Research (\$70,000). The completion date was September 2002. The contract awarded is as follows:

**EMPLOYMENT OF ARCHITECTS/ENGINEERS,
EMPLOYMENT OF CONSTRUCTION MANAGER,
REQUEST FOR CONSTRUCTION BIDS, AND
REPORT OF AWARD OF CONTRACTS (contd)**

Parker Food Science – Pilot Plant Facility (contd)

Design:	Burgess and Niple, Ltd., Columbus, Ohio
General Contract:	Childers Corp., Columbus, Ohio
Amount:	\$577,500
Estimate:	\$650,000
Total All Contracts:	\$577,500
Contingency Allowance:	\$38,855
Total Project Cost:	\$659,000

Physical Sciences Research Building

This project demolishes the existing Welding Engineering Building and constructs a new facility to partially house the Department of Physics. The total project cost is \$52,930,296; funding is provided by central University funds (\$1,940,615), gifts to the College of Mathematics and Physical Sciences (\$401,221), Department of Physics (\$150,000), House Bill 640 (\$26,200,000), House Bill 748 (\$4,000,000), House Bill 850 (\$20,000,000), and Department of Physical Facilities (\$238,460). The estimated completion date is September 2004. The contracts awarded are as follows:

Design:	JBA Architects, Newark, Ohio
Construction Manager:	Turner Construction, Worthington, Ohio
Asbestos Abatement Contract:	Columbus Abatement, Columbus, Ohio
Amount:	\$29,500
Estimate:	\$48,400
Demolition Contract:	Roberts Construction and Demolition, Newark, Ohio
Amount:	\$158,000
Estimate:	\$300,000
Earthwork/Site Utilities/Sheeting And Shoring Contract:	George J. Igel & Co., Inc., Columbus, Ohio
Amount:	\$1,901,350 * +
Estimate:	\$1,880,000 *
Structural Concrete Contract:	Dugan and Meyers Construction Services, Ltd., Columbus, Ohio
Amount:	\$5,592,500 * +
Estimate:	\$5,461,500 *
Structural Steel/Misc. Metals/ Stairs Contract:	Wanner Metal Worx, Inc., Delaware, Ohio
Amount:	\$1,424,000 +
Estimate:	\$1,276,000
Masonry Contract:	Northern Valley Contractors, Inc., North Canton, Ohio
Amount:	\$2,249,500 +
Estimate:	\$2,078,000
Aluminum/Glass Contract:	Anderson Aluminum Corp., Columbus, Ohio
Amount:	\$1,525,000
Estimate:	\$1,788,000
Roofing Contract:	South Texas and Lone Star Drywall, Columbus, Ohio
Amount:	\$437,810
Estimate:	\$477,000
Elevators Contract:	Thyssen Krupp Elevator Co., Westerville, Ohio
Amount:	\$529,000 +
Estimate:	\$510,000
Combined Plumbing/HVAC Contract:	Kirk Williams Company, Inc., Grove City, Ohio
Amount:	\$11,111,000 * +
Estimate:	\$10,426,915 *

**EMPLOYMENT OF ARCHITECTS/ENGINEERS,
EMPLOYMENT OF CONSTRUCTION MANAGER,
REQUEST FOR CONSTRUCTION BIDS, AND
REPORT OF AWARD OF CONTRACTS (contd)**

Physical Sciences Research Building (contd)

Fire Protection Contract:	Central Fire Protection Co., Inc., Springfield, Ohio
Amount:	\$564,697 +
Estimate:	\$524,000
Electric Contract:	Buckeye Electric Co., Dayton, Ohio
Amount:	\$5,330,585
Estimate:	\$6,600,775
General Conditions Contract:	Teemok Construction, Inc., Columbus, Ohio
Amount:	\$729,300
Estimate:	\$760,000
Equipment/Furnishings/Lab Casework Contract:	Smith and Schaefer, Inc., Cincinnati, Ohio
Amount:	\$1,416,812 *
Estimate:	\$1,480,300 *
General Trades/Doors/ Hardware Contract:	Apex/M & P Construction, Blacklick, Ohio
Amount:	\$2,370,450 * +
Estimate:	\$1,721,300 *
Framing/Drywall and Ceilings Contract:	Cleveland Construction, Inc., Mason, Ohio
Amount:	\$2,865,200 *
Estimate:	\$3,114,500 *
Painting Contract:	Kastra Painting, Lewis Center, Ohio
Amount:	\$389,400
Estimate:	\$492,000
Flooring Contract:	South Texas & Lone Star Drywall, Columbus, Ohio
Amount:	\$1,064,000
Estimate:	\$1,112,000
Hardscape Contract:	George J. Igel and Co., Columbus, Ohio
Amount:	\$525,400 +
Estimate:	\$197,500
Landscape Contract:	Greenscapes Landscape Co., Inc., Columbus, Ohio
Amount:	\$112,043 +
Estimate:	\$107,200
Total All Contracts:	\$40,325,547
Contingency Allowance:	\$2,298,557
Total Project Cost:	\$52,930,296

+ The Earthwork/Site Utilities/Sheeting and Shoring, Structural Concrete, Structural Steel/Misc. Metals/Stairs, Masonry, Elevators, Combined Plumbing/HVAC, Fire Protection, General Trades/Doors/Hardware, Hardscape, and Landscape contracts are in excess of the filed estimate of cost; however the total price of all contracts is within 10% of the total estimate of cost and is recommended for award as provided by Section 153.12 of the Revised Code.

Postle Hall – Oral and Maxillofacial Surgery

This project renovates areas to reconfigure space for Oral and Maxillofacial Surgical Services -- climate control, walls, floors, ceilings, etc. The total project cost is \$889,121; funding is provided by the College of Dentistry. The estimated completion date is February 2003. The contracts awarded are as follows:

Design:	Robert S. Davis, Ltd., Powell, Ohio
General Contract:	Triad CM, Columbus, Ohio
Amount:	\$261,600
Estimate:	\$459,131

**EMPLOYMENT OF ARCHITECTS/ENGINEERS,
EMPLOYMENT OF CONSTRUCTION MANAGER,
REQUEST FOR CONSTRUCTION BIDS, AND
REPORT OF AWARD OF CONTRACTS (contd)**

Postle Hall – Oral and Maxillofacial Surgery (contd)

Plumbing Contract:	LTM Plumbing, Columbus, Ohio
Amount:	\$129,435
Estimate:	\$129,850
HVAC Contract:	Martina Metal, Columbus, Ohio
Amount:	\$189,100 *
Estimate:	\$214,600
Electric Contract:	Knight Electric, Columbus, Ohio
Amount:	\$94,521
Estimate:	\$151,500
Total All Contracts:	\$674,656
Contingency Allowance:	\$91,116
Total Project Cost:	\$889,121

Riverwatch Tower – Suites B and C

This project renovates office space for the University Treasurer's staff located on the ground floor of Riverwatch Tower; work includes selective demolition, some new walls and doors, painting, carpeting, new ceilings and lighting, minor mechanical upgrades, data and electrical upgrades, office furniture, and ADA upgrades to the restrooms. The total project cost is \$375,656; funding is provided by Business and Finance. The estimated completion date is March 2003. The contract awarded is as follows:

Design:	DSI Architects, Columbus, Ohio
Combined General/Plumbing/ HVAC/Electrical Contract:	C & N Construction, Columbus, Ohio
Amount:	\$254,200 *
Estimate:	\$314,938 *
Total All Contracts:	\$254,200
Contingency Allowance:	\$91,618
Total Project Cost:	\$375,656

Starling-Loving Hall Renovation

This project renovates selected spaces in the basement M-Wing of Starling-Loving Hall. The total project cost is \$748,825; funding is provided by House Bill 640 (\$682,000) and College of Medicine and Public Health (\$66,825). The estimated completion date is November 2003. The contracts awarded are as follows:

Design:	Miller Lecky Architects, Inc., Columbus, Ohio
General Contract:	The Righter Co., Inc., Columbus, Ohio
Amount:	\$224,879 *
Estimate:	\$333,480 *
Combined Plumbing and HVAC Contract:	Farber Mechanical, Columbus, Ohio
Amount:	\$246,310 * +
Estimate:	\$241,987 *
Electric Contract:	Roberts Electric, Columbus, Ohio
Amount:	\$79,180 *
Estimate:	\$108,333 *
Total All Contracts:	\$550,369
Contingency Allowance:	\$82,555
Total Project Cost:	\$748,825

**EMPLOYMENT OF ARCHITECTS/ENGINEERS,
EMPLOYMENT OF CONSTRUCTION MANAGER,
REQUEST FOR CONSTRUCTION BIDS, AND
REPORT OF AWARD OF CONTRACTS (contd)**

Starling-Loving Hall Renovation (contd)

+ The Combined Plumbing and HVAC Contract is in excess of the filed estimate of cost; however the total price of all contracts is within 10% of the total estimate of cost and is recommended for award as provided by Section 153.12 of the Revised Code.

University Hospitals/Rhodes Hall Entrance

This project expands the entrance to Rhodes Hall. The total project cost is \$292,482; funding is provided by University Hospitals. The estimated completion date is February 2003. The contracts awarded are as follows:

Design:	Bass Studio Architects, Columbus, Ohio
General Contract:	The Albert M. Higley Co., Columbus, Ohio
Amount:	\$179,860 +
Estimate:	\$152,000
Plumbing Contract:	Gateway Mechanical, Inc., Grove City, Ohio
Amount:	\$19,200 +
Estimate:	\$10,000
HVAC Contract:	Comfort Express, Inc., Delaware, Ohio
Amount:	\$15,600
Estimate:	\$22,500
Electric Contract:	Buckeye Electrical Services, Columbus, Ohio
Amount:	\$27,938
Estimate:	\$39,000
Total All Contracts:	\$242,496
Contingency Allowance:	\$24,250
Total Project Cost:	\$292,482

+ The General and Plumbing Contracts are in excess of the filed estimate of cost; however the total price of all contracts is within 10% of the total estimate of cost and is recommended for award as provided by Section 153.12 of the Revised Code.

Wiseman Hall – Comprehensive Cancer Center

This project constructs a two-story addition of approximately 20,000 square feet to the existing Comprehensive Cancer Center extending the third and fourth floors over the north side, second floor of Wiseman Hall. The total project cost is \$8,848,115; funding is provided by the James Cancer Hospital and Solove Research Institute (\$8,813,115) and Department of Physical Facilities (\$35,000). The estimated completion date is January 2004. The contracts awarded are as follows:

Design:	URS Corporation, Columbus, Ohio
General Contract:	Smoot Construction Company of Ohio, Columbus, Ohio
Amount:	\$3,770,500 * +
Estimate:	\$3,124,720 *
Plumbing Contract:	General Temperature Control, Inc., Canal Winchester, Ohio
Amount:	\$591,930 * +
Estimate:	\$544,891 *
HVAC Contract:	Bruner Corporation, Hilliard, Ohio
Amount:	\$1,961,900 *
Estimate:	\$2,331,039 *
Electric Contract:	Reddy Electric, Xenia, Ohio
Amount:	\$1,221,620 *
Estimate:	\$1,736,698 *

**EMPLOYMENT OF ARCHITECTS/ENGINEERS,
EMPLOYMENT OF CONSTRUCTION MANAGER,
REQUEST FOR CONSTRUCTION BIDS, AND
REPORT OF AWARD OF CONTRACTS (contd)**

Wiseman Hall – Comprehensive Cancer Center (contd)

Total All Contracts: \$7,545,950
Contingency Allowance: \$692,999
Total Project Cost: \$8,848,115

+ The General and Plumbing Contracts are in excess of the filed estimate of cost; however the total price of all contracts is within 10% of the total estimate of cost and is recommended for award as provided by Section 153.12 of the Revised Code.

Women's Field House Relocation

This project relocates the Women's Field House from behind Larkins Hall to east of Lincoln Tower for use as an educational classroom building. The project includes replicating the existing grading conditions, restoration of the exterior wood siding, hazardous material abatement, and bringing all utilities to the new site for hook-up. The estimated completion date is February 2003. The contracts awarded are as follows:

Design: Renouveau Design Inc., Columbus, Ohio
General Contract: Righter Construction Services Inc., Columbus, Ohio
 Amount: \$330,575 +
 Estimate: \$310,372
Mechanical Contract: J. A. Guy, Inc., Dublin, Ohio
 Amount: \$134,000 +
 Estimate: \$122,074
Electric Contract: Dynalectric Company of Ohio, Columbus, Ohio
 Amount: \$53,683
 Estimate: \$61,000
Moving Contract: Dingey Movers, Inc., Zanesville, Ohio
 Amount: \$69,500
 Estimate: \$119,387
Total All Contracts: \$587,758
Contingency Allowance: \$36,077
Total Project Cost: \$671,935

+ The General and Mechanical Contracts are in excess of the filed estimate of cost; however the total price of all contracts is within 10% of the total estimate of cost and is recommended for award as provided by Section 153.12 of the Revised Code.

NOW THEREFORE

BE IT RESOLVED, That the President and/or Senior Vice President for Business and Finance be authorized to select qualified architectural/engineering firms as necessary for the Marion Campus – Student Housing, Lima Campus – Student Housing, Marion Campus – Student Services Building, Airport Pavement Rehabilitation/Extension – Phase I, 650 Ackerman Road – Renovation, Woody Hayes Athletic Facility – Turf Replacement, and Football Practice Field #4 – Turf Installation projects and that the fees for these services be negotiated between the firms selected and the University; and

BE IT FURTHER RESOLVED, That the President and/or Senior Vice President for Business and Finance be authorized to select qualified construction manager firms as necessary for the Marion Campus – Student Housing and Lima Campus – Student Housing projects and that the fees for these services be negotiated between the firms selected and the University; and

BE IT FURTHER RESOLVED, That the President and/or Senior Vice President for Business and Finance be authorized to request construction bids for the Veterinary Hospital – Student Lounge Renovation, Softball Stadium Sports Lighting, Campbell Hall, University Hall, and Evans Lab

**EMPLOYMENT OF ARCHITECTS/ENGINEERS,
EMPLOYMENT OF CONSTRUCTION MANAGER,
REQUEST FOR CONSTRUCTION BIDS, AND
REPORT OF AWARD OF CONTRACTS (contd)**

Renovation, Lima Campus – Reed Hall Theatre Addition, Starling-Loving Hall – Biostatistics, and Job Order Contract 2003 projects in accordance with established University and State of Ohio procedures, and if satisfactory bids are received, to issue contracts with all actions to be reported to this Board at the appropriate time; and

BE IT FURTHER RESOLVED, That pursuant to the actions previously authorized by the Board, the report of award of contracts and establishment of contingency funds for the ATI – Shisler Center Courtyard, Bevis Hall Roof Replacement, Bolz Hall – Roof Replacement, Byrd Polar Research Center – Rock Repository, Campus Grounds – Neil Avenue Street Rebuild, Celeste Laboratory HVAC Modifications, Central Chilled Water Loop 17TH Avenue to Derby Hall, Cockins Hall – Math/Statistics Learning Lab, Dodd Hall – Chilled Water Plant Structure, Evans Lab – Roof Replacement, Golf Course – Men’s Locker Room Renovation, Goss Lab – Window Replacement, Graves Hall HVAC System Upgrades, Graves Hall Roof Replacement, Hayes Hall Roof Replacement, Koffolt and Fontana Labs Roof Replacement, Lima Campus – 15KV Oil Switch Replacement, Mansfield Campus – Roadway and Parking Lot Resurfacing, Mirror Lake Hollow Renovation, Multi-Purpose Turf Field, OARnet – HVAC and Electrical Improvements, Orton Hall Roof Replacement, Page Hall Renovation, Parker Food Science – Pilot Plant Facility, Physical Sciences Research Building, Postle Hall – Oral and Maxillofacial Surgery, Riverwatch Tower - Suites B and C, Starling-Loving Hall Renovation, University Hospital/Rhodes Hall Entrance, Wiseman Hall – Comprehensive Cancer Center, and Women’s Field House Relocation projects is hereby accepted.

(See Appendix XXXVI for background information and maps, page 767.)

**AWARD OF MEDICAL PROGRAMS CLAIMS ADMINISTRATION
SERVICES CONTRACT AND LEASED PROVIDER NETWORK**

Resolution No. 2003-88

Synopsis: The award of claims administration services for the University's medical insurance benefits programs is proposed.

WHEREAS after specification and proposal forms were mailed to eighteen companies: fifteen attended a pre-bid conference, of which all fifteen submitted proposals for consideration; and

WHEREAS Aon Consulting was employed to assist the Associate Vice President for Human Resources in the investigation and analysis of the proposals; and

WHEREAS the appropriate University offices have reviewed the proposals, and based on financial considerations, claims processing capability and other administrative services to be provided, it is the recommendation of the Office of Human Resources with the concurrence of the Purchasing Department that NGS American, Incorporated, be awarded the claims administration services contract and that Medical Mutual of Ohio be awarded the provider network contract for covered faculty and staff outside central Ohio.

Quoted rates for administrative services and provider network access are:

**AWARD OF MEDICAL PROGRAMS CLAIMS ADMINISTRATION
SERVICES CONTRACT AND LEASED PROVIDER NETWORK (contd)**

Medical Plan

Administrative Cost Per Person Per Month

	NGS American	Medical Mutual of Ohio
• University PrimeCare	\$ 13.64	\$3.50
• OSU Health Plan	\$ 13.64	\$3.50
• Traditional Health Plan	\$ 13.64	
• Buckeye Health Plan	\$ 13.64	

Estimated first year annual cost including start-up fees \$3,232,000.00

NOW THEREFORE

BE IT RESOLVED, That the contract for claims administration services for the University's medical insurance benefits plans be awarded to NGS American, Incorporated, and the contract for the provider network outside central Ohio be awarded to Medical Mutual of Ohio. These contracts are for a one-year period effective July 1, 2003, with the fees and performance to be reviewed annually. These contracts will remain in force after the initial term until the University deems it appropriate to review the designation of the administrator and provider network and/or seek a new price quotation. Price increases for the NGS American contract for the first three renewals, i.e., through June 30, 2007, are limited to 3% or less per year. The Senior Vice President for Business and Finance, in consultation with the Associate Vice President for Human Resources, is authorized to negotiate the subsequent annual renewal agreements and to take any other appropriate action to manage these ongoing contracts.

Upon motion of Ms. Longaberger, seconded by Mr. Sofia, the Board of Trustees adopted the foregoing resolutions by unanimous roll call vote, cast by Messrs. Patterson, Sofia, Slane, McFerson, Borrer, and Judge Duncan, Mses. Longaberger, Hendricks, and Davidson.

--0--

**AUTHORIZATION, ISSUANCE AND SALE OF
GENERAL RECEIPTS BONDS
SERIES 2003 A OF THE OHIO STATE UNIVERSITY**

Resolution No. 2003-89

Synopsis: Providing for the authorization, issuance and sale of General Receipts (the "Series 2003 A Bonds"), in a principal amount determined as provided herein, for the purposes of (A) currently refunding the outstanding principal amount of certain Series 1992 A Bonds of the University (the "Refunded Bonds"); (B) paying costs and expenses associated with the issuance of the 2003 A Bonds.

WHEREAS pursuant to Sections 3345.11 and 3345.12 of the Ohio Revised Code (the "Act"), as enacted under authority of the Constitution of Ohio, particularly Section 2i of Article VIII thereof, The Ohio State University (the "University"), a state university of the State of Ohio (the "State"), created and existing under Chapter 3335 of the Ohio Revised Code, is authorized and empowered, among other things, (a) to issue, as provided herein, Obligations (as defined in the Indenture (as hereinafter defined)) of the University to pay the costs of certain capital facilities defined as "facilities" in the Act (and herein called "University Facilities") and to refund, fund or retire bonds and other obligations previously issued for such purpose; (b) to pledge to the payment of the Obligations all or a specified part of the gross amount of the General Receipts of the University (as defined in the Original Indenture) in priority to all other expenses, claims or payments; (c) to covenant, as herein provided, that the University will make, fix, adjust and collect the fees, rates, rentals, charges and other items comprising General Receipts to produce General Receipts sufficient at all times to meet Debt Service Charges (as defined in the Amended and Restated Trust Indenture described below) on the Obligations, to establish and to maintain the required reserves and meet other requirements herein provided; and (d) to provide for a trust indenture and make further provisions for securing the payment of the Debt Service Charges; and

**AUTHORIZATION, ISSUANCE AND SALE OF
GENERAL RECEIPTS BONDS
SERIES 2003 A OF THE OHIO STATE UNIVERSITY (contd)**

WHEREAS the University, by resolution adopted by its Board of Trustees (the "Board") on November 1, 1985 (the "Series 1985 A Bond Resolution") and by a Trust Indenture dated as of November 15, 1985 (the "Original Indenture") between the University and The Huntington National Bank, as Trustee (the "Trustee"), provided for the issuance from time to time of General Receipts Bonds of the University; and

WHEREAS the University, pursuant to the terms of a resolution adopted by the Board on October 1, 1999 (the "1999 General Bond Resolution") amended and restated the Original Indenture, as supplemented in accordance with the terms thereof by entering into the Amended and Restated Trust Indenture dated as of December 1, 1999 (the "Amended and Restated Trust Indenture") with the Trustee; and

WHEREAS the Amended and Restated Indenture provides that Obligations, as defined therein, may be issued pursuant to the terms thereof, with each such issue to be authorized by a Series Resolution, as defined therein, adopted by the Board and secured pursuant to the terms of a Supplemental Indenture, as defined in the Amended and Restated Indenture with respect to such issue (the Amended and Restated Indenture and all Supplemental Indentures thereto being collectively referred to herein as the "Indenture"); and

WHEREAS the University has authorized the issuance pursuant to the 1999 General Bond Resolution, the resolution adopted by the Board on November 5, 1999 (the "Series 1999 A General Receipts Bond Resolution"), the Indenture and the First Supplement to Amended and Restated Trust Indenture, dated as of December 1, 1999 (the "First Supplement") between the University and the Trustee, \$83,585,000 The Ohio State University General Receipts Bonds, Series 1999 A (the "Series 1999 A Bonds") of which authorized amount \$75,190,000 is issued and outstanding as of the date hereof; and

WHEREAS the University has authorized the issuance pursuant to the 1999 General Bond Resolution, the resolution adopted by the Board on November 5, 1999 (the "Series 1999 B General Receipts Bond Resolution"), the Indenture and the Second Supplement to Amended and Restated Trust Indenture, dated as of December 1, 1999 (the "Second Supplement") between the University and the Trustee, \$108,000,000 The Ohio State University Variable Rate Demand General Receipts Bonds, Series 1999 B (the "Series 1999 B Bonds") of which authorized amount \$84,900,000 is issued and outstanding as of the date hereof; and

WHEREAS the University has authorized the issuance pursuant to the 1999 General Bond Resolution, the Resolution adopted by the Board on November 2, 2001 (the "Series 2001 General Receipts Bond Resolution"), the Indenture and the Series 2001 Supplement to Amended and Restated Trust Indenture, dated as of November 1, 2001 (the "Series 2001 Supplement") between the University and the Trustee, \$79,950,000 The Ohio State University Variable Rate Demand General Receipts Bonds, Series 2001 (the "Series 2001 Bonds") of which amount \$76,950,000 is issued and outstanding as of the date hereof; and

WHEREAS the University has authorized the issuance pursuant to the 1999 General Bond Resolution, the Resolution adopted by the Board on November 2, 2001 (the "Series D Commercial Paper Resolution") the Indenture and Series D) Supplement to the Amended and Restated Trust Indenture, dated as of December 1, 2001 (the "Series D Supplement") between the University and the Trustee, \$175,000,000 The Ohio State University General Receipts Commercial Paper Notes, Series D (the "Series D Notes" of which amount \$47,000,000 is issued and outstanding as of the date hereof; and

WHEREAS the University has authorized the issuance pursuant to the 1999 General Bond Resolution, the Resolution adopted by the Board on November 2, 2001 (the "Series 2002 A General Receipts Bond Resolution"), the Indenture and the Series 2002 A Supplement to Amended and Restated Trust Indenture, dated as of January 1, 2002 (the "Series 2002 A Supplement") between the University and the Trustee, \$150,515,000 The Ohio State University

**AUTHORIZATION, ISSUANCE AND SALE OF
GENERAL RECEIPTS BONDS
SERIES 2003 A OF THE OHIO STATE UNIVERSITY (contd)**

General Receipts Bonds, Series 2002 A (the "Series 2002 A Bonds"), of which amount \$145,075,000 is issued and outstanding as of the date hereof; and

WHEREAS the Board has determined that it is in the best interests of the University to authorize the issuance of The Ohio State University General Receipts Refunding Bonds, Series 2003 A (the "Series 2003 A Bonds") in the principal amount not to exceed \$53,000,000 for the purpose of currently refunding certain of the Series 1992 A Bonds (the "Refunded Bonds"), and paying costs and expenses associated with the issuance of the Series 2003 A Bonds; and

WHEREAS the University desires to make provisions for the issuance of the Series 2003 A Bonds and for the payment of the Debt Service Charges thereon and the securing thereof by this Resolution and a 2003 A Supplement to the Amended and Restated Trust Indenture (the "2003 A Supplement" and together with the Amended and Restated Trust Indenture, the "Indenture") herein authorized:

NOW THEREFORE

BE IT RESOLVED BY THE BOARD OF TRUSTEES OF THE OHIO STATE UNIVERSITY as follows:

Section 1. Definitions and Interpretations. All words and terms defined in the Amended and Restated Indenture and all interpretations therein provided shall have in this Resolution the same meanings, respectively, and be subject to the same interpretations as therein provided or used, unless the context or use clearly indicates another or different meaning or intent. Terms not appearing in the Amended and Restated Indenture but used herein and not previously defined herein are defined as follows:

"Certificate of Award" means the Certificate of Award authorized pursuant to Section 3 of this Resolution.

"Code" means the Internal Revenue Code of 1986, as amended, the Treasury Regulations (whether proposed, temporary or final) under that Code or the statutory predecessor of that Code, and any amendments of, or successor provisions to, the foregoing and any official rulings, announcements, notices, procedures and judicial determinations regarding any of the foregoing, all as and to the extent applicable. Unless otherwise indicated, reference to a Section of the Code means that Section, including any applicable successor section or provision and such applicable Treasury Regulations, rulings, announcements, notices, procedures and determinations pertinent to that Section.

"Contract of Purchase" means the Contract of Purchase between the Original Purchaser and the University, authorized pursuant to Section 3 hereof.

"Offering Memorandum" means, as to the Series 2003 A Bonds, the Offering Memorandum relating to the original issuance of the Series 2003 A Bonds, authorized pursuant to Section 3 hereof.

"Original Purchasers" means, as to the Series 2003 A Bonds, Seasongood & Mayer LLC and Morgan Stanley & Co. Incorporated.

"Paying Agent" means the Trustee.

"Refunded Bonds" means the outstanding principal amount of the General Receipts to Bonds, Series 1992 A of the University.

"Series 2003 A Bond Resolution" or "this Resolution" as used herein, means this Resolution and the Certificate of Award, as the same may be amended from time to time.

**AUTHORIZATION, ISSUANCE AND SALE OF
GENERAL RECEIPTS BONDS
SERIES 2003 A OF THE OHIO STATE UNIVERSITY (contd)**

Any reference herein to the University, the Board, or to any members or officers thereof or to other public boards, commissions, departments, institutions, agencies, bodies, entities or officers, shall include those which succeed to their functions, duties or responsibilities pursuant to or by operation of law or who are lawfully performing their functions. Any reference to a section or provision of the Ohio Revised Code or to the laws of Ohio shall include such section or provision and such laws as from time to time amended, modified, revised, supplemented, or superseded, provided that no such amendment, modification, revision, supplementation, or supersession shall alter the obligation to pay the Debt Service Charges in the amount and manner, at the times, and from the sources provided in this Resolution, the Amended and Restated Trust Indenture and the 2003 A Supplement, except as otherwise herein permitted.

Unless the context shall otherwise indicate, words importing the singular number shall include the plural number, and vice versa, and the terms "hereof," "herein," "hereby," "hereto," "hereunder," and similar terms, mean this Resolution.

Section 2. Authorization; Terms; Pledge; and Covenant.

(a) Authorization. The Series 2003 A Bonds shall be designated and known as "The Ohio State University General Receipts Refunding Bonds, Series 2003 A" and shall be issued pursuant to and as authorized by the Act, Section 2i of Article VIII of the Ohio Constitution, this Resolution, the Amended and Restated Trust Indenture and the 2003 A Supplement. The Series 2003 A Bonds shall be issued for the purpose of currently refunding of the outstanding principal amount of the Series 1992 A Bonds and paying costs and expenses incidental to the issuance of the Series 2003 A Bonds.

(b) Form and Numbering. The Series 2003 A Bonds shall be issued only as fully registered bonds. The Series 2003 A Bonds shall be numbered as determined by the Trustee which will distinguish each Series 2003 A Bond from each other Series 2003 A Bond.

(c) Denominations and Dates. The Series 2003 A Bonds shall be issuable in denominations of \$100,000 and integral multiples of \$5,000 in excess thereof and shall be dated as of February 1, 2003.

(d) Principal Amount. The Series 2003 A Bonds shall be issued in the principal amount specified in the Certificate of Award, which amount shall not exceed \$53,000,000.

(e) Delivery and Execution. The Treasurer is hereby authorized to make the necessary arrangements with the Original Purchaser to establish the date, location, procedures and conditions for the delivery of the Series 2003 A Bonds to the Original Purchaser and to take all steps as necessary to effect due execution, authentication, sale and delivery of the Series 2003 A Bonds to the Original Purchaser under the terms of this Resolution. The Series 2003 A Bonds shall be signed by the Treasurer in his official capacity (provided such signature may be a facsimile) and may bear the corporate seal of the University or a facsimile thereof.

(f) Interest and Maturities.

(i) The Series 2003 A Bonds shall bear interest on the unpaid principal amount thereof from the most recent date to which interest has been paid or duly provided for or, if no interest has been paid or provided for, from their date, with interest payable at their maturity at the percentage rate or rates per annum set forth in the Certificate of Award. Interest shall be calculated on the basis of a 360-day year consisting of twelve 30-day months. Such rate or rates shall in no event produce an interest rate for the Series 2003 A Bonds in excess of five percent (5.00%) per annum.

(ii) The Series 2003 A Bonds shall mature not later than September 15, 2003 as provided for in the Certificate of Award.

**AUTHORIZATION, ISSUANCE AND SALE OF
GENERAL RECEIPTS BONDS
SERIES 2003 A OF THE OHIO STATE UNIVERSITY (contd)**

(iii) The Series 2003 A Bonds, if so provided for in the Certificate of Award, shall be subject to optional redemption at the option of the University prior to stated maturity, in whole or in part, but if in part, only in installments of \$100,000 principal amount of such Series 2003 A Bond or integral multiples of \$5,000 in excess thereof, in accordance with the terms, conditions, redemption prices and on the dates set forth in the Certificate of Award. Notice of call for and other terms and provisions governing redemption of the Series 2003 A Bonds shall be given in the manner provided in the Indenture. At no time shall the redemption price on any Series 2003 A Bonds, exclusive of accrued interest, exceed one hundred percent (100%) of the principal amount of such Bond to be redeemed.

(g) Security. As provided in the Amended and Restated Trust Indenture as supplemented by the 2003 A Supplement, there is hereby pledged to the security of the Series 2003 A Bonds and for the payment of the Debt Service Charges on the Series 2003 A Bonds, (i) the gross amount of General Receipts of the University (subject to the provisions for the partial release of a pledge of General Receipts contained in Section 4.11 of the Original Indenture) and (ii) the monies contained in the Special Funds, but excluding the Bond Reserve Fund. Anything else to the contrary in the Indenture or this Resolution notwithstanding, the Series 2003 A Bonds shall not have access to, any claim upon or be secured by the Bond Reserve Fund or the Note Program Fund.

The pledge of General Receipts in the immediately preceding paragraph shall be on a parity with expenses, claims and payments relating to other Parity Obligations and in priority to all other expenses, claims and payments of the University. In accordance with the Act, all General Receipts or portions thereof are immediately subject to the lien of the pledge upon receipt thereof by the University. Furthermore, the Pledge contained herein and the Amended and Restated Indenture is not in derogation of the pledge contained in the Original Indenture, any supplement thereto Indenture, any Series Resolution adopted pursuant to the Original Resolution or any Bond proceedings with respect to any Obligations currently outstanding, it being the intention of the University that all such Obligations outstanding upon the execution and delivery of the Series 2003 A Supplement shall be Parity Obligations within the meaning of the Amended and Restated Trust Indenture, equally and ratably secured by the pledge of General Receipts of the University herein and therein contained.

For the further security of the Series 2003 A Bonds, and any other Obligations, the University hereby covenants with the bondholders and the Trustee that so long as any Series 2003 A Bonds or Obligations are outstanding, the University shall fix, make, adjust and collect fees, rates, rentals, charges, and other items of General Receipts, as will produce at all times General Receipts sufficient (i) to pay Debt Service Charges when due, (ii) together with other monies lawfully available therefor, to pay all costs and expenses required to be paid under the Bond proceedings, and (iii) together with other monies lawfully available therefor, to pay all other costs and expenses necessary for the proper maintenance and successful and continuous operation of the University.

(h) Payment, Places of Payment and Paying Agents. The principal of and any redemption premium on any Series 2003 A Bond when due shall be payable to the registered holder upon presentation and surrender thereof at the principal corporate trust office of the Trustee. Interest on Series 2003 A Bonds shall be payable by check or draft mailed by the Trustee as provided in the Indenture; provided, however, that interest on Series 2003 A Bonds aggregating \$1,000,000 or more in principal amount registered in the name of a single holder shall be paid by wire transfer in immediately available funds to such account, if any, as such holder directs in writing to the Trustee at least ten (10) days prior to any Interest Payment Date, such payment by wire transfer pursuant to that direction continuing in effect as to subsequent Interest Payment Dates until such time as the holder notifies the Trustee to the contrary or until such time as such holder ceases to be a holder of the requisite principal amount of Series 2003 A Bonds.

**AUTHORIZATION, ISSUANCE AND SALE OF
GENERAL RECEIPTS BONDS
SERIES 2003 A OF THE OHIO STATE UNIVERSITY (contd)**

(i) Book Entry. Subject to the provisions of the immediately following paragraph, the Series 2003 A Bonds shall be issued only to a Depository for holding in a Book Entry System. Those Series 2003 A Bonds shall be registered in the name of the Depository or its nominee, as registered owner, and immobilized in the custody of the Depository; and shall not be transferable or exchangeable, except for transfer to another Depository or to another nominee of a Depository, without further action by the University. Each maturity of the Series 2003 A Bonds shall be evidenced by a single certificate in the aggregate principal amount of the Series 2003 A Bonds maturing on each such maturity date.

If any Depository determines not to continue to act as a Depository for the Series 2003 A Bonds for holding in a Book Entry System, the University may attempt to have established a securities depository/Book Entry System relationship with another qualified Depository. If the University does not or is unable to do so, the University, after making provision for notification of the owners of book entry interests by appropriate notice to the then Depository and any other arrangements it deems necessary, shall permit the withdrawal of the Series 2003 A Bonds from the Depository, and authenticate and deliver the Series 2003 A Bond certificates, in fully registered form to the assigns of the Depository or its nominee (if such Bond was held by a nominee), all at the cost and expense (including costs of printing or otherwise preparing and delivering replacement Series 2003 A Bonds) of the University. Series 2003 A Bond certificates authenticated and delivered pursuant to this paragraph shall be in the denomination of \$5,000 or any integral multiple thereof.

Section 3. 2003 A Supplement; Contract of Purchase; Certificate of Award; Official Statement; Continuing Disclosure Agreement. To secure the pledge of General Receipts for the payment of Debt Service Charges on all Obligations, the execution, delivery and performance of the 2003 A Supplement in substantially the form on file with the Secretary of the Board is hereby approved and authorized. The Chairman, the President of the University, the Secretary of the Board and the Treasurer, or any one or more of them, are authorized and directed to execute and deliver to the Trustee, in the name and on behalf of the University such Amended and Restated Trust Indenture, with such changes therein as are not substantially adverse to the University and as may be permitted by the Act and approved by the officers executing the same on behalf of the University. Execution by the officer or officers of the University shall be conclusive evidence that any such changes are not substantially adverse to the University. The Treasurer of the University is directed and authorized to solicit, with such assistance from the Original Purchaser, the Trustee or others as he shall, in his sole reasonable discretion, deem necessary, the consent of the holders of a majority in principal amount of Obligations outstanding to the execution and delivery of the 2003 A Supplement.

The Series 2003 A Bonds are sold and awarded to the Original Purchaser in accordance with the Contract of Purchase at the purchase price provided in the Certificate of Award. The form of Contract of Purchase now on file with the Secretary of the Board is hereby approved, together with any changes therein and completions thereof which are not inconsistent with this Resolution and not substantially adverse to the University, and as are permitted by the Act and approved on behalf of the University by the Chairman or the Treasurer. The approval on behalf of the University of those changes and completions by the Chairman or the Treasurer, and the status of those changes as not substantially adverse to the University, shall be conclusively evidenced by the execution of the Contract of Purchase on behalf of the University by the Chairman or the Treasurer. It is determined hereby that the purchase price and the manner of sale and the terms of the Series 2003 A Bonds, as provided in this Resolution and the Contract of Purchase are consistent with all legal requirements and will carry out the public purposes of the Act.

The sale and award of the Series 2003 A Bonds shall be further evidenced by the Certificate of Award. The Certificate of Award is hereby authorized and shall be executed by the Chairman or the Treasurer. The Certificate of Award shall state or confirm the aggregate principal amount of the Series 2003 A Bonds, the purchase price of such Bonds, the interest rate or rates with respect to each maturity of such Bonds, and the optional redemption provisions, all as

**AUTHORIZATION, ISSUANCE AND SALE OF
GENERAL RECEIPTS BONDS
SERIES 2003 A OF THE OHIO STATE UNIVERSITY (contd)**

determined in accordance with the provisions of this Resolution and the Contract of Purchase, and all of which shall be conclusively evidenced by the execution of the Certificate of Award. The Certificate of Award shall also contain such other dates or provisions as the Chairman or the Treasurer determines are appropriate or necessary, and as are consistent with this Resolution, the Indenture, the 2003 A Supplement and the Contract of Purchase.

The use and distribution of the Offering Memorandum relating to the Series 2003 A Bonds by the Original Purchaser is hereby approve, authorized and ratified. The Offering Memorandum substantially in the form now on file with the Secretary of the Board, may be executed by the Chairman and the Treasurer or either of them, each in his official capacity on behalf of the University with any modifications, changes and supplements necessary or desirable for the purposes thereof which the Chairman or the Treasurer shall approve.

Section 4. Allocation of Proceeds. The proceeds from the sale of the Series 2003 A Bonds, including any accrued interest, shall be allocated, deposited and applied as follows:

(i) To the Debt Service Fund, accrued interest received on the sale of the Series 2003 A Bonds and the amount of proceeds of the Series 2003 A Bonds as specified by the Treasurer to currently refund the Refunded Bonds; and

(ii) To the Series 2003 A Issuance Expense Account, created pursuant to Section 5 of this Resolution, the amount of the proceeds of the Series 2003 A Bonds as specified in the Certificate of Award, and to pay costs and expenses associated with the issuance of the Series 2003 A Bonds.

Section 5. Series 2003 A Issuance Expense Account. There is hereby created by the University an account within the Facilities Fund to be maintained in the custody of the Treasurer and designated the "Series 2003 A Issuance Expense Account." The Series 2003 A Issuance Expense Account shall be funded from the proceeds of the sale of the Series 2003 A Bonds. Such proceeds shall be used for the payment of the costs and expenses associated with the issuance of the Series 2003 A Bonds. The Series 2001/2003 Project Account shall not constitute a Special Fund and shall not be pledged to the payment of Debt Service Charges.

The Treasurer shall maintain such books and records with respect to disbursements from the Series 2003 A Issuance Expense Account so as to enable the Treasurer to determine the name of any payee of any such disbursement, the date on which such disbursement occurred, the amount of such disbursement and the purpose for which such disbursement was made. Investment earnings on the funds on deposit in the Series 2003 A Issuance Account may, at the discretion of the University, be paid to the Trustee for deposit in the Bond Service Account in the Debt Service Fund to be used to pay Debt Service Charges on the Series 2003 A Bonds.

Section 6. Application of Bond Proceeds. The University covenants that the use of the proceeds of the Series 2003 A Bonds will be restricted in such manner and to such extent, if any, as may be necessary, after taking into account reasonable expectations at the time of delivery of and payment for the Series 2003 A Bonds, so that the Series 2003 A Bonds will not constitute arbitrage bonds under Sections 103(c) and 148 of the Code. The Treasurer of the University, or any other officer having responsibility with respect to the issuance of the Series 2003 A Bonds, alone or in conjunction with any other officer or employee of or consultant to the University, will give an appropriate certificate of the University for inclusion in the transcript of proceedings for the Series 2003 A Bonds setting forth the reasonable expectations of the University regarding the amount and use of all those proceeds and the facts and estimates on which they are based, all as of the date of original delivery of and payment for the Series 2003 A Bonds.

**AUTHORIZATION, ISSUANCE AND SALE OF
GENERAL RECEIPTS BONDS
SERIES 2003 A OF THE OHIO STATE UNIVERSITY (contd)**

The University further covenants that it will take all actions required to maintain the exclusion from gross income for purposes of federal income taxation of interest on the Series 2003 A Bonds, and will not take, nor permit to be taken, any actions which would adversely affect such exclusion under the provisions of the Code that apply to the Series 2003 A Bonds; and the Chairman or the Treasurer and other appropriate officers are hereby authorized to take such actions and give such certifications as may be appropriate to assure such exclusion from gross income of interest on the Series 2003 A Bonds.

Section 7. Call for Redemption of Refunded Bonds. The University hereby determines that the Refunded Bonds shall be called for optional redemption at the earliest date on which each of them may be redeemed pursuant to the Indenture and that the execution and delivery by the University of the 2003 A Supplement shall constitute the irrevocable direction to the Trustee to send such notices as are required by the Indenture to effect such call for redemption. The execution of the 2003 A Supplement and the acceptance of the estate conveyed thereby by the Trustee shall constitute the receipt by the Trustee of such direction and the agreement by the Trustee to give the aforementioned notices.

Section 8. Open Meeting Determination. It is found and determined that all formal actions of the Board concerning and relating to the adoption of this Resolution were adopted in an open meeting of the Board, and that all deliberations of the Board and of any of its committees that resulted in such formal action were in meetings open to the public, In compliance with all legal requirements including Section 121.22 of the Ohio Revised Code.

Section 9. Effective Date. This Resolution shall take effect and be in force immediately upon its adoption.

Upon motion of Mr. Sofia, seconded by Mr. McFerson, the Board of Trustees adopted the foregoing resolution with seven affirmative votes cast by Messrs. Sofia, Slane, and McFerson, and Judge Duncan, Mses. Longaberger, Hendricks, and Davidson, and two abstentions cast by Messrs. Patterson and Borrer.

--0--

Thereupon the Board adjourned to meet Wednesday, March 5, 2003, at The Ohio State University Longaberger Alumni House, Columbus, Ohio.

Attest:

David O. Frantz
Secretary

James F. Patterson
Chairman

(APPENDIX XXXII)

OSU BOARD OF TRUSTEES
February 7, 2003

TOPIC:

Long Term Resource Issues

CONTEXT:

At a time when growth in state support is small or decreasing, it is important to identify resources to meet academic goals without reliance on tuition increases alone.

The Academic Plan called for administrative cost reductions of \$3-5 million and non-traditional revenue increases of \$65-85 million in one-time funds for the FY 01 – FY06 time period. These goals will be met or exceeded in this time period; however, this still is not likely to be sufficient to meet our needs in the years ahead.

ISSUES:

- What have we learned from what we have done to date?
- What other revenue opportunities are there?
- What opportunities are there for cost reduction?
- How can we best organize to achieve these goals?

RECOMMENDATIONS:

- See attached materials.

REQUESTED OF BOARD OF TRUSTEES:

Discussion.

LESSONS LEARNED

- Our own benchmarking shows our costs are substantially below those of comparable institutions, but do not translate into diminished expectations from our students, from the community, or from the State of Ohio.
- OSU's size and diversity give us a comparative advantage to formulate unique sources of additional income and cost reduction.
- Achieving cost savings is a long-term continuous process, not a one-time big splash.
- The University needs to do a better job achieving and documenting Return on Investment on Systems installations and upgrades.
- Contracting out or bringing services in-house needs to be evaluated, but is not a panacea. Success varies depending on the characteristics of the services.
- Good business practices and good education practices are not inherently in conflict and should be mutually supporting.
- Competition for the best students, faculty and staff continues to intensify.
- Excellence does not come cheaply, but abundant resources do not assure excellence without discipline and focus.

A LONG RECORD

The University has a long record of innovative approaches to developing other revenue sources and achieving cost reductions.

Additional Revenue

- Increased Private Fund Raising since 1980's
- Charging non-general fund units for their share of support costs since 1980's
- Exclusive beverage and affinity card agreements since mid 1990's
- Tuition to market for graduate and professional programs since 1990's
- Significant surcharges for non-resident students since 1980's

Reduced Costs

- Managed Care and other benefits in 1990's
- Energy conservation and cost reduction since 1970's
- Hospital self insurance for malpractice since 1970's
- One of the handful of institutions in the country with a fully self-supported athletic program since 1980's
- Innovative measures to reduce borrowing costs in 1980's and 1990's
- Comprehensive restructuring of many academic units and programs in the early and mid 1990's

RECENT ACCOMPLISHMENTS

This process has intensified over the last two years.

Additional Revenue

- "Outside the box" initiative including changes in state law for non-endowment investments, new affinity card agreement and self funding for development
- Increased extramural sponsorship of research
- Increased cost recovery on federally sponsored research including salary recovery
- Restructured budget process to provide greater incentives to academic units to generate revenues and manage costs.

Reduced Costs

- Elimination of nearly 600 funded faculty and staff FTE positions in FY 2003
- Review of Central Commitments (Anderson Committee)
- Restructured Property and Liability Insurance
- Hedged natural gas prices with long term contracts
- Included web-based auction site to facilitate sale of surplus material

GOALS FOR THE NEXT 12 – 18 MONTHS

Areas of emphasis for the next 12-18 months:

Additional Revenues

- More aggressive federal agenda
- Increased extramural sponsorship of research
- Increase cost recovery rate on sponsored research including salary recovery and indirect cost recovery.
- Expand opportunities for private giving
- Selective program expansion, including distance learning
- Expand entrepreneurial partnerships where appropriate

**AREAS OF EMPHASIS FOR THE NEXT 12-18 MONTHS
REGARDING COST SAVINGS**

- 1. How can we gain improved performance from core administrative systems, such as, planning and construction of large capital projects and purchasing of goods and services?**

The Executive Deans have proposed a process to review all core administrative processes in order to improve service and reduce costs. We recommend that the first two processes to be reviewed be planning and construction of major capital projects (\$150M spent annually) and the university's three purchasing systems: central, hospitals and OSURF (\$500M annually).

- 2. How can we reduce the rate of increase in benefit costs while preserving access and quality for University faculty and staff?**

In the 1990's the university was able, through a managed care partnership with the OSU Medical Center, to provide OSU faculty and staff with high quality medical care at a reasonable cost. With health care costs back on an upward trend, it is time to examine new ways to reduce the rate of increase in the university's \$100M plus health insurance bill while preserving access to high quality care for university faculty and staff.

- 3. How can we take advantage of lower interest rates to lower our borrowing costs even further?**

Consumers have used low interest rates to refinance mortgages and reduce monthly payments. The university is in the position to do the same. The University Treasurer estimates this will save \$2.5 million over the next five years.

- 4. How can we use changes in energy markets to reduce our utility costs?**

At OSU, utility costs are \$37 million annually but are currently the lowest per student in the Big Ten. This competitive advantage will be more difficult to maintain in the future as competition makes markets more uniform nationally. This calls for a strategy that combines conservation, technology and competition to maintain our cost advantage in this area.

- 5. How can we use the lessons of the late 1990's to improve the Return of Investment of major administrative systems installations and upgrades?**

The university learned some painful lessons about what to do and what not to do in managing major system installations in the late 1990's. We need to make sure we use what we have learned from that experience in the next round of upgrades and installations. These are likely to cost \$10 to \$20 million annually for the next several years and we need to assure a maximum return on this investment.

NEXT STEPS

The academic planning and budget process cannot be just a discussion of how and more. It needs to also include revenue generation, cost reduction, resource allocation, and performance monitoring.

The following schedule is recommended to coincide with the FY 2004 budget process. One goal will be to identify at least \$20-25 million in additional cost savings or cost avoidance over the next five years:

April – Present more detailed recommendations for Board review based on the initiatives listed above including goals, priorities, assignments and timetables.

July – Approve final plans as part of FY 2004 budget

December – Mid-year progress report and regular reports thereafter

Summary and Conclusion

- Ohio State has established a good track record in managing its costs, but cannot afford to rest on past achievements.
- Additional opportunities exist for both revenue production and cost reduction.
- Success will not come easily; it will take time and commitment.
- Although more resources do not guarantee results, success in acquiring resources is critical to the success of the Academic Plan.
- Success also requires a firm base of tuition and state support.

**Waivers of Competitive Bidding Requirements
October-December 2002**

<u>Category</u>	<u>Total</u>	<u>Sole Source</u>	<u>Emergency</u>	<u>Sufficient Economic Reason</u>
Hospitals Merchandise for Resale	\$1,750,000	\$1,750,000	\$0	\$0
Hospitals - Professional Health Care Services	\$6,694,500	\$525,000	\$0	\$6,169,500
Hospitals - Equipment and Services	\$3,411,216	\$2,765,033	\$125,000	\$521,183
Merchandise For Resale	\$620,000	\$620,000	\$0	\$0
Instructional and Research Equipment and Services	\$2,841,707	\$1,594,342	\$0	\$1,247,365
Administrative Support Equipment and Services	\$1,894,809	\$593,298	\$108,385	\$1,193,126
TOTAL	\$17,212,232	\$7,847,673	\$233,385	\$9,131,174

(APPENDIX XXXIII)

**BOARD OF TRUSTEES
FISCAL AFFAIRS COMMITTEE
FEBRUARY 7, 2003**

TOPIC:

Second Quarter Financial Report

CONTEXT:

This is the second in a series of quarterly financial reports for FY 2002-03.

HIGHLIGHTS:

General Fund

- Summer, Autumn and Winter Quarter Enrollments were about as projected but the composition was different (Attachment A)
 - Total enrollments are up slightly (0.6%) but nonresident enrollments are down 2.2%.
 - Financial impact on tuition revenue is negligible.
- State Support may increase \$2.3 million over our Spring estimates based on preliminary projections provided by the Board of Regents; however,
 - Statewide Board of Regents appropriations (excluding state share of instruction, debt service and National Guard Tuition Assistance) were cut by the Governor's January 22 Executive Order to Reduce Spending by \$13.4 million or 2.5%. Detailed figures as to how the cut will impact Ohio State have not yet been received from the Board of Regents but are expected shortly. A 2.5% reduction of Ohio State's non-state share of instruction line items for all campuses would equal \$2.8 million.
 - Reduction of the state share of instruction by 2.5% is possible if the Governor's budget balancing proposal is not adopted.
 - Academic and academic support units have been advised of the approved and possible reductions and instructed to plan accordingly. Additional information and recommended adjustments will be provided at the March 5 Board of Trustees meeting.
 - Due to continued uncertainty over the economy and the State budget picture, we recommend no change in the University's budget projections until third quarter.
- Indirect Cost Recoveries are higher than projected
 - Through the Second quarter, Indirect Cost Recoveries are 10.0% higher than in FY 2002 compared to a 3.5% projected increase. An additional 3.5% (1.8M) increase is recommended at this time with a corresponding distribution of budget to the colleges.

Non-General Fund

- Ohio State University Health System financial results are better than budget and last year (Attachment B)
 - First six months shows a \$2.1 million gain compared to
 - Minus \$5.3 million first half actual last year
 - Minus \$1.9 million first half budget target this year

- Recent actuarial reports noted that the Hospital Self Insurance Fund had discounted liabilities of \$21.7 million and that Oval Ltd., the University's captive insurance company, had discounted liabilities of \$2.4 million. The market value of the Self Insurance Fund as of December 2002 was \$19.8 million and of Oval Ltd. was approximately \$3.4 million. The Hospital Self Insurance Committee approved recommendations for FY 2003 to contribute an additional \$3.4 million to the Self Insurance Fund, \$0.6 million to Oval Ltd. and an additional \$0.5 million to Oval Ltd.'s capital.
- Auxiliaries
 - Athletics operating revenue and expense are within budget. Net operations are positive and slightly better than last year as a result of bowl related revenue.
 - Schottenstein Center: Mid-year revenue is significantly ahead of last year with corresponding expense also increasing, but to a lesser degree. Net operations are again positive and ahead of both budget and last year's actual.
 - Blackwell Inn: The Blackwell Inn has been open for only six months, so results are preliminary. Total revenue is meeting budget targets for year to date and customer service ratings are excellent. Food and beverage revenues are higher than anticipated. Occupancy is lower than projected and some expenses are higher. Consequently, net income is less than expected. Management is initiating changes to increase occupancy and to reduce expenses in order to achieve the goals of making this facility self-supporting.

RECOMMENDATION:

Approval of the attached resolution.

Attachment A

Headcount Enrollments
Summer and Autumn 2002 and Winter 2003

Category	Projected¹	Actual²	Difference	%
Undergraduate	82,884	83,723	+839	+1.0%
Graduate	26,996	26,772	-224	-0.8%
Professional	7,033	7,106	+73	+1.0%
Total	116,913	117,601	+688	+0.6%

NOTE: Includes total of Summer, Autumn and Winter Quarters

SOURCE: Resource Planning

¹ Projected in May for FY 2003 budget

² Reflects 14th day enrollment counts

The Ohio State University Health System
Financial Summary

YTD Ending December 31, 2002
(In Thousands)

Category	Actual 2003	Budget 2003	Actual 2002
Net Patient Revenue	\$ 364,627	\$ 368,276	\$ 322,309
Other Income	37,436	35,765	16,592
Total Income	402,063	404,041	338,901
Expenses	399,953	405,964	344,196
Revenue over Expenses	\$ 2,110	\$ (1,923)	\$ (5,295)

SOURCE: The Ohio State University Health System
Prepared January 15, 2003

SUMMARY OF BUDGETED RESOURCES AND EXPENDITURES
FY 2003 SECOND QUARTER BUDGET REPORT
(In Thousands)

	Original Budget		2nd. Quarter Budget Revision		Difference	
	General Funds	Other Funds Total	General Funds	Other Funds Total	General Funds	Other Funds Total
Resources						
State Subsidy & Appropriations	348,012	92,969 440,981	348,012	92,969 440,981	0	0 0
Student Fees	447,082	9,029 456,111	447,082	9,029 456,111	0	0 0
Gifts, Grants & Contracts	55,270	459,628 514,898	57,070	463,428 520,498	1,800	3,800 5,600 (1)
Health System		828,517 828,517		828,517 828,517	0	0 0
Auxiliaries		188,217 188,217		188,217 188,217	0	0 0
Other Income	22,753	96,761 119,514	22,753	96,761 119,514	0	0 0
Total Resources	873,117	1,675,121 2,548,238	874,917	1,678,921 2,553,838	1,800	3,800 5,600
Expenditures						
Education & General	872,728	645,459 1,518,187	874,528	649,259 1,523,787	1,800	3,800 5,600 (2)
Health System		831,626 831,626		831,626 831,626	0	0 0
Auxiliaries		196,539 196,539		196,539 196,539	0	0 0
Total Expenditures	872,728	1,673,624 2,546,352	874,528	1,677,424 2,551,952	1,800	3,800 5,600
Net	389	1,497 1,886	389	1,497 1,886	0	0 0

(1) General Funds: An additional 3.5% increase (\$1.8M) in indirect cost recoveries based on activity to date.

Other Funds: A corresponding increase (\$3.8M) in Grants and Contracts based on activity to date.

(2) General Funds: A distribution of the additional \$1.8M in indirect cost recoveries to the colleges generating the increase in research activity.

Other Funds: A corresponding increase (\$3.8M) in restricted expenditures that generated the increase in Grants and Contracts.

**The Ohio State University Board of Trustees
Fiscal Affairs Committee
February 7, 2003**

TOPIC:

Budget versus Actual Report for FY 2001-02

CONTEXT:

- This is an annual report on the differences between budgeted and actual revenues and expenditures at the Columbus Campus for Fiscal Year 2002.
- This report was first provided to the Board five years ago in order to ensure appropriate financial accountability.
- The FY 2002 report format is consistent with fund accounting but does not represent the new GASB standards. The formatting of the report will change in FY 2003 to reflect the new accounting standards and include the total University revenues and expenditures.

SUMMARY:

- The records of the University budget and accounting system are reconciled.
- The targets used by the Office of Business and Finance to project resources and expenses are to project within +/- 1% of actual General Fund resources and expenses, within +/- 5% of Earnings and within +/- 10% of Restricted.
 - FY 02 revised budget was within 1.7% of actual General Fund resources primarily as a result of grants and contracts exceeding estimates. General Fund expenditures were 4.65% lower than budget primarily as a result of the University intentionally spending less than budgeted in order to absorb state budget cuts. This is higher than the targets but appropriate given the unusual circumstance of this budget cycle.
 - Resources and expenditures for earnings units were within the 5% target.
 - Restricted resources and expenditures were slightly higher than the target with actual exceeding estimates by over 10.5% due to an increase in state, private and federal grants and contracts. Resource Planning will be working with the colleges to improve our estimating process in this area.

ACTION REQUESTED OF FISCAL AFFAIRS COMMITTEE:

Recommend Board of Trustees adoption of resolution.

Office of Business and Finance
Resource planning
February 4, 2003

THE OHIO STATE UNIVERSITY
COMPARISON OF BUDGET TO ACTUAL
COLUMBUS CAMPUS FOR FY 2002
(In Thousands)

	General Funds			Earnings			Restricted		
	Revised Budget	Actual	% Variance	Revised Budget	Actual	% Variance	Revised Budget	Actual	% Variance
Resources									
State Subsidy & Appropriations	322,577	323,294	0.22%				56,447	57,995	2.74%
Student Fees	375,152	379,581	1.18%	7,800	4,541	-41.78% (5)			
Gifts, Grants & Contracts	57,297	63,461	10.76% (1)				372,500	438,517	17.72% (9)
Health System				725,040	715,483	-1.32%			
Auxiliaries				169,975	150,854	-11.25% (6)			
Other Income	23,236	25,171	8.33% (2)	67,700	72,732	7.43% (7)	33,000	14,145	-57.14% (10)
Total Resources	778,262	791,507	1.70%	970,515	943,610	-2.77%	461,947	510,657	10.54%
Expenditures									
Education and General									
Health System	788,332	751,694	-4.65% (3)	78,527	89,508	13.98% (8)	440,907	486,307	10.30% (11)
Auxiliaries				719,629	694,298	-3.52%	13,240	13,049	-1.44%
				168,021	151,913	-9.59% (6)	7,800	11,301	44.88% (12)
Total Expenditures	788,332	751,694	-4.65% (4)	966,177	935,719	-3.15%	461,947	510,657	10.54%

Notes:

General Funds:

- (1) State grants and contracts were up 32% over the budgeted estimate and federal grants and contracts were approximately 8% higher.
- (2) Partially due to actual investment income exceeding budget by 1.1 million.
- (3) For purposes of this presentation General Funds support to Auxiliaries are consolidated with Education and General expenditures.
- (4) Budget reflects a one time spend down of the Rainy Day fund that will be replenished in FY 03. Actual spending is lower because of the uncertainty of the budget situation in FY 02.

Earnings:

- (5) Actual earnings from conference fees continue to be down. This situation will be monitored and an adjustment made to FY 03.
- (6) Actual Earnings appear lower than budget for auxiliaries partly due to actual financials not reflecting intrauniversity transfers. These data are included in the budget numbers.
- (7) Primarily due to 11.6 million in Investment and Other Sources not included in the budget.
- (8) Actual Education and General includes a net interfund transfer of \$5 million from General Funds into earnings which is causing an overstatement of Earnings Education and General expenditures. Budget has trailed actual in recent years and will be adjusted in FY 03.

Restricted:

- We do not budget for restricted activity. It is an estimate based on prior-year trends.*
- (9) State grants and contracts were up 32% over the budgeted estimate and federal grants and contracts were approximately 8% higher.
 - (10) Partly due to the transfer of endowment income into restricted funds in a prior year. Budget was adjusted in FY 03.
 - (11) Institutional Support and Operation of Plant and Maintenance expenditures were both significantly higher than in previous years as a result of increased research. Adjustments will be made in FY 03.
 - (12) The budget includes Athletics grants-in-aid only while Actual includes other restricted expenses including Schottenstein Suites, bowl expenses, Athletics Discretion, Stadium Brick project and NCAA Youth Program.

*Note that the presentation is consistent with fund accounting and does not represent new GASB standards. The formatting of the report will change in FY 03.



Marion Campus - Student Housing

315-2001-926

Requesting Agency(s): STUDENT AFFAIRS, OFFICE OF

Location(s): Site - See Comments.

Gross Sq. Ft.0 Age:

Description: Design and construct a facility to provide on-campus student housing which is proposed to include 4-person suites including bathrooms and kitchens, common living areas, main lobby, recreation room, computer center, classrooms, support offices and apartments, parking, and laundry on the Marion Campus.

Project Team:

Facility Planner: Cheryl Christle
(christle.2@osu.edu)

Project Captain: Craig Henry
(henry.194@osu.edu)

Project Assistant: Curt Handschug
(handschug.1@osu.edu)

Field Coordinator: Is Unassigned

Project Information:

Authorization to employ a construction manager requested at the November 2, 2001 Board of Trustees meeting.

Site to be east of the drainage creek and south of the existing parking lots.

Original estimate was for 160 beds and 48,833 gross square feet, revised estimate is for 300 beds and approx. 102,242 gross square feet.

Source of Funds:	Original	Revised	Uses of Funds:	As Designed	As Bid	Completion
Future Univ. Bond Issues	\$7,045,753.00	\$16,604,081.00				
Total:	\$7,045,753.00	\$16,604,081.00	Total:			

Schedule:	Projected	Revised	Actual
Planning			
Arch/Engr Approved by B/T (\$16,604,081 Project)	02/07/2003		
Arch/Engr Approved by B/T (\$7,045,753 Project)	11/02/2001		11/02/2001
Constr Mgr Approved by B/T (\$16,604,081 Project)	02/07/2003		
Constr Mgr Approved by B/T (\$7,045,753 Project)			11/02/2001
Bidding Approved B/T	09/06/2002	07/11/2003	
Design			
Arch/Engr Contract	02/28/2002	12/31/2002	12/20/2002

Marion Student Housing

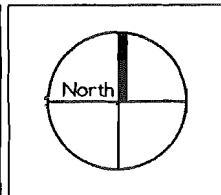
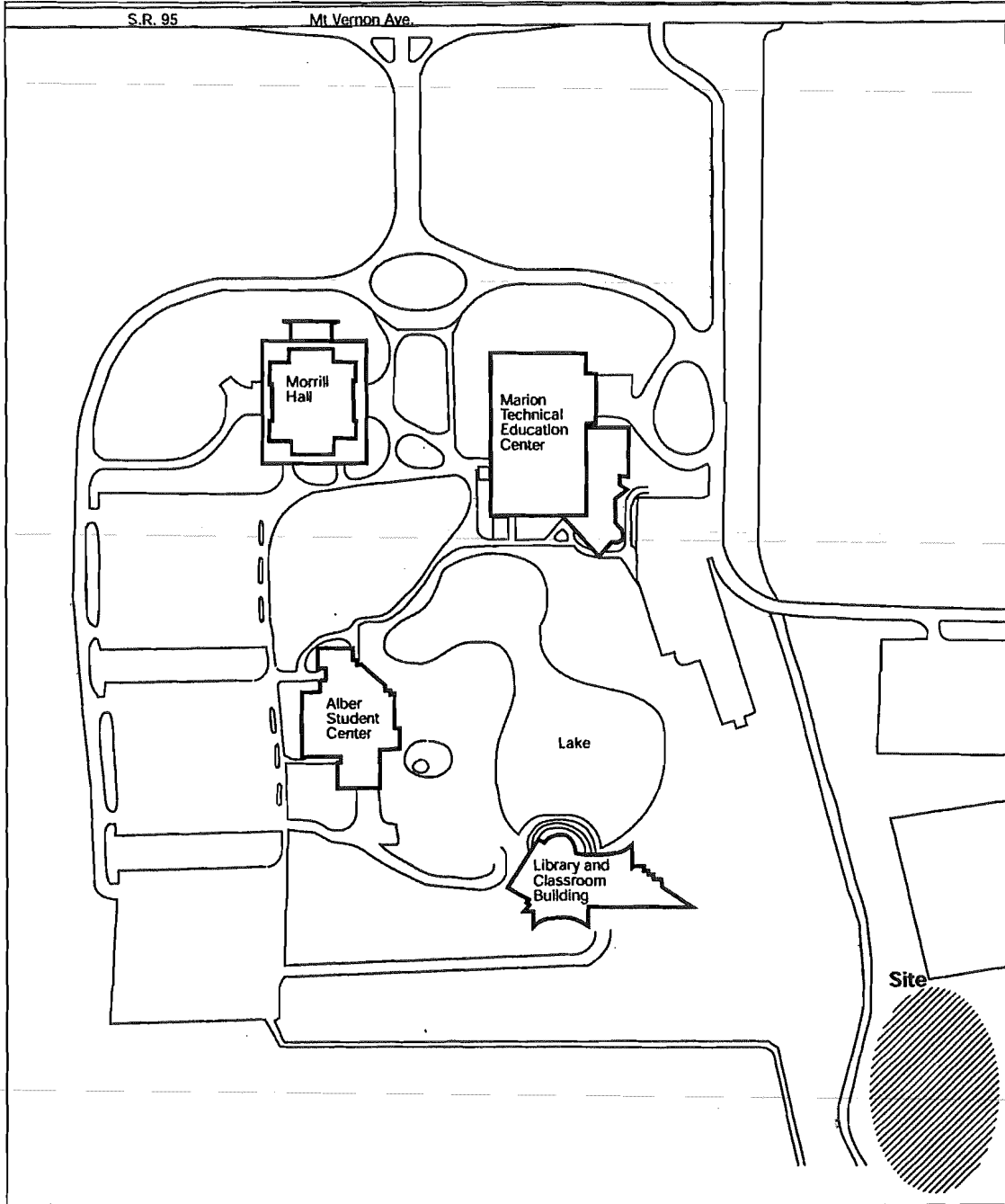

Office of Business and Finance
Office of the University Architect and Physical Planning

October 12, 2001



Requesting Agency(s): STUDENT AFFAIRS, OFFICE OF

Location(s): Site - See Comments.

Gross Sq. Ft.0 Age:

Description: Provide on-campus student housing. The primary design consists of 4 person suites including bathrooms and kitchens, common living areas, main lobby, recreations room, computer center, classrooms, support office/apartments, parking and laundry.

Project Team:

Facility Planner: Teresa Yu
(yu.195@osu.edu)
Project Captain: Craig Henry
(henry.194@osu.edu)
Project Assistant: Andrea Thimmes
(thimmes.5@osu.edu)
Field Coordinator: Is Unassigned

Project Information:

The project reflects costs in 2003 dollars.
Original estimate was for 150 beds, revised estimate is for 300 beds.

Source of Funds:	Original	Revised	Uses of Funds:	As Designed	As Bid	Completion
Future Univ. Bond Issues	\$9,300,000.00	\$16,604,081.00				
Total:	\$9,300,000.00	\$16,604,081.00	Total:			

Schedule:	Projected	Revised	Actual
Planning			
Arch/Engr Approved by B/T (\$16,604,081 Project)	02/07/2003		
Arch/Engr Approved by B/T (\$9,300,000 Project)	08/29/2001		08/29/2001
Constr Mgr Approved by B/T (\$16,604,081 Project)	02/07/2003		
Constr Mgr Approved by B/T (\$9,300,000 Project)	08/29/2001		08/29/2001
Bidding Approved B/T	05/05/2002	07/11/2003	
Design			
Arch/Engr Contract	10/14/2001	06/12/2003	07/03/2002

Lima Campus - Student Housing

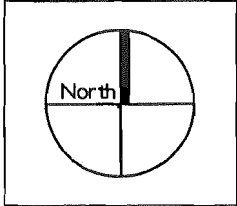
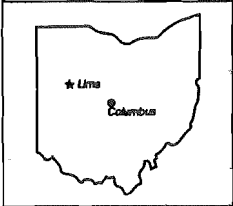
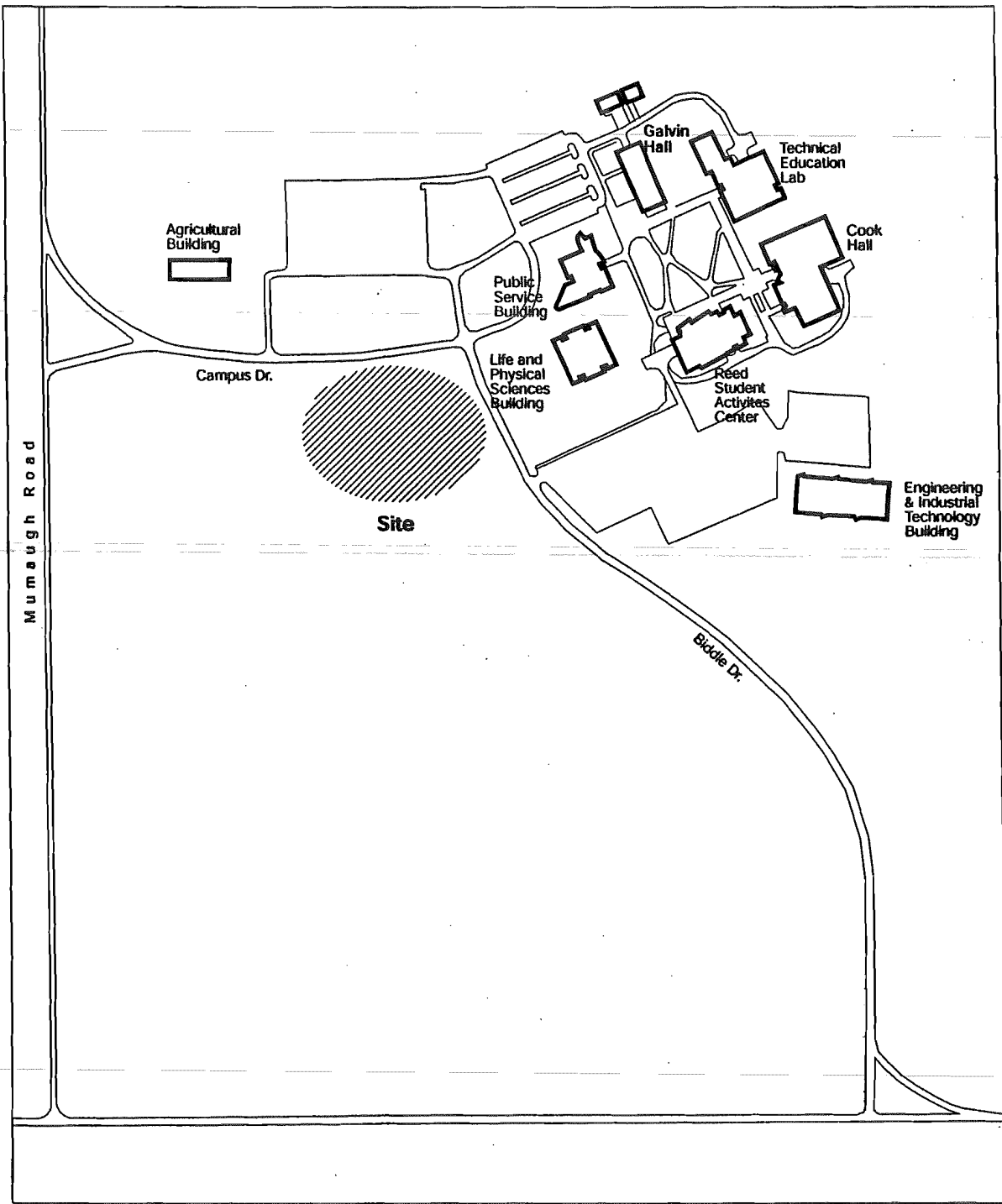

Office of Business and Finance
Office of Facilities Planning and Development

August 7, 2001



Marion Campus - Student Services Building
315-2001-930

Requesting Agency(s): MARION CAMPUS

Location(s): Site - See Comments.

Gross Sq. Ft.0 Age:

Description: Construct a two story, concrete and masonry, administrative structure of approximately 17,500 square feet that will house the expanded student services of the Marion Campus. These will include admissions, advising, financial aid, registrar services, fee payment, career services, disability services, Master of Social Work Program and Nursing Program.

Project Team:

Facility Planner: Anne Pensyl
(pensyl.3@osu.edu)
Project Captain: Marty Bricker
Project Assistant: Steve Deedrick
(deedrick.4@osu.edu)
Field Coordinator: Is Unassigned

Project Information:

Selected site is on the parking lot between Alber Student Center and Morrill Hall.
Original project budget of \$3,730,169 approved by the Board of Trustees on December 6, 2001. Project budget increased to reflect the scope change to approximately 30,000 square feet to reflect the increased enrollment on the Marion Campus and the inclusion of the Alber Center (currently housed in lease space) and security services not currently on the Marion Campus.

Source of Funds:	Original	Revised	Uses of Funds:	As Designed	As Bid	Completion
General Funds-Marion	\$1,266,119.00	\$3,088,006.00	Total:			
Treasurer's Debt Service	\$1,100,000.00	\$1,100,000.00				
Pool Loan						
HB640 Line Item	\$1,364,050.00	\$1,364,050.00				
Appropriation						
Total:	\$3,730,169.00	\$5,552,056.00				

Schedule:

	Projected	Revised	Actual
Planning			
Arch/Engr Approved by B/T (\$3,730,169 Project)	12/06/2001		12/06/2001
Arch/Engr Approved by B/T (\$5,552,056 Project)	02/07/2003		
Bidding Approved B/T (\$3,730,169 Project)	12/06/2001	03/30/2003	12/06/2001
Bidding Approved B/T	06/06/2003		
Design			
Arch/Engr Contract	01/30/2002	11/25/2002	11/26/2002
Schematic Design Approval	04/01/2002	07/30/2002	09/19/2002
Design Dev Document Approval	10/01/2002	11/25/2002	12/26/2002

Marion Campus Student Services Building

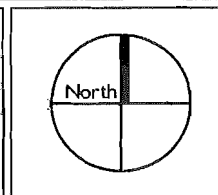
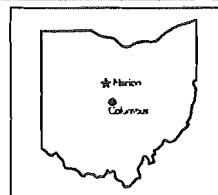
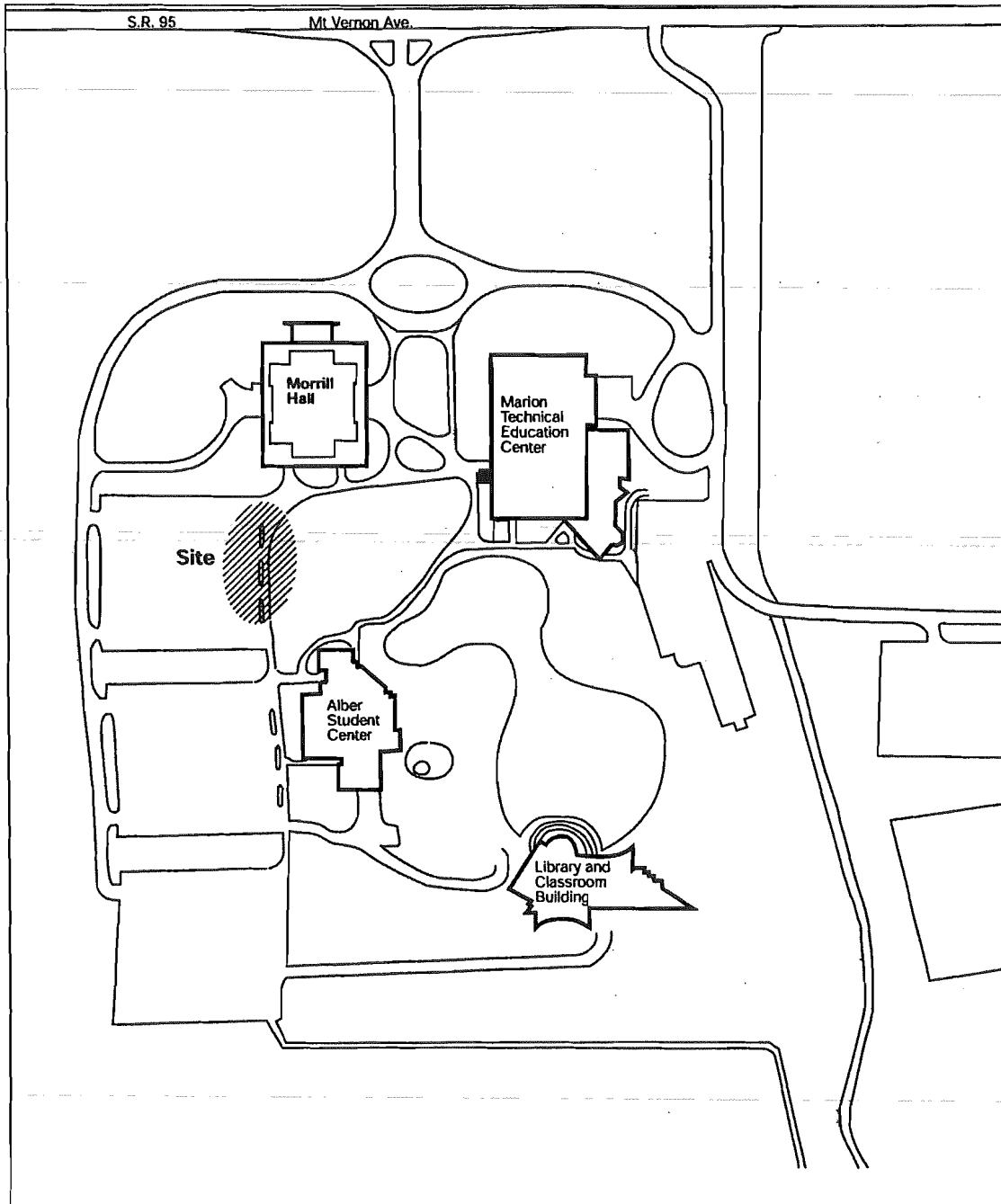

Office of Business and Finance
Office of the University Architect and Physical Planning

November 14, 2001



Veterinary Hospital - Student Lounge Renovation

315-2002-934

Requesting Agency(s): VETERINARY MEDICINE ADMINISTRATION

Location(s): VETERINARY HOSPITAL

Gross Sq. Ft. 222,496 Age: 1973

Description: Construct student lounge area within current Room 0005, including appropriate changes to lighting, electrical and HVAC, and all associated furniture and decorative items and services.

Project Team:

Facility Planner: Is Unassigned

Project Captain: Carolyn Kotterman
(kotterman.3@osu.edu)

Project Assistant: Karen Cogley
(cogley.1@osu.edu)

Field Coordinator: Is Unassigned

Project Information:

Formerly known as 50700-R021680

Source of Funds:	Original	Revised	Uses of Funds:	As Designed	As Bid	Completion
Development-Veterinary Medicine	\$199,999.00	\$253,583.00				
Total:	\$199,999.00	\$253,583.00	Total:			

Schedule:

	Projected	Revised	Actual
Planning			
Bidding Approved B/T (\$253,583 Project)	02/07/2003		
Design			
Schematic Design Approval	11/13/2002		11/15/2002
Design Dev Document Approval	12/18/2002		12/20/2002
Construction Document Approval			12/20/2002
Bidding			
Bid Opening	03/18/2003		

Veterinary Hospital - Student Lounge Renovation

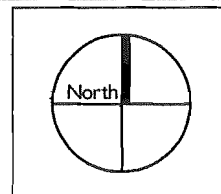
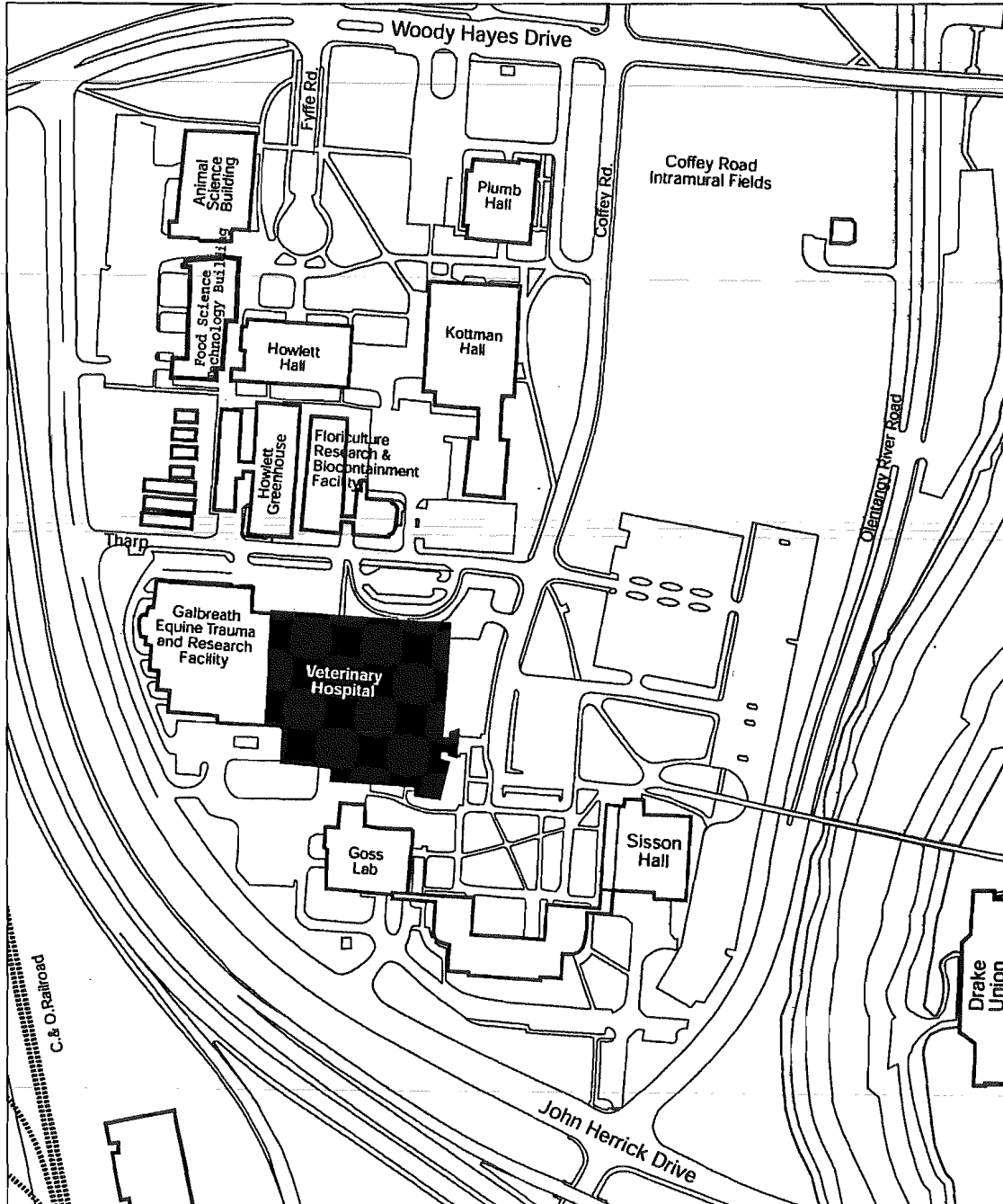

Office of Business and Finance
Office of Facilities Planning and Development

January 13, 2002



Airport Pavement Rehabilitation/Extension - Phase I

315-2002-931

Requesting Agency(s): ENGINEERING ADMINISTRATION

Location(s): Various Locations-Franklin County

Gross Sq. Ft.0 Age:

Description: This project includes rehab of all existing runways, taxiways and aprons, as well as extending the North Runway (9L/27R), Taxi Way "G" and two new taxi ways that will connect both North Runway (9L/27R) and South Runway (9R/27L). The project is planned into two phases in order to minimize the disruption of airport operations. In particular, Phase I will extend R/W 9L/27R West Portion, T/W G West Portion and new West End T/W and rehab R/W 5/32, T/W "C", "G", and "H". Phase II will extend R/W 9L/27R East Portion, T/W "G" East Portion, and new East End T/W and rehab R/W 9L/ 27R and 9R/27L, T/W "A", "B", "D" and Apron.

Project Team:

Project Information:

Facility Planner: Is Unassigned
 Project Captain: Bo Zhang
 (zhang.403@osu.edu)
 Project Assistant: Steve Deedrick
 (deedrick.4@osu.edu)
 Field Coordinator: Is Unassigned

Source of Funds:	Original	Revised	Uses of Funds:	As Designed	As Bid	Completion
Development-Engineering	\$840,000.00	\$840,000.00				
Grant-Federal Aviation Association	\$7,560,000.00	\$7,560,000.00	Total:			
Total:	\$8,400,000.00	\$8,400,000.00				

Schedule:

Projected

Revised

Actual

Planning
 Arch/Engr Approved by B/T (\$8,400,000 Project)

02/07/2003

Airport Pavement Rehabilitation/Extension - Phase I

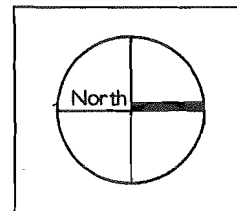
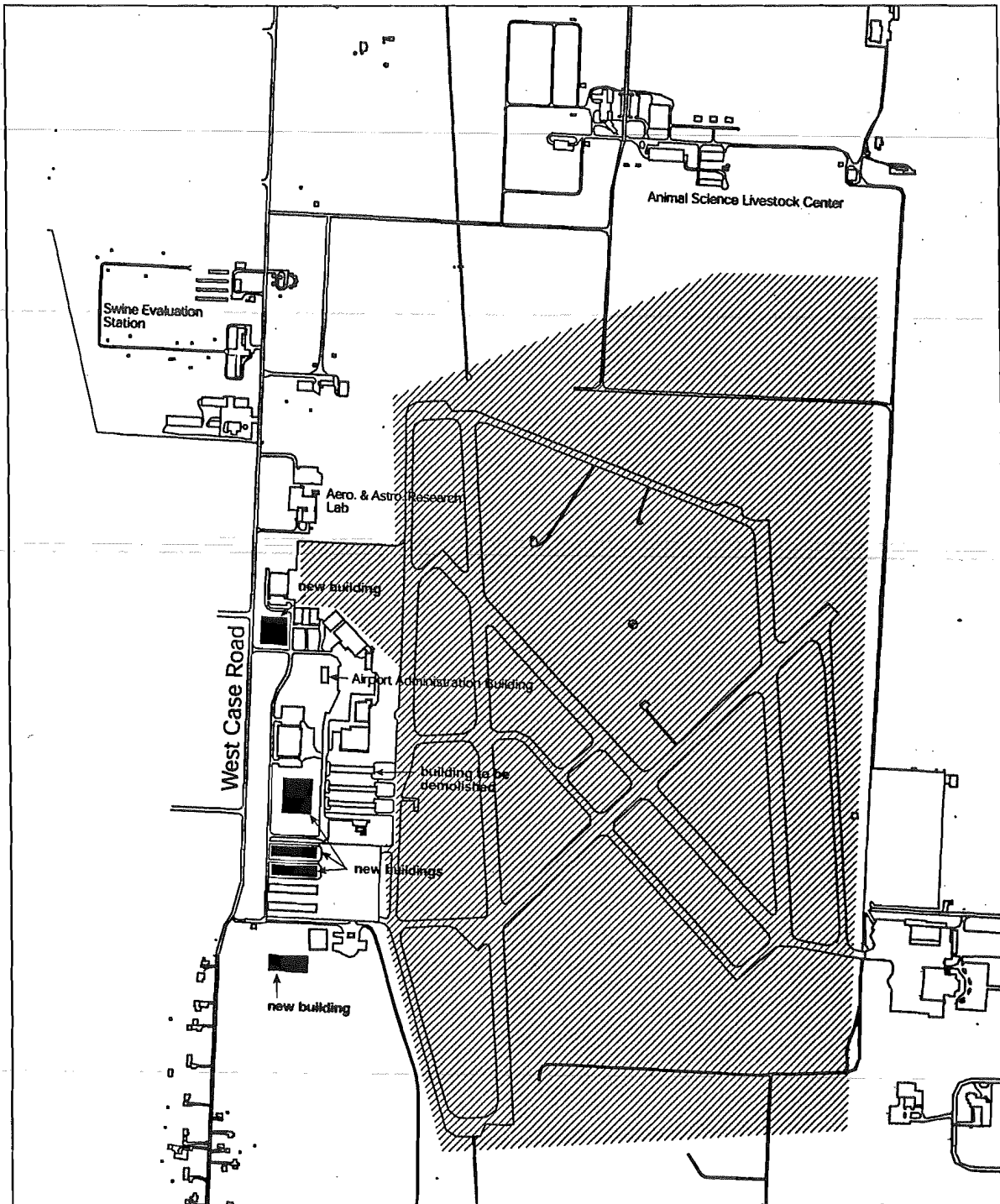

Office of Business and Finance
Office of Facilities Planning and Development

January 14, 2003



Requesting Agency(s): ATHLETICS

Location(s): Site - See Comments.

Gross Sq. Ft.0 Age:

Description: Install Musco sports lighting; maintained footcandles 100/80

Project Team:

Facility Planner: Is Unassigned

Project Captain: Thomas Heretta
(heretta.1@osu.edu)
Project Assistant: Curt Handschug
(handschug.1@osu.edu)
Field Coordinator: Is Unassigned

Project Information:

Formerly known as 50700-R021700

Source of Funds:	Original	Revised	Uses of Funds:	As Designed	As Bid	Completion
Auxiliaries-Athletics	\$349,994.00	\$349,994.00				
Total:	\$349,994.00	\$349,994.00	Total:			

Schedule:

	Projected	Revised	Actual
Planning Bidding Approved B/T (\$349,994 Project)	02/07/2003		

Softball Stadium Sports Lighting

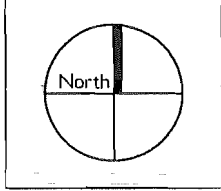
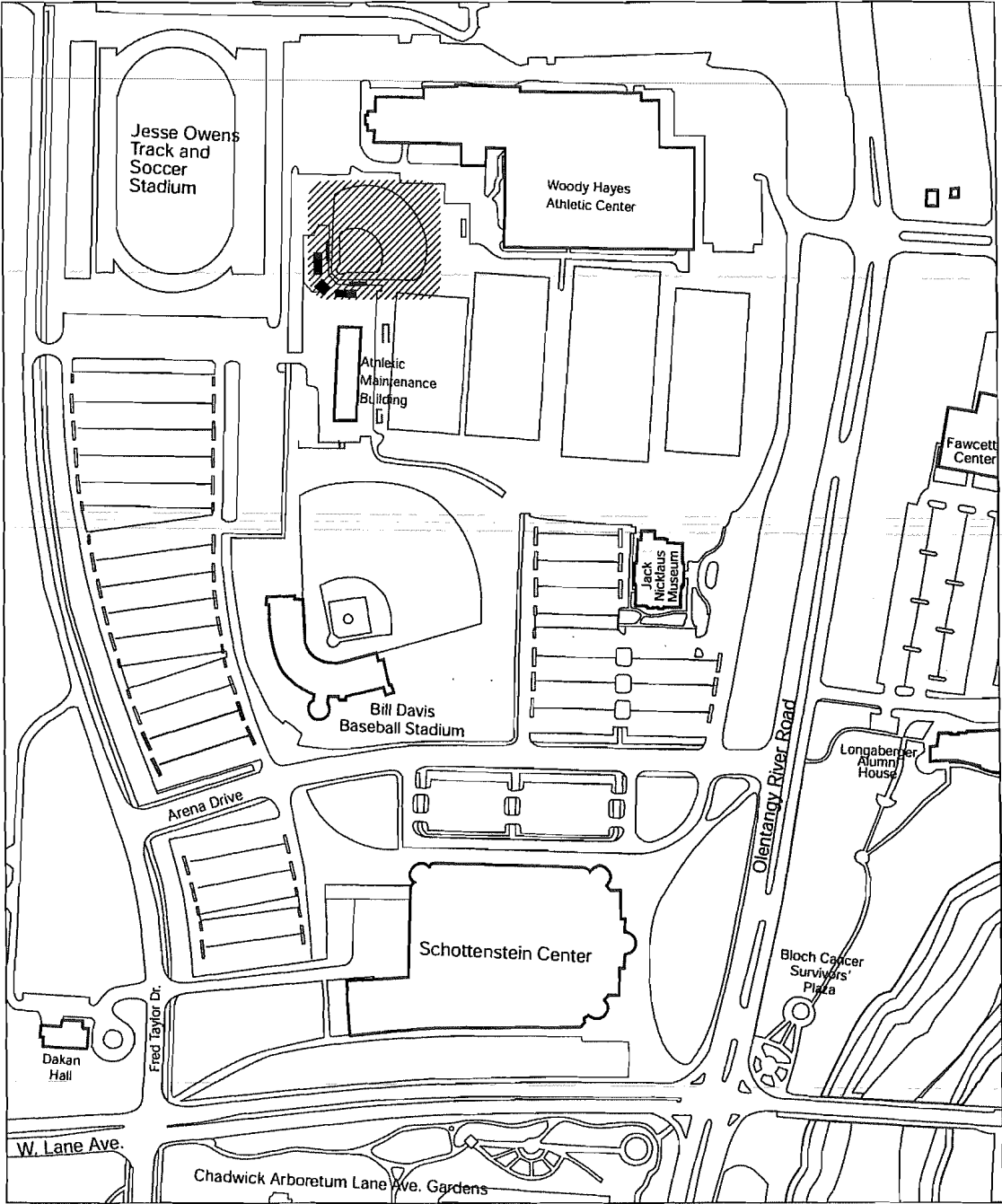

Office of Business and Finance
Office of Facilities Planning and Development

January 14, 2003



Campbell Hall, University Hall & Evans Lab Renov.

315-2002-908

Requesting Agency(s): MATHEMATICAL & PHYSICAL SCIENCES ADMIN

Location(s): Various Locations-Columbus

Gross Sq. Ft.0 Age:

Description: Renovate classrooms 200 in Campbell Hall and 014 in University Hall to improve the quality of the teaching and learning facilities and to renovate large lecture room 108 in Evans Lab.

Project Team:

Facility Planner: Teresa Yu
(yu.195@osu.edu)
Project Captain: Jack Bargaheiser
(bargaheiser.2@osu.edu)
Project Assistant: Mikki Reese
(reese.153@osu.edu)
Field Coordinator: Jack Bargaheiser
(bargaheiser.2@osu.edu)

Project Information:

Two projects were combined into one (315-2000-953 - Campbell & University Halls Classrooms & 315-2000-956 Evans Laboratory Lecture Room Renovation). The actual milestone date for BOT approval for Arch/ Eng & Bidding was used from the Campbell & University Halls Classrooms project

Source of Funds:	Original	Revised	Uses of Funds:	As Designed	As Bid	Completion
HB790 Columbus Suppl. Renov	\$230,530.00	\$230,530.00	Total:			
HB904 Columbus Basic Renovation	\$0.00	\$18,880.00				
HB808 Columbus Basic Renovation	\$0.00	\$18,850.00				
HB810 Columbus Line Items	\$0.00	\$72,873.92				
HB748 Columbus Basic Renovation	\$0.00	\$42,942.00				
HB748 Columbus ADA Modifications	\$0.00	\$133,282.00				
HB850 Columbus Basic Renovation	\$0.00	\$50,826.08				
HB640 Basic Renovations	\$1,512,000.00	\$1,512,000.00				
Total:	\$1,742,530.00	\$2,080,184.00				

Schedule:	Projected	Revised	Actual
Planning			
Arch/Engr Approved by B/T (\$1,742,530 Project)	04/06/2001		07/06/2002
Bidding Approved B/T (\$2,080,184 Project)	04/06/2001	02/11/2003	
Design			
Arch/Engr Contract	07/31/2002	01/20/2003	
Schematic Design Approval (University Hall)	11/29/2002	09/30/2002	10/17/2002
Design Dev Document Approval (University Hall)	03/28/2003	10/11/2002	10/17/2002
Construction Document Approval (University Hall)	07/31/2003	11/26/2002	11/26/2002
Bidding			
Bid Opening (University Hall)	08/28/2003	02/07/2003	

Campbell Hall, University Hall and Evans Lab Renovation

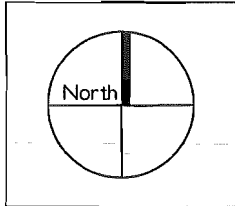
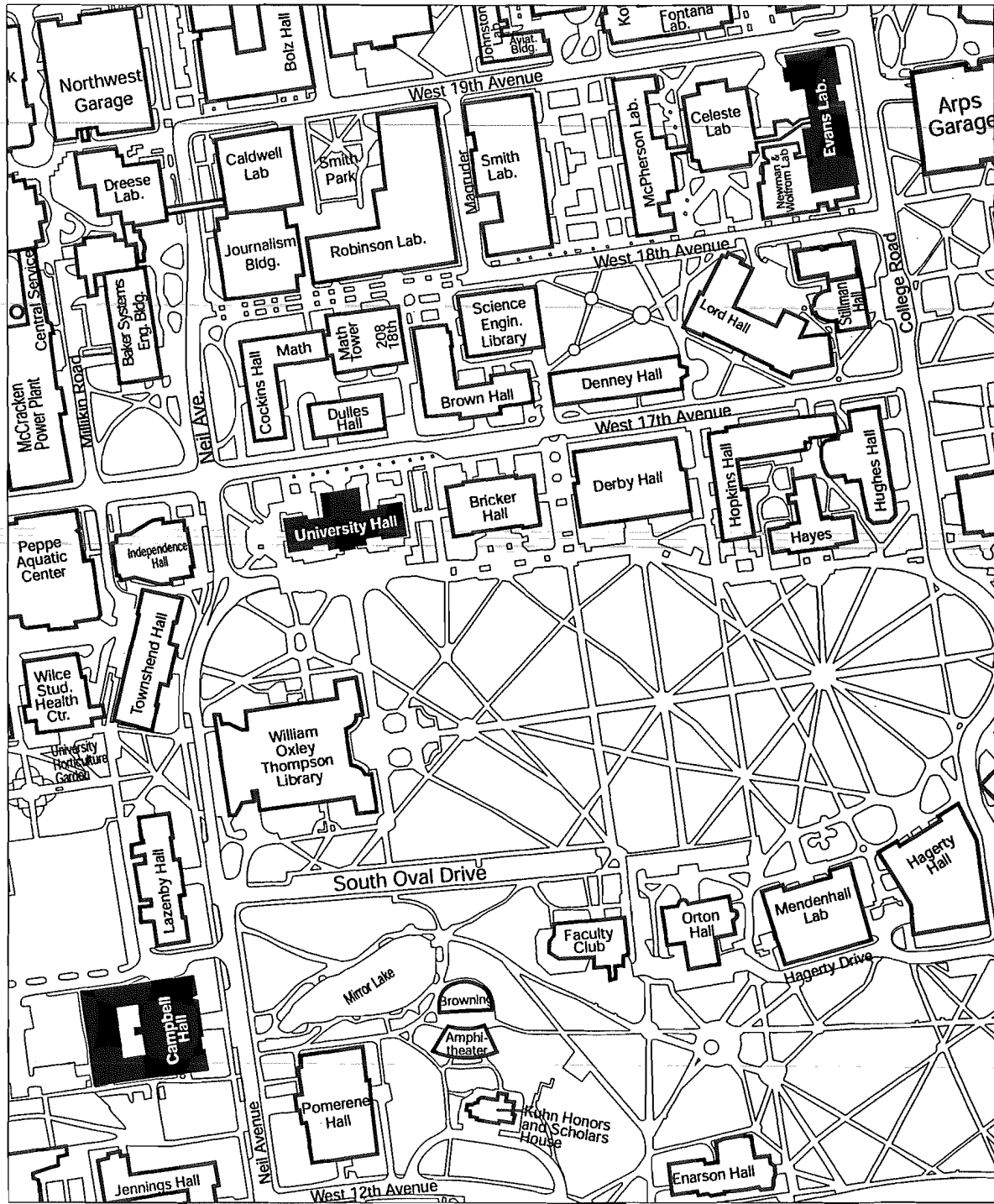

Office of Business and Finance
Office of Facilities Planning and Development

January 15, 2003



Lima Campus - Reed Hall Theatre Addition

315-2000-904

Requesting Agency(s): LIMA CAMPUS

Location(s): REED STUDENT ACTIVITIES BLDG

Gross Sq. Ft.29,995 Age: 1968

Description: Provide an addition to Reed Hall to provide enhanced facilities for the Theatre Program. The stage in the existing auditorium will be expanded with backstage areas for complete theatre productions made from remodeled existing space. The added areas include rehearsal space, technical space, dressing rooms, green room, restrooms, seminar/classrooms, and public space.

Project Team:

Facility Planner: Is Unassigned

Project Captain: Christine Lawson
(lawson.132@osu.edu)

Project Assistant: Steve Deedrick
(deedrick.4@osu.edu)

Field Coordinator: Is Unassigned

Project Information:

Project budget of \$1 million approved at the October 6, 2000 meeting. Project budget increased to reflect the addition of an art gallery and increased square footage.

Source of Funds:	Original	Revised	Uses of Funds:	As Designed	As Bid	Completion
Development-Lima	\$1,000,000.00	\$1,600,000.00				
Total:	\$1,000,000.00	\$1,600,000.00	Total:			

Schedule:

	Projected	Revised	Actual
Planning			
Arch/Engr Approved by B/T (\$1,000,000 Project)	10/06/2000		10/06/2000
Bidding Approved B/T (\$1,600,000 Project)	10/06/2000	02/07/2003	
Design			
Arch/Engr Contract	01/15/2001	10/03/2001	10/03/2001
Schematic Design Approval	04/15/2001	08/15/2001	08/06/2001
Design Dev Document Approval	09/15/2001	01/15/2002	01/24/2002
Construction Document Approval	01/15/2002	08/01/2002	08/20/2002
Bidding			
Bid Opening	03/15/2002	02/13/2003	

Lima Campus - Reed Hall Theatre Addition

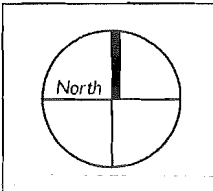
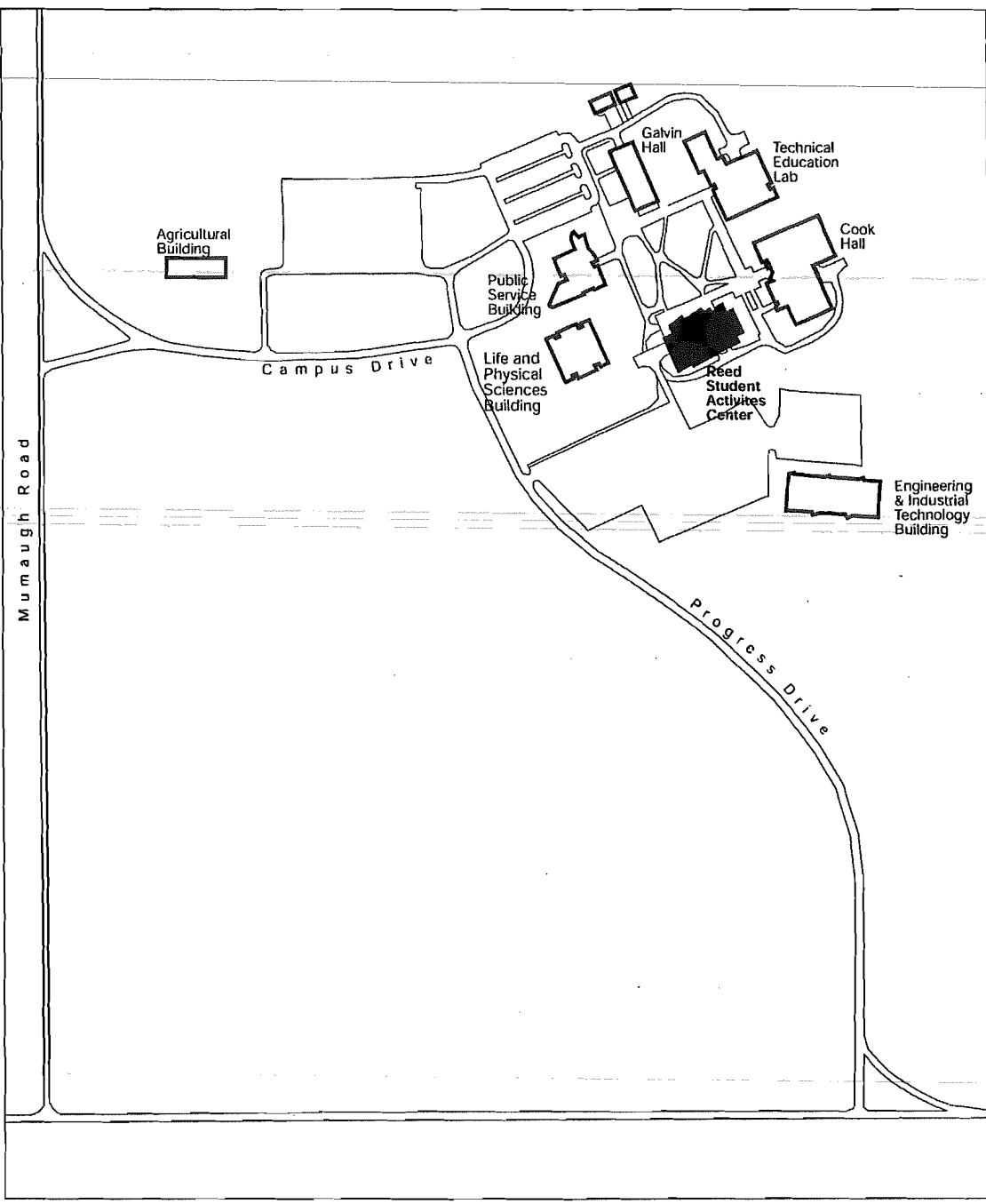

Office of Business and Finance
Office of Facilities Planning and Development

December 9, 2000



Starling-Loving Hall - Biostatistics

315-2001-928

Requesting Agency(s): RESEARCH, OFFICE OF

Location(s): STARLING LOVING HALL

Gross Sq. Ft.141,920 Age: 1917

Description: This project renovates approximately 1,500 square feet of space in Starling-Loving Hall to be used as new additional office space for Biostatistics. The renovation includes additional wall partitions, new ceilings, repair of existing walls and ceilings, weather seal existing windows, update electrical and data outlets, and upgrade finishes conducive of office areas.

Project Team:

Facility Planner: Is Unassigned

Project Captain: Christine Lawson
(lawson.132@osu.edu)

Project Assistant: Andrea Thimmes
(thimmes.5@osu.edu)

Field Coordinator: Is Unassigned

Project Information:

Formerly known as project 50700-R015107

Original project budget of \$315,000 approved by the Board of Trustees on December 6, 2001. Project budget increased to \$660,911 to reflect a change in scope; office mezzanine level and window replacement.

Source of Funds:	Original	Revised	Uses of Funds:	As Designed	As Bid	Completion
General Funds-Research	\$315,000.00	\$558,062.00				
Auxiliary - College of Medicine	\$0.00	\$102,849.00	Total:			
Total:	\$315,000.00	\$660,911.00				

Schedule:	Projected	Revised	Actual
Planning			
Arch/Engr Approved by B/T (\$315,000 Project)	12/06/2001		12/06/2001
Bidding Approved B/T (\$315,000 Project)	12/06/2001	09/13/2002	12/06/2001
Bidding Approved B/T (\$660,911 Project)	02/07/2003		
Bidding			
Bid Opening	02/06/2003		

Starling - Loving Hall - Biostatistics

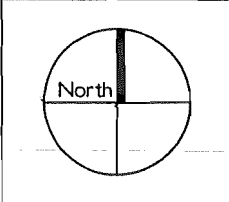
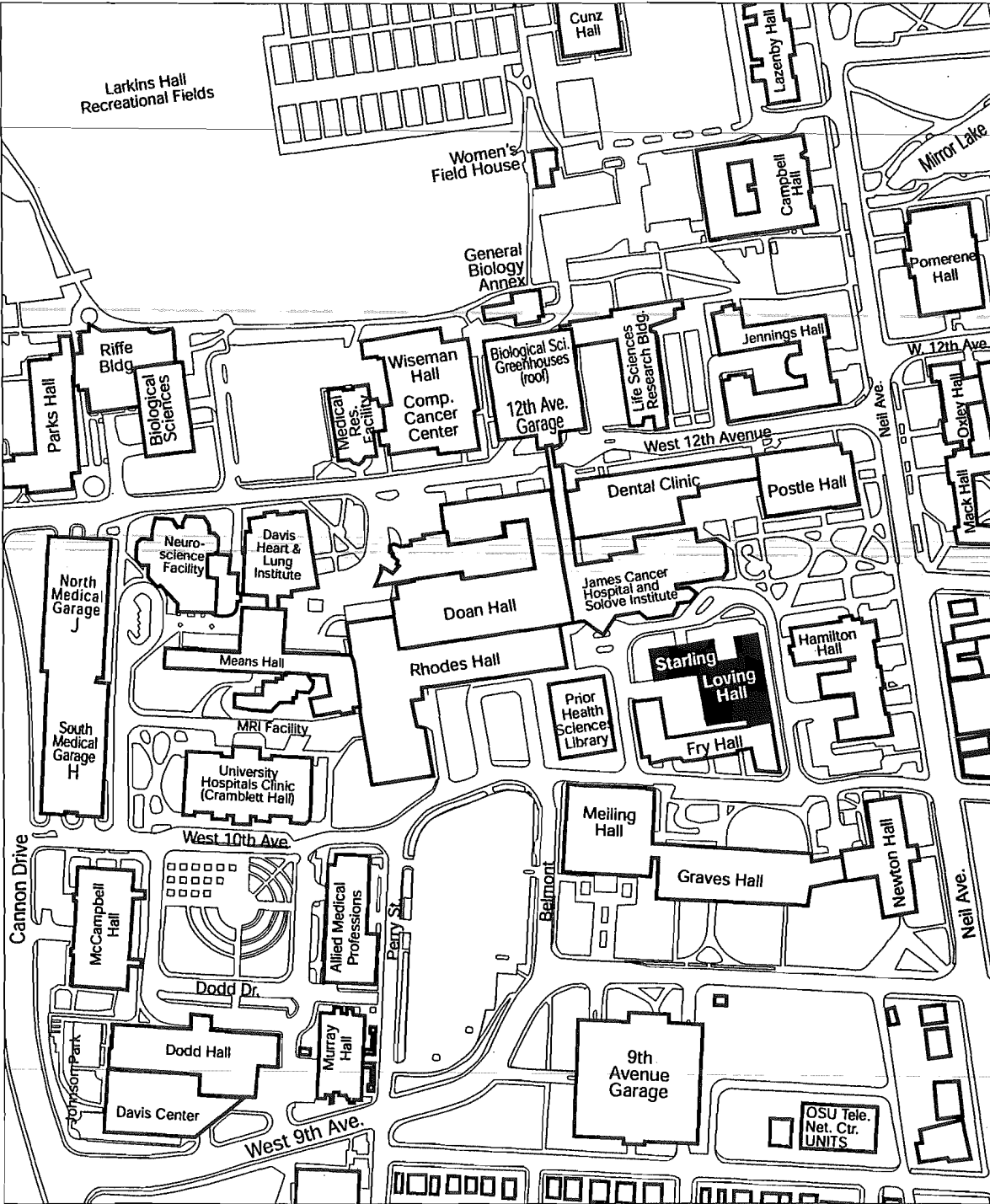

Office of Business and Finance
Office of Facilities Planning and Development

November 14, 2001



Requesting Agency(s): ACADEMIC AFFAIRS, OFFICE OF

Location(s): Site - See Comments.

Gross Sq. Ft.0 Age:

Description: Employ an architect/engineer firm to assist with the completion of measured drawings, provide space use recommendations, and provide design services for the renovation of space in the ABB facility on at 650 Ackerman Road.

Project Team:

Facility Planner: Is Unassigned
Project Captain: Is Unassigned
Project Assistant: Is Unassigned
Field Coordinator: Is Unassigned

Project Information:

Cost to be determined depending on type of renovation required by future tenants. Cost of renovation will be paid by building occupants.

Source of Funds:	Original	Revised	Uses of Funds:	As Designed	As Bid	Completion
			Total:			

Schedule:

	Projected	Revised	Actual
Planning			
Arch/Engr Approved by B/T (Cost undetermined)	02/07/2003		

650 ACKERMAN ROAD RENOVATIONS
THE OHIO STATE UNIVERSITY
COLUMBUS, OHIO

OFFICE OF FACILITIES PLANNING AND DEVELOPMENT

DATE: FEB. 5, 2003
SCALE: NO TRUE SCALE
DRAWN BY: O.J.T.
REVISIONS:

SHEET

1 / 1

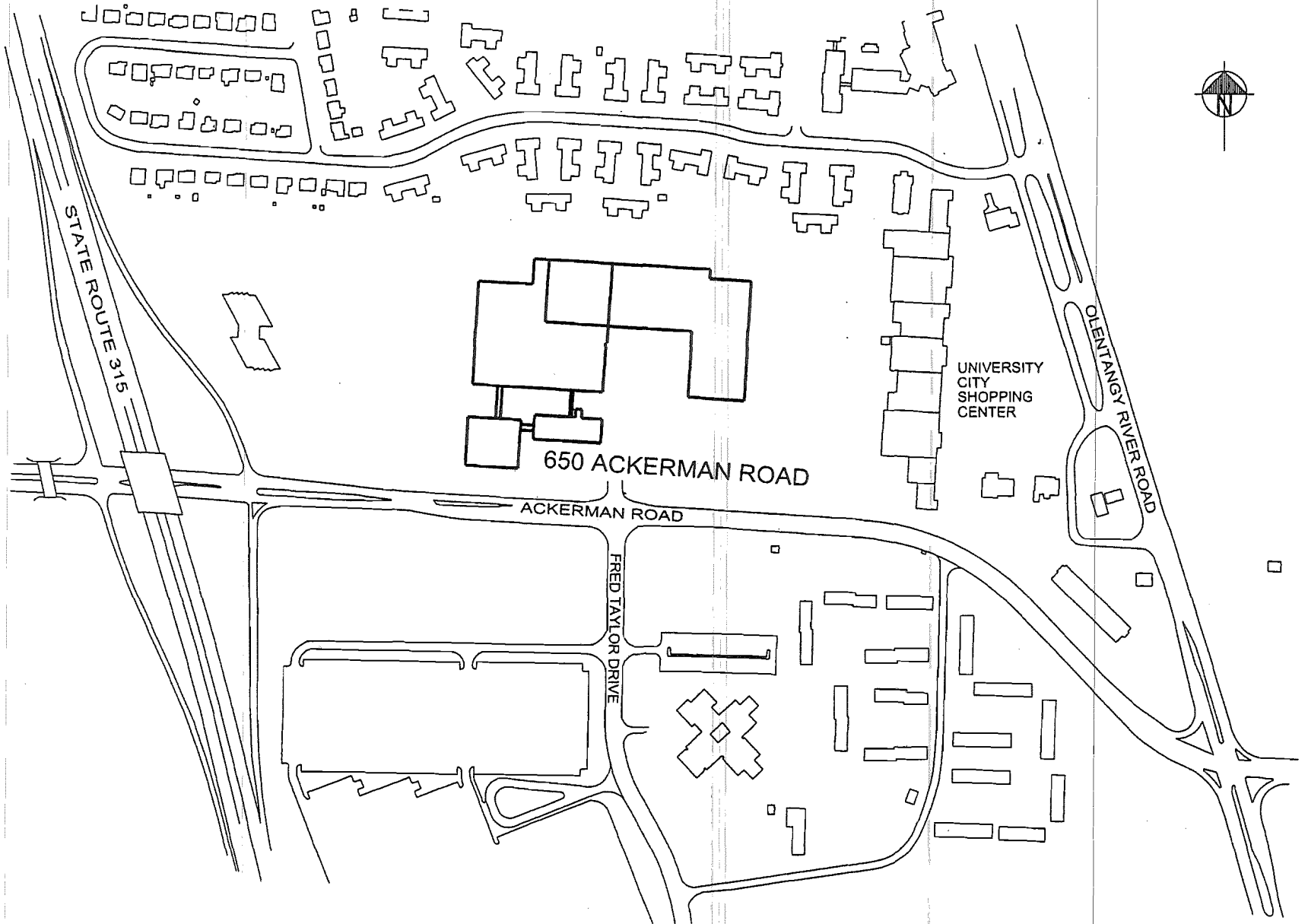



Requesting Agency(s): ATHLETICS

Location(s): WOODY HAYES ATHLETIC CENTER

Gross Sq. Ft. 170,270 Age: 1987

Description: Replacement of the artificial turf on the indoor football field in the Woody Hayes Athletic Center (WHAC).

Project Team:

Facility Planner: Is Unassigned

Project Captain: Thomas Heretta
(heretta.1@osu.edu)

Project Assistant: Curt Handschug
(handschug.1@osu.edu)

Field Coordinator: Is Unassigned

Project Information:

Formerly known as 50700-R021688
Preliminary project budget of \$480,000

Source of Funds:	Original	Revised	Uses of Funds:	As Designed	As Bid	Completion
			Total:			

Schedule:	Projected	Revised	Actual
Planning			
Arch/Engr Approved by B/T (\$480,000 Project)	02/07/2003		



Football Practice Field #4 - Turf Installation

315-2003-903

Requesting Agency(s): ATHLETICS

Location(s): Site - See Comments.

Gross Sq. Ft.0 Age:

Description: Replace turf surface on football field four with an infill artificial surface. Complete with pad layer, diagonal, and field markings.

OFP #03-18

Project Team:

Facility Planner: Is Unassigned

Project Captain: Thomas Heretta
(heretta.1@osu.edu)

Project Assistant: Curt Handschug
(handschug.1@osu.edu)

Field Coordinator: Is Unassigned

Project Information:

Formerly known as project 50700-R031714
Preliminary project budget of \$540,000

Source of Funds:	Original	Revised	Uses of Funds:	As Designed	As Bid	Completion
Total:						

Schedule:	Projected	Revised	Actual
Planning Arch/Engr Approved by B/T (\$540,000 Project)	02/07/2003		

Athletic Field Replacement

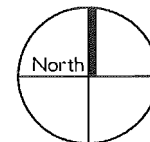
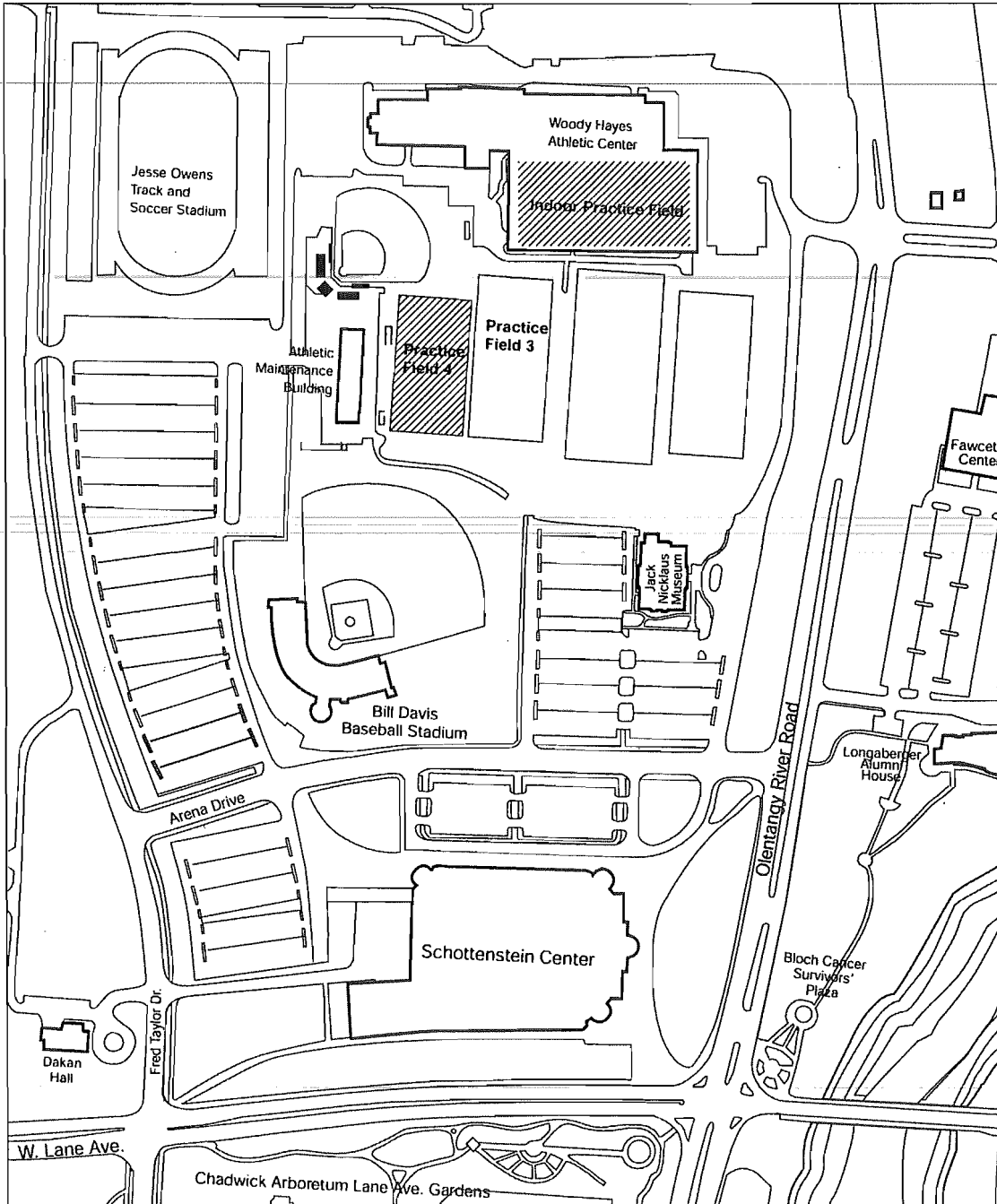

Office of Business and Finance
Office of Facilities Planning and Development

January 29, 2003



ATI - Shisler Center Courtyard
315-2002-903

Requesting Agency(s): ATI-ADMINISTRATIVE SUPPORT

Location(s): Various Locations-ATI

Gross Sq. Ft.0 Age:

Description: Complete the exterior courtyard including landscaping. This is the final phase of the Shisler/CEED Project.

Project Team:

Facility Planner: Is Unassigned

Project Captain: Marjory Spangler
(spangler.40@osu.edu)

Project Assistant: Leeanne Chandler
(chandler.63@osu.edu)

Field Coordinator: Marjory Spangler
(spangler.40@osu.edu)

Project Information:

Source of Funds:	Original	Revised	Uses of Funds:	As Designed	As Bid	Completion
HB640 ATI Basic	\$300,000.00	\$300,000.00	Construction	\$286,650.00	\$256,050.00	\$0.00
Renovations			Contingency	\$15,279.25	\$15,279.25	\$0.00
Total:	\$300,000.00	\$300,000.00	Design	\$24,830.00	\$24,830.00	\$0.00
			University Administration	\$4,299.75	\$3,840.75	\$0.00
			Total:	\$331,059.00	\$300,000.00	\$0.00

Schedule:

	Projected	Revised	Actual
Planning			
Arch/Engr Approved by B/T (\$300,000 Project)	03/01/2002		03/01/2002
Bidding Approved B/T (\$300,000 Project)	03/02/2002		03/01/2002
Design			
Arch/Engr Contract	04/12/2002		04/12/2002
Construction Document Approval	05/17/2002		05/17/2002
Bidding			
Bid Opening	06/15/2002	08/08/2002	08/08/2002
Construction			
Construction Start	08/05/2002	10/08/2002	10/01/2002
Report of Award to B/T (\$300,000 Project)	12/06/2002	02/07/2003	
Completion	10/31/2002	12/15/2002	12/15/2002

ATI - Shisler Center Courtyard

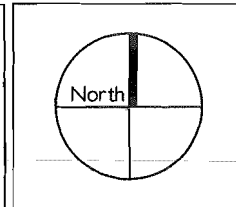
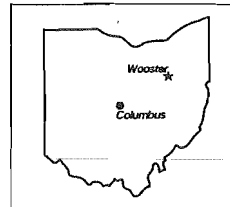
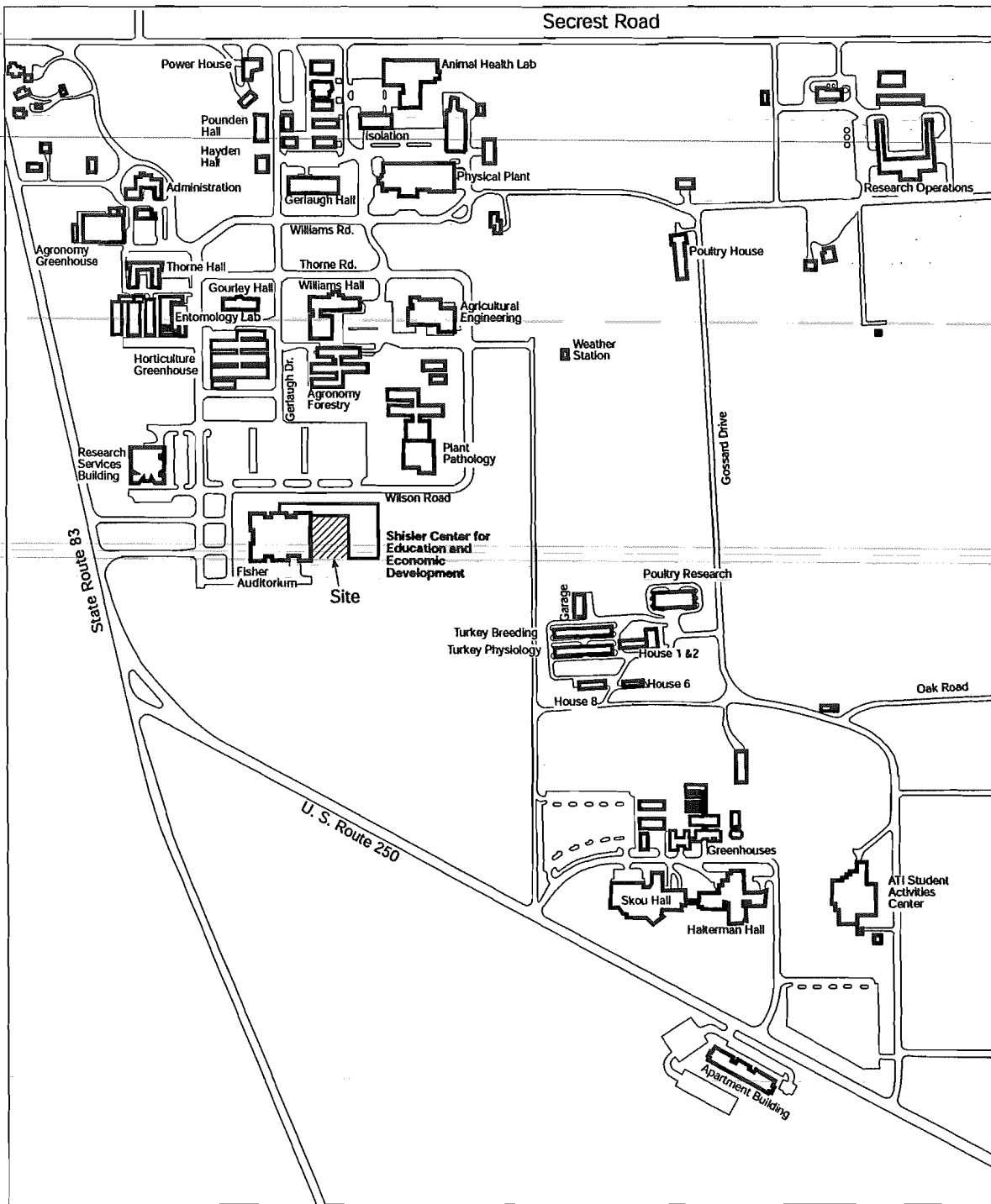

Office of Business and Finance
Office of Facilities Planning and Development

February 7, 2002



Bevis Hall Roof Replacement

315-2000-941

Requesting Agency(s): PHYSICAL FACILITIES

Location(s): BEVIS HALL, HOWARD L.

Gross Sq. Ft.80,178 Age: 1969

Description: The existing EPDM roof membrane and lightweight insulation will be removed, new tapered ISO insulation and a modified bitumen roof membrane will be installed. Also required is the rehabilitation of concrete curbs and installation of new caps and OSHA fall protection.

Project Team:

Facility Planner: Is Unassigned

Project Captain: Scotty Pike
(pike.1@osu.edu)

Project Assistant: Andrea Thimmes
(thimmes.5@osu.edu)

Field Coordinator: Scotty Pike
(pike.1@osu.edu)

Project Information:

Being designed by outside consulting firm.

Source of Funds:	Original	Revised	Uses of Funds:	As Designed	As Bid	Completion
HB640 Basic Renovations	\$350,000.00	\$327,350.50	Construction	\$290,500.00	\$266,700.00	\$0.00
Total:	\$350,000.00	\$327,350.50	Contingency	\$25,162.50	\$26,670.00	\$0.00
			Design	\$29,980.00	\$29,980.00	\$0.00
			University Administration	\$4,357.50	\$4,000.50	\$0.00
			Total:	\$350,000.00	\$327,350.50	\$0.00

Schedule:

	Projected	Revised	Actual
Planning			
Arch/Engr Approved by B/T (\$350,000 Project)	02/02/2001		02/02/2001
Bidding Approved B/T (\$350,000 Project)	02/02/2001		02/02/2001
Design			
Arch/Engr Contract	08/01/2001		07/20/2001
Schematic Design Approval	11/01/2001		09/18/2001
Design Dev Document Approval	11/01/2001		09/18/2001
Construction Document Approval	02/01/2002		02/01/2002
Bidding			
Bid Opening	04/01/2002	05/30/2002	05/30/2002
Construction			
Award of Contracts	06/01/2002	08/23/2002	08/16/2002
Construction Start	06/15/2002	08/26/2002	08/29/2002
Report of Award to B/T (\$327,350.50 Project)	12/01/2002	03/07/2003	
Completion	09/15/2002	02/28/2003	

Bevis Hall - Roof Replacement

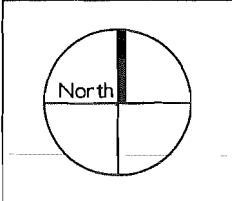
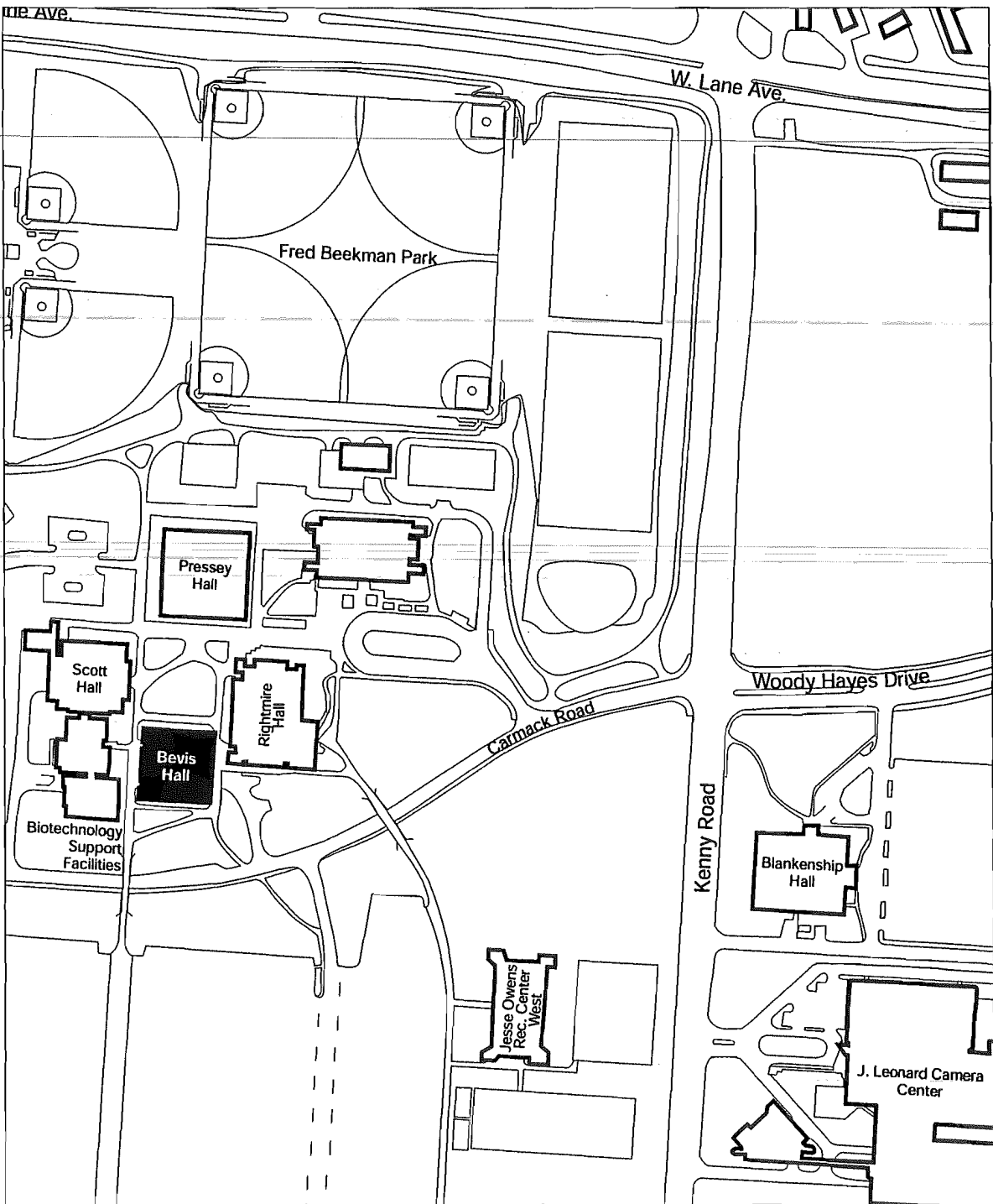

Office of Business and Finance
Office of Facilities Planning and Development

January 13, 2003



Bolz Hall - Roof Replacement
315-1996-921

Requesting Agency(s): PHYSICAL FACILITIES

Location(s): BOLZ HALL, HAROLD A

Gross Sq. Ft. 81,488 Age: 1960

Description: Remove approximately 31,600 sq. ft. of built-up roof and install a new tapered insulation and 4-ply asphalt roof. Install new metal flashing.

Project Team:

Facility Planner: Is Unassigned

Project Captain: Scotty Pike
(pike.1@osu.edu)

Project Assistant: Leeanne Chandler
(chandler.63@osu.edu)

Field Coordinator: Scotty Pike
(pike.1@osu.edu)

Project Information:

Local administration approved by the Board of Regents on 8/5/96.

Source of Funds:	Original	Revised	Uses of Funds:	As Designed	As Bid	Completion
HB748 Columbus Basic	\$280,000.00	\$231,409.00	Construction	\$238,000.00	\$192,600.00	\$0.00
Renovation			Contingency	\$23,800.00	\$19,260.00	\$0.00
			Design	\$16,660.00	\$16,660.00	\$0.00
Total:	\$280,000.00	\$231,409.00	University Administration	\$3,570.00	\$2,889.00	\$0.00
			Total:	\$282,030.00	\$231,409.00	\$0.00

Schedule:	Projected	Revised	Actual
Planning			
Arch/Engr Approved by B/T (\$280,000 Project)	12/08/1996		12/06/1996
Bidding Approved B/T (\$280,000 Project)	12/08/1996		12/06/1996
Design			
Schematic Design Approval	02/28/1997	04/01/2000	03/01/2000
Design Dev Document Approval	02/28/1997	04/01/2000	03/01/2000
Construction Document Approval	06/15/1997	10/10/2000	10/04/2000
Bidding			
Bid Opening	08/15/1997	08/13/2002	08/13/2002
Construction			
Award of Contracts	10/15/1997	10/15/2002	09/30/2002
Construction Start	05/01/1998	06/01/2003	
Report of Award to B/T (\$231,409 Project)	11/15/1997	02/07/2003	
Completion	09/01/1998	09/01/2003	

Bolz Hall - Roof Replacement

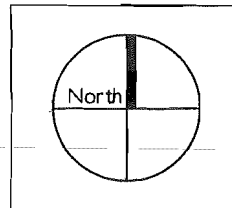
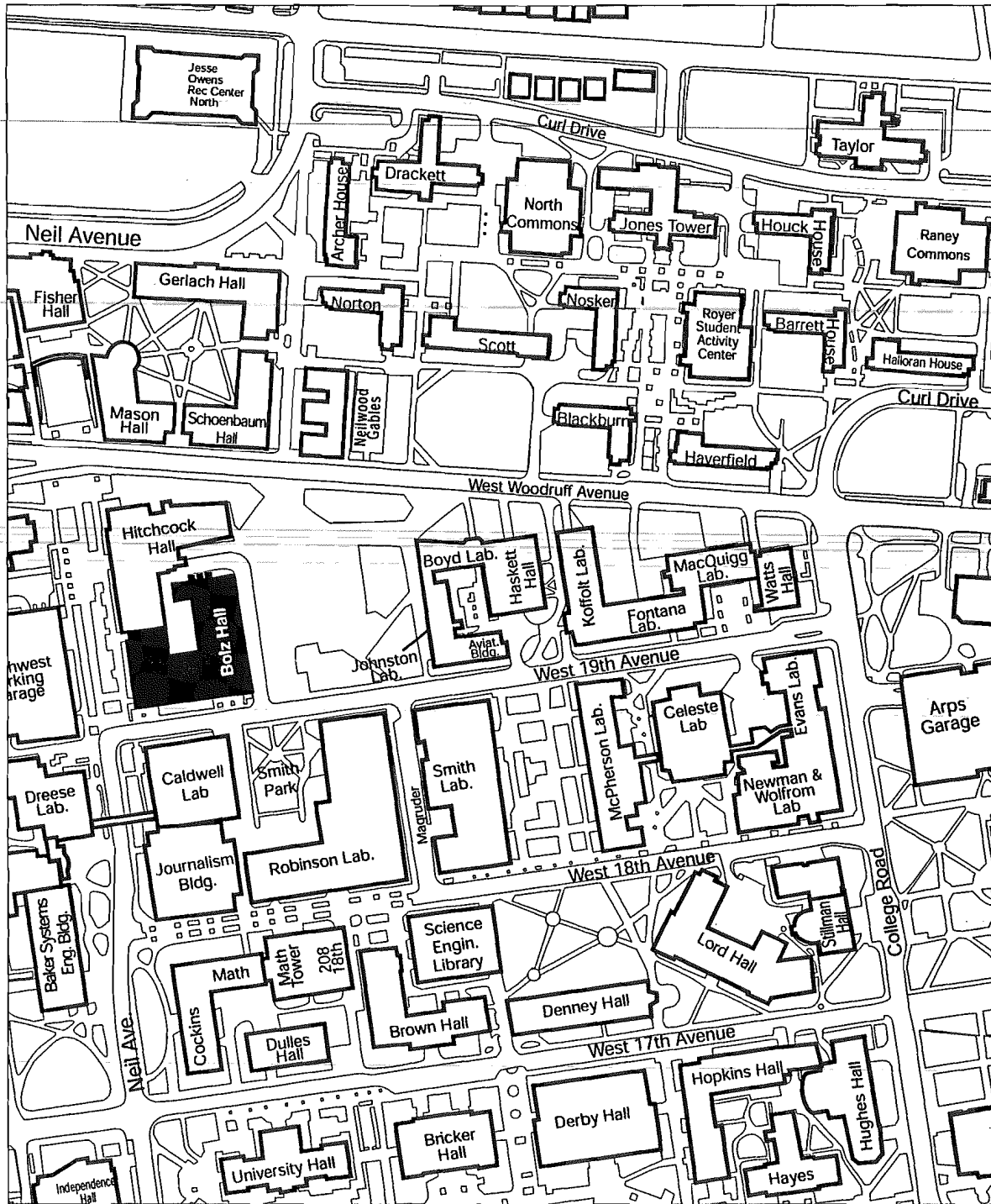

Office of Business and Finance
Office of Facilities Planning and Development

January 13, 2003



Byrd Polar Research Center - Rock Repository

315-2000-901

Requesting Agency(s): RESEARCH, OFFICE OF

Location(s): SCOTT HALL, WILLIAM H

Gross Sq. Ft.58,109 Age: 1972

Description: Construct a 5,700 square foot single story building that will house the Byrd Polar Center's Antarctic rock collection and extend the existing loading dock to connect the building with the existing cold storage building and Scott Hall.

Project Team:

Facility Planner: Cheryl Christie
(christie.2@osu.edu)
Project Captain: Stephen Angelo
(angelo.6@osu.edu)
Project Assistant: Mikki Reese
(reese.153@osu.edu)
Field Coordinator: Is Unassigned

Project Information:

Project was reviewed by the Design Review Board at which time suggestions were made on the appearance. These suggestions later made the original bid complex and along with an uncooperative user, base bid estimates were miscalculated. The project was re-designed with the Department adding more money, and the base bid estimates in line with the bidding climate.

Source of Funds:	Original	Revised	Uses of Funds:	As Designed	As Bid	Completion
General Funds-Math & Physical Sci	\$5,000.00	\$5,000.00	Construction	\$606,350.00	\$552,379.00	\$0.00
General Funds-Research	\$89,293.00	\$75,597.00	Contingency	\$33,240.31	\$33,240.31	\$0.00
Other	\$0.00	\$50,000.00	Design	\$57,000.00	\$57,000.00	\$0.00
Restricted-Research			Equipment	\$77,925.00	\$77,925.00	\$0.00
BOR Action Fund	\$94,292.00	\$94,292.00	University Administration	\$9,095.25	\$8,285.69	\$0.00
Grant-National Science Foundation	\$503,941.00	\$503,941.00	Total:	\$783,610.56	\$728,830.00	\$0.00
Total:	\$692,526.00	\$728,830.00				

Schedule:	Projected	Revised	Actual
Planning			
Arch/Engr Approved by B/T (\$692,526 Project)	07/07/2000		07/07/2000
Bidding Approved B/T (\$692,526 Project)	07/07/2000		07/07/2000
Design			
Schematic Design Approval	12/31/2000	01/07/2002	01/07/2002
Design Dev Document Approval	03/01/2001	01/07/2002	01/07/2002
Construction Document Approval	05/01/2001	04/01/2002	07/01/2002
Bidding			
Bid Opening (Re-Bid)	09/26/2002		09/26/2002
Bid Opening	06/15/2001	08/14/2002	08/14/2002
Construction			
Award of Contracts	08/01/2001	12/27/2002	12/19/2002
Construction Start	08/15/2001	12/30/2002	12/23/2002
Report of Award to B/T (\$728,830 Project)	12/01/2001	02/07/2003	
Completion	02/15/2002	06/21/2003	

Byrd Polar Research Center - Rock Repository

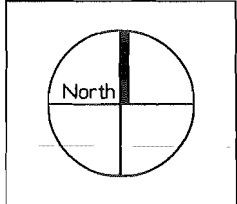
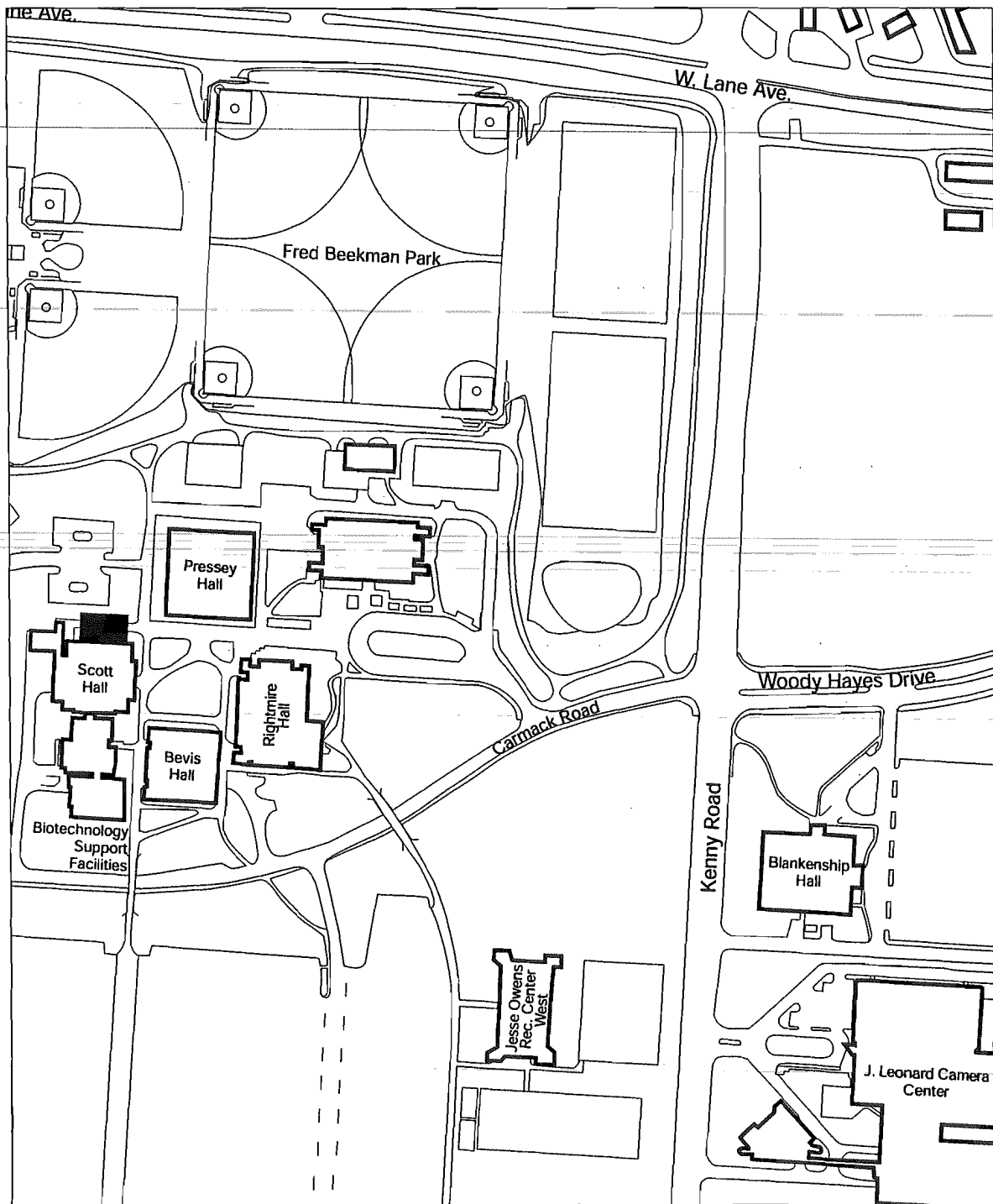

Office of Business and Finance
Office of Facilities Planning and Development

January 13, 2003



Campus Grounds - Neil Avenue Street Rebuild

315-2000-938

Requesting Agency(s): PHYSICAL FACILITIES

Location(s): Unidentified Street-Col.

Gross Sq. Ft.0 Age:

Description: Upgrade the base and repair damage caused by heavy vehicles. The section of road between the control gates will be rebuilt to carry bus traffic.

Project Team:

Facility Planner: Is Unassigned
 Project Captain: Gary Collier
 (collier.26@osu.edu)
 Project Assistant: Curt Handschug
 (handschug.1@osu.edu)
 Field Coordinator: Glenn Gerhart
 (gerhart.1@osu.edu)

Project Information:

\$70,231. of additional funds added to the project to complete additional work requested by the user during construction.

Source of Funds:	Original	Revised	Uses of Funds:	As Designed	As Bid	Completion
HB640 Line Item	\$0.00	\$0.00	Construction	\$479,910.00	\$420,375.00	\$0.00
Appropriation			Contingency	\$31,819.00	\$31,819.00	\$0.00
HB640 Basic Renovations	\$500,000.00	\$566,030.00	Design	\$41,500.00	\$41,500.00	\$0.00
Repair & Renovation	\$0.00	\$4,201.85	University Administration	\$7,199.00	\$6,306.00	\$0.00
Fiscal Yr 01-02			Total:	\$560,428.00	\$500,000.00	\$0.00
Total:	\$500,000.00	\$570,231.85				

Schedule:

	Projected	Revised	Actual
Planning			
Arch/Engr Approved by B/T (\$500,000 Project)	02/02/2001		02/02/2001
Bidding Approved B/T (\$500,000 Project)	02/02/2001		02/02/2001
Design			
Arch/Engr Contract	06/01/2001		08/14/2001
Schematic Design Approval	09/15/2001	10/15/2001	10/08/2001
Design Dev Document Approval	09/15/2001	12/01/2001	12/10/2001
Construction Document Approval	01/01/2002	02/08/2002	02/15/2002
Bidding			
Bid Opening	03/01/2002	04/30/2002	04/30/2002
Construction			
Award of Contracts	05/01/2002	06/03/2002	06/14/2002
Construction Start	06/15/2002	06/17/2002	06/19/2002
Report of Award to B/T (\$500,000 Project)	12/01/2002	02/07/2003	
Completion	09/01/2002	11/09/2002	11/09/2002

Campus Grounds - Neil Avenue Street Rebuild

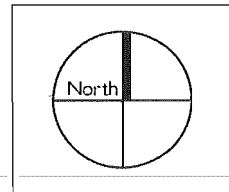
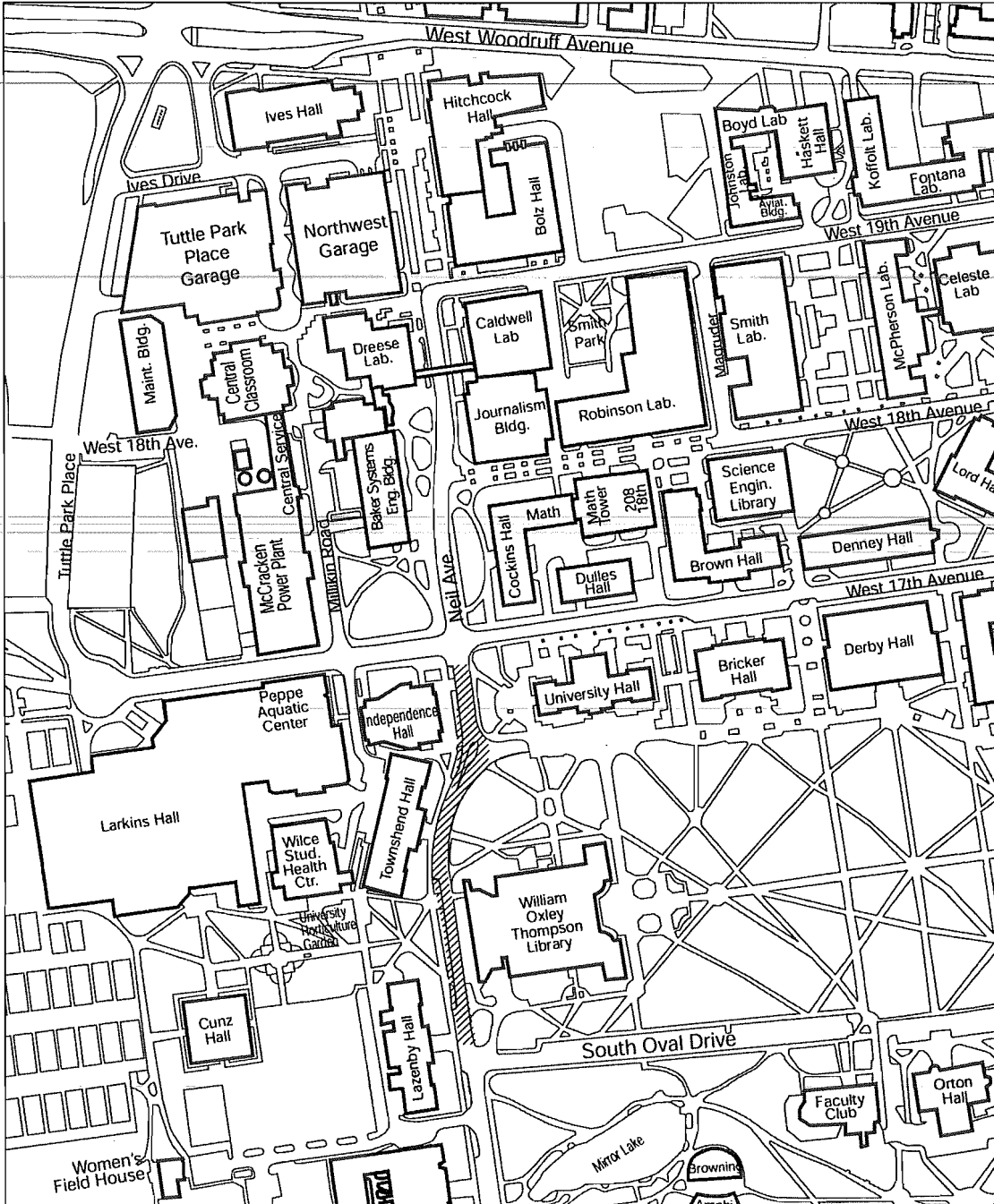

Office of Business and Finance
Office of Facilities Planning and Development

January 14, 2003



Celeste Laboratory HVAC Modifications

315-2000-925

Requesting Agency(s): PHYSICAL FACILITIES

Location(s): CELESTE LABORATORY OF CHEMISTRY

Gross Sq. Ft. 110,269 Age: 1986

Description: This project will modify pumps, piping and controls to the chilled water systems so that McPherson, Evans, Newman-Wolfram and Celeste chillers operate as a single system. This will improve air conditioning reliability and reduce operating and maintenance costs.

Project Team:

Facility Planner: Is Unassigned

Project Captain: Colin McBride
(mcbride.62@osu.edu)

Project Assistant: Curt Handschug
(handschug.1@osu.edu)

Field Coordinator: Is Unassigned

Project Information:

Project budget reduced due to bids that were below estimates.

Source of Funds:	Original	Revised	Uses of Funds:	As Designed	As Bid	Completion
HB640 Basic Renovations	\$800,000.00	\$419,104.89	Construction	\$552,000.00	\$316,686.00	\$0.00
Total:	\$800,000.00	\$419,104.89	Contingency	\$55,200.00	\$31,669.00	\$0.00
			Design	\$66,000.00	\$66,000.00	\$0.00
			University Administration	\$8,280.00	\$4,750.00	\$0.00
			Total:	\$681,480.00	\$419,105.00	\$0.00

Schedule:	Projected	Revised	Actual
Planning			
Arch/Engr Approved by B/T (\$800,000 Project)	08/30/2000		08/30/2000
Bidding Approved B/T (\$800,000 Project)	08/30/2000		08/30/2000
Design			
Arch/Engr Contract	12/01/2000	04/30/2001	04/13/2001
Schematic Design Approval	03/01/2001	09/30/2001	10/02/2001
Design Dev Document Approval	03/01/2001	09/30/2001	10/02/2001
Construction Document Approval	06/01/2001	02/28/2002	05/24/2002
Bidding			
Bid Opening	08/01/2001	06/30/2002	08/29/2002
Construction			
Award of Contracts	09/01/2001	12/20/2002	12/09/2002
Construction Start	10/01/2001	12/31/2002	01/06/2003
Report of Award to B/T (\$419,105 Project)	12/01/2001	02/07/2003	
Completion	03/01/2002	05/30/2003	

Celeste Laboratory - HVAC Modifications

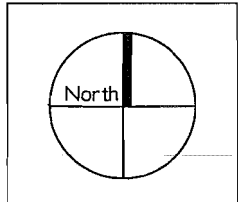
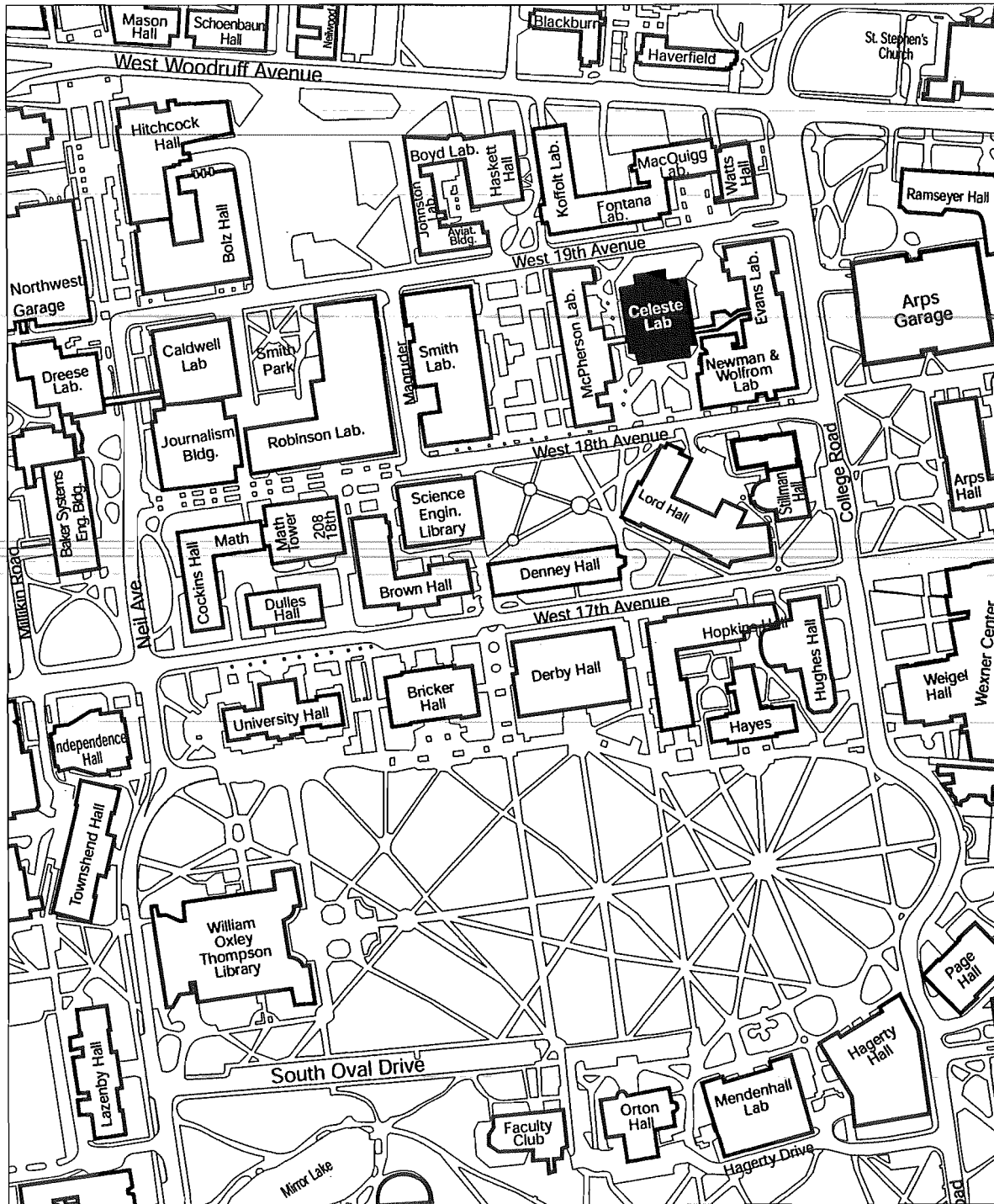

Office of Business and Finance
Office of Facilities Planning and Development

January 13, 2003



Central Chilled Water Loop 17th Ave to Derby Hall

5062-PF990624

Requesting Agency(s): BUSINESS & FINANCE, OFFICE OF

Location(s): DERBY HALL, SAMUEL C.

Gross Sq. Ft. 115,263 Age: 1906

Description: This project extends the Central Chilled Water System to the Dulles Hall chiller plant, which feeds Dulles, University, Bricker & Derby Halls. Two 27 y/o chillers in Dulles Hall will be replaced with variable volume pumps and a heat exchanger that will cool these buildings via the McCracken Central Chilled Water System.

Project Team:

Facility Planner: Is Unassigned

Project Captain: Jerry Bender
(bender.3@osu.edu)

Project Assistant: Lisa Baldwin
(baldwin.10@osu.edu)

Field Coordinator: Mark Hartmann
(hartmann.16@osu.edu)

Project Information:

In addition, 14" supply & return piping and valving will be installed underground along Neil Ave to cross-connect the McCracken North distribution loop to the South distribution loop to provide emergency backup chilled water in either direction should an outage be required in either the North or South feeds out of the McCracken Plant.

Source of Funds:	Original	Revised	Uses of Funds:	As Designed	As Bid	Completion
Future Univ. Bond Issues	\$800,000.00	\$800,000.00	Construction	\$809,000.00	\$647,406.00	\$412,147.20
Total:	\$800,000.00	\$800,000.00	Contingency	\$23,525.00	\$96,197.00	\$43,118.00
			Equipment	\$54,297.00	\$54,297.00	\$54,297.00
			University Administration	\$2,100.00	\$2,100.00	\$2,100.00
			Total:	\$888,922.00	\$800,000.00	\$511,662.20

Schedule:	Projected	Revised	Actual
Planning			
Arch/Engr Approved by B/T (\$800,000 Project)	02/02/2001		02/02/2001
Bidding Approved B/T (\$800,000 Project)	02/02/2001		02/02/2001
Design			
Construction Document Approval	03/05/2001		02/15/2001
Bidding			
Bid Opening	07/02/2001	03/02/2001	03/02/2001
Construction			
Award of Contracts	09/30/2001		03/28/2001
Construction Start	10/01/2001		04/02/2001
Report of Award to B/T (\$800,000 Project)	12/01/2001	02/07/2003	
Completion	04/01/2002	08/12/2002	08/12/2002

Central Chilled Water Loop 17th Avenue to Derby Hall

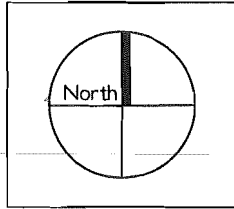
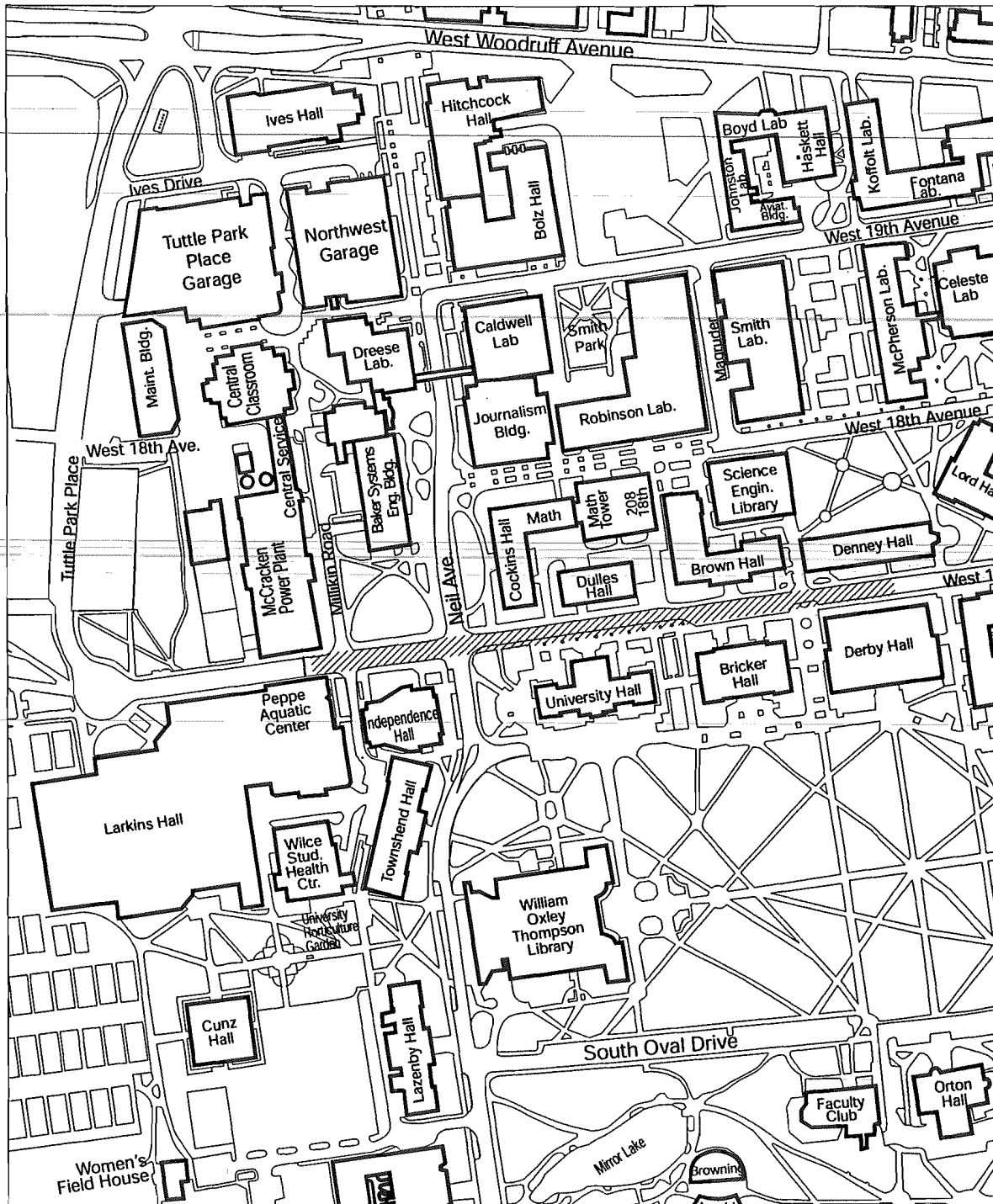

Office of Business and Finance
Office of Facilities Planning and Development

January 14, 2003



Cockins Hall - Math/Statistics Learning Lab.

315-1999-903

Requesting Agency(s): MATHEMATICAL & PHYSICAL SCIENCES ADMIN

Location(s): COCKINS HALL, EDITH

Gross Sq. Ft.60,863 Age: 1930

Description: Renovate selected areas in the basement and first floors of Cockins Hall and one suite in the Math Building for the Mathematics and Statistics Learning Lab to provide open study areas, reservable rooms for peer led study groups, computers with statistical and tutorial software, support of WEB pages and multimedia course materials and facilities for enhancing the classroom skills of tutors, TA's and lecturers.

Project Team:

Facility Planner: John Lanning
(lanning.29@osu.edu)
Project Captain: Ruth Miller
(miller.2495@osu.edu)
Project Assistant: Leeanne Chandler
(chandler.63@osu.edu)
Field Coordinator: Is Unassigned

Project Information:

Project budget reduced due to good bids received. Additional \$114,200 requested to be returned to the project during the construction phase as additional asbestos abatement and unforeseen construction conditions were encountered.

Source of Funds:	Original	Revised	Uses of Funds:	As Designed	As Bid	Completion
Centrally Funded Capital	\$0.00	\$48,100.00	Construction	\$689,859.00	\$514,628.00	\$0.00
Projects			Contingency	\$51,436.00	\$51,463.00	\$0.00
HB850 Columbus Basic	\$800,000.00	\$647,065.00	Design	\$92,355.00	\$92,355.00	\$0.00
Renovation			Moving	\$9,000.00	\$9,000.00	\$0.00
HB640 Basic Renovations	\$0.00	\$94,200.00	University Administration	\$7,719.00	\$7,719.00	\$0.00
Total:	\$800,000.00	\$789,365.00	Total:	\$850,369.00	\$675,165.00	\$0.00

Schedule:	Projected	Revised	Actual
Planning			
Arch/Engr Approved by B/T (\$800,000 Project)	02/05/1999		02/05/1999
Bidding Approved B/T (\$800,000 Project)	02/05/1999		02/05/1999
Design			
Arch/Engr Contract	09/25/2000		09/14/2000
Schematic Design Approval	11/15/2000	12/05/2000	12/05/2000
Design Dev Document Approval	01/15/2001		01/15/2001
Construction Document Approval	03/15/2001	08/30/2001	09/12/2001
Bidding			
Bid Opening	05/30/2001	03/01/2002	01/16/2002
Construction			
Award of Contracts	07/25/2001	05/31/2002	05/28/2002
Construction Start	07/26/2001	05/24/2002	05/28/2002
Report of Award to B/T (\$675,165 Project)	12/01/2001	02/07/2003	
Completion	03/26/2001	11/04/2002	11/04/2002

Cockins Hall - Math/Statistics Learning Lab

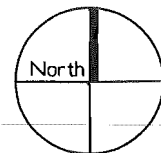
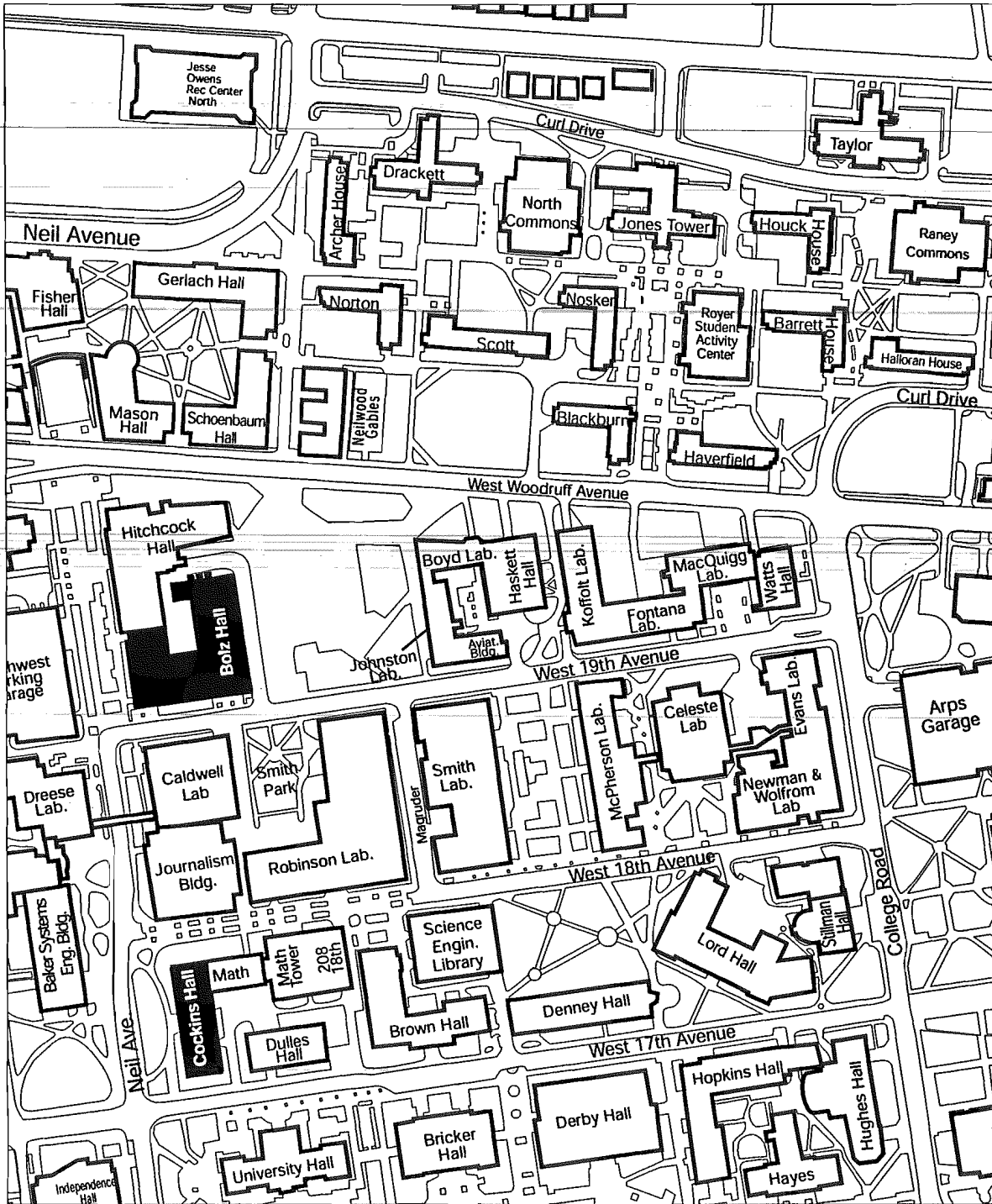

Office of Business and Finance
Office of Facilities Planning and Development

January 13, 2003



Dodd Hall - Chilled Water Plant Structure

315-2001-908

Requesting Agency(s): HEALTH SCIENCES ADMINISTRATION

Location(s): DODD HALL, VERNE A.

Gross Sq. Ft. 84,673 Age: 1961

Description: Replacement of the chiller plant for Dodd Hall and associated construction/renovation to accommodate including but not limited to screening walls.

Project Team:

Facility Planner: Is Unassigned

Project Captain: Pat Cuthbert
(cuthbert.8@osu.edu)

Project Assistant: Andrea Thimmes
(thimmes.5@osu.edu)

Field Coordinator: Pat Cuthbert
(cuthbert.8@osu.edu)

Project Information:

The estimated cost of construction was increased, therefore increasing the overall project budget to \$1,098,904.00. This was due to an increase in the erection price of the steel, a substantial increase in sprinkler work, a higher cost for roof repairs due to two separate warranties for Dodd and Davis Hall, increased rigging costs, and higher temperature controls pricing than what was provided at the time of design. A bid justification was issued from the Associate Architect on August 19, 2002 and from the Engineer on August 14, 2002 outlining the reasons for the increase in the budget.

Source of Funds:	Original	Revised	Uses of Funds:	As Designed	As Bid	Completion
Auxiliaries-University	\$864,500.00	\$1,098,904.00	Construction	\$958,470.00	\$880,900.00	\$0.00
Hospitals			Contingency	\$88,090.00	\$88,090.00	\$0.00
Total:	\$864,500.00	\$1,098,904.00	Design	\$91,880.00	\$91,880.00	\$0.00
			University Administration	\$13,213.00	\$13,213.50	\$0.00
			Total:	\$1,151,653.00	\$1,074,083.50	\$0.00

Schedule:

	Projected	Revised	Actual
Planning			
Arch/Engr Approved by B/T (\$864,500 Project)	08/29/2001		08/29/2001
Bidding Approved B/T (\$864,500 Project)	08/29/2001		08/29/2001
Design			
Arch/Engr Contract	01/15/2002	02/15/2002	02/04/2002
Schematic Design Approval	04/20/2002	02/12/2002	02/26/2002
Design Dev Document Approval	08/20/2002	04/01/2002	05/02/2002
Construction Document Approval	10/20/2002	06/21/2002	06/11/2002
Bidding			
Bid Opening (Re-Bid of G, P, and M)	09/10/2002		09/10/2002
Bid Opening	12/15/2002	08/01/2002	07/31/2002
Construction			
Award of Contracts	02/15/2003	11/09/2002	11/06/2002
Construction Start	02/20/2003	11/11/2002	11/11/2002
Report of Award to B/T (\$1,074,083.50 Project)	12/01/2003	02/07/2003	
Completion	08/20/2003	05/10/2003	

Dodd Hall Chilled Water Plant Structure

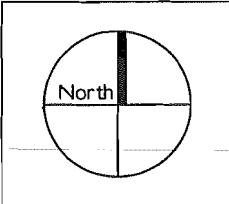
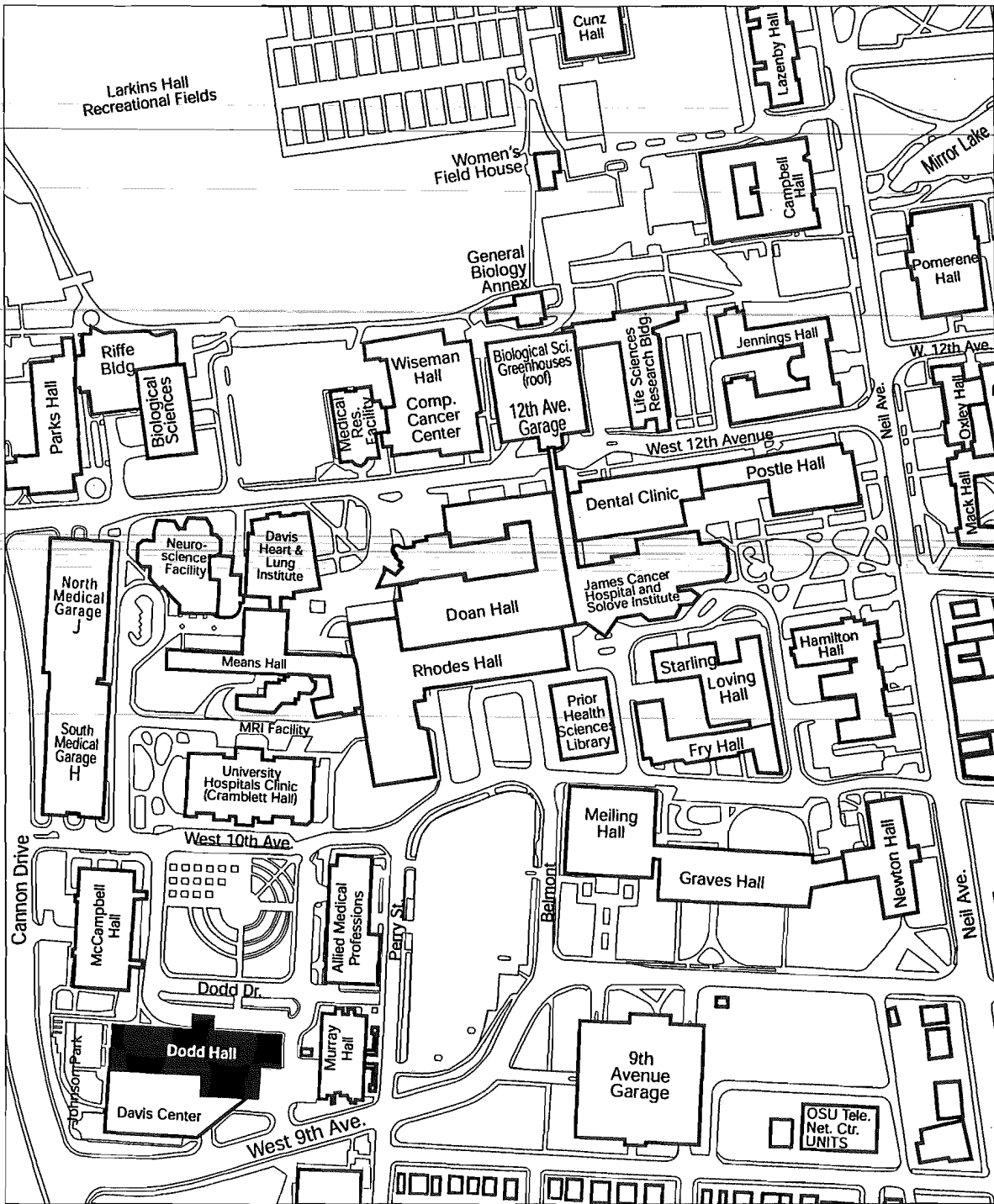

Office of Business and Finance
Office of Facilities Planning and Development

August 10, 2001



Evans Lab - Roof Replacement

315-1999-916

Requesting Agency(s): PHYSICAL FACILITIES

Location(s): EVANS LABORATORY, WILLIAM L.

Gross Sq. Ft.116,676 Age: 1960

Description: Replace all the built-up roofs on the 2nd, 4th, and 5th levels of the original building and the north addition.

Project Team:

Project Information:

Facility Planner: Is Unassigned

Project Captain: Scotty Pike
(pike.1@osu.edu)

Project Assistant: Karen Cogley
(cogley.1@osu.edu)

Field Coordinator: Scotty Pike
(pike.1@osu.edu)

Source of Funds:	Original	Revised	Uses of Funds:	As Designed	As Bid	Completion
HB850 Columbus Basic	\$325,000.00	\$325,000.00	Construction	\$344,000.00	\$269,000.00	\$0.00
Renovation			Contingency	\$25,265.00	\$25,265.00	\$0.00
Repair & Renovation	\$0.00	\$0.00	Design	\$26,700.00	\$26,700.00	\$0.00
Fiscal Yr 00-01			University Administration	\$5,160.00	\$4,035.00	\$0.00
Total:	\$325,000.00	\$325,000.00	Total:	\$401,125.00	\$325,000.00	\$0.00

Schedule:

Projected

Revised

Actual

Planning			
Arch/Engr Approved by B/T (\$325,000 Project)	02/05/1999		02/05/1999
Bidding Approved B/T (\$325,000 Project)	02/05/1999		02/05/1999
Design			
Schematic Design Approval	08/01/1999	09/12/2001	09/21/2001
Design Dev Document Approval	08/01/1999	09/12/2001	09/21/2001
Construction Document Approval	11/01/1999	12/01/2001	11/21/2001
Bidding			
Bid Opening	02/28/2000	02/28/2002	05/29/2002
Construction			
Award of Contracts	04/01/2000	09/10/2002	09/06/2002
Construction Start	04/10/2000	10/10/2002	09/11/2002
Report of Award to B/T (\$325,000 Project)	12/01/2000	02/07/2003	
Completion	10/10/2000	12/20/2002	12/20/2002

Evans Lab - Roof Replacement

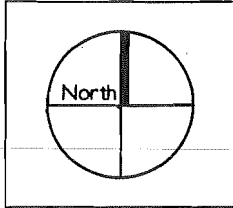
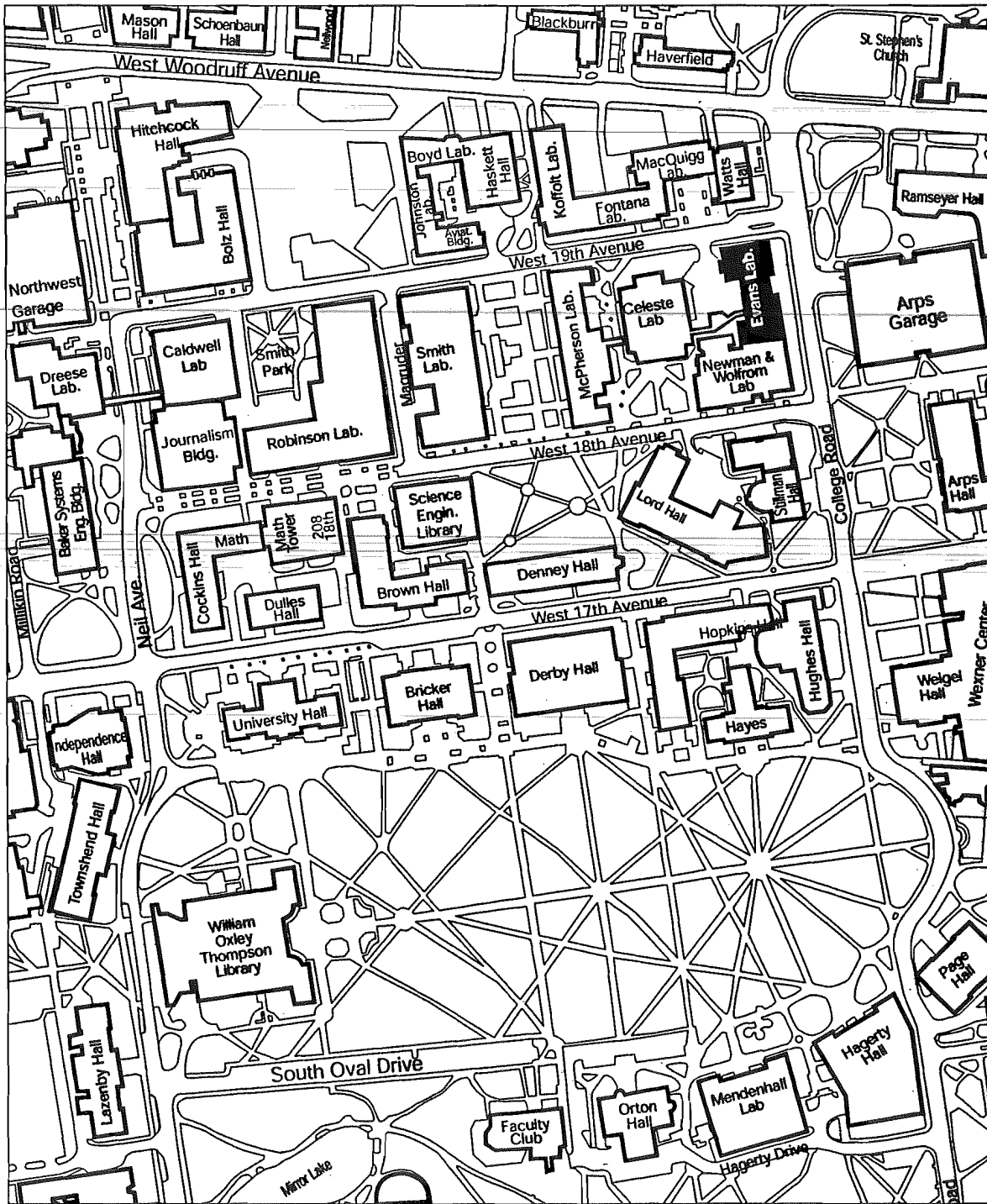

Office of Business and Finance
Office of Facilities Planning and Development

January 13, 2003



Golf Course - Men's Locker Room Renovation
315-1999-946

Requesting Agency(s): ATHLETICS

Location(s): GOLF COURSE SERVICE BLDG

Gross Sq. Ft. 3,576 Age: 1938

Description: Remodel the men's locker room and shoe repair area at the OSU golf course. This project will completely upgrade the locker area with new lockers, interior finish surfaces, HVAC system and new lighting. In addition, this project will develop a private locker area and a team meeting room for the OSU men's golf team with a new building entry to access the new team area.

Project Team:

Facility Planner: Anne Pensyl
(pensyl.3@osu.edu)

Project Captain: Thomas Heretta
(heretta.1@osu.edu)

Project Assistant: Curt Handschug
(handschug.1@osu.edu)

Field Coordinator: Is Unassigned

Project Information:

Formerly project number 5070-R981592.
Project was put on hold following receipt of original bids.

Source of Funds:	Original	Revised	Uses of Funds:	As Designed	As Bid	Completion
Auxiliaries-Athletics	\$435,000.00	\$465,108.30	Construction	\$446,400.00	\$367,770.00	\$0.00
Total:	\$435,000.00	\$465,108.30	Contingency	\$36,777.00	\$36,777.00	\$0.00
			Design	\$52,497.30	\$52,497.30	\$0.00
			University Administration	\$9,374.40	\$7,723.17	\$0.00
			Total:	\$545,048.70	\$464,767.47	\$0.00

Schedule:

	Projected	Revised	Actual
Planning			
Arch/Engr Approved by B/T (\$435,000 Project)	06/04/1999		06/04/1999
Bidding Approved B/T (\$435,000 Project)	06/04/1999		06/04/1999
Design			
Arch/Engr Contract	07/30/1999	12/15/1999	12/15/1999
Schematic Design Approval	10/15/1999	01/15/2000	01/15/2000
Design Dev Document Approval	10/15/1999	03/15/2000	03/15/2000
Construction Document Approval	02/01/2000	07/15/2000	07/15/2000
Bidding			
Bid Opening (Re-Bid Bid Opening)			09/04/2002
Bid Opening	08/01/2000	09/01/2000	08/24/2000
Construction			
Award of Contracts	09/01/2000	10/25/2002	10/18/2002
Construction Start	09/05/2000	11/15/2002	10/28/2002
Report of Award to B/T (\$464,767.47 Project)	12/01/2000	02/07/2003	
Completion	11/15/2000	04/17/2003	

Golf Course - Men's Locker Room Renovation

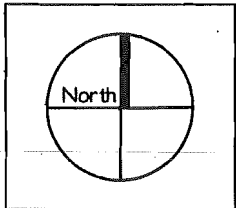
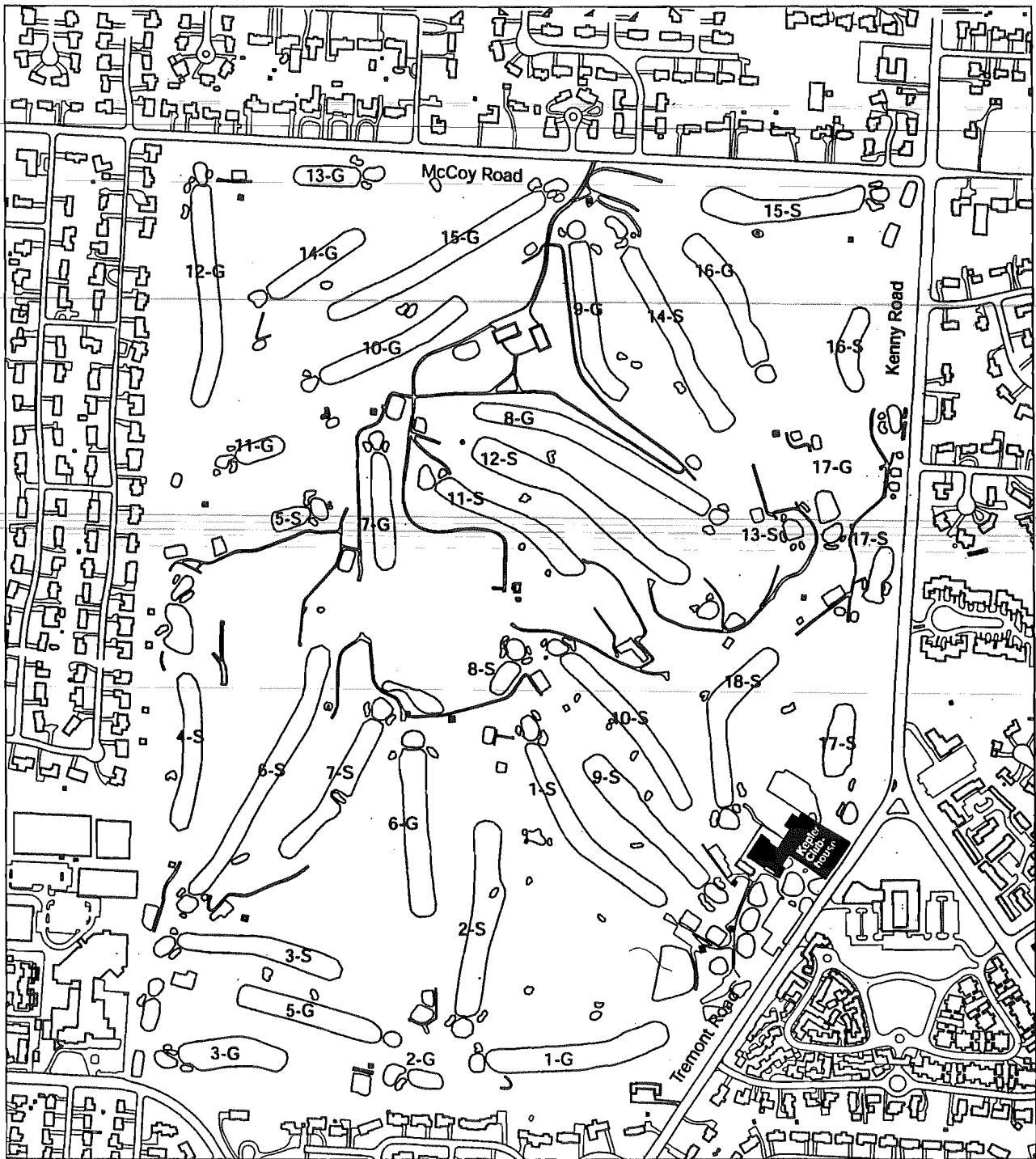

Office of Business and Finance
Office of Facilities Planning and Development

January 13, 2003



Goss Lab - Window Replacement

315-1996-931

Requesting Agency(s): PHYSICAL FACILITIES

Location(s): GOSS LABORATORY, LEONARD W.

Gross Sq. Ft.67,996 Age: 1962

Description: Replace the single glazed windows with insulated double glazed windows.

Project Team:

Facility Planner: Is Unassigned

Project Captain: Paul Sherwood
(Sherwood.1@osu.edu)

Project Assistant: Mikki Reese
(reese.153@osu.edu)

Field Coordinator: Glenn Gerhart
(gerhart.1@osu.edu)

Project Information:

Local administration approved by the Board of Regents on 8/5/96.

Design by Department of Physical Facilities personnel.

Source of Funds:	Original	Revised	Uses of Funds:	As Designed	As Bid	Completion
HB748 Columbus Basic	\$150,000.00	\$150,000.00	Construction	\$135,000.00	\$135,400.00	\$0.00
Renovation			Contingency	\$7,176.00	\$6,770.00	\$0.00
Total:	\$150,000.00	\$150,000.00	Design	\$5,799.00	\$5,799.00	\$0.00
			University Administration	\$2,025.00	\$2,031.00	\$0.00
			Total:	\$150,000.00	\$150,000.00	\$0.00

Schedule:

	Projected	Revised	Actual
Planning			
Arch/Engr Approved by B/T (\$150,000 Project)	12/08/1996		12/06/1996
Bidding Approved B/T (\$150,000 Project)	12/08/1996		12/06/1996
Design			
Schematic Design Approval	02/08/1997	02/23/1998	02/26/1998
Design Dev Document Approval	02/08/1997	02/23/1998	02/26/1998
Construction Document Approval	04/08/1997	01/15/1999	01/15/1999
Bidding			
Bid Opening	06/08/1997	05/30/2002	05/30/2002
Construction			
Award of Contracts	08/08/1997	09/13/2002	09/12/2002
Construction Start	08/31/1997	03/15/2003	
Report of Award to B/T (\$150,000 Project)	09/08/1997	02/07/2003	
Completion	11/30/1997	11/12/2003	

Goss Lab - Window Replacement

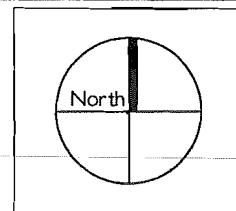
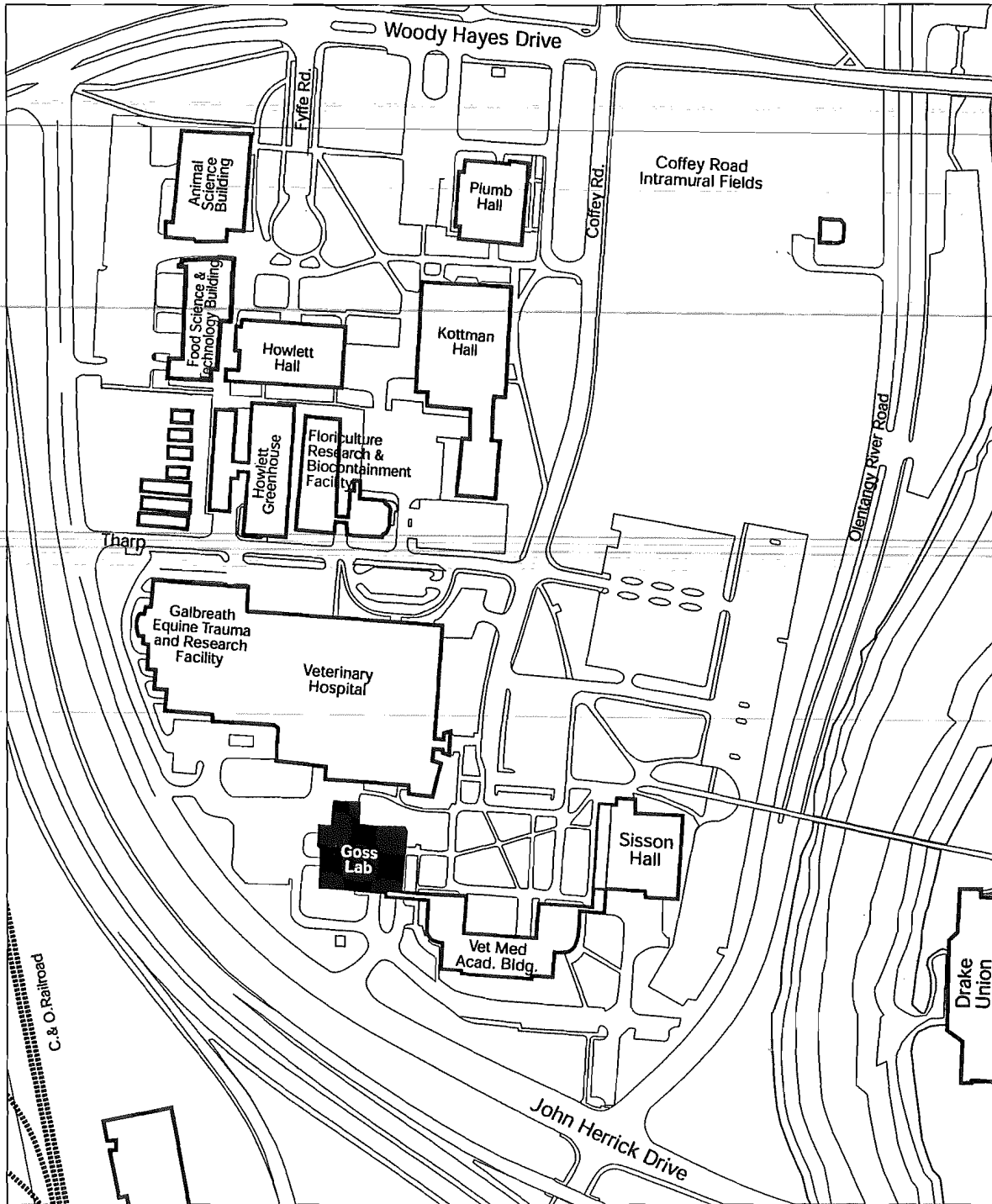

Office of Business and Finance
Office of Facilities Planning and Development

January 13, 2003



Graves Hall HVAC System Upgrades
315-2000-932

Requesting Agency(s): PHYSICAL FACILITIES

Location(s): GRAVES HALL, GRANT O

Gross Sq. Ft.220,370 Age: 1969

Description: This project would replace a 500 ton centrifugal chiller that utilizes obsolete R-11 refrigerant. The cooling tower that dates from 1969 would be replaced. Install a waterproof membrane in penthouse mechanical room floor.

Project Team:

Facility Planner: Is Unassigned

Project Captain: Colin McBride
(mcbride.62@osu.edu)

Project Assistant: Lisa Baldwin
(baldwin.10@osu.edu)

Field Coordinator: Is Unassigned

Project Information:

Design by Department of Physical Facilities' personnel.
\$8,487.40 additional funds added by the user during construction to cover requested changes.

Source of Funds:	Original	Revised	Uses of Funds:	As Designed	As Bid	Completion
HB640 Basic Renovations	\$1,040,505.00	\$550,000.00	Construction	\$492,500.00	\$483,905.00	\$0.00
Repair & Renovation	\$0.00	\$8,487.40	Contingency	\$49,050.00	\$55,650.00	\$0.00
Fiscal Yr 01-02			Design	\$3,088.00	\$3,088.00	\$0.00
			University Administration	\$7,387.50	\$7,357.00	\$0.00
Total:	\$1,040,505.00	\$558,487.40	Total:	\$552,025.50	\$550,000.00	\$0.00

Schedule:

	Projected	Revised	Actual
Planning			
Arch/Engr Approved by B/T (\$550,000 Project)	02/02/2001		02/02/2001
Bidding Approved B/T (\$550,000 Project)	02/02/2001		02/02/2001
Design			
Schematic Design Approval	09/15/2001		03/07/2001
Design Dev Document Approval	09/15/2001		03/07/2001
Construction Document Approval	01/01/2002		06/13/2001
Bidding			
Bid Opening	03/01/2002		11/16/2001
Construction			
Award of Contracts	05/01/2002		02/28/2002
Construction Start	10/01/2002		03/01/2002
Report of Award to B/T (\$550,000 Project)	12/01/2002	02/07/2003	
Completion	02/01/2003	07/29/2003	

Graves Hall - HVAC System Upgrades

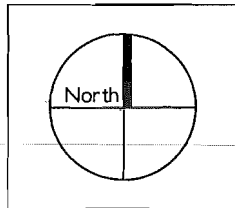
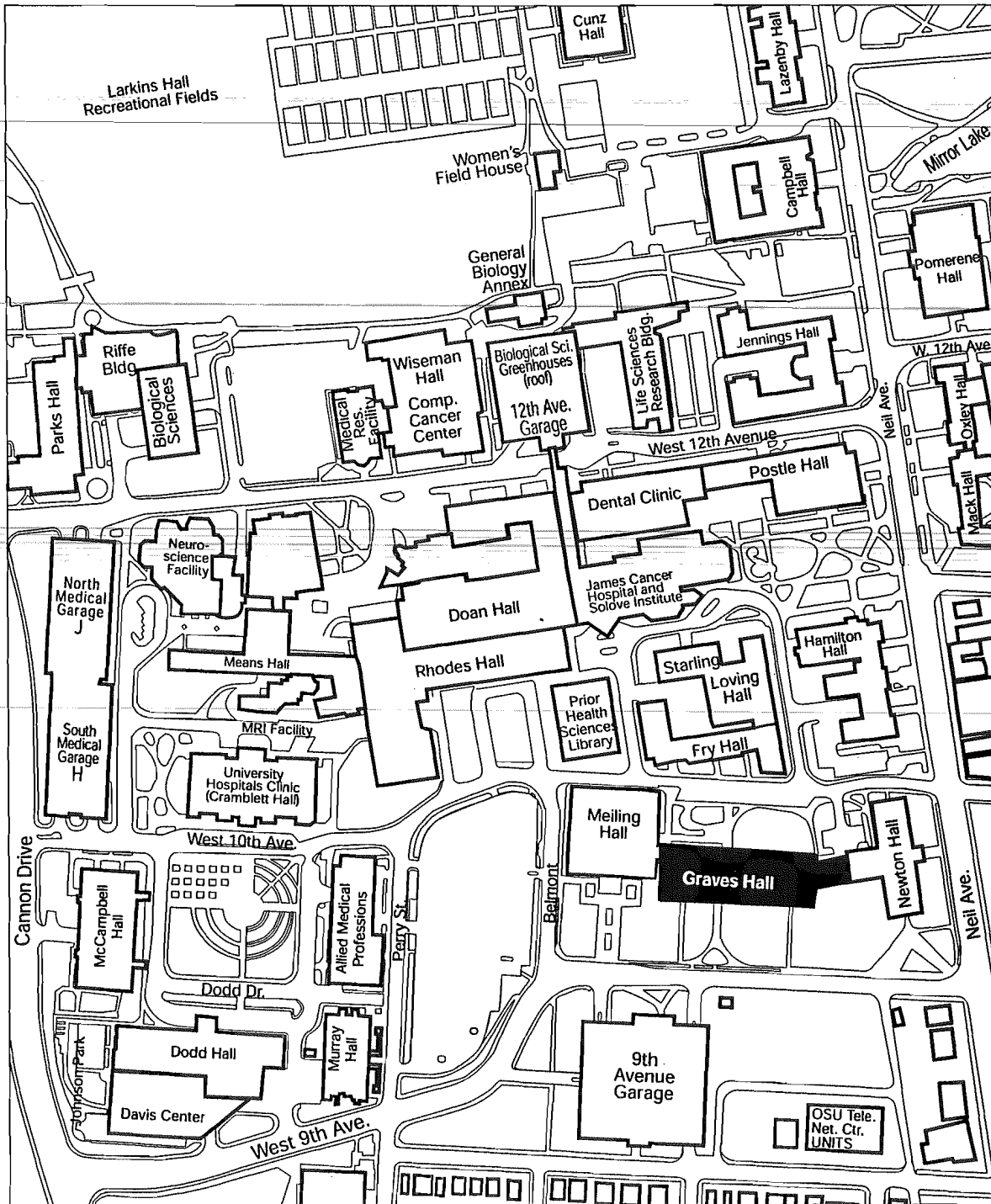

Office of Business and Finance
Office of Facilities Planning and Development

January 13, 2003



Graves Hall Roof Replacement
315-2000-942

Requesting Agency(s): PHYSICAL FACILITIES

Location(s): GRAVES HALL, GRANT O

Gross Sq. Ft.220,370 Age: 1969

Description: The existing built-up roof will be removed and new tapered ISO insulation and a modified bitumen roof membrane will be installed.

Project Team:

Facility Planner: Is Unassigned

Project Captain: Scotty Pike
(pike.1@osu.edu)

Project Assistant: Curt Handschug
(handschug.1@osu.edu)

Field Coordinator: Scotty Pike
(pike.1@osu.edu)

Project Information:

Being designed by outside consulting firm.
Bids came in below estimate, budget and funding adjusted accordingly

Source of Funds:	Original	Revised	Uses of Funds:	As Designed	As Bid	Completion
Repair & Renovation	\$0.00	\$0.00	Construction	\$238,950.00	\$197,600.00	\$0.00
Fiscal Yr 00-01			Contingency	\$23,895.00	\$19,760.00	\$0.00
HB640 Basic Renovations	\$300,000.00	\$245,224.00	Design	\$24,900.00	\$24,900.00	\$0.00
Total:	\$300,000.00	\$245,224.00	University Administration	\$3,584.00	\$2,964.00	\$0.00
			Total:	\$291,329.00	\$245,224.00	\$0.00

Schedule:	Projected	Revised	Actual
Planning			
Arch/Engr Approved by B/T (\$300,000 Project)	02/02/2001		02/02/2001
Bidding Approved B/T (\$300,000 Project)	02/02/2001		02/02/2001
Design			
Arch/Engr Contract	09/01/2001		12/27/2001
Schematic Design Approval	12/01/2001	03/01/2002	04/10/2002
Design Dev Document Approval	12/01/2001	03/01/2002	04/10/2002
Construction Document Approval	03/01/2002	04/01/2002	05/23/2002
Bidding			
Bid Opening	05/01/2002	09/02/2003	11/07/2002
Construction			
Award of Contracts	07/01/2002	02/01/2003	
Construction Start	07/15/2002	06/01/2003	
Report of Award to B/T (\$245,224 Project)	12/01/2002	02/07/2003	
Completion	10/15/2002	09/01/2003	

Graves Hall - Roof Replacement

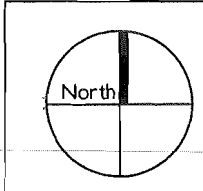
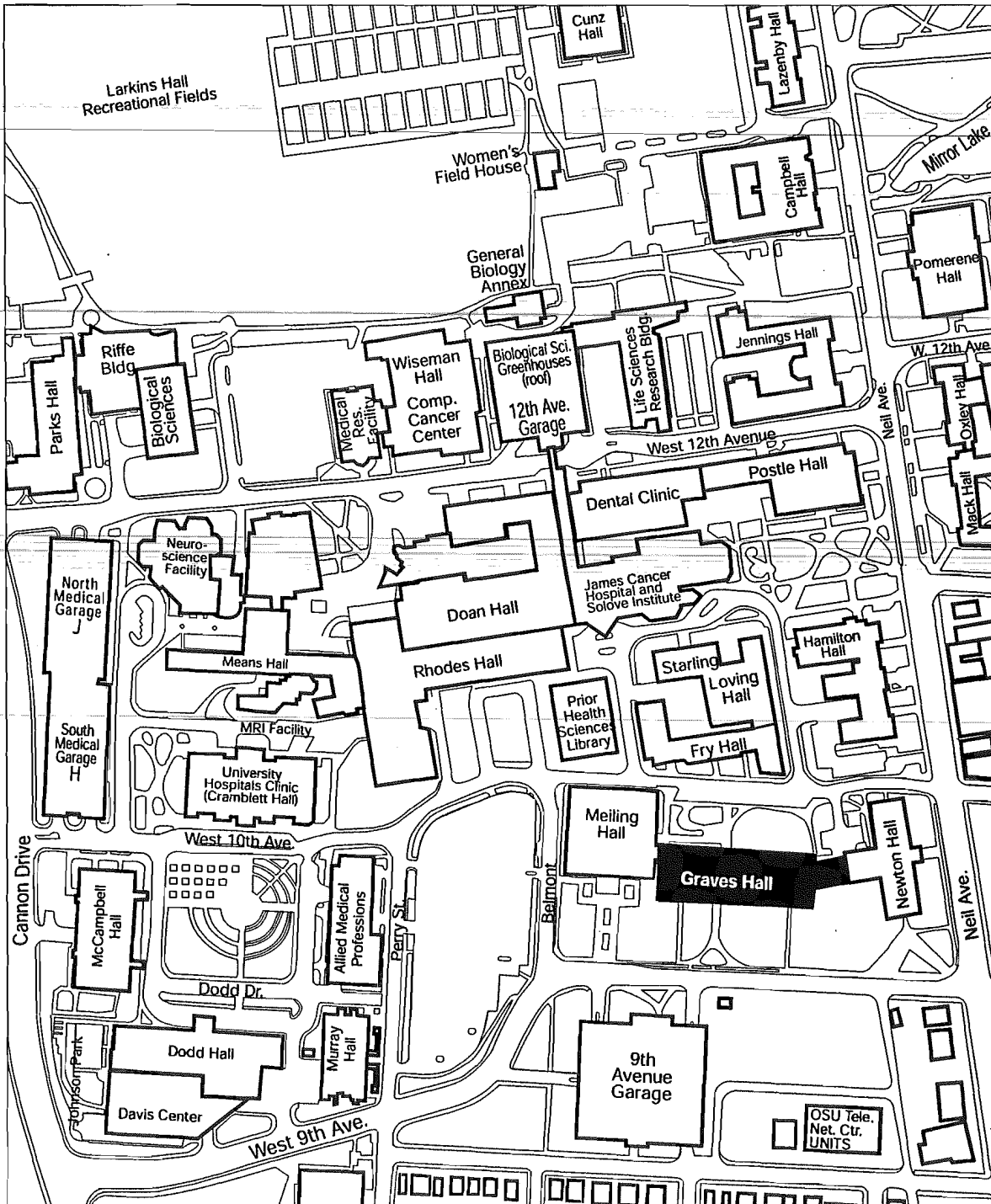

Office of Business and Finance
Office of Facilities Planning and Development

January 13, 2003



Hayes Hall Roof Replacement

315-2000-939

Requesting Agency(s): PHYSICAL FACILITIES

Location(s): HAYES HALL, RUTHERFORD B.

Gross Sq. Ft.43,969 Age: 1893

Description: The existing asphalt shingles will be removed and new roofing felts, ice and snow guard and slate tiles to match the building original will be installed. Also requires replacement of gutters and downspouts.

Project Team:

Facility Planner: Is Unassigned

Project Captain: Scotty Pike
(pike.1@osu.edu)

Project Assistant: Leeanne Chandler
(chandler.63@osu.edu)

Field Coordinator: Is Unassigned

Project Information:

The Department of Physical Facilities added \$37,500 during the design phase to cover the emergency temporary solutions and a permanent repair due to a previously unknown problem with a deteriorated roof truss on the building.

Source of Funds:	Original	Revised	Uses of Funds:	As Designed	As Bid	Completion
Repair & Renovation	\$0.00	\$0.00	Construction	\$471,114.00	\$387,098.00	\$0.00
Fiscal Yr 00-01			Contingency	\$22,235.53	\$22,235.53	\$0.00
HB640 Basic Renovatfons	\$420,000.00	\$420,000.00	Design	\$42,360.00	\$42,360.00	\$0.00
Repair & Renovation	\$0.00	\$37,500.00	University Administration	\$7,066.71	\$5,806.47	\$0.00
Fiscal Yr 01-02			Total:	\$542,776.24	\$457,500.00	\$0.00
Total:	\$420,000.00	\$457,500.00				

Schedule:

	Projected	Revised	Actual
Planning			
Arch/Engr Approved by B/T (\$420,000 Project)	02/02/2001		02/02/2001
Bidding Approved B/T (\$420,000 Project)	02/02/2001		02/02/2001
Design			
Arch/Engr Contract	07/01/2001		08/14/2001
Schematic Design Approval	10/01/2001	11/01/2001	10/29/2001
Design Dev Document Approval	10/01/2001	11/01/2001	10/29/2001
Construction Document Approval	01/01/2002	05/01/2002	03/12/2002
Bidding			
Bid Opening	03/01/2002	10/17/2002	10/17/2002
Construction			
Award of Contracts	05/01/2002	01/06/2003	01/03/2003
Construction Start	05/15/2002	06/16/2003	
Report of Award to B/T (\$457,500 Project)	12/01/2002	02/07/2003	
Completion	09/15/2002	10/16/2003	

Hayes Hall - Roof Replacement

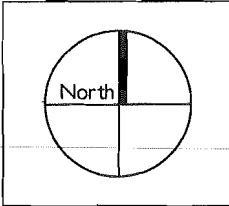
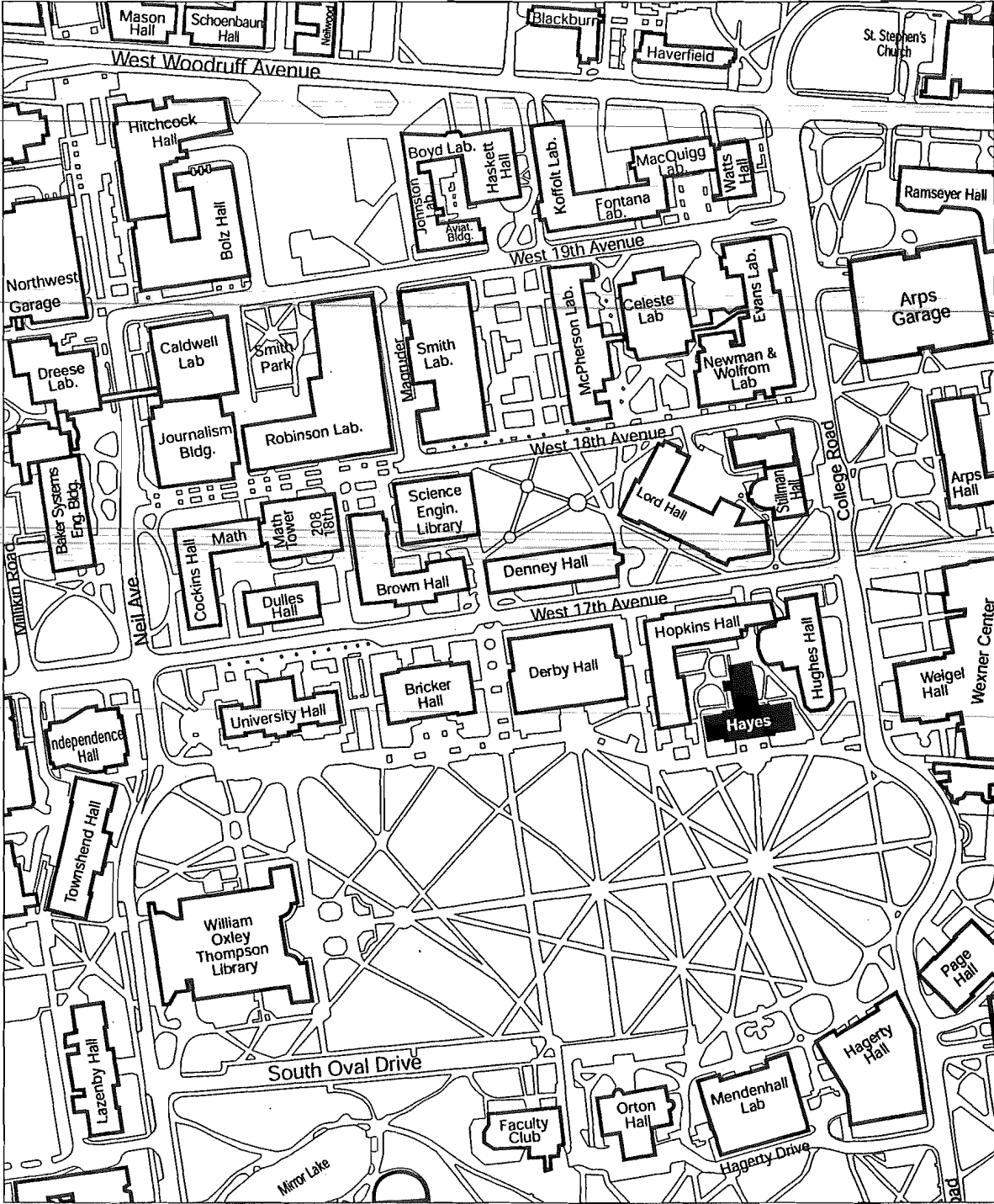

Office of Business and Finance
Office of Facilities Planning and Development

January 13, 2003



Koffolt and Fontana Labs Roof Replacement

315-1999-920

Requesting Agency(s): PHYSICAL FACILITIES

Location(s): KOFFOLT LABORATORIES, JOSEPH H

Gross Sq. Ft.83,726 Age: 1960

Location(s): FONTANA LABORATORIES, MARS G.

Gross Sq. Ft.32,296 Age: 1964

Description: Replace approximately 28,000 square feet of built-up roof, install new insulation, and remove and replace all metal flashings.

Project Team:

Facility Planner: Is Unassigned

Project Captain: Scotty Pike
(pike.1@osu.edu)

Project Assistant: Leeanne Chandler
(chandler.63@osu.edu)

Field Coordinator: Scotty Pike
(pike.1@osu.edu)

Project Information:

Source of Funds:	Original	Revised	Uses of Funds:	As Designed	As Bid	Completion
HB850 Columbus Basic	\$415,000.00	\$415,000.00	Construction	\$340,000.00	\$290,000.00	\$290,000.00
Renovation			Contingency	\$35,400.00	\$86,150.00	\$86,150.00
Total:	\$415,000.00	\$415,000.00	Design	\$34,500.00	\$34,500.00	\$34,500.00
			University Administration	\$5,100.00	\$4,350.00	\$4,350.00
			Total:	\$415,000.00	\$415,000.00	\$415,000.00

Schedule:

	Projected	Revised	Actual
Planning			
Arch/Engr Approved by B/T (\$415,000 Project)	02/05/1999		02/05/1999
Bidding Approved B/T (\$415,000 Project)	02/05/1999		02/05/1999
Design			
Arch/Engr Contract	08/30/1999		03/17/2000
Schematic Design Approval	03/01/2000	09/15/2000	09/08/2000
Design Dev Document Approval	03/01/2000	09/15/2000	09/08/2000
Construction Document Approval	05/01/2000	11/13/2000	11/13/2000
Bidding			
Bid Opening	10/31/2000	02/08/2002	01/15/2002
Construction			
Award of Contracts	11/30/2000	05/15/2002	04/02/2002
Construction Start	12/10/2000	05/29/2002	04/22/2002
Report of Award to B/T (\$415,000 Project)	12/01/2000	02/07/2003	
Completion	04/10/2001	08/29/2002	08/15/2002

Koffolt and Fontana Labs Roof Replacement

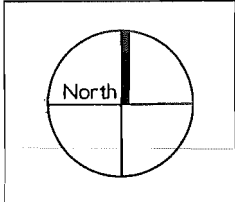
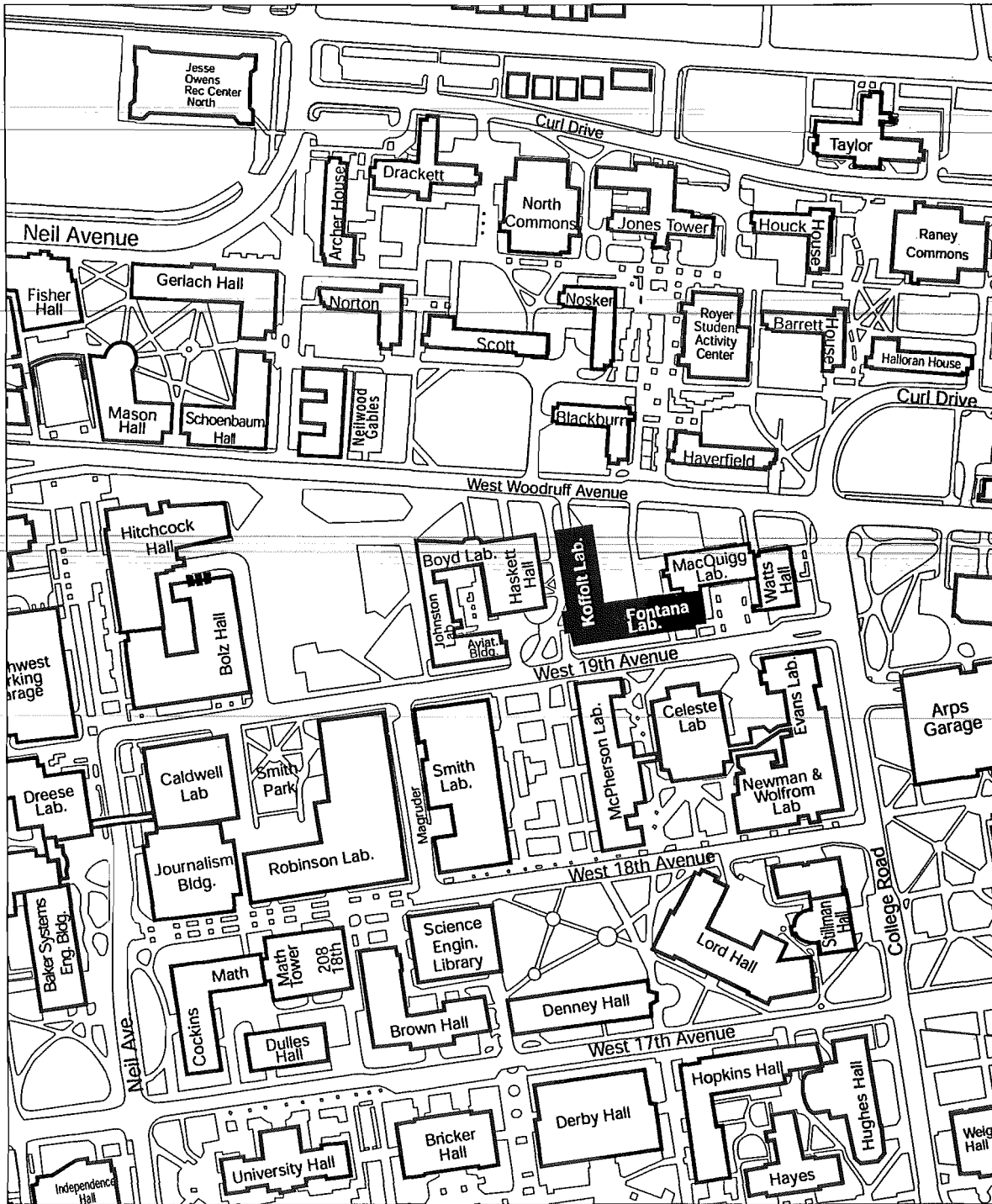

Office of Business and Finance
Office of Facilities Planning and Development

January 13, 2003



Lima Campus - 15KV Oil Switch Replacement

315-1999-955

Requesting Agency(s): LIMA CAMPUS

Location(s): Various Locations-Lima

Gross Sq. Ft.0 Age:

Description: Replace the 15KVA oil switches currently installed in Galvin Hall, Cooke Hall, and the Technical Education Laboratory to reinstate the reliability of the primary power system.

Project Team:

Facility Planner: Is Unassigned

Project Captain: Scott Conlon
(conlon.1@osu.edu)

Project Assistant: Curt Handschug
(handschug.1@osu.edu)

Field Coordinator: Is Unassigned

Project Information:

Excess funds from completed projects as listed below used to fund a portion of this project:

315-1994-951	\$12,480.52
315-1994-966	\$ 5,999.72
315-1993-465	\$18,397.58
315-1994-965	\$ 6,238.20

Source of Funds:	Original	Revised	Uses of Funds:	As Designed	As Bid	Completion
HB790 Regional Campuses	\$12,480.52	\$9,757.52	Construction	\$105,000.00	\$99,800.00	\$0.00
Basic			Contingency	\$10,500.00	\$9,980.00	\$0.00
HB904 Regional Campus	\$18,397.58	\$18,397.58	Design	\$11,000.00	\$11,000.00	\$0.00
Basic Renov			University Administration	\$1,575.00	\$1,497.00	\$0.00
HB808 Regional Campus	\$5,999.22	\$5,999.22	Total:	\$128,075.00	\$122,277.00	\$0.00
Basic Renov						
SB351 Regional Campuses	\$6,238.20	\$6,238.20				
Basic						
HB850 Regional Campuses	\$81,884.48	\$81,884.48				
Basic						
Total:	\$125,000.00	\$122,277.00				

Schedule:

	Projected	Revised	Actual
Planning			
Arch/Engr Approved by B/T (\$125,000 Project)	10/01/1999		10/01/1999
Bidding Approved B/T (\$125,000 Project)	10/01/1999		10/01/1999
Design			
Construction Document Approval	05/15/2000	04/01/2002	04/24/2002
Bidding			
Bid Opening	07/15/2000	08/01/2002	06/05/2002
Construction			
Award of Contracts	09/01/2000	08/19/2002	08/19/2002
Construction Start	09/15/2000	09/30/2002	10/04/2002
Report of Award to B/T (\$122,277 Project)	02/07/2003		
Completion	12/04/2002	02/28/2003	

Lima Campus - 15KV Oil Switch Replacement

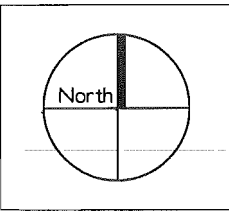
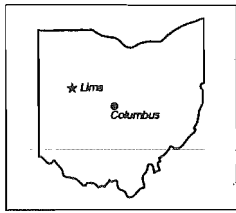
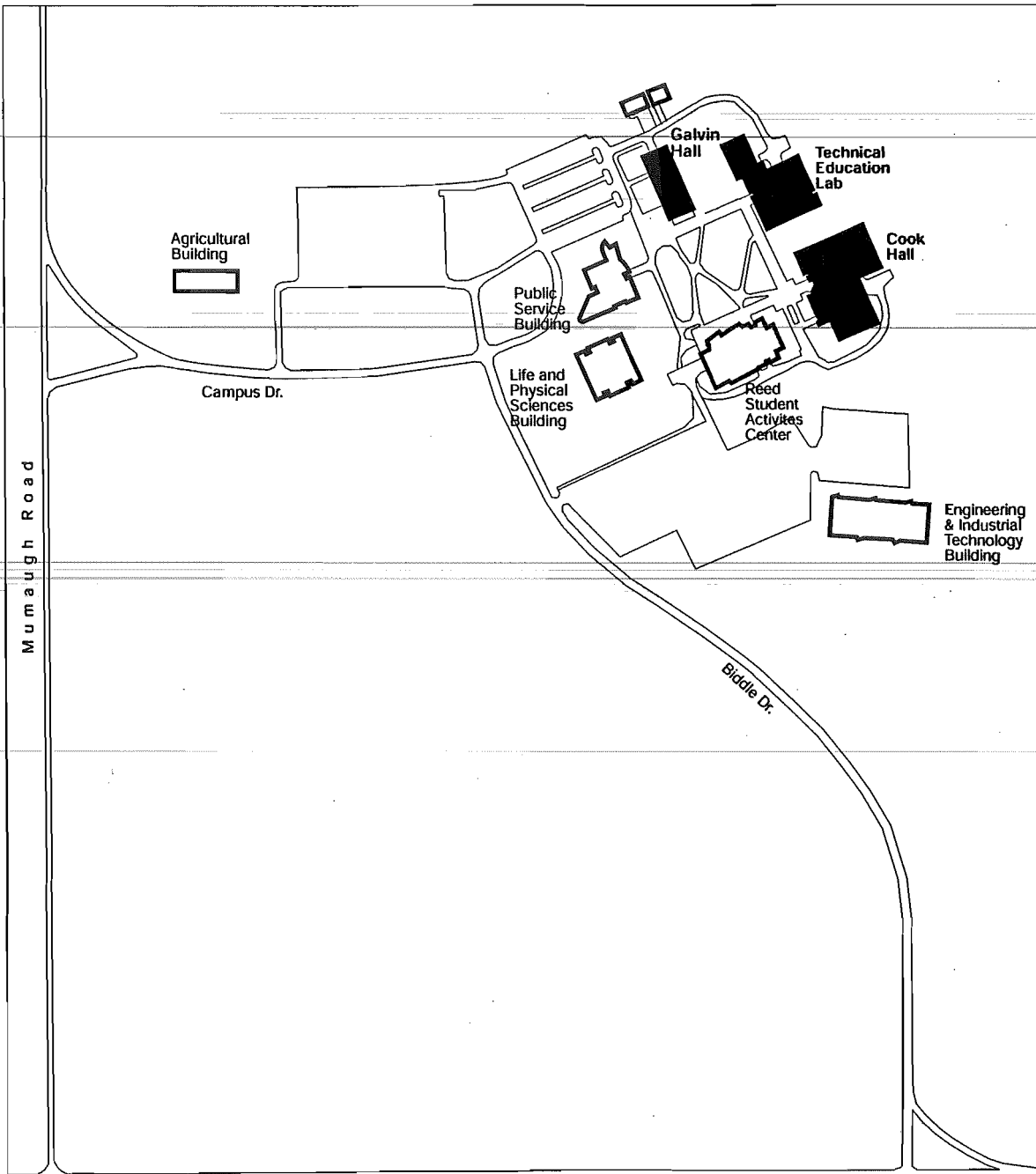

Office of Business and Finance
Office of Facilities Planning and Development

January 14, 2003



Mansfield Campus - Roadway & Parking Lot Resurfacing

315-2000-947

Requesting Agency(s): MANSFIELD CAMPUS

Location(s): Various Locations-Mansfield

Gross Sq. Ft.0 Age:

Description: Resurface approximately 1/2 mile long Mansfield main entrance roadway and heavily used parking lots (#4, #5, #6 and Tech Center). Work includes associated storm drain inlet repairs and striping.

Project Team:

Project Information:

Facility Planner: Is Unassigned
 Project Captain: Marty Bricker
 Project Assistant: Karen Cogley
 (cogley.1@osu.edu)
 Field Coordinator: Is Unassigned

Source of Funds:	Original	Revised	Uses of Funds:	As Designed	As Bid	Completion
HB748 Regional Campus	\$53,300.00	\$53,300.00	Construction	\$252,000.00	\$173,778.06	\$0.00
Line Items			Contingency	\$25,200.00	\$17,377.81	\$0.00
North Central Technical College	\$0.00	\$0.00	Design	\$44,500.00	\$44,500.00	\$0.00
HB640 Regional Basic Renovations	\$0.00	\$0.00	University Administration	\$3,780.00	\$2,606.67	\$0.00
HB640 Mansfield Basic Renovations	\$160,000.00	\$160,000.00	Total:	\$325,480.00	\$238,262.54	\$0.00
HB640 North Central Technical College	\$24,962.54	\$24,962.54				
Total:	\$238,262.54	\$238,262.54				

Schedule:

Projected

Revised

Actual

Planning			
Arch/Engr Approved by B/T (\$370,575 Project)	02/01/2002		02/01/2002
Bidding Approved B/T (\$370,575 Project)	02/01/2002		02/01/2002
Design			
Arch/Engr Contract	02/15/2002	10/09/2002	08/19/2002
Construction Document Approval	04/15/2002	08/20/2002	04/29/2002
Bidding			
Bid Opening	06/01/2002	09/20/2002	06/04/2002
Construction			
Award of Contracts	07/01/2002	10/21/2002	09/09/2002
Construction Start	07/01/2002	10/21/2002	09/09/2002
Report of Award to B/T (\$238,262.54 Project)	12/06/2002	02/07/2003	
Completion	09/15/2002	06/20/2003	

Mansfield Campus - Roadway and Parking Lot Resurfacing

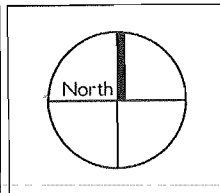
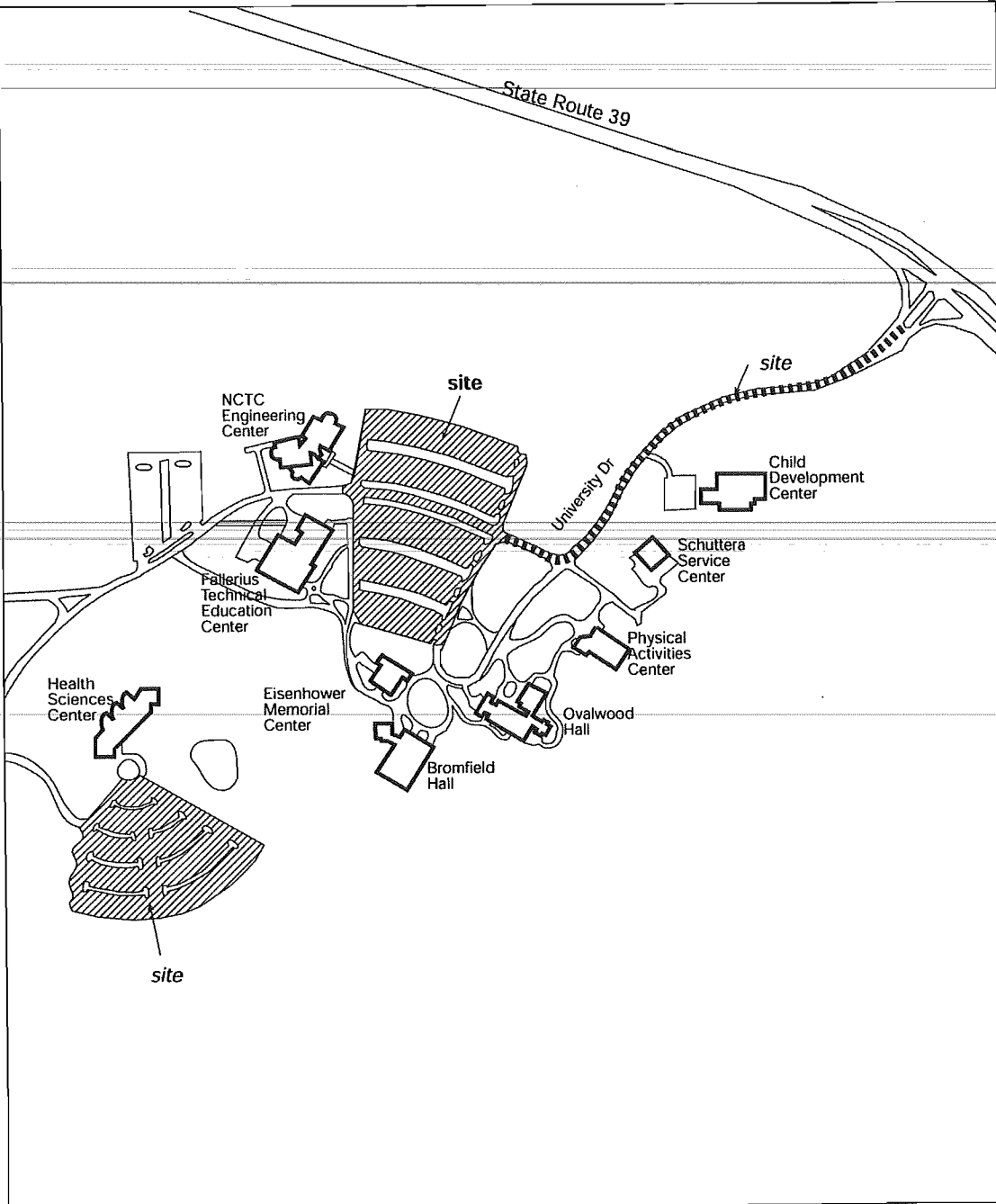

Office of Business and Finance
Office of Facilities Planning and Development

January 12, 2002



Mirror Lake Hollow Renovation

315-1999-923

Requesting Agency(s): PHYSICAL FACILITIES

Location(s): Unidentified Mall, Plaza, Green-Col.

Gross Sq. Ft.0 Age:

Description: Replace the wall of Mirror Lake and provide site improvements to sidewalks, steps, and landscaping.

Project Team:

Project Information:

Facility Planner: Is Unassigned

Project Captain: Gary Collier
(collier.26@osu.edu)

Project Assistant: Patricia Berger
(berger.58@osu.edu)

Field Coordinator: Colin McBride
(mcbride.62@osu.edu)

Source of Funds:	Original	Revised	Uses of Funds:	As Designed	As Bid	Completion
HB850 Columbus Basic	\$500,000.00	\$500,000.00	Construction	\$490,900.00	\$503,413.00	\$0.00
Renovation			Contingency	\$30,205.00	\$30,205.00	\$0.00
Repair & Renovation	\$0.00	\$285.00	Design	\$29,750.00	\$29,750.00	\$0.00
Fiscal Yr 00-01			University Administration	\$7,363.50	\$7,551.00	\$0.00
Repair & Renovation	\$70,634.00	\$70,634.00	Total:	\$558,218.50	\$570,919.00	\$0.00
Fiscal Yr 01-02						
Repair & Renovation	\$0.00	\$0.00				
Fiscal Yr 02-03						
Total:	\$570,634.00	\$570,919.00				

Schedule:

Projected

Revised

Actual

Planning			
Arch/Engr Approved by B/T (\$500,000 Project)	02/05/1999		02/05/1999
Bidding Approved B/T (\$500,000 Project)	02/05/1999		02/05/1999
Design			
Schematic Design Approval	06/15/1999	01/26/2001	01/26/2001
Design Dev Document Approval	08/15/1999	01/26/2001	01/26/2001
Construction Document Approval	12/01/1999	03/31/2001	03/23/2001
Bidding			
Bid Opening	02/28/2000	01/15/2002	01/09/2002
Construction			
Award of Contracts	04/01/2000	03/08/2002	03/15/2002
Construction Start	04/10/2000	04/01/2002	04/01/2002
Report of Award to B/T (\$570,919 Project)	12/01/2000	02/07/2003	
Completion	10/10/2000	02/28/2003	

Mirror Lake Hollow Renovation

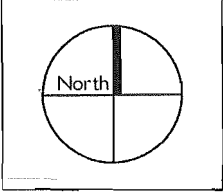
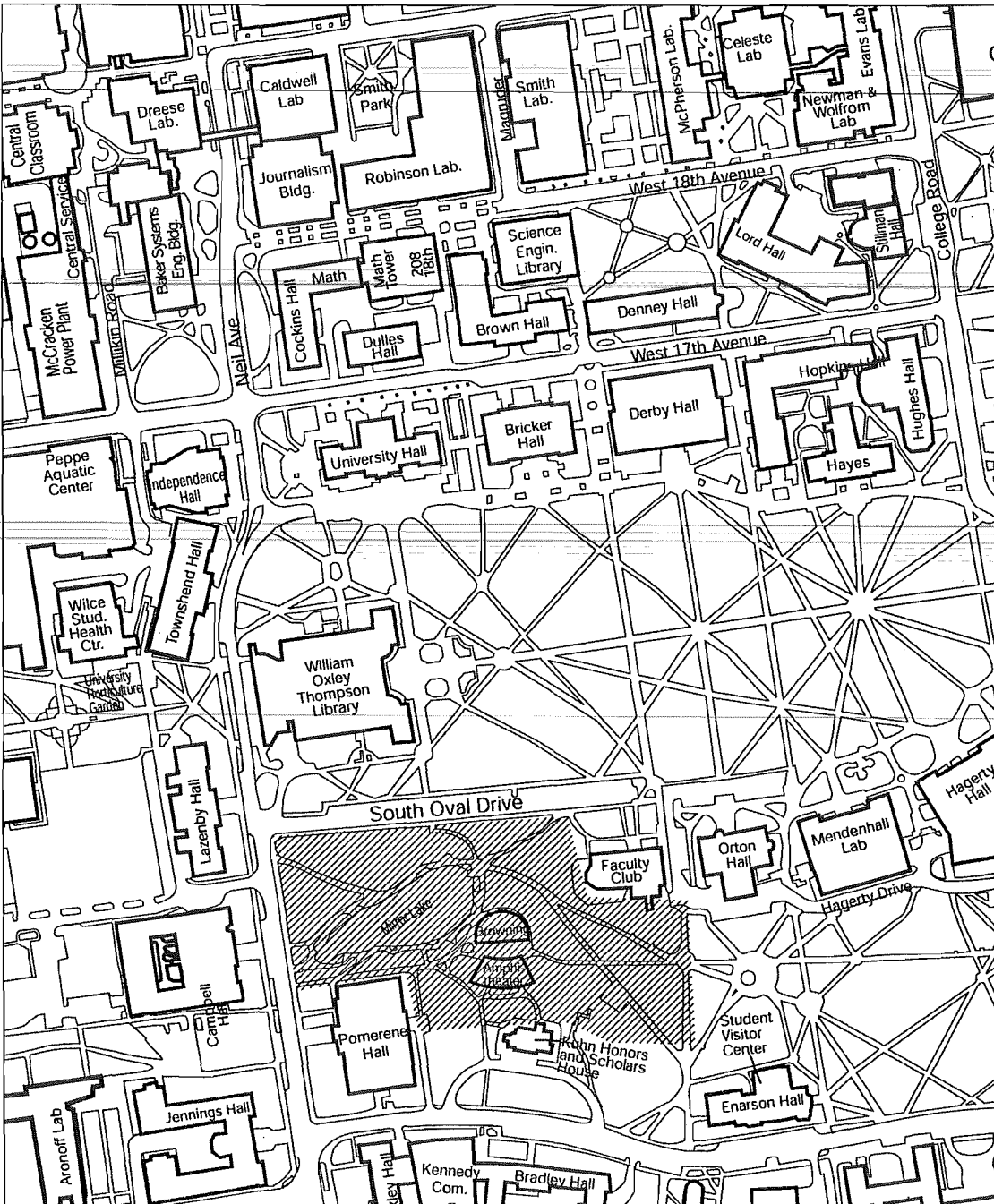

Office of Business and Finance
Office of Facilities Planning and Development

January 14, 2003



Multi-Purpose Turf Field

315-1999-188-2

Requesting Agency(s): RECREATIONAL SPORTS

Location(s): Unidentified Mall, Plaza, Green-Col.

Gross Sq. Ft.0 Age:

Description: Installation of a new 130 yard turf field sited on the northwest field of the Larkins four-field complex including installation of turf field lighting and filming platform. The outdoor artificial surface field will have a dual role in that it will not only be the practice field for the marching band but it will also be scheduled for club sports through the Department of Recreational Sports. Multiple field striping overlaid on top of each other, differentiated by color, will allow the field to be used for men's and women's soccer, lacrosse and field hockey, as well as flag football. In addition, the field will also be equipped with an outdoor lighting system which will extend the use of this field significantly.

Project Team:

Facility Planner: Cheryl Christie
(christie.2@osu.edu)
Project Captain: Dave Chapman
(chapman.123@osu.edu)
Project Assistant: Faye Bodyke
(bodyke.3@osu.edu)
Field Coordinator: Is Unassigned

Project Information:

Source of Funds:	Original	Revised	Uses of Funds:	As Designed	As Bid	Completion
Development-Athletics	\$140,000.00	\$106,995.00	Construction	\$993,426.00	\$767,822.00	\$0.00
Development-Business & Admin	\$671,000.00	\$512,652.00	Contingency	\$136,804.61	\$73,779.94	\$0.00
General Funds-Business & Admin	\$150,000.00	\$114,625.00	Design	\$79,868.00	\$79,868.00	\$0.00
Future Univ. Bond Issues	\$264,000.00	\$201,718.00	University Administration	\$14,901.39	\$14,520.06	\$0.00
UNRESTRICTED GIFT MONIES	\$0.00	\$0.00	Total:	\$1,225,000.00	\$935,990.00	\$0.00
Total:	\$1,225,000.00	\$935,990.00				



Multi-Purpose Turf Field
315-1999-188-2

Schedule:	Projected	Revised	Actual
Planning			
Arch/Engr Approved by B/T (\$1,225,000 Project)	03/01/2002		03/01/2002
Bidding Approved B/T (\$1,225,000 Project)	03/01/2002		03/01/2002
Design			
Construction Document Approval	02/26/2002		03/25/2002
Bidding			
Bid Opening (Rebid Site Work)	06/11/2002		06/11/2002
Bid Opening	04/16/2002	06/11/2002	04/24/2002
Construction			
Award of Contracts	06/04/2002	07/30/2002	08/09/2002
Construction Start	06/11/2002	08/15/2002	08/21/2002
Report of Award to B/T (\$933,686.06 Project)	07/12/2002	02/07/2003	
Completion	09/17/2002	02/19/2003	

Multi-Purpose Turf Field

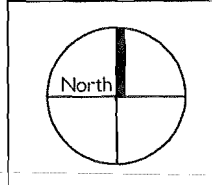
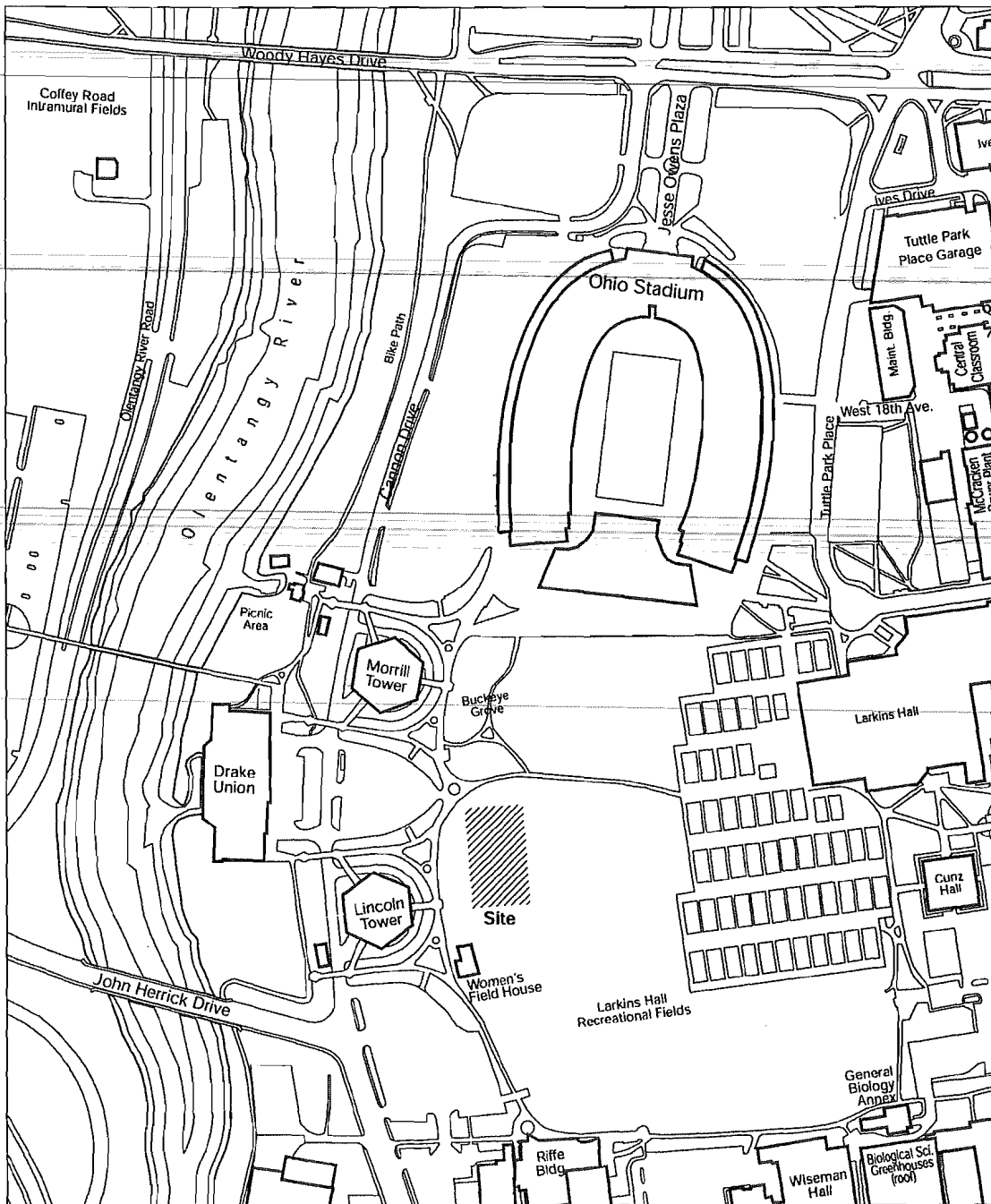

Office of Business and Finance
Office of Facilities Planning and Development

January 14, 2003



OARnet - HVAC & Electrical Improvements

315-2002-919

Requesting Agency(s): OARNET

Location(s): Site - See Comments.

Gross Sq. Ft.0 Age:

Description: Install UPS system, generator, HVAC and new 3-phase 208-volt service at 1454 West Lane Avenue

Project Team:

Project Information:

Facility Planner: Is Unassigned

Project Captain: Colin McBride
(mcbride.62@osu.edu)

Project Assistant: Steve Deedrick
(deedrick.4@osu.edu)

Field Coordinator: Is Unassigned

Source of Funds:	Original	Revised	Uses of Funds:	As Designed	As Bid	Completion
Board of Regents	\$250,616.00	\$208,588.63	Construction	\$224,768.00	\$187,075.00	\$0.00
Total:	\$250,616.00	\$208,588.63	Contingency	\$22,476.80	\$18,707.50	\$0.00
			University Administration	\$3,371.52	\$2,806.13	\$0.00
			Total:	\$250,616.32	\$208,588.63	\$0.00

Schedule:

Projected

Revised

Actual

Planning			
Bidding Approved B/T (\$250,616 Project)	07/12/2002		07/12/2002
Design			
Schematic Design Approval	07/24/2002		07/24/2002
Design Dev Document Approval	07/24/2002		07/24/2002
Construction Document Approval	07/24/2002		07/24/2002
Bidding			
Bid Opening	08/01/2002		08/06/2002
Construction			
Award of Contracts	09/25/2002	10/18/2002	10/18/2002
Construction Start	09/30/2002	11/04/2002	11/04/2002
Report of Award to B/T (\$208,588.63 Project)	12/01/2002	02/07/2003	
Completion	11/29/2002	02/04/2003	

OARnet - HVAC and Electrical Improvements

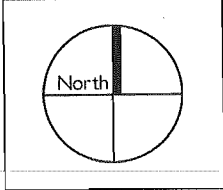
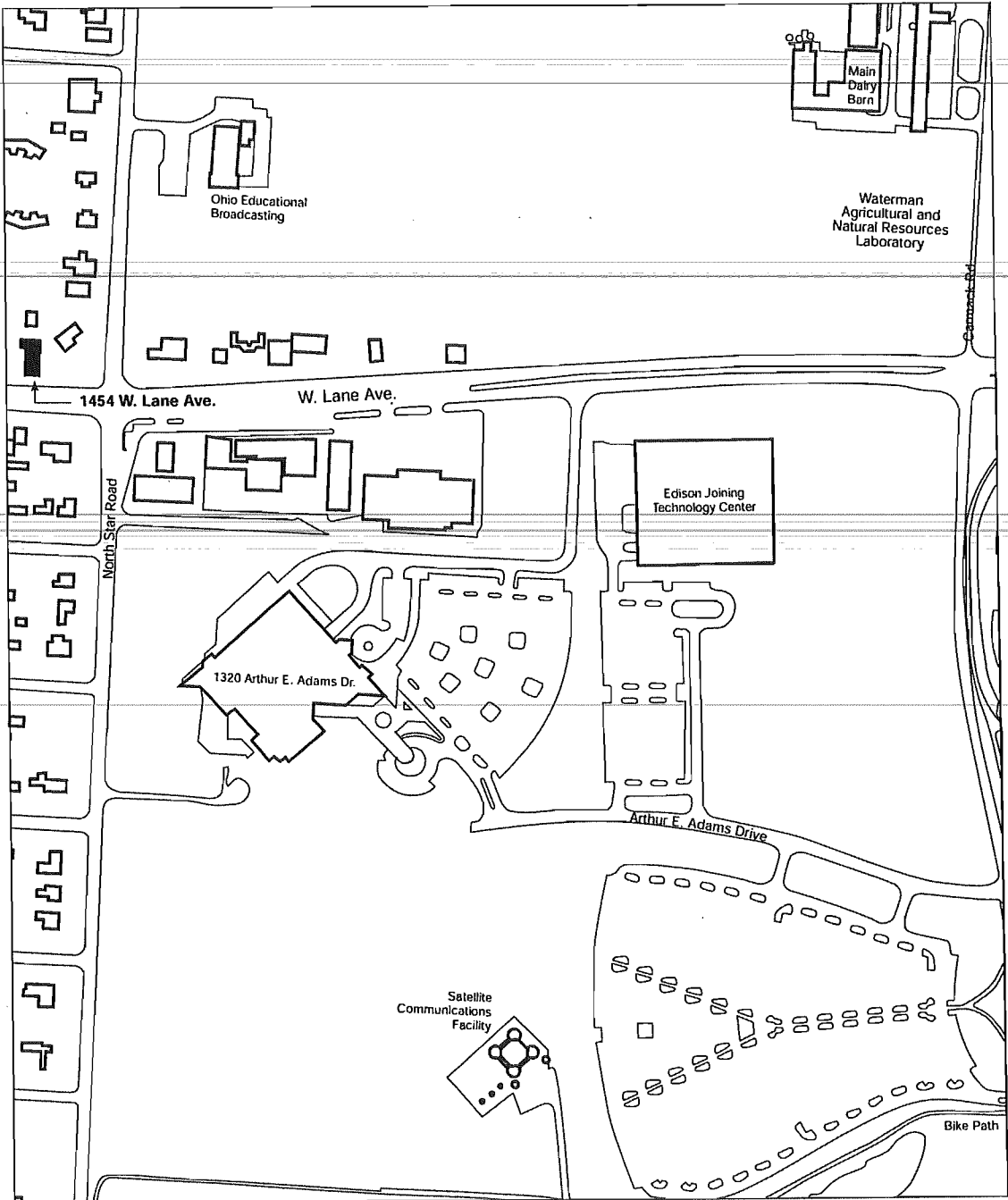

Office of Business and Finance
Office of Facilities Planning and Development

June 27, 2002



Orton Hall Roof Replacement
315-1999-925

Requesting Agency(s): PHYSICAL FACILITIES

Location(s): ORTON HALL, EDWARD SR

Gross Sq. Ft.39,799 Age: 1893

Description: Replace the existing asphalt tile shingles with new clay tile as originally installed. Replace the existing graduated clay tile on the bell tower with new graduated clay tile. Replace the building gutter with new copper metal.

Project Team:

Facility Planner: Is Unassigned

Project Captain: Scotty Pike
(pike.1@osu.edu)

Project Assistant: Lisa Baldwin
(baldwin.10@osu.edu)

Field Coordinator: Scotty Pike
(pike.1@osu.edu)

Project Information:

Source of Funds:	Original	Revised	Uses of Funds:	As Designed	As Bid	Completion
HB790 Columbus Basic	\$0.00	\$149,725.00	Construction	\$643,634.38	\$601,440.00	\$0.00
Renovation			Contingency	\$32,181.72	\$30,072.40	\$0.00
HB850 Columbus Basic	\$540,000.00	\$540,000.00	Design	\$56,900.00	\$56,900.00	\$0.00
Renovation			University Administration	\$9,654.52	\$9,021.60	\$0.00
Repair & Renovation	\$0.00	\$0.00	Total:	\$742,370.62	\$697,434.00	\$0.00
Fiscal Yr 00-01						
Total:	\$540,000.00	\$689,725.00				

Schedule:	Projected	Revised	Actual
Planning			
Arch/Engr Approved by B/T (\$540,000 Project)	02/05/1999	01/29/2000	02/05/1999
Bidding Approved B/T (\$540,000 Project)	02/05/1999		02/05/1999
Design			
Arch/Engr Contract	07/30/1999	11/15/1999	08/31/2000
Schematic Design Approval	09/15/1999	10/31/2000	10/24/2000
Design Dev Document Approval	09/15/1999	10/31/2000	10/24/2000
Construction Document Approval	01/01/2000	03/20/2001	03/20/2001
Bidding			
Bid Opening	03/31/2000	02/28/2002	04/25/2002
Construction			
Award of Contracts	05/31/2000	05/01/2002	07/08/2002
Construction Start	06/10/2000	05/15/2002	07/13/2002
Report of Award to B/T (\$697,434 Project)	12/01/2000	02/07/2003	
Completion	12/10/2000	02/28/2003	

Orton Hall Roof Replacement

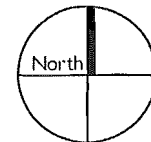
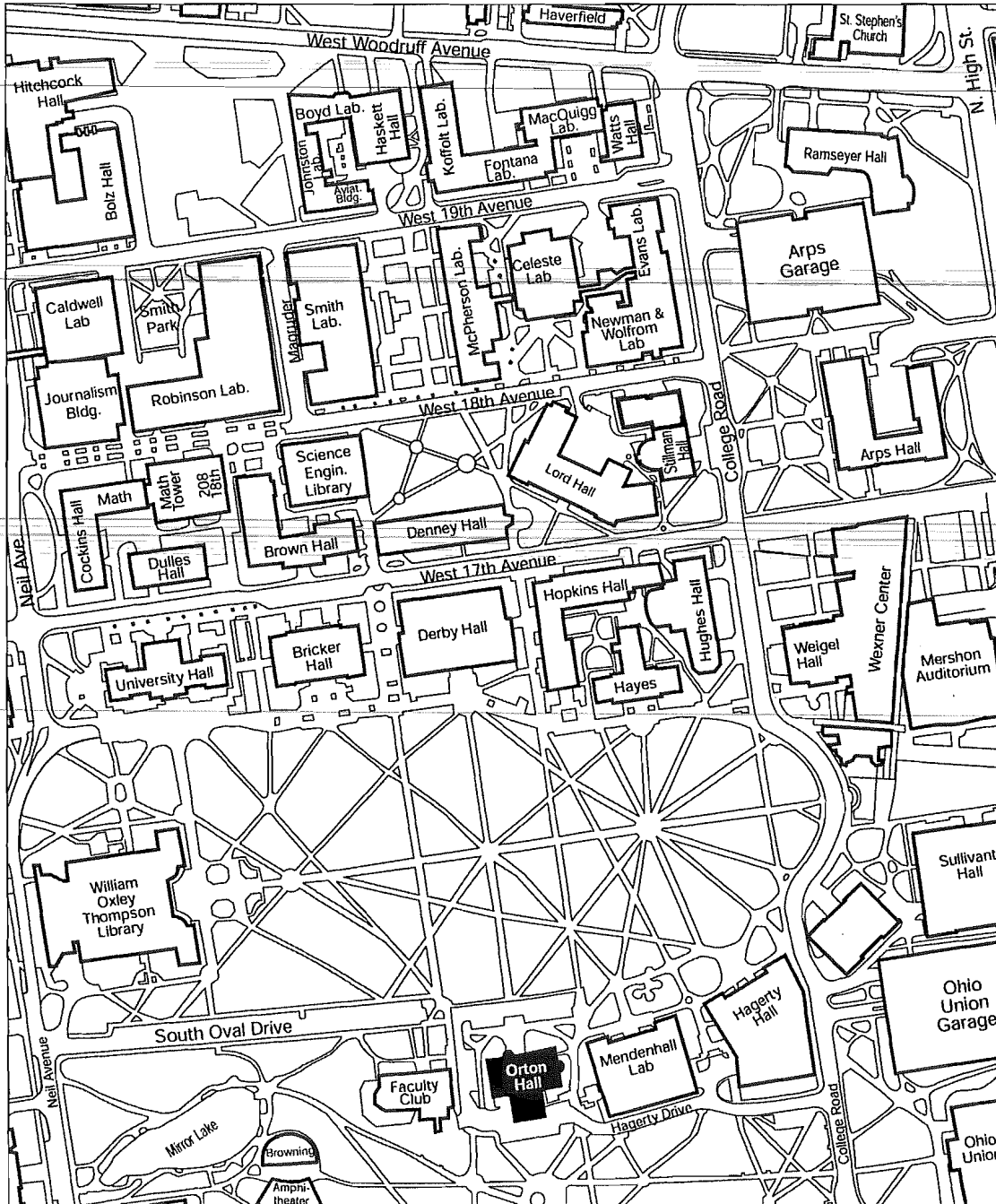

Office of Business and Finance
Office of Facilities Planning and Development

January 13, 2003



Requesting Agency(s): ACADEMIC AFFAIRS, OFFICE OF

Location(s): PAGE HALL, HENRY FOLSOM

Gross Sq. Ft.50,550 Age: 1902

Description: Renovation of Page Hall following relocation of College of Business to house the John Glenn Institute. It is anticipated that Public Policy and Management and Physical Facilities Shop will also be located in Page Hall.

Project Team:

Facility Planner: Teresa Yu
(yu.195@osu.edu)
Project Captain: Ruth Miller
(miller.2495@osu.edu)
Project Assistant: Mikki Reese
(reese.153@osu.edu)
Field Coordinator: Is Unassigned

Project Information:

Local administration granted as per the letter dated 7/22/99.
Project increased due to the John Glenn Institute commitment to provide additional fund raising in the amount of \$5 million.

Source of Funds:	Original	Revised	Uses of Funds:	As Designed	As Bid	Completion
Development-Social & Behav Sci	\$0.00	\$0.00	Construction	\$11,431,975.00	\$11,648,305.00	\$0.00
Development-Academic Affairs	\$0.00	\$5,000,000.00	Contingency	\$1,209,142.81	\$990,416.37	\$0.00
Future Capital	\$10,000,000.00	\$0.00	Design	\$1,183,709.00	\$1,183,709.00	\$0.00
Appropriations			Equipment	\$2,037,200.00	\$1,924,590.82	\$0.00
H8850 Line Item	\$700,000.00	\$700,000.00	Percent for Art	\$153,000.00	\$103,000.00	\$0.00
Appropriation			State Architect	\$40,000.00	\$40,000.00	\$0.00
HB640 Line Item	\$0.00	\$10,300,000.00	University Administration	\$107,274.69	\$109,978.81	\$0.00
Appropriation			Total:	\$16,162,301.50	\$16,000,000.00	\$0.00
Total:	\$10,700,000.00	\$16,000,000.00				



Schedule:	Projected	Revised	Actual
Planning			
Arch/Engr Approved by B/T (\$700,000 Planning)	02/05/1999		02/05/1999
Bidding Approved B/T (\$16,000,000 Project)	11/01/2000	05/03/2002	05/03/2002
Design			
Arch/Engr Contract	03/09/2000		03/09/2000
Schematic Design Approval	02/01/2001	06/05/2001	07/24/2001
Design Dev Document Approval	06/01/2001	12/12/2001	12/12/2001
Construction Document Approval	01/03/2002	09/16/2002	09/16/2002
Bidding			
Bid Opening (Asbestos Bid Pkg)	03/14/2002	04/04/2002	04/04/2002
Bid Opening	03/01/2002	12/12/2002	12/12/2002
Construction			
Award of Contracts	07/01/2002	03/21/2003	
Construction Start	07/07/2002	04/01/2003	
Report of Award to B/T (\$16,000,000 Project)	07/01/2002	03/19/2003	
Completion	02/01/2004	09/14/2004	
FF&E			
FF&E Program Review	07/24/2001		07/24/2001
FF&E Design Dev Document Approval	01/04/2002	06/28/2002	06/28/2002
FF&E Schematic Document Approval	08/16/2001		08/16/2001
FF&E Contract Document Approval	10/18/2002	03/01/2003	
FF&E Final Quotes From Contracts	12/31/2002	03/14/2003	
FF&E Purchasing	04/04/2003	04/24/2003	
FF&E Purchase Order Issuance	04/11/2003	06/24/2003	
FF&E Pre-installation Meeting	05/28/2004	08/10/2004	
FF&E Installation	08/31/2004	09/15/2004	
OSU-Tech Equip Installation	09/10/2004	10/08/2004	

Page Hall Renovation

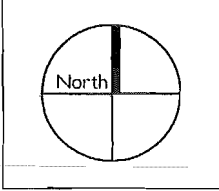
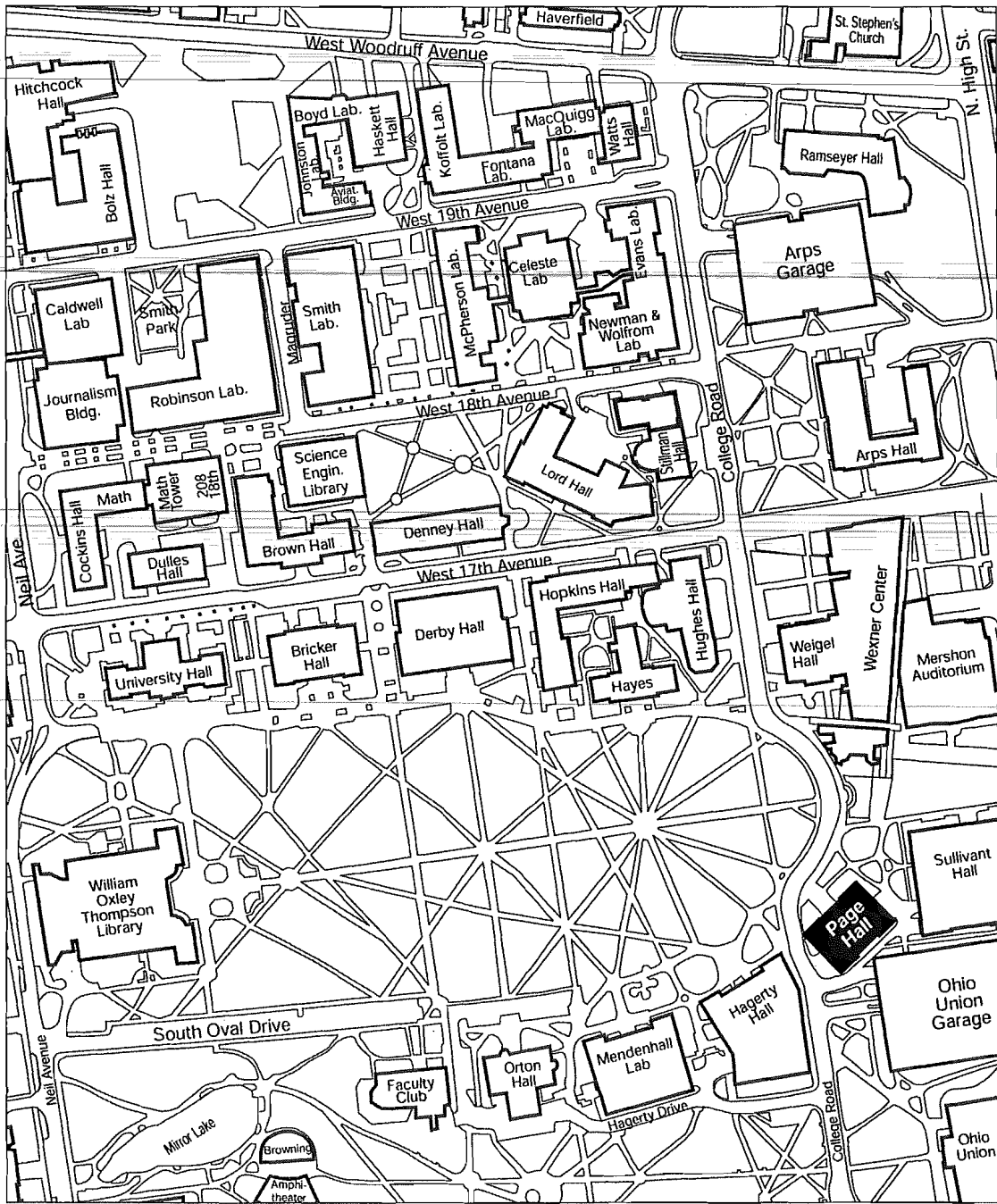

Office of Business and Finance
Office of Facilities Planning and Development

December 9, 2000



Parker Food Science - Pilot Plant Facility

315-2000-918

Requesting Agency(s): FOOD SCIENCE & TECHNOLOGY

Location(s): PARKER FOOD SCIENCE & TECHNOLOGY

Gross Sq. Ft.67,562 Age: 2000

BLD

Description: Construct a Pulsed Electrical Field Research and Development Pilot Plant Facility in the basement of the Food Science and Technology Building.

Project Team:

Facility Planner: Joyce Minor
(minor.6@osu.edu)
Project Captain: John Frazier
(frazier.2@osu.edu)
Project Assistant: Karen Cogley
(cogley.1@osu.edu)
Field Coordinator: Is Unassigned

Project Information:

Additional funds added to the project during design to more accurately reflect the scope of the work being accomplished.

Source of Funds:	Original	Revised	Uses of Funds:	As Designed	As Bid	Completion
Other	\$36,000.00	\$70,000.00	Construction	\$650,000.00	\$577,500.00	\$577,500.00
Restricted-Research			Contingency	\$38,855.00	\$38,892.50	\$38,855.00
General Funds-Agriculture	\$0.00	\$167,000.00	Design	\$33,945.00	\$33,945.00	\$33,945.00
Admin			University Administration	\$9,750.00	\$8,662.50	\$8,700.00
BOR Action Fund	\$132,000.00	\$0.00	Total:	\$732,550.00	\$659,000.00	\$659,000.00
General Funds-Food, Agr & Env Sci	\$280,000.00	\$0.00				
Development-Food, Agr & Env Sciences	\$52,000.00	\$422,000.00				
Total:	\$500,000.00	\$659,000.00				

Schedule:

	Projected	Revised	Actual
Planning			
Arch/Engr Approved by B/T (\$500,000 Project)	05/04/2001		05/04/2001
Bidding Approved B/T (\$500,000 Project)	05/04/2001		05/04/2001
Bidding			
Bid Opening	11/09/1999		11/09/1999
Construction			
Construction Start	02/01/2002		02/01/2002
Report of Award to B/T (\$659,000 Project)	06/07/2002	02/07/2003	
Completion	05/15/2002	09/30/2002	09/30/2002

Parker Food Science - Pilot Plant Facility

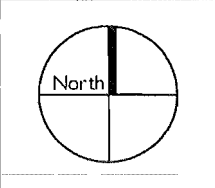
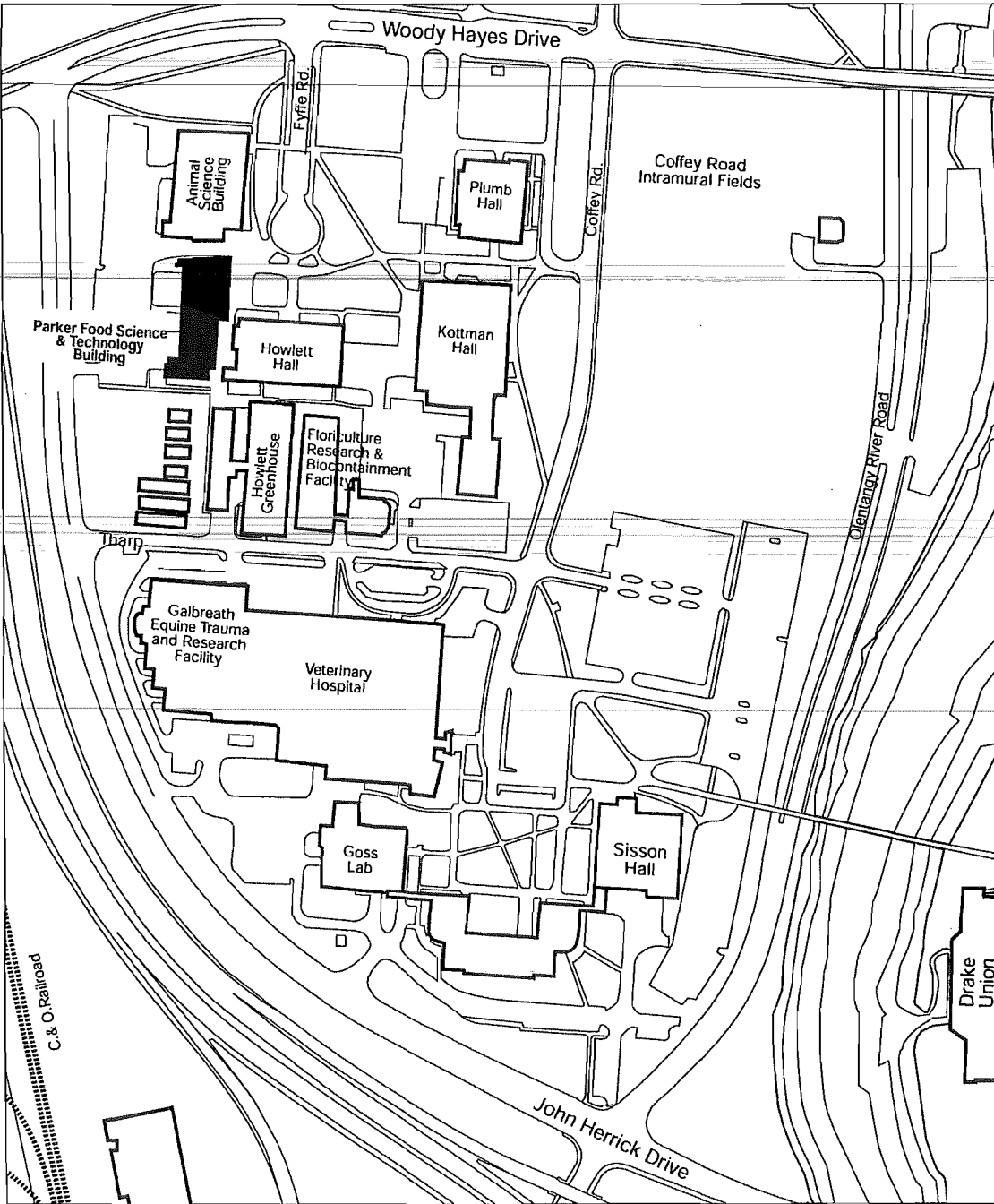

Office of Business and Finance
Office of Facilities Planning and Development

April 17, 2001



Physical Sciences Research Building

315-1999-195

Requesting Agency(s): MATHEMATICAL & PHYSICAL SCIENCES ADMIN

Location(s): Site - See Comments.

Gross Sq. Ft.0 Age:

Description: Provide new or renovated facilities for the Department of Physics.

Project Team:

Facility Planner: Anne Pensyl
(pensyl.3@osu.edu)
Project Captain: Chuck Hamilton
(hamilton.6@osu.edu)
Project Assistant: Steve Deedrick
(deedrick.4@osu.edu)
Field Coordinator: Is Unassigned

Project Information:

~~Local administration during the construction phase~~
granted as per the letter dated 7/22/99.
Academic siting study completed. Site selected is Welding Engineering site. The Welding Engineering Building has been demolished.

Project budget increased by \$400,000 to accept Alternate G-2 for Steam Line Tunnel Extension for Physical Facilities, by \$1.7 million to amend construction manager contract from partial to full service and by \$400,000 for acceptance of alternates by the user.

Source of Funds:	Original	Revised	Uses of Funds:	As Designed	As Bid	Completion
Development-Math & Physical Sci	\$0.00	\$401,221.00	Construction	\$40,355,390.00	\$40,325,547.00	\$0.00
Centrally Funded Capital	\$0.00	\$1,940,615.00	Construction Manager	\$2,702,200.00	\$2,702,200.00	\$0.00
Projects			Contingency	\$2,298,557.00	\$2,298,557.00	\$0.00
HB870 Columbus Line Item	\$0.00	\$0.00	Design	\$4,675,458.00	\$4,675,458.00	\$0.00
Future Capital	\$26,000,000.00	\$0.00	Equipment	\$1,960,000.00	\$1,960,000.00	\$0.00
Appropriations			Percent for Art	\$460,000.00	\$460,000.00	\$0.00
HB748 Columbus Line	\$4,000,000.00	\$4,000,000.00	State Architect	\$157,080.00	\$157,080.00	\$0.00
Items			University Administration	\$351,737.38	\$351,454.00	\$0.00
HB850 Line Item	\$20,000,000.00	\$20,000,000.00	Total:	\$52,960,422.38	\$52,930,296.00	\$0.00
Appropriation						
HB640 Line Item	\$0.00	\$26,000,000.00				
Appropriation						
HB640 Basic Renovations	\$0.00	\$200,000.00				
GENERAL FUNDS - PHYSICS	\$0.00	\$150,000.00				
Repair & Renovation	\$0.00	\$238,460.00				
Fiscal Yr 01-02						
Repair & Renovation	\$0.00	\$0.00				
Fiscal Yr 02-03						
Total:	\$50,000,000.00	\$52,930,296.00				



Physical Sciences Research Building
315-1999-195

Schedule:	Projected	Revised	Actual
Planning			
Arch/Engr Approved by B/T (\$49,000,000 Project)	11/01/1996		11/01/1996
Constr Mgr Approved by B/T (\$1,000,000 Contract)			11/02/2001
Bidding Approved B/T (\$50,000,000 Project)	11/01/1998	02/05/1999	02/05/1999
Design			
Arch/Engr Contract			05/15/1998
Schematic Design Approval	01/01/1998	06/01/2000	09/27/2000
Design Dev Document Approval	06/01/1998	03/15/2001	03/16/2001
Construction Document Approval	01/01/1999	03/08/2002	03/07/2002
Bidding			
Bid Opening	03/01/1999	04/16/2002	05/21/2002
Construction			
Award of Contracts			06/20/1998
Construction Start	06/01/1999	07/22/2002	08/09/2002
Report of Award to B/T (\$52,930,296 Project)	06/01/1999	02/07/2003	
Completion	06/01/2001	09/03/2004	
FF&E			
FF&E Final Quotes From Contracts	10/14/2003		
FF&E Purchasing	10/22/2003		
FF&E Funding Release	04/01/2004		
FF&E Coord/Order Tracking	06/17/2004		
FF&E Pre-installation Meeting	07/22/2004		
FF&E Installation	10/21/2004		

Physical Sciences Research Building

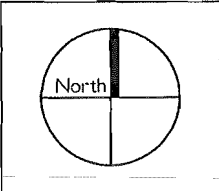
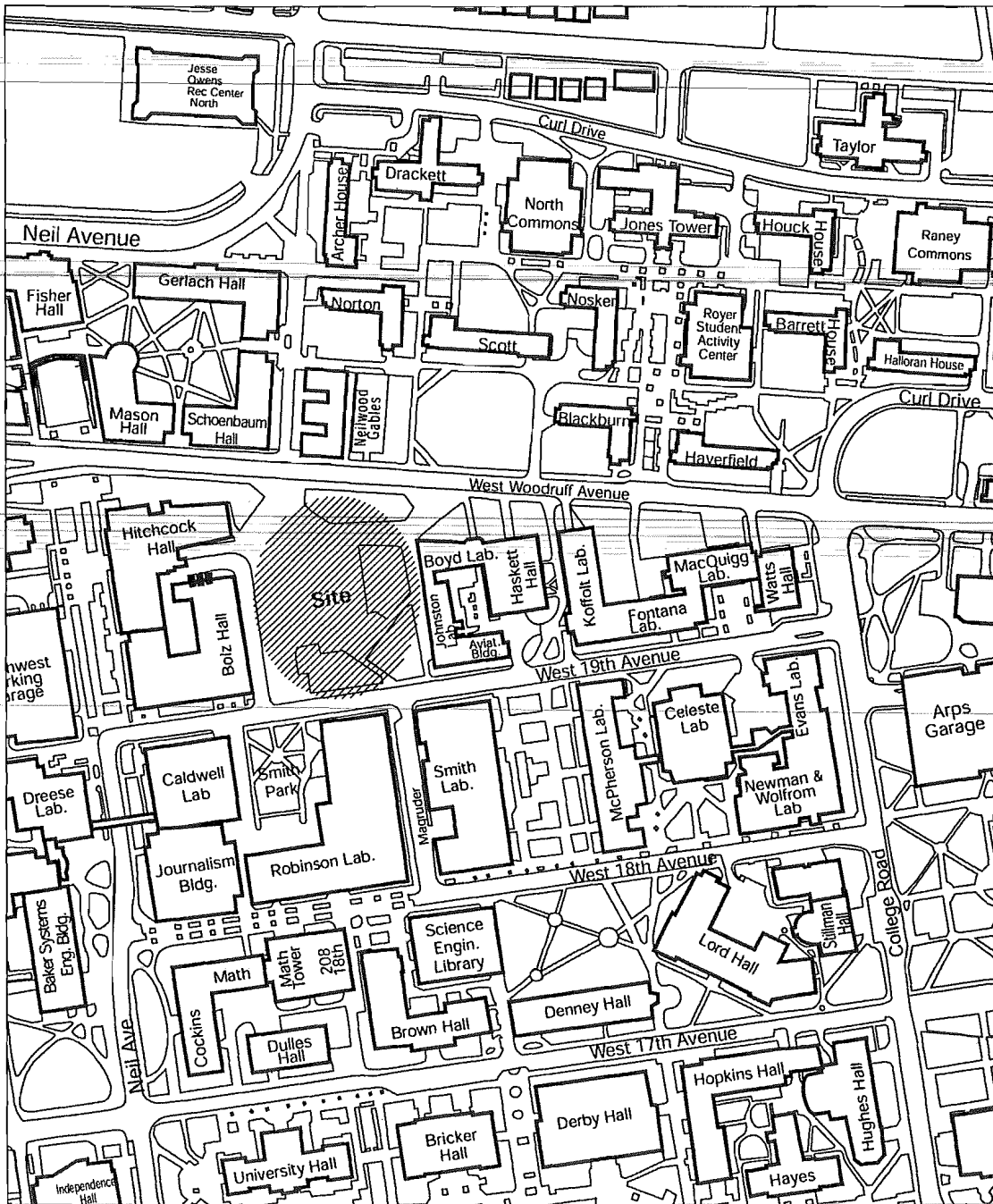

Office of Business and Finance
Office of Facilities Planning and Development

December 9, 2000



Postle Hall - Oral and Maxillofacial Surgery

315-2000-964

Requesting Agency(s): DENTISTRY ADMINISTRATION

Location(s): POSTLE HALL, WENDELL D.

Gross Sq. Ft.278,169 Age: 1950

Description: Renovation of area to reconfigure for provision of Oral and Maxillofacial Surgical Services as are currently provided -- climate control, walls, floors, ceilings, etc. All dental equipment and special items to be purchase outside the construction budget.

Project Team:

Facility Planner: Is Unassigned
 Project Captain: Sara Herridge (herridge.4@osu.edu)
 Project Assistant: Curt Handschug (handschug.1@osu.edu)
 Field Coordinator: Is Unassigned

Project Information:

Formerly project number 50700-R001638.
 The user revised the scope during the design phases of the project to provide a replacement Air Handler Unit to the area with all new ductwork and piping to the area, a new vacuum system to the area, and new built in metal casework in many of the rooms.
 Additional scope changes in the amount of \$16,000 requested by the user during construction.

Source of Funds:	Original	Revised	Uses of Funds:	As Designed	As Bid	Completion
General Funds-Dentistry	\$1,031,405.00	\$905,121.00	Construction	\$955,081.00	\$674,656.00	\$0.00
Total:	\$1,031,405.00	\$905,121.00	Contingency	\$95,508.10	\$91,115.66	\$0.00
			Design	\$112,907.00	\$112,907.00	\$0.00
			University Administration	\$14,326.22	\$10,442.34	\$0.00
			Total:	\$1,177,822.32	\$889,121.00	\$0.00

Schedule:	Projected	Revised	Actual
Planning			
Arch/Engr Approved by B/T (\$1,031,405 Project)	12/01/2000		12/01/2000
Bidding Approved B/T (\$1,031,405 Project)	12/01/2000		12/01/2000
Design			
Arch/Engr Contract	04/01/2001		05/08/2001
Schematic Design Approval	08/01/2001		08/13/2001
Design Dev Document Approval	10/01/2001	11/15/2001	08/13/2001
Construction Document Approval	11/03/2001	11/15/2001	12/03/2001
Bidding			
Bid Opening	01/01/2002		03/20/2002
Construction			
Award of Contracts	02/15/2002	05/14/2002	06/18/2002
Construction Start	02/15/2002	05/28/2002	06/24/2002
Report of Award to B/T (\$889,121 Project)	03/01/2002	02/07/2003	
Completion	10/15/2002	02/02/2003	

Postle Hall - Oral and Maxillofacial Surgery

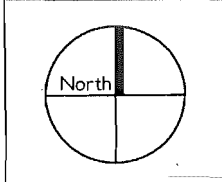
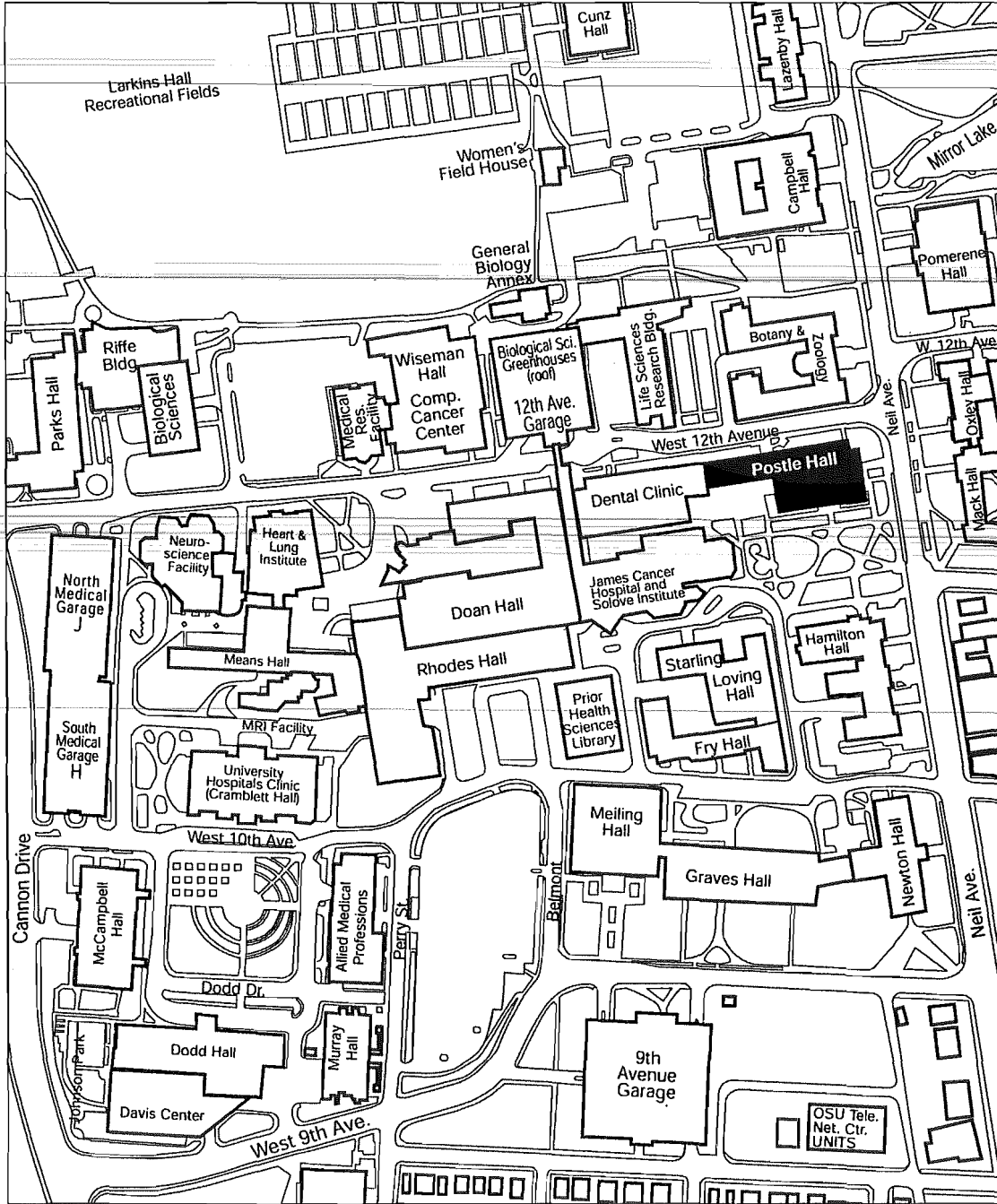

Office of Business and Finance
Office of Facilities Planning and Development

December 9, 2000



Requesting Agency(s): TREASURER

Location(s): RIVERWATCH TOWER (SUITE 100B,100C)

Gross Sq. Ft.10,294 Age: 1987

Description: Renovation of office space for the University Treasurer's staff located on the ground floor of Riverwatch Tower. Scope of work includes selective demolition, some new walls and doors, painting, carpeting, new ceilings and lighting, minor mechanical upgrades, data and electrical upgrades, office furniture, and ADA upgrades to the restrooms.

Project Team:

Facility Planner: Mehul Mody

Project Captain: Ruth Miller
(miller.2495@osu.edu)

Project Assistant: Lisa Baldwin
(baldwin.10@osu.edu)

Field Coordinator: Js Unassigned

Project Information:

The original project scope was to renovate the space occupied by the Treasurer's Office in Riverwatch Tower at as cost of approximately \$181,000. During the design process, occupants in the adjacent space (ACUHO) moved out and their space was assigned to the Treasurer's Office as well. It was determined that this additional space should also be included in the renovation as it would permit the Treasurer's Office to move additional staff from Lincoln Tower to Riverwatch Tower.

Source of Funds:	Original	Revised	Uses of Funds:	As Designed	As Bid	Completion
General Funds-Finance	\$326,612.00	\$375,656.00	Construction	\$314,938.00	\$254,200.00	\$0.00
Total:	\$326,612.00	\$375,656.00	Contingency	\$29,604.30	\$91,617.80	\$0.00
			Design	\$24,500.00	\$24,500.00	\$0.00
			University Administration	\$6,613.70	\$5,338.20	\$0.00
			Total:	\$375,656.00	\$375,656.00	\$0.00

Schedule:	Projected	Revised	Actual
Planning			
Arch/Engr Approved by B/T (\$326,612 Project)	02/01/2002		02/01/2002
Bidding Approved B/T (\$326,612 Project)	02/01/2002		02/01/2002
Design			
Arch/Engr Contract	01/10/2000	01/10/2000	01/15/2000
Schematic Design Approval	05/02/2000	06/15/2000	06/28/2000
Design Dev Document Approval	06/01/2000	08/15/2000	07/15/2000
Construction Document Approval		11/25/2001	11/25/2001
Bidding			
Bid Opening	04/15/2002	05/23/2002	05/23/2002
Construction			
Award of Contracts	05/30/2002	07/09/2002	07/22/2002
Construction Start	05/30/2002	07/15/2002	07/22/2002
Report of Award to B/T (\$375,656 Project)	02/07/2003		
Completion	11/30/2002	03/01/2003	

Riverwatch Tower - Suites B and C

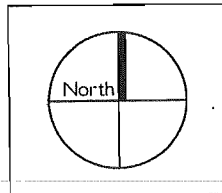
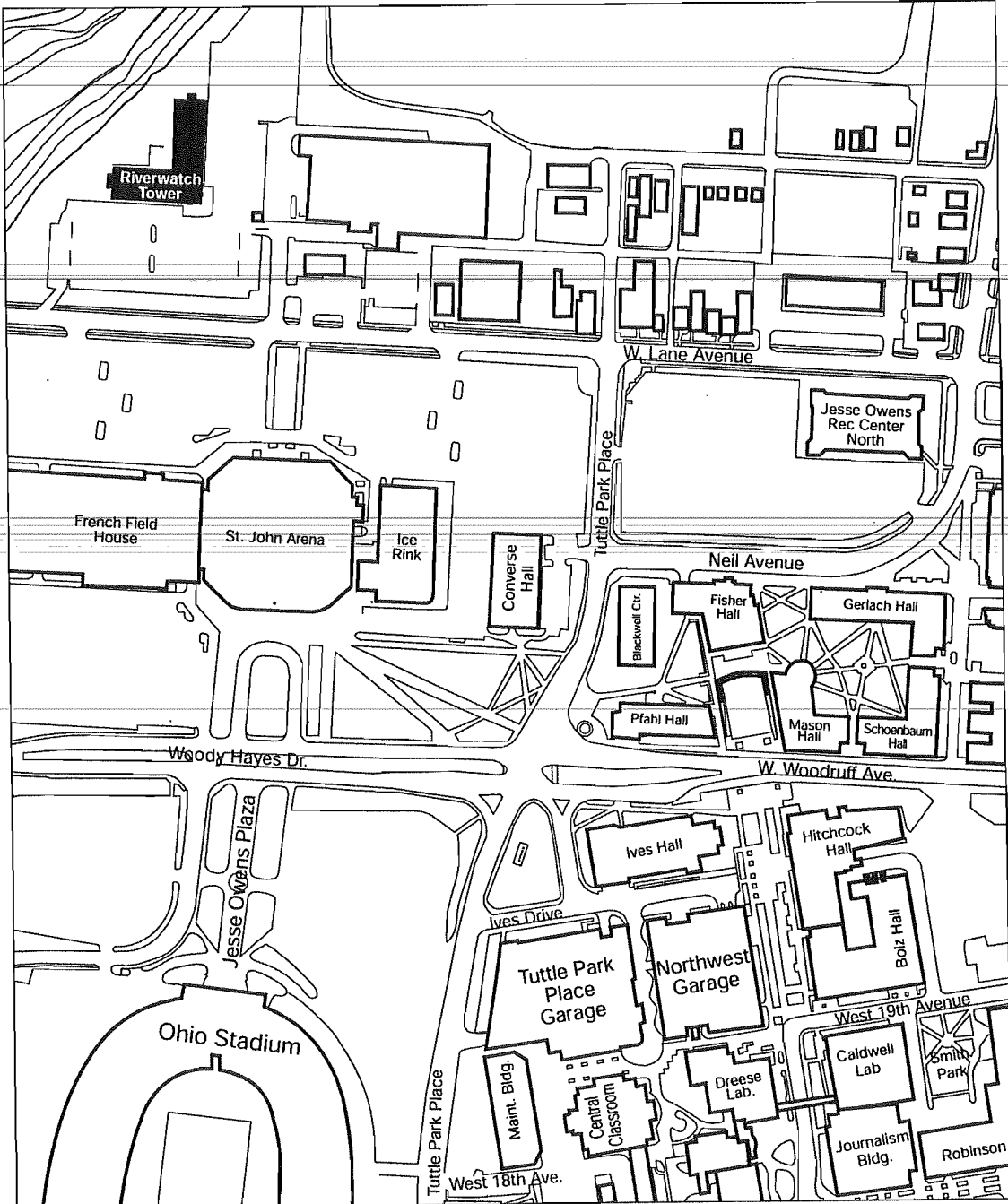

Office of Business and Finance
Office of Facilities Planning and Development

January 10, 2002



Requesting Agency(s): MEDICINE AND PUBLIC HEALTH ADMIN

Location(s): STARLING LOVING HALL

Gross Sq. Ft. 141,920 Age: 1917

Description: Renovate selected spaces in the basement M-Wing of Starling-Loving Hall.

Project Team:

Facility Planner: Teresa Yu
(yu.195@osu.edu)
Project Captain: Sara Herridge
(herridge.4@osu.edu)
Project Assistant: Curt Handschug
(handschug.1@osu.edu)
Field Coordinator: Is Unassigned

Project Information:

SFC granted the project additional funding for sprinkler requirement that went into effect in December of 2001 for Starling-Loving Hall Building
Budget and Funding reduced due to bids coming in below estimates. (1/6/03)

Source of Funds:	Original	Revised	Uses of Funds:	As Designed	As Bid	Completion
General Funds-Medicine	\$75,500.00	\$66,825.00	Construction	\$683,800.00	\$550,369.00	\$0.00
HB640 Basic Renovations	\$682,000.00	\$682,000.00	Contingency	\$68,380.00	\$82,555.23	\$0.00
Total:	\$757,500.00	\$748,825.00	Design	\$68,901.23	\$68,901.23	\$0.00
			Equipment	\$38,744.00	\$38,744.00	\$0.00
			University Administration	\$10,257.00	\$8,255.54	\$0.00
			Total:	\$870,082.23	\$748,825.00	\$0.00

Schedule:

	Projected	Revised	Actual
Planning			
Arch/Engr Approved by B/T (\$757,500 Project)	02/02/2001		02/02/2001
Bidding Approved B/T (\$757,500 Project)	02/02/2001		02/02/2001
Design			
Arch/Engr Contract	02/01/2001	11/01/2001	11/06/2001
Schematic Design Approval	05/01/2001	01/01/2002	02/22/2002
Design Dev Document Approval	08/01/2001	03/01/2002	02/22/2002
Construction Document Approval	11/01/2001	07/01/2002	05/20/2002
Bidding			
Bid Opening	01/02/2002	12/04/2002	12/04/2002
Construction			
Award of Contracts	02/14/2002	02/20/2003	
Construction Start	02/15/2002	03/01/2003	
Report of Award to B/T (\$748,825 Project)	12/01/2002	02/07/2003	
Completion	10/15/2002	11/17/2003	

Starling - Loving Hall Renovation

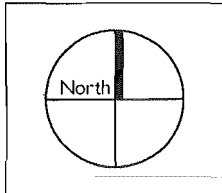
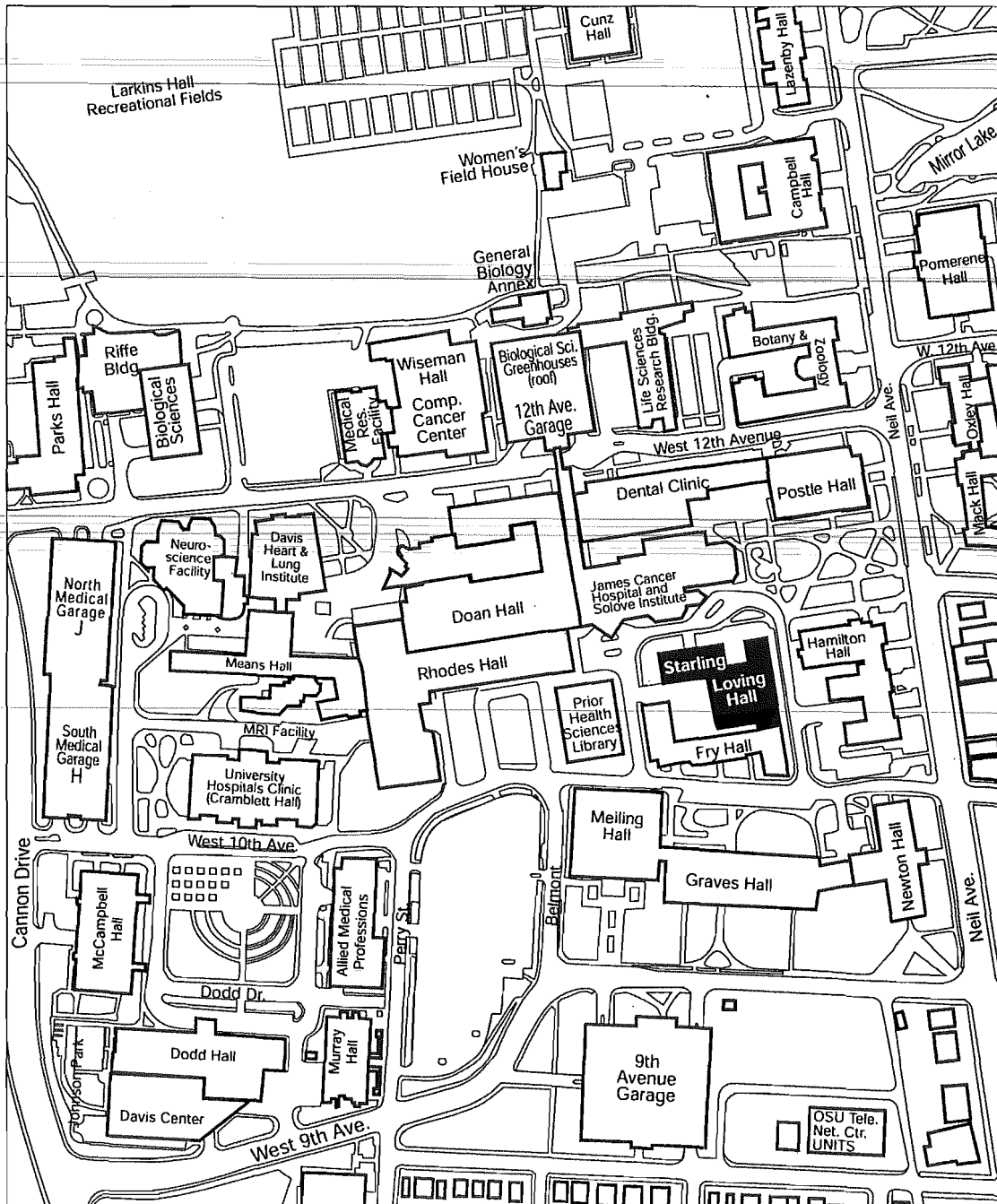

Office of Business and Finance
Office of Facilities Planning and Development

January 13, 2003



University Hospitals/Rhodes Hall Entrance

50700-R014354

Requesting Agency(s): UNIVERSITY HOSPITALS

Location(s): RHODES HALL-UNIVERSITY HOSPITAL

Gross Sq. Ft.510,587 Age: 1979

Description: University Hospitals requests architectural/engineering services for design and then the construction of the entrance/expansion of Rhodes Hall.

Project Team:

Facility Planner: Is Unassigned

Project Captain: Richard Van Deusen
(van-deusen.2@osu.edu)

Project Assistant: Andrea Thimmes
(thimmes.5@osu.edu)

Field Coordinator: Is Unassigned

Project Information:

Scope change of \$2,314 requested by the user during construction.

Source of Funds:	Original	Revised	Uses of Funds:	As Designed	As Bid	Completion
Auxiliaries-University Hospitals	\$270,000.00	\$294,795.76	Construction	\$223,500.00	\$242,496.00	\$0.00
			Contingency	\$22,350.00	\$24,249.60	\$0.00
			Design	\$20,644.00	\$20,644.00	\$0.00
Total:	\$270,000.00	\$294,795.76	University Administration	\$4,693.50	\$5,092.42	\$0.00
			Total:	\$271,187.50	\$292,482.02	\$0.00

Schedule:

	Projected	Revised	Actual
Planning			
Bidding Approved B/T (\$270,000 Project)	04/05/2002		04/05/2002
Design			
Design Dev Document Approval	10/17/2001		10/17/2001
Construction Document Approval	11/16/2001		11/16/2001
Bidding			
Bid Opening	04/15/2002	05/22/2002	05/30/2002
Construction			
Award of Contracts	07/10/2002	08/26/2002	08/26/2002
Construction Start	07/15/2002	09/03/2002	10/01/2002
Report of Award to B/T (\$292,482.02 Project)	12/06/2002	02/07/2003	
Completion	11/01/2002	01/13/2003	

University Hospital/Rhodes Hall Entrance

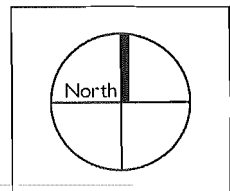
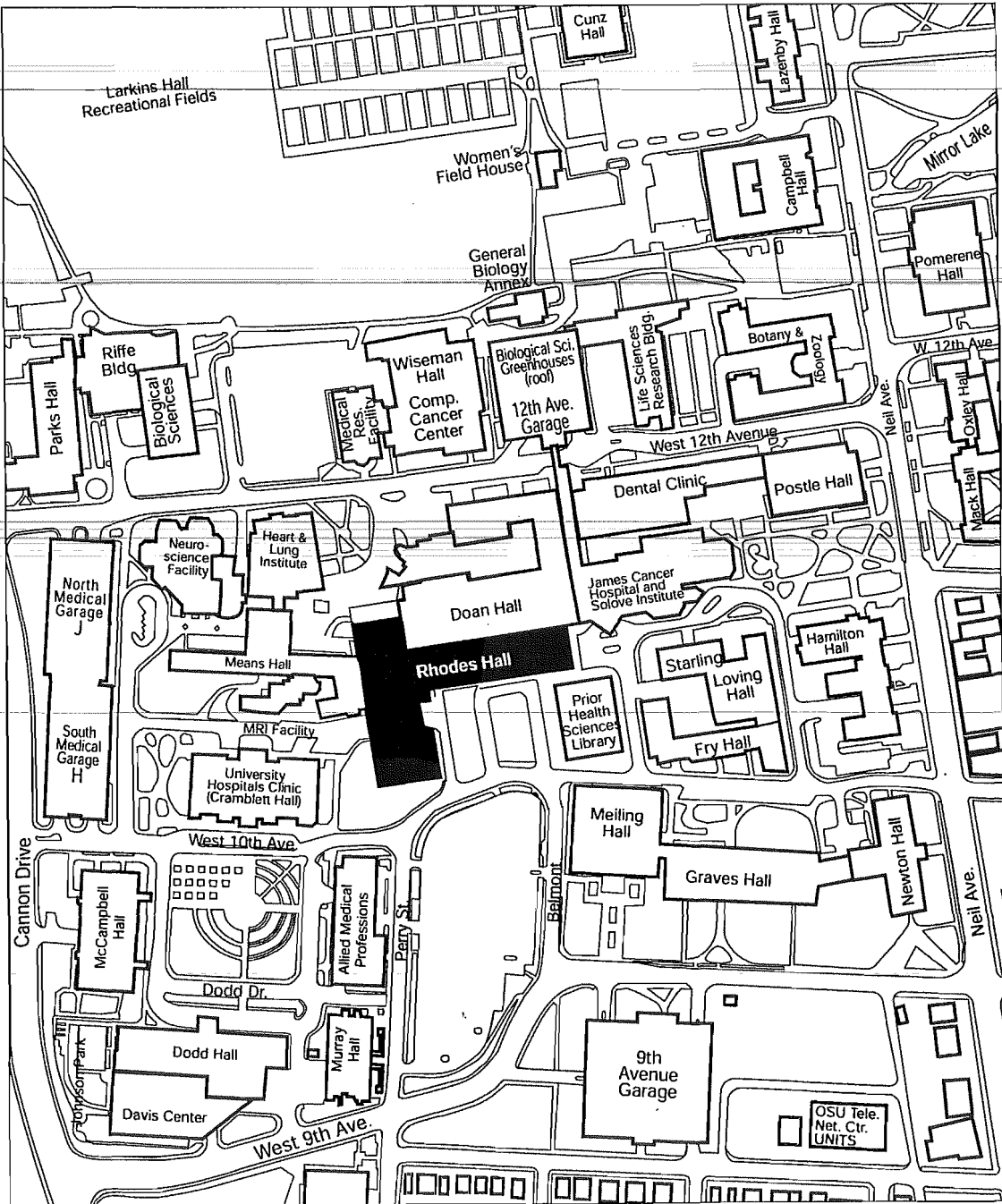

Office of Business and Finance
Office of Facilities Planning and Development

March 13, 2002



Wiseman Hall - Expand Comprehensive Cancer Center

315-1999-957

Requesting Agency(s): HEALTH SCIENCES ADMINISTRATION

Location(s): WISEMAN HALL, BRUCE K.

Gross Sq. Ft. 81,693 Age: 1960

Description: Design and construct a two-story addition of approximately 20,000 S.F. to the existing Comprehensive Cancer Center (10,000 S.F. per floor). The addition will extend the third and fourth floors out over the north side, second floor of Wiseman Hall.

Project Team:

Facility Planner: Teresa Yu
(yu.195@osu.edu)
Project Captain: Sara Herridge
(herridge.4@osu.edu)
Project Assistant: Mikki Reese
(reese.153@osu.edu)
Field Coordinator: Is Unassigned

Project Information:

Project budget of \$4,940,000 approved by the Board of Trustees on March 3, 2000. The project has expanded to approximately 42,000 S.F. The 3rd floor addition will be a shelled space and the 4th floor will be a finished space. An elevator is also added to serve all levels including the two new floors.
The budget further increased at the Construction Document Phase as a correction for inflation from 1998 dollars to current values. The estimate was in excess on funds available and additional funding was contributed by the user.

Source of Funds:	Original	Revised	Uses of Funds:	As Designed	As Bid	Completion
Development-Cancer	\$4,940,000.00	\$8,813,115.00	Construction	\$7,737,348.00	\$7,545,950.49	\$0.00
Hospital			Contingency	\$501,601.71	\$692,999.22	\$0.00
Repair & Renovation	\$35,000.00	\$35,000.00	Design	\$518,613.88	\$518,613.88	\$0.00
Fiscal Yr 02-03			University Administration	\$92,848.18	\$90,551.41	\$0.00
Total:	\$4,975,000.00	\$8,848,115.00	Total:	\$8,850,411.77	\$8,848,115.00	\$0.00

Schedule:

	Projected	Revised	Actual
Planning			
Arch/Engr Approved by B/T (\$4,940,000 Project)	02/04/2000	03/03/2000	03/03/2000
Bidding Approved B/T (\$4,940,000 Project)			03/03/2000
Bidding Approved B/T (\$7,339,702 Project)	02/04/2000	03/03/2000	07/12/2002
Design			
Arch/Engr Contract	04/24/2000	04/15/2001	07/06/2001
Schematic Design Approval	08/07/2000	10/15/2001	12/06/2001
Design Dev Document Approval	10/02/2000	06/01/2002	03/28/2002
Construction Document Approval	12/11/2000	09/30/2002	09/26/2002
Bidding			
Bid Opening	01/15/2001	11/06/2002	11/06/2002
Construction			
Award of Contracts	03/12/2001	01/28/2003	
Construction Start	03/13/2001	01/28/2003	
Report of Award to B/T (\$8,848,115 Project)	04/01/2001	02/07/2003	
Completion	02/04/2002	01/22/2004	

Wiseman Hall - Comprehensive Cancer Center

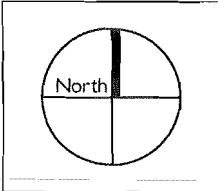
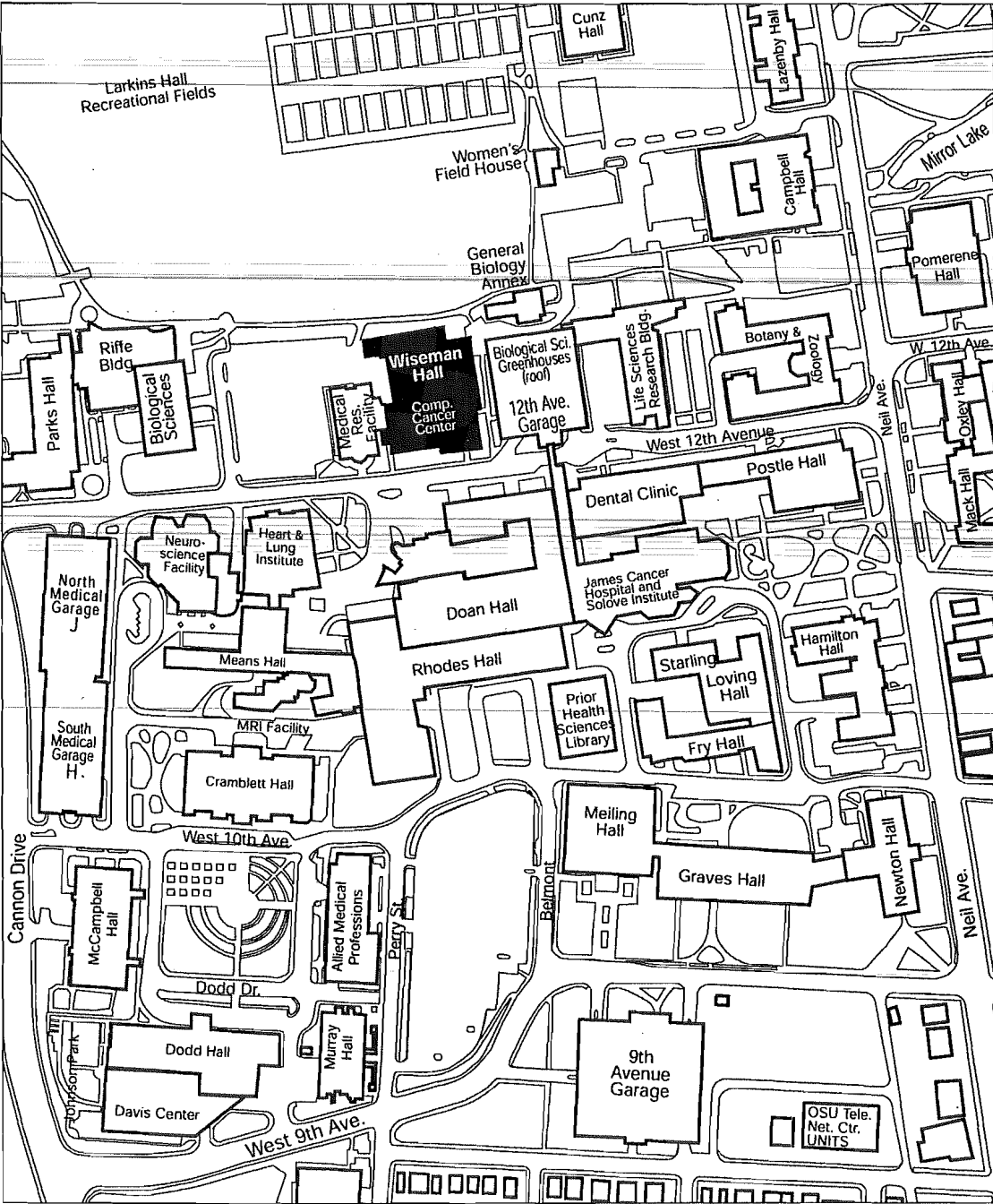

Office of Business and Finance
Office of Facilities Planning and Development

June 15, 2002



Women's Field House Relocation

9986-6746

Requesting Agency(s): PHYSICAL FACILITIES

Location(s): WOMEN'S FIELD HOUSE

Gross Sq. Ft. 5,353 Age: 1927

Description: Relocate the Women's Field House from behind Larkins Hall to east of Lincoln Tower with the existing grading conditions replicated and restoration of the exterior wood siding. Hazardous material abatement & utility cut-off prior to move. All utilities to be brought to new site for hook-up. The building will be used as an educational classroom building.

Project Team:

Project Information:

Facility Planner: Is Unassigned

Project Captain: Paul Sherwood
(Sherwood.1@osu.edu)

Project Assistant: Is Unassigned

Field Coordinator: Mark Hartmann
(hartmann.16@osu.edu)

Source of Funds:	Original	Revised	Uses of Funds:	As Designed	As Bid	Completion
Auxiliaries-Student Affairs	\$17,000.00	\$17,000.00				
Earnings-Business & Admin	\$354,935.00	\$354,935.00	Total:			
Repair & Renovation	\$300,000.00	\$300,000.00				
Fiscal Yr 01-02						
Total:	\$671,935.00	\$671,935.00				

Schedule:	Projected	Revised	Actual
Planning			
Bidding Approved B/T (\$671,935 Project)	09/13/2002		09/06/2002
Construction			
Construction Start	09/23/2002	07/19/2002	07/19/2002
Report of Award to B/T (\$671,935 Project)	10/04/2002	02/07/2003	
Completion	12/31/2002	01/11/2003	

Women's Field House Relocation

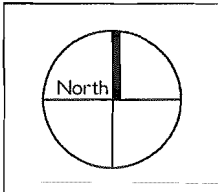
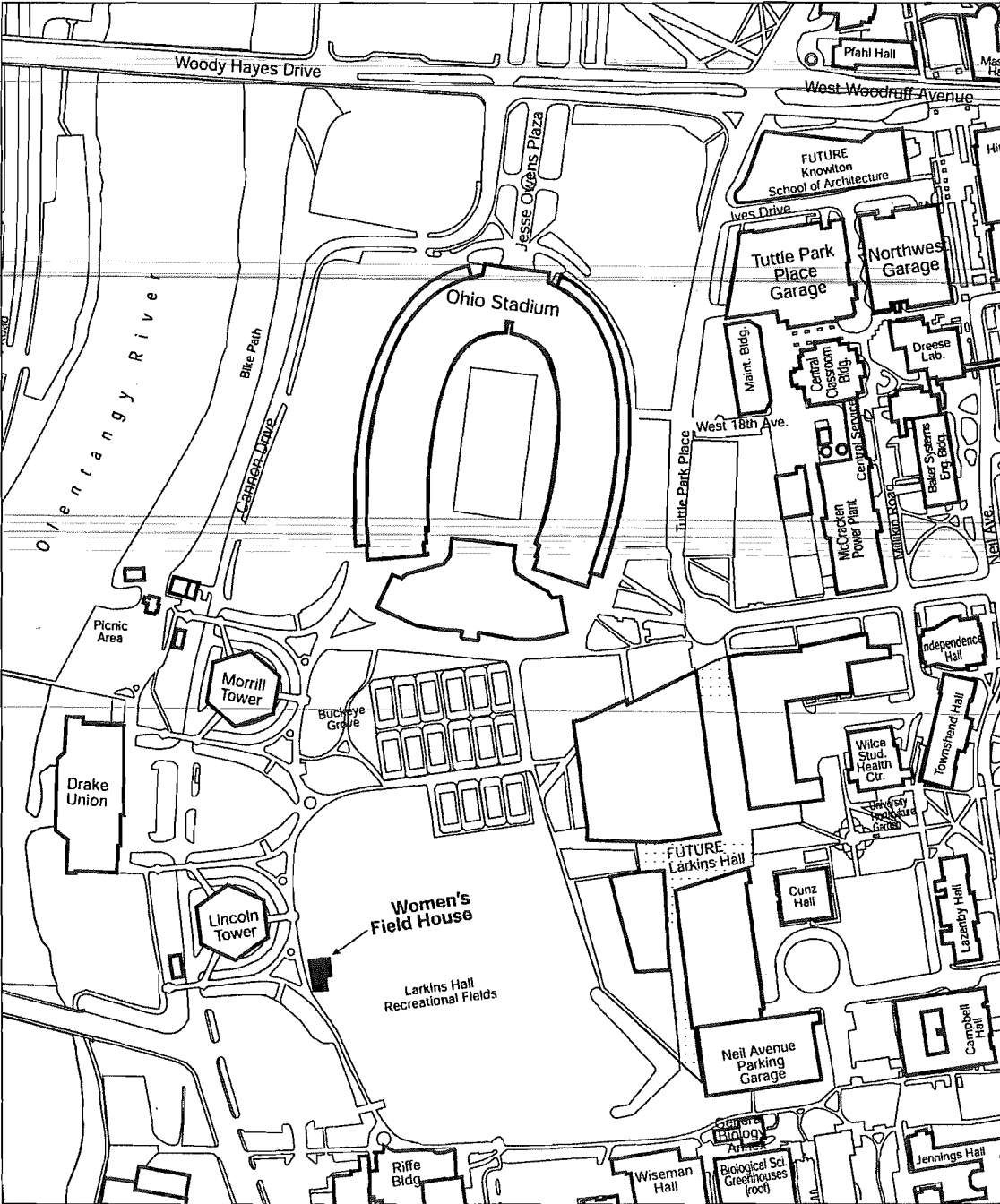

Office of Business and Finance
Office of Facilities Planning and Development

August 17, 2002

THE OHIO STATE UNIVERSITY
OFFICIAL PROCEEDINGS OF THE
ONE THOUSAND THREE HUNDRED AND NINETY-FIRST MEETING
OF THE BOARD OF TRUSTEES

Columbus, Ohio, March 5, 2003

The Board of Trustees met at its regular monthly meeting on Wednesday, March 5, 2003, at The Ohio State University Longaberger Alumni House, Columbus, Ohio, pursuant to adjournment.

**

**

**

Minutes of the last meeting were approved.

**

**

**

March 5, 2003 meeting, Board of Trustees

The Chairman, Mr. Patterson, called the meeting of the Board of Trustees to order on March 5, 2003, at 10:30 a.m. He requested the Secretary to call the roll.

Present: James F. Patterson, Chairman, Zuheir Sofia, Tami Longaberger, Robert M. Duncan, Karen L. Hendricks, Dimon R. McFerson, Jo Ann Davidson, Douglas G. Borrer, Joseph A. Shultz, and Paula A. Habib.

--0--

CHAIRMAN'S REPORT

Mr. Patterson:

I'd like to make the following comments about some of the things that the Board has been involved in and discussing. You may recall that in 1997, under the chairmanship of Les Wexner, The Ohio State University Board of Trustees took on a project with McKinsey & Company to look at the Board's overall governance structure.

The study was actually finished under the chairmanship of Alex Shumate and took a little over a year to complete. I know that there was a lot of depth and thought to it. The study itself was quite large and many areas were addressed including: the mission, vision, values, roles, Board structure, and Board agenda.

The lead principals were Jim Bennett and Bill Ross from McKinsey & Company. The intent was to periodically revisit the study, to take a look and see how it's done, to see if the changes that we made at that time were still apropos, whether major changes needed to be made, and whether some tweaking needed to be done here and there.

Since that time, we have not revisited it. About a year ago, as I was looking ahead to the upcoming chairmanship, I thought we really needed to revisit and take a look at that McKinsey study. It had been placed on the back burner. We had to find a new president and there were a lot of other issues taking up our time. So we came back to it this winter.

We believed that the time was right to take a look at the Board governance and to assure that we are being as effective as possible in performing our role as trustees. In that vein, we've begun to review means in which: 1) we can best devote our time and efforts to support the president and the administration; and 2) to ensure that our primary focus is on the strategic direction of the University. This, of course, has to be balanced with the legal responsibilities we have as a Board.

We are currently studying our committee structure. We've asked a small group of trustees to begin looking at that and to make a proposal to the Board that we might consider on a go-forward basis. With the combination of committees and representation that the trustees have on other boards or affiliated entities -- some 22 -- this is far too many for the Board to effectively participate in and to do our job well.

Over the course of the next few months, we will begin to implement some of these changes. Perhaps as early as next month in terms of some slight agenda modifications and committee structure. As someone said, "the only constant is change itself." This is a large, complex entity and we want to make sure that we as a Board are fulfilling our roles and responsibilities in the most effective way possible.

I think over the course of the next coming months, you will begin to see some slight changes in both our agenda and committee structures, how we address

CHAIRMAN'S REPORT (contd)

Mr. Patterson: (contd)

issues, and the Board making a determination on which strategic issues they should be involved in and which ones we shouldn't be involved in.

So I just wanted to report some of the ongoing discussion that the Board is having.

--0--

PRESIDENT'S REPORT

President Karen A. Holbrook: [PowerPoint Presentation]

Let me begin by making an announcement that I am very happy to make. I'd like to ask Ms. Ellyn Perrone to stand. Ellyn has just agreed to come to The Ohio State University as our new vice president for Government Relations. She will lead a very qualified and capable team of folks that we already have in place.

Ellyn comes from Texas A&M where she led a group of 16 people in the government affairs office and has been extremely effective at the federal level, at the state level, working with faculty, working with students, working with agencies, lobbyists, and organizations. Ellyn starts on April 1, and I am just delighted that she is here with us today. Ellyn, thank you for coming.

February for me was a month of a number of travels -- Board meetings with the American Association for the Advancement of Science, the American College on Education, meeting of the trustees of Embry Riddle Aeronautical University, an NCAA summit on sportsmanship and fan behavior, a visit to the White House to celebrate our wonderful National Championship team, and Ohio State's Winter College in Naples, with an opportunity to also meet with members of our alumni club in Sarasota and Manatee Counties. All of these meetings were very important, because they provided a sharper focus on some of the issues that every university across the nation is wrestling with today. They are issues that must be and are foremost on the minds of us at The Ohio State University.

First, I want to update you on one of the issues which we talked about last time and that's the Affirmative Action debate surrounding the University of Michigan cases. These will be argued in the Supreme Court beginning April 1.

Last month, I spoke to you about Ohio State's position. At the recent ACE meeting, President Mary Sue Coleman from Michigan spoke very eloquently about the Michigan case itself and reported that 300 organizations from academia, business, government, and from labor signed on to 64 amicus briefs. Chancellor Kirwan and President M. Lee Pelton, from the Willamette University, spoke very passionately in support of the Michigan case. Dr. Pelton is an African-American who received a Harvard education through Affirmative Action and has since reaped its many benefits.

The point of my presentation, though, is to mention that our students, our faculty, and our staff are not watching passively as this issue is being debated in court. Cullen Buie, whom you're going to recognize later, is one of our outstanding engineering students and he engaged Dr. Mac Stewart and Vice President Bill Hall in organizing a diversity forum that was held last week.

A panel that included Mabel Freeman, Martha Garland, Mac Stewart, Bill Hall, and me discussed the Michigan case and diversity at The Ohio State University.

PRESIDENT'S REPORT (contd)

President Holbrook: (contd)

For two hours, the standing-room-only crowd of students, faculty, and administrators filled the largest room in the Hale Cultural Center to listen to a few opening remarks, but more importantly to ask questions and to provide opinions in what resulted in a very valuable and important interchange. The students also described their plans to travel to Washington, D.C., on April 1 to take part in a rally that will show solidarity with the Michigan position.

The day after the forum I had the opportunity to meet with about 40 students from the Black Professional and Graduate Student Caucus who had similar questions and offered advice and suggestions for enhancing opportunity for minority students on our campus.

And, finally, The Ohio State University Council on Diversity passed a resolution that affirms, and I quote, "diversity is not a deficit, but a dividend, not a burden but a blessing, not a fad but our future." I thought that was a particularly poignant statement. I hadn't intended to repeat this topic as a major theme. But I think it is so significant and plays such an important role in how this University conducts its business, that I felt strongly about sharing these recent developments.

Let me now turn my attention to the major theme for today – the impact of the current national and international tensions on our University. I will discuss the effects on international students and scholars, our campus climate, the opportunities for dialogue and education that we are providing, and our plans to protect the safety and security of the campus.

Ohio State currently has 5,300 students and scholars who are here on H1B, F1, and J1 visas. A new federal law has created a database called the SEVIS system or the Student and Exchange Visitor Information System, which requires all colleges and universities to report in electronically to the INS on the enrollment, the status, the employment, and the major courses of study of all of our international students and scholars every quarter. We are in full compliance with this program, but it is nonetheless a challenge to keep up-to-date with all of these data.

Our Office of International Education is working closely with academic advisors to be certain that information is flowing in both directions – not just into the database but back to the students and scholars as well. So that we can assure that they remain in compliance also and that their positions are secure as continuing members of our campus community.

There are also a number of anecdotal, but also factual stories about the extreme difficulty some students -- especially those from China and from some of the Middle Eastern countries -- have had in obtaining visas since 9/11, and in returning to the United States when they've gone home for a period of time.

These are very serious barriers to our students and to the continuity of their academic programs, as well as for the many disciplines that rely on them to contribute to the work force, in science and engineering in particular, both in our country and worldwide. These barriers also represent great opportunity for Europe and Australia, in particular, to advance their position over the United States in delivering graduate education and in keeping graduate students once they complete their degrees.

President Bush has also directed that a second system called I-PASS -- or the Interagency Panel on Advanced Science and Security -- be implemented in the future. It would review the portfolios of individuals who work in certain fields of

PRESIDENT'S REPORT (contd)

President Holbrook: (contd)

science and technology, such as nuclear engineering -- fields that might be considered threatening to our country. These reviews will be carried out by individuals in the State Department who will determine whether or not a visa is issued. I-PASS will surely further impede the exchange of students and scholars to this University and to all universities in our country.

While our international students are experiencing obstacles in their studies, other parts of our campus are being affected in other ways. For example, our Study Abroad Programs, which we are closely monitoring, remain largely open but we have closed those where the State Department has issued warnings. At present, we've closed down programs in Israel, Jordan, and Syria. We've also recommended to our students who want to travel abroad that they not go to any of these countries where the State Department has issued warnings, although they may do so at their own risk.

We are also providing and will continue to provide travel advisories for this spring break as the world situation changes on a regular basis and may very well have changed by then. We're also evaluating Graduate School policies that relate to our international students who have been dismissed from a program and spend time trying to find other programs or even continuing education programs to stay in this country. And we're recommending that departments and colleges which attract a large number of international students begin to set earlier deadlines to admit and enroll students who will potentially face long delays when applying for visas.

In spite of all of these stringent restrictions and heightened security in this country, there is continued and even enhanced interest in international exchange of students and scholars at The Ohio State University – and this is a trend nationally as well.

We're also concerned about the campus climate and the comfort level of our international students who are here. Here are some of the steps we've taken to ensure a positive environment:

- There are many international student organizations on campus that provide support and an informal network of contacts for our students. These groups are working together right now to develop a resource guide and a listserver.
- The Office of International Education advises international students and scholars and meets monthly with the student clubs and encourages them to connect with other campus offices such as counseling and consultation services, advisors, and residence hall staff. This office is also able to monitor the campus climate through its regular communication with our students and scholars, and it maintains a web site with important information for them. In addition, our international students and scholars are very well connected with the Columbus community who has members that are from the countries of their origin.
- The Diversity Council and the Senate Diversity Committee are also focusing their attention on the well being of our international students and scholars.

We continue to ask everyone to take extra measures to respect, support, and value each other as individuals. At this point there is no evidence of intimidation, but we monitor that situation closely to assure that this remains the case.

PRESIDENT'S REPORT (contd)

President Holbrook: (contd)

We've also paid attention as to how we support our students, faculty, and staff who are called into active duty with the military so that there is a smooth transition for them out of the University and back into their roles on campus. We've established policies and guidelines, and all of these are available on the web site.

Let me move to the next topic. As the nation awaits a final decision on the invasion of Iraq and the color level corresponding to the threat of terrorism in our country is communicated, campuses must continue to provide a venue for open discussion and dialogue while we work to protect the safety and security of our people and environment.

The opportunity to learn, to question, and to debate our national position on Iraq is very important. We've provided and will continue to provide many opportunities for dialogue and education. I have listed just a few of the many upcoming and past events. In addition to those listed, we offer courses on aggression and violence and on the war in the Middle East. Dr. Rick Herrmann, director of the Mershon Center, has been meeting with small groups of students in residence halls to talk directly with them about the possibility of war with Iraq. Our radio station, WOSU, is broadcasting a series of programs through its PBS affiliation. The programs are called "By the People," and provides opportunities for our people in Central Ohio to debate and discuss Americans' role in the world.

Finally, I want to address the plans to protect the safety and security of our campus community. While it is unlikely that our city or campus would be a site for a terrorist attack, the FBI has suggested that campuses are at risk as "soft targets." It is therefore essential that we are as prepared as we can be. Moreover, everyone connected with this campus, directly or through friends or family members, needs to have confidence in our preparedness.

Here are some of the actions we've taken:

- We have increased campus security since 9/11, including our athletic venues.
- We have a revised emergency procedures booklet that is being distributed now and key contact individuals have been designated.
- We have established a web site where members of the University community, including parents, can access emergency information, and we have an 800 number that would be activated in an emergency.
- A crisis intervention team has been established and is prepared to handle various different emergency situations.
- Plans for evacuation are available right now in 75 percent of our buildings and are in progress for the remainder.
- We have an evacuation plan for the entire campus that is under review by Public Safety.
- A communications plan within the campus is available, and connects externally, and is being upgraded at present.
- An extensive system of plans is in place and in development at University Hospitals to assure care for those hospitalized, to activate

PRESIDENT'S REPORT (contd)

President Holbrook: (contd)

the engagement of first-line providers, and to make technology and facilities available for decontamination and treatment of those who might need care.

- Training exercises are held frequently, hospital capacity is reviewed on a regular basis and reported to the White House as required, and medical supplies are stockpiled.

We will also be working with Battelle in areas where their technology and expertise are at the forefront and we're connecting with the city as we make our plans. As well prepared as we are, University Public Safety continues to update a "to do" list to assure that we are as prepared as possible.

In the same vein, we can also provide assurance that we are managing so-called "select agents" – those organisms and toxins that would be the basis for a terrorist attack. We are in compliance with the federal guidelines for management, storage, and security, and are meeting all of the benchmark dates and policies.

Cyber security is also an issue as we depend on our technology to manage all aspects of our operations. Ohio State's fiber optic network is integrated so that the loss of function to one building would not interrupt operations to the remainder of the campus.

We are working to attain a high level of security in our technology by continually monitoring the integrity of the network. We are also engaging with security groups on campus and with national organizations that deal with these issues, and are participating in educational and training programs within the CIC. Software for viruses is constantly being updated.

OSU has a plan for business resumption to allow our fiscal and HR data to come back online in two hours if interrupted. Our student information system is backed up in coordination with the University of Cincinnati. Staff drills are held regularly, but we still need more preparation in administrative and academic departments in the area of technology.

And, finally, we do realize the need to communicate our level of preparedness, so I will be releasing a letter to the campus community about this topic this week.

I have confidence that The Ohio State University has devoted great effort to the preparation and safety of our people and operations. While I hope we never have to call on any of these emergency systems, I believe we can assure everyone that the University is thinking proactively how to manage emergencies – not in just *this* emergency or this potential national environment of concern, but on everyday matters that can interrupt our institution as well.

Mr. Patterson:

Thank you. As all of you know, this is an extremely important issue at this particular time. When you deal with it at a university like this, you have so many different concerns – the research that's being done, the technology that's involved, students, faculty, staff – you can imagine the complexity of it. There is reassurance that the University is looking at it and is on top of it.

--0--

SELECTIVE INVESTMENTS – HISTORY, PHYSICS, AND LAW

Provost Edward J. Ray: [PowerPoint Presentation]

This institution has no initiative that better exemplifies our commitment to academic excellence and our ability to make hard choices than the Selective Investment Awards program. The initiative was begun in 1997 to identify some of our strongest departments and programs and to give them the resources they need to move to the very top of their fields. The program represents a shared financial commitment. One million dollars in continuing funding is dedicated to implementing the plan of each of the 13 recipient programs, with half of the money provided from central funds and half from matching funds generated by internal reallocations of funds from the sponsoring colleges and departments. This investment in just 13 programs is equivalent to the payout of a \$260 million endowment in excellence.

All 13 of the Selective Investment programs were chosen based on their importance to our academic mission; their existing high level of excellence; their ability to promote inter-program collaborations and interdisciplinary activities; their ability to enhance excellence in related programs throughout the University; and their contributions to the University's outreach goals with business, industry, and the community. Results of our investment are already being realized. We are attracting outstanding scholars and students to these and related programs, and we are moving closer to our goal of making The Ohio State University one of the world's truly great universities.

Today, we will hear from deans, chairs, and faculty in History, Physics, and Law, who will discuss the uses of their Selective Investment funds and the impact that those investments are having on their programs. With us today are Dean Nancy Rogers from the Moritz College of Law; Professor Ken Andrien, chair of the Department of History; and Professors Chris Hammel and Bob Scherrer, two distinguished colleagues from the Department of Physics, who are here on behalf of Will Saam. Let me call on Professor Andrien to begin the presentation. Ken --

Professor Kenneth J. Andrien:

Dr. Ray, Dr. Holbrook, distinguished members of the Board, and distinguished attendees, I want to thank you for this opportunity to come and share some of our accomplishments in our Selective Investment Award. I was at one of your Board meetings last fall to talk about a grant which we'd received in partnership with the Columbus Public Schools and the Ohio Historical Society, and I want to thank you for this opportunity as well.

I have given each of you a packet of information, which simply lists a one-page summary of the curriculum vitae of the people that we've hired with our Selective Investment Award. I didn't want to highlight that, in particular, because what I really want to talk to you about today is the programmatic impact of Selective Investment and, secondly, the way that it's advanced our academic reputation.

Essentially, our goal in making our Selective Investment application was disarmingly simple: if you invest in good people, you will have good programming and you will advance your academic reputation. That is why we chose to hire six senior faculty members who can have an immediate impact on the programming on both the undergraduate and graduate levels and who can also have an impact on our national reputation.

Our goal was to become one of the top ten history departments in the United States. We were optimistic entering into Selective Investment, because we thought we had an excellent department already, as one of my anecdotes will tell

SELECTIVE INVESTMENTS – HISTORY, PHYSICS, AND LAW (contd)

Professor Andrien: (contd)

you. One of my colleagues who teaches at Columbia was talking to one of the editors of Cambridge University Press -- one of the premier presses in our field -- and he asked him, "You're publishing so many Ohio State history books, why don't you change the name of your press to The Ohio State University Press?" And Frank -- being a plain spoken man from Kansas -- said, "If I got better books from Harvard, I'd publish those!"

As I mentioned, our goals are clear. We're trying to move the Department forward and have a direct impact on programming. I'd like to talk a little bit about our strategy for how to accomplish this and give you an update on our progress, and then talk about Selective Investment and the Academic Plan as we understand it.

Essentially, our strategy to accomplish our goals was to build on areas of strength, to focus on two areas in particular: U.S. history and European history, which are the core of any great history department. Then to identify other areas of opportunity where we could have an impact, in this case Latin American history and Chinese history.

The positions in European history and U.S. history are central to the mission of any department. Latin American and China were chosen because of their popularity as undergraduate areas of strength in the Department and, secondly because, in the graduate education, we felt we could make an immediate impact there as well. Both Latin American history and Chinese history are areas where we're actually under-producing Ph.D.s, given the number of jobs that are available, so we weren't going to have a lot of unemployed graduates coming out in those fields. For example, one of my students this year finished his Ph.D. degree and had multiple job interviews and multiple job offers and ultimately selected a position at Northwestern.

Our progress to date is that we've hired six people and we have one position left to fill. What we chose to do was to hire four distinguished scholars in the main fields that I've already talked about. In modern U.S. history, we found that some of the most interesting work was being done by senior associate professors, and so we hired two people in modern U.S. history who were at that rank. It had a sort of interesting impact on the demographics of the department because, by and large, our Selective Investment hires, despite their distinction, are a bit younger than some of our other chairholders. Certainly by hiring two younger faculty in their early- to mid-40s, you can see that we'll have the impact of Selective Investment over the next 20-25 years. In other words, we'll be enjoying the fruits of these hires for quite a long time. It's not as though everyone will retire at once.

We made it clear when people came for their interviews for Selective Investment that these were positions of leadership -- they weren't sinecures. This wasn't a time to come and write your books and simply ignore the rest of the University. And, by and large, that's exactly what we've gotten from our Selective Investment hires. They're intellectual leaders within the department, but they are also excellent leaders in departmental governance. For example, one of our first Selective Investment hires, John Brook, in early U.S. history, is the chair of our promotion and tenure committee where he has a great deal of influence on shaping the future of our department.

These are also areas where we have an impact in undergraduate teaching. All of our faculty at the senior level teach undergraduate courses and, indeed, just

SELECTIVE INVESTMENTS – HISTORY, PHYSICS, AND LAW (contd)

Professor Andrien: (contd)

about everyone teaches large survey level classes. So from their freshman year onward, people get the opportunity to work with the faculty members that we hired with our Selective Investment Award. Several faculty members have been instrumental in pioneering new courses for undergraduates. John Brook developed a course in environmental history that we think will draw very well. And, indeed, our other Selective Investment hires have done similar things.

The most immediate impact that we see also is the impact on our graduate enrollments and graduate program. We see a marked increase in the areas where we have made Selective Investment hires. That is, we've actually seen the numbers of applications increase dramatically. For example, in early U.S. history when I started as graduate studies chair -- before I occupied this position just three years ago -- we had maybe a dozen applicants in that field. Now we have a whole box filled with applicants in that field.

Now we've done this in a variety of ways. We've tried to advertise our Selective Investment program through our newsletter, by taking out an advertisement in the American Historical Association's publication *Perspectives*, by our brochures about Selective Investment areas, and highlighting this on our web page. The word is out that Ohio State's History Department has engaged in Selective Investment and that we have been very successful in hiring distinguished people. In fact, I was asked more questions at the American Historical Association meeting in January about our new hires than I did about our football team. This probably says something about how sports literate historians are, but nonetheless, it does say that we've made an impact in the field.

The other thing that has happened in our department is that, in a very real sense, Selective Investment has helped to raise the bar a few notches in terms of scholarship and citizenship. It makes people aware in the department that the accomplishments and the expectations are very high and rising, not static.

I'd also like to talk just a bit about how we see Selective Investment advancing the Academic Plan -- a wonderful document. Just to mention a couple of major points, one of the points highlighted in the Academic Plan is to build a world-class faculty and clearly Selective Investment advances that goal. In History, it's also to enrich undergraduate learning and, of course, our faculty do that directly through teaching. To develop programs that define Ohio State as a leading public land-grant university. In all ways, Selective Investment helps with that goal as well. By advancing the Academic Plan, Selective Investment helps to advance programming, instruction, and research in the History Department and, in doing so, advances our national and international standing.

We all know that we're facing some difficult times ahead. Two things we try and keep before us in the History Department are to maintain and retain our faculty and our faculty resources. If we can do that, and maintain our standards at a high level -- which we've done over the years through budget cuts much worse than what we're looking at now -- we feel that Selective Investment will continue to enrich the department and advance our reputation. If you keep your people and you keep your standards, then you can move forward through any difficult times. Thank you.

Provost Ray:

Thank you, Ken.

SELECTIVE INVESTMENTS – HISTORY, PHYSICS, AND LAW (contd)

Mr. McFerson:

How many students and faculty are in the Department of History?

Professor Andrien:

There are 56 faculty in history and each year we teach somewhere between 14,000 and 16,000 students at the undergraduate and graduate levels.

Provost Ray:

Are there any other questions before we move on?

Mr. Borrer:

I would like to say that as a graduate with a history major, I think you're doing a great job. I had the opportunity to visit with a number of people in the History Department just last week and I'm very proud of what you're doing. You're doing a wonderful job; keep up the good work.

Professor Andrien:

Thank you very much.

Provost Ray:

Let me now call on Professor Hammel and Professor Scherrer, from the Department of Physics, to talk about the Selective Investment program there.

Professor Robert J. Scherrer: [PowerPoint Presentation]

I'm Bob Scherrer, acting chair in the Physics Department – Will Saam is, in fact, sick today. With me today is Chris Hammel, our newest Eminent Scholar, who joined the department last summer. What I'd like to do is give you an overview of our major activities in the Physics Department and then discuss specifically what we've done with the Selective Investment.

Our department consists of about 50 faculty and we have 190 undergraduate majors. Our undergraduate program is actually growing at a time when most undergraduate physics programs in the country are shrinking. The department is ranked in the top 25 nationally by the National Research Council. It includes two Eminent Scholars, one of who is Chris Hammel, three Distinguished University Professors, and ten OSU Distinguished Scholars. Here is a photo of Frank De Lucia, one of our Distinguished University Professors, demonstrating conservation and momentum in action. Frank was also chairperson of the department for eight years.

Our grant expenditures from OSURF in the last year put us third in the University. Of course, we are a Selective Investment department and we also have a record of quality teaching. We are the winner of the Distinguished Departmental Teaching Award and we've had five Distinguished Teaching Award winners in the past seven years, including one this year -- a faculty member who was, in fact, hired under the Selective Investment program.

We also have an innovative program of undergraduate scholarships. This is an example of using departmental money to seed outside money. We supported these initially purely with departmental funds to pay for undergraduate physics

SELECTIVE INVESTMENTS – HISTORY, PHYSICS, AND LAW (contd)

Professor Scherrer: (contd)

majors to attend the University. Ed Grilly -- pictured here with two of the scholarship winners -- funded two of these scholarships.

We have an undergraduate physics lounge in our current building, which is a nice way of bringing undergraduates together to work on problem sets -- it gives them a family feeling in the department. We've done very well in our undergraduate NSF fellowship winners. We have ranked 5th nationally over the last three years, ahead of schools like Columbia, Cornell, the University of Chicago, Yale, and the University of Michigan. Here is a picture of last year's winner, Carolyn Gilbert. Carolyn was a 2001 Goldwater Scholar and a 2002 NSF Fellow. She is now in the graduate program in astronomy at the University of California.

We do a lot of recruiting and outreach. This photo shows former President Kirwan on a stationary bicycle. He attended the open houses we hold every fall. At these open houses we bring in high school students from around Ohio, who are interested in physics to show them what we do here and invite them to become a part of the Physics Department.

Here are some more photos on recruiting and outreach. This photo is of Linn Van Woerkom's lab. Most physics labs do not look like they do in the movies. Physics labs always have a lot of aluminum foil, they look like someone's baking a turkey, and have cables everywhere. Linn is explaining to these high school students what he does in his lab, which he explains to me regularly, too. After taking students down there about once a month, I still am not completely sure what he's doing.

We're central to the mission of the University. One in three OSU graduate students takes a physics course while they are here at the University. Our major areas of research are some of the most exciting areas in physics, and the Selective Investment has allowed us to move into some new areas that I'll talk about. I particularly want to highlight the Physics Education Group. That's a very innovative group, which is taking a scientific approach to learning how people learn about physics and trying to improve the way that we approach our teaching.

We have many interdisciplinary connections. The biophysics connection was, in fact, started with Selective Investment funds. We have collaborations with many departments around campus and even collaborate with the Art Department in a holography class. In fact, I have a joint appointment in Astronomy.

We have a new building that is under construction. The work is proceeding at a furious pace and groundbreaking was last year. The new building will be a major recruiting tool, especially for our experimental colleagues, because it will have up-to-date lab space. I think it was a major recruiting tool in bringing Chris Hammel to Ohio State.

Where have we gone with Selective Investment? We made a decision to go into several specific areas of physics -- string theory, hot dense nuclear matter, and biophysics -- and actually used some of the money to seed an endowed chair. This is another example of investing our money and bringing in more outside money. The Hagenlockers donated money to the department to establish an endowed chair in atomic molecular and optical physics and some of that money that we used for the chair came from Selective Investment. Of course, we're sponsoring graduate fellowships that benefit our students in all areas of physics.

SELECTIVE INVESTMENTS – HISTORY, PHYSICS, AND LAW (contd)

Professor Scherrer: (contd)

What is string theory? String theory is the forefront field of physics right now -- an attempt to unify gravity and quantum mechanics. This is something that Albert Einstein couldn't do, but we're going to do it now. He didn't know about string theory. So it is, in fact, the most complex, hard-to-understand forefront area of physics. I want to point out that we've hired two faculty in that area and one of them, Simier Mathor, was one of the winners of this year's Alumni Teaching Award. So it shows that if you can explain string theory, you can pretty much explain anything.

We've also hired one senior faculty member in the area of hot and dense nuclear matter. This is the study of the quark gluon plasma, which was basically the state of the universe in its first few microseconds. They're working on recreating this at the Brookhaven National Laboratory on Long Island. Trying to explain and understand what happens when you compress matter to such high densities that you recreate the conditions of the early universe.

I'm going to turn the talk over to Chris Hammel for a few minutes, and he's going to talk about some of the things he works on that are related to our Selective Investment thrust.

Professor P. Christopher Hammel:

Good morning. My name is Chris Hammel and I am an experimentalist in condensed matter physics. I'm a new member of the Department and am very proud and excited to be here. What I'm going to try and do is give you a brief snapshot of what we're doing. I would like to make one point before I do that, and that is to emphasize another strength of Selective Investment.

In my case, I had many choices when I was making the decision about where I was going to move. I was looking at similarly highly ranked departments, in fact, there were some in places having significantly less challenging winter weather. One of the key reasons that I chose to come to Ohio State is that it was very clear that the University was investing in the department and it was a place that was going to be growing. That was really the factor that made up my mind.

So let me tell you a little bit about what I'm trying to do here. I think many of you are aware of magnetic resonance imaging. It is a very powerful biomedical tool. Its power comes from the fact that you can get images deep inside the person you're trying to look at and it is completely non-invasive. There is nothing that has to be inserted in order to get this information. What I'm hoping to do is -- by using techniques taken from technology called atomic force microscopy -- push the resolution of magnetic resonance imaging down to the atomic scale. That would be a very exciting thing if we could do that.

Let me show you some of the things that we hope we can do. This is an image of the microscope that I had in my previous lab and I'm building similar microscopes, better ones at present. This is just a little device that scans around a tip that, as you can see, is less than a micron in diameter. We scan that over the sample and we do magnetic resonance. This is a tool that will enable us to enter into a number of very important areas, including nanotechnology, spintronics -- which is the area of using electronic spin as part of an electronic device -- and, I think, it will be a very powerful tool in biological and biomedical research applications.

SELECTIVE INVESTMENTS – HISTORY, PHYSICS, AND LAW (contd)

Professor Hammel: (contd)

Magnetic resonance has been powerfully applied to cell biology for many years and is very useful because you don't have to kill the cells. For the same reason I was saying before, you can look at cells as they evolve. What we hope to be able to do is to look at individual cells and expand the power, rather than having to look at large collections.

One of the most exciting areas of spintronics is the area of quantum computing. The idea here is you know that your computer runs on ones and zeros. What we want to do is use individual atoms for those ones and zeros – really shrink things down. We're going to use silicon, which is a well-known and powerful technology, and this is going to bring much more powerful technology for computing to us. This, of course, will be very important in nanotechnology as we move forward.

Professor Scherrer:

To summarize, Selective Investment really has helped us in a number of areas. We've been able to branch out into some new research areas, such as string theory, biophysics, and ultrahigh dense nuclear matter, which we would not have been able to do otherwise. These are some of the major areas of physics that our department had not been previously working in.

A corollary of that has been recruiting major new faculty in all of these areas. We've developed interdisciplinary collaborations, especially in the biophysics areas, but in a number of other areas, and we've been able to use some of this money as seed money to attract outside funding. So, Selective Investment has been extremely helpful in our mission and we hope it will help us as we move forward. Thank you.

Provost Ray:

Are there any questions or comments before we move on? As Professor Scherrer indicated, we always talk about the tyranny of the "or." We talk about teaching, research, and scholarship. It is worth noting that any time we have both the Departments of History and Physics receiving both the Selective Investment Award, through a very rigorous competitive process, and the Departmental Teaching Award, we want to replicate this throughout the University. When we talk about a truly great University, it's not about bragging rights, it's about the quality of everything that you do, from the classroom to the laboratory, and these are two exemplary programs in that sense.

It is now my great pleasure to call on Nancy Rogers, dean of our Moritz College of Law, to talk about the Selective Investment program in that college. Nancy --

Dean Nancy H. Rogers: [PowerPoint Presentation]

Thank you very much, Ed. The momentum that was created by the Selective Investment grant to the Moritz College three years ago has already propelled us into national distinction in a few areas and seems poised to do that in several other areas. There are several early key indicators of great progress: 1) in our ability to recruit other scholars to join our faculty; 2) in our student credentials and the change in them over the last two years; and 3) in the enthusiastic reaction of our alumni.

SELECTIVE INVESTMENTS – HISTORY, PHYSICS, AND LAW (contd)

Dean Rogers: (contd)

Beginning with the hiring, the Selective Investment Award permitted us to hire eight faculty in key areas we wanted to build, as well as to increase our interdisciplinary work. We have seven of those offers accepted and an eighth offer is out, which we expect to be accepted next week. The hiring will be done a full year earlier than we anticipated in our Selective Investment proposal. In doing that hiring at the junior level, we were able to compete successfully with law schools already ranked in the top 20 nationally and, in fact, in hiring laterally, we were able to hire away from those law schools. We feel these are indications that others are feeling the excitement of the momentum.

Perhaps the most exciting news in term of a concrete indication of the momentum came earlier this week. That was when we learned figures were released that our student credentials in the first year have climbed more rapidly than any other law school in the Big Ten. We also learned earlier this week that the credentials of our current first-year students are higher than or comparable to some of the other law schools already ranked in the top 20 nationally. So this has been an amazing change over the last two years since the Selective Investment grant was awarded.

Our alumni have responded with an enthusiasm that has amazed all of us on the faculty and the staff at the Moritz College. This is one year to the day after Mike Moritz sadly died. It is also a day on which we reflect that right after we received the Selective Investment grant, Mike decided that it was time not to build a very good law school, but to build a truly great law school and gave a \$30 million grant, that included four chairs, to the college.

At each of your places is a pamphlet that shows another chair gift given by Gib Reese to the Law School and several other major gifts. In the last year, five groups of our alumni have created five new designated professorships, one of which you will have the opportunity to approve today. So, it's been an amazing response in terms of our ability to hire, in terms of the student credentials climbing, and in terms of the enthusiasm of our alumni.

It is not just that we want these things for ourselves; we do enjoy that and it is fun to be a part of something that's improving so rapidly. We are also aware that building a great university is difficult to do without having a great law school and we're glad to have that responsibility as well. But we have a sense of the importance of a law school. It produces people like Dan Slane and Bob Duncan, who we are honoring as one our distinguished alumnus today.

As we teach and as we prepare to teach better, we're aware that we have a place in building the democracy that we value in this country. It is not just the truism that one whole branch of government, the judiciary, are graduates of law schools, but also as one looks at the executive branch, three out of the last seven presidents have been lawyers, and half of the current governors of states are lawyers. Looking at the legislative branch, half of the members of the United States Senate are lawyers, including both of Ohio's, and a third of the United States House of Representatives. It is a trust and we feel that the ability to build one of the nation's distinguished law schools is also the ability to contribute to the betterment of the nation.

I want to move now to some of the actions that we've taken to enlarge the faculty and to enhance the excellence of key areas of studies and also to encourage interdisciplinary studies and give you some of the results in those areas. The Moritz College is already ranked in the top three nationally in its dispute resolution program, an area that's the primary area of focus for four of us on the

SELECTIVE INVESTMENTS – HISTORY, PHYSICS, AND LAW (contd)

Dean Rogers: (contd)

faculty and of some interest to others. Josh Stulberg, who coordinates the program, also serves as advisor to the *Ohio State Journal on Dispute Resolution*, which has now become the most frequently cited journal in that field.

Sarah Cole is the coauthor of both the leading legal treatise in mediation and the leading casebook on dispute resolution. Mary Ellen O'Connell, who holds an appointment in the Mershon Center as well, has an upcoming book on international dispute resolution. Charlie Wilson teaches and coaches in the field of negotiation, and I continue to teach the capstone course in the college's certificate program in dispute resolution.

To enhance the excellence in the dispute resolution program through the Selective Investment grant, we've made a joint hire with the Mershon Center of Ellen Deason. Ellen was the editor-in-chief of the *Michigan Law Review*, a U.S. Supreme Court law clerk, and is still a tenured member of the University of Illinois faculty. The word that she is coming has resulted in the formation of a group of faculty -- some of our faculty, faculty from Harvard Law School, and faculty from Fordham Law School -- to work with her in developing a new field, the study of the use of dispute resolution techniques in other nations. This new field might be of use in this country for the most difficult and divisive disputes that we face -- disputes that involve race and ethnicity. Yesterday, we received a \$100,000 check from the Hewlett Foundation that will permit Ellen and the others to move forward with this important work.

Four of our outstanding and relatively new faculty are in the area of criminal law and we knew that they could be used to attract one of the nation's most distinguished criminal law scholars. Sharon Davies has coauthored a book on health care fraud and will become the associate dean for faculty next year, after completing a semester visit at the University of Michigan Law School. Allen Michaels, the current associate dean for faculty, has been elected best professor by the students. He has been selected nationally for the prestigious award for best article by a junior faculty on any subject by the Association of American Law Schools. Kate Federle founded the Justice for Children Project, which focuses on children and delinquency. It has so resonated with our students that we've created a new certificate in the study of children and the law. Doug Berman, a sentencing scholar, has already been honored by the University by the Alumni Distinguished Teaching Award.

In this area, as in several others you'll see, we used a professorship or a chair that was created by Michael Moritz's gift to attract Joshua Dressler, who is one of the top five criminal lawyers in the nation. I am already hearing from scholars at other law schools that we have the leading criminal law faculty in the country. This group of faculty, including Joshua Dressler, have started a brand new journal, *The Ohio State Journal on Criminal Law*, which will publish its first issue in a few months, "Changes in the Criminal Law Since 9/11," to be followed by a second issue, "Changes in Criminal Law Since Enron." We want to acknowledge again that it was the combined efforts of Selective Investment and the gifts of our alumni, including Mike, that have made this possible.

Cyber law and intellectual property have become international and not just national fields of law. Dan Chow is a leading scholar on intellectual property issues, including privacy in the Pacific and Rim nations, and Shel Halpern has focused on European and U.S. intellectual property issues. Peter Swire has rejoined our faculty. He was the first counselor to the President on Privacy for two years and looks at domestic and international privacy issues in cyber law. Through the Selective Investment grant, Ed Lee joined us last fall from Stanford,

SELECTIVE INVESTMENTS – HISTORY, PHYSICS, AND LAW (contd)

Dean Rogers: (contd)

focusing on the international issues in cyber law and intellectual property. Already the college is beginning to attract substantial numbers of students who have graduated from Bob's department and others in scientific fields and have an interest in this growing field.

In the core of our study is business law and the Selective Investment grant permitted us to add Doug Coe, a law and economics scholar in the field of business. In January, Doug was tapped and became the State Solicitor for the State of Ohio, and so last week the college hired Larry Garvin, a rising star in the business field, from the Florida State law faculty. Larry is now visiting at the University of Texas Law School and will join us this summer.

Then a gift from Gib Reese created the new Reese Chair in Contract Law. We have made an offer to a nationally known scholar, who we expect will accept next week, and will have a formal attachment as well to the Fisher College of Business, permitting us to expand our business law faculty substantially.

Our Selective Investment hire in ethics, Mark Spindleman, is already nationally cited in bioethics. He is being quoted in the national press about every other week. The Selective Investment hire has also permitted us to expand our Center for Law Policy and Social Science. We have an interesting hire here -- Peter Shane, who will join us this summer as director, has been a law school dean longer than I have. He was a member of the Iowa law faculty, then dean at Pittsburgh Law School, and is now in an interdisciplinary position at Carnegie-Mellon University in the cyber area. Peter will bring with him a major grant from the National Science Foundation.

The new Kirwan Institute for the Study of Race and Ethnicity provides another opportunity for interdisciplinary Selective Investment hire. Two months ago John Powell left a chaired professorship at the University of Minnesota Law School to join the Institute as director and to join our faculty and to teach as a chaired professor.

I think you can feel the momentum that has been established in just the three years since the grant. It's a time when we are anxious to tell you how much we appreciate the grant, we're anxious to express to our alumni, and, particularly, Mike Moritz and his family our gratitude for the way in which he built on that momentum for us. We know that it has been the momentum started with the Selective Investment Award that has permitted us to attract these scholars, has permitted us to yield students with rising credentials, and has allowed us to create a variety of new programs for these people to prepare them to take the role that they must play in enriching this democracy.

So we thank you very much for the opportunity that you've given us through this Selective Investment Award.

Provost Ray:

Are there any questions or comments?

Ms. Hendricks:

You mentioned the enormous progress you had made with the incoming class. Where would you put that class relative to the other Big Ten schools? If you would rank their qualifications, do you have any perspective on it?

SELECTIVE INVESTMENTS – HISTORY, PHYSICS, AND LAW (contd)

Dean Rogers:

I do. With respect to the Big Ten, the incoming class is now above the median in the Big Ten. They're not at the top yet, we have a ways to go. I would say that what we have made is a quantum leap. Our applications are up again this year. They were up 55 percent in that two-year period and they're up again this year, beyond that 55 percent, with credentials that appear to be going up again.

Provost Ray:

Any other questions or comments? If not, Mr. Chairman, that concludes the report.

Mr. Patterson:

Thank you, Ed. I continue to be amazed as we sit and listen to the programs and the talent of the faculty, the deans, and the students. To all of you, our recognition and congratulations on such outstanding programs. Over the years that I've been a trustee, it seems that the Department of Physics -- in deference to law and history -- is being recognized everywhere, and what has always amazed me is the teamwork that seems to transpire within your area. I'm sure it is in the others, too. Thank you.

--0--

STUDENT RECOGNITION AWARD

Ms. Habib:

The Student Recognition Award is presented each month by the Board of Trustees to a student in honor of the student's achievement in his or her area of study, service to the University and/or community, and/or research achievements that have been a credit to the college and the University.

This month's recipient is Cullen Buie, who was nominated by Dean Williams in the College of Engineering. Cullen Buie is a student who sets new standards, changes the world around him, and leaves his community a better place. He began his Ohio State experience in the PREFACE Program, Pre-Freshman in Cooperative Education Program, which gives academically talented minority students a head start in engineering.

Cullen has exceptionally high-standardized test scores and grades. He is quick to grasp new concepts and is creative in applying them to new situations. Mr. Buie is also a deeply committed student who is always sharing his immense talents to help the needy.

Since his freshman year, he has been involved in a curriculum to prepare him for advanced study. As a freshman, Cullen elected to participate in the freshman engineering honors program. This program is designed to challenge well-prepared, first year students by offering access to more advanced levels of study and by encouraging creative abilities and a sustained interest in advanced education and research.

As a research assistant, Cullen designed and built a robot. He entered his project in the University-wide 2001 Denman Undergraduate Research Forum and won the top sophomore award. Subsequently, he has presented this research to The Ohio State University's Board of Trustees and the State of Ohio Board of Regents. More recently, his research has been featured in University academically-focused advertisements at a football game, on the web page, and

STUDENT RECOGNITION AWARD (contd)

Ms. Habib: (contd)

in the Columbus *Dispatch*. In 2002, he also entered the Denman competition, where he won the top junior award and was second runner-up overall.

Cullen is not only a scholar. He is a highly competent student leader. Building on his high school background where he played an active role in helping other African-American males to succeed in his high school, he has assumed leadership roles in the National Society of Black Engineers and the newly formed minority-engineering student honorary, Lambda Xi. He is also a member of Tau Beta Pi.

At first, his leadership skills were attributed to experience. However, it is very evident that he is well organized, self-confident, focused, and plans ahead and truly listens. He is adept at articulating his views and gaining group consensus. Peers, faculty, and administrators alike respect him and value his opinions and contributions.

In conclusion, Cullen Buie is an exceptional young man who is totally committed to academic excellence. He has won numerous awards and recognitions for his academic achievement and research efforts, yet he is one of the most active students on campus. He absolutely believes that he can achieve at the highest level and whatever endeavors he undertakes.

Being a student myself, it is a great honor for me to be able to present a student like Cullen Buie to the Board of Trustees. The Board appreciates the chance to meet students, especially ones who exemplify exactly how bright and committed the students at Ohio State really are. Congratulations, Cullen.

Mr. Cullen R. Buie:

I'd like to thank Ms. Habib for that wonderful introduction. I don't know who you were talking about, that guy sounded so fantastic. You're going to have to send me a copy of that. I'd also like to thank Dean Williams in his absence for nominating me for this very prestigious award. It was totally unexpected.

As Dr. Holbrook said earlier, I've been very busy with things regarding Affirmative Action around campus and in several other organizations. It was a very pleasant surprise to find that I would be winning this award. I'd like to thank the Board of Trustees for presenting it and for allowing me to come and speak before you this morning. I'm so excited about Ohio State. After seeing the presentations from the College of Law and the Departments of History and Physics, I'm very glad to be here. I'd also like to introduce a possible future award recipient, my younger brother.

While I'm here, I might as well share some other good news with you. I'm looking at going to graduate school in engineering and I've been accepted at Stanford, Cornell, Berkeley, and MIT, so I have a hefty decision to make.

I'd like to thank all of you for all of your hard work. It is really the work that you've done, the work of past presidents and President Holbrook, and all the faculty here at this University that has allowed students like me to have the opportunities that we're going to have in the future. Thank you.

Mr. Patterson:

Cullen, our thanks is to you for all that you do, and the leadership and the model that you serve for all others, not the least of which is your brother.

STUDENT RECOGNITION AWARD (contd)

Mr. Buie:

Thank you.

--0--

CONSENT AGENDA

President Karen A. Holbrook:

We have eleven resolutions on the Consent Agenda today as follows:

**AMENDMENTS TO THE BYLAWS AND RULES AND REGULATIONS
OF THE MEDICAL STAFF OF THE OHIO STATE UNIVERSITY HOSPITALS**

Resolution No. 2003-90

Synopsis: The amendments to the *Bylaws and Rules and Regulations of the Medical Staff* of The Ohio State University Hospitals are recommended for approval.

WHEREAS The Ohio State University Hospitals Board pursuant to bylaw 3335-101-04 of the Hospitals Board Bylaws is authorized to recommend to the Board of Trustees the adoption of amendments to the *Bylaws and Rules and Regulations of the Medical Staff* of The Ohio State University Hospitals; and

WHEREAS the proposed amendments to the *Bylaws and Rules and Regulations of the Medical Staff* of The Ohio State University Hospitals were approved by the University Hospitals Board on January 23, 2003, as follows:

Amended Bylaws of the Medical Staff

3335-43-04 Membership.

(A) Qualifications.

(1) through (4) unchanged.

(5) An applicant for membership shall at the time of appointment or reappointment, be and remain board certified in a medical specialty approved by at least one of the American medical association and American board of medical specialties, or other applicable certifying boards, including certifying boards if applicable for doctors of osteopathy, podiatry, psychology, and dentistry. All applicants must be and remain certified within the specific areas for which they have requested clinical privileges. An applicant who is an active candidate for board certification at the time of initial appointment or reappointment shall have three years from the date eligibility was first attained to become board certified. Board certification is a continuing requirement. Whenever recertification is required by a sub-specialty board approved herein, applicants for appointment or reappointment shall meet the terms of recertification established by their respective sub-specialty board or boards. Failure to meet or maintain board certification shall result in immediate termination of membership on the medical staff of the Ohio state university hospitals. This requirement may be waived by action of the medical staff administrative committee, upon the recommendation of the credentials committee or the medical director of the Ohio state university hospitals, or as specifically provided in these bylaws.

(6) Unchanged.

**AMENDMENTS TO THE *BYLAWS AND RULES AND REGULATIONS*
OF THE MEDICAL STAFF OF THE OHIO STATE UNIVERSITY HOSPITALS (contd)**

Amended Bylaws of the Medical Staff (contd)

(B) Unchanged.

(C) Terms of appointment. Initial appointment to the medical staff shall be for a period extending to the end of the fiscal year (first of July through thirtieth of June) or following fiscal year depending upon date on which applicant first becomes eligible for reappointment, not to exceed twenty-four months. Reappointment to the medical staff shall be done on a regular basis for a period not to exceed twenty-four months. Initial appointment, except appointment to the honorary medical or limited staff categories, shall be provisional for six months regardless of the date of the appointment. During the period of the provisional appointment all applicants shall be subject to continuous review and reconsideration pursuant to these bylaws. Following the six-month period if no adverse action has been taken the appointment shall no longer be provisional.

Balance unchanged.

3335-43-08 Organization of the medical staff.

(A) Unchanged.

(B) Names of clinical departments and divisions.

(1) and (2) unchanged.

(3) Family medicine

Sports medicine

(4) through (12) unchanged.

~~(13) Preventive medicine~~

~~(14)~~(13) Psychiatry. The following divisions are designated:

General psychiatry
Child psychiatry
Geriatric psychiatry
Health psychology

~~(15)~~(14) Radiology. The following divisions are designated:

Diagnostic radiology
Nuclear medicine
Radiation oncology

~~(16)~~(15) Surgery. The following divisions are designated:

General surgery
Neurologic surgery
Pediatric surgery
Plastic surgery
Surgical oncology
Thoracic and cardiovascular surgery
Transplant
Urologic surgery
Vascular

**AMENDMENTS TO THE *BYLAWS AND RULES AND REGULATIONS*
OF THE MEDICAL STAFF OF THE OHIO STATE UNIVERSITY HOSPITALS (contd)**

Amended Bylaws of the Medical Staff (contd)

~~(17)~~(16) Dentistry. The following divisions are designated:

General dentistry
Oral and maxillofacial surgery

(C) and (D) unchanged.

3335-43-09 Elected officers of the medical staff of the Ohio state university hospitals.

(A) through (E) unchanged.

(F) Election of officers.

(1) All officers (other than at-large officers) shall be elected by a majority of those voting by written or electronic ballot of the attending staff ~~at a meeting scheduled for that purpose.~~

(2) The nominating committee shall be composed of five members. The chief of staff and the chief of staff-elect shall serve on the committee and shall select three other members for the committee. ~~the~~ The chief of staff-elect shall be its chairperson. ~~Three other members of the committee shall be nominated from the floor and elected, by a plurality upon written ballot, at a meeting scheduled for that purpose.~~

(3) Nominations for officers shall be accepted from any member of the medical staff and shall be submitted either electronically or in writing to the nominating committee.

~~(3)~~

(4) The committee's nominees shall be submitted in writing to all voting members of the attending staff no later than March first of the election year.

~~(4) Nominations for officers shall be accepted from the floor.~~

(5) Unchanged.

(6) Grounds for removal of an elected medical staff officer shall be malfeasance, misfeasance, or nonfeasance in office as documented by written charges submitted to the chief of staff, or to the medical director if charges are filed against the chief of staff. An officer may be removed from the elected position by a majority vote upon written or electronic ballot of the attending staff following a regularly scheduled meeting or a meeting scheduled for that purpose. ~~Grounds for removal shall be malfeasance, misfeasance, or nonfeasance in office as documented by written charges submitted to the chief of staff, or to the medical director if charges are filed against the chief of staff.~~

(G) and (H) unchanged.

3335-43-10 Administration of the medical staff of the Ohio state university hospitals.

(A) Unchanged.

(B) Medical staff committees.

(1) Appointments:

Appointments to all medical staff committees except the medical staff administrative committee and the nominating committee shall be made jointly by the chief of staff, chief

**AMENDMENTS TO THE *BYLAWS AND RULES AND REGULATIONS*
OF THE MEDICAL STAFF OF THE OHIO STATE UNIVERSITY HOSPITALS (contd)**

Amended Bylaws of the Medical Staff (contd)

of staff-elect, and the medical director with consultation with the executive director of the Ohio state university hospitals and ~~approved by the respective deans of the college of medicine and public health or dentistry and the university hospitals board.~~ Unless otherwise provided by these bylaws, all appointments to medical staff committees shall be for one year and may be renewed. The chief of staff, medical director, and the executive director of the Ohio state university hospitals may serve on any medical staff committee as an ex officio member without vote.

(2) Unchanged.

Balance unchanged.

Amended Medical Staff Rules and Regulations

84-03 Attending assignment.

(A) Unchanged.

(B) Alternate attending medical staff member coverage. Each member of the medical staff shall designate on his or her medical staff application one or more members of the attending or courtesy medical staff who have accepted this responsibility and who shall be called to attend his or her patients if the responsible attending medical staff member is not available. The chief of the medical staff member's clinical department, or the medical director or his designee shall have authority to ~~call~~ contact any member of the medical staff and arrange for coverage should the attending medical staff member and the alternate be unavailable. If the chief of the medical staff member's clinical department, or the medical director or his designee is unavailable, the emergency department physician on duty is responsible for arranging appropriate medical coverage until the attending medical staff member is available to care for the patient. (B/T 9/6/2002, B/T 3/5/2003)

84-12 Medical information management committee.

(A) Unchanged.

(B) Each member of the medical staff shall conform to the policies established by the medical information management committee, including the following:

(1) Chart contents

The attending medical staff member shall be responsible for the preparation of a complete medical record of each patient admitted to the hospital. This record shall include the following:

(a) through (r) unchanged.

(s) ~~Every medication ordered or prescribed on an inpatient~~ Any and all orders related to the patient's care.

(t) through (y) unchanged.

(4) through (11) unchanged.

Balance unchanged.

**AMENDMENTS TO THE *BYLAWS AND RULES AND REGULATIONS*
OF THE *MEDICAL STAFF OF THE OHIO STATE UNIVERSITY HOSPITALS* (contd)**

Amended Medical Staff Rules and Regulations (contd)

NOW THEREFORE

BE IT RESOLVED, That the amendments to the *Bylaws and Rules and Regulations of the Medical Staff* of The Ohio State University Hospitals be adopted as recommended and approved January 23, 2003, by the University Hospitals Board.

**AMENDMENTS TO THE *RULES OF THE UNIVERSITY FACULTY*
AND *BYLAWS OF THE UNIVERSITY SENATE***

Resolution No. 2003-91

Synopsis: Approval of the following amendments to the *Rules of the University Faculty* and *Bylaws of the University Senate* are recommended.

WHEREAS the University Senate pursuant to rule 3335-1-09 of the Administrative Code is authorized to recommend through the President to the Board of Trustees the adoption of amendments to the *Rules of the University Faculty* and *Bylaws of the University Senate* as approved by the University Senate; and

WHEREAS the proposed changes in the *Rules of the University Faculty* and *Bylaws of the University Senate* were approved by the University Senate on February 13, 2003:

Amended Rule

3335-3-21 Director of athletics.

(A) The director of athletics shall be responsible to the ~~vice president for student affairs~~ and shall be appointed under the procedures outlined in rule 3335-3-35 of the Administrative Code. The athletic council (see rule 3335-5-485 of the Administrative Code) shall also be consulted.

(B) and (C) unchanged.

Amended Senate Bylaw

3335-17-06 Apportionment of professional student members.

(A) ~~Five~~ Six professional student members shall be apportioned as follows: one to represent each of the following graduate professional colleges, with five selected randomly from the elected six by the inter-professional council to serve as senators and the sixth to serve as a designated alternate, with the additional stipulation that the designated alternate may not be from the same college as the designated alternate of the previous year:

Dentistry	Medicine and public health	Optometry
Law	<u>Pharmacy</u>	Veterinary medicine

(B) Unchanged.

NOW THEREFORE

**AMENDMENTS TO THE RULES OF THE UNIVERSITY FACULTY
AND BYLAWS OF THE UNIVERSITY SENATE (contd)**

BE IT RESOLVED, That the foregoing amendments to the *Rules of the University Faculty* and *Bylaws of the University Senate* be adopted as recommended by the University Senate.

DISTINGUISHED SERVICE AWARDS

Resolution No. 2003-92

Synopsis: Approval of eight individuals to receive Distinguished Service Awards is proposed.

WHEREAS the President's Cabinet, upon the recommendation of the Committee on Distinguished Service Awards, nominated and recommend eight individuals for approval by the Board of Trustees to receive the Distinguished Service Award at a time convenient to the University and the recipients:

Kenneth L. Coleman
Rodney J. Harrison
Gerald M. Reagan
Robert F. Reusché
Ralph A. Rockow
Norman M. Stanley
Charles C. Warner
Micki Zartman

WHEREAS these awards are given in recognition of outstanding and distinguished service by these individuals to The Ohio State University:

NOW THEREFORE

BE IT RESOLVED, That, in accordance with action taken by the Board of Trustees in 1952, the Distinguished Service Awards be approved for awarding as designated above.

HONORARY DEGREES

Resolution No. 2003-93

Synopsis: The awarding of honorary degrees is recommended for approval.

WHEREAS the Committee on Honorary Degrees and the University Senate, pursuant to rule 3335-5-488 of the Administrative Code, have approved for recommendation to the Board of Trustees awarding of an honorary degree as listed below:

Avery Cardinal Dulles

Doctor of Humane Letters

and

WHEREAS pursuant to paragraph (B)(4) of rule 3335-1-03 of the Administrative Code, the President, after consultation with the Steering Committee of the University Senate, recommended to the Board of Trustees awarding of an honorary degree as listed below:

William E. Kirwan

Doctor of Education

HONORARY DEGREES (contd)

NOW THEREFORE

BE IT RESOLVED, That the above honorary degrees be awarded in accordance with the recommendation at a time convenient to the University and the recipients.

DEGREES AND CERTIFICATES - WINTER QUARTER COMMENCEMENT

Resolution No. 2003-94

Synopsis: Approval of Degrees and Certificates for Winter Quarter is proposed.

WHEREAS pursuant to paragraph (E) of rule 3335-1-06 of the Administrative Code, the Board has authority for the issuance of degrees and certificates; and

WHEREAS the faculties of the colleges and schools shall transmit, in accordance with rule 3335-9-29 of the Administrative Code, for approval by the Board of Trustees the names of persons who have completed degree and certificate requirements:

NOW THEREFORE

BE IT RESOLVED, That the degrees and certificates be conferred on March 21, 2003, to those persons who have completed the requirements for their respective degrees and certificates and are recommended by the colleges and schools, and that the names of those persons awarded degrees and certificates be included in the minutes of this meeting.

PERSONNEL ACTIONS

Resolution No. 2003-95

BE IT RESOLVED, That the personnel actions as recorded in the Personnel Budget Records of the University since the February 7, 2003 meeting of the Board, including the following Appointments, Appointment of Chairperson, Extension of Principal Administrative Official, Professional Improvement Leaves, Promotion/Tenure, and Emeritus Titles as detailed in the University Budget be approved; and

BE IT FURTHER RESOLVED, That Resolution 77-92 and the provisions of the February 6, 1959 Report of the Committee on Retirement and Insurance, be waived to allow for the reappointment of Tony Tripodi as Dean of the College of Social Work.

Appointments

Name: EDWARD B. FOLEY
Title: Professor (The Robert M. Duncan/Jones Day Designated Professorship in Law)
College: Moritz College of Law
Term: March 5, 2003, through March 4, 2008

Name: R. ELLYN PERRONE
Title: Vice President
Office: Government Relations
Effective: April 1, 2003
Present Position: Assistant Vice President for Administration and Special Liaison to the George Bush School of Government and Public Service, Texas A&M, University, College Station, Texas

PERSONNEL ACTIONS (contd)

Appointments (contd)

Name: PETER M. SHANE
Titles: Professor (The Joseph S. Platt – Porter, Wright, Morris & Arthur Professorship in Law) and Director of the Center for Law, Policy and Social Science
College: Moritz College of Law
Term: August 16, 2003, through August 15, 2006
Present Position: Professor, School of Law, University of Pittsburgh, Pittsburgh, PA

Name: PENG G. WANG
Title: Ohio Eminent Scholar in Macromolecular Structure and Function
Department: Biochemistry
Effective: October 1, 2003
Present Position: Professor, Department of Chemistry, Wayne State University, Detroit, MI

Appointment of Chairperson

January 1, 2003, through December 31, 2003

Near Eastern Languages and Cultures

Richard Davis*

*Interim

Extension of Principal Administrative Official

TONY TRIPODI, Dean, College of Social Work, effective July 1, 2004, through June 30, 2005, pursuant to rule 3335-1-03 (R) of the Administrative Code.

Professional Improvement Leaves

PATRICIA A. LATHER, Professor, Department of Educational Policy and Leadership, effective Autumn Quarter 2003, Winter Quarter and Spring Quarter 2004.

PAUL E. BELLAIR, Associate Professor, Department of Sociology, effective Autumn Quarter 2003, Winter Quarter and Spring Quarter 2004.

DAVID LANDSBERGEN, Associate Professor, School of Public Policy and Management, effective Spring Quarter 2003.

Professional Improvement Leave—Change of Dates

NEIL E. SMECK, Professor, School of Natural Resources, change leave from Winter Quarter and Spring Quarter 2003, to Spring Quarter 2003.

Promotion/Tenure

COLLEGE OF MEDICINE AND PUBLIC HEALTH

PROMOTION TO ASSOCIATE PROFESSOR WITH TENURE

MICHAEL X. ZHU, Neuroscience – effective 3/1/03

Emeritus Titles

CHARLES F. ADAMS, JR., School of Public Policy and Management, with the title Professor Emeritus, effective April 1, 2003.

PERSONNEL ACTIONS (contd)

Emeritus Titles (contd)

JO M. JONES, Ohio State University Extension, with the title Associate Professor Emeritus, effective April 1, 2003.

ELLA M. BARD, Ohio State University Extension, with the title Assistant Professor Emeritus, effective April 1, 2003.

BEVERLY J. KEIL, Ohio State University Extension, with the title Assistant Professor Emeritus, effective April 1, 2003.

RESOLUTIONS IN MEMORIAM

Resolution No. 2003-96

Synopsis: Approval of Resolutions in Memoriam is proposed.

RESOLVED, That the Board adopt the following Resolutions in Memoriam and that the President be requested to convey a copy to the families of the deceased.

Jacob E. Davis

The Board of Trustees of The Ohio State University expresses its sorrow upon the death on February 28, 2003, of Jacob E. Davis, of Naples, Florida, former member of the Board of Trustees.

Mr. Davis was born in Beaver, Ohio, and graduated from The Ohio State University in 1927 where he was a member of Phi Beta Kappa. He received a law degree from Harvard University in 1930 and began practicing law in Waverly, Ohio. He served two terms as Pike County prosecuting attorney. He was elected twice to the Ohio General Assembly and was majority floor leader of the House until he became Judge of the Court of Common Pleas for Pike County in 1937. Mr. Davis was a member of the House of Representatives from 1941-43 when he became a special assistant to the Secretary of the Navy, James W. Forrestal, and assistant general counsel of the Navy Department.

In 1944, Mr. Davis joined The Kroger Company as a vice president, was elected a director in 1949, executive vice president in 1961, and president in 1962. He was president and chairman of the company until his retirement in 1970. Mr. Davis served on the corporate boards of The Kroger Company, Cincinnati Milacron, Inc., Anchor Hocking Corporation, and Ohio National Life Insurance Co. Mr. Davis later became Of Counsel to the Columbus-based law firm of Vorys, Sater, Seymour & Pease when it opened a Cincinnati office in 1984.

Mr. Davis served on the Board of Trustees of The Ohio State University from 1961-67, and served as its chairman from 1966-67. He chaired the Presidential Search Committee for Ohio State in 1972 that recommended the appointment of President Harold L. Enarson. He was a devoted and generous trustee who, during his tenure, established a fund in Social Work, the Jacob E. Davis Professorship Fund in the College of Law, and was one of the founders of the Novice G. Fawcett Chair in Educational Administration. Mr. Davis, a loyal alum, also served as president of the university's Alumni Association.

For 30 years, Mr. Davis served on the Board of Bethesda, Inc., and was its chairman from 1975-90. He was honored as a "Trustee of the Year" by the Ohio Hospital Association in 1982, and in 1994 received the Bethesda Board's Golder Award. In 1995, he was the recipient of Hospice of Cincinnati's Donna West Volunteer Award. He was known as a volunteer leader in church, non-profit and civic associations, and during his life served the following organizations: chairman of

RESOLUTIONS IN MEMORIAM (contd)

Jacob E. Davis (contd)

the United Appeal Campaign (1957-58); president and chairman of the board of the Community Chest and Council; and co-chairman of the Citizens Committee to Improve Local Government. Mr. Davis was one of the founding members of The Greater Cincinnati Foundation in 1963, and was the first chairman of its Governing Board and the Volunteer Director of the Foundation from 1978-86. In his honor, the Governing Board created the "Jacob E. Davis Volunteer Leadership Award" at the time of his retirement. This award of \$10,000 is presented each year to an outstanding volunteer in the community, who then awards the money to a non-profit organization.

Mr. Davis was honored as a Great Living Cincinnati in 1977-78 and received the Alexis de Tocqueville Award from United Way in 1987.

On behalf of the University community, the Board of Trustees expresses to the family of Jacob E. Davis its deepest sympathy and sense of understanding of their loss. It was directed that this resolution be inscribed upon the minutes of the Board of Trustees and that a copy be tendered to the family as an expression of the Board's heartfelt sympathy.

David L. Moffatt

The Board of Trustees of The Ohio State University expresses its sorrow upon the death, on January 18, 2003, of David L. Moffatt, Professor Emeritus in the Department of Electrical Engineering.

After having served his country in the Merchant Marines during World War II and as a member of the United States Army during the Korean Conflict, Dr. Moffatt enrolled as a student at The Ohio State University in 1953. He obtained the Bachelor of Science degree in 1958, the Master of Science degree in 1961, and the Ph.D. degree in 1967, all in electrical engineering.

After obtaining the M.S. degree, he joined the OSU Antenna Laboratory (now ElectroScience Laboratory) as a research associate. In 1969 he was appointed assistant professor of Electrical Engineering, promoted to the rank of associate professor in 1978, and professor in 1984.

Professor Moffatt was a highly competent researcher, a very effective teacher, and a dedicated servant to his profession. He had a very impressive number of publications in refereed journals, four invited book chapters, and a large number of presentations at professional conferences. He was an invited lecturer in Germany, India, and the Peoples Republic of China. He was a key member of a small number of researchers who pioneered the study of electromagnetic phenomena using time-domain techniques rather than the traditional frequency-domain methods. His work, which was highly regarded by external authorities, included original contributions to the understanding of subsurface detection, transient and impulse responses of radar targets, and radar target discrimination. He was consistently successful in competition for external research funds which supported many graduate students as well as other faculty members.

Professor Moffatt was an effective teacher at both the undergraduate and graduate levels. His teaching was enhanced significantly by his very extensive and productive research activities. All of the M.S. theses and Ph.D. dissertations completed under his guidance resulted in published papers in refereed journals.

Dr. Moffatt's service to his profession was also exemplary. He was a member of several professional organizations related to his technical discipline and served as a regular paper reviewer for the principal one among them, the Institute of Electrical and Electronics Engineers. He also served as a regular proposal reviewer for the National Science Foundation and as an occasional reviewer for other government agencies.

RESOLUTIONS IN MEMORIAM (contd)

David L. Moffatt (contd)

On behalf of the University community, the Board of Trustees expresses to the family of Professor David L. Moffatt its deepest sympathy and sense of understanding of their loss. It was directed that this resolution be inscribed upon the minutes of the Board of Trustees and that a copy be tendered to his family as an expression of the Board's heartfelt sympathy.

John M. Muste

The Board of Trustees of The Ohio State University expresses its sorrow upon the death on September 5, 2002, of John M. Muste, Professor Emeritus in the Department of English.

A native of Mt. Kisco, New York, John Muste was one of three children of the world-renowned peace activist A.J. Muste. He received his B.A. degree from Brown University (where one of his English-major classmates was Joe Paterno) in 1949, his M.A. degree from Miami of Ohio in 1953, and his Ph.D. degree from the University of Wisconsin in 1960. He joined the Ohio State Department of English in 1958 as a specialist in 20th century literature, published *Say That We Saw Spain Die: Literary Consequences of the Spanish Civil War* in 1966, and for more than three decades was a major presence in the teaching, scholarship, and administration of the Ohio State Department of English and its College of Humanities.

He inspired students and colleagues by the critical intelligence manifested in his classroom, his book, and his many scholarly articles; by his administrative talent manifested first as department vice chair and later associate dean of the college; and perhaps above all by his courage and wisdom as a victim of polio. Dr. Muste stood six-and-a-half feet tall. He supported himself on a pair of crutch-canes and, in 1958 when he applied for what was then called a "University handicapped parking permit," he was required to walk up to the second floor of Bricker Hall and give ocular proof of his disability. Neither then nor ever after did he lose the good humor or desert the professionalism that enabled him to affect students, colleagues, and the public in an extraordinary way.

The department's Muste Award was established to honor his incisive and nurturing attention to the work of our graduate students. He was honored (silently) by the State of Ohio, which, in response to his Columbus *Dispatch* op-ed, "Ohio, The Outhouse State," began constructing disability-accessible facilities at its highway rest areas. And he has long been honored in the hearts of colleagues who found daily sustenance in his wisdom and wit.

On behalf of the University community, the Board of Trustees expresses to the family of Professor John M. Muste its deepest sympathy and sense of understanding of their loss. It was directed that this resolution be inscribed upon the minutes of the Board of Trustees and that a copy be tendered to his family as an expression of the Board's heartfelt sympathy.

Gus C. Pappas

The Board of Trustees of The Ohio State University expresses its sorrow upon the death on January 10, 2003, of Gus C. Pappas, D.D.S., Professor Emeritus in the College of Dentistry.

Dr. Pappas was a native of Fairpoint, Belmont County, Ohio, and graduated from high school in nearby St. Clairsville in 1935. He attended The Ohio State University as a pre-dental student and in 1938 was admitted to the College of Dentistry from which he graduated in 1942.

He was a member of the first class of dental students to be drafted into the military in World War II. He served as a dental officer and at war's end returned to Ohio to enter practice in Worthington. In 1956, he joined the College of Dentistry faculty as a part-time instructor in radiology until 1964, when he was appointed as an assistant professor. He was a member of the American Dental Association and the American Academy of Dental Radiology. Dr. Pappas had a

RESOLUTIONS IN MEMORIAM (contd)

Gus C. Pappas (contd)

number of tours on the hospital ship HOPE. He remained a full-time faculty member until his retirement in 1979 and was named Professor Emeritus.

He was a talented, artistic man who enjoyed creating wood objects for which he received a number of prizes and commendations. He was a member of the International Wood Collector's Society. In recent years, he took up digital photography and created a number of works of art.

On behalf of the University community, the Board of Trustees expresses to the family of Dr. Gus C. Pappas its deepest sympathy and sense of understanding of their loss. It was directed that this resolution be inscribed upon the minutes of the Board of Trustees and that a copy be tendered to his family as an expression of the Board's heartfelt sympathy.

REPORT OF RESEARCH CONTRACTS AND GRANTS

Resolution No. 2003-97

Synopsis: The reports on research and other sponsored program contracts and grants and the summary for January 2003 are presented for Board acceptance.

WHEREAS monies are solicited and received on behalf of the University from governmental, industrial, and other agencies in support of research, instructional activities, and service; and

WHEREAS such monies are received through The Ohio State University Research Foundation:

NOW THEREFORE

BE IT RESOLVED, That the research agreement between The Ohio State University and The Ohio State University Research Foundation for the contracts and grants reported herein during the month of January 2003 be approved.

REPORT ON UNIVERSITY DEVELOPMENT

Resolution No. 2003-98

Synopsis: The report on the receipt of gifts and the summary for January 2003 are presented for Board acceptance.

WHEREAS monies are solicited and received on behalf of the University from alumni, industry, and various individuals in support of research, instructional activities, and service; and

WHEREAS such gifts are received through The Ohio State University Development Fund and The Ohio State University Foundation; and

WHEREAS this report includes the establishment of The Robert M. Duncan/Jones Day Designated Professorship in Law; and

WHEREAS this report includes the establishment of nine (9) new named endowed funds and the amendment of six (6) named endowed funds:

NOW THEREFORE

REPORT ON UNIVERSITY DEVELOPMENT (contd)

BE IT RESOLVED, That the acceptance of the report from The Ohio State University Development Fund and The Ohio State University Foundation during the month of January 2003 be approved.

TOTAL UNIVERSITY PRIVATE SUPPORT

July through January
2001-02 Compared to 2002-03

GIFT RECEIPTS BY DONOR TYPE

	Dollars July through January		
	<u>2001</u>	<u>2002</u>	<u>%Change</u>
Individuals:			
Alumni (Current Giving)	\$22,925,456	\$25,355,464	11
Alumni (From Bequests)	<u>2,630,919</u>	<u>2,478,185</u>	(6)
Alumni Total	\$25,556,375	\$27,833,649	9
Non-Alumni (Current Giving)	\$10,292,270	\$12,301,137	20
Non-Alumni (From Bequests)	<u>2,728,117</u>	<u>3,747,130</u>	37
Non-Alumni Total	\$13,020,387	\$16,048,267	23
Individual Total	\$38,576,762	\$43,881,916	14 ^A
Corporations/Corp/Foundations	\$24,020,026	\$26,037,311	8 ^B
Private Foundations	\$14,329,142	\$12,386,897	(14) ^C
Associations and Other Organizations	<u>\$2,736,754</u>	<u>\$4,789,977</u>	75 ^D
Total	\$79,662,684	\$87,096,101	9

NOTES

- A Individual giving is up 14% largely due to the fact that gifts of \$10,000 or more are up 17% (344 gifts for \$27.2 million last year; 399 gifts for \$31.8 million this year).
- B Giving from corporations at the \$10,000 or more level is up 11% for July 2002 – January 2003 (\$21.6 million from 424 gifts this year; \$19.4 million from 394 gifts last year).
- C Gifts at the \$10,000 or more level from foundations are down 13% for July 2002 – January 2003 compared with the same period last year (141 gifts for \$13.7 million last year; 149 gifts for \$11.9 million this year).
- D Giving from associations and other organizations at the \$10,000 or more level is up 124% for July – January of the fiscal year (\$3.8 million from 60 gifts this year; \$1.7 million from 56 gifts last year).

REPORT ON UNIVERSITY DEVELOPMENT (contd)

TOTAL UNIVERSITY PRIVATE SUPPORT (contd)

July from January
2001-02 Compared to 2002-03

GIFT RECEIPTS BY PURPOSE

	Dollars July through January		
	<u>2001</u>	<u>2002</u>	<u>% Change</u>
Gift Receipts to Current Use and Endowment Funds:			
Buildings/Equipment	\$14,630,117	\$17,990,718	23
Faculty Support	\$7,883,346	\$9,069,035	15
Program Support	\$42,357,304	\$44,198,273	4
Student Financial Aid	\$8,919,226	\$10,967,685	23
Annual Funds-Colleges/Departments	\$5,120,132	\$4,390,482	(14)
Annual Funds-University	<u>\$752,559</u>	<u>\$479,908</u>	(36)
Total	\$79,662,684	\$87,096,101	9

GIFT ADDITIONS TO ENDOWMENT

Dollars
July through January

<u>2001-02</u>	<u>2002-03</u>	<u>% Change</u>
\$25,022,292	\$27,663,654	11

REPORT ON UNIVERSITY DEVELOPMENT (contd)
THE OHIO STATE UNIVERSITY DEVELOPMENT FUND

	<u>Previous Gifts</u>	<u>Current Gifts</u>	<u>Total Gifts</u>
<u>Establishment of Named Designated Professorship</u>			
<p>The Robert M. Duncan/Jones Day Designated Professorship in Law (Used to support a professorship position in The Michael E. Moritz College of Law; provided by gifts made by Moritz College of Law alumni employed by Jones Day) (\$37,500.00 per year for five years)</p>			
<u>Establishment of Named Endowed Funds</u>			
<p>Ice Core Research Endowment Fund (Used to support research activities of the OSU ice core research paleoclimate group; provided by funds from the College of Mathematical and Physical Sciences and gifts from alumni, faculty, and staff)</p>		\$61,300.00	\$61,300.00
<p>Undergraduate Physics Research Endowment Fund (Used to provide scholarship support in the Department of Physics; provided by gifts from Carl E. Nielsen)</p>		\$28,908.85	\$28,908.85
<p>The Edward J. "Ned" Taaffe Memorial Fund in Geography (Used to recognize Ned Taaffe in perpetuity with the initial purpose of ensuring continuation of the Edward J. Taaffe Colloquium Series; provided by gifts from friends, relatives, and corporate friends of the Department of Geography)</p>		\$26,747.00	\$26,747.00
<u>Change in Description of Named Endowed Fund</u>			
The W. Keith Davis Memorial Scholarship Fund			
<u>Change in Name of Named Endowed Funds</u>			
<p>From: The Marshall Cox Fund for the Center for Socio-Legal Studies To: The Marshall and Nathalie Cox Fund for Socio-Legal Studies</p>			
<p>From: Ohio Eminent Scholar in Protein Engineering To: Ohio Eminent Scholar in Macromolecular Structure and Function</p>			

REPORT ON UNIVERSITY DEVELOPMENT (contd)

THE OHIO STATE UNIVERSITY FOUNDATION

	<u>Previous Gifts</u>	<u>Current Gifts</u>	<u>Total Gifts</u>
<u>Establishment of Named Endowed Funds</u>			
The Paul G. Althouse Endowment Fund (Used to support the Department of Animal Sciences' Meat Judging Team; provided by gifts from Phyllis M. Althouse, family, and friends)		\$30,190.00	\$30,190.00
Fredrick Ives Chair's Scholarship Fund (Used to provide undergraduate scholarships for students in the Department of Food, Agricultural, and Biological Engineering in the College of Food, Agricultural, and Environmental Sciences or in the College of Engineering; provided by gifts from alumni and faculty)		\$26,281.00	\$26,281.00
The Ruth and Jesse Owens Endowed Scholarship Fund (Used to support socio-economically disadvantaged students; provided by gifts from the Owens Family and The Jesse Owens Foundation)		\$26,000.00	\$26,000.00
The David J. Ryan Scholarship Fund in Metals Casting (Used to support need-based scholarships to College of Engineering students; provided by a gift from David J. Ryan)		\$25,510.50	\$25,510.50
The R. Kirby Barrick Agricultural Education Fund (Used to support an annual symposium and/or similar activities to foster further development of agricultural teacher education; provided by gifts from Dr. R. Kirby Barrick)		\$25,043.00	\$25,043.00
The General Dynamics Land Systems Science and Engineering Scholarship Fund (Used to support a scholarship for students at OSU-Lima pursuing a degree in mechanical, electrical, industrial, or software engineering; provided by a gift from General Dynamics Land Systems)		\$25,000.00	\$25,000.00
<u>Change in Description of Named Endowed Funds</u>			
The Bernard V. Fultz Family Scholarship Fund			
Mager Family Scholarship Fund			

REPORT ON UNIVERSITY DEVELOPMENT (contd)

THE OHIO STATE UNIVERSITY FOUNDATION (contd)

	<u>Previous Gifts</u>	<u>Current Gifts</u>	<u>Total Gifts</u>
<u>Change in Name of Named Endowed Fund</u>			
From: The Billy Joe Armstrong Football Scholarship Fund			
To: The Greer Steel Company Athletic Football Scholarship Fund			
Total	_____	\$274,980.35	\$274,980.35

THE OHIO STATE UNIVERSITY DEVELOPMENT FUND

Establishment of Named Designated Professorship

The Robert M. Duncan/Jones Day Designated Professorship in Law

The Robert M. Duncan/Jones Day Designated Professorship in Law at The Michael E. Moritz College of Law was established on March 5, 2003, by the Board of Trustees of The Ohio State University. It is being created as a result of the gifts made by Moritz College of Law alumni employed by Jones Day.

A sum of \$37,500 per year will be spent over a five-year period which will provide salary and research support of a professorship position at the Moritz College of Law. Appointment to the professorship shall be recommended by the dean of the Moritz College of Law and provost and approved by the Board of Trustees.

The designated professorship may be renewed at the prevailing amount and term at the time of renewal.

(\$37,500.00 per year for five years)

Establishment of Named Endowed Funds

Ice Core Research Endowment Fund

The Ice Core Research Endowment Fund was established on March 5, 2003, by the Board of Trustees of The Ohio State University, with funds received as a result of the 2002 Common Wealth Award of Distinguished Service bestowed upon Drs. Lonnie G. Thompson (M.S., 1973; Ph.D., 1976) and Ellen Mosley-Thompson (M.A., 1975; Ph.D., 1979) of Columbus, Ohio; funds from the College of Mathematical and Physical Sciences; and gifts from other alumni, faculty, and staff.

All gifts are to be invested in the University's permanent endowment fund, under the rules and regulations adopted by the Board of Trustees of The Ohio State University, with the right to invest and reinvest as occasion dictates.

The Ice Core Research Endowment Fund is being established to support current and future research activities of the ice core research paleoclimate group at The Ohio State University. The principle objectives of the fund are to support: (1) the acquisition of a global array of ice cores that provide high-resolution climatic and environmental histories, and (2) the preservation of the frozen ice core archive in storage facilities at The Ohio State University for future study.

REPORT ON UNIVERSITY DEVELOPMENT (contd)

THE OHIO STATE UNIVERSITY DEVELOPMENT FUND (contd)

Establishment of Named Endowed Funds (contd)

Ice Core Research Endowment Fund (contd)

The annual income shall be used to support the efforts of the ice core research group, including students engaged in this research. All expenditures shall be initiated at the discretion of Dr. Lonnie G. Thompson, Distinguished University Professor in the Department of Geological Sciences, or his successor, with the approval of the chairperson of the Department of Geological Sciences and the dean of the College of Mathematical and Physical Sciences.

Should the Ice Core Research Group cease to exist at some future date, the proceeds from this fund shall then be used for the support and maintenance of the frozen archive. Should, at some point in the distant future, the maintenance of the OSU ice core archive no longer be necessary, then it is the desire of the donors that the remaining funds should be distributed, in equal increments, to the Byrd Polar Research Center and the Department of Geological Sciences in order to establish two new endowments at the discretion of the corresponding director, chairperson, or program administrative officer.

It is the desire of the donors that this fund should benefit the University in perpetuity. If the need for this fund should cease to exist or so diminish as to provide unused income, then another use shall be designated by the Board of Trustees in consultation with the appropriate college dean, department chairperson, or program administrative officer in order to carry out the desire of the donors.

\$61,300.00

Undergraduate Physics Research Endowment Fund

The Undergraduate Physics Research Endowment Fund was established on March 5, 2003, by the Board of Trustees of The Ohio State University with gifts from Carl E. Nielsen, Professor Emeritus in the Department of Physics, of Dublin, Ohio.

All gifts are to be invested in the University's Permanent Endowment Fund, under the rules and regulations adopted by the Board of Trustees of The Ohio State University, with the right to invest and reinvest as occasion dictates.

The annual income shall be used to provide undergraduate scholarship support for one or more students in the Department of Physics. This support will be granted while the students are performing research with a faculty member in the Department. The recipient(s) will be chosen by the chairperson of the Department of Physics, with preference for those doing their research in an area with potential applications to efforts to maintain a sustainable global environment. Scholarships will be awarded in consultation with the University Committee on Student Financial Aid.

In any given year that the endowment income is not fully expended, the unused portion should be reinvested in the endowment principal.

It is the desire of the donor that this fund should benefit the University in perpetuity. If the need for this fund should cease to exist or so diminish as to provide unused income, then another use shall be designated by the Board of Trustees in consultation with the appropriate college dean, department chairperson, or program administrative officer in order to carry out the desire of the donor.

\$28,908.85

REPORT ON UNIVERSITY DEVELOPMENT (contd)

THE OHIO STATE UNIVERSITY DEVELOPMENT FUND (contd)

Establishment of Named Endowed Funds (contd)

The Edward J. "Ned" Taaffe Memorial Fund in Geography

The Edward J. "Ned" Taaffe Memorial Fund in Geography was established on March 5, 2003, by the Board of Trustees of The Ohio State University with gifts from friends, relatives and corporate friends of the Department of Geography of The Ohio State University.

All gifts are to be invested in the University's Permanent Endowment Fund, under the rules and regulations adopted by the Board of Trustees of The Ohio State University, with the right to invest and reinvest as occasion dictates.

The annual income shall be used at the discretion of the chairperson in the Department of Geography to recognize Ned Taaffe in perpetuity with the initial purpose of ensuring continuation of the Edward J. Taaffe Colloquium Series. This series began November 1996, with Ned as the first guest, and since then two per year have been held, one focusing on human geography, the other on physical geography.

It is the desire of the donors that this fund should benefit the University in perpetuity. If the need for this fund should cease to exist or so diminish as to provide unused income, then another use shall be designated by the Board of Trustees in consultation with the appropriate college dean, department chairperson, or program administrative officer in order to carry out the desire of the donors.

\$26,747.00

Change in Description of Named Endowed Fund

The W. Keith Davis Memorial Scholarship Fund

The W. Keith Davis Memorial Scholarship Fund was established March 1, 1985, by the Board of Trustees of The Ohio State University with gifts to The Ohio State University Development Fund from Gerald A. and Betty L. (B.S., 1949) Davis, of Marion, Ohio. The description was revised on March 5, 2003.

All gifts are to be invested in the University's Permanent Endowment Fund, under the rules and regulations adopted by the Board of Trustees of The Ohio State University, with the right to invest and reinvest as occasion dictates.

Fifty percent of the annual income shall be used to provide scholarship assistance to qualified students of sophomore standing or higher who are enrolled at The Ohio State University, Marion Campus. The selection of the scholarship recipient(s) will be made by the University Committee on Student Financial Aid upon the recommendation of the dean and director of The Ohio State University at Marion. The remaining fifty percent of the income shall be reinvested to principal.

Should the need for this fund cease to exist or so diminish as to provide unused income, then the income may be used for any purpose whatsoever as determined by the Board of Trustees with preference being given to recommendations from the person or committee then responsible for student scholarship awards.

REPORT ON UNIVERSITY DEVELOPMENT (contd)

THE OHIO STATE UNIVERSITY DEVELOPMENT FUND (contd)

Change in Name of Named Endowed Funds

The Marshall and Nathalie Cox Fund for Socio-Legal Studies

The Marshall Cox Fund for the Center for Socio-Legal Studies was established April 3, 1998, by the Board of Trustees of The Ohio State University with gifts to The Ohio State University Development Fund from Marshall Cox (J.D., summa cum laude, 1958), of New York, New York. The name was revised on March 5, 2003.

All gifts are to be invested in the University's Permanent Endowment Fund, under the rules and regulations adopted by the Board of Trustees of The Ohio State University, with the right to invest and reinvest as occasion dictates.

The annual income shall be used at the discretion of the dean of The Michael E. Moritz College of Law for supporting the Socio-Legal Center's annual operating needs.

It is the desire of the donor that this fund should benefit the University in perpetuity. If the need for this fund should cease to exist or so diminish as to provide unused income, then another use shall be designated by the Board of Trustees as recommended by the dean of the Moritz College of Law in order to carry out the desire of the donor.

Ohio Eminent Scholar in Macromolecular Structure and Function

The Ohio Eminent Scholar in Protein Engineering was established August 23, 1989, by the Board of Trustees of The Ohio State University with \$500,000 awarded by the General Assembly of Ohio and a matching \$500,000 from unrestricted gifts to the University. The name was revised on March 5, 2003.

The funds are to be invested in the University's permanent endowment fund, under the rules and regulations adopted by the Board of Trustees of The Ohio State University, with the right to invest and reinvest as occasion dictates.

The annual income shall be used to provide salary and program support for the work of an outstanding scholar-leader in protein engineering. Appointment as the Ohio Eminent Scholar in Macromolecular Structure and Function will be recommended by the dean of the College of Biological Sciences to the provost and president and approved by the Board of Trustees.

Should the need for this position cease to exist or so diminish as to provide unused income, then the income may be used for any purpose whatsoever as determined by the Board of Trustees, with preference being given to the recommendations from the appropriate administrative official of the University who is then directly responsible for education and research in biochemistry. Any redirection of this endowment prior to ten years from the date of established shall require the prior approval of the Ohio Board of Regents.

REPORT ON UNIVERSITY DEVELOPMENT (contd)

THE OHIO STATE UNIVERSITY FOUNDATION

Establishment of Named Endowed Funds

The Paul G. Althouse Endowment Fund

The Paul G. Althouse Endowment Fund was established on March 5, 2003, in accordance with the guidelines approved by the Board of Directors of The Ohio State University Foundation with gifts from Phyllis M. Althouse (B.S.H.E., 1954), family and friends in memory of Paul G. Althouse (B.S.Agr., 1953; M.S., 1963) and his 30-year career managing the meat lab, teaching meat science courses, and coaching The Ohio State University Meat Judging Team in the College of Food, Agricultural, and Environmental Sciences.

All gifts are to be invested by the Foundation, under the rules and regulations adopted by the Foundation's Board of Directors, with the right to invest and reinvest as occasion dictates.

The annual income shall be used to support the Department of Animal Sciences' Meat Judging Team in preparation for and/or in representing the University in regional and national intercollegiate contests and associated educational programs. Funds will be distributed by the department chair.

In any given year that the income is not fully expended, the unused portion should be reinvested in the principal.

It is the desire of the donors that this fund should benefit the University in perpetuity. If the need for this fund should cease to exist or so diminish as to provide unused income, then another use shall be designated by the Foundation Board in consultation with the vice president for Agricultural Administration and University Outreach, and executive dean for Food, Agricultural, and Environmental Sciences, and the chairperson of the Department of Animal Sciences, or their successors, in order to carry out the desire of the donors.

\$30,190.00

Fredrick Ives Chair's Scholarship Fund

The Fredrick Ives Chair's Scholarship Fund was established on March 5, 2003, in accordance with the guidelines approved by the Board of Directors of The Ohio State University Foundation with gifts provided by alumni and faculty of the Department of Food, Agricultural, and Biological Engineering in the College of Food, Agricultural, and Environmental Sciences.

All gifts are to be invested in the University Foundation, under the rules and regulations adopted by the Board of Trustees of The Ohio State University.

The annual income shall be used to provide undergraduate scholarships for students, selected by the Department chairperson or the chairperson's designee, who are majoring in programs of the Department of Food, Agricultural, and Biological Engineering in the College of Food, Agricultural, and Environmental Sciences or in the College of Engineering. Criteria for selection should include service to the Department and/or student and professional organizations.

It is the desire of the donors that this fund should benefit the University in perpetuity. If the need for this fund should cease to exist or so diminish as to provide unused income, then another use shall be designated by the Foundation Board in consultation with the vice president for Agricultural Administration and University Outreach, and executive dean for Food, Agricultural, and Environmental Sciences, and the chairperson of the Department of Food, Agricultural, and Biological Engineering, or their successors, in order to carry out the desire of the donors.

\$26,281.00

REPORT ON UNIVERSITY DEVELOPMENT (contd)

THE OHIO STATE UNIVERSITY FOUNDATION (contd)

Establishment of Named Endowed Funds (contd)

The Ruth and Jesse Owens Endowed Scholarship Fund

The Ruth and Jesse Owens Endowed Scholarship Fund was established on March 5, 2003, in accordance with the guidelines approved by the Board of Directors of The Ohio State University Foundation, with gifts from the Owens Family and The Jesse Owens Foundation.

All gifts are to be invested by the Foundation, under the rules and regulations adopted by the Foundation's Board of Directors, with the right to invest and reinvest as occasion dictates.

The annual income shall be used to support socio-economically disadvantaged students. Students must have financial need and must have participated in community service and leadership activities as a high school or college student. The awards shall be made in consultation with the University Committee on Student Financial Aid.

It is the desire of the donors that this fund should benefit the University in perpetuity. If the need for this fund should cease to exist or so diminish as to provide unused income, then another use shall be designated by the Foundation Board in consultation with the vice president for University Development and the director of Financial Aid in order to carry out the desire of the donors.

\$26,000.00

The David J. Ryan Scholarship Fund in Metals Casting

The David J. Ryan Scholarship Fund in Metals Casting was established on March 5, 2003, in accordance with the guidelines approved by the Board of Directors of The Ohio State University Foundation, with a gift from David J. Ryan of New Albany, Ohio.

All gifts are to be invested by the Foundation, under the rules and regulations adopted by the Foundation's Board of Directors, with the right to invest and reinvest as occasion dictates.

The annual income shall be used to provide need-based scholarships to College of Engineering students who are studying die casting. David J. Ryan Scholars will be eligible for renewal pending review of their academic progress. In the event there are no students studying die casting or die casting is no longer taught at the University, then industrial and systems engineering majors with demonstrated financial need will be considered. Selections will be made by the chairperson of the Department of Industrial, Welding, and Systems Engineering in consultation with the chairperson of the Department of Materials Science and Engineering and with a designated representative of the North American Die Casting Association and in cooperation with the University Committee on Student Financial Aid.

It is the desire of the donor that this fund should benefit the University in perpetuity. If the need for this fund should cease to exist or so diminish as to provide unused income, then another use shall be designated by the Foundation Board in consultation with the appropriate department chairperson in order to carry out the desire of the donor.

\$25,510.50

The R. Kirby Barrick Agricultural Education Fund

The R. Kirby Barrick Agricultural Education Fund was established on March 5, 2003, in accordance with the guidelines approved by the Board of Directors of The Ohio State University Foundation with gifts from Dr. R. Kirby Barrick, (B.S.Agr., 1970; M.S., 1973; Ph.D., 1980) of Champaign, Illinois. Dr. Barrick served on the faculty in the Department of Agricultural Education (1980-1996) and as department chair (1989-1996).

REPORT ON UNIVERSITY DEVELOPMENT (contd)

THE OHIO STATE UNIVERSITY FOUNDATION (contd)

Establishment of Named Endowed Funds (contd)

The R. Kirby Barrick Agricultural Education Fund (contd)

All gifts are to be invested by the Foundation, under the rules and regulations adopted by the Foundation's Board of Directors, with the right to invest and reinvest as occasion dictates.

The purpose of the fund is to support activities and programs related to teacher education in agriculture in the Department of Human and Community Resource Development in the College of Food, Agricultural, and Environmental Sciences.

The annual income may be used to support an annual symposium and/or similar activities to foster further development of agricultural teacher education, but should not be used for scholarship, fellowship, or assistantship support. In the event that the agricultural teacher education program ceases to exist within the College, the proceeds from the endowment should be used to promote teaching excellence in the College under the direction of the vice president for Agricultural Administration and University Outreach, and executive dean for Food, Agricultural, and Environmental Sciences or his/her designee. The endowment should be recognized as the sponsor of the activities.

It is the desire of the donor that this fund should benefit the University in perpetuity. If the need for this fund should cease to exist or so diminish as to provide unused income, then another use shall be designated by the Foundation Board in consultation with the vice president for Agricultural Administration and University Outreach, and executive dean for Food, Agricultural, and Environmental Sciences, in consultation with the chairperson of the Department of Human and Community Resource Development, or their successors, in order to carry out the desire of the donor.

\$25,043.00

The General Dynamics Land Systems Science and Engineering Scholarship Fund

The General Dynamics Land Systems Science and Engineering Scholarship Fund was established on March 5, 2003, in accordance with the guidelines approved by the Board of Directors of The Ohio State University Foundation, with a gift from General Dynamics Land Systems.

All gifts are to be invested by the Foundation, under the rules and regulations adopted by the Foundation's Board of Directors, with the right to invest and reinvest as occasion dictates.

The annual income shall be used to support a scholarship for students at The Ohio State University at Lima who are pursuing a degree in mechanical, electrical, industrial, or software engineering at The Ohio State University at Lima. The scholarship recipient(s) shall be selected in consultation with the Office of Student Financial Aid and be identified as having a high probability of graduating. The University will provide ongoing scholarship exposure and company recognition within the University and the community. The University will communicate with the engineering staff of General Dynamics Land Systems.

It is the desire of the donor that this fund should benefit The Ohio State University at Lima in perpetuity. If the need for this fund should cease to exist or so diminish as to provide unused income, then another use shall be designated by the Foundation Board in consultation with the appropriate college dean, school director, department chairperson, or program administrative officer in order to carry out the desire of the donor.

\$25,000.00

REPORT ON UNIVERSITY DEVELOPMENT (contd)

THE OHIO STATE UNIVERSITY FOUNDATION (contd)

Change in Description of Named Endowed Funds

The Bernard V. Fultz Family Scholarship Fund

The Bernard V. Fultz Family Scholarship Fund was established February 4, 2000, in accordance with the guidelines approved by the Board of Directors of The Ohio State University Foundation with gifts designated for support of The Michael E. Moritz College of Law, the College of Veterinary Medicine, and the College of Pharmacy from Bernard V. Fultz (J.D., 1955) of Pomeroy, Ohio; Barbara Fultz McManus (J.D., 1982) of Cincinnati, Ohio; Dr. Elizabeth Fultz Kellogg (D.V.M., 1980) of Worthington, Ohio; and Becky Fultz Parsons (B.S., 1982) of West Virginia. The description was revised on March 5, 2003.

All gifts are to be invested by the Foundation, under the rules and regulations adopted by the Foundation's Board of Directors, with the right to invest and reinvest as occasion dictates.

The annual income shall be used to provide scholarships in equal amounts to each student enrolled in the College of Law, the College of Veterinary Medicine, or the College of Pharmacy who is a graduate of a Meigs County high school. It is the intention that in each year if there is more than one qualified student who is a graduate of a Meigs County high school enrolled in any of the three colleges, that the income shall be used for scholarships for the total students in equal amounts enrolled in the colleges. Scholarships will be awarded in consultation with the University Committee on Student Financial Aid.

If there are no students in the College of Law, College of Veterinary Medicine, or College of Pharmacy who qualify for the scholarships for a period of five years, then in the sixth year and annually thereafter the income shall be used for scholarships for students who are graduates of a Meigs County high school enrolled in the College of Education with preference given to a student or students pursuing a Master's degree in elementary school administration, until a qualified student in the College of Law, College of Veterinary Medicine, or College of Pharmacy is enrolled at which time the scholarship will again be granted in accordance with the first priority uses for the funds.

In any given year that the income is not fully expended, the unused portion should be reinvested in the principal.

It is the desire of the donors that this fund should benefit the University in perpetuity. If the need for this fund should cease to exist or so diminish as to provide unused income, then another use shall be designated by the Foundation Board in consultation with the appropriate college deans in order to carry out the desire of the donors.

Mager Family Scholarship Fund

The Mager Family Scholarship Fund was established February 1, 2002, in accordance with the guidelines approved by the Board of Directors of The Ohio State University Foundation, with gifts from Richard D. Mager (B.S.I.E., 1972), Western Springs, Illinois, and other members of the Mager family. The description was revised on March 5, 2003.

All gifts are to be invested by the Foundation, under the rules and regulations adopted by the Foundation's Board of Directors, with the right to invest and reinvest as occasion dictates.

The annual income shall be used to support one or more scholarships for deserving undergraduates who are pursuing a Bachelor's degree in engineering. Preference will go to graduates of any Belmont County (Ohio) high school, with special preference to the St. John Central School. Recipients will be selected by the dean of the College of Engineering in consulta-

REPORT ON UNIVERSITY DEVELOPMENT (contd)

THE OHIO STATE UNIVERSITY FOUNDATION (contd)

Change in Description of Named Endowed Funds (contd)

Mager Family Scholarship Fund (contd)

tion with the University Committee on Student Financial Aid. All unused income will be added to principal by the end of each fiscal year.

It is the desire of the donors that this fund should benefit the University in perpetuity. If the need for this fund should cease to exist or so diminish as to provide unused income, then another use shall be designated by the Foundation Board in consultation with the appropriate college dean in order to carry out the desire of the donors.

Change in Name of Named Endowed Fund

The Greer Steel Company Athletic Football Scholarship Fund

The Billy Joe Armstrong Football Scholarship Fund was established April 6, 1999, in accordance with the guidelines approved by the Board of Directors of The Ohio State University Foundation, with gifts from the Greer Steel Company. The name was revised on March 5, 2003.

All gifts are to be invested by the Foundation, under the rules and regulations adopted by the Foundation's Board of Directors, with the right to invest and reinvest as occasion dictates.

The annual income shall be used to provide scholarship costs for a student athlete who is the starting center on the football team pursuing an undergraduate degree at The Ohio State University. The recipient shall be selected by the director of Athletics in consultation with the University Committee on Student Financial Aid.

It is the desire of the donor that this fund should benefit the University in perpetuity. If the need for this fund should cease to exist or so diminish as to provide unused income, then another use shall be designated by the Foundation Board as recommended by the director of Athletics in order to carry out the desire of the donor.

CAPITAL PROJECTS

Resolution No. 2003-99

REQUEST FOR CONSTRUCTION AUTHORIZATION

DREESE LAB RENOVATION – PHASE II

REPORT OF CONTRACTS AWARDED

HAGERTY HALL REHABILITATION

Synopsis: Authorization to enter into construction contracts for the Dreese Lab Renovation – Phase II project and the acceptance of the report of contracts awarded for the Hagerty Hall Rehabilitation project are requested.

WHEREAS at Dreese Lab the University desires to remove and replace the deteriorated stone tile facing from planter and retaining walls and replace the 8th floor canopy roof; and

WHEREAS the construction document project cost is \$210,000, with funding provided by House Bill 808; and

CAPITAL PROJECTS (contd)

WHEREAS a resolution adopted by the Board of Trustees on July 12, 2002 authorized the President and/or Senior Vice President for Business and Finance to request construction bids in accordance with established University procedures, and if satisfactory bids were received to award contracts for the following project:

(* Recommended alternates included in these amounts)

Hagerty Hall Rehabilitation

This project rehabilitates Hagerty Hall, including building system replacement and interior redesign of the spaces to house a portion of the College of Humanities. The total project cost is \$24,400,000; funding is provided by House Bill 850 (\$18,500,000), House Bill 748 (\$1,000,000), Central University funds (\$3,000,000), and gifts to the College of Humanities (\$1,900,000). The estimated completion date is March 2004. The contracts awarded are as follows:

Design:	Wandel & Schnell, Columbus, Ohio
General Contract:	Miles McClellan Construction, Columbus, Ohio
Amount:	\$8,364,000 *
Estimate:	\$10,008,995 *
Plumbing Contract:	Aggressive Mechanical, Columbus, Ohio
Amount:	\$1,139,000 +
Estimate:	\$916,099
HVAC Contract:	Farber Mechanical, Columbus, Ohio
Amount:	\$4,289,000 +
Estimate:	\$3,615,210
Electric Contract:	Gaylor Group, Inc., Dublin, Ohio
Amount:	\$2,232,611 *
Estimate:	\$2,537,466 *
Demolition Contract:	American Services Group, Cleves, Ohio
Amount:	\$740,000
Estimate:	\$787,356
Asbestos Abatement Contract:	Keen & Cross Environmental, Granville, Ohio
Amount:	\$227,937
Estimate:	\$419,835
Total All Contracts:	\$16,992,548
Contingency Allowance:	\$2,705,554
Total Project Cost:	\$24,400,000

+ The Plumbing and HVAC Contracts are in excess of the filed estimate of cost; however the total price of all contracts is within 10% of the total estimate of cost and is recommended for award as provided by Section 153.12 of the Revised Code.

NOW THEREFORE

BE IT RESOLVED, That the President and/or Senior Vice President for Business and Finance be authorized to enter into construction contracts, if satisfactory bids are received, for the Dreese Lab Renovation – Phase II project in accordance with established University and State of Ohio procedures, with all actions to be reported to this Board at the appropriate time; and

BE IT FURTHER RESOLVED, That pursuant to the actions previously authorized by the Board, the report of award of contracts and establishment of contingency funds for the Hagerty Hall Rehabilitation project is hereby accepted.

(See Appendix XXXVII for maps and background information, page 901.)

ADOPTION OF PRINCIPLES REGARDING UNIVERSITY LAND USE

Resolution No. 2003-100

Synopsis: Adoption of the proposed principles and process regarding development of University land is proposed.

WHEREAS in October 1995 the Board of Trustees adopted a University Master Plan to guide the physical development of the University's campuses and other locations and, since that time has adopted a number of district plans to provide for the more detailed planning for various areas of the Columbus Campus; and

WHEREAS the Board shares a concern that the University's land assets be used and developed in a manner that supports the Master Plan and the University's Academic Plan:

NOW THEREFORE

BE IT RESOLVED, That the Board of Trustees hereby adopts the proposed Principles and Process regarding Development of University Land and directs the University to incorporate these principles and process in the update to the University Master Plan to be presented to the Board for consideration in the coming year.

(See Appendix XXXVIII for background information, page 907.)

Upon motion of Ms. Longaberger, seconded by Mr. Sofia, the Board of Trustees adopted the foregoing resolutions by unanimous roll call vote, cast by Messrs. Patterson, Sofia, McFerson, Borrer, and Judge Duncan, Meses. Longaberger, Hendricks, and Davidson.

--0--

President Holbrook:

I would like to mention that the Report on University Development resolution includes the establishment of The Robert M. Duncan/Jones Day Designated Professorship in Law. Judge Duncan, we are very pleased for you and look forward to celebrating this at the luncheon given in your honor later today.

Mr. Patterson:

The Board of Trustees would also like to join President Holbrook in congratulating and recognizing Bob Duncan. I know of no one who commands and has earned more respect than Bob Duncan. I suppose if you could describe Bob, he is a true gentleman in the finest sense of the word. Bob, congratulations.

--0--

Thereupon the Board adjourned to meet Friday, April 4, 2003, at The Ohio State University Mansfield Campus, Mansfield, Ohio.

Attest:

David O. Frantz
Secretary

James F. Patterson
Chairman

**AUTHORIZATION FOR CAPITAL PROJECTS
SUMMARY**

<u>Project</u>	<u>Approved Amount</u>	<u>Funding Source</u>	<u>Requested Action</u>	
Hagerty Hall Renovation	\$24.4M	State University College	\$19.5M 3.0M 1.9M	Enter into construction contracts
Dreese Lab Renovation	\$0.2M	State	\$0.2M	Enter into construction contracts



Requesting Agency(s): HUMANITIES ADMINISTRATION

Location(s): HAGERTY HALL, JAMES E.

Gross Sq. Ft.131,506 Age: 1924

Description: Rehabilitate the entire building, including building system replacement and interior redesign of the spaces to house a portion of the College of Humanities.

Project Team:

Facility Planner: Teresa Yu
(yu.195@osu.edu)

Project Captain: Christine Lawson
(lawson.132@osu.edu)

Project Assistant: Mikki Reese
(reese.153@osu.edu)

Field Coordinator: Christine Lawson
(lawson.132@osu.edu)

Project Information:

Local administration granted as per the letter dated 7/22/99.

Original project budget of \$20,500,000 approved by the Board of Trustees on February 5, 1999. Project budget increased to reflect 2002 dollars and improved alignment of space to meet programmatic needs presented to and approved by the BoT on July 12, 2002

Source of Funds:	Original	Revised	Uses of Funds:	As Designed	As Bid	Completion
Centrally Funded Capital	\$0.00	\$3,000,000.00	Construction	\$17,077,770.00	\$16,992,548.00	\$0.00
Projects			Contingency	\$2,717,954.00	\$2,705,554.00	\$0.00
Development-Humanities	\$1,000,000.00	\$1,900,000.00	Design	\$1,781,533.00	\$1,781,533.00	\$0.00
HB748 Columbus Line	\$1,000,000.00	\$1,000,000.00	Equipment	\$2,506,183.00	\$2,506,183.00	\$0.00
Items			Percent for Art	\$185,000.00	\$185,000.00	\$0.00
HB850 Line Item	\$18,500,000.00	\$18,500,000.00	State Architect	\$50,000.00	\$50,000.00	\$0.00
Appropriation			University Administration	\$180,347.00	\$179,182.00	\$0.00
Total:	\$20,500,000.00	\$24,400,000.00	Total:	\$24,498,787.00	\$24,400,000.00	\$0.00



Schedule:	Projected	Revised	Actual
Planning			
Arch/Engr Approved by B/T (\$16,320,000 Project)	11/01/1996		11/01/1996
Bidding Approved B/T (\$20,500,000 Project)			02/05/1999
Bidding Approved B/T (\$24,400,000 Project)	09/01/1998	07/12/2002	07/12/2002
Design			
Arch/Engr Contract			03/06/2000
Schematic Design Approval	10/31/1997	09/30/2001	05/01/2001
Design Dev Document Approval	01/30/1998	12/20/2001	12/20/2001
Construction Document Approval	05/29/1998	08/12/2002	08/02/2002
Bidding			
Bid Opening (Demo/Asbestos Abatement)			08/08/2002
Bid Opening	10/01/1998	09/24/2002	09/24/2002
Construction			
Construction Start	12/01/1998	11/04/2002	10/21/2002
Report of Award to B/T (\$24,400,000 Project)	12/01/1998	03/07/2003	
Completion	12/31/1999	03/15/2004	
FF&E			
FF&E Design Dev Document Approval	02/28/2003		
FF&E Schematic Document Approval	03/29/2002		04/09/2002
FF&E Contract Document Approval	04/25/2003		
FF&E Final Quotes From Contracts	06/30/2003		
FF&E Purchasing	08/29/2003		
FF&E Funding Release	10/17/2003		
FF&E Purchase Order Issurance	11/17/2003		
FF&E Coord/Order Tracking	04/05/2004		
Close Out			
Occupancy	05/10/2004		

Hagerty Hall Rehabilitation

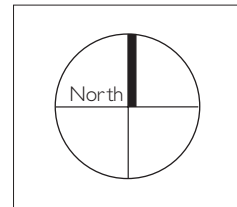
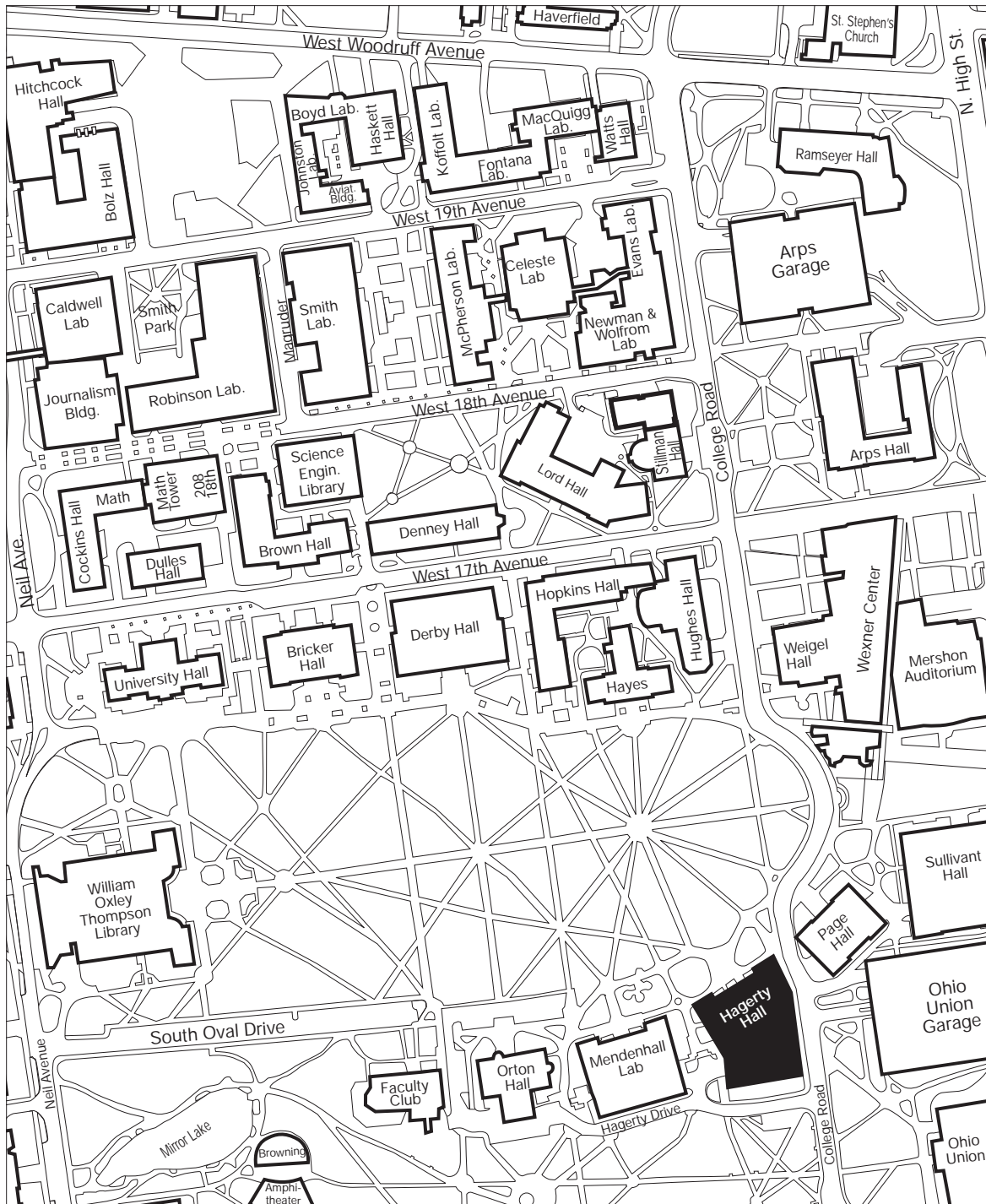

Office of Business and Finance
Office of Facilities Planning and Development

December 9, 2000



Requesting Agency(s): PHYSICAL FACILITIES

Location(s): DREESE LABORATORIES, ERWIN E.

Gross Sq. Ft. 186,567 Age: 1969

Description: Remove and replace the deteriorated stone tile facing from planter and retaining walls and replace the 8th floor canopy roof.

Project Team:

Facility Planner: Is Unassigned

Project Captain: Chuck Hamilton
(hamilton.6@osu.edu)

Project Assistant: Steve Deedrick
(deedrick.4@osu.edu)

Field Coordinator: Is Unassigned

Project Information:

Source of Funds:	Original	Revised	Uses of Funds:	As Designed	As Bid	Completion
HB808 Columbus Line	\$210,000.00	\$210,000.00	Total:			
Items						
Total:	\$210,000.00	\$210,000.00				

Schedule:	Projected	Revised	Actual
Planning			
Bidding Approved B/T (\$210,000 Project)	03/07/2003		

Dreese Lab Renovation - Phase II

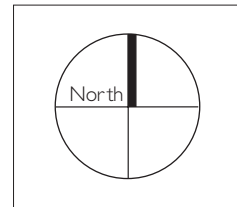
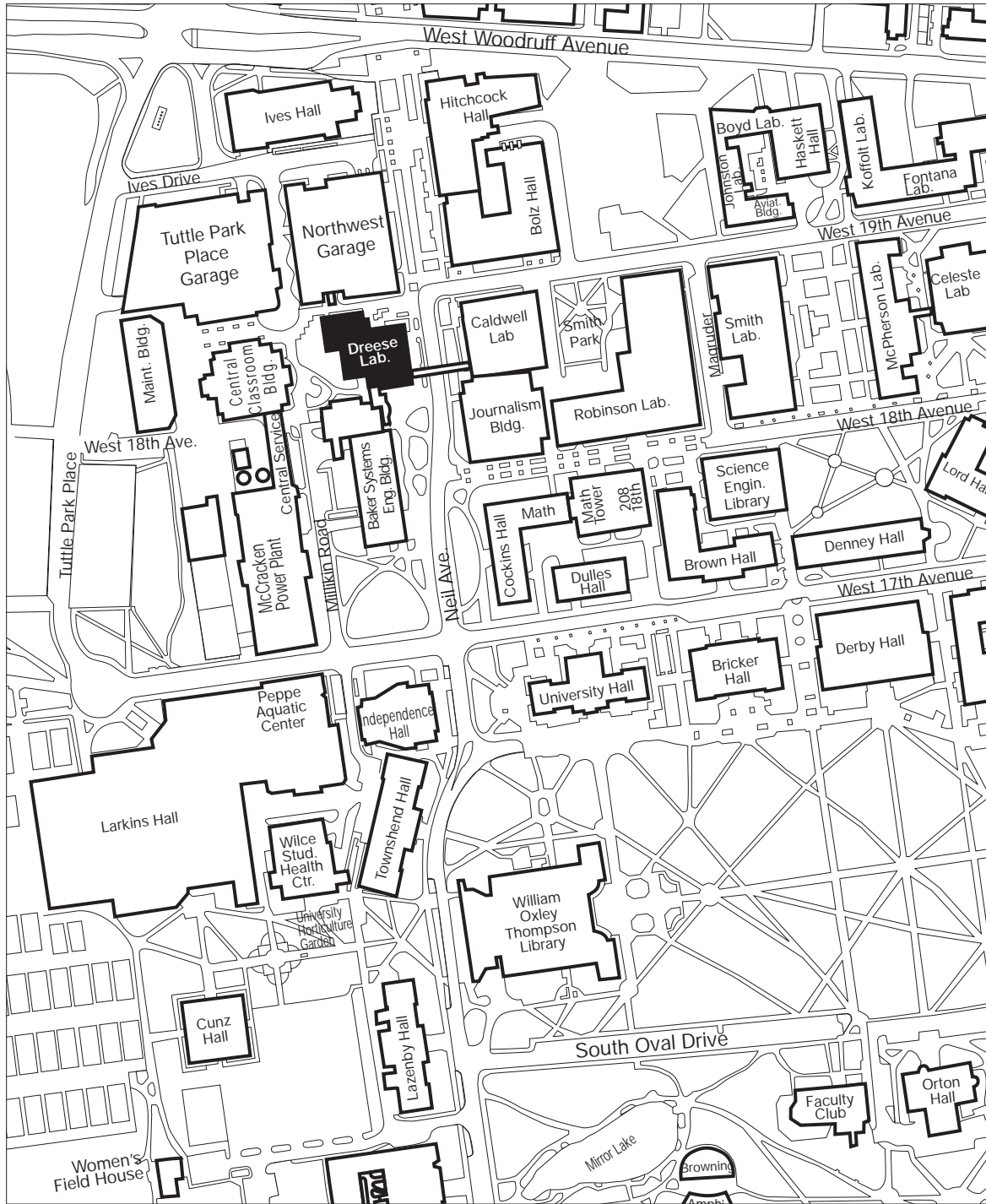

Office of Business and Finance
Office of Facilities Planning and Development

February 12, 2003

PRINCIPLES REGARDING DEVELOPMENT OF UNIVERSITY LAND

- Use of University land must fully support the mission of the University and the goals of the Academic Plan.
- Use of University land needs to respect the Master Plan's Long Range Principles:
 - management of growth;
 - conservation of land resources;
 - preservation of open space;
 - reinforcement of the Master Plan's concept of urban campus design for the Columbus Campus;
 - retention of the diversity of the campus environment; and
 - reinforcement of urban design of the vehicular circulation system.
- Unless specifically determined otherwise by the Board of Trustees, use of University land should be consistent with uses provided for in the Master Plan and applicable district plan.
- Land must be regarded as a University asset to be used pursuant to University (rather than just departmental or college) decision making.
- Use of land through private development must not interfere or compete with the academic mission or the academic setting of the campus.
- Preference is to be given to long-term lease of land, rather than sale, for private development. Any sale of University land needs to include whatever restrictions or requirements for subsequent use are deemed appropriate.
- Private development must be done in accordance with University design and architectural principles, with University right of review regarding site and architectural design.
- Private development must provide the University with a fair rate of return, in payment or services, for the use of the land.
- Land use reviews must take into consideration the local conditions that may vary from campus to campus.
- The University will strive for a uniform zoning classification for all University land on all campuses to ensure a uniform standard for land use decisions.
- Review of proposals must encompass the totality of a project, not just its size, and take into consideration that a project on the periphery of campus may have different impacts than a project in the middle of campus.
- Review of land use proposals must take into consideration agreements that the University might have with other entities (e.g., Campus Partners, SciTech, and technical colleges sharing University land) regarding use of University and related land.
- Agreements with other parties leasing or using University land must recognize the fiduciary and legal responsibilities of the University as steward for the public land involved.

PROCESS FOR DECISIONS REGARDING USE OF UNIVERSITY LAND

- Review of all proposals for use of University land is to be coordinated through the Office of Business and Finance, in consultation with the University area currently exercising jurisdiction over the land and all other affected parties.
- Review of proposals will lead to a recommendation to be submitted to the Coordinating Council.
- The review process needs to include a siting study for any use or facility proposed.
- Coordinating Council will determine if other process steps are needed or others should be consulted prior to making a recommendation to the President.
- The President shall determine what recommendation shall be made to the Board of Trustees.
- The Board of Trustees must approve, by resolution, all major capital projects for the University and the purchase or sale of real property. The Board's Fiscal Affairs Committee must review all long-term land leases (ten years or longer), and leases of shorter duration that might be especially significant or sensitive, and all easements over University property.
- When land use (University or private development) impacts the neighboring community, consideration should be provided for community input.
- Land use decision-making needs to encompass ethical considerations and the avoidance of conflicts of interest or the appearance of such conflicts.
- For private development of University land, the University will consider a process to solicit proposals unless the specific conditions dictate another approach.

THE OHIO STATE UNIVERSITY
OFFICIAL PROCEEDINGS OF THE
ONE THOUSAND THREE HUNDRED AND NINETY-SECOND MEETING
OF THE BOARD OF TRUSTEES

Columbus, Ohio, April 4, 2003

The Board of Trustees met at its regular monthly meeting on Friday, April 4, 2003, at The Ohio State University Mansfield Campus, Mansfield, Ohio, pursuant to adjournment.

**

**

**

Minutes of the last meeting were approved.

**

**

**

April 4, 2003 meeting, Board of Trustees

The Vice Chairman, Mr. Sofia, called the meeting of the Board of Trustees to order on April 4, 2003, at 10:40 a.m. He requested the Secretary to call the roll.

Present: Zuheir Sofia, Vice Chairman, Tami Longaberger, Daniel M. Slane, Robert M. Duncan, Karen L. Hendricks, Dimon R. McFerson, Jo Ann Davidson, Douglas G. Borrer, Joseph A. Shultz, and Paula A. Habib.

--0--

Mr. Sofia:

Good morning. I'd like to begin by expressing our appreciation to Dean John Riedl and his staff for their warm greetings and wonderful hospitality. We are delighted to be here.

As you will notice, I'm not Mr. Patterson. My very good friend and chairman, Jim Patterson, recently underwent heart bypass surgery. I'm pleased to announce that he is doing very well and will be back with us in a couple of weeks. In the meantime, we wish him well. Recently he received a wonderful get-well letter from President Bush, who wrote that he remembered very well the commencement speech he gave at Ohio State. Jim was very pleased with that.

Mr. Patterson at one time was the Board representative to the Mansfield Campus, so he has been here many times. John, he truly wanted to be here this morning, but his good nurse, Nancy, held him back. He said he did not want to miss this meeting, because he has fond memories of the Mansfield Campus. On his behalf, he wanted me to extend his appreciation and mention, again, how sorry he is that he couldn't be here today. He said he actually scheduled this whole meeting around his calendar.

On behalf of the Board, again, we are delighted to be on your campus this morning and we hope every time we visit a regional campus we learn something. Also, I'd like to point out that we truly are very grateful for all the dedication of our faculty and staff, as well as our students. These are difficult times and everyone seems to be doing his or her part. We are really pleased and would like to provide any support or guidance to help everyone achieve their goals.

--0--

PRESIDENT'S REPORT

President Karen A. Holbrook:

I want to say how happy I am to be back on the Mansfield Campus. Many of you know I toured all of the regional campuses this fall and said I would be back. I actually thought I would be back sooner, but I'm just glad to have this opportunity to be back here. These are such wonderful venues and I came away having learned so much about the regional campuses and having such a strong feeling for how important they are to our students. So it is a pleasure to be back.

I'm also very happy and pleased that this is the regional campus that we are on today because it gives us an opportunity to acknowledge the many contributions of Dean John Riedl – to Ohio State, to the Mansfield campus, and to the Mansfield community.

John joined Ohio State's Department of Mathematics in 1966 and he was the founding chair of the department's honors committee, an active member of the school math group, and a co-director of the calculator calculus project. He was also an assistant dean and associate dean for the College of Mathematical and Physical Sciences and served as its acting dean for two years.

PRESIDENT'S REPORT (contd)

President Holbrook: (contd)

But it was 16 years ago -- and my guess, John, is that you would not think that it was 16 years when you look back -- that he accepted both the responsibility and the privilege of becoming dean and director for the Ohio State Mansfield Campus and the coordinating dean for our four regional campuses. In these roles, he's forged close ties among the Ohio State campuses, pursued academic excellence and a student-friendly environment, and helped build the Mansfield Campus into a valuable resource for the community.

Through their many civic activities, both John and Mary have set personal examples of community leadership. It will clearly be a challenge and I'm looking at the person who will be challenged to follow Dean Riedl, but he leaves the program in excellent shape for a new leader to build upon. The University is very proud and very grateful for all that you and Mary have done, both for Ohio State and for this campus. I think we should acknowledge that now. Thank you.

It's then time to turn the next page and it gives me a great deal of pleasure to introduce Dr. Evelyn Freeman, who Provost Ray and I will be recommending to you to be appointed to the deanship and directorship of this campus. You will consider her appointment very shortly.

Dr. Freeman's been a faculty member at Ohio State since 1983 and has taught on the Mansfield, Marion, Newark, and Columbus Campuses. She is presently serving as director of the School of Teaching and Learning in the College of Education where she too has served as an associate dean. She is a respected scholar and teacher, and I know that the faculty, staff, and students at Mansfield and the community will all welcome her very warmly. I truly believe that we selected an outstanding leader and a very good fit for this campus. So allow me to introduce Dr. Evelyn Freeman, and you may want to say a few words.

Dr. Evelyn B. Freeman:

Thank you very much, Dr. Holbrook. I am quite honored that I will be appointed dean and director of The Ohio State University Mansfield Campus. I spent 13 very happy and very professionally rewarding years as a regional campus faculty member, so assuming a leadership role on a regional campus feels like a return to my academic roots. I also know that following in the footsteps of Dean Riedl sets expectations for this position very high. Dean Riedl has led Mansfield for 16 years with incredible dedication, vision, and integrity.

As the regional campuses embark on a new era with the implementation of the recommendations of the President's Commission on the Regional Campuses, the OSU Mansfield Strategic Plan, construction of a new building, and many other projects, I am very excited by the opportunities and the possibilities that are before us. I'm also very privileged to be able to work with the faculty, staff, students, trustees, and the community, as we lead OSU Mansfield into the future.

I'm deeply honored, and I want to thank you all for the confidence and trust that you have given me. Thank you.

President Holbrook:

On a final personnel issue, I think all of you know Dr. Brad Moore, who's been serving as our vice president for Research, has accepted a new position to become the vice president for Research at Northwestern University starting on May 1. Brad was not able to be with us today, but we will have an opportunity to

PRESIDENT'S REPORT (contd)

President Holbrook: (contd)

show him our appreciation for his leadership in this very important domain of the University in the very near future.

I'm now very pleased to introduce the individual we have selected to be the interim vice president for Research, Dr. Tom Rosol. Dr. Rosol is currently the senior associate vice president in the Office of Research and a very distinguished researcher in the College of Veterinary Medicine, where he has been a faculty member since 1986.

Tom is a diplomate of the American College of Veterinary Pathologists and the principal investigator, or co-investigator, of seven research programs at Ohio State University that total \$2.3 million in income. I'm not sure we can afford for him to be an administrator with that kind of great research success. But that means that he's very good, he knows what he's doing, and will serve us extremely well as we move our research mission forward. We will be asking you for approval of his appointment today. Tom, please stand so that we can all meet and welcome you. Thank you for coming.

The rest of my remarks today will address the topic of what I call the "tension" between access and excellence, an issue that is of vital concern to universities today as our citizens strive to enter college in greater and greater numbers. The topic is especially relevant to this meeting because of our presence on a regional campus, one of Ohio State's greatest assets to enhance access to higher education.

According to the recent publication, "Greater Expectations," and I quote, "The United States is fast approaching universal participation in higher education." There are several reasons why demands for access are intensifying across the nation and in Ohio. First, the number of high school graduates is expected to increase 20 percent by the year 2008. Ninety percent of high school seniors anticipate going on to college, and 75 percent of them will go on to some form of higher education within two years of their graduation.

The traditional student has also changed and no place feels that more than this campus, I'm certain. We're enrolling students from different racial, ethnic, and social groups of different ages, students who have different responsibilities compared with the traditional student of 20 years ago. Around 45 percent of today's students are older than 24 years of age and more women than men are enrolled in colleges.

Higher education, as you well know, is virtually a requirement for everyone in today's knowledge economy. The economic uncertainty drives students now into college rather than into a downturned job market. The world situation is prompting more students to stay closer to home than ever in the past, and our public universities are much more attractive than they've ever been because of the improved quality, the availability of merit- and need-based scholarship money, and the comparatively modest tuition.

Ohio State's Academic Plan sets forth a very ambitious agenda to enhance our academic quality. The six core strategies are designed to achieve the goals of excellence and a world-class reputation. As part of the implementation of this plan, we have already made admissions competitive in all four quarters on the Columbus Campus. Our entering class this past year was the best-qualified class we have ever had and, as we look toward the credentials of the entering class, they are still better yet.

PRESIDENT'S REPORT (contd)

President Holbrook: (contd)

As we continue to attract a stronger pool of better-qualified candidates for the Columbus Campus, we see that many of those who would have been admitted ten years ago and five years ago would not be admitted today. So there must be other venues for higher education that are available to them, especially for an Ohio State education.

Decisions about access are not ours alone to make. It's been asserted that in fact no other enterprise is as highly regulated as higher education. Thoughtful and knowledgeable members of our academy make decisions about access in collaboration with our governing boards. But others drive factors and policies that are out of our control and imposed by accrediting agencies, legislatures, and governors. In some instances, decisions about the factors that affect access directly or indirectly are also made at the federal level even through law. Moreover, regulation of education by outside groups is often mandated without new resources to effect the changes.

Beyond the barrier of competitive admissions, public universities must address other barriers to access. One is admissibility. We might like to believe that individual institutions set their own standards for admission. But the Michigan cases have shown us that some factors are well beyond our control. Admissibility is also affected by citizenship because international students today find it increasingly difficult to obtain visas to allow them to study in the United States, and then support for them, once here, is continually under siege locally.

A second barrier to access is inadequate preparation in our high schools. Universities share some responsibility for this barrier because we prepare the teachers who prepare the students. At Ohio State we're addressing this through our P-12 project and our University Education Council, as well as through numerous outreach programs designed to help improve Ohio's public schools, particularly those serving children of low-income families.

The Governor's Commission on Teaching Success in Ohio, which has recently completed its work, has provided 15 recommendations to promote quality teaching, school leadership, and student success. Our charge is to how to effect those recommendations and be part of making those changes to improve high school education.

Universities also have outreach programs that connect students from disadvantaged backgrounds with the universities through university-sponsored programs that are organized in their own schools and on university campuses. Such programs also help students realize that college is a realistic path, and it helps them reduce their feelings of intimidation about attending college and encourages them to pursue college preparatory curriculum in high school.

The third barrier is affordability. At Ohio State, appropriations for higher education have been cut more than \$303 million over the last three years. This is an amount that translates to a decrease of \$1,000 per student. In the last two years, appropriations have declined precipitously in two-thirds of our states as a result of deficits in revenues and excess spending, and 42 states are presently facing budget cuts to higher education.

In part to cope with these cuts, public universities raised tuition an average of 9.1 percent this past year. When Ohio State raised its tuition in the past year, the first item we funded from the tuition increase was \$3 million in financial aid to cover every cent of the increase above the standard Ohio 6 percent tuition increase. We made a commitment at Ohio State that no academically eligible

PRESIDENT'S REPORT (contd)

President Holbrook: (contd)

student should be turned away for financial reasons. This becomes increasingly challenging as federal and state governments have also cut back on the support for student financial aid and there is a greater reliance on what is done locally.

Although public universities no longer offer universal access, and Ohio State certainly doesn't as it once did, there are several alternate avenues that connect students to higher education and, specifically, to our public research universities. The Ohio State regional campuses play a critical role in helping us preserve access, which is persuasively documented in the report of the Presidential Commission on Regional Campuses. That report sets the stage for continued development of the strengths of our regional campuses.

Many of the people instrumental in producing that report are here today and I want to acknowledge the outstanding contributions of our trustee, Karen Hendricks; Vice President Bobby Moser, who was intending to be with us and is in France instead; Dean John Riedl; and Vice Provost Randy Smith. Thank you for making such an important statement about the value and relevance of these campuses.

Students who want an Ohio State degree may enroll at one of the four regional campuses, which offer enrollment. They can accumulate the credits, the grades needed to move on to Columbus or they may choose, as many of them do, to spend all four years on a regional campus and earn a bachelor's degree from Ohio State in business, education, English, history, or psychology. Here at Ohio State Mansfield, students can also work towards master's degrees in education and social work.

The regional campuses offer small class size in the small-college, student-friendly environment that many find conducive to success. And tuition on our regional campuses is nearly a third lower than it is in Columbus. The increased availability of on-campus housing will make our regional campuses accessible to traditional students from all over the state and, I might add, from other states as we begin to make these more destination campuses.

One of the great benefits of the regional campuses is that they also provide a very valuable and appropriate venue for the non-traditional, often place-bound student who has other life responsibilities, and they have numerous distance educational offerings.

Community colleges offer another alternate route to higher education and to public research universities and, like the regional campuses they attract and provide initial access to a large number of students through open admissions and lower tuition. The Ohio Board of Regents allocates over \$57 million in Access Challenge grants to keep the tuition low at our regional campuses, community colleges, technical schools, and those four-year colleges that offer access to larger percentages of minority students.

We, like a number of other public universities, have articulation agreements with community colleges throughout the state to facilitate a smooth transition from the community colleges to Ohio State. Sixteen two-year institutions, for example, offer preparatory programs toward an Ohio State degree in an agricultural science.

As the 1999 Kellogg Commission Report on the Future of the State and Land-Grant Universities stressed, and I quote, "Access to, through, and from" the university is what matters. Our regional campuses offer students access to the

PRESIDENT'S REPORT (contd)

President Holbrook: (contd)

excellence of an Ohio State education in a supporting setting that helps many of them succeed. The connection between Columbus and the regional campuses and our relationships with community colleges provide opportunity for students who are successful in those venues and decide to make the move to obtain access to the benefits of a Research One university and the many academic programs available on campus.

While we work to fulfill the goal of academic excellence articulated in the Academic Plan, we must continue to ensure that access is linked to higher education and to excellence for the citizens of Ohio. Thank you.

--0--

STUDENT RECOGNITION AWARD

Ms. Habib:

The Student Recognition Award is presented each month by the Board of Trustees to a student in honor of the student's achievement in his or her area of study, service to the University and/or community, and/or research achievements that have been a credit to the college and the University. This month's recipient is Marianne F. Williamson, who was nominated by Dean Riedl of The Ohio State University Mansfield Campus.

Mrs. Williamson is a 38-year-old wife and mother of two. She has been attending The Ohio State University for almost three years after a 17-year hiatus from academia to work and raise a family. Her goal at OSU is first to earn a bachelor's degree in middle childhood education and then a master's degree in education.

Marianne currently maintains a 3.86 GPA in the honors program at The Ohio State University. She has been on the Dean's List since returning to school in 2000 and has been a recipient of several awards and scholarships, including the Boy Scouts Harding Area District Award, for dedication and service to youth; the American Association of University Women's Scholarship; Grace High Washburn Trust Scholarship; the Mansfield Campus Scholarship; the Talbot's Women's Scholarship; the Someone Cares Scholarship; and the President's Salute to Undergraduate Academic Achievement.

Returning to college after so many years has been a wonderful, exciting, and certainly educational experience for Marianne. Many times she has felt like a child again, so eager to learn and know all there is to know about a subject. The more she learns, the more she wants to learn. When Marianne becomes a teacher she will use these recent experiences to understand her students' needs, striving to instill that same desire by creating an atmosphere conducive to learning. Mrs. Williamson believes The Ohio State University can give her the educational foundation she needs to become a great teacher.

Marianne has been active in homemaking and parenting, taking on long-term leadership roles in Boy Scouts, Girl Scouts, and PTO, and volunteering for church, school, fine arts, and literacy programs. Being a parent helps her to know firsthand how important a good education is for a child to succeed. Mrs. Williamson has also worked as a volunteer notetaker for the Conard Learning Center, a geological sciences lab assistant, and an OSU Mansfield Buckeye Ambassador.

STUDENT RECOGNITION AWARD (contd)

Ms. Habib: (contd)

Prior to raising a family, Marianne worked for six years in radio broadcasting, working her way up from disk jockey to news director in a small market Class A radio station. For a brief period, she worked as an administrative assistant in the human resources department in a factory. There she served primarily as a liaison between the employees and administration, concentrating on opening the lines of communication to improve production and morale. These experiences will also play an important role in her teaching ability, as she has learned the importance of accurate and effective communication.

Being a student myself, it is a great honor for me to be able to present a student like Marianne Williamson to the Board of Trustees. The Board appreciates the chance to meet students, especially ones who exemplify exactly how bright and committed the students at Ohio State really are.

Congratulations, Marianne.

Mr. Sofia:

Congratulations, again, Marianne. It's wonderful to be able to give such recognition to an exceptional student. You've had more careers than most of us!

--0--

MANSFIELD CAMPUS PRESENTATION

Dean John O. Riedl: [PowerPoint Presentation]

I'd like to go over a brief history of the Mansfield campus – where we've come from, where we are now, and where we are going in support of the Academic Plan.

In 1960 Ohio State Mansfield first began offering courses in the local high school. The local citizens struck a deal with Governor Rhodes. He said, "If you get the land, I'll build you a building." The citizens produced 650 acres, and Governor Rhodes, true to his promise, produced a building, which opened nine months after I came to Ohio State.

A technical college, which had pre-existed – it was in downtown Mansfield – was invited to join Ohio State on the campus in 1969. This is a separate institution with its own governance, budgets, and curriculum. We share facilities and a number of services. The services that we share allow us to give better services and better facilities to the students than either of us could operating alone. It's also more economical to work together.

You will notice the enrollment in the first five years were years when we were in the high school; and the sudden jump in enrollment when Ovalwood Hall was opened. Then you will see the little spike three years later when North Central came to the campus drew a few enrollments away from Ohio State, but there wasn't a serious blip. Then in 1986 -- when I came to the campus – you see that little dip there.

Taking a look at the FTE enrollment over the last 16 years, you can see it has risen by 50 percent. This year will be an all-time record. The minority enrollment -- which has been a focus of this campus since I came here -- has approximately tripled in the last 16 years. There's still a way to go, though. My estimate is that

MANSFIELD CAMPUS PRESENTATION (contd)

Dean Riedl: (contd)

it should grow another 50 percent before we reflect the population of the area that we serve.

A board of trustees was established in 1994, which has greatly helped us in the community. Members of the board will be introduced at the luncheon later, but many of the members are with us today. They've helped us with budgets, facility planning, monitoring community needs, and long-term planning.

One of the things that the board advocated was student housing. In 1995 we hired a private developer to build student housing immediately adjacent to the campus. In 2000 the developer expanded the number of units and expanded, again, this past fall to have a total of 190 units. The student housing attracts students mostly from northeast Ohio, but from as far away as California.

We emphasize that academically we are The Ohio State University. We offer Ohio State courses and maintain Ohio State standards. I took a close look at three years worth of data of students who started here and then moved to Columbus. The grade point average of that group in their last quarter here was 2.8, and their grade point average in their first quarter in Columbus was 2.8. The grade point average of a comparable group of students, juniors who had begun on the Columbus campus, was 2.8. So we feel that we are fairly successful in maintaining Ohio State University standards.

Financially, we are on our own. The money that is brought in from our teaching, tuition, and subsidy we spend. One exception is that we pay a service charge of 7.94 percent to the Columbus Campus.

Our faculty consists of 44 full-time, tenure-tracked faculty. We have three tenured administrators who teach part-time and 50 auxiliary faculty, most of them teaching part-time. Our faculty have Ph.D. degrees from Big Ten universities and from some fine universities throughout the country. On this slide, the universities with multiple representation are listed. You will notice that the University of Florida has sent us three faculty -- they come here for the climate!

We have 211 sections of 132 different courses offered, spanning 42 different departments. You see there are almost as many departments as we have faculty and several faculty teach in more than one department.

OSU degrees can be earned here. Students can take all of the courses for The Ohio State University degree in elementary education and that has been true since 1968 -- two years after we opened this campus. Since 1990, we opened up the possibility of degrees in psychology and English. Then in 2000, we started offering degrees in history and business, which is done mostly by distance learning. The Fisher College of Business will be graduating its first students this year.

The M.Ed. degree in elementary education carries the licensure for teachers on the regional campuses, as it does in Columbus. Then we have a Master of Arts degree in education, which is for people who are already teaching and wish to complete their credentials. A Master of Social Work degree is available mostly on this campus, but students do take some of those courses in that program on the Columbus Campus.

Ohio State maintains its land-grant tradition of open access, as President Holbrook mentioned, through the regional campuses. We serve a lot of students who are location-bound students -- such as Marianne who was honored today.

MANSFIELD CAMPUS PRESENTATION (contd)

Dean Riedl: (contd)

These students cannot pick up and leave their children behind and go live in a dorm in Columbus. Other students come to us for financial reasons.

Some students cannot meet the tougher academic standards of the Columbus campus. Those students do not lower the average quality of regional campus students. We've been monitoring that fairly closely. As the Columbus ACTs have moved up, the regional campus ACTs have not gone down; they have stayed even. The students who do not meet the tougher standards are still pretty good students. They're every bit as good as the students we've attracted traditionally. The last one is the Agricultural Technical Institute and that serves a different mission. It's a two-year technical institute.

We pride ourselves on being student-friendly. Many students come to us precisely because they choose to begin their Ohio State education in a small college atmosphere where the emphasis is on undergraduate teaching. We value undergraduate teaching, we recruit teachers for it, we help them develop their teaching here, we reward it, and we get it. The student evaluations are higher here than they are on the OSU average. The gray bars are the OSU Mansfield averages on all of the 10 items in the standard SEI, and year after year we find a pattern such as this one -- the year 2000.

Tuition historically was close to the Columbus Campus -- if you look at the bar to the left. The gap widened with Access Challenge. That little hollow bar on the top is part of the tuition the student doesn't pay. That is defrayed by the Access Challenge grants. So what the student actually pays you see on the extreme right. As President Holbrook indicated, a freshman on the Columbus Campus would pay the amount in the left. A freshman on the Mansfield Campus would pay -- the green bar -- about one-third less.

I'd like to give you a brief history of the technology. In 1974 my predecessor was asked to survey the technology needs of the faculty, and his conclusion was that they needed to produce one more electronic calculator to add to the one that they already had. Sixteen years later, a little bit after I came, we had a study of the campus. They said then that our computerization was about two-thirds complete, because by then 13 faculty had computers and 10 others shared them. If you added that up, that was 13, plus half of 10, that would be 18 computers, so they figured we should have been aiming for 27 computers. Two years prior there were only two computers, so that did represent progress.

As of yesterday, we have 496 computers; all of the faculty and most staff have them. We have eight teaching labs, which have just under 200 computers available to students. That's a ratio of one computer for every eight students. In addition, all of the rooms in the Campus Village Apartments are connected to the network, and all of our computers are networked to the Columbus resources and to the web. So there's been dramatic growth in that area.

We have four different areas of outreach and engagement that I'll briefly touch on. Individual initiatives are probably the most important and we do place work-study students in the community. We have some organized initiatives for schools and then a new Center for Corporate and Community Education.

Among the individual community services, I'll just mention two: Gary Kennedy is the founding chairman of Richland County's University College Access Network. This agency tries to find ways to encourage high school students to raise their aspirations and go on to college. Terri Fisher was the principle author of the

MANSFIELD CAMPUS PRESENTATION (contd)

Dean Riedl: (contd)

Community Needs Assessment, which was made possible by the United Way of Richland County and several other organizations. So these are different ways our faculty and staff serve the community.

This year we have placed work-study students in 42 different community and governmental agencies. I'll mention just two examples: 1) Katie Ritchie, a criminology major, works in the Bureau of Workers' Compensation and assists the Bureau with investigations for criminal and civil cases; and 2) John Bump, a pre-law student, works in the Mansfield City Law Director's office and assists them by researching and preparing subpoenas.

These positions offer valuable service to the community, give tremendously valuable experience to our students in real honest-to-gosh job settings, and helps enhance the University's reputation among the community. About 40 percent of our work-study students are in community placements.

For schools, we have M.A. courses for teachers and have had fairly decent enrollment. We have exchange of services agreements with 20 different schools, which help defray the costs of the teachers taking courses at Ohio State. We have a Mid-Ohio Writing Center; it's one of only four in the State of Ohio. And we have a teachers academy, which focuses on math, science, and using technology in the teaching of math and science.

The Center for Corporate and Community Education began five years ago. The center provides work force training to businesses and industries in this area and also receives a lot of grants and grants can pay up to half of the training costs. They have served about 80 different businesses and have eight programs going as we speak.

On plans for the future, you heard this morning about the President's Commission on Regional Campuses and the curricular plans that are the consequence of that commission report. We have a Mansfield Campus Master Plan, which, I hope, you will be approving later this morning and we have plans for a new building. The President's Commission is anticipating more student housing, and selective admissions will produce fewer and better freshman on the Columbus Campus and rely on regional campuses to maintain the open admissions tradition.

As some of you heard this morning, the selective admissions is working. We have an admissions program now that asks students to state their first and second choice of campuses. So instead of rejecting them and then trying to retrieve them, we tell them from the start to state their first and second choices. The result here is that, to date, our number of new freshman applications has gone up 60 percent over last year. The number of admissions and fee payments is actually up 80 percent. I'm not anticipating that type of growth, but they are clear indications that this new admissions scheme is working.

As enrollment grows and more student housing is added, we will add faculty and staff to match the growth. This will make it possible to add a limited number of degree programs if we can get a critical mass of faculty in certain areas. We also want to put in some minor programs. I think these minor programs are likely to happen rather quickly. The business program we plan to get in next year will be in the form of distance learning delivered from the Fisher College of Business.

The Mansfield Campus Master Plan has been developed over the past two years in full cooperation with North Central State College. It's one that you had the first

MANSFIELD CAMPUS PRESENTATION (contd)

Dean Riedl: (contd)

reading of last month and, I hope, will be approved today, so I won't go into that any further.

Finally, we are planning to build a new building to prepare for more students. This last week we selected the architect, we still haven't negotiated the price with them, but we think that will happen soon. This building should open a year from this fall if everything goes on schedule.

After that is done, we're planning as Phase II, a thorough renovation of Ovalwood Hall. We have been pretty good in maintaining the facilities we have. We've made this a rather high priority to keep the deferred maintenance list down to a reasonable, manageable amount. We have some projects that we aren't doing now, but we have a plan for dealing with them over the next couple of years.

This is a quick overview of where we've been, where we are now, and where we plan to go. If there are any questions, I'd be happy to attempt to answer them.

Mr. Sofia:

Any questions? This was a wonderful presentation and very impressive of what you have done here, so congratulations, Dean Riedl.

Dean Riedl:

Thank you.

--0--

COMPENSATION BENCHMARKS

Provost Edward J. Ray:

At this point, I'd like to call on Barbara Snyder, vice provost in the Office of Academic Affairs, and who is currently serving as interim vice president for University Relations; Larry Lewellen, associate vice president for Human Resources; and J Henderson, director of Compensation in the Office of Human Resources, to provide a status report on our compensation relative to benchmarks.

Ms. Barbara R. Snyder: [PowerPoint Presentation]

Larry, J, and I will be talking about four things: 1) the five-year history of salary increases compared to our benchmark institutions, 2) our current average salaries compared to our benchmark institutions, 3) how we're investing our salary dollars, and 4) how our benefits costs compare to our benchmark institutions.

If you look at the second slide, you will see the five-year history of raises compared to our public benchmarks. Each column is one of the benchmark institutions and each segment is a year, starting at the bottom, which represents the 1998-99 academic year. So you can see in this five-year period that we are 8th out of 10. All of the benchmarks ahead of us, the top seven, had at least two years of raises that were five percent or greater and those are indicated by the blue segments. If we showed you our 10-year history for salary increases, you would see that we were 9th out of 10. So we feel like we're not where we would like to be.

COMPENSATION BENCHMARKS (contd)

Ms. Snyder: (contd)

The next slide shows you our average salaries compared to our benchmarks. Five years ago, we were 2.1 percent below market, and we were 6th out of 10. Seven years ago, we were actually slightly above the average for benchmarks. So we've been slipping. In the current year, you can see that we are 8th out of 10 in terms of average salary, just as we are in average increases, and we're now 4.4 percent below the benchmark average. This actually is progress, because last year we were just over 6 percent below the benchmarks. So we made a little bit of progress with the increases we were able to give last year.

The next slide shows you where we have been and where we're headed. When you compare us to the Association of American Universities -- the 60 premier doctoral-granting research institutions -- twenty years ago we were actually in the top quarter of AAU institutions when you compared our salaries to theirs. As you can see: 15 years ago we had dropped to about the top third, 10 years ago we were just below half, 5 years ago we were at the bottom third, and now we are almost at the bottom fourth among AAU institutions. We are 46th out of 60. This is not where we would like to be. As the President has said, when your salaries look like that, you become a target for being raided by other institutions and we don't want to lose our best faculty to other places.

I'm going to let Larry continue and talk about staff salaries.

Mr. Larry M. Lewellen:

If you'll move on to the next slide that talks about staff salaries compared to external markets -- I'm featuring the work here of J Stephen Henderson. J previously headed up compensation for Nestles U.S.A. and Raytheon Aircraft Division. He joined us recently and has done a lot of work for us in compensation redesign for staff, which is very market and performance-focused. So this reflects a lot of work that he and the colleges have done over the past year to match staff positions to market. Over 85 percent of our staff are in positions that are directly matched to external market positions.

You can see that the red bars are where our staff are below the market. You can see the extent to which some of our occupational groups -- because there are so many staff positions to make it easier, we combined them into occupational groups to look at -- are challenged against the market here by the areas represented by the red bars.

The clerical/secretarial area is one that looks like it is above market, but it's one of our areas where we have the longest service staff. This tends to be the case where we have a lot of senior staff who are paid well, and we have quite a few staff who have been hired in recent years who are still very challenged against their market. So we can't just generalize that group; we have to realize that is due more to seniority than anything else. We're also glad that many departments value their clerical and office staff to this degree.

On the next slide, another look at staff salaries is comparing OSU -- the scarlet bar -- against the State of Ohio -- the blue bar. We're different than the State of Ohio state government. Yet it is an important market for us to compare against and we typically have been asked by the trustees to provide a slide to show where our positions are. In this case, this is a cross-section of positions since a university and a state government are different. You can see many of our positions are paid below the state government of Ohio. We're challenged to catch up with them, as well as with the rest of our markets. There are a few cases here where we're fortunate to be above, but overall our staff are paid

COMPENSATION BENCHMARKS (contd)

Mr. Lewellen: (contd)

around 8-10 percent below the state government of Ohio. It's another market we need to be aware of and try to catch up with.

Looking at graduate associates, this information is from Autumn 2001. We thought it was important to share it again, to keep us focused on graduate associates as well as faculty and staff. This is examining what we call, "Net Financial Support of Graduate Associates," against our group of benchmark peers and the other public institutions in the CIC. Among 14 institutions, you can see we rank 13th out of 14, not on the positive end, but the lower end.

The net financial support comes from adding the stipends that we provide for them -- what we support and what we provide for health care -- subtract from that any fees they need to pay for health care or that they need to pay for course work. Some institutions require you to pay nothing for course work when you're a GA or some require you to pay some or quite a bit. To level all this out, we just add up all the support and subtract all the fees. When you do that, we're challenged there more so because of support of health care. Although we are on a plan that the provost and president implemented a few years ago to ramp up support for health care graduate associates, we're still moving that forward and pleased to be doing that. You can see we need to do that.

As Barbara mentioned, one of our topics was how are we investing our dollars. We've looked at many slices of that in the past, but we wanted to highlight one here, which is, "How are we investing our raises this past year -- the year that we're in -- by gender and ethnicity?" You can see on the top slide how men and women compare for the raise packages in aggregate by these occupational groups: faculty, unclassified, and classified staff; and for minority and non-minority faculty and staff at the bottom. We're really pleased and happy to report that our deans, chairs, vice presidents, and others are doing a wonderful job of investing very consistently and evenly across race and gender lines.

The last topic is to look at benefits costs, because benefits are such a challenge nationally. We want to make sure that we keep our costs in line with other institutions. The last two or three years we have provided this data to the Board. You will notice this slide shows the 60 AAU institutions and a number of them participate in a data exchange group where we exchange data on cost, the number of items, and benefits designs. We know we've experienced some heavy increases in benefits costs, but we're still, on a per faculty or staff basis, about in the middle of that group. I'm always surprised when I see the health care cost of some of that group, and we're pleased to be able to provide the packages that we have at sort of a mid-level cost.

Yes, Mr. McFerson?

Mr. McFerson:

Benefits can be all kinds of things. Is this just health care or does it include tuition reimbursement or any form of retirement? Give me an idea of what is included in "benefits."

Mr. Lewellen:

That's an excellent point. There are two benefits charts here. This chart looks at health care and the next chart that we'll look at -- benefits as a percent of salary -- is all of our benefits costs. It is true here we are just looking at health care. If

COMPENSATION BENCHMARKS (contd)

Mr. Lewellen: (contd)

you'd like us to expand that next year to include all benefits, we'd be glad to do that.

Mr. McFerson:

I just wanted to understand what I was looking at.

Mr. Lewellen:

I wish we could supply all benefits for \$3,800 a year, but we can't do that.

The last slide shows how our benefits expenditures look as a percent of total compensation. Another question the Board has asked in the past, is for us to track to make sure that our benefits as a portion of our compensation doesn't get out of whack. You can see we're tracking around 18 percent right now, which is similar to where we were in the early 1990s. We've gone down from that and back up to that, so it's stayed fairly consistent. So we don't think that part is out of control.

To summarize, you can see our faculty and staff salaries are behind all the markets that we track, whether it's our benchmark institutions, AAU, the broad staff markets, or the state government of Ohio. The same is true for our graduate associates; we're challenged there to track against the market. Our benefits costs, though they've been high, are competitive and, hopefully, compare reasonably with other institutions.

This report really is just for the purpose of letting you know where we are against our competitive markets and institutions. We do not have at this time any recommendations for what we would do next year for salaries. It's too early for that in this budget environment. So this is just background information as we do budget planning for the University.

We'd be glad to entertain any questions.

Mr. Sofia:

Thank you, Larry, Barbara, and J. Any questions? We appreciate the presentation and I think that the Trustees are going to be very supportive to make sure that Ohio State stays competitive. Thank you.

Ms. Snyder:

We appreciate that. Thank you.

Mr. Lewellen:

We're glad to hear that.

(See Appendix XL for background information, page 971.)

--0--

CONSENT AGENDA

President Karen A. Holbrook:

We have nine resolutions on the Consent Agenda today as follows:

PERSONNEL ACTIONS

Resolution No. 2003-101

BE IT RESOLVED, That the personnel actions as recorded in the Personnel Budget Records of the University since the March 5, 2003 meeting of the Board, including the following Appointments, Appointment/Reappointments of Director/Chairpersons, Leave of Absence Without Salary, Professional Improvement Leaves, and Emeritus Titles as detailed in the University Budget be approved.

Appointments

Name: EVELYN B. FREEMAN
Titles: Dean and Director/Professor
Regional Campus/School: The Ohio State University-Mansfield/Teaching and Learning
Term: August 1, 2003, through June 30, 2008
Present Position: Director and Professor, School of Teaching and Learning

Name: DALE A. OESTERLE
Title: Professor (The J. Gilbert Reese Chair in Contract Law)
College: Moritz College of Law
Effective: August 16, 2003
Present Position: Monfort Professor and Director of the Center for Entrepreneurial Law, School of Law, University of Colorado at Boulder, Boulder, CO

Name: THOMAS J. ROSOL
Title: Interim Vice President
Office: Research
Effective: May 1, 2003
Present Positions: Senior Associate Vice President, Office of Research and Professor, Department of Veterinary Biosciences

Name: JOHN R. SNYDER
Titles: Dean and Director/Professor
Regional Campus/School: The Ohio State University-Lima/Allied Medical Professions
Term: July 1, 2003, through June 30, 2008
Present Position: Dean, School of Allied Health Professions, and Professor, Clinical Laboratory Services, Louisiana State University Health Sciences Center, New Orleans, LA

Appointment of Director

July 1, 2003, through June 30, 2007

Center for Medieval and Renaissance
Studies

Barbara A. Hanawalt

Reappointment of Chairpersons and Director

January 1, 2003, through June 30, 2006

Emergency Medicine
Molecular Virology, Immunology and
Medical Genetics

Douglas A. Rund

Caroline C. Whitacre

PERSONNEL ACTIONS (contd)

Reappointment of Chairpersons and Director (contd)

January 1, 2003, through June 30, 2006 (contd)

Physical Medicine and Rehabilitation

William S. Pease

July 1, 2003, through June 30, 2004

Multicultural Center

Christine Ballengee Morris*

*Interim

Leave of Absence Without Salary

HANI J. DOSS, Professor, Department of Statistics, effective Autumn Quarter 2003, to accept a visiting professorship at Yale University.

Professional Improvement Leaves

L. S. FAN, Distinguished University Professor and Chair, Department of Chemical Engineering, effective Autumn Quarter 2003, Winter Quarter and Spring Quarter 2004.

STUART H. ZWEBEN, Professor and Chair, Department of Computer and Information Science, effective Autumn Quarter 2003, Winter Quarter and Spring Quarter 2004.

STANLEY C. AHALT, Professor, Department of Electrical Engineering, effective Autumn Quarter 2003, Winter Quarter and Spring Quarter 2004.

JULIA F. ANDREWS, Professor, Department of History of Art, effective Autumn Quarter 2003, Winter Quarter and Spring Quarter 2004.

CHARLES M. ATKINSON, Professor, School of Music, effective Autumn Quarter 2003, Winter Quarter and Spring Quarter 2004.

MICHAEL R. FOSTER, Professor, Department of Aerospace Engineering and Aviation, effective Autumn Quarter 2003.

ALI KEYHANI, Professor, Department of Electrical Engineering, effective Autumn Quarter 2003, Winter Quarter and Spring Quarter 2004.

L. JAMES LEE, Professor, Department of Chemical Engineering, effective Autumn Quarter 2003.

RONGXING LI, Professor, Department of Civil and Environmental Engineering and Geodetic Science, effective Autumn Quarter 2003, Winter Quarter and Spring Quarter 2004.

JEFFERY D. MCNEAL, Professor, Department of Mathematics, effective Autumn Quarter 2003, Winter Quarter and Spring Quarter 2004.

JOSE R. OUBRERIE, Professor, Knowlton School of Architecture, effective Spring Quarter 2003.

THOMAS E. POSTLEWAIT, Professor, Department of Theatre, effective Autumn Quarter 2003, Winter Quarter and Spring Quarter 2004.

STEVEN A. RINGEL, Professor, Department of Electrical Engineering, effective Autumn Quarter 2003, Winter Quarter and Spring Quarter 2004.

ROBERTO G. ROJAS, Professor, Department of Electrical Engineering, effective Autumn Quarter 2003, Winter Quarter and Spring Quarter 2004.

PERSONNEL ACTIONS (contd)

Professional Improvement Leaves (contd)

MICHAEL B. CADWELL, Associate Professor, Knowlton School of Architecture, effective Autumn Quarter 2003, Winter Quarter and Spring Quarter 2004.

ROGER A. CRAWFIS, Associate Professor, Department of Computer and Information Science, effective Autumn Quarter 2003, Winter Quarter and Spring Quarter 2004.

REBECCA C. HARVEY, Associate Professor, Department of Art, effective Winter Quarter, Spring Quarter, and Autumn Quarter 2004.

GREGORY N. WASHINGTON, Associate Professor, Department of Mechanical Engineering, effective Autumn Quarter 2003, Winter Quarter and Spring Quarter 2004.

Emeritus Titles

JAMES O. ALBEN, Department of Molecular and Cellular Biochemistry, with the title Professor Emeritus, effective July 1, 2003.

WARREN F. LEE, Department of Agricultural, Environmental, and Developmental Economics, with the title Professor Emeritus, effective April 1, 2003.

MARY R. SCHILLER, School of Allied Medical Professions, with the title Professor Emeritus, effective July 1, 2003.

MICHAEL M. FULTON, Agricultural Technical Institute, with the title Associate Professor Emeritus, effective April 1, 2003.

JIM A. GROSSIE, Department of Physiology and Cell Biology, with the title Associate Professor Emeritus, effective July 1, 2003.

ARNOLD L. MOKMA, Agricultural Technical Institute, with the title Associate Professor Emeritus, effective July 1, 2003.

DAVID A. MUNN, Agricultural Technical Institute, with the title Associate Professor Emeritus, effective July 1, 2003.

JAMES F. HAMILTON, Department of Internal Medicine, with the title Clinical Assistant Professor Emeritus, effective April 1, 2003.

KATHERINE A. KISKER, College of Nursing, with the title Instructor Emeritus, effective April 1, 2003.

RESOLUTIONS IN MEMORIAM

Resolution No. 2003-102

Synopsis: Approval of Resolutions in Memoriam is proposed.

RESOLVED, That the Board adopt the following Resolutions in Memoriam and that the President be requested to convey a copy to the families of the deceased.

RESOLUTIONS IN MEMORIAM (contd)

Lewis A. Hess

The Board of Trustees of The Ohio State University expresses its sorrow upon the death on January 31, 2003, of Lewis A. Hess, Professor Emeritus in the School of Physical Activity and Educational Services.

Professor Hess held Bachelor of Science and Master of Arts degrees from the University of Minnesota. He earned his Ed.D. degree from Teachers College, Columbia University.

Before coming to Ohio State he taught physical education and coached football and basketball in Sioux Falls, South Dakota, and was the high school athletic director in Red Wing, Minnesota. In 1936 he was chosen as a delegate to the International Sport Student Congress and Olympic Games in Berlin.

Professor Hess served as a physical and military training officer in the United States Navy from 1942 to 1946. He left active duty with the rank of lieutenant commander and was promoted to the rank of captain in the U.S. Naval Reserve.

After the war, in 1946, Dr. Hess joined the Ohio State faculty where he became the director of the men's division of physical education. In 1969 he became the first director of the School of Health, Physical Education, and Recreation. Dr. Hess is credited with providing the leadership in initiating and developing the Exercise Physiology Laboratory, which continues to be nationally recognized and respected.

Professor Hess served his profession well. He was the president of the Association for Health, Physical Education, and Recreation in both South Dakota and Ohio. He was chairperson of the University and College Administrators Council of the American Association for Health, Physical Education, and Recreation; was a member of the University Program Advisory Committee for the Mentally Retarded and Handicapped; and served on the liaison Committee of the Ohio Youth Commission.

He was editor of the *Merrill Sports Series* published by Merrill Publishing Company. He was a member of Phi Delta Kappa and Kappa Delta Phi, both national honorary education societies. He was presented the Honor Award of the Administrative Council of the American Alliance for Health, Physical Education, and Recreation. After retirement, he assumed presidency of the University Retirees Association.

Professor Hess was a gifted teacher and administrator. Along with his teaching and administrative responsibilities, he served as advisor to more than 50 graduate students who completed the Ph.D. degree. He retired in 1978 after 32 years on the faculty, leaving his colleagues and former students a rich legacy of excellence in teaching, scholarship, and service.

On behalf of the University community, the Board of Trustees expresses to the family of Professor Lewis A. Hess its deepest sympathy and sense of understanding of their loss. It was directed that this resolution be inscribed upon the minutes of the Board of Trustees and that a copy be tendered to his family as an expression of the Board's heartfelt sympathy.

Daniel Howland, Sr.

The Board of Trustees of The Ohio State University expresses its sorrow upon the death on February 22, 2003, of Dr. Daniel Howland, Sr., Professor Emeritus in the Department of Management Sciences.

Dr. Howland was born in East Greenwich, Rhode Island, on June 11, 1915. He received his Sc.B. degree in engineering from Brown University in 1949 and his M.A. (psychology) and Ph.D. (psychology and industrial engineering) degrees from The Ohio State University in 1952 and 1955, respectively.

RESOLUTIONS IN MEMORIAM (contd)

Daniel Howland, Sr. (contd)

Daniel Howland had a life-long passion for sailing and the sea and as a Captain in the Naval Reserves, chose to serve his active duty aboard submarines. As a boy, he earned his pilot's license before his driver's license.

Prior to beginning his graduate work at Ohio State in 1951, Dr. Howland held engineering positions in the airline industry where, in 1949, he became Piedmont Airlines' first flight engineer. He spent his entire academic career at Ohio State, beginning as an assistant professor of industrial engineering in 1955 and retiring as a professor in the Department of Management Sciences in the College of Business (then named the College of Administrative Science) in 1983. He was awarded the professor emeritus title effective December 31, 1983.

While affiliated with the College of Administrative Science, Dr. Howland was asked to present his paper on the "Cybernetic Modeling of Adaptive Man-Machine Systems" in Cambridge, England; was named Dean's Research Professor in 1980; and served on the University and College research committees. He was also listed in *Who's Who in Engineering, American Men of Science*, and *Dictionary of International Biography, Eighth Edition*.

Dr. Howland's research in adaptive systems research and practice was of interest to the Air Force and he became an operation analyst in their Foreign Technology Division, Wright-Patterson Air Force Base, in 1981. His affiliation with the Air Force, and the required commute to Dayton, continued until January 2003.

Active in professional affairs, Dr. Howland had been a member of the American Public Health Association, American Psychological Association, New York Academy of Sciences, and national science honor society Sigma Xi. He was a past president of the Operations Research Club of Central Ohio and held memberships in the American Society for Cybernetics, the Human Factors Society of America, and the American Association for the Advancement in Science, among others. He also served as a member of the U.S. Public Health Service National Advisory Committee.

On behalf of the University community, the Board of Trustees expresses to the family and friends of Professor Daniel Howland, Sr., its deepest sympathy and sense of understanding of their loss. It was directed that this resolution be inscribed upon the minutes of the Board of Trustees and that a copy be tendered to his family as an expression of the Board's heartfelt sympathy.

Alan J. Markworth

The Board of Trustees of The Ohio State University expresses its sorrow upon the death on February 12, 2003, of Alan J. Markworth, Professor in the Department of Materials Science and Engineering.

Professor Markworth received his Bachelor of Science degree (with honors) in physics from Case Institute of Technology in 1959; and a Master's degree in physics in 1961 and Ph.D. degree in physics in 1969, both from The Ohio State University. He was a physicist and researcher at Battelle Memorial Institute for 29 years and in 1995 he returned to Ohio State as a professor in materials science and engineering. He was also an adjunct professor of physics at Ohio University for over 13 years. Dr. Markworth was president of Markworth International Corporation.

Dr. Markworth's teaching and scholarship interests were directed to the modeling of nonlinear and chaotic materials-related phenomena. His research activities ranged from the formation of snow crystals to the erosion-corrosion of functionally graded materials. His work on chaos in kinetics in materials was particularly noteworthy. He was known for his collaboration with scientists around the world, most notably his work with researchers at Moscow State University.

RESOLUTIONS IN MEMORIAM (contd)

Alan J. Markworth (contd)

He had a lengthy list of manuscripts and professional presentations, all of which were marked by clarity and significance.

Professor Markworth served Ohio State with true passion and humbly used his gifts for the benefit of others. Students cherished him because he was an outstanding teacher, inside the classroom and beyond. He often mentored those who needed additional instruction in physics and engineering. His colleagues valued his helpfulness and friendship. He never sought glory or wanted recognition; his joy came when others succeeded. Dr. Markworth volunteered his time to acquaint new students and their parents during orientation to the benefits of Ohio State. He also worked with students in Ohio State's honors program.

Dr. Markworth was an active member of First Community Church, serving on the Governing Board, the Deaconate, and Stephens Ministry. He supported and encouraged the efforts of women in their education and professional roles. He was a loving father, grandfather, and foster father.

On behalf of the University community, the Board of Trustees expresses to the family of Professor Alan J. Markworth its deepest sympathy and sense of understanding of their loss. It was directed that this resolution be inscribed upon the minutes of the Board of Trustees and that a copy be tendered to his family as an expression of the Board's heartfelt sympathy.

REPORT OF RESEARCH CONTRACTS AND GRANTS

Resolution No. 2003-103

Synopsis: The reports on research and other sponsored program contracts and grants and the summary for February 2003 are presented for Board acceptance.

WHEREAS monies are solicited and received on behalf of the University from governmental, industrial, and other agencies in support of research, instructional activities, and service; and

WHEREAS such monies are received through The Ohio State University Research Foundation:

NOW THEREFORE

BE IT RESOLVED, That the research agreement between The Ohio State University and The Ohio State University Research Foundation for the contracts and grants reported herein during the month of February 2003 be approved.

REPORT ON UNIVERSITY DEVELOPMENT

Resolution No. 2003-104

Synopsis: The report on the receipt of gifts and the summary for February 2003 are presented for Board acceptance.

WHEREAS monies are solicited and received on behalf of the University from alumni, industry, and various individuals in support of research, instructional activities, and service; and

REPORT ON UNIVERSITY DEVELOPMENT (contd)

WHEREAS such gifts are received through The Ohio State University Development Fund and The Ohio State University Foundation; and

WHEREAS this report includes the establishment of eleven (11) new named endowed funds, the amendment of one (1) named endowed professorship, and the amendment of three (3) named endowed funds:

NOW THEREFORE

BE IT RESOLVED, That the acceptance of the report from The Ohio State University Development Fund and The Ohio State University Foundation during the month of February 2003 be approved.

TOTAL UNIVERSITY PRIVATE SUPPORT

July through February
2001-02 Compared to 2002-03

GIFT RECEIPTS BY DONOR TYPE

	Dollars July through February		
	<u>2001-02</u>	<u>2002-03</u>	<u>%Change</u>
Individuals:			
Alumni (Current Giving)	\$25,023,745	\$27,056,157	8
Alumni (From Bequests)	<u>3,910,598</u>	<u>2,664,044</u>	(32)
Alumni Total	\$28,934,343	\$29,720,201	3
Non-Alumni (Current Giving)	\$11,191,493	\$13,769,113	23
Non-Alumni (From Bequests)	<u>2,791,735</u>	<u>3,762,130</u>	35
Non-Alumni Total	\$13,983,228	\$17,531,243	25
Individual Total	\$42,917,571	\$47,251,444	10 ^A
Corporations/Corp/Foundations	\$27,567,070	\$28,367,855	3
Private Foundations	\$14,766,787	\$14,420,659	(2)
Associations and Other Organizations	<u>\$3,065,428</u>	<u>\$5,034,645</u>	64 ^B
Total	\$88,316,856	\$95,074,603	8

NOTES

A Individual giving is up 10% largely due to the fact that gifts of \$10,000 or more are up 16% (360 gifts for \$28.6 million last year; 420 gifts for \$33.1 million this year).

B Giving from associations and other organizations at the \$10,000 or more level is up 110% for July- February of the fiscal year (\$3.9 million from 64 gifts this year; \$1.9 million from 65 gifts last year).

REPORT ON UNIVERSITY DEVELOPMENT (contd)

TOTAL UNIVERSITY PRIVATE SUPPORT (contd)

July from February
2001-02 Compared to 2002-03

GIFT RECEIPTS BY PURPOSE

	Dollars July through February		
	<u>2001-02</u>	<u>2002-03</u>	<u>% Change</u>
Gift Receipts to Current Use and Endowment Funds:			
Buildings/Equipment	\$15,779,918	\$19,205,017	22
Faculty Support	\$9,854,204	\$9,213,036	(7)
Program Support	\$46,536,490	\$49,665,988	7
Student Financial Aid	\$9,553,750	\$11,603,325	21
Annual Funds-Colleges/Departments	\$5,745,894	\$4,752,429	(17)
Annual Funds-University	<u>\$846,600</u>	<u>\$634,808</u>	(25)
Total	\$88,316,856	\$95,074,603	8

GIFT ADDITIONS TO ENDOWMENT

Dollars
July through February

<u>2001-02</u>	<u>2002-03</u>	<u>% Change</u>
\$27,910,885	\$28,884,810	3

REPORT ON UNIVERSITY DEVELOPMENT (contd)

THE OHIO STATE UNIVERSITY DEVELOPMENT FUND

	<u>Previous Gifts</u>	<u>Current Gifts</u>	<u>Total Gifts</u>
<u>Change in Name and Description of Named Professorship</u>			
From: The University Pathology Services Professorship			
To: The Donald A. Senhauser, M.D., Professorship in Pathology			
<u>Establishment of Named Endowed Funds</u>			
The John Mac and Nancy Earls Cassady Scholarship Fund in Pharmacy (Used to provide one or more scholarships to a graduate student(s) in the College of Pharmacy; provided by gifts from John Mac and Nancy Earls Cassady and friends of the College of Pharmacy)		\$61,813.75	\$61,813.75
Polar Archives Support Endowment Fund (Used to create a small operating fund for the Polar Archives Program; provided by operating cash from the Byrd Polar Archival Program Fund)		\$40,000.00	\$40,000.00

Change in Name and Description of Named Endowed Fund

From: The Geraldine McFadden Kuhn Scholarship
To: The Geraldine McFadden Kuhn Scholarship Fund

Change in Description of Named Endowed Fund

The Edmund M. Kagay Scholarship Fund

THE OHIO STATE UNIVERSITY FOUNDATION

	<u>Previous Gifts</u>	<u>Current Gifts</u>	<u>Total Gifts</u>
<u>Establishment of Named Endowed Funds</u>			
DeeDee and Herb Glimcher Program Fund (Used to provide ongoing support for the DeeDee and Herb Glimcher Program Fund at the Wexner Center for the Arts; provided by a gift from DeeDee and Herb Glimcher)		\$100,000.00	\$100,000.00
The Shawn Springs Majority of One Scholarship Fund (Used to provide scholarships for Ohio State University students who are members of the Department of Athletics Majority of One program; provided by gifts from Shawn Springs)		\$50,000.00	\$50,000.00

REPORT ON UNIVERSITY DEVELOPMENT (contd)

THE OHIO STATE UNIVERSITY FOUNDATION (contd)

	<u>Previous Gifts</u>	<u>Current Gifts</u>	<u>Total Gifts</u>
<u>Establishment of Named Endowed Funds (contd)</u>			
The William U. Gibson, M.D., Merit Scholarship Fund in Medicine (Used to provide a single scholarship annually to a second or third-year medical student enrolled in the College of Medicine and Public Health; provided by gifts from the estate of William U. Gibson, M.D.)		\$30,715.00	\$30,715.00
The Iams Innovation Fund (Used at the discretion of the Dean of Veterinary Medicine to further the activities of the college; provided by a gift from Iams Company)		\$30,000.00	\$30,000.00
Montgomery County 4-H Endowment Fund (Used to provide program funding for the urban, suburban, and rural 4-H youth, teens, and volunteers of the Montgomery County 4-H Youth Development program; provided by gifts from friends of Montgomery County 4-H)		\$26,317.00	\$26,317.00
Greene County 4-H Endowment Fund (Used to support the Greene County 4-H Youth Development Program; provided by gifts from friends of Greene County 4-H)		\$25,903.00	\$25,903.00
The Fred O. and Joan G. Hartman Excellence in Pomology Endowment Fund (Used to support faculty and student excellence in pomology; provided by gifts from Dr. Fred O. Hartman)		\$25,000.00	\$25,000.00
The Huff Family Athletic Scholarship Fund Honoring Coach Jim Tressel (Used to supplement the grant-in-aid scholarship costs of a student-athlete who is a member of the men's varsity football team; provided by a gift from Thomas and Kathy Huff)		\$25,000.00	\$25,000.00
The Michael and Martha Passe Scholarship Fund (Used to provide a scholarship in the Knowlton School of Architecture; provided by a gift from Michael Passe and Martha Passe)		\$25,000.00	\$25,000.00
<u>Change in Name and Description of Named Endowed Fund</u>			
From: The Ronald L. Stuckey Stone Laboratory Endowment Fund			
To: The Ronald L. Stuckey Stone Laboratory Teaching Endowment Fund			
Total		<u>\$439,748.75</u>	<u>\$439,748.75</u>

REPORT ON UNIVERSITY DEVELOPMENT (contd)

THE OHIO STATE UNIVERSITY DEVELOPMENT FUND

Change in Name and Description of Named Endowed Professorship

The Donald A. Senhauser, M.D., Professorship in Pathology

The University Pathology Services Professorship was established July 12, 2002, by the Board of Trustees of The Ohio State University, with gifts from University Pathology Services and from other friends and colleagues of Donald A. Senhauser, M.D. (Professor Emeritus and former Chairperson of the Department of Pathology) of Columbus, Ohio. This professorship has been established in honor of Dr. Senhauser in recognition of his dedication and leadership as a physician and educator in the Department of Pathology. The name and description were revised April 4, 2003.

All gifts are to be invested in the University's Permanent Endowment Fund, under the rules and regulations adopted by the Board of Trustees of The Ohio State University, with the right to invest and reinvest as occasion dictates.

The annual income shall be used for a professorship position in the Department of Pathology (or a chair position if funding reaches \$1,500,000), supporting the advancement of medical knowledge in the field through research, education, and improved patient care outcomes. This professorship (or chair) shall also encourage participation and leadership in national and international organizations; and the promotion of the Department of Pathology and the discipline of pathology.

The appointment to The Donald A. Senhauser, M.D., Professorship (or Chair) shall be made at the recommendation of the senior vice president for Health Sciences and dean of the College of Medicine and Public Health, with a preference for it to be the chairperson of the Department of Pathology in the College of Medicine and Public Health. The activities of the holder of the professorship or the chair shall be reviewed no less than every five years by the senior vice president and dean to determine compliance with the intent of the donors as well as the academic and research standards of the University.

It is the desire of the donors that this fund should benefit the University in perpetuity. If the need for this fund should cease to exist or so diminish as to provide unused income, then another use shall be designated by the Board of Trustees in consultation with the senior vice president for Health Sciences and dean of the College of Medicine and Public Health and with the chairperson of the Department of Pathology in order to carry out the desire of the donors.

Establishment of Named Endowed Funds

The John Mac and Nancy Earls Cassady Scholarship Fund in Pharmacy

The John Mac and Nancy Earls Cassady Scholarship Fund in Pharmacy was established April 4, 2003 by the Board of Trustees of The Ohio State University with gifts from John Mac and Nancy Earls Cassady of Worthington, Ohio, and friends of the College of Pharmacy who share and support their vision for the future of The Ohio State University College of Pharmacy and the importance of providing access to excellent students.

John Mac Cassady served as dean of the College of Pharmacy from 1988-2003. In his 15 years of leadership, the College experienced an increase in alumni participation and endowment growth, as well as the attraction and retention of distinguished faculty on a national and international level. These attributed to the success that consistently enabled the College to maintain its status as one of the top colleges of pharmacy in the nation.

All gifts are to be invested in the University's Permanent Endowment Fund, under the rules and regulations adopted by the Board of Trustees of The Ohio State University, with the right to invest and reinvest as occasion dictates.

REPORT ON UNIVERSITY DEVELOPMENT (contd)

THE OHIO STATE UNIVERSITY DEVELOPMENT FUND (contd)

Establishment of Named Endowed Funds (contd)

The John Mac and Nancy Earls Cassady Scholarship Fund in Pharmacy (contd)

The annual income shall be used to provide one or more scholarship(s) to a graduate professional student(s) in the College of Pharmacy who exhibits exemplary academic excellence. The scholarship will be annually renewed with funds to support the student(s) with a full ride scholarship, which includes tuition, fees, and books while attending the College of Pharmacy. Scholarships will be awarded in consultation with the University Committee on Student Financial Aid.

It is the desire of the donors that this fund should benefit the University in perpetuity. If the need for this fund should cease to exist or so diminish as to provide unused income, then another use shall be designated by the Board of Trustees in consultation with the dean of the College of Pharmacy in order to carry out the desire of the donors.

\$61,813.75

Polar Archives Support Endowment Fund

The Polar Archives Support Endowment Fund was established April 4, 2003, by the Board of Trustees of The Ohio State University with operating cash from the Byrd Polar Archival Program Fund.

All gifts are to be invested in the University's Permanent Endowment Fund, under the rules and regulations adopted by the Board of Trustees of The Ohio State University, with the right to invest and reinvest as occasion dictates.

The annual income shall be used to create a small operating fund for the Polar Archives Program. It will be used to purchase preservation supplies, do exhibits, travel, pay student employees, purchase collections, etc. All activities common to an operating budget, which currently does not exist for the Polar Archives Program.

It is the desire of the donor that this fund should benefit the University in perpetuity. If the need for this fund should cease to exist or so diminish as to provide unused income, then another use shall be designated by the Board of Trustees in consultation with the director of the Byrd Polar Archival Program, the director of the Byrd Polar Research Center, and the Office of Research in order to carry out the intended use of these funds as stated in the paragraph above.

\$40,000.00

Change in Name and Description of Named Endowed Fund

The Geraldine McFadden Kuhn Scholarship Fund

The Geraldine McFadden Kuhn Scholarship endowment was established February 5, 1988, by the Board of Trustees of The Ohio State University with gifts from Wayne Heskett Kuhn (B.M.E. 1941), of Marion, Ohio. The name and description were revised April 4, 2003.

All gifts are to be invested in the University's Permanent Endowment Fund, under the rules and regulations adopted by the Board of Trustees of The Ohio State University, with the right to invest or reinvest as occasion dictates.

REPORT ON UNIVERSITY DEVELOPMENT (contd)

THE OHIO STATE UNIVERSITY DEVELOPMENT FUND (contd)

Change in Name and Description of Named Endowed Fund (contd)

The Geraldine McFadden Kuhn Scholarship Fund (contd)

The annual income is to be used to provide one or more scholarships awarded annually to deserving students of merit who are attending The Ohio State University at Marion, with preference given to students expressing an interest in study leading to a degree awarded by the College of Human Ecology or the Department of English in the College of Humanities. The selection of the recipient is to be made upon the recommendation of The Ohio State University Marion Campus Scholarship Committee in consultation with the Dean of the Marion campus and the University Committee on Student Financial Aid.

It is the desire of the donor that this fund should benefit the University in perpetuity. If the need for this fund should cease to exist or so diminish as to provide unused income, then another use shall be designated by the Board of Trustees in consultation with the appropriate college dean, department chairman, or program administrative officer in order to carry out the desire of the donor.

Change in Description of Named Endowed Fund

The Edmund M. Kagay Scholarship Fund

The Edmund M. Kagay Scholarship Fund was established February 7, 2003, by the Board of Trustees of The Ohio State University with a gift from the estate of Edmund M. Kagay of Columbus, Ohio. The description was revised April 4, 2003.

All gifts are to be invested in the University's Permanent Endowment Fund, under the rules and regulations adopted by the Board of Trustees of The Ohio State University, with the right to invest and reinvest as occasion dictates.

The annual income shall be used to support merit-based language study abroad scholarships within the College of Humanities.

It is the desire of the donor that this fund should benefit the University in perpetuity. If the need for this fund should cease to exist or so diminish as to provide unused income, then another use shall be designated by the Board of Trustees in consultation with the Dean of the College of Humanities in order to carry out the desire of the donor.

THE OHIO STATE UNIVERSITY FOUNDATION

Establishment of Named Endowed Funds

DeeDee and Herb Glimcher Program Fund

The DeeDee and Herb Glimcher Program Fund at the Wexner Center for the Arts was established April 4, 2003, in accordance with the guidelines approved by the Board of Directors of The Ohio State University Foundation, with a gift from DeeDee (B.S.Land.Arch. *cum laude* 1988) and Herb Glimcher, of Columbus, Ohio.

All gifts are to be invested by the Foundation, under the rules and regulations adopted by the Foundation Board of Directors, with the right to invest and reinvest as occasion dictates.

The annual income shall be used to provide ongoing support for the DeeDee and Herb Glimcher Program Fund at the Wexner Center for the Arts.

REPORT ON UNIVERSITY DEVELOPMENT (contd)

THE OHIO STATE UNIVERSITY FOUNDATION (contd)

Establishment of Named Endowed Funds (contd)

DeeDee and Herb Glimcher Program Fund (contd)

The use of the annual income shall be directed by the Wexner Center Director in consultation with the Center's programming staff.

It is the desire of the donors that this fund should benefit the University in perpetuity. If the need for this fund should cease to exist or so diminish as to provide unused income, then another use shall be designated by the Foundation Board in consultation with the Wexner Center's Director and programming staff, or their successor, in order to carry out the desire of the donors.

\$100,000.00

The Shawn Springs Majority of One Scholarship Fund

The Shawn Springs Majority of One Scholarship Fund was established April 4, 2003, in accordance with the guidelines approved by the Board of Directors of The Ohio State University Foundation, with gifts from Shawn Springs, Seattle, Washington, on behalf of the Springs for Life Foundation.

All gifts are to be invested by the Foundation, under the rules and regulations adopted by the Foundation's Board of Directors, with the right to invest and reinvest as occasion dictates.

The annual income shall be used to create a scholarship benefiting Ohio State University students who are members of the Department of Athletics Majority of One program, a student organization developed to assist minority students at the University. Scholarships will be awarded in consultation with the University Committee on Student Financial Aid.

It is the desire of the donor that this fund should benefit the University in perpetuity. If the need for this fund should cease to exist (i.e. the Majority of One organization disbands or is no longer affiliated with The Ohio State University) or so diminish as to provide unused income, then it is the desire of the donor that the unused income and any subsequent income shall be used to provide a postgraduate scholarship for a minority student-athlete graduating from The Ohio State University pursuing a graduate degree following participation on a varsity intercollegiate sports team.

\$50,000.00

The William U. Gibson, M.D., Merit Scholarship Fund in Medicine

The William U. Gibson, M.D., Merit Scholarship Fund in Medicine was established April 4, 2003 in accordance with the guidelines approved by the Board of Directors of The Ohio State University Foundation with gifts from the estate of, and in memory of, William U. Gibson, M.D. (M.D. *cum laude* 1970) of Columbus, Ohio.

All gifts are to be invested by the Foundation, under the rules and regulations adopted by the Foundation Board of Directors of The Ohio State University with the right to invest and reinvest as occasion dictates.

The annual income shall be used to provide a single scholarship on an annual basis to a second- or third-year medical student enrolled in the College of Medicine and Public Health at The Ohio State University. The selection of the recipient shall be based on academic merit rather than financial need, and it is the desire of the donor that, to the extent consistent with applicable law,

REPORT ON UNIVERSITY DEVELOPMENT (contd)

THE OHIO STATE UNIVERSITY FOUNDATION (contd)

Establishment of Named Endowed Funds (contd)

The William U. Gibson, M.D., Merit Scholarship Fund in Medicine (contd)

consideration be given to a male student. Determination of the recipient shall be made at the recommendation of the senior vice president for Health Sciences and dean of the College of Medicine and Public Health in consultation with the College of Medicine and Public Health Committee for Scholarship Awards and with the University Committee on Student Financial Aid.

It is the desire of the donor that this fund should benefit the University in perpetuity. If the need for this fund should cease to exist or so diminish as to provide unused income, then another use shall be designated the Foundation Board in consultation with the senior vice president for Health Sciences and dean of the College of Medicine and Public Health in order to carry out the desire of the donor.

\$30,715.00

The Iams Innovation Fund

The Iams Innovation Fund was established April 4, 2003, in accordance with the guidelines approved by the Board of Directors of The Ohio State University Foundation with a gift from the Iams Company, Dayton, Ohio.

All gifts are to be invested by the Foundation, under rules and regulations adopted by the Foundation Board of Directors, with the right to invest and reinvest as occasion dictates.

The annual income will be used at the discretion of the dean of the College of Veterinary Medicine to further the activities of the college.

It is the desire of the donor that this fund should benefit the University in perpetuity. If the need for this fund should cease to exist or so diminish as to provide unused income, then another use shall be designated by the Foundation Board as recommended by the dean of the College of Veterinary Medicine in order to carry out the desire of the donor.

\$30,000.00

Montgomery County 4-H Endowment Fund

The Montgomery County 4-H Endowment Fund was established April 4, 2003, in accordance with the guidelines approved by the Board of Directors of The Ohio State University Foundation, with gifts from friends of Montgomery County 4-H.

All gifts are to be invested by the Foundation, under the rules and regulations adopted by the Foundation's Board of Directors, with the right to invest and reinvest as occasion dictates.

The annual income shall be used to provide a sound source of program funding for the urban, suburban, and rural 4-H youth, teens, and volunteers of the Montgomery County 4-H Youth Development program. This support may include, but is not limited to, the funding of scholarships and awards for 4-H members, volunteer leaders, and friends of 4-H; sponsoring seminars and programs; and purchasing material and services that will supplement 4-H programming or increase the visibility and public support for 4-H in Montgomery County. All expenditures from this fund will be approved by the Montgomery County 4-H Committee and the professional providing leadership to the Montgomery County 4-H program.

REPORT ON UNIVERSITY DEVELOPMENT (contd)

THE OHIO STATE UNIVERSITY FOUNDATION (contd)

Establishment of Named Endowed Funds (contd)

Montgomery County 4-H Endowment Fund (contd)

It is the desire of the donors that this fund should benefit the University in perpetuity. If the need for this fund should cease to exist or so diminish as to provide unused income, then another use shall be designated by the Foundation Board in consultation with the vice president for Agricultural Administration and University Outreach, and executive dean for Food, Agricultural, and Environmental Sciences, and the chairperson of the Department of Food, Agricultural, and Biological Engineering, or their successors, in order to carry out the desire of the donors.

\$26,281.00

Greene County 4-H Endowment Fund

The Greene County 4-H Endowment Fund was established April 4, 2003, in accordance with the guidelines approved by the Board of Directors of The Ohio State University Foundation, with gifts from friends of Greene County 4-H.

All gifts are to be invested by the Foundation, under the rules and regulations adopted by the Foundation's Board of Directors, with the right to invest and reinvest as occasion dictates.

The annual income shall be used to support the Greene County 4-H Youth Development Program. This support may include, but is not limited to, the funding of scholarships and awards for 4-H members, volunteer leaders, and friends of 4-H; sponsoring seminars and programs; and purchasing materials or services that will supplement 4-H programming or increase the visibility and public support for 4-H in Greene County. Scholarships will be awarded in consultation with the University Committee on Student Financial Aid. All expenditures from this fund shall be approved by the Greene County 4-H Committee and the professional providing leadership to the Greene County 4-H program.

It is the desire of the donors that this fund should benefit the University in perpetuity. If the need for this fund should cease to exist or so diminish as to provide unused income, then another use shall be designated by the Foundation Board in consultation with the Director for Ohio State University Extension and a committee representing the Greene County 4-H donors in order to carry out the desire of the donors.

\$25,903.00

The Fred O. and Joan G. Hartman Excellence in Pomology Endowment Fund

The Fred O. and Joan G. Hartman Excellence in Pomology Endowment Fund was established April 4, 2003, in accordance with the guidelines approved by the Board of Directors of The Ohio State University Foundation, with gifts from Dr. Fred O. Hartman, Professor Emeritus, (M.S. 1941, Ph.D. 1951), to celebrate and honor the memory of Joan G. Hartman, the career of Fred O. Hartman, and their life together.

All gifts are to be invested by the Foundation, under the rules and regulations adopted by the Foundations Board of Directors, with the right to invest and reinvest as occasion dictates.

The annual income shall be used to support faculty and student excellence in pomology including pomology research and teaching, pomology workshops, faculty and student participation in conferences devoted to improving pomology and equipment needed for research and demonstration of efficacy of new technology in the Department of Horticulture and Crop Sciences.

REPORT ON UNIVERSITY DEVELOPMENT (contd)

THE OHIO STATE UNIVERSITY FOUNDATION (contd)

Establishment of Named Endowed Funds (contd)

The Fred O. and Joan G. Hartman Excellence in Pomology Endowment Fund (contd)

It is the desire of the donor that this fund should benefit the University in perpetuity. If the need for this fund should cease to exist or so diminish as to provide unused income, then another use shall be designated by the Foundation Board in consultation with the vice president for Agricultural Administration and University Outreach, and executive dean for Food, Agricultural and Environmental Sciences, in consultation with the chair of the Department of Horticulture and Crop Sciences or their successor in order to carry out the desire of the donor.

\$25,000.00

The Huff Family Athletic Scholarship Fund Honoring Coach Jim Tressel

The Huff Family Athletic Scholarship Fund Honoring Jim Tressel was established April 4, 2003, in accordance with the guidelines approved by the Board of Directors of The Ohio State University Foundation, with a gift from Thomas and Kathy Huff, Mason, Ohio.

All gifts are to be invested by the Foundation, under the rules and regulations adopted by the Foundation's Board of Directors, with the right to invest and reinvest as occasion dictates.

The annual income shall be used to supplement the grant-in-aid scholarship costs of a student-athlete who is a member of the men's varsity football team pursuing an undergraduate degree at The Ohio State University. The recipients shall be selected by the director of Athletics in consultation with the varsity football coach and the University Committee on Student Financial Aid.

It is the desire of the donors that this fund should benefit the University in perpetuity. If the need for this fund should cease to exist or so diminish as to provide unused income, then another use shall be designated by the Foundation Board in consultation with the director of Athletics in order to carry out the desire of the donors.

\$25,000.00

The Michael and Martha Passe Scholarship Fund

The Michael and Martha Passe Scholarship Fund was established April 4, 2003, in accordance with the guidelines approved by the Board of Directors of The Ohio State University Foundation, with a gift from Michael Passe, Professor Emeritus, and Martha Passe, Assistant Professor Emeritus (Ph.D. 1957), of Columbus, Ohio.

All gifts are to be invested by the Foundation, under the rules and regulations adopted by the Foundation's Board of Directors, with the right to invest and reinvest as occasion dictates.

The annual income shall be used for a scholarship in the Knowlton School of Architecture. The student must demonstrate both academic excellence and financial need. The recipient will be selected by the director of the Knowlton School of Architecture in consultation with the Knowlton School Scholarship Committee and the University Committee on Student Financial Aid.

Michael Passe, a seminal figure in the history of The Ohio State University School of Architecture, taught electrical and mechanical systems to students of architecture from 1954 to 1993. He

REPORT ON UNIVERSITY DEVELOPMENT (contd)

THE OHIO STATE UNIVERSITY FOUNDATION (contd)

Establishment of Named Endowed Funds (contd)

The Michael and Martha Passe Scholarship Fund (contd)

received the Charles E. MacQuigg Outstanding Teacher Award in 1982, and was granted Professor Emeritus status in 1993. Martha Passe joined the Department of English at The Ohio State University in 1947 as a graduate assistant and candidate for a Ph.D., a degree she received in 1957. She taught American Literature and Technical Writing in the English Department until 1985, at which time she was granted Assistant Professor Emeritus status.

It is the desire of the donors that this fund should benefit the Knowlton School of Architecture at The Ohio State University in perpetuity. If the need for this fund should cease to exist or so diminish as to provide unused income, then another use shall be designated by the Foundation Board in consultation with the appropriate college dean, school director or program administrative officer in order to carry out the desire of the donors.

\$25,000.00

Change in Name and Description of Named Endowed Fund

The Ronald L. Stuckey Stone Laboratory Teaching Endowment Fund

The Ronald L. Stuckey Stone Laboratory Endowment Fund was established on February 2, 1996, in accordance with the guidelines approved by the Board of Directors of The Ohio State University Foundation. The fund was initiated by Ronald L. Stuckey, Professor Emeritus in the Department of Plant Biology and given to The Ohio State University Foundation by his brother, Darwin Stuckey. The name and description were revised April 4, 2003.

All gifts are to be invested by the Foundation, under the rules and regulations adopted by the Foundation Board of Directors, with the right to invest and reinvest as occasion dictates.

The annual income shall be used to support qualified faculty-level individuals to teach course offerings at Stone Laboratory. The first preference for support are faculty who teach plant science courses, which include field and laboratory work on identification, and ecological and geographical relations of plants. The fund use, and the determination of the teaching faculty to be supported by this fund, is the responsibility of the director of Stone Laboratory, his/her designee, or successor.

It is the desire of the donor that this fund should benefit the University in perpetuity. If the need for this fund should cease to exist or so diminish as to provide unused income, then another use shall be designated by Foundation Board in consultation with the director of Stone Laboratory or their successor in order to carry out the desire of the donor.

CAPITAL PROJECTS

Resolution No. 2003-105

REQUEST FOR DESIGN AUTHORIZATION

ANIMAL SCIENCE – ROOF REPLACEMENT
BAKER SYSTEM – ELEVATOR MODERNIZATION
FISHER AND GERLACH HALLS – DOOR AND JAMB REPLACEMENT
HITCHCOCK HALL – NORTH ENTRANCE IMPROVEMENTS
HOPKINS HALL – ELEVATOR REPLACEMENT
HOPKINS HALL – MECHANICAL SYSTEM IMPROVEMENTS
MCCRACKEN POWER PLANT – INTERNAL DRAINAGE SYSTEM
MCCRACKEN POWER PLANT – METERING UPGRADE
MCCRACKEN POWER PLANT – SPILL CONTROL
POSTLE HALL – FIRE ALARM REPLACEMENT
WEST CAMPUS CHILLED WATER UPGRADE & SCOTT HALL CHILLED WATER
REPLACEMENT

REQUEST FOR CONSTRUCTION AUTHORIZATION

FOOTBALL PRACTICE FIELD #3
LAUNDRY BUILDING RENOVATION
MACQUIGG LAB – CHILLER INSTALLATION
OHIO STADIUM – TURF REPLACEMENT

Synopsis: Authorization to enter into design contracts for the Animal Science – Roof Replacement, Baker System – Elevator Modernization, Fisher and Gerlach Halls – Door and Jamb Replacement, Hitchcock Hall – North Entrance Improvements, Hopkins Hall – Elevator Replacement, Hopkins Hall – Mechanical System Improvements, McCracken Power Plant – Internal Drainage System, McCracken Power Plant – Metering Upgrade, McCracken Power Plant – Spill Control, Postle Hall – Alarm Replacement, and West Campus – Chilled Water Upgrade & Scott Hall Chilled Water Replacement, and construction contracts for the Football Practice Field #3, Laundry Building Renovation, MacQuigg Lab – Chiller Replacement, and Ohio Stadium – Turf Replacement projects are requested.

WHEREAS at Animal Science the University desires to replace the built-up roof including new insulation and copper flashing; and

WHEREAS the preliminary project estimate is \$350,000, with funding provided by House Bill 675; and

WHEREAS at Baker Systems the University desires to modernize and upgrade the group of three elevators in order to meet current codes and standards; and

WHEREAS the preliminary project estimate is \$375,000, with funding provided by House Bill 675; and

WHEREAS at Fisher and Gerlach Halls the University desires to replace exterior doors and jambs with full continuous hinges, surface mounted overhead closers, and handicap operators; and

WHEREAS the preliminary project estimate is \$140,000, with funding provided by House Bill 675; and

WHEREAS at Hitchcock Hall the University desires to improve the vestibule, door hardware, pavement, lawn, and sidewalk at the north entrance from Woodruff; and

CAPITAL PROJECTS (contd)

WHEREAS the preliminary project estimate is \$250,000, with funding provided by House Bill 675; and

WHEREAS at Hopkins Hall the University desires to replace the elevator and modify the machine room including electrical service and air conditioning system; and

WHEREAS the preliminary project estimate is \$200,000, with funding provided by House Bill 675; and

WHEREAS at Hopkins Hall the University desires to improve the mechanical system including the dual duct heating/ventilating air handling units, dual duct heating/ventilating boxes and ducts, and size the units for present and future capacities; and

WHEREAS the preliminary project estimate is \$500,000, with funding provided by House Bill 675; and

WHEREAS at McCracken Power Plant the University desires to rehabilitate the internal drainage system to meet EPA requirements; and

WHEREAS the preliminary project estimate is \$225,000, with funding provided by House Bill 675; and

WHEREAS at McCracken Power Plant the University desires to upgrade the fuel, steam, water, and environmental compliance metering critical to operations and emission compliance to comply with national fire code regulations; and

WHEREAS the preliminary project estimate is \$250,000, with funding provided by House Bill 675; and

WHEREAS at McCracken Power Plant the University desires to provide spill control measures to meet EPA requirements related to fugitive emissions should a tank or pipe fail; and

WHEREAS the preliminary project estimate is \$300,000, with funding provided by House Bill 675; and

WHEREAS at Postle Hall the University desires to replace the main fire alarm panel and devices to meet current codes and provide total building fire and smoke coverage; and

WHEREAS the preliminary project estimate is \$300,000, with funding provided by House Bill 675; and

WHEREAS the University desires to upgrade the West Campus Chilled Water system and replace the chilled water system at Scott Hall; and

WHEREAS the preliminary project estimate is \$1,000,000, with funding provided by House Bill 675; and

WHEREAS at the Football Practice Field #3 the Department of Athletics desires to reconstruct the natural turf with new generation stabilizer mat and seeded with premium blend of ryegrass and associated irrigation; and

WHEREAS the construction document project cost is \$318,175, with funding provided by the Department of Athletics; and

WHEREAS at the Laundry Building the University desires to renovate a portion of the facility to house the Department of Physical Facilities' Tin and Mechanical/Electrical shops; and

CAPITAL PROJECTS (contd)

WHEREAS the construction document project cost is \$863,475, with funding provided by the Department of Physical Facilities; and

WHEREAS at MacQuigg Lab the Office of Research desires to install a chiller system for the sputtering unit located in room 270; and

WHEREAS the construction document project cost is \$50,000, with funding provided by a grant from the Ohio Board of Regents; and

WHEREAS at the Ohio Stadium the Department of Athletics desires to replace the stabilized bluegrass turf with new generation stabilizer mat and seeded with a premium blend of perennial ryegrass; and

WHEREAS the construction document project cost is \$207,125, with funding provided by the Department of Athletics:

NOW THEREFORE

BE IT RESOLVED, That the President and/or Senior Vice President for Business and Finance be authorized to enter into design contracts for the Animal Science – Roof Replacement, Baker System – Elevator Modernization, Fisher and Gerlach Halls – Door and Jamb Replacement, Hitchcock Hall – North Entrance Improvements, Hopkins Hall – Elevator Replacement, Hopkins Hall – Mechanical System Improvements, McCracken Power Plant – Internal Drainage System, McCracken Power Plant – Metering Upgrade, McCracken Power Plant – Spill Control, Postle Hall – Fire Alarm Replacement, and West Campus Chilled Water Upgrade & Scott Hall Chilled Water Replacement projects in accordance with established University and State of Ohio procedures, with all actions to be reported to this Board at the appropriate time; and

BE IT FURTHER RESOLVED, That the President and/or Senior Vice President for Business and Finance be authorized to enter into construction contracts, if satisfactory bids are received, for the Football Practice Field #3, Laundry Building Renovation, MacQuigg Lab – Chiller Replacement, and Ohio Stadium – Turf Replacement projects in accordance with established University and State of Ohio procedures, with all actions to be reported to this Board at the appropriate time.

(See Appendix XLI for background information and maps, page 983.)

ADOPTION OF THE OHIO STATE MANSFIELD REGIONAL CAMPUS MASTER PLAN

Resolution No. 2003-106

Synopsis: Adoption of the proposed Master Plan for The Ohio State University Mansfield Regional Campus as a part of the University Master Plan is proposed.

WHEREAS the Board of Trustees adopted Volume I ("University Context") and Volume II ("Long Range Plan") of the University Master Plan on October 6, 1995; and

WHEREAS as provided in the Long Range Concept Plan, the University is to prepare district plans for all the areas of the University, including the regional campuses, to provide more detailed planning and design guidelines for each area and to ensure that the Master Plan's principles are advanced in a way that is commensurate with the particular circumstances of each district; and

WHEREAS the University now has prepared a district plan for the Mansfield Regional Campus, bounded generally on the north and east by State Route 39, on the south by Walker's Lake Road, and on the west by Lexington Spring Mill Road; and

ADOPTION OF THE OHIO STATE MANSFIELD REGIONAL CAMPUS MASTER PLAN (contd)

WHEREAS the Mansfield Regional Campus Master Plan addresses planning and design issues specific to this campus, including campus context, location of future facilities, open space, natural features, vehicular and pedestrian circulation, parking and signage, design and development guidelines for future facilities and open space improvements; and

WHEREAS the appropriate University offices have reviewed the proposed Mansfield Regional Campus Master Plan and recommend its adoption:

NOW THEREFORE

BE IT RESOLVED, That the Board of Trustees hereby adopts the proposed Mansfield Regional Campus Master Plan as part of the University Master Plan and directs the appropriate University offices under the leadership of the Office of Business and Finance to proceed, consistent with the established University decision-making procedures, with additional planning activities provided for in the Plan and that the University shall report annually to this Board, through the Fiscal Affairs Committee, decisions made with respect to matters for which authority is delegated in accordance with the Master Plan.

(See Appendix XLII for background information and maps, page 1015.)

ADOPTION OF THE OHIO STATE MARION REGIONAL CAMPUS MASTER PLAN

Resolution No. 2003-107

Synopsis: Adoption of the proposed Master Plan for The Ohio State University Marion Regional Campus as a part of the University Master Plan is proposed.

WHEREAS the Board of Trustees adopted Volume I ("University Context") and Volume II ("Long Range Plan") of the University Master Plan on October 6, 1995; and

WHEREAS as provided in the Long Range Concept Plan, the University is to prepare district plans for all the areas of the University, including the regional campuses, to provide more detailed planning and design guidelines for each area and to ensure that the Master Plan's principles are advanced in a way that is commensurate with the particular circumstances of each district; and

WHEREAS the University now has prepared a district plan for the Marion Regional Campus, bounded generally by State Route 95/Mt. Vernon Avenue on the north, Marion Edison Road on the south and single family residential subdivisions on the east and west; and

WHEREAS the Marion Regional Campus Master Plan addresses planning and design issues specific to this campus, including campus context, location of future facilities, open space, natural features, vehicular and pedestrian circulation, parking and signage, design and development guidelines for future facilities and open space improvements; and

WHEREAS the appropriate University offices have reviewed the proposed Marion Regional Campus Master Plan and recommend its adoption:

NOW THEREFORE

BE IT RESOLVED, That the Board of Trustees hereby adopts the proposed Marion Regional Campus Master Plan as part of the University Master Plan and directs the appropriate University offices under the leadership of the Office of Business and Finance to proceed, consistent with the established University decision-making procedures, with additional planning activities provided for in the Plan and that the University shall report annually to this Board, through the Fiscal Affairs Committee, decisions made with respect to matters for which authority is delegated in accordance with the Master Plan.

ADOPTION OF THE OHIO STATE MARION REGIONAL CAMPUS MASTER PLAN (contd)

(See Appendix XLIII for background information and maps, page 1019.)

ADOPTION OF THE OHIO STATE NEWARK REGIONAL CAMPUS MASTER PLAN

Resolution No. 2003-108

Synopsis: Adoption of the proposed Master Plan for The Ohio State University Newark Regional Campus as a part of the University Master Plan is proposed.

WHEREAS the Board of Trustees adopted Volume I ("University Context") and Volume II ("Long Range Plan") of the University Master Plan on October 6, 1995; and

WHEREAS as provided in the Long Range Concept Plan, the University is to prepare district plans for all the areas of the University, including the regional campuses, to provide more detailed planning and design guidelines for each area and to ensure that the Master Plan's principles are advanced in a way that is commensurate with the particular circumstances of each district; and

WHEREAS the University now has prepared a district plan for the Newark Regional Campus, bounded generally country Club Drive on the west, residences along Granville Road to the south, single family residences and Foundation land on the east and single family residences on the north; and

WHEREAS the proposed Newark Regional Campus Master Plan addresses planning and design issues specific to this campus, including campus context, location of future facilities, open space, natural features, vehicular and pedestrian circulation, parking and signage, design and development guidelines for future facilities and open space improvements; and

WHEREAS the appropriate University offices have reviewed the proposed Newark Regional Campus Master Plan and recommend its adoption:

NOW THEREFORE

BE IT RESOLVED, That the Board of Trustees hereby adopts the proposed Newark Regional Campus Master Plan as part of the University Master Plan and directs the appropriate University offices under the leadership of the Office of Business and Finance to proceed, consistent with the established University decision-making procedures, with additional planning activities provided for in the Plan and that the University shall report annually to this Board, through the Fiscal Affairs Committee, decisions made with respect to matters for which authority is delegated in accordance with the Master Plan.

(See Appendix XLIV for background information and maps, page 1023.)

FY 2002-03 BUDGET RESCISSION

Resolution No. 2003-109

Synopsis: FY 2002-03 budget rescission plan is submitted for adoption.

WHEREAS the State of Ohio has cut funding to public institutions of higher education for the current fiscal year, FY 2003, resulting in a \$7.7 million (2.5%) reduction in the Columbus Campus State Share of Instruction and an \$11.2 million overall reduction in all line items for all campuses; and

FY 2002-03 BUDGET RESCISSION (contd)

WHEREAS the distribution of the State budget cuts needs to be coordinated with the University's ongoing commitment to achieve the goals of the Academic Plan; and

WHEREAS following appropriate University-wide consultation, a two-step plan has been developed to absorb the budget reduction:

NOW THEREFORE

BE IT RESOLVED, That the \$7.7 million reduction in State Share of Instruction to the Columbus Campus for FY 2002-03 be addressed by the reallocation of one-time funds as described in the attached materials; and

BE IT FURTHER RESOLVED, That specific State funding line items including the State Share of Instruction at the Regional Campuses, Research Challenge and Success Challenge and other line items will be reduced in FY 2003 by 2.5%; and

BE IT FURTHER RESOLVED, That the Board will adjust the FY 2003 resources and expenditure budgets to reflect specific changes (including increases in the State Share on Instruction due to enrollment increases) at the May meeting when the third quarter budget report is completed.

(See Appendix XLV for background information, page 1027.)

Upon motion of Mr. Borrer, seconded by Ms. Hendricks, the Board of Trustees adopted the foregoing resolutions by unanimous roll call vote, cast by Messrs. Sofia, Slane, McFerson, Borrer, and Judge Duncan, Mses. Longaberger, Hendricks, and Davidson.

--0--

Mr. Sofia:

Again, I'd like to extend our appreciation for John Riedl and his staff for hosting us this morning. I'd also like to extend our congratulations to Marianne Williamson for a well-deserved award.

--0--

Thereupon the Board adjourned to meet Friday, May 2, 2003, at The Ohio State University Longaberger Alumni House, Columbus, Ohio.

Attest:

David O. Frantz
Secretary

Zuheir Sofia
Vice Chairman

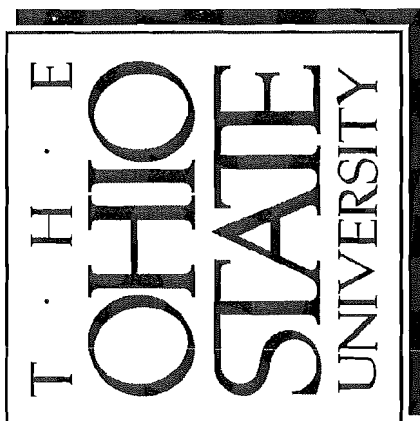

Compensation Benchmarks

Report to the Board of Trustees

April 4, 2003

Office of Human Resources

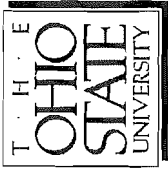

Critical Questions:

- How does our five-year history of raises compare with benchmark institutions?
- How do our current salaries compare with relevant markets?
- How are we investing our salary dollars?
- How do our benefits costs compare with other institutions?



Public Benchmark Institutions Faculty Salary Increase Budget 1998-99 through 2002-03

- Segments in BLUE are years where raises were equal to or greater than 5%
- Each column segment represents one year and is read in descending order from the top down:

2002-03
2001-02
2000-01
1999-00
1998-99

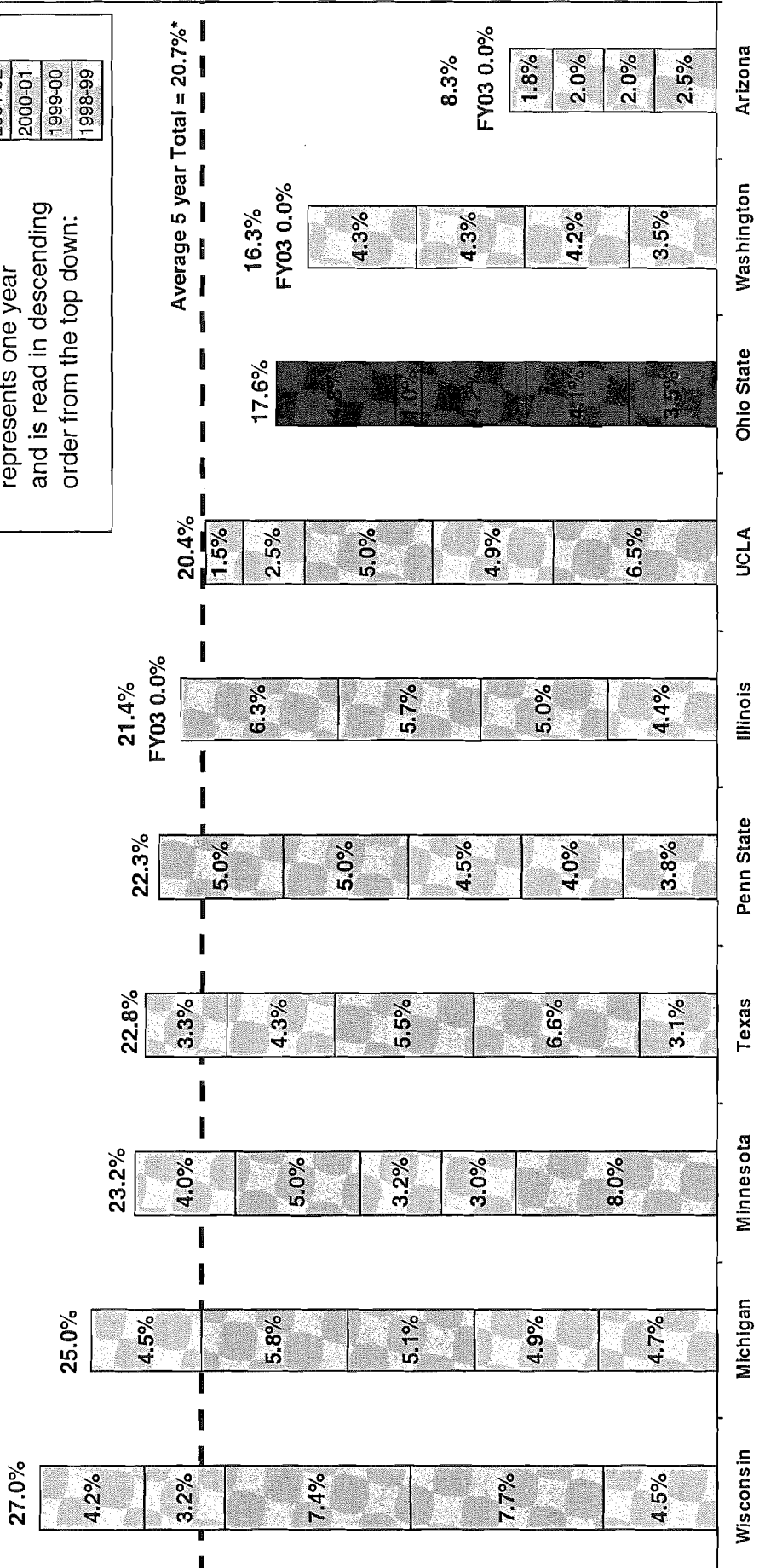

* Average excludes Ohio State



Comparative Faculty Salary Analysis Benchmark Universities Overall Average Salaries (in Thousands)

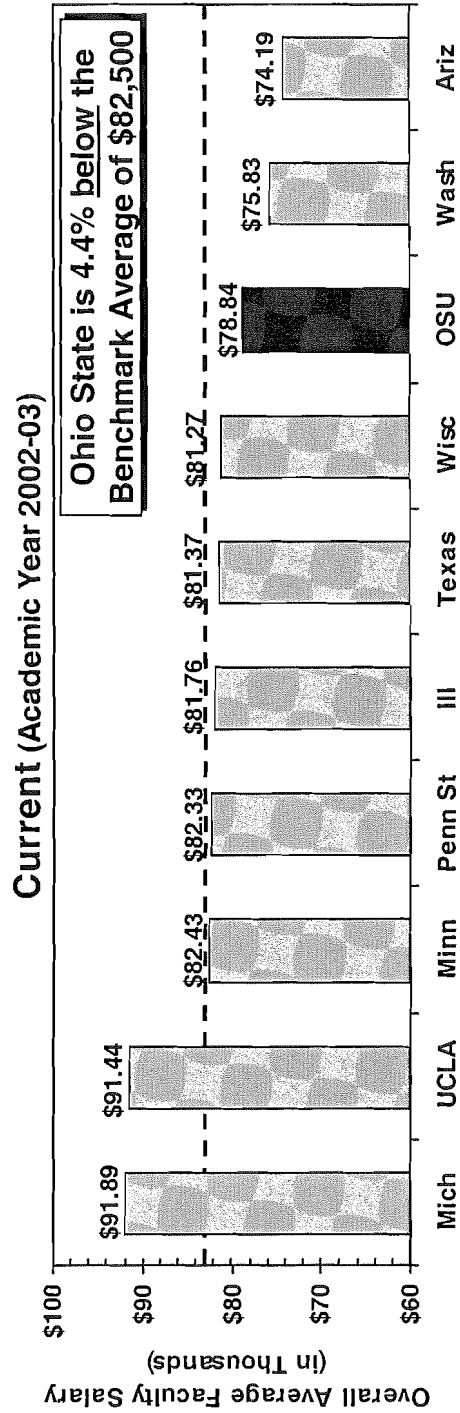
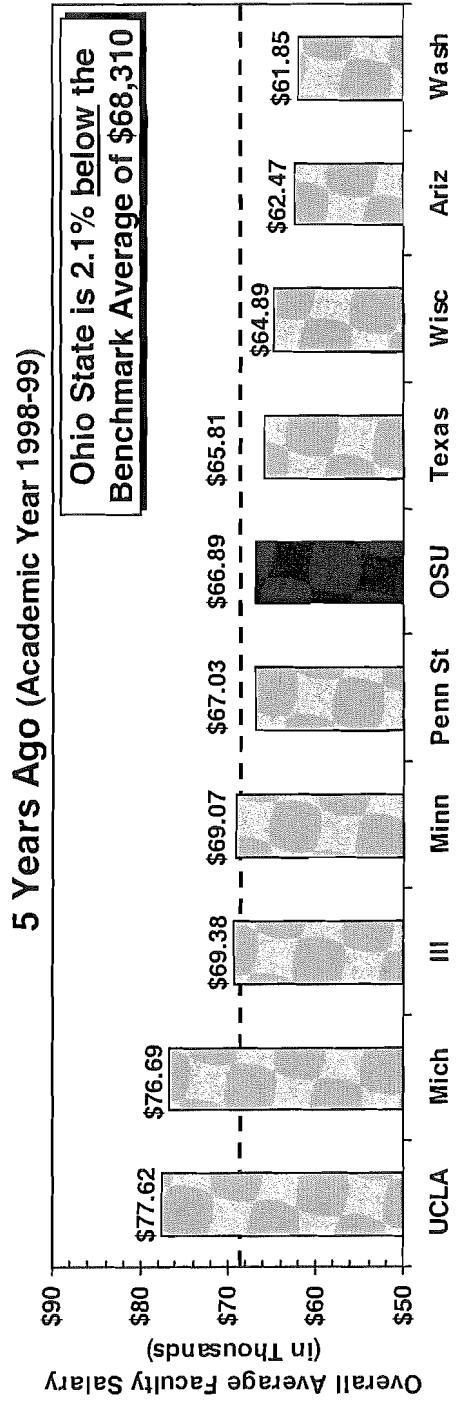

Note: Benchmark Averages exclude OSU



Staff Salaries Compared to External Markets (Adjusted for Benefits) FY 2002-03

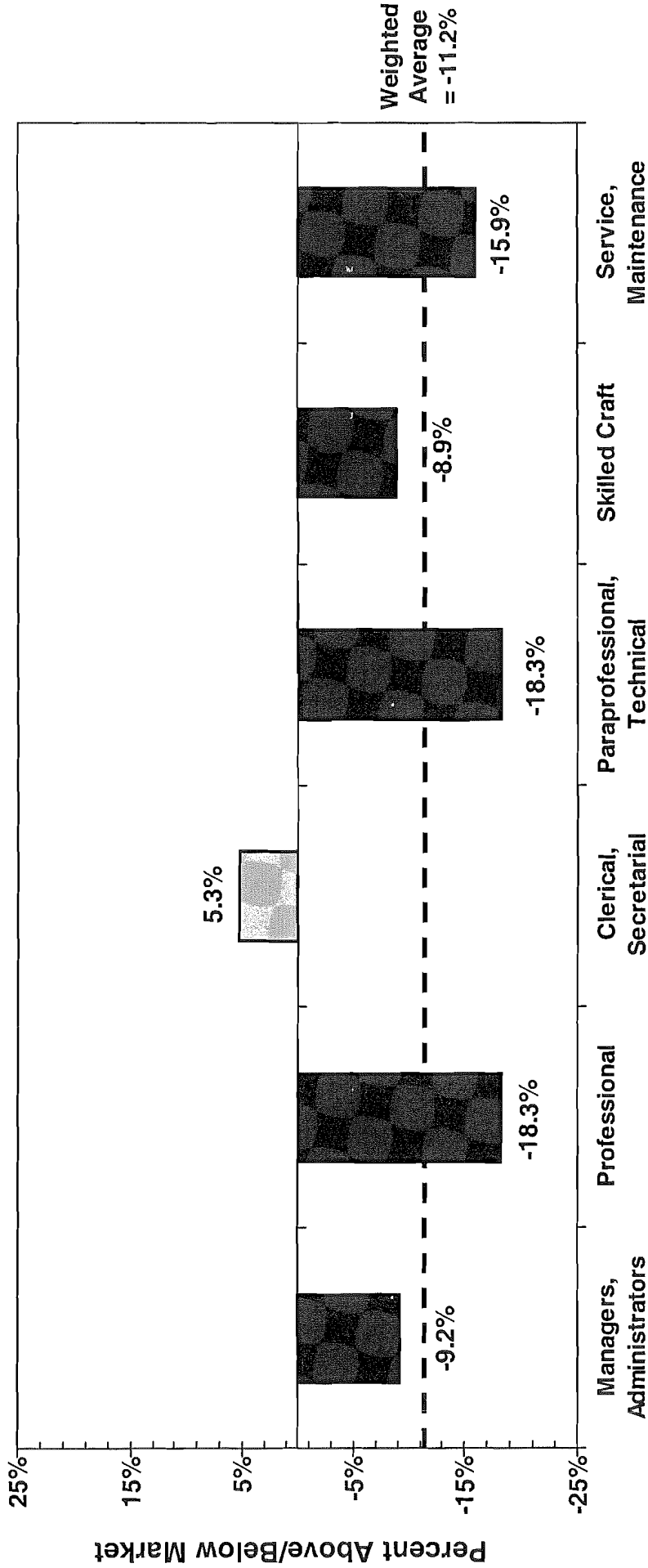

Notes:

General industry consists of local, regional and national public, private & non-profit organizations.

Ohio State excludes bargaining unit members, Hospitals, term and temporary employees.

Benefits Adjustment: Based on study by external consultant, external market data is adjusted by 3% to account for OSU's relative benefit advantage.



Staff Salaries Compared to the State of Ohio (in thousands) FY 2002-03

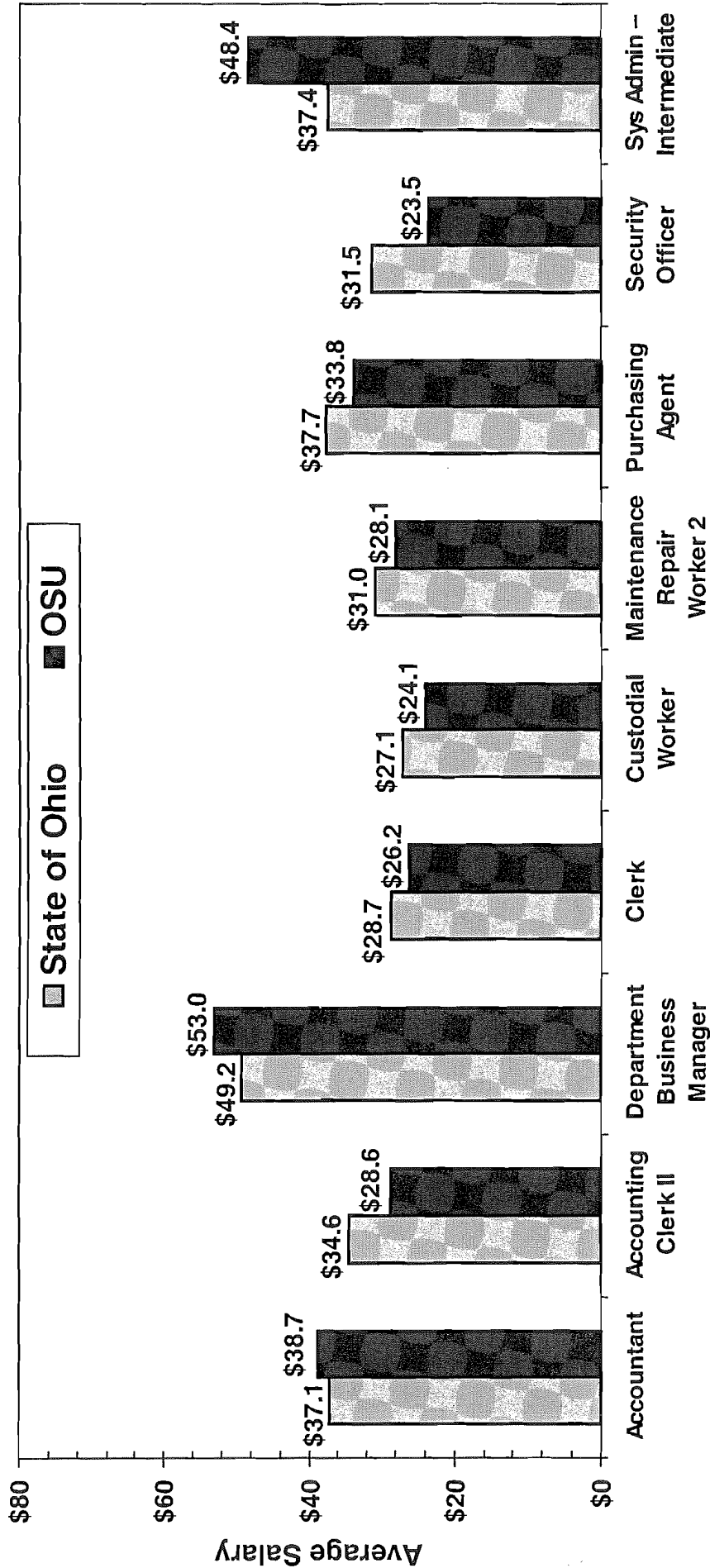

Note:
Excludes Hospitals, term and temporary employees.
These comparisons were obtained through OSU's routine market matching process, wherein we focus on positions at OSU and similar positions that exist at the State of Ohio as well as in other external market surveys. The classifications shown above are the subset which exist in all three (OSU, State, and other surveys) and have the greatest number of OSU employees. Therefore, this is not a complete analysis of all OSU employees compared to the State of Ohio.



Summary of Graduate Associate Financial Support - Resident Students Benchmark and Public CIC Institutions Average Net Financial Support and Medical Benefits for Autumn 2001

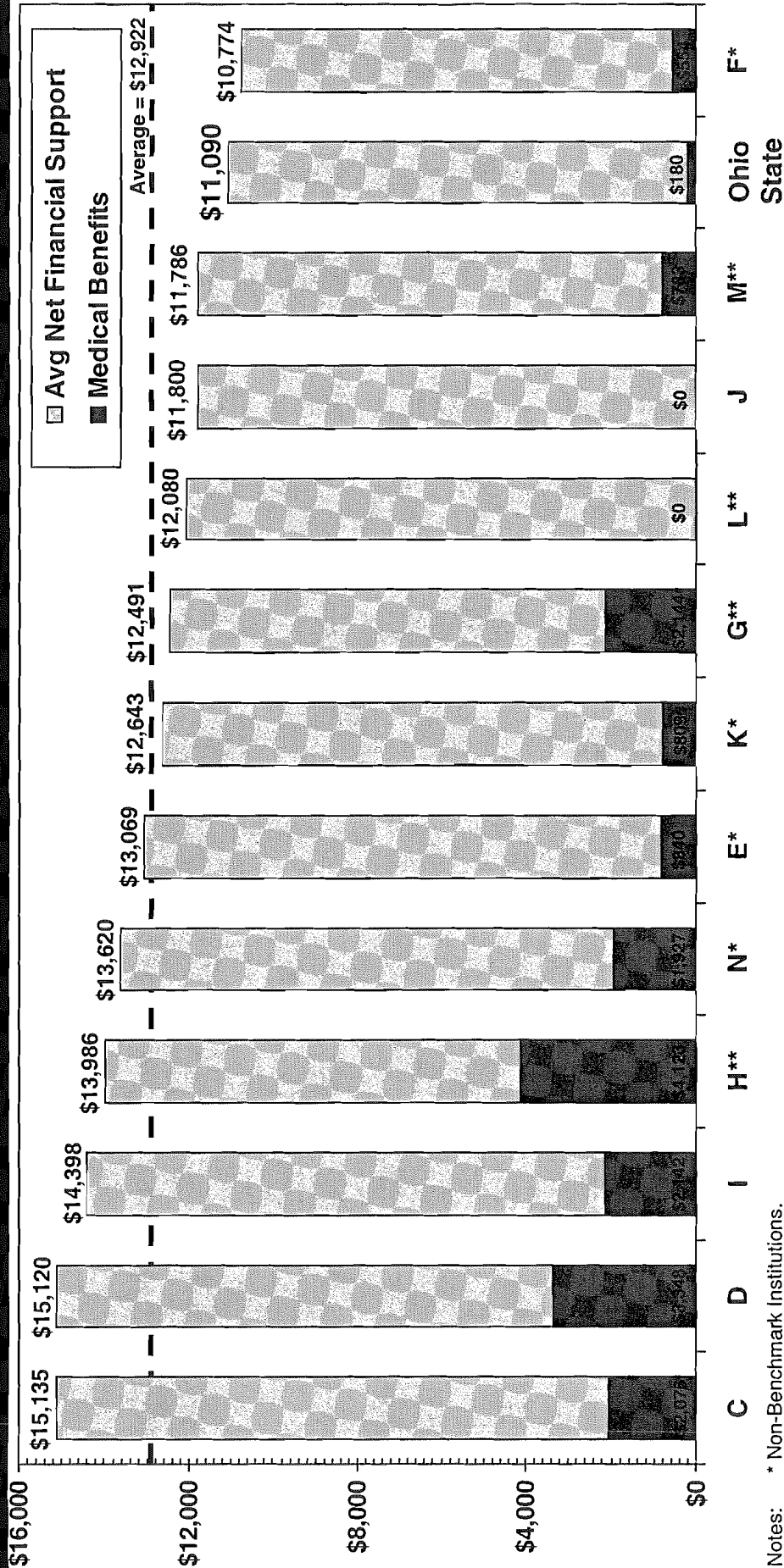

Notes: * Non-Benchmark Institutions.

** Stipend, fee and fee authorization data for Texas, Minnesota, Arizona and UCLA are as of AU 2000, as data for AU 2001 was unavailable. Data represents information for 9/10 month appointments.

Average Net Financial Support = Stipend + Medical Benefits - Fees.

Medical: Where multiple plans available, most common plan is reflected. If range of premiums, midpoint reflected.

Premiums represent composite of 80% single / 20% family coverage. UCLA's premium from AU 1998.

UCLA's fees and fee authorization are based on 12 credit hours vs. 9 for other institutions.

Institutions include: Arizona Ohio State Illinois Purdue Indiana Texas Iowa UCLA Michigan Washington Wisconsin Michigan State Minnesota

Sources: AAUDE Survey of Graduate Stipends, 2000-01 and 2001-02; medical premiums and parking fees - phone/web. *Office of Human Resources*



Distribution Summary of FY03 Salary Increases Average Investment (Salary + Bonus) Percentage by Gender and Ethnicity*

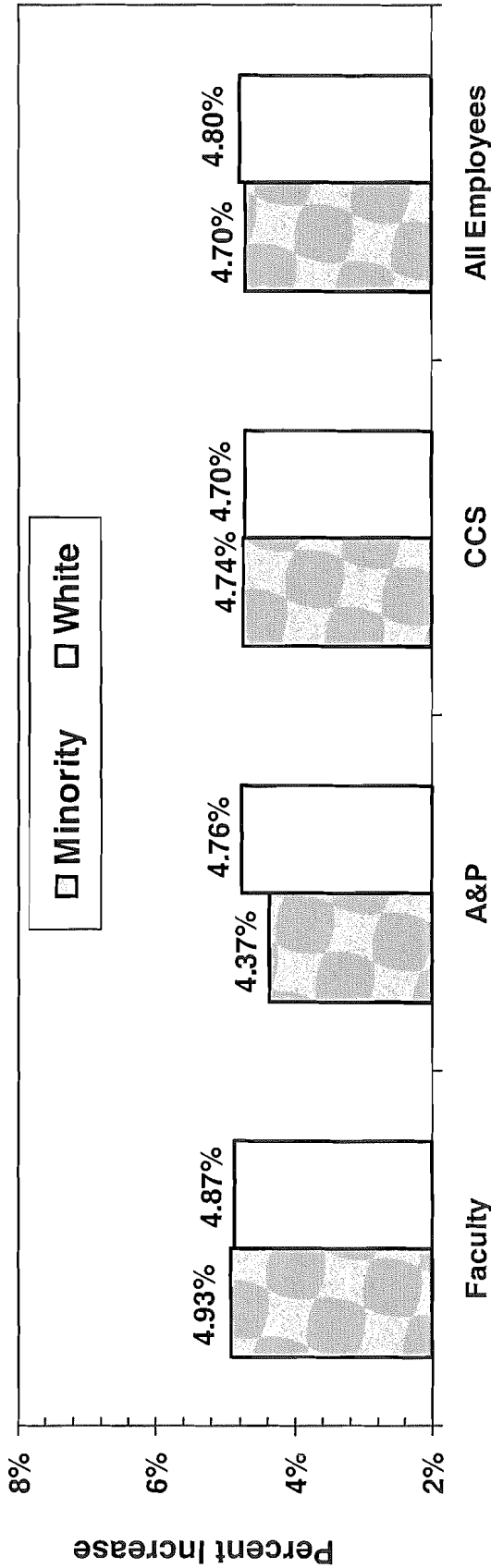
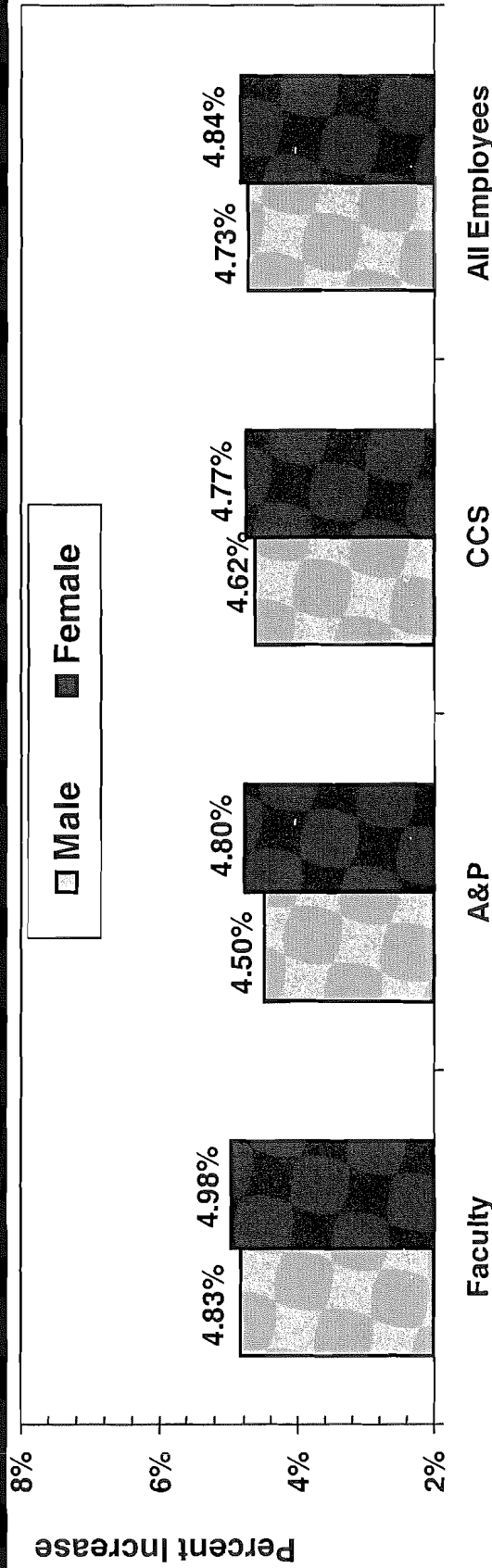

* Undisclosed ethnicity category excluded from report
Excludes University Leaders, Administrators, bargaining unit members, Hospitals, term and temporary employees.



Premium Cost Comparison Among AAU Data Exchange Institutions Estimated for FY 2003-04

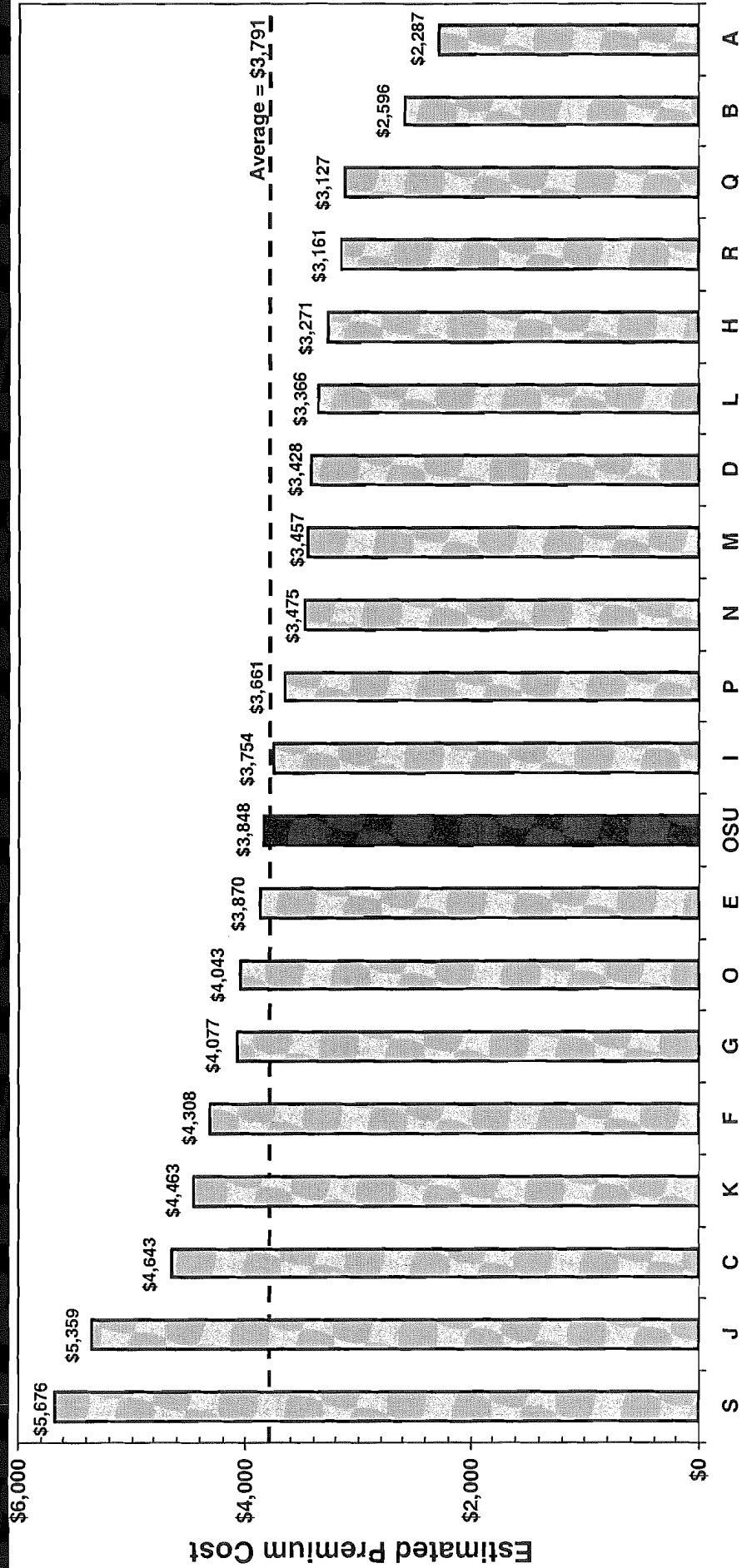

Source: AAUDE Survey of Benefits Programs, 2002-03
 Premium Cost (full funding cost) = Employer + Employee contributions
 Premium Cost reflects single coverage rate for medical coverage

- Institutions include:
- Indiana
 - Iowa
 - Ohio State
 - Texas
 - Texas A&M
 - Michigan
 - Penn State
 - UNC-Chapel Hill
 - Michigan State
 - Pittsburgh
 - Virginia
 - Minnesota
 - Purdue
 - Washington
 - Missouri
 - Rutgers
 - Wisconsin
 - MIT
 - SUNY-Buffalo



Benefits Expenditures as a Percentage of Total Compensation Expenditures Fiscal Year 1992-93 through 2002-03

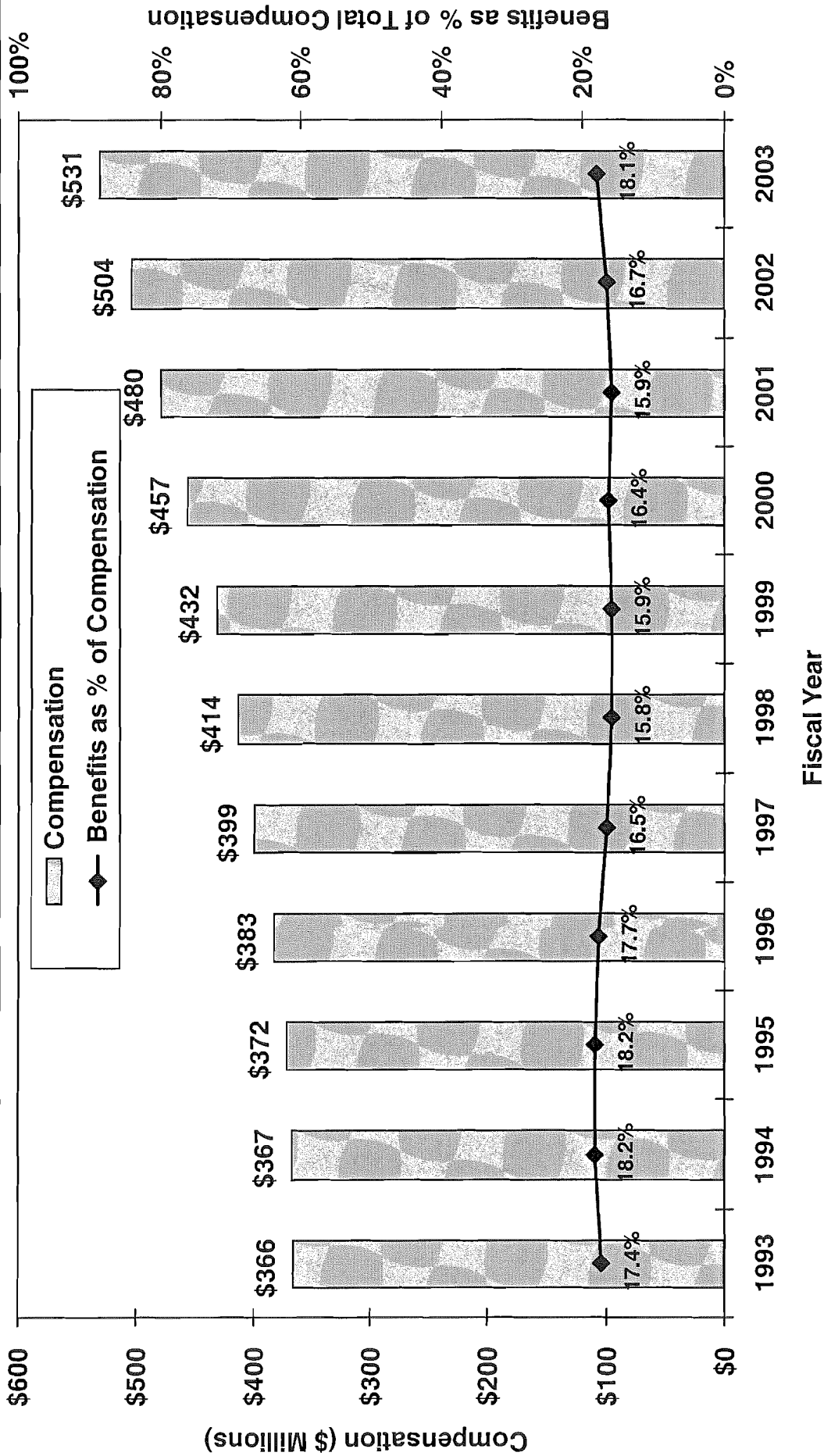

Source: General Funds Budget Model

Notes: Population includes anyone paid through General Funds at the Columbus campus
Benefits included are those used to calculate the Composite Rates: Retirement Plans, Medical Plans, Vision, Dental, Group Life, LT Disability, Unemployment Comp, Workers Comp, Dependent and Employee Fee Authorizations



Summary

- On average, faculty and staff salaries are significantly behind market
 - Faculty salaries have significantly slipped compared to benchmarks in recent years
 - Staff salaries lag behind competitive markets and the State of Ohio
- OSU financial support for Graduate Associates is among the lowest for our benchmarks, particularly for health care sponsorship
- Although OSU benefits costs have increased in recent years, they remain competitive with other institutions

(APPENDIX XLI)

AUTHORIZATION FOR CAPITAL PROJECTS

Project	Approved Amount	Funding Source	Requested Action
Animal Science - Roof Replacement	\$.350M	State: \$.350M	Enter into design contract
Baker System - Elevator Modernization	\$.375M	State: \$.375M	Enter into design contract
Fisher & Gerlach Halls – Door & Jamb Replacement	\$.140M	State: \$.140M	Enter into design contract
Hitchcock Hall - North Entrance Improvements	\$.250M	State: \$.250M	Enter into design contract
Hopkins Hall - Elevator Replacement	\$.200M	State: \$.200M	Enter into design contract
Hopkins Hall – Mechanical System Improvements	\$.500M	State: \$.500M	Enter into design contract
McCracken Power Plant – Internal Drainage System	\$.225M	State: \$.225M	Enter into design contract
McCracken Power Plant – Metering Upgrade	\$.250M	State: \$.250M	Enter into design contract
McCracken Power Plant – Spill Control	\$.300M	State: \$.300M	Enter into design contract
Postle Hall – Fire Alarm Replacement	\$.300M	State: \$.300M	Enter into design contract
West Campus Chilled Water Upgrade & Scott Hall Chilled Water Replacement	\$1.000M	State: \$1.000M	Enter into design contract
Football Practice Field #3	\$.318M	Dept.: \$.318M	Enter into construction contracts
Laundry Building Renovation	\$.863M	Dept.: \$.863M	Enter into construction contracts
MacQuigg Lab Chiller Installation	\$.050M	State: \$.050M	Enter into construction contracts
Ohio Stadium Turf Replacement	\$.207M	Dept.: \$.207M	Enter into construction contracts
Total By Source		Dept.: \$1.389M State: \$3.940M	
Total	\$5.329M	\$5.329M	



Animal Science - Roof Replacement

315-2003-932

Requesting Agency(s): PHYSICAL FACILITIES

Location(s): ANIMAL SCIENCE BUILDING

Gross Sq. Ft. 55,857 **Age:** 1960

Description: The 42 year old built-up roof on Animal Science Building would be completely removed down to the metal deck, including removal of 2" of fiberglass insulation. New tapered polyisocyanurate insulation would be installed after any needed metal deck repairs or replacements were completed. A new modified bitumen membrane would be installed with a 20 year warranty requested. (29,125 sq ft & 1,760 l ft copper flashing)

Project Team:

Project Information:

Facility Planner: Is Unassigned
Project Captain: Brett Garrett
Project Assistant: Lisa Baldwin
 (baldwin.10@osu.edu)
Field Coordinator: Is Unassigned

Source of Funds:	Original	Revised	Uses of Funds:	As Designed	As Bid	Completion
HB675 Columbus Basic	\$350,000.00	\$350,000.00				
Renovation			Total:			
Total:	\$350,000.00	\$350,000.00				

Schedule:	Projected	Revised	Actual
Planning			
Arch/Engr Approved by B/T (\$350,000 Project)	05/02/2003		

Animal Science - Roof Replacement

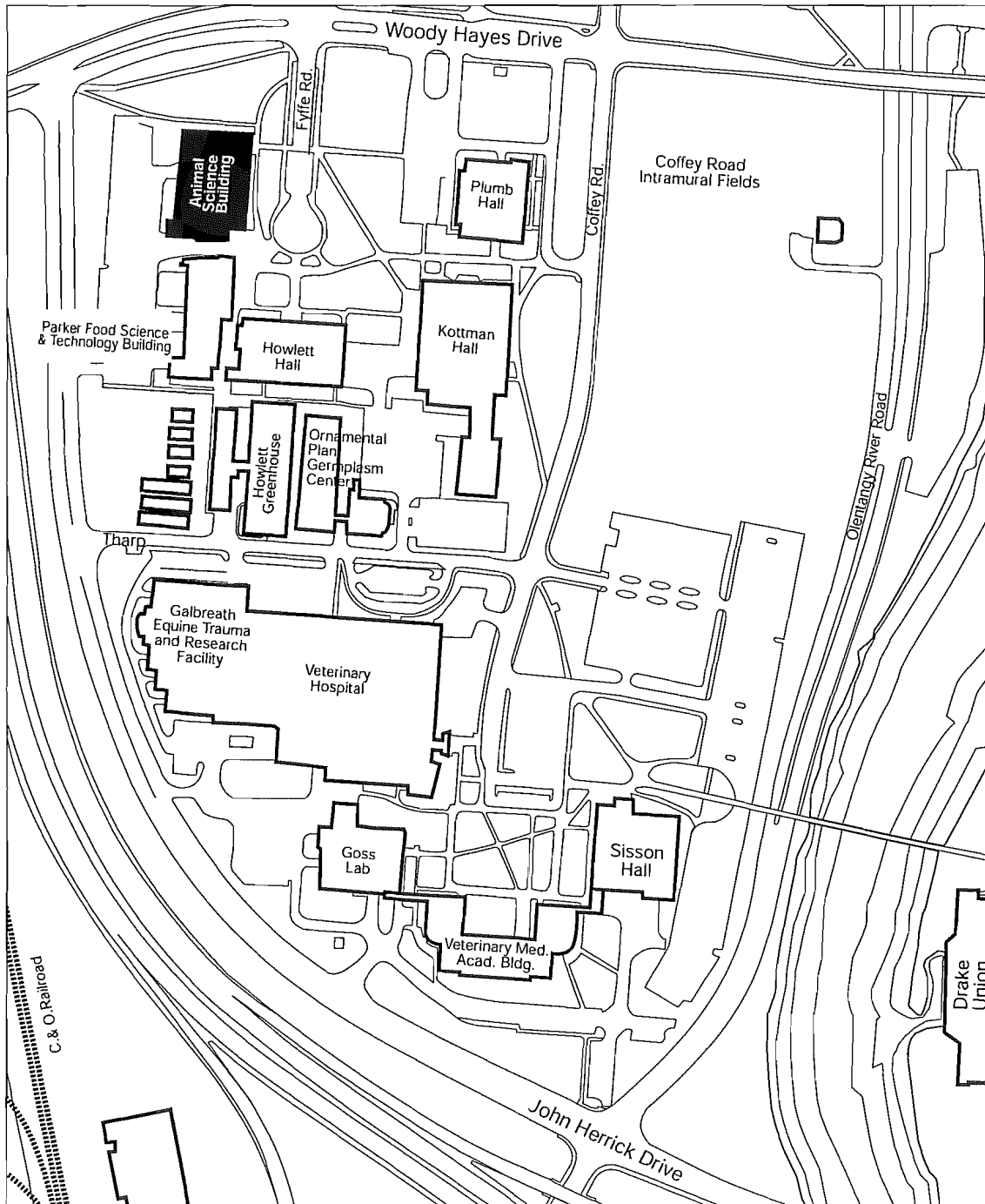

Office of Business and Finance
Office of Facilities Planning and Development

March 13, 2003



Baker Systems - Elevator Modernization

315-2003-937

Requesting Agency(s): PHYSICAL FACILITIES

Location(s): BAKER SYSTEMS ENGINEERING, DAVID F

Gross Sq. Ft. 115,361 **Age:** 1968

Description: Upgrade the three elevators in Baker Systems, which were installed in 1968 to today's codes and standards. The modernization would eliminate the motor generator and relay logic and replace it with variable voltage, variable frequency AC machine and drive. The elevator cab would be upgraded with new plastic laminated wall panels, egg crate ceiling, vinyl tile floor and new car operating panel at handicapped height. The present door operator tracks, hangers and rollers would be replaced and all hoistway doors would be fitted with unlocking devices. The elevator machine room electrical service would need to be upgraded and air conditioned.

Project Team:

Project Information:

Facility Planner: Is Unassigned

Project Captain: Sam Alabi
(alabi.1@osu.edu)

Project Assistant: Lisa Baldwin
(baldwin.10@osu.edu)

Field Coordinator: Is Unassigned

Source of Funds:	Original	Revised	Uses of Funds:	As Designed	As Bid	Completion
HB675 Columbus Basic Renovation	\$375,000.00	\$375,000.00	Total:			
Total:	\$375,000.00	\$375,000.00				

Schedule:	Projected	Revised	Actual
Planning Arch/Engr Approved by B/T (\$375,000 Project)	05/02/2003		

Baker Systems - Elevator Modernization

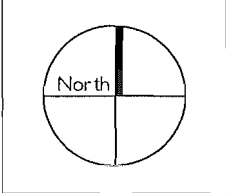
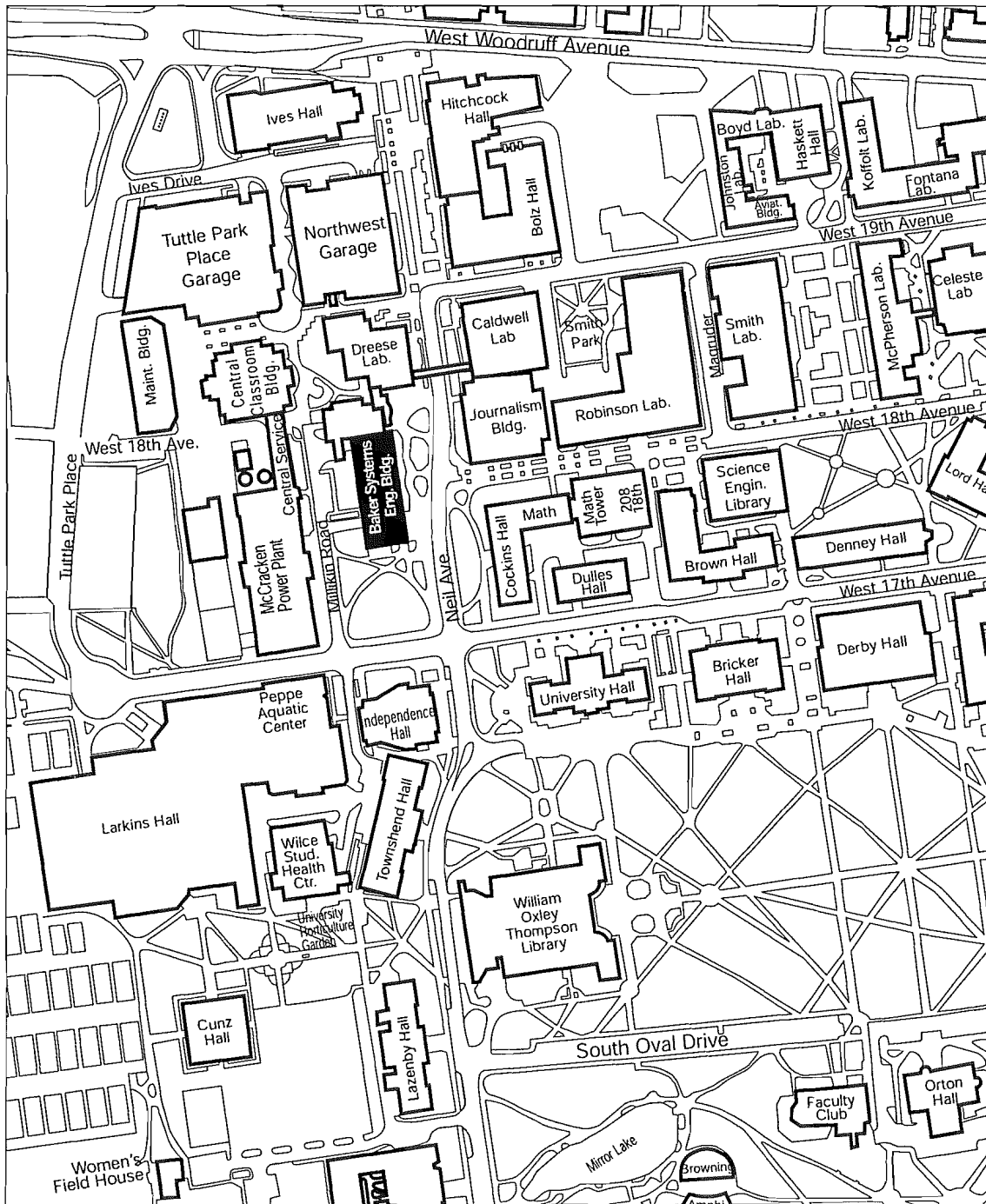

Office of Business and Finance
Office of Facilities Planning and Development

March 13, 2003



Fisher & Gerlach Halls - Door & Jamb Replacement

315-2003-909

Requesting Agency(s): PHYSICAL FACILITIES

Location(s): FISHER HALL, MAX M

Gross Sq. Ft. 132,574 Age: 1998

Location(s): GERLACH GRADUATE PROGRAMS BLDG, J
B

Gross Sq. Ft. 68,621 Age: 1998

Description: High volume of use and specialty doors has resulted in above average wear and tear on the jambs, hinges, handicap operators, and overhead closers for both Fisher and Gerlach Halls.

Project Team:

Project Information:

Facility Planner: Is Unassigned
 Project Captain: Brett Garrett
 Project Assistant: Lisa Baldwin
 (baldwin.10@osu.edu)
 Field Coordinator: Is Unassigned

Source of Funds:	Original	Revised	Uses of Funds:	As Designed	As Bid	Completion
HB675 Columbus Basic	\$140,000.00	\$140,000.00				
Renovation			Total:			
Total:	\$140,000.00	\$140,000.00				

Schedule:	Projected	Revised	Actual
Planning			
Arch/Engr Approved by B/T (\$140,000 Project)	04/04/2003		

Fisher & Gerlach Halls - Door & Jamb Replacement

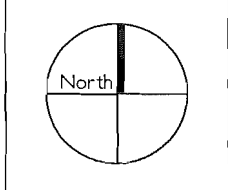
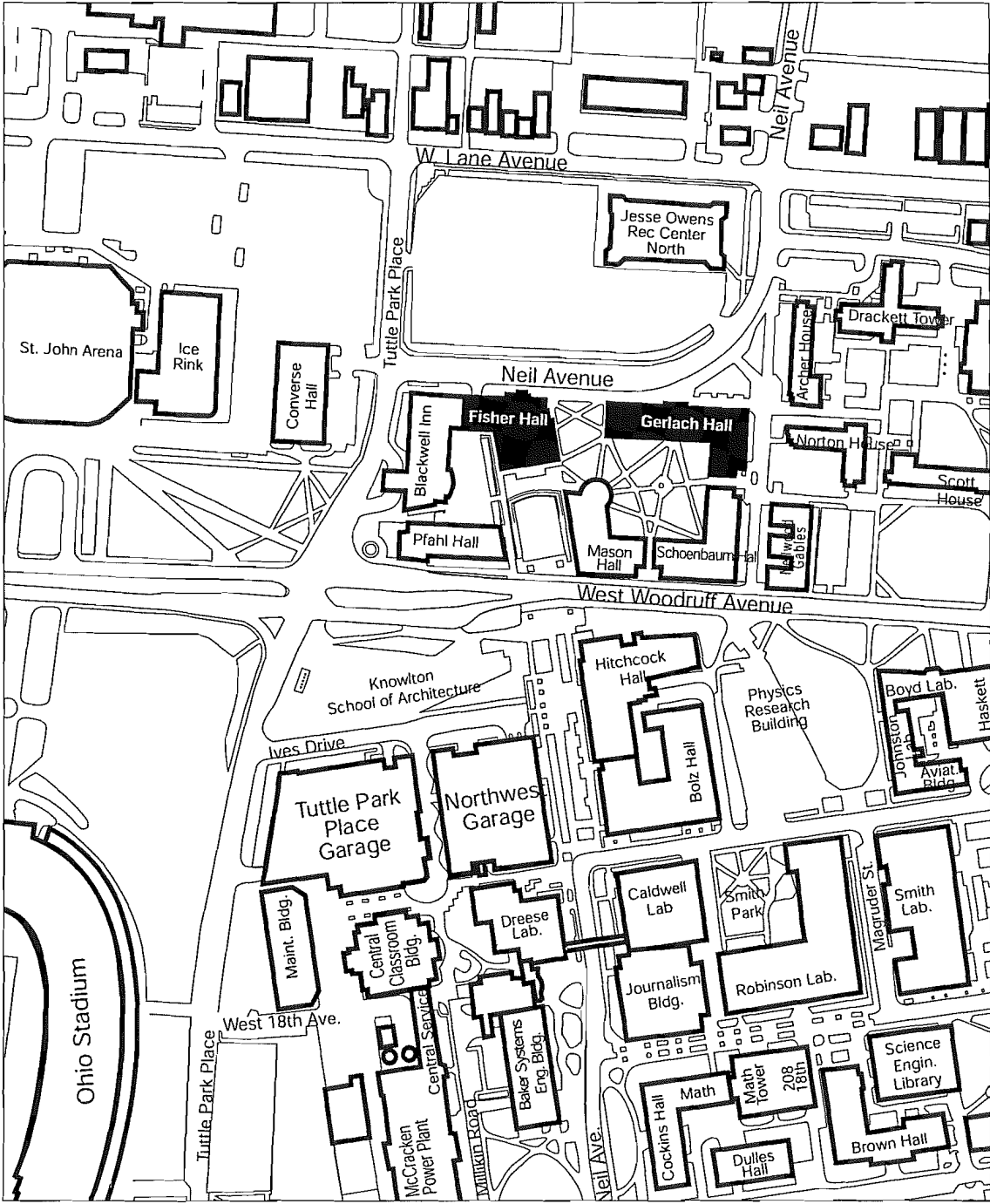

Office of Business and Finance
Office of Facilities Planning and Development

March 13, 2003



Hitchcock Hall - North Entrance Improvements
315-2003-916

Requesting Agency(s): PHYSICAL FACILITIES

Location(s): HITCHCOCK HALL, EMBURY A.

Gross Sq. Ft. 119,498 Age: 1967

Description: This doorway was designed to be an emergency exit only, but is in constant use due to its proximity to the main lecture halls in this building. Interior and exterior improvements at north entrance of Hitchcock Hall from Woodruff Vestibule, door hardware, pavement, lawn, and sidewalk.

Project Team:

Facility Planner: Is Unassigned

Project Captain: Gary Collier
(collier.26@osu.edu)

Project Assistant: Karen Cogley
(cogley.1@osu.edu)

Field Coordinator: Is Unassigned

Project Information:

Source of Funds:	Original	Revised	Uses of Funds:	As Designed	As Bid	Completion
HB675 Columbus Basic	\$250,000.00	\$250,000.00				
Renovation			Total:			
Total:	\$250,000.00	\$250,000.00				

Schedule:

	Projected	Revised	Actual
Planning			
Arch/Engr Approved by B/T (\$250,000 Project)	04/04/2003		



Hopkins Hall - Elevator Replacement

315-2003-911

Requesting Agency(s): PHYSICAL FACILITIES

Location(s): HOPKINS HALL, JAMES R.

Gross Sq. Ft. 108,554 Age: 1959

Description: The elevator in Hopkins Hall was installed in the late 1950s and is unreliable. The present elevator shaft is large enough to accommodate a modern elevator with fire service, ADA features and at least 250 feet per minute or greater speed. The elevator machine room will all require modification to upgrade the electrical service and install air conditioning.

Project Team:

Facility Planner: Is Unassigned
 Project Captain: Sam Alabi
 (alabi.1@osu.edu)
 Project Assistant: Karen Cogley
 (cogley.1@osu.edu)
 Field Coordinator: Is Unassigned

Project Information:

Source of Funds:	Original	Revised	Uses of Funds:	As Designed	As Bid	Completion
HB675 Columbus Basic	\$200,000.00	\$200,000.00				
Renovation			Total:			
Total:	\$200,000.00	\$200,000.00				

Schedule:	Projected	Revised	Actual
Planning			
Arch/Engr Approved by B/T (\$200,000 Project)	04/04/2003		

Hopkins Hall - Elevator Replacement

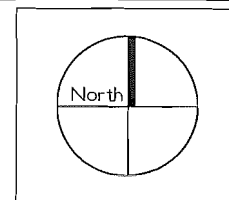
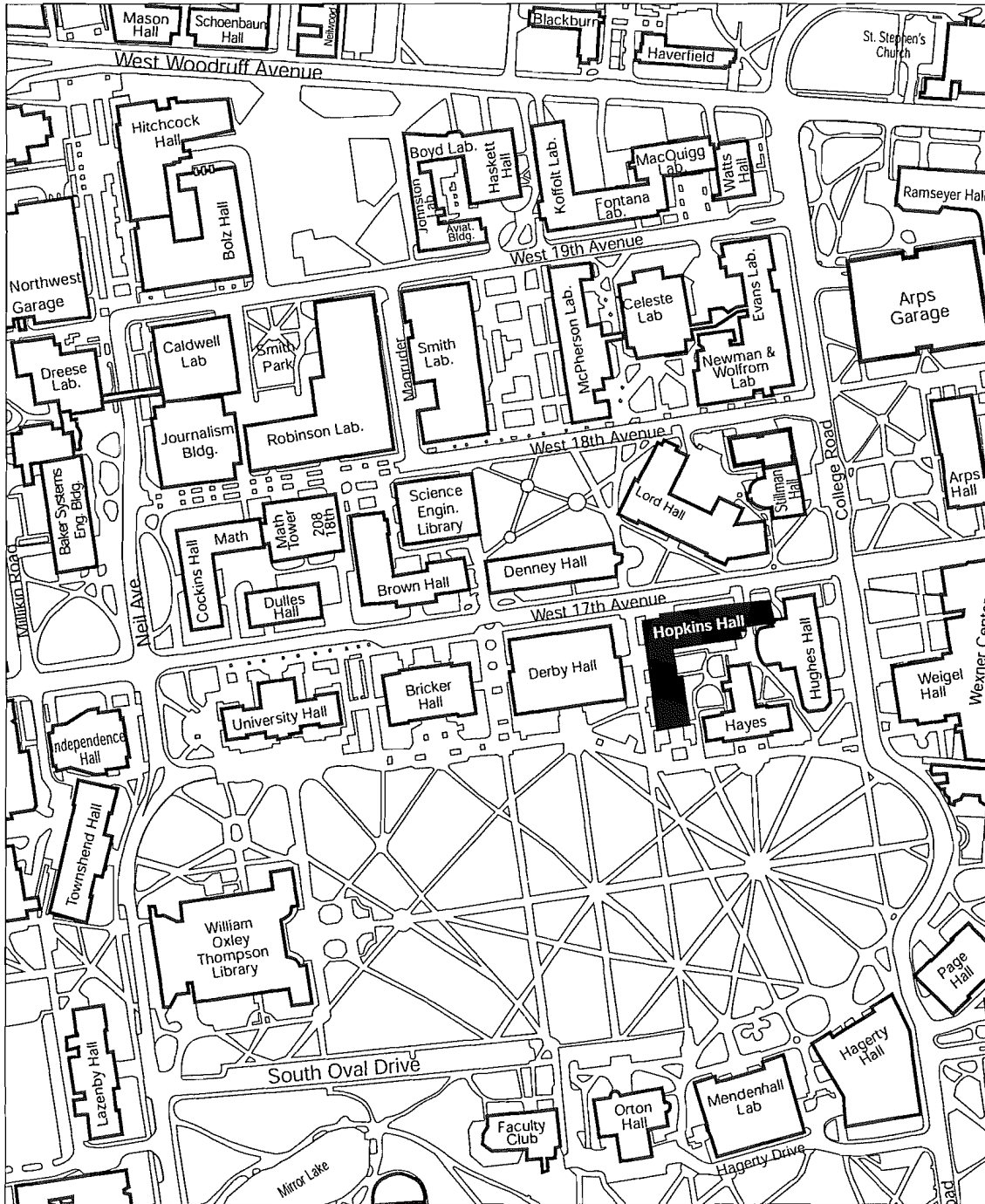

Office of Business and Finance
Office of Facilities Planning and Development

March 13, 2003



Hopkins Hall - Mechanical System Improvements
315-2003-923

Requesting Agency(s): PHYSICAL FACILITIES

Location(s): HOPKINS HALL, JAMES R.

Gross Sq. Ft. 108,554 Age: 1959

Description: Replace the four dual duct heating/ventilating air handling units, dual direct heating/ventilating boxes and ducts in Hopkins Hall. Size the units for present and future capacities.

Project Team:

Facility Planner: Is Unassigned

Project Captain: Larry Hunt
(hunt.183@osu.edu)

Project Assistant: Karen Cogley
(cogley.1@osu.edu)

Field Coordinator: Is Unassigned

Project Information:

Source of Funds:	Original	Revised	Uses of Funds:	As Designed	As Bid	Completion
HB675 Columbus Basic	\$500,000.00	\$500,000.00				
Renovation			Total:			
Total:	\$500,000.00	\$500,000.00				

Schedule:	Projected	Revised	Actual
Planning			
Arch/Engr Approved by B/T (\$500,000 Project)	04/04/2003		

Hopkins Hall - Mechanical System Improvements

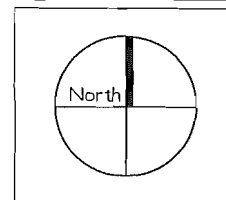
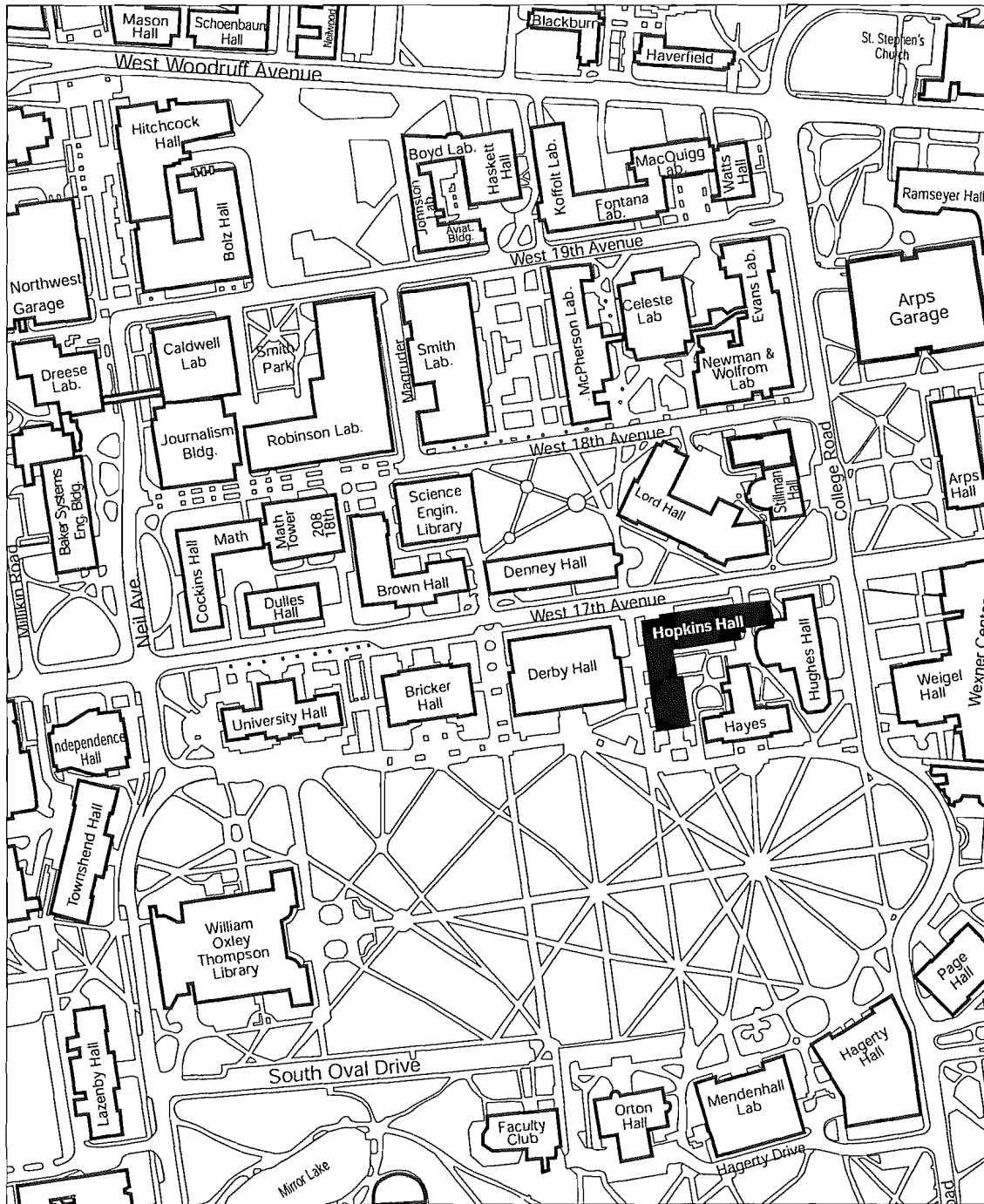

Office of Business and Finance
Office of Facilities Planning and Development

March 13, 2003



McCracken Power Plant - Internal Drainage System

315-2003-927

Requesting Agency(s): PHYSICAL FACILITIES

Location(s): MCCRACKEN POWER PLANT, WILLIAM C

Gross Sq. Ft. 107,910 **Age:** 1918

Description: The original drainage system (circa 1914) is no longer serviceable or in compliance with EPA requirements. This project would rehabilitate the system and meet controls requirements. As it exists, any oil spill within the plant will drain into the storm system then into the Olentangy River. Even the few drains that might drain into the sanitary sewer would present a problem.

Project Team:

Project Information:

Facility Planner: Is Unassigned

Project Captain: Stuart Brace
(brace.2@osu.edu)

Project Assistant: Lisa Baldwin
(baldwin.10@osu.edu)

Field Coordinator: Is Unassigned

Source of Funds:	Original	Revised	Uses of Funds:	As Designed	As Bid	Completion
HB675 Columbus Basic	\$225,000.00	\$225,000.00				
Renovation			Total:			
Total:	\$225,000.00	\$225,000.00				

Schedule:	Projected	Revised	Actual
Planning			
Arch/Engr Approved by B/T (\$225,000 Project)	04/04/2003		

McCracken Power Plant - Internal Drainage System

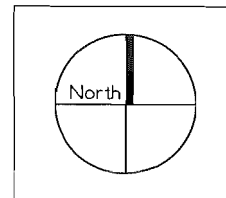
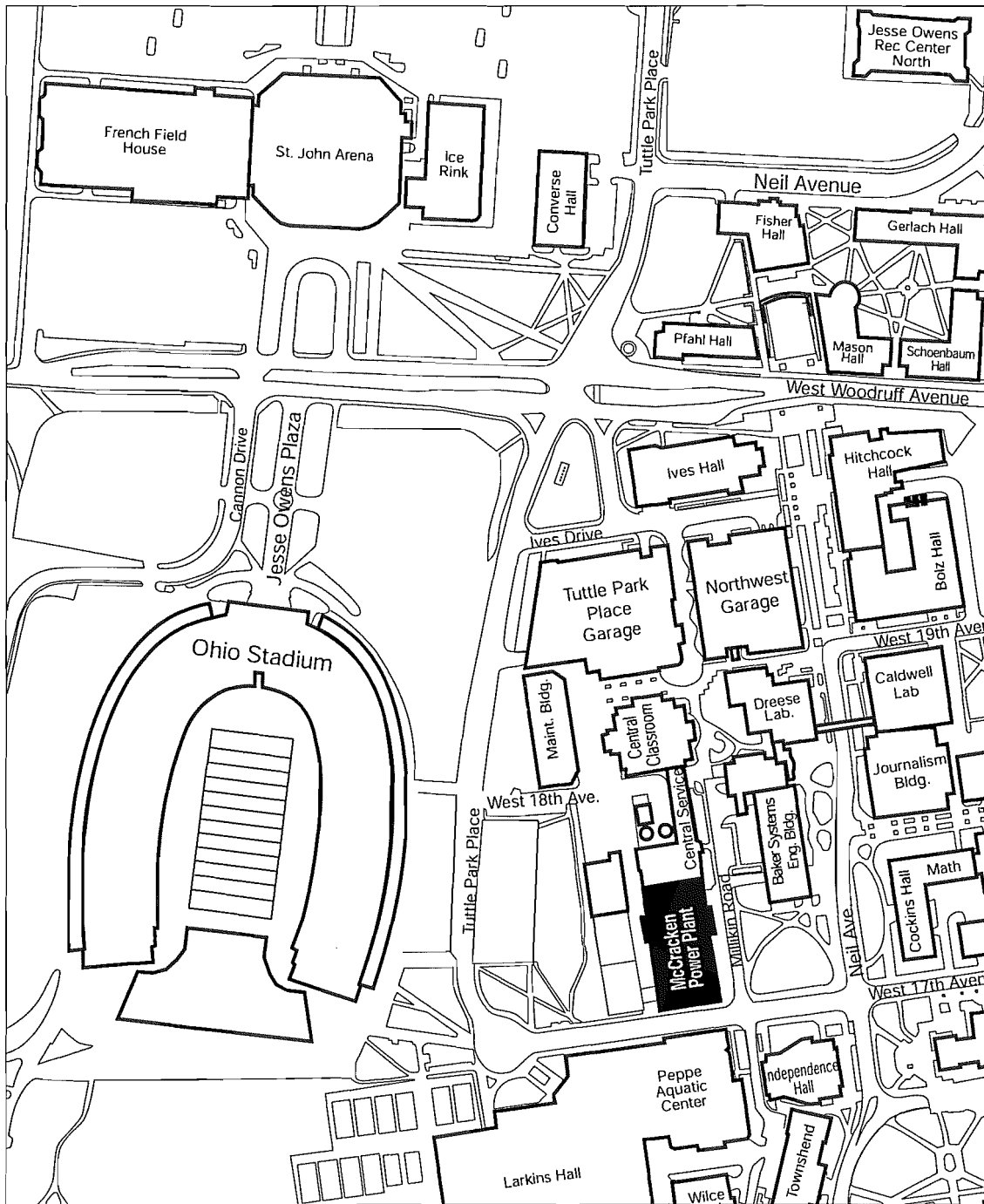

Office of Business and Finance
Office of Facilities Planning and Development

March 13, 2003



McCracken Power Plant - Metering Upgrade
315-2003-926

Requesting Agency(s): PHYSICAL FACILITIES

Location(s): MCCRACKEN POWER PLANT, WILLIAM C

Gross Sq. Ft.107,910 Age: 1918

Description: Existing fuel, steam, water and environmental compliance metering has aged to the point of being unreliable and non-repeatable. This project would selectively replace those meters critical to operations and emissions compliance for the Plant. As approved, the McCracken Power Plant Emissions Compliance project does not cover these meters. This project would also address failure to comply with NFPA 8501 issues identified by the safety audit required by Ohio Administrative Code, 2002.

Project Team:

Facility Planner: Is Unassigned

Project Captain: Sam Alabi
(alabi.1@osu.edu)

Project Assistant: Karen Cogley
(cogley.1@osu.edu)

Field Coordinator: Is Unassigned

Project Information:

Source of Funds:	Original	Revised	Uses of Funds:	As Designed	As Bid	Completion
HB675 Columbus Basic	\$250,000.00	\$250,000.00				
Renovation			Total:			
Total:	\$250,000.00	\$250,000.00				

Schedule:

Planning

Arch/Engr Approved by B/T (\$250,000 Project)

Projected

04/04/2003

Revised

Actual

McCracken Power Plant - Metering Upgrade

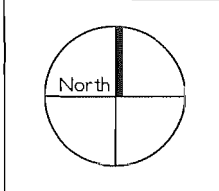
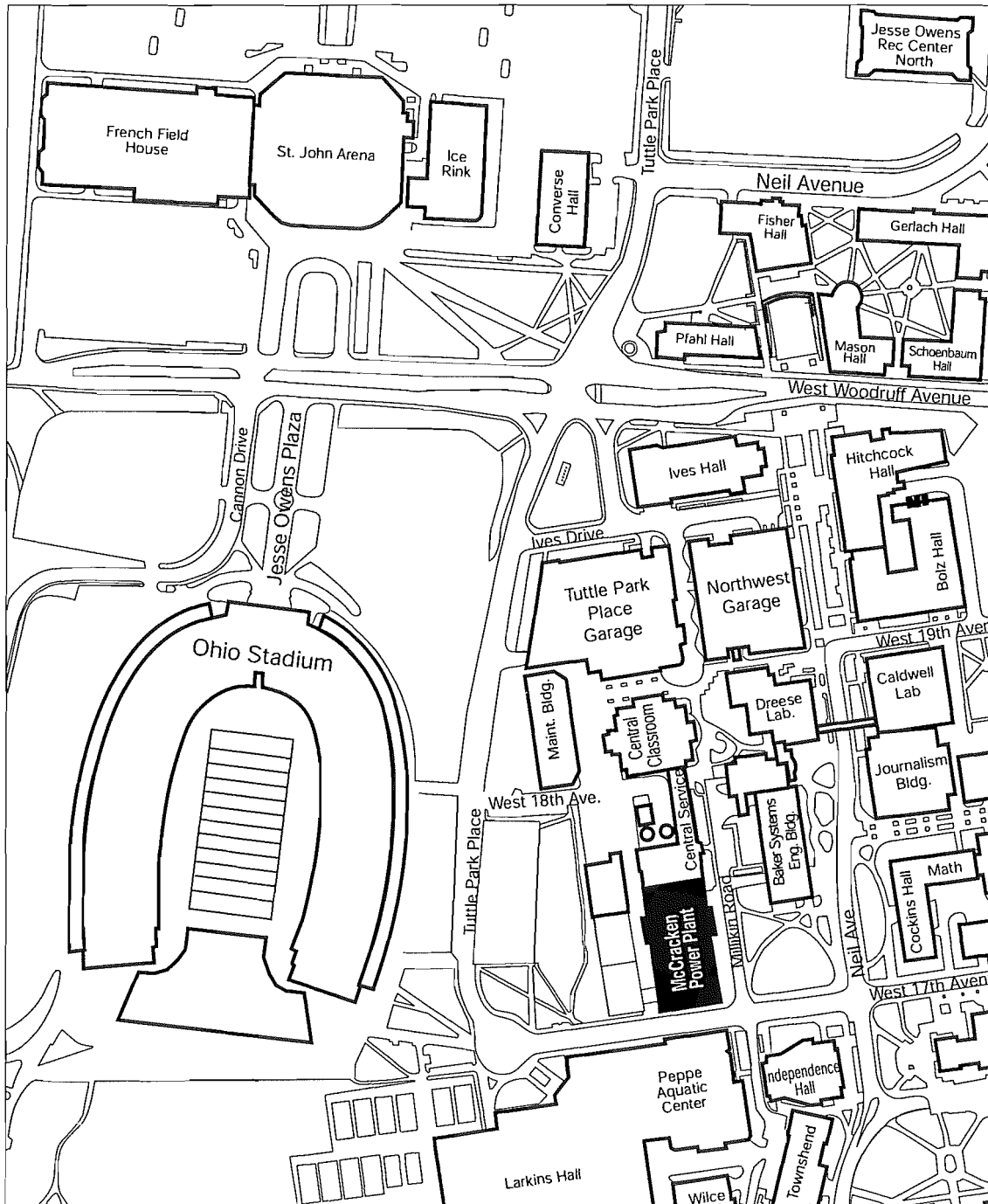

Office of Business and Finance
Office of Facilities Planning and Development

March 13, 2003



Requesting Agency(s): PHYSICAL FACILITIES

Location(s): MCCRACKEN POWER PLANT, WILLIAM C

Gross Sq. Ft. 107,910 Age: 1918

Description: The existing fuel oil tank farm drainage is not protected from fugitive emissions should a tank or pipe fail. Spilled oil would drain into the Olentangy River. This project would provide adequate containment / storm water removal to meet EPA requirements.

Project Team:

Project Information:

Facility Planner: Is Unassigned

Project Captain: Stuart Brace
(brace.2@osu.edu)
Project Assistant: Lisa Baldwin
(baldwin.10@osu.edu)
Field Coordinator: Is Unassigned

Source of Funds:	Original	Revised	Uses of Funds:	As Designed	As Bid	Completion
HB675 Columbus Basic	\$300,000.00	\$300,000.00				
Renovation			Total:			
Total:	\$300,000.00	\$300,000.00				

Schedule:	Projected	Revised	Actual
Planning			
Arch/Engr Approved by B/T (\$300,000 Project)	04/04/2003		

McCracken Power Plant - Spill Control

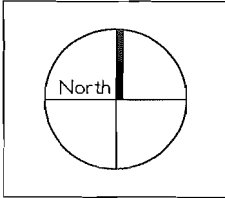
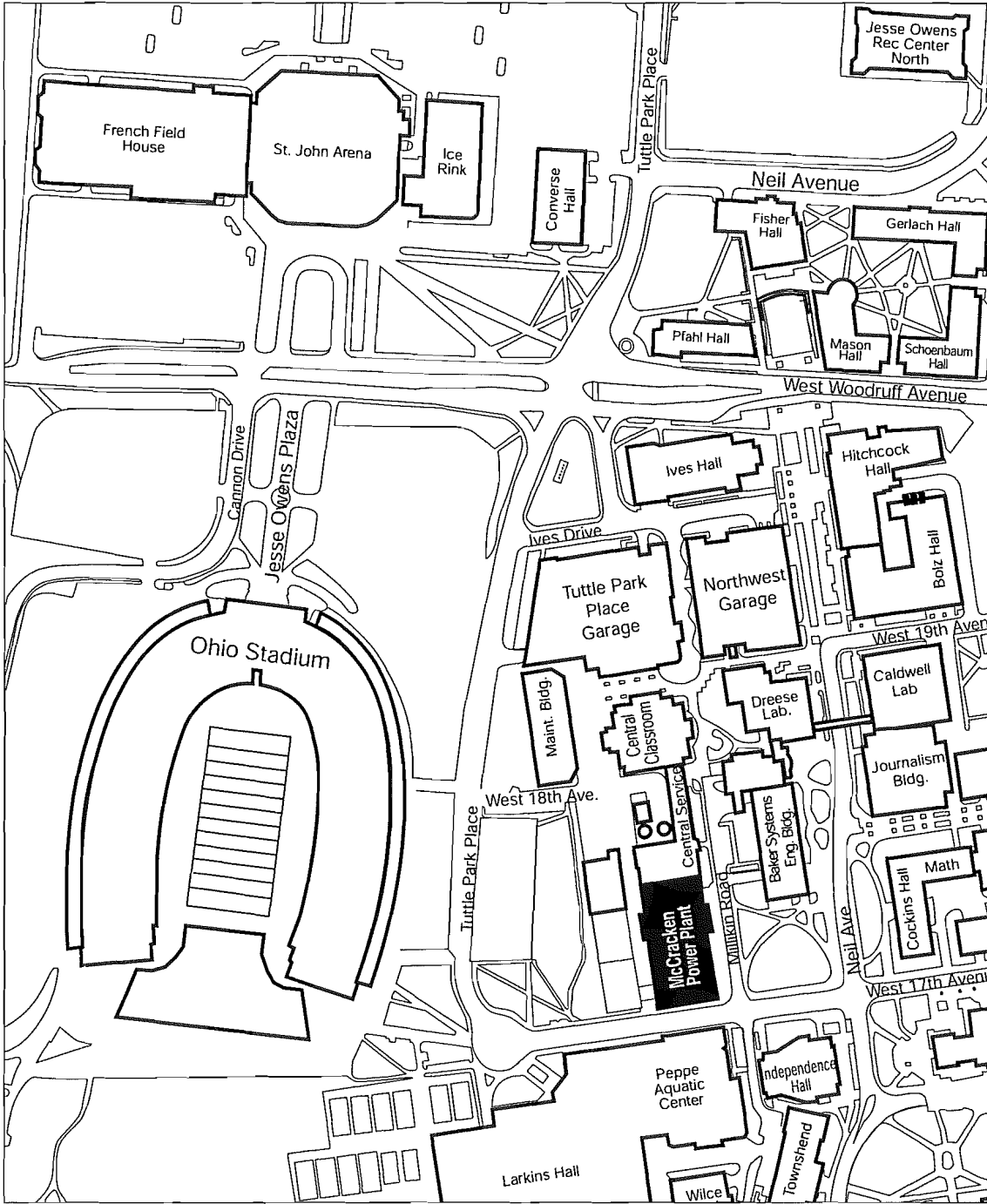

Office of Business and Finance
Office of Facilities Planning and Development

March 13, 2003



Postle Hall - Fire Alarm Replacement
315-2003-915

Requesting Agency(s): PHYSICAL FACILITIES

Location(s): POSTLE HALL, WENDELL D.

Gross Sq. Ft.278,169 **Age:** 1950

Description: Replacement of main panel and devices as necessary to meet code and provide coverage.

Project Team:

Project Information:

Facility Planner: Is Unassigned

Project Captain: Bob Wajnryb
(wajnryb.1@osu.edu)

Project Assistant: Karen Cogley
(cogley.1@osu.edu)

Field Coordinator: Is Unassigned

Source of Funds:	Original	Revised	Uses of Funds:	As Designed	As Bid	Completion
HB675 Columbus Basic	\$300,000.00	\$300,000.00				
Renovation			Total:			
Total:	\$300,000.00	\$300,000.00				

Schedule:	Projected	Revised	Actual
Planning			
Arch/Engr Approved by B/T (\$300,000 Project)	04/04/2003		

Postle Hall - Fire Alarm Replacement

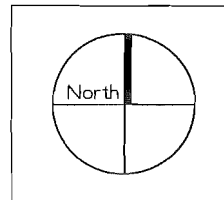
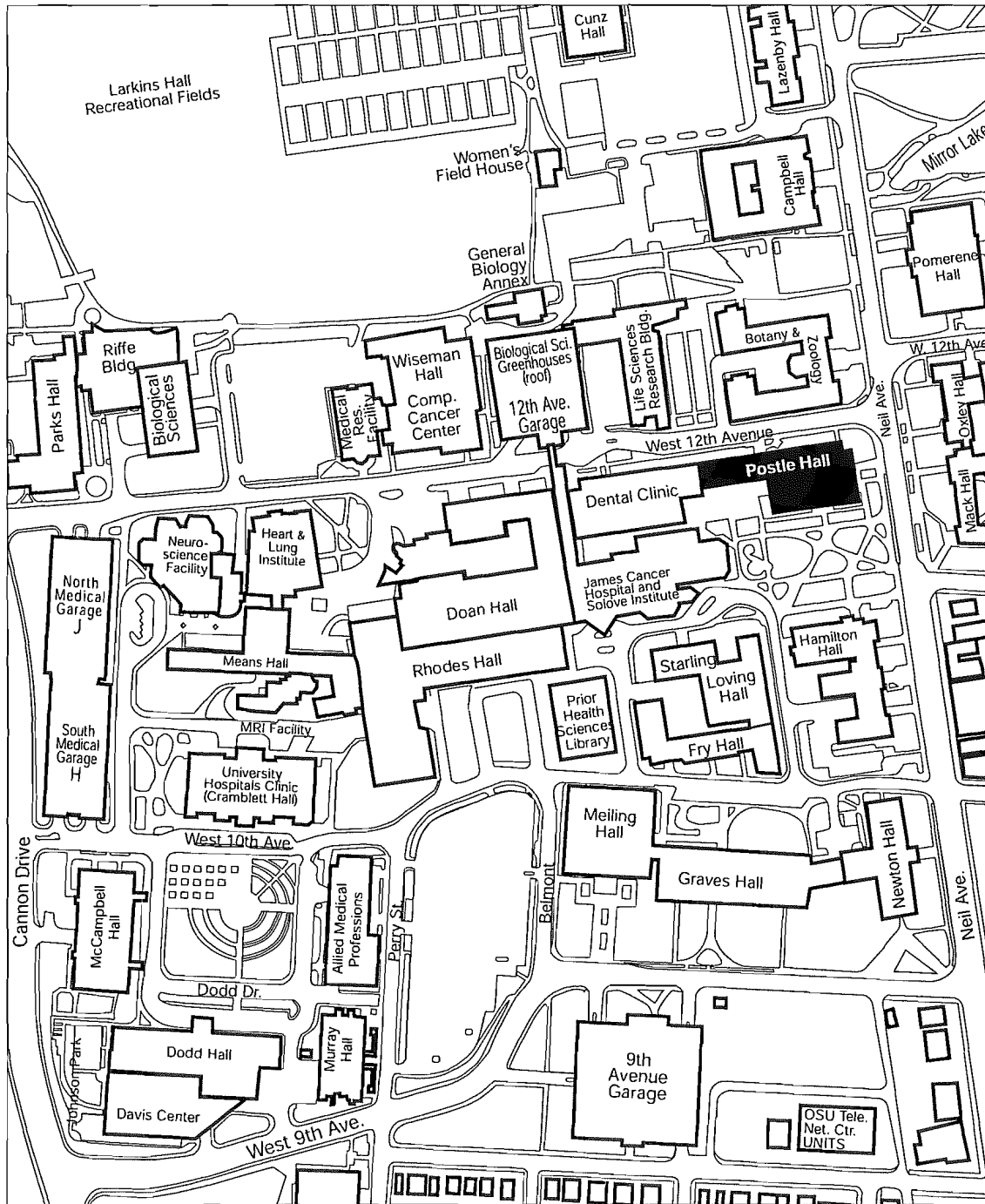

Office of Business and Finance
Office of Facilities Planning and Development

March 13, 2003



West Campus Chilled Water Upgrade & Scott Hall Chiller Repl.

315-2003-924

Requesting Agency(s): PHYSICAL FACILITIES

Location(s): RIGHTMIRE HALL, GEORGE W.

Gross Sq. Ft.97,671 Age: 1969

Location(s): PRESSEY HALL, SIDNEY L.

Gross Sq. Ft.77,825 Age: 1971

Location(s): SCOTT HALL, WILLIAM H

Gross Sq. Ft.58,109 Age: 1972

Description: Improve HVAC cooling to buildings connected to the West Campus chilled water loop. Add/replace chillers connected to the loop, increase reliability of the loop, provide redundant cooling at Pressey Hall, and interconnect Rightmire chillers and Rightmire HVAC loads as equal partners on the loop. Chiller replacement in Scott Hall.

Project Team:

Project Information:

Facility Planner: Is Unassigned

Project Captain: Larry Hunt
(hunt.183@osu.edu)

Project Assistant: Lisa Baldwin
(baldwin.10@osu.edu)

Field Coordinator: Is Unassigned

Source of Funds:	Original	Revised	Uses of Funds:	As Designed	As Bid	Completion
HB675 Columbus Basic Renovation	\$1,000,000.00	\$1,000,000.00				
Total:	\$1,000,000.00	\$1,000,000.00	Total:			

Schedule:	Projected	Revised	Actual
Planning Arch/Engr Approved by B/T (\$1,000,000 Project)	04/04/2003		

West Campus Chilled Water Upgrade & Scott Hall Chilled Water Replacement

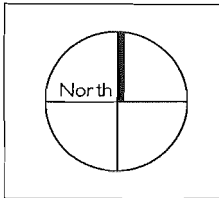
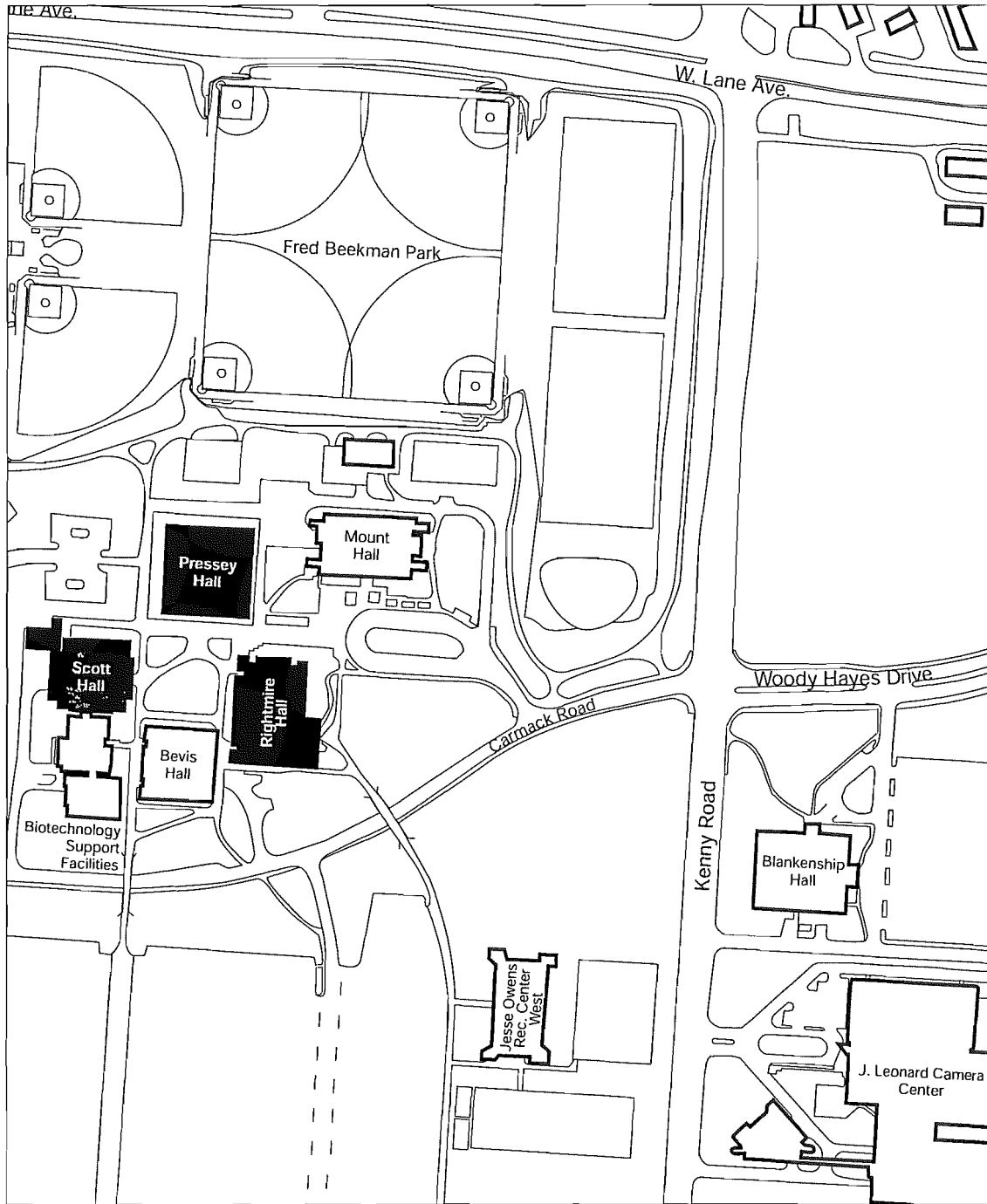

Office of Business and Finance
Office of Facilities Planning and Development

March 13, 2003



Football Practice Field #3

50700-R031715

Requesting Agency(s): ATHLETICS

Location(s): Site - See Comments.

Gross Sq. Ft.0 Age:

Description: Reconstruct the natural turf on football field #3 with new generation stabilizer mat and seeded with premium blend of perennial ryegrass. OFP # 03-19

Project Team:

Project Information:

Facility Planner: Is Unassigned

Project Captain: Thomas Heretta
(heretta.1@osu.edu)

Project Assistant: Curt Handschug
(handschug.1@osu.edu)

Field Coordinator: Is Unassigned

Source of Funds:	Original	Revised	Uses of Funds:	As Designed	As Bid	Completion
Auxiliaries-Athletics	\$318,175.00	\$318,175.00	Construction	\$275,000.00		\$0.00
			Contingency	\$27,500.00		\$0.00
Total:	\$318,175.00	\$318,175.00	Design	\$9,900.00		\$0.00
			Local Administration	\$5,775.00		\$0.00
			Total:	\$318,175.00		\$0.00

Schedule:	Projected	Revised	Actual
Planning			
Bidding Approved B/T	04/04/2003		
Bidding			
Bid Opening	04/15/2003		
Construction			
Award of Contracts	04/27/2003		
Completion	06/10/2003		
Report of Award to B/T	12/05/2003		

Football Practice Field #3

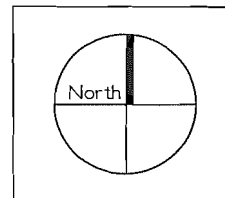
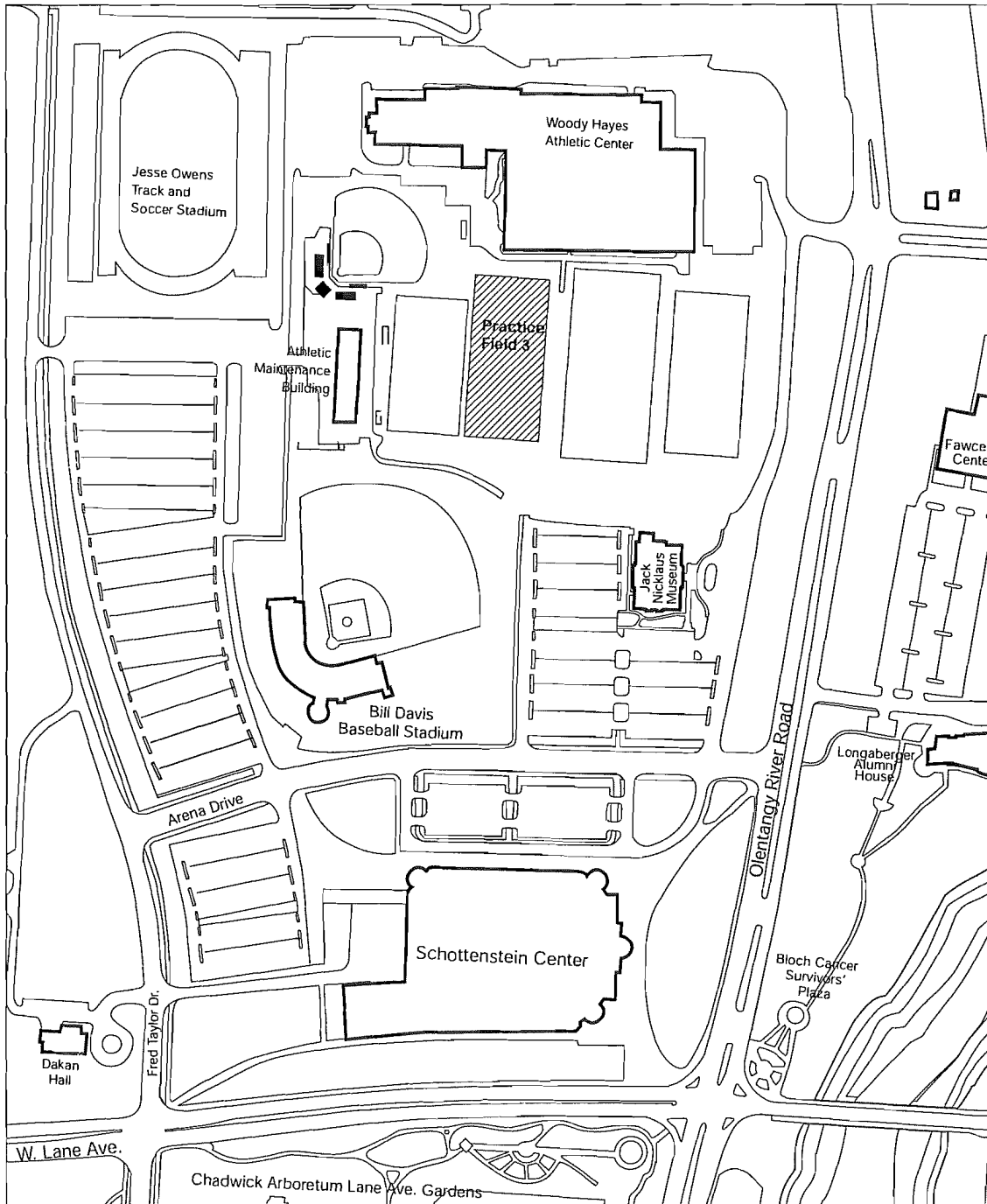

Office of Business and Finance
Office of Facilities Planning and Development

March 13, 2003



Laundry Building Renovation
5062-PF6796

Requesting Agency(s): PHYSICAL FACILITIES

Location(s): LAUNDRY BUILDING

Gross Sq. Ft. 52,993 Age: 1968

Description: Renovation of the Laundry Building as part of the Physical Facilities Shop Relocation.

Project Team:

Project Information:

Facility Planner: Is Unassigned

Project Captain: Bob Wajnryb
(wajnryb.1@osu.edu)

Project Assistant: Is Unassigned

Field Coordinator: Is Unassigned

Source of Funds:	Original	Revised	Uses of Funds:	As Designed	As Bid	Completion
General Funds-Business &	\$713,475.00	\$857,683.00	Construction	\$684,757.00		\$0.00
Admin			Contingency	\$68,476.00		\$0.00
Total:	\$713,475.00	\$857,683.00	Design	\$104,450.00		\$0.00
			Total:	\$857,683.00		\$0.00

Schedule:	Projected	Revised	Actual
Planning			
Bidding Approved B/T (\$857,683 Project)	04/04/2003		
Design			
Construction Document Approval	03/24/2003		
Bidding			
Bid Opening	05/19/2003		
Construction			
Construction Start	07/21/2003		
Report of Award to B/T	12/05/2003		
Completion	12/29/2003		

Laundry Building Renovation

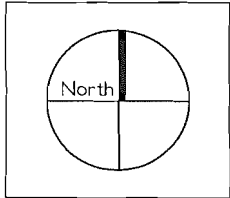

Office of Business and Finance
Office of Facilities Planning and Development

March 13, 2003



Requesting Agency(s): RESEARCH, OFFICE OF

Location(s): MACQUIGG LABORATORY, CHARLES E.

Gross Sq. Ft.76,810 Age: 1967

Description: Installation of Chiller System for the Sputtering unit located in Room 270.

Project Team:

Facility Planner: Is Unassigned

 Project Captain: Charlie Conner
 (conner.26@osu.edu)
 Project Assistant: Lisa Baldwin
 (baldwin.10@osu.edu)
 Field Coordinator: Is Unassigned

Project Information:

Source of Funds:	Original	Revised	Uses of Funds:	As Designed	As Bid	Completion
BOR Action Fund	\$50,000.00	\$50,000.00	Construction	\$44,850.00		\$0.00
			Contingency	\$4,477.25		\$0.00
Total:	\$50,000.00	\$50,000.00	Local Administration	\$672.75		\$0.00
			Total:	\$50,000.00		\$0.00

Schedule:

	Projected	Revised	Actual
Planning			
Bidding Approved B/T	04/04/2003		
Bidding			
Bid Opening	04/17/2003		
Construction			
Award of Contracts	06/15/2003		
Construction Start	06/16/2003		
Completion	10/14/2003		
Report of Award to B/T	12/05/2003		

MacQuigg Lab - Chiller Installation

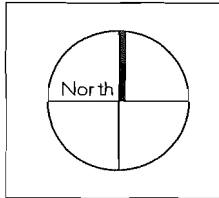
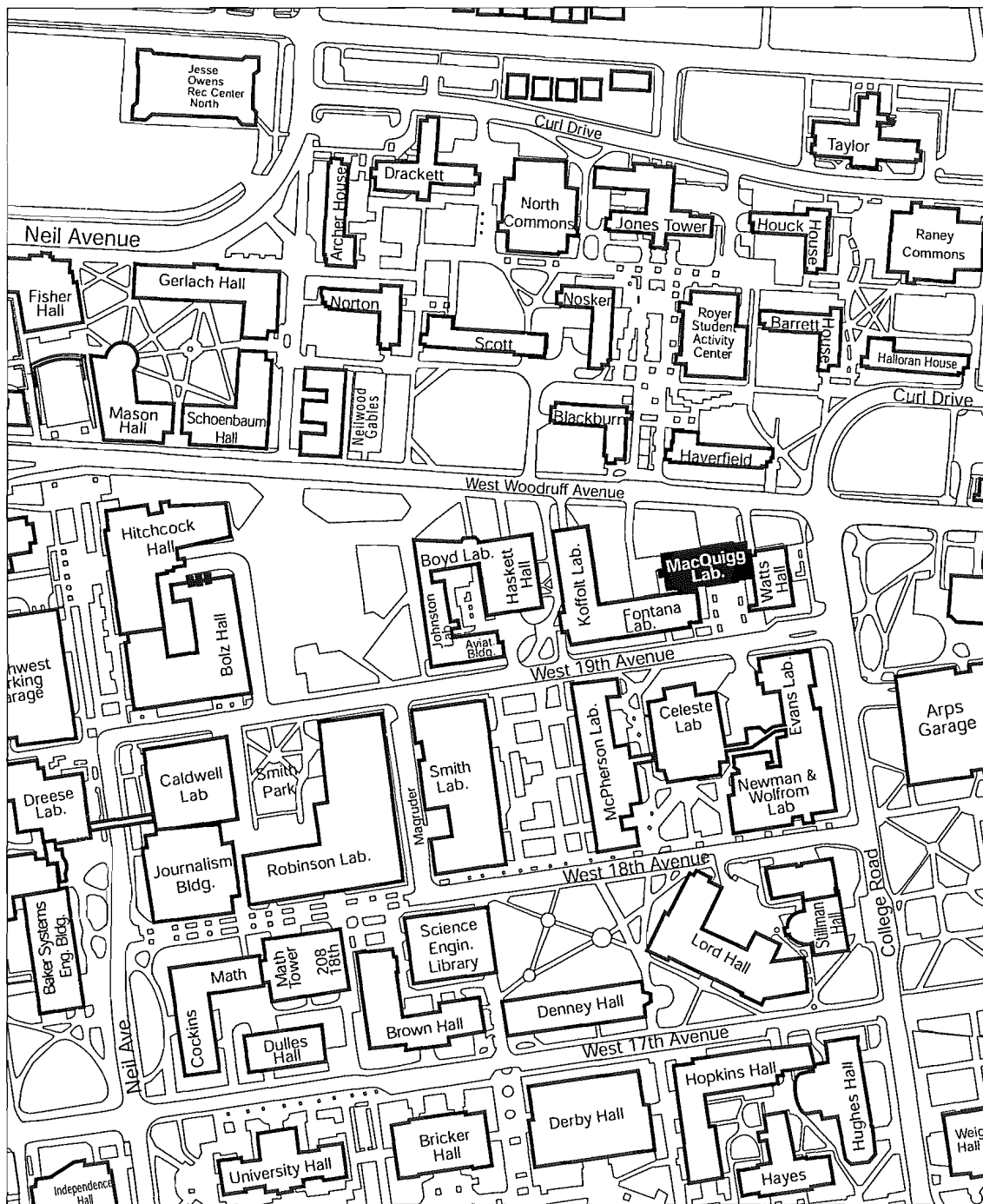

Office of Business and Finance
Office of Facilities Planning and Development

March 13, 2003



Ohio Stadium - Turf Replacement
50700-R031716

Requesting Agency(s): ATHLETICS

Location(s): OHIO STADIUM

Gross Sq. Ft. 812,422 Age: 1922

Description: Replace the stabilized bluegrass turf in the football stadium with new generation stabilizer mat and seeded with a premium blend of perennial ryegrass.

OPF # 03-20

Project Team:

Facility Planner: Is Unassigned

Project Captain: Thomas Heretta
(heretta.1@osu.edu)

Project Assistant: Curt Handschug
(handschug.1@osu.edu)

Field Coordinator: Is Unassigned

Project Information:

Should the grass seed fail to become viable for football by August 18th, the Contractor must install fully mature sod for the first home football game on August 27, 2003.

Source of Funds:	Original	Revised	Uses of Funds:	As Designed	As Bid	Completion
Auxiliaries-Athletics	\$207,125.00	\$207,125.00	Construction	\$175,000.00		\$0.00
			Contingency	\$17,500.00		\$0.00
Total:	\$207,125.00	\$207,125.00	Design	\$9,900.00		\$0.00
			Local Administration	\$4,725.00		\$0.00
			Total:	\$207,125.00		\$0.00

Schedule:	Projected	Revised	Actual
Planning			
Bidding Approved B/T (\$207,125 Project)	04/04/2003		
Bidding			
Bid Opening	04/08/2003		
Construction			
Award of Contracts	04/12/2003		
Construction Start	04/12/2003		
Completion	05/26/2003		
Report of Award to B/T	12/05/2003		

Ohio Stadium - Turf Replacement

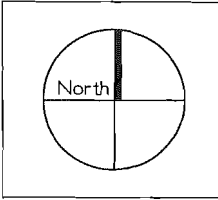
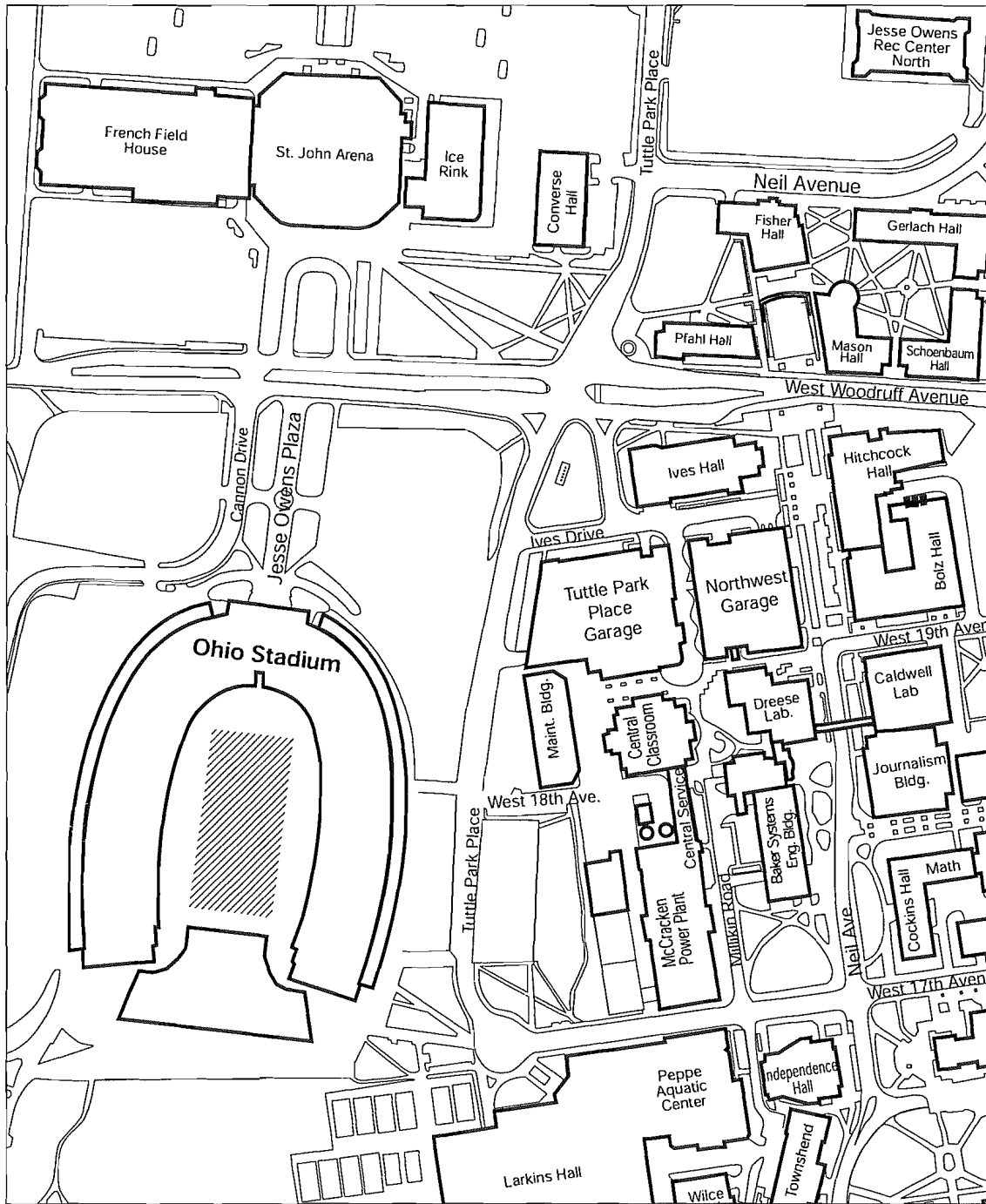

Office of Business and Finance
Office of Facilities Planning and Development

March 13, 2003

Summary of the Mansfield Campus Master Plan

Introduction

The Mansfield Campus Master Plan establishes a framework and long-range vision for the future of the Mansfield Campus. It is a working document for the growth, development, and improvement of the campus that provides the planning rationale for decisions regarding the buildings, landscape, infrastructure, circulation, parking, and community interaction. The plan focuses future growth and development, establishes priorities for improving the appearance of campus and provides a basis for determining resource needs and raising funds.

Process

A planning team with representatives from the University, the Mansfield Campus, and the North Central State College guided the development of the plan. The team assisted in the initial inventory and evaluation, and formally reviewed the plan at the first draft/alternatives and final draft/preferred alternative stages. A list of planning team members and an outline of the approval process are attached.

The process began with an inventory and evaluation of existing campus and surrounding community conditions as well as the academic missions and goals of the University, the Mansfield Campus, and North Central State College. Meetings, interviews, and open forums were held to identify planning issues. These issues, along with inventory and evaluation data became the basis for the goals and objectives and a framework for the campus plan.

Alternative plan concepts were developed to examine a variety of solutions for short-term and long-term development of the campus. These alternative plans were presented for input to the planning team and to students, staff, faculty, neighbors and community leaders at open forums. In addition, the plans were made available for review and comment via the web and public display of the plans. From the input received on the alternatives, a recommended plan was developed. This plan was reviewed again in a process similar to that used for the alternatives. The plan was refined and presented for final draft review.

Goals and objectives

The goals for the Mansfield Campus were based on the four general goals established for the Columbus campus master planning process. Several objectives, specific to the Mansfield Campus were developed under each of these goals.

Campus Master Plan Goal: *Conserve the University's finite resources.*

Objectives

- Develop a land use plan to establish priorities and strategies for campus development.
- Identify locations for future facilities and programmed outdoor space expansion.
- Identify open space reserve areas necessary to preserve the campus image.
- Identify potential areas on campus for outside development.

Campus Master Plan Goal: *Unify and Integrate Campus Development.*

Objectives

- Improve pedestrian and vehicular circulation on campus
- Identify and locate future building uses and sites
- Improve the use of existing campus facilities.

Campus Master Plan Goal: *Improve the quality of the Campus environment through a long-range commitment to strong design principles.*

Objectives

- Establish an identity for the campus and the individual institutions
- Provide Design Guidelines to unify the campus appearance.
- Ensure accessibility
- Maintain and improve the passive and active green spaces on campus
- Improve the campus landscaping

Campus Master Plan Goal: *Strengthen linkages with the community*

Objectives

- Encourage the use of walking trails, athletic fields, and other facilities by the surrounding community

- Link the Mansfield campus with the surrounding community, residential areas and business and industry
- Provide walking and bicycle trails to link the campus with the neighborhoods
- Provide attractive, formal entrances to the campus

Recommended Plan

The image of the Mansfield Campus is one of natural beauty with dense, forested areas, significant topography and minimal open areas. This setting tends to make the campus buildings seem isolated from one another. The Mansfield Campus plan improves the connections and views between the buildings and creates a sense of place for the two institutions without destroying the natural, wooded beauty of the campus. To retain as much of the forest as possible, the plan creates several smaller “outdoor rooms” rather than one large, central space. Ovalwood, Bromfield, Eisenhower and a new building site surround the main open space, roughly in the center of the campus. An existing open meadow, to the west of the Physical Activities Center, is partially enclosed by that building, a new building site, and the south loop of a relocated road. These two spaces are linked in front of Ovalwood, and form a green core for primarily University buildings. Another, smaller core is created between Key Hall (formerly NCSC Engineering Center) and Fallerius, buildings predominantly occupied by NCSC programs.

The main road through campus has been reorganized as a loop, with one side accessing primarily University facilities and the other accessing NCSC facilities. Such an organization facilitates the establishment of individual identities for each institution and provides an east west link without interrupting the academic campus. The existing east and west entrances are maintained, but realigned to allow views into the campus, to a new University building site from the east and to the existing NCSC Health Sciences Building from the west.

Improved pedestrian circulation includes new and renovated paths between existing buildings, new building sites and the central parking lot. A new, broad, landscaped pedestrian path bisects the central parking lot, providing some relief to the large expanse of asphalt and a view corridor into the main campus core. The recommended plan also preserves large areas of forested land, providing access to these areas with new and improved trails.

Three areas of undeveloped land along the north, south and west boundaries of the campus are designated for potential future development. These areas are remote from the academic core and separated by natural buffers, so their development, even by outside entities to the benefit of the University, would not alter or degrade the unique qualities of the campus.

The recommended Mansfield Campus Plan provides a strong presence, a sense of place and the potential for growth for both institutions, while strengthening the image of Mansfield Campus as a place of natural beauty.

The Ohio State University Mansfield Campus

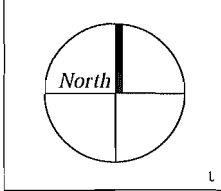
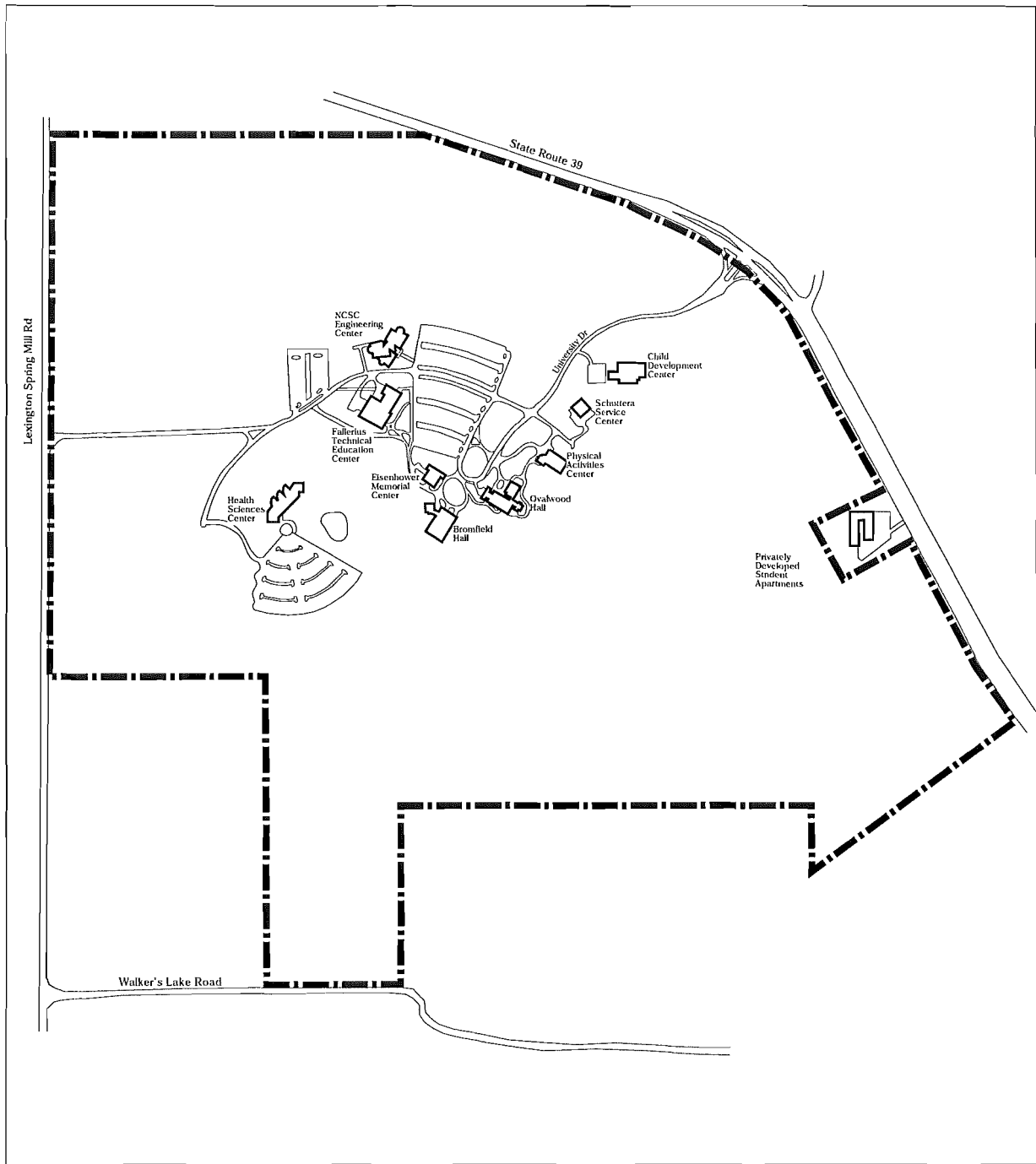

Office of Business and Finance
Office of Facilities Planning and Development

November 9, 2001

Recommended Plan

LEGEND

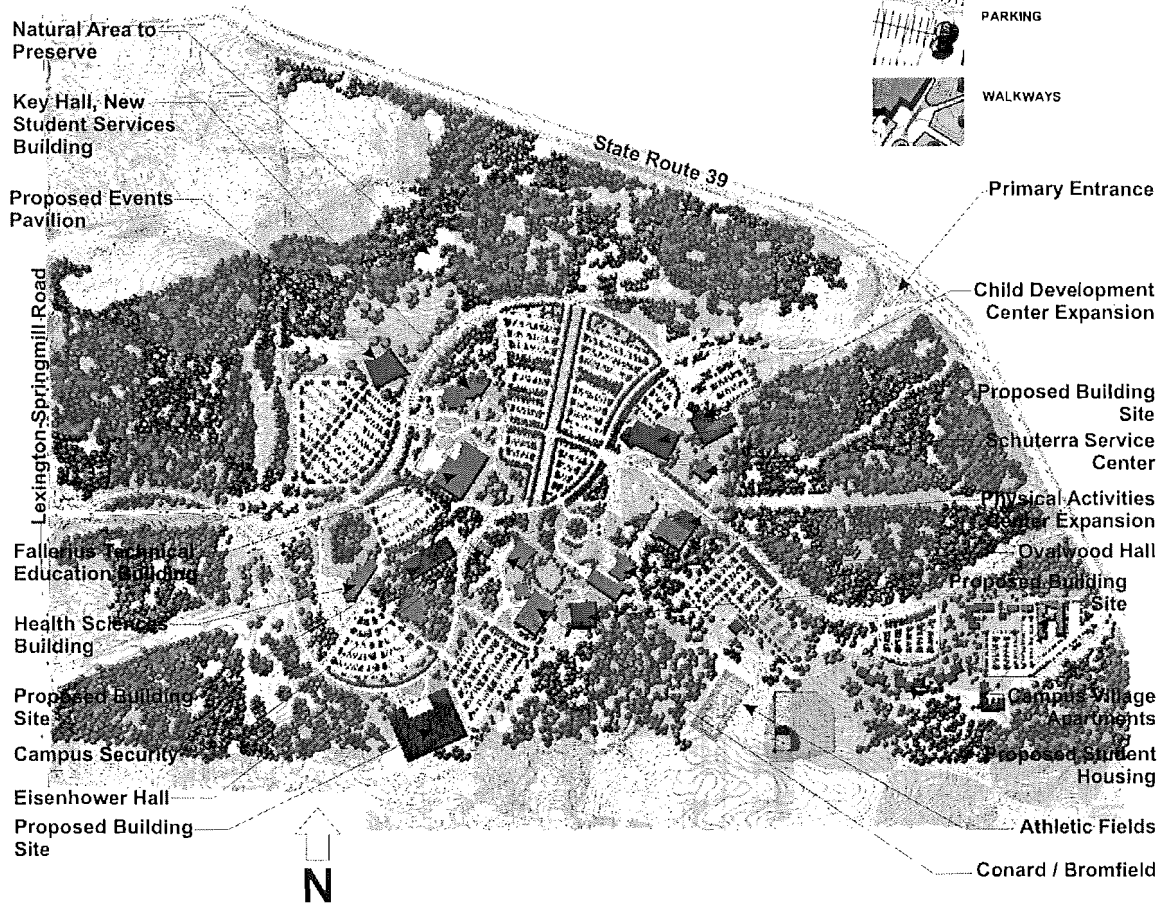
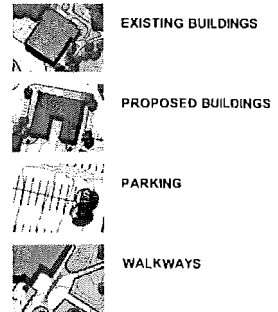

Figure 5-1

The Ohio State University Mansfield
 North Central State College
 MANSFIELD, OHIO

SUMMARY OF THE MARION CAMPUS MASTER PLAN

Introduction

The Marion Campus Master Plan establishes a framework and long-range vision for the future of the Marion Campus. It is a working document for the growth, development, and improvement of the campus that provides the planning rationale for decisions regarding the buildings, landscape, infrastructure, circulation, parking, and community interaction. The plan focuses future growth and development, establishes priorities for improving the appearance of campus and provides a basis for determining resource needs and raising funds.

Process

A planning team with representatives from the University, the Marion Campus, and the Marion Technical College guided the development of the plan. The team assisted in the initial inventory and evaluation, and formally reviewed the plan at the first draft/alternatives and final draft/preferred alternative stages. A list of planning team members and an outline of the approval process are attached.

The process began with an inventory and evaluation of existing campus and surrounding community conditions as well as the academic missions and goals of the University, the Marion Campus, and the Marion Technical College. Meetings, interviews, and open forums were held to identify planning issues. These issues, along with inventory and evaluation data became the basis for the goals and objectives and a framework for the campus plan.

Alternative plan concepts were developed to examine a variety of solutions for short-term and long-term development of the campus while achieving the established master plan goals. These alternative plans were presented for input to the planning team and to students, staff, faculty, neighbors and community leaders at open forums. In addition, the plans were made available for review and comment via the web and public display of the plans. From the input received on the alternatives, a recommended plan was developed. This plan was reviewed again in a process similar to that used for the alternatives. The plan was refined and presented for final draft review.

Goals and objectives

The goals for the Marion Campus were based on the four general goals established for the Columbus campus master planning process. Those goals are:

- Conserve the university's finite resources.
- Unify and integrate campus development.
- Improve the quality of the campus environment by a long-range commitment to strong design principles
- Strengthen linkages with the community.

Six additional goals, specific to the Marion Campus were developed:

- Improve the appearance of campus.
- Plan for the immediate and long-term facility needs of the campus.
- Plan for the long-term future of the campus.
- Improve open spaces throughout the campus.
- Improve circulation on the campus to increase convenience and safety.
- Design parking to increase convenience for commuters and make the most efficient use of limited space.

Recommended Plan

The recommended Marion Regional Campus Master Plan (see figure of recommended plan attached) builds upon the strengths of the existing campus plan, while providing for future growth and improvement. The existing large-scale open space in the center of campus, with its expanse of lawn and pond provides a focal point for the campus. The recommended plan strengthens this space by placing buildings closer together to provide more enclosure to this space. Smaller scale, more intimate spaces are developed between the buildings to provide a hierarchy of open space. This hierarchy, in turn, allows a variety of gathering opportunities both informal and formal, for large or small groups of students, staff and faculty. Proposed academic, administrative, and student service facilities are located inside a loop road. Proposed facilities with a more public role, such as a potential new childcare facility and a nature center associated with an expanded prairie, have been sited outside the loop, but still in close proximity. A student residential complex is located to the south and east of the main core, and is connected to the central green and pond by a vista and walkways. This location provides easy access to the academic core, while creating a sense of community and refuge from study. The student living complex is complemented by recreation facilities located on the east side of the campus. Land to the south is dedicated to open space for passive recreation, educational opportunities such as an expansion of the prairie, and a future land bank for the campus.

A partial loop road exists on campus. This circulation is strengthened to complete the loop, which keeps vehicular traffic away from the core, allowing it to become a pedestrian realm. Parking is organized along the loop road, and is reorganized and increased in order to create a better distribution of parking in close proximity to new facilities. The existing campus entry off of State Route 95 is maintained as a large green lawn which provides a sense of arrival and a relief from the existing, unattractive commercial development along that road. The plan also anticipates a future county road along the west edge of the property by establishing a second entrance from that road. The west road satisfies a local community need for a north to south connector somewhere near the Marion Campus. Locating the road on the west side allows the campus to remain self-contained without separations by major vehicular paths. Proper negotiation of agreements with the county can ensure that control of development is retained along this new entry corridor.

Marion Regional Campus District Study Area

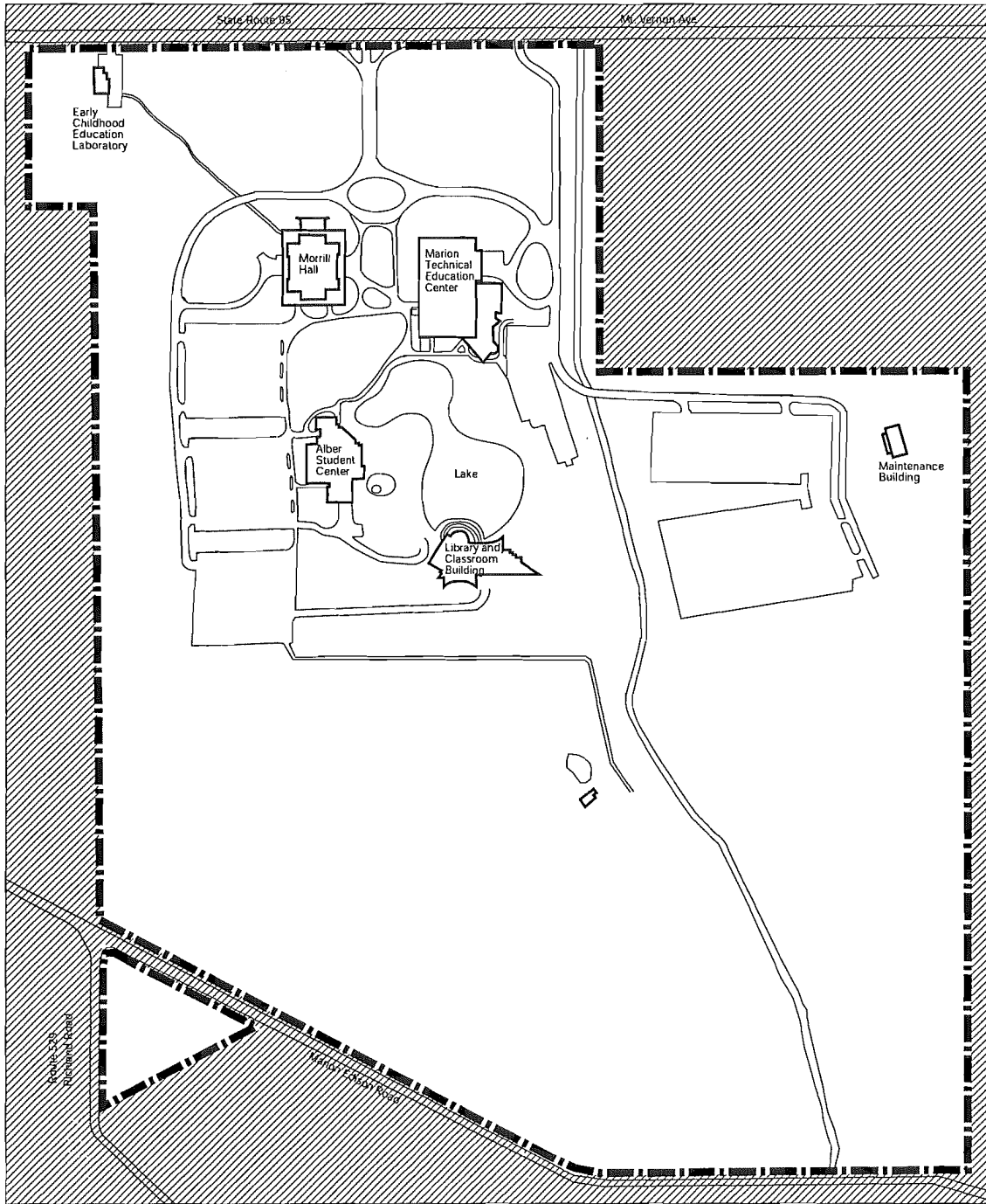

Focus Area



Impact Area

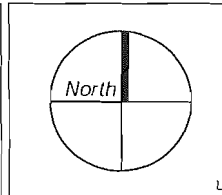





Office of Business and Finance
Office of Facilities Planning and Development

January 7, 2002

Recommended Plan

LEGEND:

-  Existing Building
-  Proposed Building
-  Gathering Area / Plaza Area
-  Roads/Parking

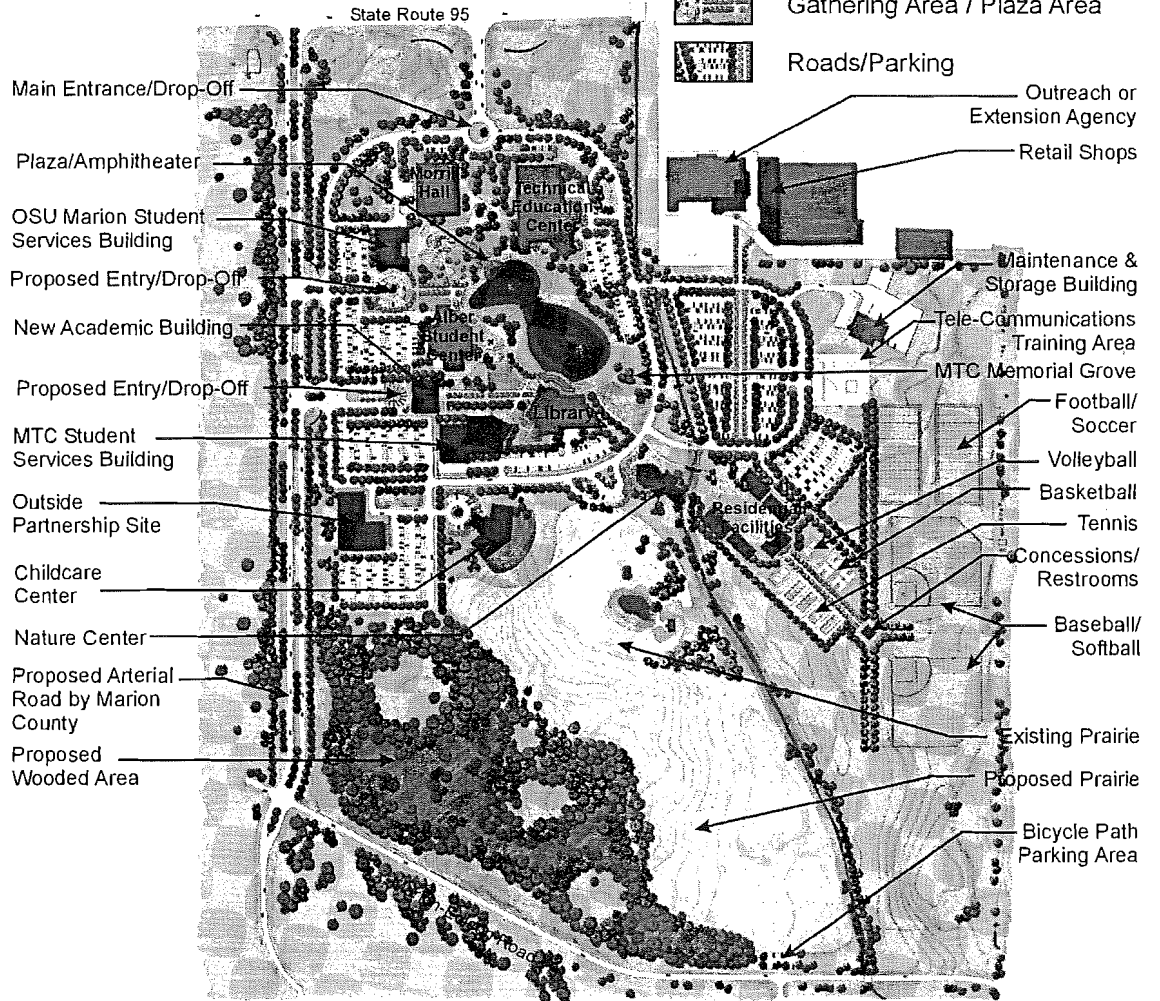

WOOLPERT LLP
 409 EAST MONUMENT AVENUE
 DAYTON, OHIO 45402
 (937) 461-5660
 WOOLPERT <http://www.woolpert.com>

The Ohio State University at Marion
 Marion Technical College
 MARION, OHIO

SUMMARY OF THE NEWARK REGIONAL CAMPUS MASTER PLAN

Introduction

The Newark Regional Campus Master Plan establishes a framework and long-range vision for the future of the Newark Campus. It is a working document for the growth, development, and improvement of the campus that provides the planning rationale for decisions regarding the buildings, landscape, infrastructure, circulation, parking, and community interaction. The plan focuses future growth and development, establishes priorities for improving the appearance of campus and provides a basis for determining resource needs and raising funds.

Process

A planning team with representatives from the University, the Newark Campus, and the Central Ohio Technical College guided the development of the plan. The team assisted in the initial inventory and evaluation, and formally reviewed the plan at the first draft/alternatives and final draft/preferred alternative stages. A list of planning team members and an outline of the approval process are attached.

The process began with an inventory and evaluation of existing campus and surrounding community conditions as well as the academic missions and goals of the University, the Newark Campus, and COTC. Meetings, interviews, and open forums were held to identify planning issues. These issues, along with inventory and evaluation data, became the basis for the goals and objectives and a framework for the campus plan.

Alternative plan concepts were developed to examine a variety of solutions for short-term and long-term development of the campus while achieving the established master plan goals. These alternative plans were presented for input to the planning team and to students, staff, faculty, neighbors and community leaders at open forums. In addition, the plans were made available for review and comment via the web and public display of the plans. From the input received on the alternatives, a recommended plan was developed. This plan was reviewed again in a process similar to that used for the alternatives. The plan was refined and presented for final draft review.

Goals and objectives

The goals for the Newark Campus were based on the four general goals established for the Columbus campus master planning process. Those goals are:

- Conserve the university's finite resources.
- Unify and integrate campus development.
- Improve the quality of the campus environment by a long-range commitment to strong design principles
- Strengthen linkages with the community.

Seven additional goals, specific to the Newark Campus were developed:

- Improve vehicular and pedestrian circulation on campus.
- Identify future building sites.
- Improve the use of existing campus facilities.
- Provide design guidelines.
- Improve accessibility.
- Maintain and improve the green spaces on campus.
- Improve the campus landscape.

Recommended Plan

The recommended Newark Regional Campus Master Plan (see figure 5-1 attached) reinforces and builds on the original vision of the campus as a collection of buildings located around a strong, central, pedestrian-oriented green space. The plan completes the organization of facilities around the central open space and includes proposals for improving campus entrances, vehicular and pedestrian circulation, and parking. The plan recommends a hierarchy of open gathering spaces at building entrances and along an improved pedestrian walkway system throughout the campus.

New academic, student, and administrative facilities recommended by the plan are sited around the central open space to strengthen the sense of enclosure of this space, and provide the campus with a sense of place. The central space of campus will become a pedestrian-oriented area, linked to other exterior spaces, to provide many opportunities for a variety of gatherings, interaction, and informal learning.

Student Affairs has recently purchased and assumed the management of an existing student housing complex located to the northeast of the campus core. Land immediately adjacent to this is owned by the Evans Foundation. The plan recommends that additional University student housing be developed on the Foundation land *should* that land become available. An alternative location for housing is suggested to the south of the existing complex. In both locations, the plan recommends improving pedestrian connections to the core campus and adjacent parkland.

The plan recommends maintaining parking outside the central green, reorganizing and adding to it for a better distribution of spaces and improved circulation, and enhancing it with additional landscaping to more fully integrate the parking areas within the campus setting.

The plan proposes two new primary entrances. One is off Granville Road, with a view to the new Technology/Conference Center (Reese Center) and into the central green beyond. A second future entrance is located to the south along Country Club Road at the intersection with Londondale Drive. This second entrance will require acquisition of a single property and may warrant a traffic signal. Secondary entrances are shown off Country Club Road, one aligned with the entrance to Founders Hall. All of these entrances connect to a perimeter road and a well-defined primary circulation drive through the west parking lots.

Two facilities are proposed outside the loop road: a childcare center, and a new building for facilities management and maintenance. The childcare center is located to provide convenient and safe drop-off and pick-up from the center without moving into the campus core. The facilities management building is relocated to free up a prime location on the central green more suited to an academic, student service or administrative use. A location outside the loop will also provide easy access for maintenance vehicles and opportunities for adequate screening for outdoor storage.

Newark Regional Campus District Study Area

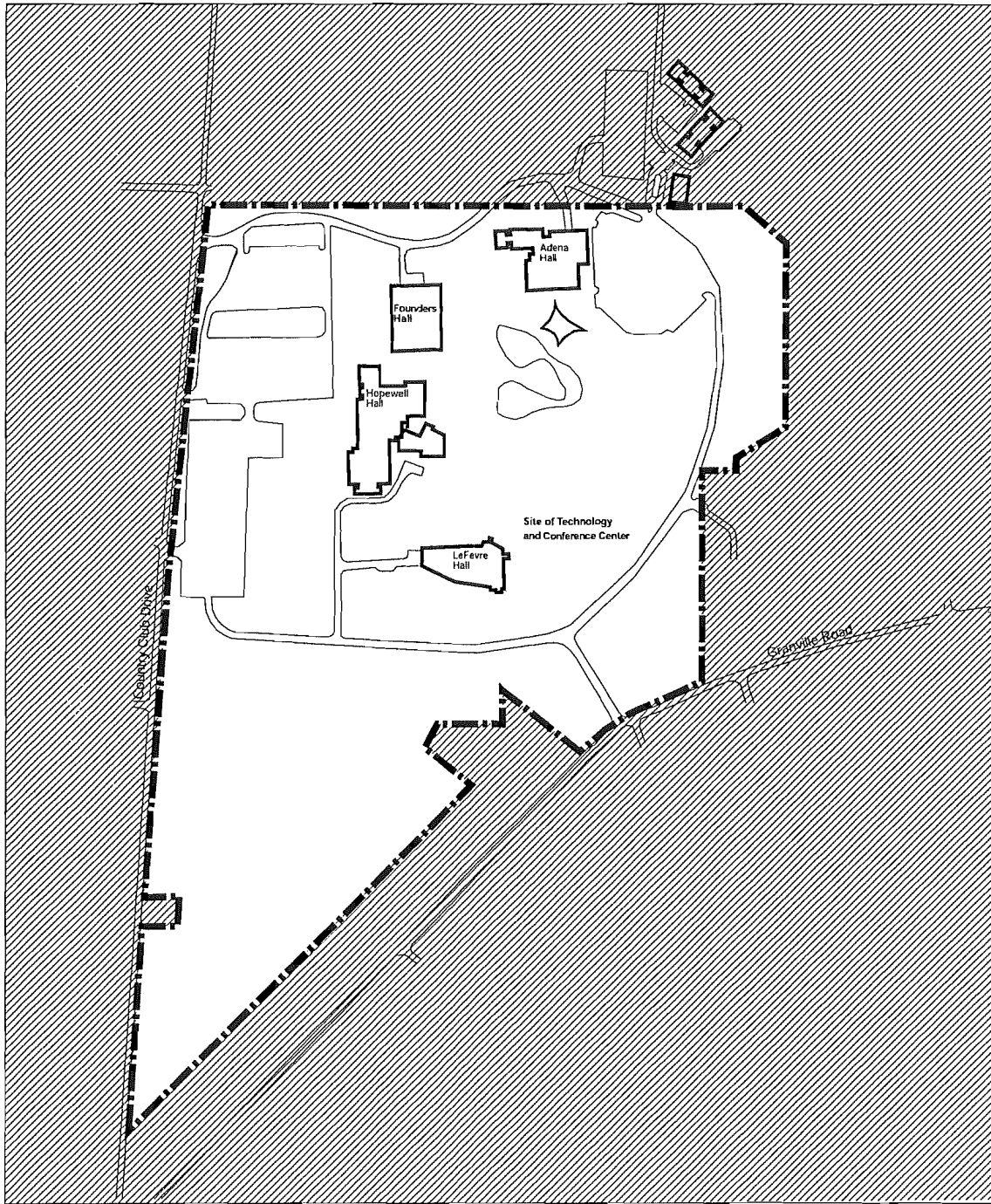

Focus Area



Impact Area

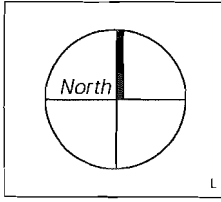

Office of Business and Finance
Office of Facilities Planning and Development

November 9, 2001

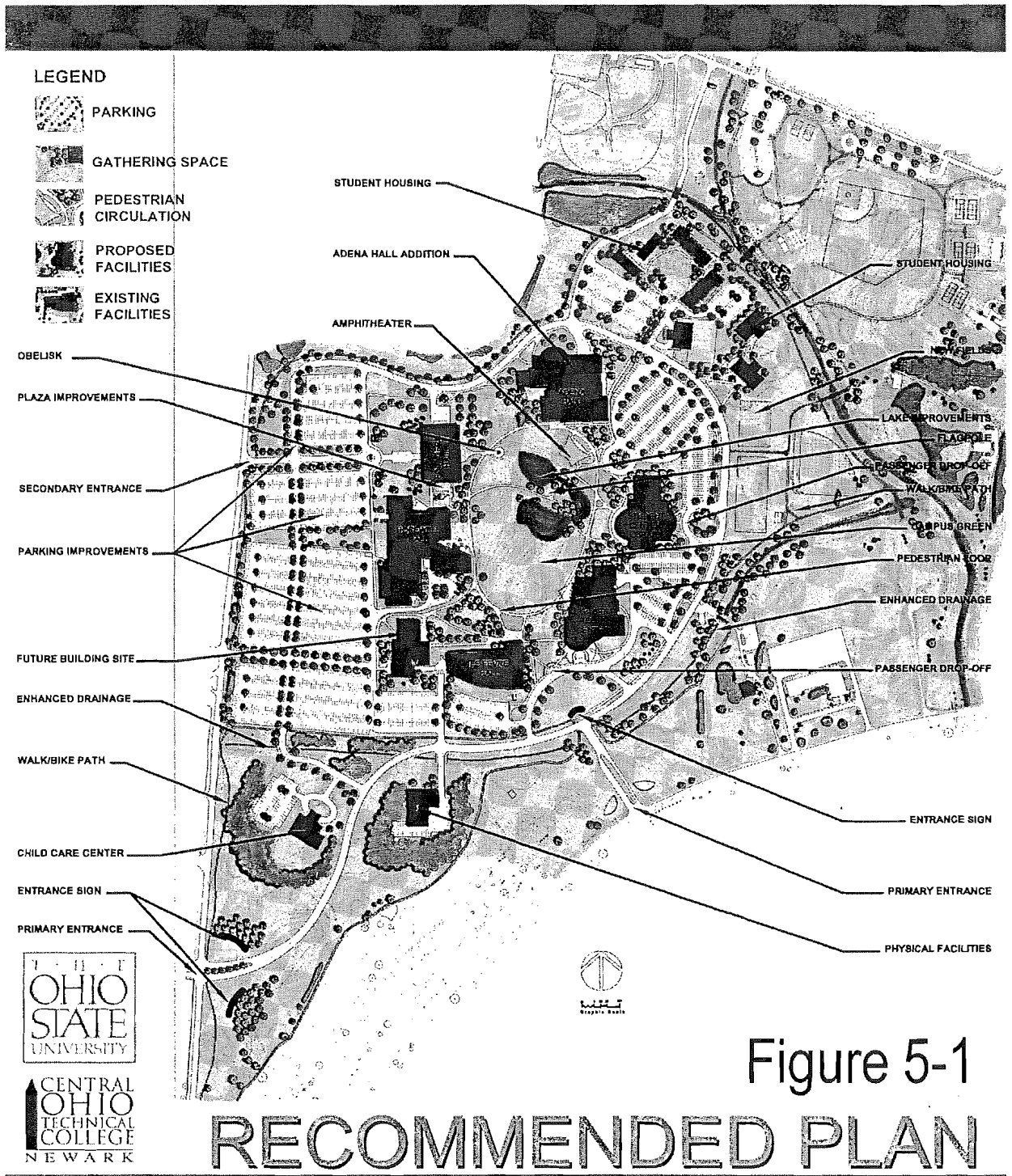

THE OHIO STATE UNIVERSITY AT NEWARK
 CENTRAL OHIO TECHNICAL COLLEGE
 NEWARK, OH

(APPENDIX XLV)

IMPACT OF MID-YEAR BUDGET REDUCTIONS

Scope of the Problem:

2.5% Rescission to annual appropriations for FY 2003:

State Share of Instruction for Columbus Campus	\$ 7.7M
Regional Campuses and ATI	0.5M
All other line items	<u>3.0M</u>
Total	<u>\$11.2M</u>

Proposed Solutions:

Reductions in State Share of Instruction will be absorbed as follows:

Colleges (0.81% of PBA Budget)	5.1M
Support Units (0.96% of PBA Budget)	<u>2.6M</u>
Subtotal	7.7M
Regional Campuses & ATI	0.5M
Reductions in line items will be absorbed by the affected units	<u>\$3.0M</u>
Grand Total	<u>\$11.2M</u>

Implications and Additional Considerations:

- Student Financial Aid distributions will be protected.
- These are one-time funds only. Permanent reductions will need to be addressed as part of the FY 2004 budget process.
- This plan addresses only current reductions announced by Governor Taft. If further reductions in state support are implemented, additional corrective action will be necessary.
- \$11.2 million is the equivalent in full time positions across all campuses of:
 - 108 Assistant Professors, or
 - 182 Academic Advisors, or
 - 263 Custodians
- Board will be asked to approve revenue and expenditure changes as part of the Third Quarter Report at their May 4th meeting.
- An estimated \$2.4 million in State Share of Instruction will be distributed to colleges and support units in May as a result of enrollment increases above initially budgeted amounts.

Net Effect of FY 03 2.5% Cut in State Share of Instruction

Fiscal College	Net Effect of \$7.7M Cut	Net Effect After Distribution of 2.4 Million SSI	Percent of Feb. 03 PBA
02-College Of The Arts	(248,383)	(224,457)	-1.11%
03-Biological Sciences	(305,936)	(269,190)	-1.48%
05-College Of Humanities	(359,797)	(359,797)	-0.84%
06-Mathematicl & Physicl Sci	(545,007)	(110,167)	-0.21%
07-Social & Behavioral Scien	(502,903)	(403,124)	-0.99%
10-College Of Business	(181,990)	19,829	0.08%
11-Food,Agricultrl & Env Sci	(282,574)	(269,391)	-1.71%
12-College Of Education	(386,269)	(386,269)	-1.45%
14-College Of Engineering	(737,517)	(291,495)	-0.57%
15-College Of Human Ecology	(85,370)	(85,370)	-1.48%
17-College Of Nursing	(75,140)	(33,230)	-0.65%
18-College Of Pharmacy	(93,136)	138,847	1.64%
19-College Of Social Work	(59,005)	(59,005)	-1.58%
21-College Of Dentistry	(210,008)	(155,413)	-0.94%
23-College Of Law	(64,743)	13,227	0.12%
25-College/Med & Public Hlth	(640,401)	(573,857)	-1.30%
27-College Of Optometry	(45,486)	(35,494)	-0.97%
29-College Of Veterinary Med	(284,699)	(223,554)	-1.29%
Total for Colleges	(5,108,363)	(3,307,913)	-0.81%

Net Effect of FY 03 2.5% Cut in State Share of Instruction

Support Unit	Net Effect of \$7.7M Cut	Net Effect After Distribution of 2.4 Million SSI	Percent of Feb. 03 PBA
30-Graduate School*	(25,406)	(21,035)	-0.32%
32-University Libraries	(287,032)	(237,645)	-1.03%
34-University Relations	(52,796)	(43,712)	-1.03%
35-Board of Trustees	(6,322)	(5,234)	-1.03%
36-Office of the President	(30,367)	(25,142)	-1.03%
37-Legal Affairs	(16,121)	(13,347)	-1.03%
40-Office of Research	(178,401)	(147,706)	-1.03%
41- Agricultural Admin	(16,910)	(14,000)	-1.03%
42-OAA**	(522,753)	(432,809)	-1.03%
44-Undergraduate Studies	(346,365)	(286,770)	-1.03%
45-Office of Student Affrs	(187,662)	(155,373)	-1.03%
46-V.P. for Health Sciences	(80,081)	(66,302)	-1.03%
50-Business and Finance	(808,246)	(669,180)	-1.03%
College Investment	Exempted	118,451	5.82%
Total for Support Units	(2,558,463)	(1,999,805)	-0.97%

* Exempts Grad Student Stipends from cuts

** OAA operating PBA only- exempts College Investment Fund (5% of SSI)

FY 03 2.5% Line Item Cuts

Unit	Line Item	Cut
Medicine	AHEC Program Support	5,894
	Family Practice	5,765
	Geriatric Medicine	3,723
	Primary Care Residencies	3,139
	OSU CLINICAL TEACHING	375,913
	Subtotal	394,433
Dentistry and Vet Med	OSU CLINIC SUPPORT	48,437
FAES	COOPERATIVE EXTENSION SERVICE	651,151
	AG RESEARCH & DEVELOP. CTR.	910,176
	Subtotal	1,561,327
OSURF	BioMEMS	5,758
	SEA GRANTS	7,049
	Subtotal	12,806
Libraries	LIBRARY DEPOSITORIES	9,594
Engineering	Computer Science Graduate Education	19,871
	OARNET	84,153
Super Computer/OARnet	Ohio Super Computer Center	113,589
	Subtotal	197,742
	MAPS	Math/Sci-Early Math. Placement Testing Prog
Education	Oh Res Ctr Math, Sci & Reading-Best Practic	23,030
	Math/Science Teach. Imp.-OSI-Discovery	5,000
	Reading Recovery*	4,125
	Subtotal	32,155
	SBS	Urban Univ Prog-Linkage Program
Humanities	Coll. Read. Init.-Early English Comp. Assess.	736
	Coll. Read. Init.-Collab. Artic. & Access. Proj.	1,625
	Coll. Read.-EECAP-Summer Writing Institute	625
	Subtotal	2,986
	OAA	OSU GLENN INSTITUTE
OLN	Ohio Learning Network	92,120
Core Funding	Success Challenge	237,729
	Research Challenge**	334,066
	Subtotal	571,795
Total Main Campus		2,960,079

Regional SSI and Line Items Including ATI

Line Item	Difference
SSI	537,191
Access Challenge	71,175
Jobs Challenge***	-
Total	608,366

* Appropriation from the Department of Education not reflected in OBR line items
 ** Research Challenge line item reduction exceeded 2.5% to protect Eminent Scholars allocations. Line was further reduced to account for carryover from 02.
 ***Jobs Challenge Executive cut was taken entirely by the Adult Workforce Center. There are no cuts to the Regional Jobs Challenge line.

THE OHIO STATE UNIVERSITY
OFFICIAL PROCEEDINGS OF THE
ONE THOUSAND THREE HUNDRED AND NINETY-THIRD MEETING
OF THE BOARD OF TRUSTEES

Columbus, Ohio, May 2, 2003

The Board of Trustees met at its regular monthly meeting on Friday, May 2, 2003, at The Ohio State University Longaberger Alumni House, Columbus, Ohio, pursuant to adjournment.

**

**

**

Minutes of the last meeting were approved.

**

**

**

May 2, 2003 meeting, Board of Trustees

The Chairman, Mr. Patterson, called the meeting of the Board of Trustees to order on May 2, 2003, at 10:40 a.m. He requested the Secretary to call the roll.

Present: James F. Patterson, Chairman, Zuheir Sofia, Tami Longaberger, Daniel M. Slane, Robert M. Duncan, Karen L. Hendricks, Dimon R. McFerson, Jo Ann Davidson, Douglas G. Borrer, Joseph A. Shultz, and Paula A. Habib.

--0--

Mr. Patterson:

I'm plagiarizing from Joe Shultz, but I'm a little disappointed. Last year at David Brennan's last meeting the Trustees all walked in with cowboy hats, so I thought today that you would all come in with flat tops!

--0--

**ELECTION OF OFFICERS
BOARD OF TRUSTEES**

Resolution No. 2003-110

WHEREAS pursuant to paragraph (B) of rule 3335-1-02 of the Administrative Code, the officers of the Board are to be elected at the May meeting to take office immediately following adjournment of the meeting (May 2, 2003) and shall hold their office through the May 2004 meeting:

NOW THEREFORE

BE IT RESOLVED, That the following slate of officers for 2003-2004 be elected:

Zuheir Sofia, Chair

Tami Longaberger, Vice Chair

David O. Frantz, Secretary

James L. Nichols, Treasurer

Upon motion of Mr. Slane, seconded by Mr. Borrer, the Board of Trustees adopted the foregoing resolution by unanimous roll call vote, cast by Messrs. Patterson, Sofia, Slane, McFerson, Borrer, and Judge Duncan, Mses. Longaberger, Hendricks, and Davidson.

--0--

COMMITTEE APPOINTMENTS 2003-2004

Resolution No. 2003-111

BE IT RESOLVED, That the appointments to Committees and representatives to various Boards for 2003-2004 be approved as follows:

COMMITTEE APPOINTMENTS 2003-2004 (contd)

Academic and Student Affairs Committee:*

Tami Longaberger, Chair
Daniel M. Slane, Vice Chair
Douglas G. Borrer
New Trustee
Paula A. Habib

Fiscal Affairs Committee:*

Robert M. Duncan, Chair
Jo Ann Davidson, Vice Chair
Dimon R. McFerson
Karen L. Hendricks
New Student Trustee

Facility Planning (AdHoc)*

(Subcommittee of Fiscal Affairs)
Robert M. Duncan, Chair
Daniel M. Slane
Karen L. Hendricks
Douglas G. Borrer

Audit Committee:*

Dimon R. McFerson, Chair
Tami Longaberger, Vice Chair
Jo Ann Davidson
Karen L. Hendricks

Agricultural Affairs Committee:*

Daniel M. Slane, Chair
Fred L. Dailey, Vice Chair, Ex Officio
Robert M. Duncan
Karen L. Hendricks
New Trustee
New Student Trustee

Governance Committee:

Zuheir Sofia, Chair
Tami Longaberger, Vice Chair
Daniel M. Slane

Government Relations Advisory Council:*

Jo Ann Davidson, Chair
Douglas G. Borrer, Vice Chair
Daniel M. Slane
Dimon R. McFerson
Paula A. Habib
New Trustee
David L. Brennan
Michael F. Colley
William Blair
Stan Aronoff

**The Arthur G. James Cancer Hospital
& Richard J. Solove Research Inst. Bd:**

Robert M. Duncan (3 years), Chair
Jo Ann Davidson (3 years)

University Hospitals Board:

Robert M. Duncan (3 years)
Jo Ann Davidson (3 years)

Campus Partners Board:

Douglas G. Borrer (3 years)

Research Foundation Board of Directors:

Karen L. Hendricks (2 years)

University Foundation Board Ex Officio:

Class of Directors:

Tami Longaberger (1 year)
Dimon R. McFerson (2 years)
Douglas G. Borrer (3 years)

Wexner Center Foundation Board:

Leslie H. Wexner (2005)
Jo Ann Davidson+

Ohio State University Affiliates, Inc.:

Affiliated Entities Committee:

Zuheir Sofia (1 year)
Tami Longaberger (2 years)
Daniel M. Slane (3 years)

Regional Campus Trustee Liaisons:

Jo Ann Davidson, Mansfield
Tami Longaberger, Newark
Robert M. Duncan, Marion
New Trustee, Lima

Self-Insurance Trust Board:

Dimon R. McFerson (3 years)

Richard M. Ross Heart Hospital:

Dimon R. McFerson

+President's Appointment

***Board Chair, Ex Officio member of all committees**

Upon motion of Mr. Sofia, seconded by Mr. McFerson, the Board of Trustees adopted the foregoing resolution by unanimous voice vote.

--0--

CHAIRMAN'S REPORT

Mr. Patterson:

A few years ago, I had the opportunity for the first time to hear David Citino speak at a commencement. At that commencement he gave one of the most wonderful poems I have ever heard. I immediately became a fan of David Citino's and I have had the opportunity in the last few years to hear him, to read his poems, and to see his work.

This past October, the Board took action naming David Citino as the poet laureate of The Ohio State University. When the Board took this action, it did so as a way of honoring this wise and inspiring poetic voice of the University. However, what we had not quite anticipated was just how much work we were going to make for this maker of words. And, today, David, it gives me great pleasure to announce that we're going to add an annual stipend to accompany the title that the University is so proud to have you bear.

At each Trustees place is a book, *The News and Other Poems*, by David Citino. I hope if you haven't had the opportunity to read some of these wonderful poems -- the way that David has such a talent for putting the words together to make so much sense and to read so well and sound so fine -- you will be able to do so now.

Over the years the Board has been served so well by its Student Trustees. I can remember all of the Student Trustees that I've had an opportunity to serve with and they all have been outstanding.

That's also true in the case of Joe Shultz, who along with myself, is attending his final Board meeting today. I speak for all of those who have served with Joe when I say that his exuberant, reasoned, and thoughtful approach has been of great benefit to our deliberations as a Board and to the University.

Joe is graduating next month from the College of Food, Agricultural, and Environmental Sciences. Not everyone is aware of Joe's farming background. His family has a sheep farm in DeGraff, Ohio. After his sophomore year, Joe took a year off from Ohio State to serve as state FFA president, and then national vice president of FFA. For those of you who don't know, to be a national vice president of FFA, these are some of the most outstanding students in the country.

When he came back to campus to continue his studies, he became a Student Trustee. If you recall, *the Lantern* ran a wonderful article about Joe. But the headline captured it all: "From Managing Flocks to Trustees." He was hoping that we would forget that headline! Following graduation and the summer off, Joe is going to begin his graduate studies at Cornell University in the fall.

Joe, you have been just an excellent Student Trustee and a wonderful example of the committed students that we have here at Ohio State. We thank you for your many contributions and we wish you every success in the future. In recognition of your outstanding service to this University, we would like to present you with this plaque.

Mr. Shultz:

Thank you. Mr. Patterson, if I could just take a moment to share a little about my experiences and reflect on what being a Trustee does to an undergraduate student.

CHAIRMAN'S REPORT (contd)

Mr. Shultz: (contd)

I've traded in my weekly reading of *Sports Illustrated* now for the *Chronicle of Higher Education*. Simple questions from my friends about, "How are things at Ohio State?" end up being long conversations about the finer points of the Academic Plan. Sometimes I have late night conversations with student government people about the long-term impact of rebudgeting on the University. As you can see, it's quite a different atmosphere that I live in now compared to two years ago.

I also look at the University differently, as I see professors who teach my classes. I used to look at them as people who probably sat around in offices thinking about how they could make students' lives worse. Now I see underpaid professionals who do amazing research, great teaching, and service to the State of Ohio.

However, the most significant change I've seen in the past two years has been the people who I've had the chance to interact with. It's amazing for a 23-year-old student to have the chance to work with President Kirwan, then to see Interim President Jennings take the helm for a couple months, and then, finally, to see the enthusiasm and the energy that President Holbrook has brought to the University. It's quite an experience for a young person.

The opportunity to work with administrators is absolutely an experience that gives me great pride in our University and the direction that we're headed. But most importantly, it has been the opportunity to work with the other Trustees and, for all of you who haven't had the chance to work firsthand with these people, it is the most amazing group of people who are dedicated, talented, and passionate about the mission of The Ohio State University. They are excellent guardians for one of Ohio's most valuable institutions.

Finally, I'd like to thank some of those people who have made my experience so very special. Three ladies who sometimes don't get the most recognition, but are very important to me are Maureen, Lucy, and Suzanne – they made sure I never missed a meeting or a bus – thank you. I want to thank Drs. Napier and Frantz, who have made sure that I've had the proper guidance as a young Student Trustee. And I'd like to thank someone who is special to all of us, and that is Chairman Patterson. For a young person in the industry of agriculture, I can think of no better role model than Chairman Patterson. It's been a privilege and an honor to serve as the Student Trustee while the Board of Trustees was under his leadership.

Thank you very much for this amazing experience and the opportunity to be involved in such a unique way at our great University.

Mr. Patterson:

We should note that one of the other nice things about having Joe as a member of the Board was the opportunity to meet his parents, Bill and Susan Shultz. Susan is with us today. Susan, would you stand and be recognized for your wonderful son. Thank you.

--0--

PRESIDENT'S REPORT

President Karen A. Holbrook:

As the academic year begins to draw to a close, we create special events to celebrate the many successes of our students, faculty, and staff. We celebrate great faculty, great students, and great programs on this campus. This is a combination that leads to a great future for individuals, as well as for our University.

We recently honored 19 faculty members at our annual faculty awards, a recognition ceremony for their exemplary teaching, service, and research. And three days ago, we learned that Dr. Linda Saif, professor in the Food Animal Health Research Program in the Department of Veterinary Preventive Medicine at OARDC, was elected to the National Academy of Sciences. As you know, this is one of the highest honors that is bestowed on any American or international scientist. Dr. Saif is a world authority on enteric viral infections. Last year, she was also named as a Distinguished University Professor.

I am also pleased to bring to your attention two important personnel actions that you will be asked to approve later during this meeting. Dr. Ray and I are recommending the appointment of Dr. Robert Bruggemeier as dean of the College of Pharmacy. Dr. Bruggemeier is an outstanding scholar and researcher who is a fellow of the American Association of Pharmaceutical Scientists and the American Association for the Advancement of Science. Bob is one of our own faculty members who surfaced as the very top candidate in a national search for the position. He is with us today and I would like to ask him to stand so we can introduce him to you.

We are also recommending the appointment of Dr. Richard Freeman as dean of the College of Mathematical and Physical Sciences. Dr. Freeman is presently the Edward Teller Professor and chair of the Department of Applied Science at the University of California at Davis. He, too, is an exceptional scientist who spent 20 years at AT&T Bell Labs and at Lawrence Livermore National Labs before joining UC-Davis. Dr. Freeman is an internationally known expert in laser physics and with his appointment, and with an eminent scholar position in the same field to be added in the future, Ohio State will be among the leaders in this field.

I want to focus the remainder of my remarks today on the success of our students, who in many ways represent the true success of any university's quality. Earlier this week, I had the great pleasure of attending a reception for some of our students who have won or been nominated for or who have become finalists in the Mellon, Truman, Rhodes, Udall, and Goldwater Scholarships competitions and as recipients of the National Science Foundation Fellowships and other national and international awards. These students will be attending some of the most prestigious graduate and professional schools in the nation, including Stanford, Harvard, Cornell, Cal Tech, the University of Chicago, and The Ohio State University. Their success reaffirms Ohio State's excellence. Great schools recruit from great schools.

Undergraduate students are also doing significant original research projects and let me provide two examples. Jodi Poorman, a cancer survivor and a senior pre-med student, is researching the effect of grape extracts on Ewing's Sarcoma cancer cells. With the help of her advisor, Assistant Professor Minnie Holmes-McNary, Jodi recently presented her research findings at the annual conference of the Society for Experimental Biology and won the third place prize for her research project.

PRESIDENT'S REPORT (contd)

President Holbrook: (contd)

Courtney Howard, a senior English major with a minor in political science, developed a program for the Ohio Association of Nonprofit Organizations to help them work with legislators. This past quarter, she worked for the Child Welfare League of America in Washington, D.C., where she researched methods of punishment for children involving restraint or seclusion. She did that research through an internship with the John Glenn Institute for Public Service and Public Policy.

Some of the most significant research that is being done by our undergraduate students at Ohio State over the past year will be on display at the Denman Undergraduate Research Forum, one of the premier undergraduate research forums in the nation. For any of you who want to see some outstanding examples of the kind of research that's carried on by our undergraduate students, I would hope you would be able to join us at the Blackwell Inn and Pfahl Hall Executive Board Room on May 14. You'll see some absolutely outstanding work.

Community service also contributes to the academic excellence of our students. Studies reported in a recent book, *Making the Most of College* by Harvard Professor Richard Light, reveal that students who are the happiest and most satisfied with their college experiences are those who are involved in out-of-the-classroom experiences. When the author asked students to describe a "critical incident or moment that had changed them profoundly," 80 percent of them chose some kind of activity that was outside of their classroom experience.

Their response underscores why we are expanding service-learning opportunities, where service to the community is an integral part of the classes' academic activities. Well over 1,000 Ohio State students are currently enrolled in more than 50 service-learning courses on the Columbus and regional campuses, where students are, for example, tutoring in reading and writing in elementary and middle schools and working on the front lines with social service organizations. One group has been developing solutions to clean up and beautify the Olentangy River. Through a class on city and regional planning, our students studied and developed recommendations regarding housing code violations in the University District.

Service-learning is a key teaching and learning strategy. Among many ways students and faculty can make significant contributions not only locally, but in communities all across the nation.

For example, over Spring Break junior integrated social studies major Josh Harraman volunteered at the New York City soup kitchens and homeless shelters. He's one of several students who participated in Ohio State's Alternative Spring Break trip. Josh described his trip as eye-opening and one that has taught him never to take anything in life for granted.

Many of our undergraduate student leaders also participated in other student service activities. A new one that they've organized is a community building event in the University District called "Invest Yourself." The flyers say, "It's your university, it's your community – invest yourself in it." On Sunday, May 18, 100 students will team up with 100 faculty members and administrators to walk through campus neighborhoods, knocking on doors of students' residences, talking with them about the importance of commitment to the University and their community, and asking them about their ideas as to what the University might do to help build the bonds of the community within the University and our off-campus neighborhoods.

PRESIDENT'S REPORT (contd)

President Holbrook: (contd)

We're proud of the many ways our students are engaged in the University community and beyond. The caring of our students for the families of the students who died tragically in the 17th Avenue fire and for the students who survived was remarkable. Several students participated in the memorial service and many more attended.

After the service I had the opportunity to meet with a number of the men from the Sigma Phi Epsilon fraternity who, on the night of the fire, knocked on doors of all of the neighbors to wake them up and then opened their own house to those who were displaced and to the Red Cross so they could immediately help anyone affected by the fire. Their service to their neighbors, fellow students, and community is truly something to celebrate.

Let me close by expressing the University's thanks and esteem for four students in particular, who have made exceptional contributions to the Ohio State community through their roles as student leaders.

Through two terms as the Undergraduate Student Government president, Eddie Pauline has worked to improve the out-of-class connections between students and faculty. He served as an active and vocal advocate for the interests and priorities of our undergraduate students.

Similarly, Briggs Cormier, as a two-term president of the Council of Graduate Students, has worked many hours on G-CUE, a joint project of the Council of Graduate Students and the Graduate School, designed to improve the graduate student experience at Ohio State. Briggs has served as a thoughtful, effective advocate on graduate student issues.

I also want to recognize Todd Armen, who has served two terms as president of the InterProfessional Council. Despite a very demanding schedule as a medical student, Todd has led IPC to take a more active role in campus-wide government, helping to keep the concerns of professional students in mind of all when decisions are being made.

Again, I want to recognize and thank Joe Shultz for his hard work, integrity, and insight that he brought in his service of two years as the undergraduate student member of the Board of Trustees.

I'd love to have the student leaders stand so we can thank and recognize them. Thank you very much. We're glad to have Eddie, Briggs, and Todd with us this morning. All of these student leaders are terrific examples of student success in the classroom and in the larger community, and they have very promising futures ahead of them.

Across this University, students truly are doing something great through their scholarship and service. Thank you for allowing me to share some of their successes with you this morning.

--0--

STUDENT RECOGNITION AWARD

Ms. Habib:

The Student Recognition Award is presented each month by the Board of Trustees to a student in honor of his or her achievement in area of study, service to the University and/or community, and/or research achievements that have been a credit to the college and the University. This month's recipient is Keisha M. Wells, who was nominated by Dean Alutto from the Fisher College of Business.

If Keisha and Professor Deb Ballam could please come forward; I would also like to recognize her family who is with her today, her parents, Charles and Kim Wells, and her grandparents, Harley and Mattie Anderson. Thank you all for coming to celebrate this for Keisha.

Keisha graduates this spring with a marketing major, an economics minor, and a job at Procter & Gamble. She has spent the past three summers as a brand management intern at Procter & Gamble, where last year she led two product design development initiatives and presented a recommendation for market entry of both products to senior management.

Keisha's academic achievements are extraordinary and have received well-deserved recognition. She was among the top 200 OSU students honored at the 2003 President's Salute to Undergraduate Academic Achievement. She has never missed being on the dean's list, in spite of a course load of 20 credit hours or more every quarter but one, and has been a member of Fisher College's Honors Cohort and the Mortarboard National Honor Society. Fisher College Pacesetter Award winners are selected annually to recognize the best of the best. Keisha has been honored twice; first with the Fisher College Pacesetter Award in 2002, then with the 2003 Most Outstanding Female Award.

Keisha has managed to make significant contributions to the college and University community as well. She is president of the Council of Black Students in Administration, a member of the American Marketing Association, the NAACP secretary in 1999, and served as the representative to the Office of Minority Affairs Advisory Board meeting in Spring 2002. She accompanied then-President Kirwan and the Office of Minority Affairs on a recruiting trip to Cincinnati area high schools in 2000, participated in the Conversation Partner Program in 2002, and volunteered as a peer mentor in the Office of Minority Affairs. In her spare time, she has tutored Indianola Middle School students on a weekly basis since 1999.

While Keisha's accomplishments are impressive on paper, her resume only provides a glimmer of the real Keisha Wells. What is most impressive about her is the quality of her character. Keisha is just a wonderful human being. Her own words from her application to the Fisher College Honors Cohort Program best illustrate the kind of person she is:

"Open-mindedness, focus, and passion are the three seeds which were sown into my life at a very young age. In fact, they have become the foundation on which I stand, and which will continue to lead my life toward success."

About open-mindedness Keisha wrote:

"I have learned that once the seeds of open-mindedness are planted, they must be constantly nurtured for them to grow into plants of their full size and potential. Such nurturing involves

STUDENT RECOGNITION AWARD (contd)

Ms. Habib: (contd)

taking risks and stepping outside one's normal boundaries to reach an understanding of others. While secretary of the NAACP at Ohio State University, my commitment to open-mindedness was tested and strengthened nearly every day. As I lent an ear to anyone, not simply African-Americans, who felt as if they had been treated unjustly for any reason, I was forced to fight any bias that I might have possessed for the sake of listening and understanding. The NAACP offered many opportunities when I had to remember that everyone is standing in a different position and will behave differently based on their experiences.

As for focus, while learning and growing from the experiences of others, I have learned that I must still focus intently on my personal goals. The steps that I need to take to achieve my goals must be as planned and precise as my steps on a dance floor. This focus has resulted in victory over anyone who has ever said that I would receive something far less than what I have desired. For example, when everyone told me that I would never get a full academic scholarship, and I would never be able to maintain a high level of academics in college, I laughed while pitying their ignorance. When they told me it would be too hard for me to get an internship at Procter & Gamble, I responded by working consecutive summers as an intern in the Procter & Gamble headquarters. It was this experience that has allowed me to narrow my focus from simply being successful to becoming a respected and effective woman in the corporate world.

And finally, passion: I would not have been able to remain focused without my passion for winning, learning, and sharing. I owe this to the sense of humility that my parents have instilled in me. I know that I'm only here because of all the people who fought, cried, and died for me. When I think about all that my grandparents and their grandparents went through for my sake, I do not feel as if I have any choice but to strive to give all that I can and receive everything that is intended for me. It is their stories that create the passion that pushes me to compete for the best life has to offer. It is this passion that wakes me up every morning and the same passion that I've carried with me as a tutor at Indianola Middle School. I felt as if it were my responsibility to fight for the success of these children, as so many people have fought for me."

Keisha Wells, someone who already has done great things and whose destiny is to continue doing something great. We have no doubt that she will make Ohio State as proud of her as an alumna, as we have been of her as a student.

Being a student myself, it is a great honor for me to be able to present a student like Keisha to the Board of Trustees. The Board appreciates the chance to meet students, especially ones who exemplify exactly how bright and committed the students at Ohio State really are. Congratulations, Keisha.

STUDENT RECOGNITION AWARD (contd)

Mr. Patterson:

There would be a number of things that one could say, but it's hard to think of anything other than "Wow!" As I sat here looking out at the audience I saw one proud family, but most of all I saw a very proud mother. Mrs. Wells, I was taken by your expression as you looked at Paula as she was talking about Keisha. Congratulations to all of you. Very, very nice.

--0--

SELECTIVE INVESTMENTS PRESENTATION

Provost Edward J. Ray:

Ohio State's Selective Investment Awards program reflects this institution's commitment to academic excellence. Beginning in 1997 the initiative has identified some of our strongest departments and programs, and provided them with the resources needed to move to the next level of excellence in their fields.

The program includes a shared financial commitment. One million dollars in continuing funding is dedicated to implementing the plan of each of the 13 recipient programs, with half provided from central funds and half provided from internally reallocated funds by the sponsoring colleges.

The departments selected to receive Selective Investment Awards were chosen based on their importance to our academic mission, their existing high level of excellence, their centrality to the mission of the University, their ability to promote inter-program collaborations and interdisciplinary activities, their ability to enhance excellence in related programs throughout the University, and their contribution to the University's outreach goals with business, industry, and the community. Results of our investments are already being realized.

Today we will hear from the chairpersons of Electrical Engineering and Mathematics, who will discuss the impact and uses of their Selective Investment funds. I'd like to ask Professors Zheng and March to come forward and provide us with those presentations.

Professor Yuan F. Zheng: [PowerPoint Presentation]

Good morning, members of the Board of Trustees and President Holbrook. My name is Yuan F. Zheng, professor and chairperson of the Department of Electrical Engineering. Today it's my honor to present to you the positive impact that the Selective Investment Award has brought to the Department of Electrical Engineering.

First I'd like to review our investment strategy. More than five years ago when we developed the proposal, our vision was to focus on information in the wireless communication technologies where it would benefit the Ohio economy the most. Traditionally Ohio industries have focused on manufacturing, but not on expanding high tech and information technology. We feel that if we can distinguish the Department of Electrical Engineering at the flagship university of the state, we will be able to help attract new information technology-related industries to the state.

The second strategy is to build on the existing strengths of our department. We have five thrust areas we consider traditionally to be very strong, with the first four areas being enabling technologies for information technologies: 1) the

SELECTIVE INVESTMENTS PRESENTATION (contd)

Professor Zheng: (contd)

ElectroScience Laboratory, which has strength in wireless communications and microwave technology; 2) high performance computing -- today computing is related to everything, but information technology is needed; 3) information processing systems related to communications and signal processing; 4) electronic materials, which are for high-speed devices that can handle a large volume of information; and 5) intelligent transportation, an application area for information technology which is also related to the Ohio economy, because in Ohio a lot of companies are in the transportation business.

Our strategic goal is to rank among the top ten electrical engineering departments in the country. At the time of our proposal, we studied very carefully those top-ranked departments in the country and observed that the perceived quality of a department is closely related to the size of the faculty.

This slide will show the National Research Council ranking of the Ph.D. programs in 1993 and, by the way, the new ranking will be coming out this Autumn Quarter. We can see that most Big Ten universities ranked very well with their departments of electrical engineering and that they traditionally have very strong engineering programs -- Illinois ranked #3, Michigan ranked #6, Purdue ranked #8, Wisconsin ranked #16, Minnesota ranked #18, and Ohio State ranked #22. This ranking relates to all universities, including MIT, Stanford, and Berkeley.

In the right-hand column you can see the faculty size and it so happened that the best-ranked universities also had the largest faculty size in 1993. We had only 41 faculty -- we were the smallest -- and were the lowest ranked among these universities. So based on this, we felt that our strategy should be to increase the faculty size in the five areas of strength which I mentioned earlier. We wanted to hire as many faculty members as possible in those five areas, using the Selective Investment Award and, of course, we wanted to hire the very best faculty in the field. Our strategy was also to increase the size of the faculty, since the size of the faculty is so important to the reputation and overall strength of a department. We also wanted to stretch the award to get the most benefit and, therefore, we put emphasis on junior faculty.

These two pictures show some of our students. If you remember a few years ago, we had commencement on the Oval. It happened to be one of the hottest summers, so some of our students just took off their gowns. The picture on the right shows our students in the laboratory.

I'd like to very quickly review the faculty we have hired. In 2000 we hired Associate Professor Paul Berger away from another university. His area is electronic and nano-devices and he is with me today. Professor Berger, a very distinguished professor, received his Ph.D. degree from Michigan in 1990. He joined us less than three years ago and has already won a major National Science Foundation award of more than \$1 million. He was leading a team of major universities and Ohio State against the leader. Also, he has put forth a lot of effort in undergraduate research involvement.

In 1999 we hired Assistant Professor Ben Coifman, from UC-Berkeley in the area of intelligent transportation. Since he joined us, he has won the National Science Foundation Career Award. This award is the most prestigious award given to a junior faculty member, and is very competitive and difficult to win. In Autumn 2002 Assistant Professor Eylem Ekici, from Georgia Tech, was hired in the area of computer networks. I should mention that Michigan, Berkeley, and Georgia Tech are all ranked in the top ten in electrical engineering.

SELECTIVE INVESTMENTS PRESENTATION (contd)

Professor Zheng: (contd)

Also in 2000 we hired Assistant Professor Heshman El Gamal, in the wireless communications area. Professor Gamal graduated from the University of Maryland, also a top-ranked university in electrical engineering, and in less than three years he has won two National Science Foundation grants. And Associate Professor Jin-Fa Lee, a well-established expert in microwave technology. Professor Lee received his Ph.D. degree from Carnegie Mellon University in 1989.

We hired three more junior faculty: 1) Assistant Professor Wu Lu, in the area of electronic devices, received his Ph.D. degree from Southeast University in China and received post-doctoral training at the University of Illinois. He has won a major National Science Foundation equipment grant, which is more than \$1 million; 2) Assistant Professor Andrea Serrani, received a Ph.D. degree from Washington University, is an expert in non-linear control -- an area that can be applied to intelligent transportation; and 3) Assistant Professor Philip Schniter hired in the area of signal processing and communication. In January he told me that he won the National Science Foundation Career Award, again, the most prestigious award given to junior faculty.

Using the Selective Investment Award, we have hired eight junior faculty -- associate and assistant professors -- significantly increasing the size of our department. What is the positive impact these hires have brought to us? Looking at the most recent data, enrollment has grown to an all-time high. We have more than 1,000 undergraduate students and more than 300 graduate students. Last quarter President Holbrook attended a College of Engineering faculty meeting and she mentioned that we should increase the ratio of graduate students. I think we are already there; we have more than 25 percent graduate students. For a research university, a high percentage of graduate students is very important.

According to the most recent survey of the Electrical and Computer Engineering Department Heads Association this academic year, our department is ranked well in many categories. We now have 50 faculty, instead of the 41 in the previous ranking. Our rank in the country, again, including every top university, is #14 in size. In the number of Ph.D. graduates, we're ranked #15; for the number of M.S. graduates, we're ranked #16; and for the number of bachelor degree graduates, we're ranked #13.

Unfortunately, our faculty salaries are not ranked very high. Salaries for professors ranked #22, associate professors ranked #23, and assistant professors ranked #22 in the country.

Research expenditures have increased since the 1996-97 academic year, with the most significant increase being since we received the Selective Investment Award. Last year our research expenditures, which is ranked #15, compared with all of the departments on campus, was the highest at \$14.113 million. In 1996-97 our research expenditure was about \$8 million. So in five years, we have increased more than 80 percent. I told our faculty our goal is to have \$20 million in 3-5 years.

Graduate student quality is improving because we have more and better quality faculty, and the quality of our environment as a whole for both faculty and students has also improved. If you look at the GRE of new graduate students since 1999, you'll see it's steadily growing even though we have more graduate students. Now our standard is even higher.

SELECTIVE INVESTMENTS PRESENTATION (contd)

Professor Zheng: (contd)

This slide shows a picture of an autonomous golf cart – the cart can travel by itself anywhere. It looks as though the student riding on the cart has lost his way, perhaps since the cart has been driving. At the bottom is the web header of our research laboratory called, “Signal Analysis and Machine Perception Laboratory” and the picture on the right is the Dreese Labs building.

New faculty have brought perspective not only on research, but also teaching to the department. This has benefited not only the graduate students, but also the undergraduate students. Professor Berger has mentored more than 11 undergraduate researchers since his relocation to Ohio State in 2000, with seven students in summer 2002 alone. This picture shows his research group of mostly undergraduate students taken last summer.

Because the overall mentality of our faculty to improve research and teaching is helpful to our students, two years ago we started a program with a professor to be an advisor especially for women and minority students. Those efforts resulted in our department receiving the Minority in Engineering Department of the Year Award in April. And because of the growing enrollment, in 2001 we added one more undergraduate advisor so that the undergraduate students have the best advising available possible. We consider our advising team to be the best or at least one of the best on campus.

I have a lot of things to say about the positive impact that the Selective Investment Award has brought to our department, but I only have 10 minutes. So I'd like to summarize what I've presented: 1) the Selective Investment Award has enabled the department to hire eight new faculty members; 2) by hiring high-quality faculty, we have not only increased the faculty size but also improved the overall quality of the faculty and students; 3) the Selective Investment Award has been the only major program, since I joined Ohio State, for a selected unit to increase the strength significantly. The other program, Academic Enrichment Program, is interdisciplinary, between the units, but Selective Investment serves individual units; and 4) I would recommend that new investment should continue to the selected units or to other units to keep the momentum going under the current budget situation.

Thank you very much for your attention and I will be glad to entertain any questions you may have.

Mr. Patterson:

Are there any questions or comments? It's very impressive what you folks are doing and the strides that you make, and I think it's a testament, Ed, to the Selective Investments Program. Do you have a comment?

Provost Ray:

No, Mr. Chairman. I think if there are no other questions or comments, we could ask Professor March to provide the presentation for the Department of Mathematics.

Professor Peter D. March: [PowerPoint Presentation]

Thank you very much for providing me an opportunity to come before the Board and explain a little bit about what's happening in the Mathematics Department and how Selective Investment has enabled us to move the department forward.

SELECTIVE INVESTMENTS PRESENTATION (contd)

Professor March: (contd)

I'd like to begin by giving you a snapshot of the department, perhaps to give you a sense of the range of activities that are going on in mathematics, to tell you briefly about the essence of our Selective Investment proposal that was funded in the year 2000, and then tell you something about the impact of Selective Investment on the mathematics department.

We're a large department and large in faculty. We have quite a few post-docs, which is a typical and very interesting thing in mathematics. At any given time we have 24 post-docs, who are on rotating three-year appointments, and 100 graduate students -- and heading towards 125-130 this year, so that's going up. We have 350 plus declared math majors and graduate 60-75 of them per year. And we're helped by really an excellent staff of 22 dedicated people.

One of the things the mathematics department does is teach at the broadest possible level, from pre-calculus and remedial mathematics all the way up to research seminars and cutting-edge research courses. We teach about 30,000 students per year. Some of these are the same students, counted more than once, but roughly speaking, every student who comes to Ohio State takes a math course. We teach about six percent of the University's total credit hours of instructions. We have a very wide range and touch a lot people's lives.

I want to mention the impact of selected admissions, which we can really feel in the mathematics department. We have dramatically decreased enrollments in remedial mathematics courses and a nearly corresponding increase in the enrollment in our various calculus sequences. So this is a very good development.

Since we interact with virtually every student on campus at the undergraduate level, we've tried to develop various student support services to help them get through their mathematics classes and on to the math major if they're majors. The truth is most students go on to other majors and we'd like to try to enable them to get their mathematics courses done in a timely fashion so they can make progress on their degree program.

One of the projects that we've instituted in the last several years was the Mathematics and Statistics Learning Center. This center is staffed by 3 1/2 full-time staff and provides a wide range of tutoring services for all the major undergraduate service courses, from remedial mathematics up through the calculus and differential equations courses. They also provide a wide range of seminars and study skills programs to help students learn their mathematics.

Another support service we provide is the Mathematics Counseling Office. This office is staffed by three wonderful and dedicated staff members. They help with every aspect of a student's interaction with the mathematics department and the mathematics courses. As I mentioned, we have approximately 350 majors, but by far the majority of the work done in the counseling office is for non-majors, people taking mathematics in support of their intended majors in the sciences, in engineering, and in social sciences.

Finally, we have a wonderful GA support service. Two staff members are dedicated to help train our GTAs to be good teachers in the classroom. Every incoming mathematics graduate student takes a 10-week course on teaching at Ohio State University in the summer before their first year. They're videotaped and the staff visit the students in their classroom and give them advice on how to improve their communications and teaching skills.

SELECTIVE INVESTMENTS PRESENTATION (contd)

Professor March: (contd)

Let me focus for a moment on a couple of our undergraduate majors programs that we are quite proud of. One is the actuarial science program, which produces about 10-15 graduates per year. The best of them leave with three and four job offers in their hands. This is the sixth or seventh year where we had 100 percent employment among all our graduates in actuarial science.

We have a very active honors program with 8-12 graduates per year. Their career trajectories on to graduate school and they go to places like NYU, Princeton, Cornell, and Stanford. We're very proud of them.

I've been speaking a little bit about the teaching side of the department, but I'd like to speak now about the research side. One of the conventional divisions of research in mathematics is pure or fundamental mathematics. I don't necessarily like the pure versus applied dichotomy. I think it's really a distinction without a difference, but it's there. This is mathematics, which is generated by issues and goals inside the subject – number theory, topology, and algebraic geometry. These are old, old areas of mathematics, which are still extremely vital and important, and we have quite a bit of strength in these areas.

Then there is applied or interdisciplinary mathematics – differential equations and scientific computation – and we have a very strong new emphasis in mathematical biology. Mathematical education is a huge area and the area we've chosen to focus on is the mathematical preparation of schoolteachers. We think that for a research institution, this is the point of maximum leverage for us in the field of mathematics education.

So those rough divisions of the research agenda in the mathematics department are reflected in the Selective Investment proposal that we made. We aim to make five senior appointments: two in pure math, two in applied math, and one in mathematics education. We devoted a significant portion of the budget in the proposal to fund graduate research assistantships. Mathematics as a whole across the country is underfunded from federal sources and most of our graduate students get their stipends in the form of teaching assistantships. We intend to try to make our graduate program more attractive by offering more graduate research assistantships and we're trying to enhance the computing environment, which is so crucial for much of modern mathematics.

Avner Friedman was our first Selective Investment hire and we were very pleased to have him join the department last year. He was formerly a regent's professor at the University of Minnesota and is a member of the National Academy of Sciences and American Academy of Arts and Sciences. Professor Friedman came here in conjunction with our successful proposal to the National Science Foundation to develop a new national mathematics institute, called "the Mathematical Biosciences Institute." I'll speak just a bit more about that later.

Our second hire we made last year was Herb Clemens into the mathematics education position. I can't tell you how pleased I am to be able to say he came here and I get positive feedback about this everywhere I go around the country. Professor Clemens was a distinguished professor at the University of Utah and serves on the national Committee on Mathematics Instruction from the National Academy of Sciences. He is also the secretary/treasurer on the Committee on Development and Exchanges of the International Mathematical Union and director of the Institute for Advanced Study at Park City Mathematics Institute, Park City, Utah. They have a wonderful summer program there where top-flight researchers, graduate students, post-docs, high school teachers, undergraduate

SELECTIVE INVESTMENTS PRESENTATION (contd)

Professor March: (contd)

students all get together and interact around a single research theme, which changes from summer to summer.

We have ongoing searches in the three remaining senior areas: 1) number theory; 2) global analysis, an area which encompasses geometry and partial differential equations; and 3) mathematics and computation, which given the Mathematical Biosciences Institute we are trying to interpret this senior position as computational biology.

I'd like to tell you a little bit about the impact of Selective Investment. The mathematics department is changing very rapidly right now and it's due entirely to the opportunities we could exploit by having Selective Investment funding in our department.

Particularly we had the mathematics and biology position available, which we used to bring Avner Friedman here. The process of hiring Avner was intimately intertwined with making an ultimately successful proposal to the National Science Foundation to create the Mathematical Biosciences Institute (MBI). We're betting -- and actually a lot of places around the country are betting -- that the relationship between mathematics and biology in this century will be as stimulating and productive as the interaction between mathematics and physics was in previous centuries. With the MBI here at Ohio State, we're positioned to be a national leader in this area.

The MBI award was \$10 million over five years, with a serious third year review and an option to renew the contract with NSF at the end of five years. So we're hoping and expecting 10 years of funding at about \$2 million per year.

For me, working with Avner has been a vertical learning curve. We used some of the experience gained from this MBI proposal to submit an ultimately successful proposal for another large project from NSF in Vertical Integration in Graduate Research and Education or VIGRE. VIGRE supports research and education projects at undergraduate, graduate, and post-doc levels -- that is the verticality. Every quarter we have 2-3 working groups, which have faculty, post-docs, grads, and undergrads coming together to work on research projects. The VIGRE award is \$3.9 million over five years, under the same kinds of conditions -- a serious third-year review and an option to renew at five years. We expect and hope that we'll continue receiving that kind of funding at that level for the next decade.

One of the ways empirical measurements can show the impact of Selective Investment -- it's not the only one, but it's a fairly dramatic one -- is with the MBI proposal. When you rank universities by their total grant support from the Division of Mathematical Sciences at the NSF -- and this includes grants obtained by mathematics faculty, as well as statistics faculty who we worked with intimately on the Mathematical Biosciences Institute proposal -- Ohio State was ranked #1 last year, and in pretty good company. So we hope to continue that. I can't promise that we'll continue to be #1, but we hope to be in the top ten for a while.

The other impacts are very clearly human impacts. Bringing very distinguished senior people into the department, being able to fund research projects with undergraduate and graduate students, and having a close level of interaction among the people of all stages of career development in the math department has just been tremendous. There is a lot of lively activity now and we're very optimistic to continue to hire distinguished faculty into the remaining open

SELECTIVE INVESTMENTS PRESENTATION (contd)

Professor March: (contd)

positions in Selective Investment and to continue this kind of progress for the Ohio State math department.

Thank you very much. I'd be happy to answer any questions you might have.

Mr. McFerson:

Professor March, an excellent report and congratulations on what you have accomplished. I do have a question referring back to your TA education class, that you run in the summer. As Trustees, from time to time we hear complaints about the quality of teaching of TAs and it's not just directed to you, but you're the one sitting there right now.

Professor March:

Sure. I'm happy to be here.

Mr. McFerson:

I appreciate the fact that you videotape them and do the special training in the summertime before TAs teach their first class. Do you continue to follow them in the classroom? Do you find ways to get feedback from students? Do you observe them actually teaching in the classroom? Do they have an opportunity to get feedback after the first year of teaching and after they've had some real live classroom experience?

Professor March:

Yes, certainly. One of the TA support staffs' main jobs in the Autumn, Winter, and Spring Quarters is to do exactly that – follow up, visit classrooms, observe the teaching, and confer with the TA afterwards. It is also a faculty responsibility. You are probably aware of the structure of many of the large lecture courses at Ohio State, where there will be faculty lectures three days a week and smaller, TA-led recitations two days a week. Faculty are expected to visit their TAs and the TA support staff do the same, and the students give quite a bit of feedback.

When we make our evaluations of graduate students in Spring Quarter, there is academic progress, which is essentially 50 percent of the basis for evaluation, and teaching ability is the other 50 percent. So we take it very seriously.

Mr. McFerson:

Good, keep it up. Thank you.

Professor March:

Thank you.

Mr. Patterson:

Professors Zheng and March, thank you very much for your presentations this morning.

--0--

CONSENT AGENDA

President Karen A. Holbrook:

We have sixteen resolutions on the Consent Agenda today and I would like to ask that #10 -- the Appointment and Reappointment of Investment Managers -- and #13 -- the Purchase of Real Property at 650 Ackerman Road -- be considered separately. We are seeking your approval for the following:

CANCER HOSPITAL BOARD APPOINTMENTS/REAPPOINTMENT

Resolution No. 2003-112

Synopsis: Appointments and reappointment of community members to The Arthur G. James Cancer Hospital and Richard J. Solove Research Institute Board are proposed.

WHEREAS the Board of Trustees on September 1, 1993, approved the establishment of The Arthur G. James Cancer Hospital and Richard J. Solove Research Institute Board; and

WHEREAS it has been stipulated in Board of Trustees Bylaw 3335-1-03 (W) and The James Cancer Hospital and Solove Research Institute Board Bylaw 3335-109-01 that the Cancer Hospital and Research Institute Board shall be comprised of six citizens from the general public who shall be appointed by the University Board of Trustees in consultation with the President; and

WHEREAS the following named individuals have been nominated and selected for immediate appointments/reappointment to The James Cancer Hospital and Solove Research Institute Board for the terms as specified:

<u>Name</u>	<u>Term of Appointment</u>
John S. Eesley	May 14, 2003 to May 13, 2007
Edward G. Razek	May 14, 2003 to May 13, 2007
Robert B. Smith (Reappointment – 3 rd Term)	May 14, 2003 to May 13, 2007

NOW THEREFORE

BE IT RESOLVED, That the foregoing nominees be appointed and reappointed, effective immediately, as a member of The Arthur G. James Cancer Hospital and Richard J. Solove Research Institute Board for the specific terms as set forth above.

APPOINTMENTS TO THE OHIO STATE UNIVERSITY PHYSICIANS BOARD

Resolution No. 2003-113

Synopsis: Appointments to The Ohio State University Physicians Board is proposed.

WHEREAS on November 1, 2002 the Board of Trustees adopted a medical practice plan establishing a college central practice group; and

WHEREAS The Senior Vice President for Health Sciences and the Dean of the College of Medicine and Public Health has approved and designated Ohio State University Physicians (OSUP) as the college central practice group; and

WHEREAS coordination of the efforts of OSUP and the University Medical Center will help each to achieve its mission; and

APPOINTMENTS TO THE OHIO STATE UNIVERSITY PHYSICIANS BOARD (contd)

WHEREAS the appointment of two representatives from the University Medical Center to the Board of Directors of OSUP will assist in this coordination; and

WHEREAS in its Code of Regulations, OSUP has designated the senior vice president for Health Sciences and the vice president for Health Services as members of its Board of Directors:

NOW THEREFORE

BE IT RESOLVED, That R. Reed Fraley and Fred Sanfilippo are hereby authorized to serve on the Board of Directors of Ohio State University Physicians and in their capacity as a director of the OSUP are hereby authorized and instructed to represent the interest of the University as part of their official responsibilities to the University, entitling them to any immunity, insurance, or indemnity protection to which officers and employees of the University are, or hereafter may become, entitled.

**REGIONAL CAMPUS BOARDS
APPOINTMENTS/REAPPOINTMENT**

Resolution No. 2003-114

Synopsis: Approval of appointments/reappointment to The Ohio State University Regional Campus Boards is proposed.

WHEREAS the Board of Trustees in 1994 approved the establishment of The Ohio State University Regional Campus Boards; and

WHEREAS it has been previously stipulated that "the board shall be composed of eleven members appointed by The Ohio State University Board of Trustees in consultation with the president of the university" (one member of the board shall be a member of the university board of trustees; nine members shall be private citizens; and one member shall be a student); and

WHEREAS the following named persons have been nominated and selected for appointments/reappointment to the following Regional Campus Boards for the terms as specified:

Mansfield Board Appointments

John Jordan, 3-year term
Robert J. Kehoe, 3-year term
Richard D. Witchey III, 3-year term
Cynthia A. Tishue, 1-year term (student appointment)

Newark Board Appointments/Reappointment

Eschol Curl, 3-year term
Thomas J. Hall, 3-year term
David E. Railsback, 3-year term (3rd reappointment)
Angela K. Mitchell, 1-year term (student appointment)

NOW THEREFORE

BE IT RESOLVED, That the foregoing nominees be approved as members of The Ohio State University-Mansfield Board and Newark Board, effective July 1, 2003.

WAIVER AND NAMING OF GREEN SPACE

Resolution No. 2003-115

Synopsis: Approval of the Waiver of Paragraph (F) of Bylaw 3335-1-08 of Administrative Code and the commemorative naming of the green space bounded by Denney Hall on the south, Lord Hall on the east, the Science and Engineering Library to the west, and West 18th Avenue to the north, for the late Jean Hansford is proposed.

WHEREAS the Board of Trustees of The Ohio State University, did on January 9, 1976, amend paragraph (F) of bylaw 3335-1-08 of the Administrative Code to state that "buildings and structures shall not be named for any person who is an officer or employee of the University or the State of Ohio, but may be named for a person who has been retired or has otherwise left such a position for a minimum of three years"; and

WHEREAS the Board of Trustees has authority in naming of all buildings and structures at The Ohio State University, as set forth in paragraph (F) of rule 3335-1-08 of the Administrative Code; and

WHEREAS it is recommended that the Denney Hall green space, bounded by Denney Hall on the south, Lord Hall on the east, the Science and Engineering Library to the west, and West 18th Avenue to the north, be named in honor of the late Jean Hansford (B.Arch. '65) who served The Ohio State University and was steward of the University Master Plan for thirty-five years, protecting open and green spaces and helping to create additional parks and plazas on the campus; and

WHEREAS Jean Hansford was a passionate advocate for the Columbus Campus as a treasured space for current students and future generations, and directed and guided numerous projects that are reflected in the special feel of this campus – most notably the Oval and the pedestrian campus; and

WHEREAS Jean Hansford was devoted to making the campus more accessible for people, bikes, automobiles, and buses while developing policies and codes which will guide both the campus and the City of Columbus on these issues for decades to come; and

WHEREAS he was a compassionate and caring individual who devoted a great deal of his time to mentoring students on campus; and

WHEREAS Jean Hansford was a dedicated community volunteer and highly-involved citizen through activities such as the Columbus Marathon and founder of the University District Organization:

NOW THEREFORE

BE IT RESOLVED, That the applicable requirements of paragraph (F) of bylaw 3335-1-08 of the Administrative Code be waived and that the Denney Hall green space be named "Jean Hansford Quadrangle."

HONORARY DEGREE

Resolution No. 2003-116

Synopsis: The awarding of an honorary degree to David McCullough is recommended for approval.

HONORARY DEGREE (contd)

WHEREAS the Committee on Honorary Degrees and the University Senate, pursuant to rule 3335-5-488 of the Administrative Code, have approved for recommendation to the Board of Trustees awarding of an honorary degree as listed below:

David McCullough

Doctor of Humane Letters

NOW THEREFORE

BE IT RESOLVED, That the above honorary degree be awarded in accordance with the recommendation at a time convenient to the University and the recipient.

PERSONNEL ACTIONS

Resolution No. 2003-117

BE IT RESOLVED, That the personnel actions as recorded in the Personnel Budget Records of the University since the April 4, 2003 meeting of the Board, including the following Appointments, Appointment/Reappointments of Chairpersons, Reappointment of Principal Administrative Official, Leave of Absence Without Salary, Professional Improvement Leaves, and Emeritus Titles as detailed in the University Budget be approved; and

BE IT FURTHER RESOLVED, That the Medical Staff Appointments approved March 18, 2003, by The James Cancer Hospital Board, be ratified; and

BE IT FURTHER RESOLVED, That Resolution 77-92 and the provisions of the February 6, 1959 Report of the Committee on Retirement and Insurance, be waived to allow for the reappointment of Carole A. Anderson as Vice Provost for Academic Administration.

Appointments

Name: ROBERT W. BRUEGGEMEIER
Titles: Dean/Professor
College: Pharmacy
Term: July 1, 2003, through June 30, 2008

Name: RICHARD R. FREEMAN
Titles: Dean/Distinguished Professor
College: Mathematical and Physical Sciences
Term: August 1, 2003, through June 30, 2008
Present Position: Edward Teller Professor and Chair, Department of Applied Science, University of California at Davis, Davis, CA

Name: MARY E. WEWERS
Title: Professor (The Mildred E. Newton Professorship)
College: Nursing
Term: July 1, 2003, through June 30, 2007

Appointment of Chairperson

January 1, 2003, through December 31, 2003

Materials Science and Engineering

David A. Rigney*

*Interim

PERSONNEL ACTIONS (contd)

Reappointment of Chairpersons

July 1, 2003, through June 30, 2004

Art

Ardine K. Nelson*

October 1, 2003, through September 30, 2007

French and Italian

Diane W. Birckbichler

*Interim

Reappointment of Principal Administrative Official

CAROLE A. ANDERSON, Vice Provost for Academic Administration, Office of Academic Affairs, effective July 1, 2003, pursuant to rule 3335-1-03 (R) of the Administrative Code.

Leave of Absence Without Salary

CHRISTA VAN WIJNBERGEN, Assistant Professor, Department of Political Science, effective Autumn Quarter 2003, Winter Quarter and Spring Quarter 2004 to accept a fellowship at the Minda de Gunzburg Center for European Studies at Harvard University.

Leave of Absence Without Salary -- Continuation

GEORGE A. ALESSANDRIA, Assistant Professor, Department of Economics, effective Autumn Quarter 2003, Winter Quarter and Spring Quarter 2004, to accept a visiting assistant professorship in The Finance Department at The Wharton School, Philadelphia, PA.

Professional Improvement Leaves

JAMES R. BARTHOLOMEW, Professor, Department of History, effective Autumn Quarter 2003, Winter Quarter and Spring Quarter 2004.

CECIL M. FYLE, Professor, Department of African American and African Studies, effective Autumn Quarter 2003, Winter Quarter and Spring Quarter 2004.

MARILYN A. JOHNSTON, Professor, School of Teaching and Learning, effective Autumn Quarter 2003, Winter Quarter and Spring Quarter 2004.

JEREDITH J. MERRIN, Professor, Department of English, effective Autumn Quarter 2003 and Winter Quarter 2004.

MICHAEL D. SWARTZ, Professor, Department of Near Eastern Languages and Cultures, effective Autumn Quarter 2003, Winter Quarter and Spring Quarter 2004.

HARRY VREDEVELD, Professor, Department of Germanic Languages and Literatures, effective Autumn Quarter 2003, Winter Quarter and Spring Quarter 2004.

ANGELA K. BRINTLINGER, Associate Professor, Department of Slavic and East European Languages and Literatures, effective Autumn Quarter 2003, Winter Quarter and Spring Quarter 2004.

ELIZABETH B. DAVIS, Associate Professor, Department of Spanish and Portuguese, effective Autumn Quarter 2003, Winter Quarter and Spring Quarter 2004.

PERSONNEL ACTIONS (contd)

Professional Improvement Leaves (contd)

BRIAN W. EDMISTON, Associate Professor, School of Teaching and Learning, effective Autumn Quarter 2003, Winter Quarter and Spring Quarter 2004.

PATRICIA E. ENCISO, Associate Professor, School of Teaching and Learning, effective Autumn Quarter 2003, Winter Quarter and Spring Quarter 2004.

MARY M. FONOW, Associate Professor, Department of Women's Studies, effective Autumn Quarter 2003, Winter Quarter and Spring Quarter 2004.

JEAN-FRANCOIS FOURNY, Associate Professor, Department of French and Italian, effective Autumn Quarter 2003 and Winter Quarter 2004.

REBECCA L.C. HAIDT, Associate Professor, Department of Spanish and Portuguese, effective Winter Quarter 2004.

MICHELLE R. HERMAN, Associate Professor, Department of English, effective Winter Quarter 2004.

EUGENE W. HOLLAND, Associate Professor, Departments of French and Italian and Comparative Studies, effective Autumn Quarter 2004, Winter Quarter and Spring Quarter 2005.

HOWARD J. KLEIN, Associate Professor, Department of Management and Human Resources, effective Autumn Quarter 2003, Winter Quarter and Spring Quarter 2004.

KITTY O. LOCKER, Associate Professor, Department of English, effective Autumn Quarter 2003, Winter Quarter and Spring Quarter 2004.

DOROTHY P. NOYES, Associate Professor, Department of English, effective Autumn Quarter 2003, Winter Quarter and Spring Quarter 2004.

CHAN E. PARK, Associate Professor, Department of East Asian Languages and Literatures, effective Autumn Quarter 2003, Winter Quarter and Spring Quarter 2004.

DIANE M. SAINATO, Associate Professor, School of Physical Activity and Educational Services, effective Spring Quarter 2004.

RANDALL L. SCHWELLER, Associate Professor, Department of Political Science, effective Autumn Quarter 2003 and Winter Quarter 2004.

FEI-RAN TIAN, Associate Professor, Department of Mathematics, effective Autumn Quarter 2003, Winter Quarter and Spring Quarter 2004.

Emeritus Titles

CHARLES A. EBNER, Department of Physics, with the title Professor Emeritus, effective July 1, 2003.

OSAMU FUJIMURA, Department of Speech and Hearing Science, with the title Professor Emeritus, effective July 1, 2003.

ROBERT GOLD, Department of Mathematics, with the title Professor Emeritus, effective July 1, 2003.

HERMAN A. TOLBERT, Department of Psychiatry, with the title Professor Emeritus, effective July 1, 2003.

PERSONNEL ACTIONS (contd)

Emeritus Titles (contd)

ROBERT D. FLEMING, Ohio State University Extension, with the title Associate Professor Emeritus, effective July 1, 2003.

TIMOTHY W. KAHRL, Department of English (Mansfield Campus), with the title Assistant Professor Emeritus, effective July 1, 2003.

NANCY S. WARDWELL, School of Physical Activity and Educational Services, with the title Assistant Professor Emeritus, effective July 1, 2003.

Medical Staff Appointments (The Arthur G. James Cancer Hospital and Richard J. Solove Research Institute)

February/March 2003

Medical and Associate Staff Appointments

Rupa Ghosh-Berkebile, C.N.P., Allied Health Professional, Hematology/Oncology, James Internal Medicine, 2/14/03 – 6/30/03

Ahmad M. Jadaan, M.D., James Associate Attending, James Internal Medicine, General Medicine, 3/18/03 – 6/30/03

Robert G. Kloos, D.O., James Associate Attending, James Surgery, General/Vascular, 2/14/03 – 6/30/03

Gunwant S. Mallik, M.D., James Associate Attending, James Surgery, Neurosurgery, 3/18/03 – 9/8/03

Tibor Nadasdy, M.D., James Associate Attending, James Pathology, James Pathology, 2/14/03 – 8/4/03

Richard E. Schlanger, M.D., James Associate Attending, James Surgery, General Surgery, 2/14/03 – 8/4/03

Shantanu Sinha, M.D., James Community Associate, James Internal Medicine, Cardiology, 2/14/03 – 8/4/03

Aline V. Wang, M.D., James Associate Attending, James Anesthesiology, 3/18/03 – 9/8/03

Provisional to Full Appointments

Anath Annamraju, M.D., James Community Associate, James Surgery, Urologic Surgery, 2/14/03 – 6/30/03

James R. Bruno, D.M.D., M.D., James Associate Attending, James Surgery, Plastic Surgery, 3/18/03 – 6/30/03

Phillip Calendine, M.D., James Associate Attending, James Radiology, 2/14/03 – 6/30/03

Dongwoo Chang, M.D., James Associate Attending, James Surgery, Neurosurgery, 2/14/03 – 6/30/03

Lisa R. Dunn- Albanese, M.D., James Associate Attending, James OB/GYN, 3/18/03 – 6/30/03

Lisa S. Gaines, D.O., James Associate Attending, James Anesthesiology, 3/18/03 – 6/30/03

Arun Gowdamarajan, M.D., James Associate Attending, James Surgery, General Surgery, 2/14/03 – 6/30/03

Thomas C. Keeling, M.D., James Community Associate, James Internal Medicine, Infectious Diseases, 3/18/03 – 6/30/03

Vlada Mardovin, M.D., James Community Associate, James Surgery, Urologic Surgery, 2/14/03 – 6/30/04

Virginia McGrath, M.D., James Associate Attending, James Surgery, General Surgery, 2/14/03 – 6/30/04

Kenneth Morgenstern, M.D., James Associate Attending, James Ophthalmology, 2/14/03 – 6/30/04

Kumar Mukerjee, M.D., James Community Associate, James Internal Medicine, Digestive Diseases, 2/14/03 – 6/30/04

PERSONNEL ACTIONS (contd)

Medical Staff Appointments (The Arthur G. James Cancer Hospital and Richard J. Solove Research Institute) (contd)

February/March 2003 (contd)

Provisional to Full Appointments (contd)

Marios Panayides, M.D., James Community Associate, James Surgery, General Surgery, 2/14/03 – 6/30/04

Steven Patterson, D.O., James Community Associate, James OB/GYN, 2/14/03 – 6/30/04

Robert J. Ragosin, M.D., James Associate Attending, James Radiology, 3/18/03 – 6/30/04

Abhik Ray-Chaudhury, James Associate Attending, James Pathology, 2/14/03 – 6/30/04

Joel H. Saltz, M.D., Ph.D., James Associate Attending, James Pathology, 3/18/03 – 6/30/04

Jason Sayat, M.D., James Clinical Attending, James OB/GYN, 2/14/03 – 6/30/04

Ramalingam Selvarajah, M.D., James Community Associate, James Family Medicine, 2/14/03 – 6/30/04

Bivik R. Shah, M.D., James Clinical Attending, James Surgery, Plastic Surgery, 2/18/03 – 6/30/04

Joel Shockley, M.D., James Associate Attending, James Radiology, 2/14/03 – 6/30/04

Kelly A. Slavens, C.N.P., Allied Health Professional, James Internal Medicine/Hematology/Oncology, 3/18/03 – 6/30/04

Dennis Sullivan, M.D., James Community Associate, James Neurology, 2/14/03 – 6/30/04

Salvador B. Trinidad, M.D., James Community Associate, James Radiology, 3/18/03 – 6/30/04

Khariat Uddin, M.D., James Community Associate, James Internal Medicine, General Medicine, 2/14/03 – 6/30/04

Meade van Putten, D.D.S., James Associate Attending, James Dentistry, James Dentistry, 2/14/03 – 6/30/04

Wm. Vazquez-Choisne, M.D., James Community Associate, James Radiology, 2/14/03 – 6/30/04

Eric S. Ward, M.D., James Clinical Attending, James Surgery, Urologic Surgery, 3/18/03 – 6/30/04

Christopher L. Yerington, M.D., James Associate Attending, James Anesthesiology, 3/18/03 – 6/30/04

Joseph Zaki, M.D., James Associate Attending, James Anesthesiology, 2/14/03 – 6/30/04

Requests for Additional Privilege

Susan Ezzone, C.N.P., Allied Health Professional, James Internal Medicine, Prescriptive Authority, 3/18/03 – 6/30/03

Howard Paskett, P.A., Allied Health Professional, James Orthopaedics, Surgical First Assist, 2/14/03 – 7/7/03

* Those with last names beginning with A-L reappoint in 2003

RESOLUTIONS IN MEMORIAM

Resolution No. 2003-118

Synopsis: Approval of Resolutions in Memoriam is proposed.

RESOLVED, That the Board adopt the following Resolutions in Memoriam and that the President be requested to convey a copy to the families of the deceased.

RESOLUTIONS IN MEMORIAM (contd)

Timothy D. Moore

The Board of Trustees of The Ohio State University expresses its sorrow upon the death on March 5, 2003, of Timothy D. Moore, Administrator and Clinical Professor at the Medical Center and College of Pharmacy.

Professor Moore received his Bachelor of Pharmacy degree from Washington State University in 1972. Following completion of a residency in clinical pharmacy practice at Washington State University in 1973, he joined the faculty and staff at The Ohio State University Hospitals and College of Pharmacy. He completed his Master of Science degree, and an ASHP accredited residency at The Ohio State University in 1979. During his 30 years with the University, he was also appointed as a faculty member in the Department of Family Medicine and achieved the rank of clinical professor in both the Colleges of Medicine and Public Health and Pharmacy.

Through his career at OSU Professor Moore assumed increasing administrative responsibility within the College of Pharmacy, eventually becoming senior director of pharmaceutical services. He was appointed to several hospital administrative positions within the Medical Center: including opening of The Arthur G. James Cancer Hospital and Research Institute, acting as administrative director for patient care services, developing and opening the Medical Center's Home Health Care program, overseeing more than 25 primary care physician offices and University Hospitals Clinics, and integrating the first community hospital into the OSU medical care system. He led the integration of the former Harding Hospital with the OSU Department of Psychiatry. He was chief administrative officer of OSU and Harding Behavioral Healthcare and Medicine and administrator of University Psychiatric Physicians, Inc. Last year, he was honored as the first recipient of the Richard B. Davies, M.D. Award for his efforts in integrating these behavioral healthcare programs. Most recently he acted as associate executive director of OSU and Harding Behavioral Health and administrator of the practice plan for the Department of Psychiatry.

In addition to his pharmacy practice and administrative responsibilities, Professor Moore continued to teach classes at the Colleges of Pharmacy and Medicine and Public Health, and authored and co-authored more than 100 publications on topics in pharmacy and hospital-related matters. He was an invited speaker at local, national, and international levels and served as a reviewer for a number of professional publications. Professor Moore was particularly well known in the professional community for his participation in the development of the *Pharmaceutical Educational Network*. This educational cable and satellite television series, for which he was the content specialist, provided information about more than 200 new drugs since the series began. It has been broadcast throughout the Midwest and to over 1,800 hospitals nationwide. The series has been an eight-time winner of the Communicator Award, has received a regional Emmy Award nomination, and was recently awarded the coveted Telly Award. In addition to his academic and hospital activities, Professor Moore was an active participant in his profession, having served as president of both the Central Ohio Society of Health-System Pharmacists and the Ohio Society of Health-System Pharmacists. He was appointed by the Governor of the State of Ohio to two four-year terms on the Ohio State Board of Pharmacy. During those terms he twice served as the Board's president.

On behalf of the University community, the Board of Trustees expresses to the family of Professor Timothy D. Moore its deepest sympathy and sense of understanding of their loss. It was directed that this resolution be inscribed upon the minutes of the Board of Trustees, and that a copy be tendered to his family as an expression of the Board's heartfelt sympathy.

Glenn O. Schwab

The Board of Trustees of The Ohio State University expresses its sorrow upon the death on March 12, 2003, of Glenn O. Schwab, Professor Emeritus in the Department of Food, Agricultural, and Biological Engineering.

RESOLUTIONS IN MEMORIAM (contd)

Glenn O. Schwab (contd)

Professor Schwab held a Bachelor of Agricultural Engineering degree from Kansas State University, and a Master of Science and Doctor of Philosophy degrees in agricultural engineering from Iowa State University. He was a veteran of World War II. He taught at Iowa State University before coming to The Ohio State University in 1956. Professor Schwab taught and conducted research in the Department of Agricultural Engineering (currently Department of Food, Agricultural, and Biological Engineering) for over 29 years. He received the Ralph L. Boyer Award and the Armington Award for Meritorious Service from The Ohio State University College of Engineering in 1971 and 1973, respectively. He was responsible for establishing the Overholt Drainage Education and Research Program and the International Program for Water Management in Agriculture that are both still housed in the Department of Food, Agricultural, and Biological Engineering. He also established The Glenn O. and Lois S. Schwab Scholarship Fund in this department.

Professor Schwab served as a Fulbright-Hays lecturer at the University of Ljubiana, Yugoslavia, in 1978, and as an adviser and consultant in New Zealand, India, Pakistan, and Nigeria on soil and water conservation issues. Among his numerous publications, he authored four textbooks, two of which were translated for use internationally. Dr. Schwab contributed significantly to the education of many scientists and engineers, and many of his graduate students have attained national and international positions of leadership and esteem that reflect the superior technical training they received.

Dr. Schwab served his profession at the highest level. He was a member and fellow of the American Society of Agricultural Engineers where he served in a number of leadership roles. In 1968, he received the Hancor Soil and Water Engineering Award for noteworthy contributions to the advancement of soil and water engineering, and in 1987 the John Deere Gold Medal Award for "Distinguished Achievement in the Application of Science and Art to the Soil." In 1983, he was inducted into the Overholt Drainage Hall of Fame.

Glenn Schwab was an active member of the University community and served on numerous department, college, and University committees. He was a highly respected and admired colleague of all who knew and worked with him.

On behalf of the University community, the Board of Trustees expresses to the family of Professor Glenn O. Schwab its deepest sympathy and sense of understanding of their loss. It was directed that this resolution be inscribed upon the minutes of the Board of Trustees and that a copy be tendered to his family as an expression of the Board's heartfelt sympathy.

REPORT OF RESEARCH CONTRACTS AND GRANTS

Resolution No. 2003-119

Synopsis: The reports on research and other sponsored program contracts and grants and the summary for March 2003 are presented for Board acceptance.

WHEREAS monies are solicited and received on behalf of the University from governmental, industrial, and other agencies in support of research, instructional activities, and service; and

WHEREAS such monies are received through The Ohio State University Research Foundation:

NOW THEREFORE

REPORT OF RESEARCH CONTRACTS AND GRANTS (contd)

BE IT RESOLVED, That the research agreement between The Ohio State University and The Ohio State University Research Foundation for the contracts and grants reported herein during the month of March 2003 be approved.

President Holbrook:

Also, I would like to mention the monthly Report on University Development has the addition of The James F. Patterson Land-Grant University Lectureship Fund, that the Board is establishing with generous gifts from the Nationwide Foundation, the Ohio Farm Bureau, current and past members of the Board, and friends and colleagues of Jim Patterson. This endowment fund will honor and recognize Jim's deep commitment to Ohio State being a vibrant university and fulfilling its land-grant mission in an ever-changing world.

Mr. Patterson:

Just on a personal note, I cannot think of anything that the Board could have done that would have made me happier than this lectureship. Land-grant universities and their continuation are of particular interest to me and it will give me a chance to come to Columbus once a year to hear the lectures.

REPORT ON UNIVERSITY DEVELOPMENT

Resolution No. 2003-120

Synopsis: The report on the receipt of gifts and the summary for March 2003 are presented for Board acceptance.

WHEREAS monies are solicited and received on behalf of the University from alumni, industry, and various individuals in support of research, instructional activities, and service; and

WHEREAS such gifts are received through The Ohio State University Development Fund and The Ohio State University Foundation; and

WHEREAS this report includes the establishment of the Herschel and Suzanne Meredith Endowed Graduate Fellowship in the Fisher College of Business; and

WHEREAS this report includes the establishment of ten (10) new named endowed funds and the amendment of one (1) named endowed funds:

NOW THEREFORE

BE IT RESOLVED, That the acceptance of the report from The Ohio State University Development Fund and The Ohio State University Foundation during the month of March 2003 be approved.

REPORT ON UNIVERSITY DEVELOPMENT (contd)

TOTAL UNIVERSITY PRIVATE SUPPORT

July through March
2002-03 Compared to 2001-02

GIFT RECEIPTS BY DONOR TYPE

	Dollars July through March		
	<u>2002-03</u>	<u>2001-02</u>	<u>%Change</u>
Individuals:			
Alumni (Current Giving)	\$29,111,570	\$26,715,975	9
Alumni (From Bequests)	<u>3,402,488</u>	<u>4,046,255</u>	(16)
Alumni Total	\$32,514,058	\$30,762,230	6
Non-Alumni (Current Giving)	\$14,943,821	\$12,842,030	16
Non-Alumni (From Bequests)	<u>3,958,259</u>	<u>2,798,230</u>	41
Non-Alumni Total	\$18,902,080	\$15,640,260	21
Individual Total	\$51,416,138	\$46,402,490	11 ^A
Corporations/Corp/Foundations	\$31,116,375	\$33,050,632	(6)
Private Foundations	\$15,150,939	\$15,239,640	(1)
Associations and Other Organizations	<u>\$5,780,223</u>	<u>\$3,394,610</u>	70 ^B
Total	\$103,463,675	\$98,087,372	5

NOTES

A Individual giving is up 11% largely due to the fact that gifts of \$10,000 or more are up 16% (398 gifts for \$30.5 million last year; 455 gifts for \$35.7 million this year).

B Giving from associations and other organizations at the \$10,000 or more level is up 70% for July- March of the fiscal year (\$4.4 million from 76 gifts this year; \$2.1 million from 74 gifts last year).

REPORT ON UNIVERSITY DEVELOPMENT (contd)

TOTAL UNIVERSITY PRIVATE SUPPORT (contd)

July from March
2002-03 Compared to 2001-02

GIFT RECEIPTS BY PURPOSE

	Dollars July through March		
	<u>2002-03</u>	<u>2001-02</u>	<u>% Change</u>
Gift Receipts to Current Use and Endowment Funds:			
Buildings/Equipment	\$17,720,061	\$16,773,214	6
Faculty Support	\$9,477,837	\$10,346,272	(7)
Program Support	\$56,708,730	\$53,045,925	7
Student Financial Aid	\$13,427,916	\$10,447,172	29
Annual Funds-Colleges/Departments	\$5,290,222	\$6,472,111	(18)
Annual Funds-University	<u>\$838,909</u>	<u>\$1,002,678</u>	(16)
Total	\$103,463,675	\$98,087,372	5

GIFT ADDITIONS TO ENDOWMENT

Dollars
July through March

<u>2002-03</u>	<u>2001-02</u>	<u>% Change</u>
\$32,176,228	\$32,304,772	0

REPORT ON UNIVERSITY DEVELOPMENT (contd)

THE OHIO STATE UNIVERSITY DEVELOPMENT FUND

	<u>Previous Gifts</u>	<u>Current Gifts</u>	<u>Total Gifts</u>
<u>Establishment of Named Endowed Funds</u>			
The Cartoon Research Library Program Endowment Fund (Used to support operations, programs, and exhibitions of the Cartoon Research Library; provided by gifts from library friends and donors)		\$35,333.00	\$35,333.00
The Edith Cockins Fund (Used to recognize outstanding accomplishments by employees of the Office of the University Registrar; provided by gifts from various friends of the University and the class of 1916)		\$26,622.00	\$26,622.00

THE OHIO STATE UNIVERSITY FOUNDATION

	<u>Previous Gifts</u>	<u>Current Gifts</u>	<u>Total Gifts</u>
<u>Establishment of Named Fellowship</u>			
Herschel and Suzanne Meredith Endowed Graduate Fellowship in the Fisher College of Business (Used to provide fellowships to M.B.A. students with no other form of financial aid; provided by gifts from Herschel T. Meredith)		\$500,000.00	\$500,000.00
<u>Establishment of Named Endowed Funds</u>			
James B. and Harriett Beard Graduate Fellowship Fund in Turfgrass Physiology/Biochemistry (Used to provide support for graduate fellowships for Masters- or Ph.D.-level students enrolled in the study and research of turfgrass; provided by gifts from Harriett and James B. Beard)		\$155,117.20	\$155,117.20
Ice Core Paleoclimate Research Endowment Fund (Used to provide support for the efforts of the ice core research group; provided by funds received from the 2002 Dr. A.H. Heinken Prize for Environmental Sciences)		\$150,000.00	\$150,000.00
Dr. Frank L. Himes Associateship in Soil Science Fund (Used to provide support for undergraduate or graduate students assisting in teaching of soil sciences courses; provided by a gift from John D. Watson)		\$52,731.28	\$52,731.28

REPORT ON UNIVERSITY DEVELOPMENT (contd)

THE OHIO STATE UNIVERSITY FOUNDATION (contd)

	<u>Previous Gifts</u>	<u>Current Gifts</u>	<u>Total Gifts</u>
<u>Establishment of Named Endowed Funds (contd)</u>			
Garth W. Volk Associateship in Soil Science Fund (Used to support undergraduate and graduate students employed on special projects related to administration of the School of Natural Resources; provided by a gift from John D. Watson)		\$51,506.29	\$51,506.29
Carroll County 4-H Endowment Fund (Used to support the Carroll County 4-H Youth Development Program; provided by gifts from friends of Carroll County 4-H)		\$25,100.00	\$25,100.00
Washington County 4-H Endowment Fund (Used to support the Washington County 4-H Youth Development Program; provided by gifts from friends of Washington County 4-H)		\$25,000.00	\$25,000.00
The Jacquelyn L. Wells Endowment Fund in Ovarian Cancer Research (Used to support ovarian cancer research programs at the Comprehensive Cancer Center – The Arthur G. James Cancer Hospital and Richard J. Solove Research Institute; provided by a gift from William D. Wells)		\$25,000.00	\$25,000.00
The James F. Patterson Land-Grant University Lectureship Fund (Used to support an annual lectureship and to bring to campus annually a prominent lecturer to speak to the range of challenges facing land-grant institutions; provided by gifts from The Ohio State University Board of Trustees, the Nationwide Foundation, the Ohio Farm Bureau Federation, and friends)			
<u>Change in Description of Named Endowed Fund</u>			
The Paul A. and Betty L. Whittington Endowed Scholarship Fund			
Total		<u>\$1,046,409.77</u>	<u>\$1,046,409.77</u>

REPORT ON UNIVERSITY DEVELOPMENT (contd)

THE OHIO STATE UNIVERSITY DEVELOPMENT FUND

Establishment of Named Endowed Funds

The Cartoon Research Library Program Endowment Fund

The Cartoon Research Library Program Endowment Fund was established May 2, 2003, by the Board of Trustees of The Ohio State University with gifts from library friends and donors.

All gifts are to be invested in the University's Permanent Endowment Fund, under the rules and regulations adopted by the Board of Trustees of The Ohio State University, with the right to invest and reinvest as occasion dictates.

The annual income shall be used to support operations, programs, and exhibitions of the Cartoon Research Library.

It is the desire of the donors that this fund should benefit the University in perpetuity. If the need for this fund should cease to exist or so diminish as to provide unused income, then another use shall be designated by the Board of Trustees in consultation with the director of the University Libraries and head curator for the Cartoon Research Library in order to carry out the desire of the donors.

\$35,333.00

The Edith Cockins Fund

The Edith Cockins Fund was established May 2, 2003, by the Board of Trustees of The Ohio State University, with gifts from various friends of the University and the Class of 1916.

All gifts to the University are to be invested in the University's Permanent Endowment Fund, under the rules and regulations adopted by the Board of Trustees of The Ohio State University, with the right to invest and reinvest as occasion dictates.

Members of the Class of 1916 created the fund in recognition of Ms. Cockins (1873 – 1963), Class of 1894, who became the first University registrar of The Ohio State University in 1895 and served in this role until her retirement in 1944.

The purpose of the fund is to recognize outstanding accomplishments by employees of the Office of the University Registrar at The Ohio State University. The income shall be used at the discretion of the University registrar to recognize one or more outstanding employees each year. Any income remaining at the end of the fiscal year should be reinvested into the principal.

It is the desire of the donor that this fund should benefit the University in perpetuity. If the need for this fund should cease to exist or so diminish as to provide unused income, than another use shall be designated by the Board of Trustees as recommended by the person or unit with spending authority and/or appropriate University official in order to carry out the desire of the donor. Any alternative use will be in conjunction with the original purpose of the gift.

\$26,622.00

REPORT ON UNIVERSITY DEVELOPMENT (contd)

THE OHIO STATE UNIVERSITY FOUNDATION

Establishment of Named Fellowship

Herschel and Suzanne Meredith Endowed Graduate Fellowship
in the Fisher College of Business

The Herschel and Suzanne Meredith Endowed Graduate Fellowship in the Fisher College of Business was established May 2, 2003, in accordance with the guidelines approved by the Board of Directors of The Ohio State University Foundation, with gifts designated for support of The Max M. Fisher College of Business from contributions from Herschel T. Meredith.

All gifts are to be invested by the Foundation, under the rules and regulations adopted by the Foundation's Board of Directors, with the right to invest and reinvest as occasion dictates.

The annual income shall be used to provide a fellowship(s) to a Master of Business Administration student(s) with no other form of financial aid. Selection of the recipients shall be made by the dean of the Fisher College of Business with recommendation made by the Fisher College academic director of the M.B.A. program.

It is the desire of the donors that this fund should benefit the University in perpetuity. If the need for this fund should cease to exist or so diminish as to provide unused income, then another use shall be designated by the Foundation Board in consultation with the appropriate college dean, department chairperson, or program administrative officer in order to carry out the desire of the donors.

\$500,000.00

Establishment of Named Endowed Funds

James B. and Harriet Beard Graduate Fellowship Fund
in Turfgrass Physiology/Biochemistry

The James B. and Harriet Beard Graduate Fellowship Fund in Turfgrass Physiology/Biochemistry was established May 2, 2003, in accordance with the guidelines approved by the Board of Directors of The Ohio State University Foundation, with gifts from Harriet and James B. Beard (B.S.Agr., 1957), family, friends, and industry leaders.

All gifts are to be invested by the Foundation, under the rules and regulations adopted by the Foundation's Board of Directors, with the right to invest and reinvest as occasion dictates.

The fund is being established for the purpose of conducting research in the area of turfgrass physiology/biochemistry with emphasis on plant stress. High priority is to be given to attracting high quality graduate students. The objective of the graduate fellowship will be to conduct research at either the molecular or whole plant level to provide better insight into how turfgrass plants respond to stresses induced by biotic or abiotic factors. The long-term results of this research will be the development of efficient and optimum cultural practices.

The annual income shall be used to support one or more graduate fellowships for Masters- or Ph.D.-level students. Support shall provide tuition and fees for high quality graduate students who are or will be enrolled in the study and research of turfgrass physiology/biochemistry with emphasis on plant stress. Selection of the fellowship recipients will be made by the vice president for Agricultural Administration and University Outreach, and executive dean for Food, Agricultural, and Environmental Sciences or his designees, in consultation with the graduate committee of the department in which the student is registered, the turfgrass faculty, the Graduate School, and the University Committee on Student Financial Aid.

REPORT ON UNIVERSITY DEVELOPMENT (contd)

THE OHIO STATE UNIVERSITY FOUNDATION (contd)

Establishment of Named Endowed Funds (contd)

James B. and Harriet Beard Graduate Fellowship Fund
in Turfgrass Physiology/Biochemistry (contd)

It is the desire of the donors that this fund should benefit the University in perpetuity. If the need for this fund should cease to exist or so diminish as to provide unused income, then another use shall be designated by the Foundation Board in consultation with the vice president for Agricultural Administration and University Outreach, and executive dean for Food, Agricultural, and Environmental Sciences or his successor, the turfgrass faculty and chairpersons of the Departments of Horticulture and Crop Science, Plant Pathology, and Entomology, and the director of the School of Natural Resources.

\$155,117.20

Ice Core Paleoclimate Research Endowment Fund

The Ice Core Paleoclimate Research Endowment Fund was established May 2, 2003, in accordance with the guidelines approved by the Board of Directors of The Ohio State University Foundation, with funds received from the 2002 Dr. A.H. Heineken Prize for Environmental Sciences awarded to Dr. Lonnie G. Thompson (M.S., 1973; Ph.D., 1976) of Columbus, Ohio.

All gifts are to be invested by the Foundation, under the rules and regulations adopted by the Foundation's Board of Directors, with the right to invest and reinvest as occasion dictates.

The Ice Core Paleoclimate Research Endowment Fund is being established to support current and future research activities of the ice core paleoclimate research group at The Ohio State University. The principle objectives of the fund are to support: (1) the acquisition of a global array of ice cores that provide high-resolution climatic and environmental histories; and (2) the preservation of the frozen ice core archive in storage facilities at The Ohio State University for future study.

The annual income shall be used to support the efforts of the ice core research group, including students engaged in this research. All expenditures shall be initiated at the discretion of Dr. Lonnie G. Thompson, Distinguished University Professor in the Department of Geological Sciences, or his successor, with the approval of the chairperson of the Department of Geological Sciences and the dean of the College of Mathematical and Physical Sciences.

In the event of a funding shortfall for the ice core research paleoclimate group, an equipment emergency, or the occurrence of an unanticipated field opportunity that is deemed critical for the long-term mission of the ice core paleoclimate research group, the principal balance of this fund may be invaded to support such emergency expenses.

It is the desire of the donors that this fund should benefit the University in perpetuity. If the Ice Core Paleoclimate Research Group should cease to exist at some future date, the proceeds from this fund shall then be used for the support and maintenance of the frozen archive. Should, at some point in the distant future, the maintenance of the OSU ice core archive no longer be necessary, then it is the desire of the donors that the remaining funds should be distributed, in equal increments, to the Byrd Polar Research Center and the Department of Geological Sciences in order to establish two new endowments at the discretion of the corresponding director, chairperson, or program administrative officer.

\$150,000.00

REPORT ON UNIVERSITY DEVELOPMENT (contd)

THE OHIO STATE UNIVERSITY FOUNDATION (contd)

Establishment of Named Endowed Funds (contd)

Dr. Frank L. Himes Associateship in Soil Science Fund

The Dr. Frank L. Himes Associateship in Soil Science Fund was established May 2, 2003, in accordance with the guidelines approved by the Board of Directors of The Ohio State University Foundation, with a gift from John D. Watson (B.S. Agronomy, 1963; M.S. Agronomy, 1967) of Hilliard, Ohio. The gift was made to honor his former faculty member, Frank L. Himes, who challenged him and fellow students with his innovative classroom and laboratory instruction; and to strengthen the teaching experiences of students enrolled in the soil science field.

All gifts are to be invested by the Foundation, under the rules and regulations adopted by the Foundation's Board of Directors, with the right to invest and reinvest as occasion dictates.

The annual income shall be used to support undergraduate (first preference) or graduate students assisting in teaching of soil sciences courses or their successors. The funding is intended to encourage experience with and/ or development of innovative teaching methods and techniques. Uses shall include financial support, wages, or graduate assistantships for students. The director of the School of Natural Resources or his designee shall direct the use of the fund. Scholarships will be awarded in consultation with the University Committee on Student Financial Aid.

It is the desire of the donor that this fund should benefit the University in perpetuity. If the need for this fund should cease to exist or so diminish as to provide unused income, then another use shall be designated by the Foundation Board in consultation with the vice president for Agricultural Administration and University Outreach, and executive dean for Food, Agricultural, and Environmental Sciences, and the director of the School of Natural Resources, or their successors in order to carry out the desire of the donor.

\$52,731.28

Garth W. Volk Associateship in Soil Science Fund

The Garth W. Volk Associateship in Soil Science Fund was established May 2, 2003, in accordance with the guidelines approved by the Board of Directors of The Ohio State University Foundation, with a gift from John D. Watson (B.S. Agronomy, 1963; M.S. Agronomy, 1967) of Hilliard, Ohio. John's gift was made to honor Dr. G. W. Volk, former chairperson of the Department of Agronomy (now part of the Department of Horticulture and Crop Science), and a close faculty mentor for him. Dr. Volk provided clear counsel and sincere sympathetic understanding to students and faculty while providing long-term leadership to the Department of Agronomy.

All gifts are to be invested by the Foundation, under the rules and regulations adopted by the Foundation's Board of Directors, with the right to invest and reinvest as occasion dictates.

Criteria for the associateship to be awarded to a graduate or undergraduate student include: academic achievement with a minimum cumulative GPA of 3.5, sound moral character, speaking ability, and a potential for administrative responsibilities.

The annual income shall be used to support undergraduate or graduate students employed on special projects related to administration of the School of Natural Resources or its successor. The recipient shall work closely with a mentor and prepare a written/oral presentation upon conclusion of the project. Each project will be selected to meaningfully contribute to the School and to the awardee and be commensurate in size with resources available. The director of the School of Natural Resources or his designee shall direct the use of the fund and select the

REPORT ON UNIVERSITY DEVELOPMENT (contd)

THE OHIO STATE UNIVERSITY FOUNDATION (contd)

Establishment of Named Endowed Funds (contd)

Garth W. Volk Associateship in Soil Science Fund (contd)

recipient. Scholarships will be awarded in consultation with the University Committee on Student Financial Aid.

Potential recipients will submit an application including name, address, evidence of speaking and administrative ability, and a one-page essay explaining career goals. The recipient will receive a certificate indicating the award and their name will be placed on a plaque listing names of all recipients over time.

It is the desire of the donor that this fund should benefit the University in perpetuity. If the need for this fund should cease to exist or so diminish as to provide unused income, then another use shall be designated by the Foundation Board in consultation with the vice president for Agricultural Administration and University Outreach, and executive dean for Food, Agricultural, and Environmental Sciences, and the director of the School of Natural Resources or their successors in order to carry out the desire of the donor.

\$51,506.29

Carroll County 4-H Endowment Fund

The Carroll County 4-H Endowment Fund was established May 2, 2003, in accordance with the guidelines approved by the Board of Directors of The Ohio State University Foundation, with current and future gifts from friends of Carroll County 4-H.

All gifts are to be invested by the Foundation, under the rules and regulations adopted by the Foundation's Board of Directors, with the right to invest and reinvest as occasion dictates.

The annual income shall be used to support the Carroll County 4-H Youth Development Program. This support may include, but is not limited to: the funding of scholarships and awards for 4-H members, volunteer leaders, and friends of 4-H; sponsoring seminars and programs; and purchasing materials or services that will supplement 4-H programming or increase the visibility and public support for 4-H in Carroll County. All expenditures from this fund shall be approved by the Carroll County 4-H Committee and the professional providing leadership to the Carroll County 4-H program.

It is the desire of the donors that this fund should benefit the University in perpetuity. If the need for this fund should cease to exist or so diminish as to provide unused income, then another use shall be designated by the Foundation Board in consultation with the director for Ohio State University Extension and a committee representing the Carroll County 4-H donors, in order to carry out the desire of the donors.

\$25,100.00

Washington County 4-H Endowment Fund

The Washington County 4-H Endowment Fund was established May 2, 2003, in accordance with the guidelines approved by the Board of Directors of The Ohio State University Foundation, with current and future gifts from friends of Washington County 4-H.

All gifts are to be invested by the Foundation, under the rules and regulations adopted by the Foundation's Board of Directors, with the right to invest and reinvest as occasion dictates.

REPORT ON UNIVERSITY DEVELOPMENT (contd)

THE OHIO STATE UNIVERSITY FOUNDATION (contd)

Establishment of Named Endowed Funds (contd)

Washington County 4-H Endowment Fund (contd)

The annual income shall be used to support the Washington County 4-H Youth Development Program. This support may include, but is not limited to: the funding of scholarships and awards for 4-H members, volunteer leaders, and friends of 4-H; sponsoring seminars and programs; and purchasing materials or services that will supplement 4-H programming or increase the visibility and public support for 4-H in Washington County. All expenditures from this fund shall be approved by the Washington County 4-H Council and the professional providing leadership to the Washington County 4-H program. Scholarships will be awarded in consultation with the University Committee on Student Financial Aid.

It is the desire of the donors that this fund should benefit the University in perpetuity. If the need for this fund should cease to exist or so diminish as to provide unused income, then another use shall be designated by the Foundation Board in consultation with the director for Ohio State University Extension and a committee representing the Washington County 4-H donors, in order to carry out the desire of the donors.

\$25,000.00

The Jacquelyn L. Wells Endowment Fund in Ovarian Cancer Research

The Jacquelyn L. Wells Endowment Fund in Ovarian Cancer Research at the Comprehensive Cancer Center – The Arthur G. James Cancer Hospital and Richard J. Solove Research Institute was established May 2, 2003, in accordance with the guidelines approved by the Board of Directors of The Ohio State University Foundation with a gift from William D. Wells in honor of the 50th birthday celebration of his beloved bride, Jacquelyn L. Wells.

All gifts to this fund are to be invested by the Foundation, under the rules and regulations adopted by the Foundation Board of Directors with the right to invest and reinvest as occasion dictates.

The annual income shall be used to support ovarian cancer research programs at the Comprehensive Cancer Center – The Arthur G. James Cancer Hospital and Richard J. Solove Research Institute at The Ohio State University as approved by the director of The Arthur G. James Cancer Hospital and Richard J. Solove Research Institute, the director of the Comprehensive Cancer Center, and the senior vice president for Health Sciences and dean of the College of Medicine and Public Health.

It is the desire of the donor that this fund should benefit the University in perpetuity. If the need for this fund should cease to exist or so diminish as to provide unused income, then another use shall be designated by the Board of Directors in consultation with the director of The Arthur G. James Cancer Hospital and Richard J. Solove Research Institute, the director of the Comprehensive Cancer Center, and the senior vice president of Health Sciences and dean of the College of Medicine and Public Health in order to carry out the desire of the donor.

\$25,000.00

The James F. Patterson Land-Grant University Lectureship Fund

The James F. Patterson Land-Grant University Lectureship Fund was established May 2, 2003, in accordance with the guidelines approved by the Board of Directors of The Ohio State University Foundation, with a gift from The Ohio State University Board of Trustees, the Nationwide Foundation, the Ohio Farm Bureau Federation, and friends.

REPORT ON UNIVERSITY DEVELOPMENT (contd)

THE OHIO STATE UNIVERSITY FOUNDATION (contd)

Establishment of Named Endowed Funds (contd)

The James F. Patterson Land-Grant University Lectureship Fund (contd)

All gifts are to be invested by the Foundation, under the rules and regulations adopted by the Foundation Board of Directors, with the right to invest and reinvest as occasion dictates.

The income shall be used to support an annual lectureship in James F. Patterson's name on the cause to which he is most committed, a vibrant University fulfilling its land-grant mission in an ever-changing world. It will bring to campus annually a prominent figure to speak to the range of challenges facing land-grant institutions in the 21st century and beyond.

It is the desire of the donors that this fund should benefit the University in perpetuity. If the need for this fund should cease to exist or so diminish as to provide unused income, then another use shall be designated by the Foundation Board in consultation with The Ohio State University Board of Trustees in order to carry out the desire of the donors.

Change in Description of Named Endowed Fund

The Paul A. and Betty L. Whittington Endowed Scholarship Fund

The Paul A. and Betty L. Whittington Endowed Scholarship Fund was established on February 7, 2003, in accordance with the guidelines approved by the Board of Directors of The Ohio State University Foundation with gifts from Paul A. and Betty L. Whittington, Sabina, Ohio. The description was revised on May 2, 2003.

All gifts are to be invested by the Foundation, under the rules and regulations adopted by the Foundation's Board of Directors, with the right to invest and reinvest as occasion dictates.

The annual income shall be used to support scholarships for undergraduate students with a 2.50 GPA or above enrolled in the College of Food, Agricultural, and Environmental Sciences. First preference is to student(s) who have graduated from East Clinton High School (Clinton County, Ohio). Preference is given to those with outstanding achievements who continue to lead and serve in the University community. If no student(s) are eligible from East Clinton High School then the second preference shall be given to student(s) from Clinton County, Ohio. Annual scholarship recipients shall be selected by the College Scholarship Committee in consultation with the University Committee on Student Financial Aid.

In any given year that the income is not fully expended, the unused portion should be reinvested in the principal.

It is the desire of the donors that this fund should benefit the University in perpetuity. If the need for this fund should cease to exist or so diminish as to provide unused income, then another use shall be designated by the Foundation Board, in consultation with the vice president for Agricultural Administration and University Outreach, and executive dean for Food, Agricultural, and Environmental Sciences or his successor, or an appropriate administrative officer or successor, in order to carry out the desire of the donors.

WAIVERS OF COMPETITIVE BIDDING REQUIREMENTS

Resolution No. 2003-121

JANUARY – MARCH 2003

Synopsis: Acceptance of the quarterly report on waivers of competitive bidding requirements is proposed.

WHEREAS the Purchasing Policy of The Ohio State University adopted by the Board of Trustees on September 7, 1984, and revised on February 7, 1992, July 8, 1994, November 7, 1997, and March 1, 2002 provides that the President and/or the Senior Vice President for Business and Finance, or for the Hospitals of the University and their related facilities, the Vice President for Health Services, may grant a waiver from competitive bidding in the event of an emergency, when a sufficient economic reason exists or when the goods or services can be purchased from only a single source, with a report on such waivers to be made quarterly to this Board; and

WHEREAS the Senior Vice President for Business and Finance has submitted a report on waivers of competitive bidding requirements granted for the period of January – March 2003; and

WHEREAS during the period covered, the Senior Vice President for Business and Finance, at the requests of the departments making the purchases and upon the recommendation of the Purchasing Department, granted 54 waivers of competitive bidding requirements for annual purchases totaling approximately \$9,095,900 as shown on the enclosed exhibit; and

WHEREAS during the period covered, the Vice President for Health Services, at the requests of the Hospitals of the University and their related facilities making purchases, granted 27 waivers of competitive bidding requirements for annual purchases totaling approximately \$4,411,000 as shown on the enclosed exhibit:

NOW THEREFORE

BE IT RESOLVED, That the report on waivers of competitive bidding requirements for the period of January – March 2003, is hereby accepted.

(See Appendix XLVI for background information, page 1083.)

CAPITAL PROJECTS

Resolution No. 2003-122

REQUEST FOR DESIGN AUTHORIZATION

GRADUATE AND PROFESSIONAL STUDENT HOUSING-RETAIL SPACE
JAMES CANCER HOSPITAL – 3 EAST AND 3 SOUTH
JAMES CANCER HOSPITAL LINEAR ACCELERATOR
LIMA CAMPUS – GALVIN HALL 4TH FLOOR RENOVATION
MARION CAMPUS - PARKING LOT #4
PUT-IN-BAY WATER LINE EXTENSION

REQUEST FOR CONSTRUCTION AUTHORIZATION

BIOLOGICAL SCIENCES – 5TH FLOOR BIOSAFETY LEVEL 3 FACILITY
CAMPUS GROUNDS – WEST CAMPUS PEDESTRIAN BRIDGE REPAIRS
DOAN HALL 11 – INFECTIOUS DISEASES
FOOTBALL PRACTICE FIELD #4 - TURF REPLACEMENT
JAMES CANCER HOSPITAL LINEAR ACCELERATOR
JOB ORDER CONTRACT 2003.B-CAMERA CENTER AND 650 ACKERMAN

CAPITAL PROJECTS (contd)

REQUEST FOR CONSTRUCTION AUTHORIZATION (contd)

OARDC – HAYDEN HALL RENOVATION
STUDENT FAMILY COMMUNITY CENTER AT BUCKEYE VILLAGE
WOODY HAYES ATHLETIC CENTER - TURF REPLACEMENT

Synopsis: Authorization to enter into design contracts for the Graduate and Professional Student Housing-Retail Space, James Cancer Hospital – 3 East and 3 South, James Cancer Hospital Linear Accelerator, Lima Campus – Galvin Hall 4th Floor Renovation, Marion Campus – Parking Lot #4, and Put-in-Bay Water Line Extension, and enter into construction contracts for Biological Sciences – 5th Floor BioSafety Level 3 Facility, Campus Grounds – West Campus Pedestrian Bridge Repairs, Doan Hall 11 – Infectious Diseases, Football Practice Field #4 – Turf Replacement, James Cancer Hospital Linear Accelerator, Job Order Contract 2003.B - Camera Center and 650 Ackerman, OARDC – Hayden Hall Renovation, Student Family Community Center at Buckeye Village, and Woody Hayes Athletic Center – Turf Replacement is requested.

WHEREAS the University desires to build first-floor retail space into the Graduate and Professional Student Housing facility; and

WHEREAS the preliminary project estimate is \$2,500,000, with funding to be provided by future University bond issues with debt service to be paid by Student Affairs; and

WHEREAS on the third floor east and the third floor south of the James Cancer Hospital, the University desires to upgrade patient rooms and renovate nurses stations and hallways; and

WHEREAS the preliminary project estimate is \$1,500,000 - \$2,500,000, with funding to be provided by the James Cancer Hospital and Solove Research Institute; and

WHEREAS at the James Cancer Hospital the University desires to renovate the patient procedure room and control area of the second floor linear accelerator room and install a new cooling system in this room; and

WHEREAS this project was originally included in the James Cancer Hospital Second Floor Renovation project and is being separated due to timing constraints; and

WHEREAS the preliminary project estimate is \$250,000, with funding provided by the James Cancer Hospital and Solove Research Institute; and

WHEREAS the University desires to renovate the third floor laboratory and classroom space at Galvin Hall in Lima to provide additional classroom facilities; and

WHEREAS the preliminary project estimate is \$367,657, with funding to be provided by House Bill 850; and

WHEREAS the University desires to construct 220 parking spaces on the Marion Campus displaced by construction of the Marion Campus Student Services Building; and

WHEREAS the preliminary project estimate is \$359,310, with funding to be provided by House Bill 675 (\$116,271), House Bill 640 (\$87,185.50), and Marion Campus (\$155,853.50); and

WHEREAS the University desires to extend water and sewer service to the Peach Point area of South Bass Island and Gibraltar Island and upgrade existing water and sewer pipes on Gibraltar Island; and

WHEREAS the preliminary project estimate is \$2,500,000, with funding to be provided by future University bond issues; and

CAPITAL PROJECTS (contd)

WHEREAS the University desires to renovate facilities in the Biological Sciences Building to meet the current standards for a BioSafety Level 3 containment facility; and

WHEREAS the preliminary project estimate is \$353,156, with funding to be provided by the College of Biological Sciences; and

WHEREAS on the West Campus, the University desires to replace the two pedestrian bridges across Carmack Road in front of Bevis Hall; and

WHEREAS the construction document project cost is \$260,000 with funding provided by House Bill 675; and

WHEREAS the University desires to renovate the 11th floor of Doan Hall to consolidate the infectious diseases office space; and

WHEREAS the construction document project cost is \$560,276, with funding provided by University Hospitals; and

WHEREAS the University desires to replace the turf on the football practice field #4 with an artificial surface; and

WHEREAS the construction document project cost is \$540,000, with funding to be provided by University bond proceeds with debt service to be paid by the Department of Athletics; and

WHEREAS the University desires to competitively bid a firm fixed price indefinite quantity contract known as Job Order Contracting 2003.B for the Camera Center and 650 Ackerman; and

WHEREAS separate bids for the pre-established guaranteed minimum value contract will be received for general \$50,000, electric \$10,000, HVAC \$10,000, and plumbing \$10,000 trades, and a maximum contract value for general \$3,000,000, electric \$250,000, HVAC \$250,000, and plumbing \$250,000 trades; and

WHEREAS bidders will submit price adjustment factors to be applied to established fixed unit prices specified in the unit price book, with the pre-established contract value for a term of one year, with options for three additional terms of one year each; and

WHEREAS the University will report a summary of projects performed under such Job Order Contract at the end of each calendar year; and

WHEREAS the University desires to upgrade existing laboratories, office space, and restrooms and install a new elevator and chiller system at Hayden Hall on the OARDC Wooster Campus; and

WHEREAS in June 2001, the Board of Trustees granted approval to enter into construction contracts for this project in the amount of \$850,000, and the anticipated project cost is now \$1,030,760 resulting from changes to the chiller and site utility locations during design coupled with increases arising from the bidding process, with funding provided by House Bill 675 (\$160,000), House Bill 790 (\$150,000), and OARDC (\$720,760); and

WHEREAS the University desires to construct a new community center at Buckeye Village; and

WHEREAS in July 2002, the Board of Trustees granted approval to enter into construction contracts for this project in the amount of \$5,400,000, and the construction document project cost is now \$5,676,310 due to project changes in chiller, electrical, and masonry requirements, with funding provided by future University bond proceeds with debt service to be paid by Student Affairs; and

CAPITAL PROJECTS (contd)

WHEREAS the University desires to replace the artificial turf on the indoor football field of the Woody Hayes Athletic Center; and

WHEREAS the construction document project cost is \$480,000, with funding to be provided by the Department of Athletics:

NOW THEREFORE

BE IT RESOLVED, That the President and/or Senior Vice President for Business and Finance be authorized to select qualified architectural/engineering firms as necessary for the Graduate and Professional Student Housing-Retail Space, James Cancer Hospital - 3 East and 3 South, James Cancer Hospital Linear Accelerator, Lima Campus - Galvin Hall 4th Floor Renovation, Marion Campus – Parking Lot #4, and Put-in-Bay Water Line Extension and that the fees for these services be negotiated between the firms selected and the University; and

BE IT FURTHER RESOLVED, That the President and/or Senior Vice President for Business and Finance be authorized to request construction bids for Biological Sciences - 5th Floor BioSafety Level 3 Facility, Campus Grounds - West Campus Pedestrian Bridge Repairs, Doan Hall 11 – Infectious Diseases, Football Practice Field #4 - Turf Replacement, James Cancer Hospital Linear Accelerator, Job Order Contract 2003.B - Camera Center and 650 Ackerman, OARDC - Hayden Hall Renovation, Student Family Community Center at Buckeye Village, and Woody Hayes Athletic Center - Turf Replacement projects are hereby accepted.

(See Appendix XLVII for background information and maps, page 1085.)

PURCHASE OF REAL PROPERTY

Resolution No. 2003-123

THOMPSON PROPERTIES

226 WEST NINTH AVENUE, COLUMBUS, OHIO
218-220 WEST NINTH AVENUE, COLUMBUS, OHIO
208-212 WEST NINTH AVENUE, COLUMBUS, OHIO
1549-1569 WORTHINGTON STREET, COLUMBUS, OHIO

Synopsis: Authorization to purchase property located at 226 West Ninth Avenue, 218-220 West Ninth Avenue, 208-212 West Ninth Avenue, and 1549-1569 Worthington Street, all in Columbus, Ohio, is requested.

WHEREAS the Board of Trustees of The Ohio State University is presented with an opportunity to purchase the improved real property located at 226 West Ninth Avenue, 218-220 West Ninth Avenue, 208-212 West Ninth Avenue, and 1549-1569 Worthington Street, all in Columbus, Ohio, owned by Thomas D. Thompson and Charles R. Dersom, Trustees, at a price of \$845,000.00; and

WHEREAS the appropriate University offices have determined that the purchase of these properties is in the best interest of the University; and

WHEREAS funding for the acquisition and use of these properties will be provided by Student Affairs:

NOW THEREFORE

BE IT RESOLVED, That the President and/or Senior Vice President for Business and Finance be authorized, in the name of the State of Ohio for the use of The Ohio State University, to purchase from Thomas D. Thompson and Charles R. Dersom, Trustees, the improved real property located

PURCHASE OF REAL PROPERTY (contd)

in Columbus, Ohio, at 226 West Ninth Avenue, 218-220 West Ninth Avenue, 208-212 West Ninth Avenue, and 1549-1569 Worthington Street, at a purchase price of \$845,000.00, plus fees and closing costs, upon such terms and conditions as are deemed to be in the best interest of the University, subject to the University receiving the necessary approvals from the Ohio Board of Regents and the State Controlling Board.

(See Appendix XLVIII for background information and map, page 1113.)

2003-2004 UNDERGRADUATE TUITION

Resolution No. 2003-124

Synopsis: Instructional, general and nonresident fees for undergraduate students enrolled at all campuses for Fiscal Year 2003-04 are proposed effective Summer Quarter 2003.

WHEREAS the Board of Trustees of The Ohio State University supports the University's continued implementation of the Academic Plan and its initiatives to meet the needs of Ohio State students; and

WHEREAS in recognition of the concerns raised about the economic difficulty many Ohio families now face, the Board supports the continued phase in of additional fees for new entering students at the Columbus Campus; and

WHEREAS the tuition rates to be adopted are specifically based on the level of State support provided in the Governor's Executive Budget and could be modified if State support for higher education is either increased or decreased; and

WHEREAS consultations continue to take place with regard to professional college and graduate fees and those fees will be determined as a part of the regular 2003-04 budget process:

NOW THEREFORE

BE IT RESOLVED, That Instructional and General Fees for all undergraduates enrolled at the Columbus Campus be increased by 9.0% (an additional \$156 per quarter for full time students enrolled prior to Summer Quarter 2002 (tier 1) and \$170 per quarter for full time students enrolled after Spring Quarter 2002 and prior to Summer Quarter 2003 (tier 2)); and

BE IT FURTHER RESOLVED, That Instructional and General Fees for all new undergraduate full time students enrolled at the Columbus Campus beginning Summer Quarter 2003 (tier 3) be increased by an additional \$100 per quarter above the tier 2 fees beginning Summer Quarter 2003; and

BE IT FURTHER RESOLVED, That the Instructional and General Fees be increased 6.0% for all undergraduate students at the Agricultural Technical Institute (\$90 per quarter for a full time student) and the regional campuses (\$91 per quarter for a full time student), and that the Access Challenge offset at ATI and all regional campuses not change for Summer Quarter 2003 but is subject to change for the academic year starting Autumn Quarter 2003 pending the level of funding provided in the State budget; and

BE IT FURTHER RESOLVED, That the undergraduate nonresident surcharge at Columbus and regional campuses be increased by 6.0% (\$188 per quarter for a full time student) beginning Summer Quarter 2003.

(See Appendix XLIX for background information, page 1115.)

FISCAL YEAR 2002-03 THIRD QUARTER BUDGET REPORT

Resolution No. 2003-125

Synopsis: The third quarter budget report for fiscal year 2002-03 is submitted for adoption.

WHEREAS the State of Ohio has cut FY 2002-03 funding to State-assisted institutions of higher education, resulting in a \$7.7 million (2.5%) reduction in the Columbus Campus State Share of Instruction and an \$11.2 million overall reduction in all line items for all campuses; and

WHEREAS the University's enrollments for summer through spring quarters are now known, allowing for a more accurate picture of the University's student fee revenue; and

WHEREAS other revenues such as indirect cost recoveries on sponsored programs have been projected higher than originally budgeted; and

WHEREAS appropriate planning and consultation within the University has been accomplished and the President now recommends approval of the third quarter budget report:

NOW THEREFORE

BE IT RESOLVED, That the appropriate resources and expenditure budgets be adjusted to reflect these changes as of the third quarter as described in the attached materials.

(See Appendix L for background information, page 1123.)

Upon motion of Mr. McFerson, seconded by Mrs. Davidson, the Board of Trustees adopted the foregoing resolutions by unanimous roll call vote, cast by Messrs. Patterson, Sofia, Slane, McFerson, Borrer, and Judge Duncan, Meses. Longaberger, Hendricks, and Davidson.

APPOINTMENT AND REAPPOINTMENT OF INVESTMENT MANAGERS

Resolution No. 2003-126

Synopsis: Approval of the appointment and reappointment of investment managers is proposed.

WHEREAS it is the policy of The Ohio State University to utilize the service of external investment managers to assist in the management of the University's Endowment Fund; and

WHEREAS the Investments Committee of the Board of Trustees periodically reviews the results obtained by the external investment managers and the amount of funds assigned to each of them; and

WHEREAS it is prudent investment policy to adjust the mix and amounts of money assigned to external Investment Managers as economic conditions and performance change; and

WHEREAS the number of external investment managers and the amount of funds assigned to them shall be determined by the Board of Trustees:

NOW THEREFORE

BE IT RESOLVED, That upon the recommendation of the Investments Committee of the Board of Trustees, the following named external investment managers and the Office of the Treasurer shall be approved to manage Endowment Funds as follows:

APPOINTMENT AND REAPPOINTMENT OF INVESTMENT MANAGERS (contd)

<u>Large Cap Equity Managers</u>	<u>Market Value/ Commitment As of 3/31/03</u>	<u>Changes</u>	<u>Revised Allocation</u>
ABN AMRO	\$29,718,443	\$0	\$29,718,443
Barclays S&P 500	\$158,208,119	(\$50,000,000)	\$108,208,119
Barclays Value Index	\$19,516,401	(\$19,516,401)	\$0
Fifth Third Bank Investment Advisors	\$0	\$25,000,000	\$25,000,000
Huntington Trust	\$0	\$25,000,000	\$25,000,000
Nicholas Applegate Mid Cap	\$64,123,978	\$0	\$64,123,978
University Students	\$13,424,621	\$0	\$13,424,621
<u>Small Cap Equity Managers</u>			
Barclays Value Index	\$0	\$19,516,401	\$19,516,401
Barclays Extended	\$116,679,755	\$0	\$116,679,755
Meeder Financial	\$63,371,240	\$0	\$63,371,240
Nicholas Applegate Small Cap	\$20,278,231	\$0	\$20,278,231
<u>International Equity Managers</u>			
Barclays International	\$31,099,019	\$0	\$31,099,019
Invesco Global Asset	\$15,559,221	\$0	\$15,559,221
Sit International	\$9,515,235	\$0	\$9,515,235
<u>Fixed Income Managers</u>			
Banc One	\$27,311,529	\$0	\$27,311,529
Commonfund High Yield Bonds	\$14,786,945	\$0	\$14,786,945
Cypress Asset Management	\$25,846,524	\$0	\$25,846,524
Hughes Capital Management	\$16,234,368	\$0	\$16,234,368
Huntington Trust	\$33,204,046	\$0	\$33,204,046
MDL Capital Management	\$80,935,319	\$0	\$80,935,319
<u>Alternative Managers</u>			
CID Seed Fund	\$1,000,000	\$0	\$1,000,000
Commonfund Hedged Investors	\$15,000,000	\$0	\$15,000,000

APPOINTMENT AND REAPPOINTMENT OF INVESTMENT MANAGERS (contd)

<u>Alternative Managers (contd)</u>	<u>Market Value/ Commitment As of 3/31/03</u>	<u>Changes</u>	<u>Revised Allocation</u>
Commonfund New Leaders	\$10,000,000	\$0	\$10,000,000
Commonfund Capital Partners	\$7,067,000	\$0	\$7,067,000
EDF Ventures Seed Fund	\$1,000,000	\$0	\$1,000,000
Mesirow Partnership Fund I	\$10,000,000	\$0	\$10,000,000
Ramius Fund	\$15,000,000	\$0	\$15,000,000
Reservoir Venture Partners (formerly Battelle Technology Fund)	\$2,625,000	\$0	\$2,625,000

Upon motion of Mr. McFerson, seconded by Mr. Sofia, the Board of Trustees adopted the foregoing resolution with seven affirmative votes, cast by Messrs. Sofia, Slane, McFerson, and Judge Duncan, Mses. Longaberger, Hendricks, and Davidson, and two abstentions cast by Messrs. Patterson and Borrer.

--0--

PURCHASE OF REAL PROPERTY

Resolution No. 2003-127

650 ACKERMAN ROAD, COLUMBUS, OHIO

Synopsis: Authorization to purchase the improved real property located at 650 Ackerman Road, Columbus, Ohio, owned by The Ohio State University Foundation, is requested.

WHEREAS the Board of Trustees of The Ohio State University is presented with an opportunity to purchase approximately 26.4 acres of improved real property located at 650 Ackerman Road, Columbus, Ohio, owned by The Ohio State University Foundation; for a purchase price of approximately \$16,328,000; and

WHEREAS this property is strategically located adjacent to the Columbus Campus and its acquisition will provide needed space for research and other mixed uses that support the Academic Plan, and the appropriate University offices have determined that the purchase of this property is in the best interest of the University; and

WHEREAS funding for this transaction will be provided by University bond proceeds, with rental income being used to pay debt service and cover operating expenses:

NOW THEREFORE

BE IT RESOLVED, That the President and/or Senior Vice President for Business and Finance be authorized, in the name of the State of Ohio for the use of The Ohio State University, to purchase from The Ohio State University Foundation the property located at 650 Ackerman Road, Columbus, Ohio, for the purchase price of approximately \$16,328,000, plus closing costs and fees, upon such terms and conditions as are deemed to be in the best interest of the University, subject to the University receiving the necessary approvals from the Ohio Board of Regents and the State Controlling Board.

PURCHASE OF REAL PROPERTY (contd)

Upon motion of Ms. Hendricks, seconded by Mr. Borrer, the Board of Trustees adopted the foregoing resolution with eight affirmative votes, cast by Messrs. Patterson, Sofia, McFerson, Borrer, and Judge Duncan, Meses. Longaberger, Hendricks, and Davidson, and one abstention cast by Mr. Slane.

(See Appendix LI for background information and map, page 1129.)

--0--

FAREWELL TO JAMES F. PATTERSON

President Karen A. Holbrook:

Before Mr. Patterson makes his concluding remarks, I have both the honor and privilege of expressing the gratitude on the part of the University for the outstanding service that Jim has provided to this Board and University, not just during his nine years of tenure on the Board, but during all of the time he has been at Ohio State. From the time he entered as an undergraduate student, he remained committed from that time thereon.

Last night, we had an opportunity to bring together as Nancy said, "115 of our dearest friends" -- and they truly were as you could tell by the audience -- to honor both Jim and Nancy Patterson for all that they've done. Included among that group were four generations of Pattersons, including Johnny, the new grandson, who started to sing when his grandfather started to talk. So it was delightful to have him with us last evening.

The kinds of words that were said last night I can't begin to repeat here. Every comment that was made about both Jim and Nancy were heartfelt, sincere, warm, and very meaningful. Everyone repeated the same kind of message -- "Jim is dedicated," "Jim is loyal," "Jim has integrity," "he is committed," and "he loves this University." The kinds of things he's done with both vision and care and compassion for people and this University are very hard to duplicate anywhere.

Everyone is going to deeply miss you as a member of the Board of Trustees. But we won't miss you because you're not going to be here once a year, we're going to keep finding as many excuses as we possibly can to bring you back to this campus. We truly can't do without your input, advice, support, and leadership in so many different domains. Thank you, from the bottom of our hearts, every one of us, for all the wonderful things you've done. You've meant a great deal to everyone. You know how much you've meant to me as a new person at this University. We thank you, very deeply.

We have a small token of our appreciation, which is a lovely gavel. Nancy, I have been wondering all morning exactly who Jim is going to keep in line with this gavel? It is a small token to recognize all that you've done and we know that you will continue to do for this great University. Your friendship is definitely "affirmed," to quote *Carmen Ohio*. Thank you so much.

Mr. Patterson:

Since I won't be chairing the Board, we'll have to give this to Nancy and she can beat on me. As most of you know, she already does! Like we said last night, when you ask for one of us, you get two of us, like it or not.

Just a couple of thoughts. As this May meeting of the Board of Trustees closes, so does my tenure as a Trustee at Ohio State. Previous Board member Alex

FAREWELL TO JAMES F. PATTERSON (contd)

Mr. Patterson: (contd)

Shumate told me when I became a member of the Board nine years ago that it would go by in the blink of an eye and he was so correct. To the rest of you, it will happen quickly. Doug, as the new member, it's going to go like this [snap of his fingers].

It's hard to imagine that any other nine-year period could have such a dramatic effect on the University as the last nine years have been. I've been truly fortunate to have a ringside seat as some of these significant events have unfolded. The University is dynamic and ever changing as it fulfills its role and mission as one of the world's eminent public land-grant universities of higher learning. There are so many initiatives and events that stand out in my mind that it is hard to point out just a few. But some were so significant that they bear mentioning.

First is the adoption of the Academic Plan. This document is the foundation, which brings focus to our mission as we strive to become an even greater university. To have brought all of the different constituencies of the University together to adopt such a defining document, as many of you can attest, is an accomplishment in and of itself.

The Diversity Plan is not idle chatter for Ohio State. It must be a primary goal. No great university can maintain its greatness if all people are not a part of its culture. When we speak of diversity, it is about race, gender, nationalities, preferences, and backgrounds. It is the need to recognize the difference between all of us and to accept those differences so that we are all regarded as equal. Understanding and accepting others is basic to our society. There are unmet challenges as we go forward, but I am confident that these will be addressed in both the near and the short-term.

With Campus Partners we're a long way from where we need to be, but we have made strides. Bureaucracy is frustrating. The area east of High Street was a disgrace to the University. My concern has always been that the area needed to be developed for the students, which includes some libation establishments. Not to attract others to come, but to benefit those we serve. It will happen and we'll see marked changes in the next couple of years.

Buildings from the Longaberger Alumni House -- this magnificent facility that we meet in, thanks to Tami and her family -- to the Schott, to the finest football stadium in the country to the baseball field. From the Knowlton architecture building to the Blackwell Inn, to the new physics building, to the Fisher College of Business complex; how that intersection has changed. From The James Hospital to the Heart Hospital, and -- my personal favorite -- a new Ohio 4H Center. Just taking into account projects over \$5 million, in the nine years that I've been a Trustee, the University has completed, or has under development, over \$1.9 billion in capital projects. Amazing! A great university must provide the finest physical facilities to attract the finest faculty, staff, and students.

In 2000 we completed a fundraising effort that was one of the most outstanding ever held by any university in the country. From an original goal of \$850 million, we raised \$1.23 billion. "Affirm Thy Friendship" became synonymous with our strides to greatness. So many generous people and involved workers all contributed mightily to make this effort such a huge success.

There are so many initiatives that I could go on and on. The adoption of selective admissions year round while assuring access and a single practice plan

FAREWELL TO JAMES F. PATTERSON (contd)

Mr. Patterson: (contd)

for the Medical Center. These two plans have been talked about for years. The growth of our regional campuses -- these are all efforts that we can take tremendous pride in.

I have had the opportunity to work with five presidents: Gordon Gee was president when I started, followed by Dick Sisson as interim president. Then I had the opportunity to serve on the search committee when we selected Brit Kirwan, and through his tenure, and then Ed Jennings as the second interim. I could go on and on how much I have admired all of these gentlemen. They have indelibly left their mark on the history of Ohio State.

This past year we began a search to find the next great president. Working with an outstanding search committee who all became personal friends, we found that person. I am so proud of that effort and the selection of Karen Holbrook that I beam with pride just as a new grandfather would, which many of you know I am. Karen is the perfect person to make this great University even greater. I could not be more pleased in her leadership and, I know, that the future could not be in better hands.

I want to leave you with only one admonition and that is that I entrust to all of you the need to ensure for now and always that Ohio State strives for excellence to be a great public land-grant university. The term "public land-grant university" is not just a reference to history; it is as viable and as needed a concept now as it always has been.

Using our friends to the north, I have often said that we have the mission of Michigan State and the goal of excellence of the University of Michigan. Our path is harder and steeper, but I submit to you that we are better than either in our quest for this lofty position. We are a university where learning, discovery, and engagement are equally important. We are a university where accessibility, diversity, and affordability all converge with our mission to ensure academic excellence. Don't any of us ever let this University lose sight of this responsibility we all share.

None of these accomplishments that I've been referring to have been realized without the finest group of people that I have come to know. I have built so many treasured and lasting friendships. To my fellow Trustees, both past and present, to the outstanding Student Trustees that I've had the good fortune to work with, to the faculty, who continue to impress me so much, to those in the administration who are so talented, to the staff who are invaluable to our success, to the alumni and many friends of the University who give tirelessly of their time, and most importantly to all of the outstanding students, for which we all exist, it has truly been my privilege to know and be your friend. Thank you.

I'd now like to turn the gavel over to a gentleman who has been a dear friend for eight of my nine years -- he came on the Board a year after me -- Zuheir Sofia. Zuheir's interest and dedication to this University will serve him well this coming year. It has truly been one of Nancy and my best experiences to get to know Susan and Zuheir over these years and to have had so many experiences with them. He will prove to be a great chairman for this University.

It's my privilege to turn the gavel over to Zuheir.

FAREWELL TO JAMES F. PATTERSON (contd)

Mr. Sofia:

Thank you, Mr. Chairman. Talking about how time flies, I reminded Jim last night that Maurice Clarett was in the fifth grade when he was named to the Board. We are delighted to have had Jim's leadership. Last night we had a wonderful event for him and we truly thank him for his leadership, splendid service, and his warm manner. He truly has tremendous affection and commitment to The Ohio State University.

I'd like to take the opportunity to thank the Board of Trustees Office: Dr. David Frantz, Maureen Sharkey, Lucy Gandert, and Suzanne Blake. They are probably the most efficient unit at the University. They work really hard and we ought to give them a hand for all of the work they do for us.

It is certainly an honor to serve as chairman of the Board of Trustees and it is, indeed, even more of an honor to serve with such a distinguished group of Trustees. They truly are dedicated and I can assure you we are all committed to achieving the Academic Plan with Dr. Holbrook's leadership.

As we always say, Ohio State is a great institution, but with all of your help and support it is on its way of becoming a premier university in our nation. I hope we all do our part in achieving that goal.

--0--

Thereupon the Board adjourned to meet Friday, May 30, 2003, at The Ohio State University Longaberger Alumni House, Columbus, Ohio.

Attest:

David O. Frantz
Secretary

James F. Patterson
Chairman

**Waivers of Competitive Bidding Requirements
January-March 2003**

(APPENDIX XLVI)

<u>Category</u>	<u>Total</u>	<u>Sole Source</u>	<u>Emergency</u>	<u>Sufficient Economic Reason</u>
Hospitals - Professional Health Care Services	\$518,000	\$440,000	\$0	\$78,000
Hospitals - Equipment and Services	\$3,892,922	\$3,135,124	\$91,878	\$665,920
Merchandise For Resale	\$5,191,618	\$691,618	\$0	\$4,500,000
Instructional and Research Equipment and Services	\$1,004,195	\$456,637	\$0	\$547,558
Administrative Support Equipment and Services	\$2,799,077	\$743,175	\$533,828	\$1,522,074
Conference Facilities	\$100,979	\$40,979	\$0	\$60,000
TOTAL	\$13,506,791	\$5,507,533	\$625,706	\$7,373,552

(APPENDIX XLVII)
AUTHORIZATION FOR CAPITAL PROJECTS

Project	Approved Amount	Funding Source	Requested Action
Graduate and Professional Student Housing - Retail Space	\$2.500 M	Dept:	\$2.500 M Enter into design contracts
James Cancer Hospital - 3 East and 3 South	\$1.500 M	Dept:	\$1.500 M Enter into design contracts
James Linear Accelerator	\$0.250 M	Dept:	\$0.250 M Enter into design contracts
Lima Campus-Galvin Hall 4th Floor Renovation	\$0.368 M	State:	\$0.368 M Enter into design contracts
Marion Campus-Parking Lot #4	\$0.359 M	State: Dept:	\$0.203 M Enter into design contracts \$0.156 M
Put-in-Bay Water Line Extension	\$2.500 M	Dept:	\$2.500 M Enter into design contracts
<hr/>			
Biological Science-5th Floor Biosafety Level 3 Facility	\$0.353 M	Dept:	\$0.353 M Enter into construction contract
Campus Grounds-West Campus Pedestrian Bridge Repair	\$0.260 M	State:	\$0.260 M Enter into construction contract
Doan Hall 11-Infectious Diseases	\$0.411 M	Dept:	\$0.411 M Enter into construction contract
Football Practice Field #4 Turf Replacement	\$0.540 M	Dept:	\$0.540 M Enter into construction contract
James Linear Accelerator	see above	Dept:	see above Enter into construction contract
Job Order Contract 2003.B Camera Center and 650 Ackerman	\$3.750 M	Dept:	\$3.750 M Enter into construction contract
OARDC-Hayden Hall Renovation	\$1.031 M	State: Dept:	\$0.310 M Enter into construction contract \$0.721 M
Student Family Community Center at Buckeye Village	\$5.676 M	Dept:	\$5.676 M Enter into construction contract
Woody Hayes Athletic Center Turf Replacement	\$0.480 M	Dept:	\$0.480 M Enter into construction contract
Total By Source:		Dept: State:	\$ 1.141 M \$ 18.837 M
Total	\$19.978 M		\$19.978 M



Graduate and Professional Student Housing - Retail Space

315-1996-976-2

Requesting Agency(s): STUDENT AFFAIRS, OFFICE OF

Location(s): Site - See Comments.

Gross Sq. Ft.0 Age:

Description: Buildout of first floor retail space. Facility will include coffee bar, hot food servery, cold deli, and grab and go selections. Space is provided for patrons to eat in or carry out.

Project Team:

Facility Planner: Is Unassigned

Project Captain: Marjory Spangler
(spangler.40@osu.edu)

Project Assistant: Curt Handschug
(handschug.1@osu.edu)

Field Coordinator: Is Unassigned

Project Information:

Site - Neil between 9th and 10th Avenue and along 10th Avenue between Neil and Worthington

Preliminary Project Budget \$2.5M

Source of Funds:	Original	Revised	Uses of Funds:	As Designed	As Bid	Completion
Future Univ. Bond Issues	\$2,500,000.00	\$2,500,000.00				
Total:	\$2,500,000.00	\$2,500,000.00	Total:			

Schedule:	Projected	Revised	Actual
Planning			
Arch/Engr Approved by B/T	05/02/2003		
Bidding Approved B/T	06/06/2003		
Bidding			
Bid Opening	07/08/2003		
Construction			
Award of Contracts	08/04/2003		
Construction Start	08/04/2003		
Completion	12/19/2003		

Graduate and Professional Student Housing - Retail Space

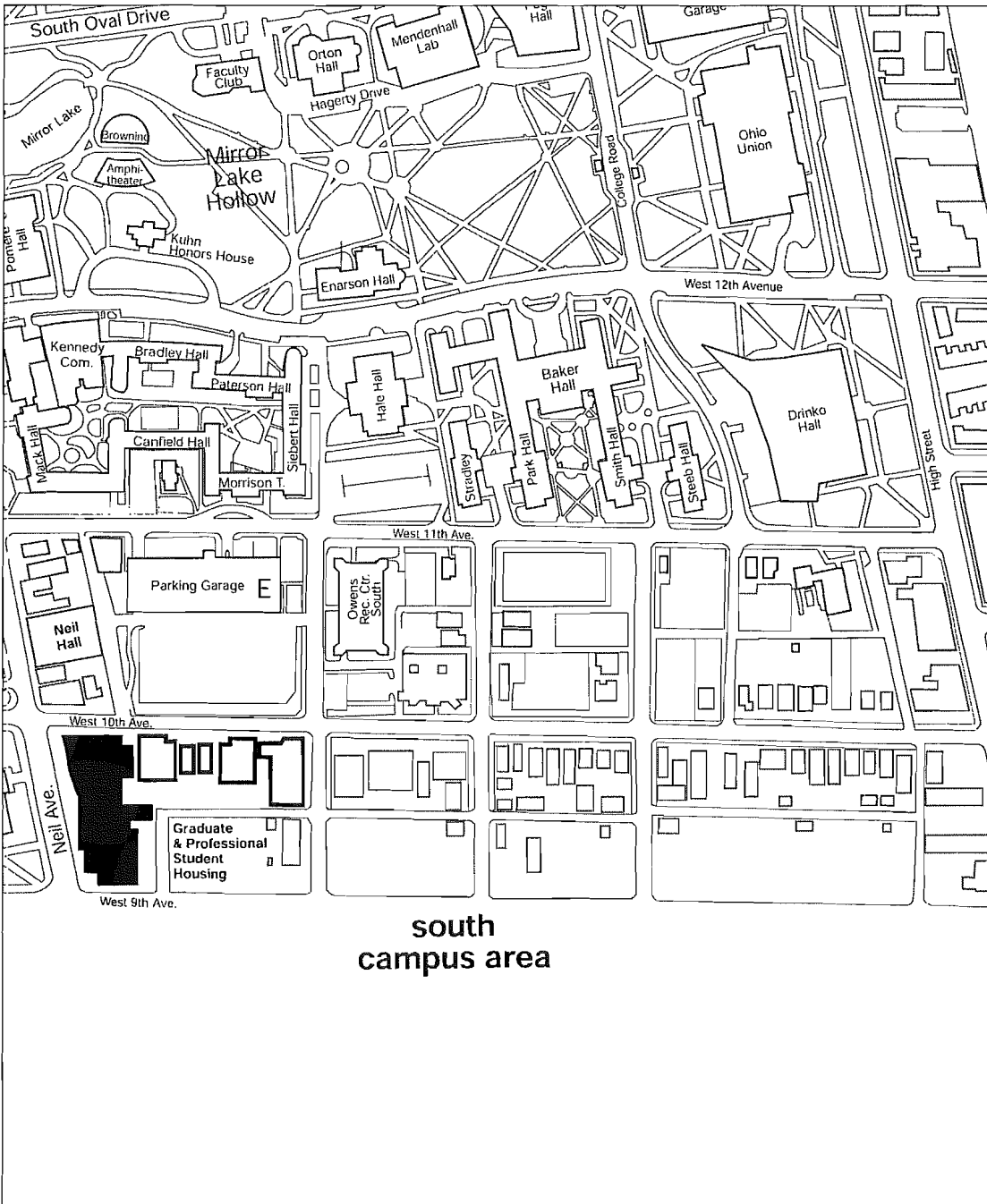

**south
campus area**

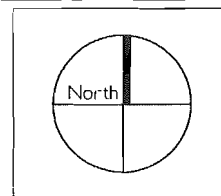

Office of Business and Finance
Office of Facilities Planning and Development

April 16, 2003



James Cancer Hospital - 3 East and 3 South

315-2003-939

Requesting Agency(s): CANCER HOSPITAL & RESEARCH INSTITUTE

Location(s): COMPREHENSIVE CANCER CENTER, OSU

Gross Sq. Ft.30,907 Age: 1980

Description: Upgrade patient rooms and renovate nurses station and hallways.

Project Team:

Facility Planner: Is Unassigned

Project Captain: Richard Van Deusen
(van-deusen.2@osu.edu)

Project Assistant: Curt Handschug
(handschug.1@osu.edu)

Field Coordinator: Is Unassigned

Project Information:

Preliminary project budget \$1.5M - \$2.5M. Final budget will be determined as a part of the design process. Replaced 50700-R034553 & 50700-R034554

Source of Funds:	Original	Revised	Uses of Funds:	As Designed	As Bid	Completion
Auxiliaries-James Cancer Hospital	\$1,500,000.00	\$1,500,000.00				
Total:	\$1,500,000.00	\$1,500,000.00	Total:			

Schedule:	Projected	Revised	Actual
Planning Arch/Engr Approved by B/T	05/02/2003		

James Cancer Hospital - 3 East and 3 South

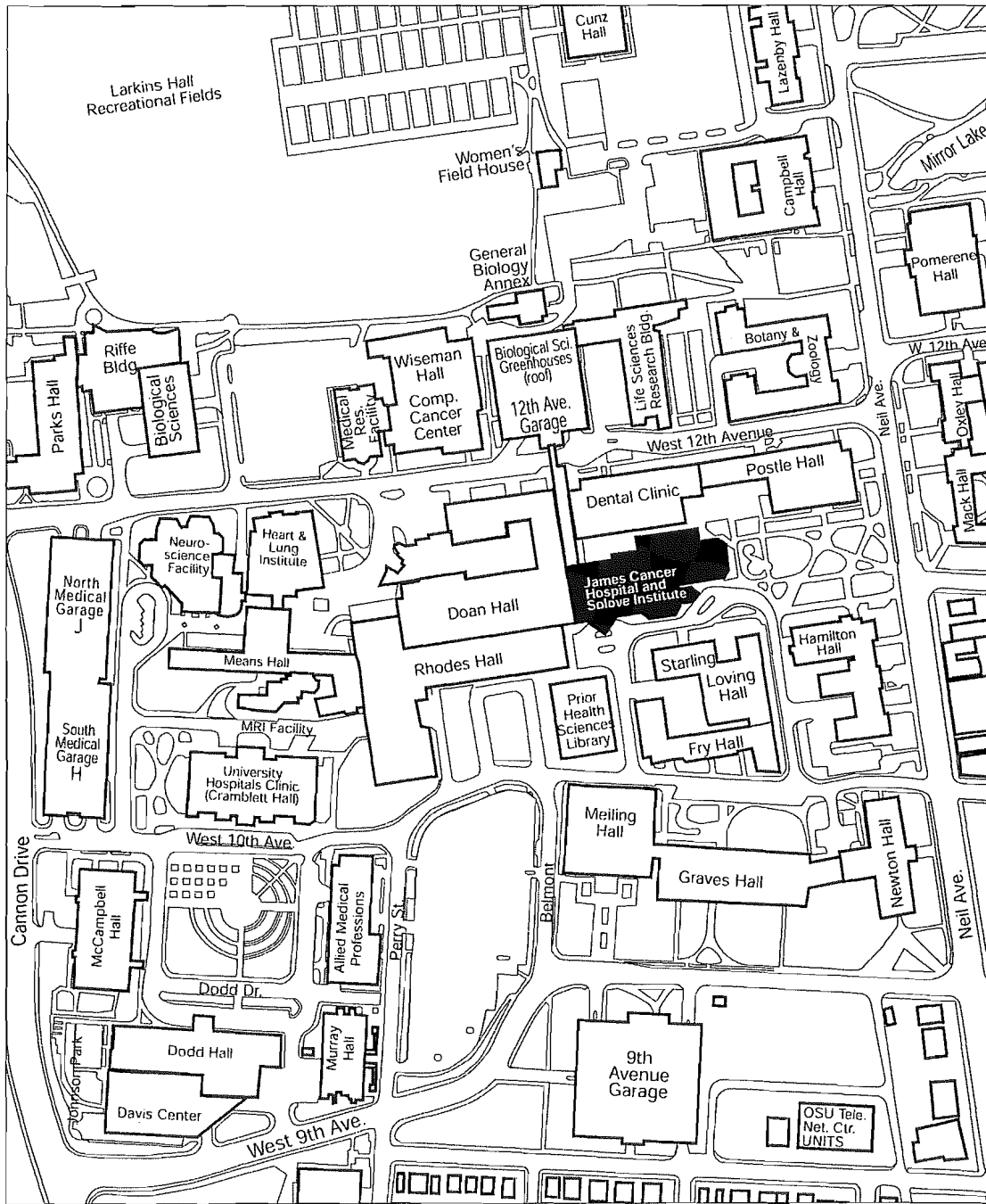

Office of Business and Finance
Office of Facilities Planning and Development

April 09, 2003



Requesting Agency(s): CANCER HOSPITAL & RESEARCH INSTITUTE

Location(s): JAMES CANCER HOSP & SOLOVE RES INST

Gross Sq. Ft. 265,423 Age: 1990

Description: Renovate the patient procedure room and control area along with the installation of a new cooling system.

Project Team:

Facility Planner: Is Unassigned

Project Captain: Richard Van Deusen
(van-deusen.2@osu.edu)

Project Assistant: Patricia Berger
(berger.58@osu.edu)

Field Coordinator: Is Unassigned

Project Information:

Preliminary project budget \$250,000

Source of Funds:	Original	Revised	Uses of Funds:	As Designed	As Bid	Completion
Auxiliaries-James Cancer Hospital	\$250,000.00	\$250,000.00				
Total:	\$250,000.00	\$250,000.00	Total:			

Schedule:	Projected	Revised	Actual
Planning			
Arch/Engr Approved by B/T	05/02/2003		
Bidding Approved B/T	05/02/2003		

James Linear Accelerator

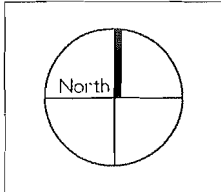
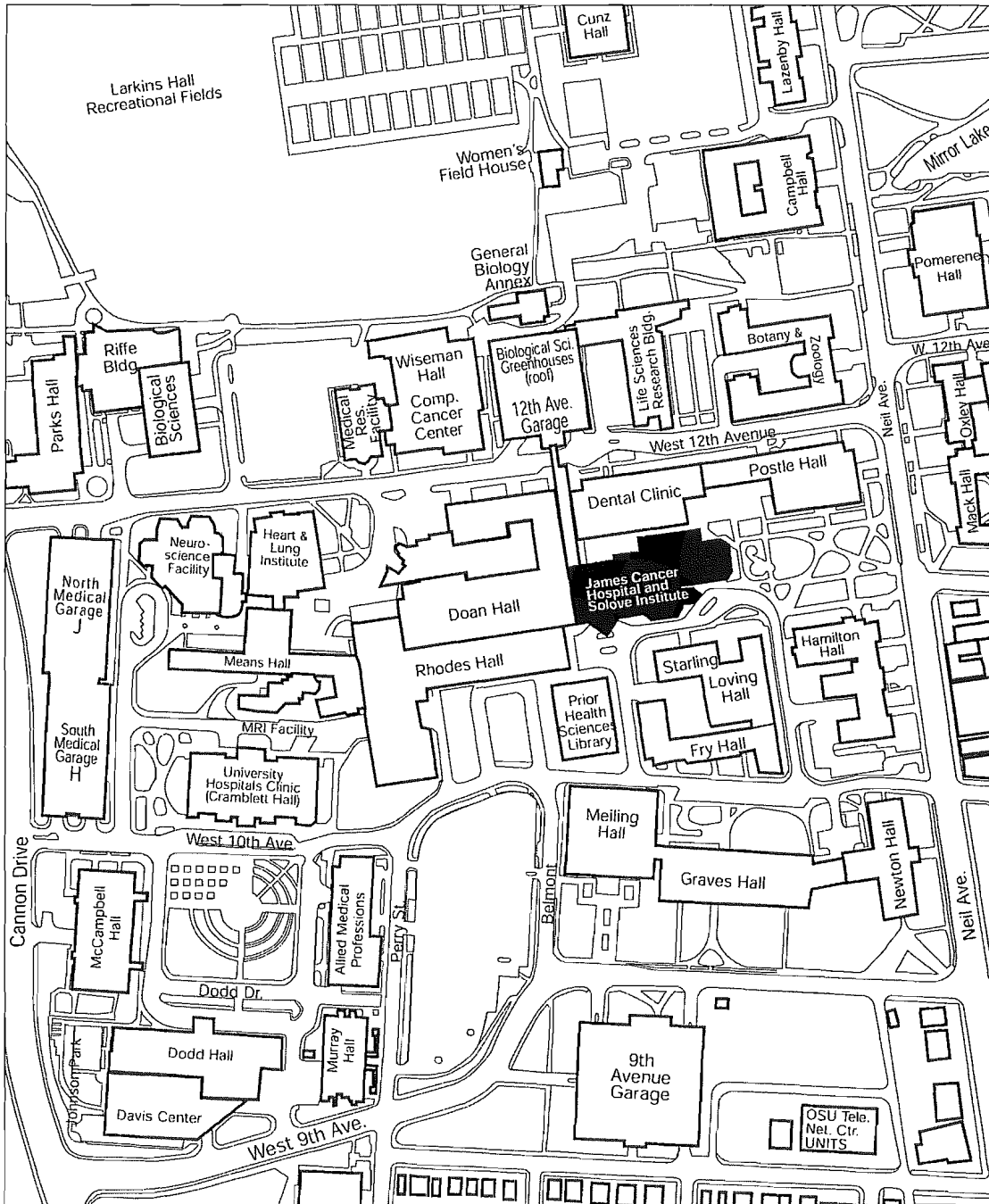

Office of Business and Finance
Office of Facilities Planning and Development

April 09, 2003



Lima Campus - Galvin Hall 4th Floor Renovation

315-2003-940

Requesting Agency(s): LIMA CAMPUS

Location(s): GALVIN HALL

Gross Sq. Ft.81,719 Age: 1966

Description: Renovation of approximately 5,000 square feet of administrative and instructional space of the north portion of Galvin Hall on the Lima Campus.

Project Team:

Facility Planner: Is Unassigned

Project Captain: Christine Lawson
(lawson.132@osu.edu)

Project Assistant: Leeanne Chandler
(chandler.63@osu.edu)

Field Coordinator: Is Unassigned

Project Information:

Preliminary project budget \$367,657

Source of Funds:	Original	Revised	Uses of Funds:	As Designed	As Bid	Completion
HB850 Line Item	\$367,656.80	\$367,656.80				
Appropriation			Total:			
Total:	\$367,656.80	\$367,656.80				

Schedule:	Projected	Revised	Actual
Planning			
Arch/Engr Approved by B/T	05/02/2003		

Lima Campus - Galvin Hall Fourth Floor Renovation

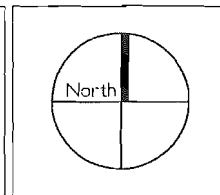
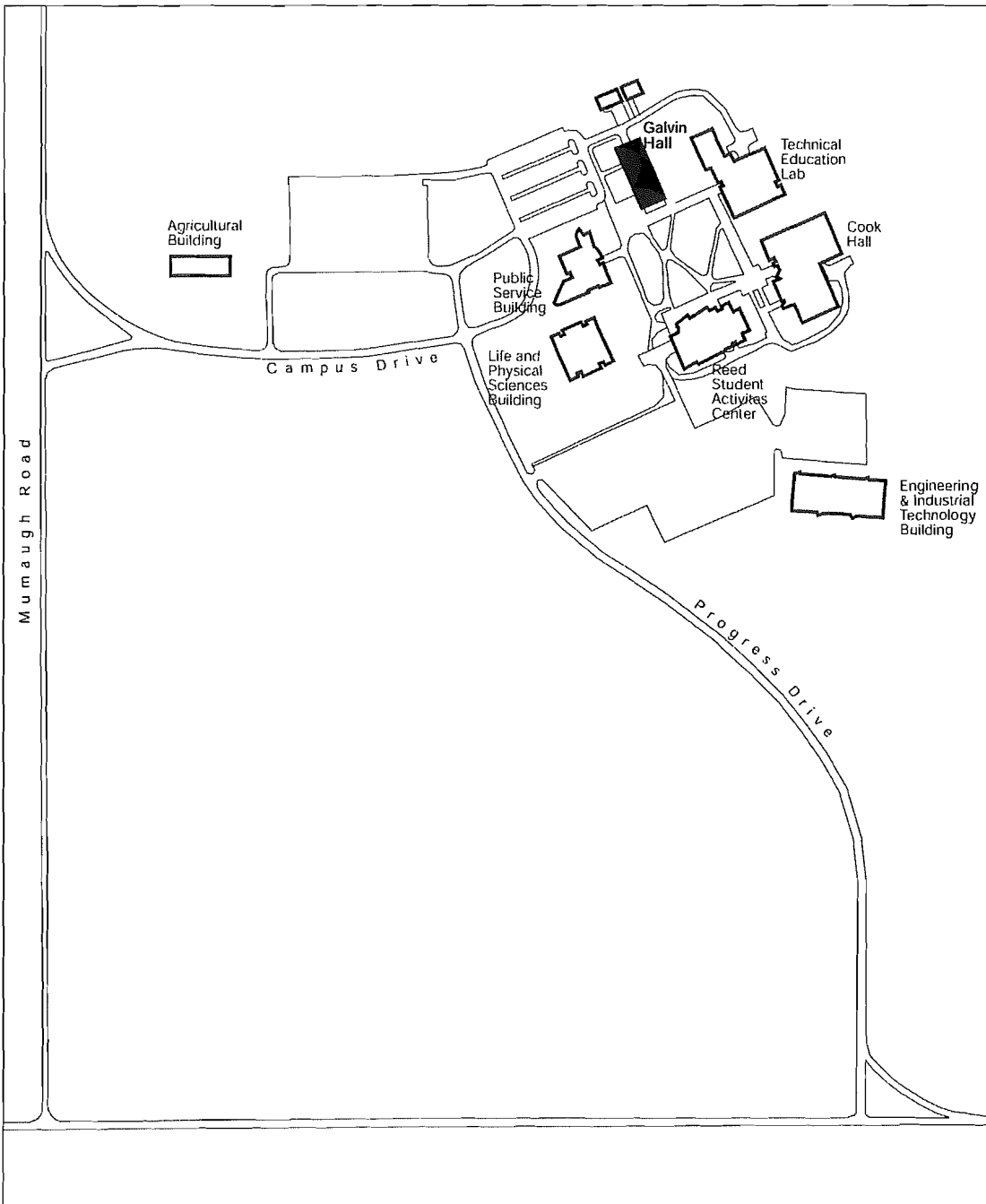

Office of Business and Finance
Office of Facilities Planning and Development

April 10, 2003



Marion Campus - Parking Lot #4

315-2003-941

Requesting Agency(s): MARION CAMPUS

Location(s): Site - See Comments.

Gross Sq. Ft.0 Age:

Description: 220 parking spaces in an asphalt paved lot with safety lighting as required

Project Team:

Facility Planner: Is Unassigned
 Project Captain: Marty Bricker
 Project Assistant: Faye Bodyke
 (bodyke.3@osu.edu)
 Field Coordinator: Is Unassigned

Project Information:

Preliminary project budget \$359,310
 Site is east and southeast of parking lot #3

Source of Funds:	Original	Revised	Uses of Funds:	As Designed	As Bid	Completion
General Funds-Marion	\$155,853.50	\$155,853.50				
HB640 Marion Basic	\$87,185.50	\$87,185.50	Total:			
Renovations						
HB675 Regional Basic	\$116,271.00	\$116,271.00				
Renovation						
Total:	\$359,310.00	\$359,310.00				

Schedule:	Projected	Revised	Actual
Planning			
Arch/Engr Approved by B/T	05/02/2003		
Design			
Arch/Engr Contract	06/01/2003		
Construction Document Approval	06/30/2003		
Bidding			
Bid Opening	09/01/2003		
Construction			
Award of Contracts	09/15/2003		
Construction Start	09/15/2003		
Completion	11/15/2003		

Marion Campus - Parking Lot #4

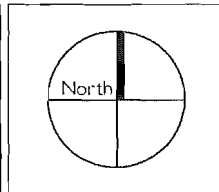
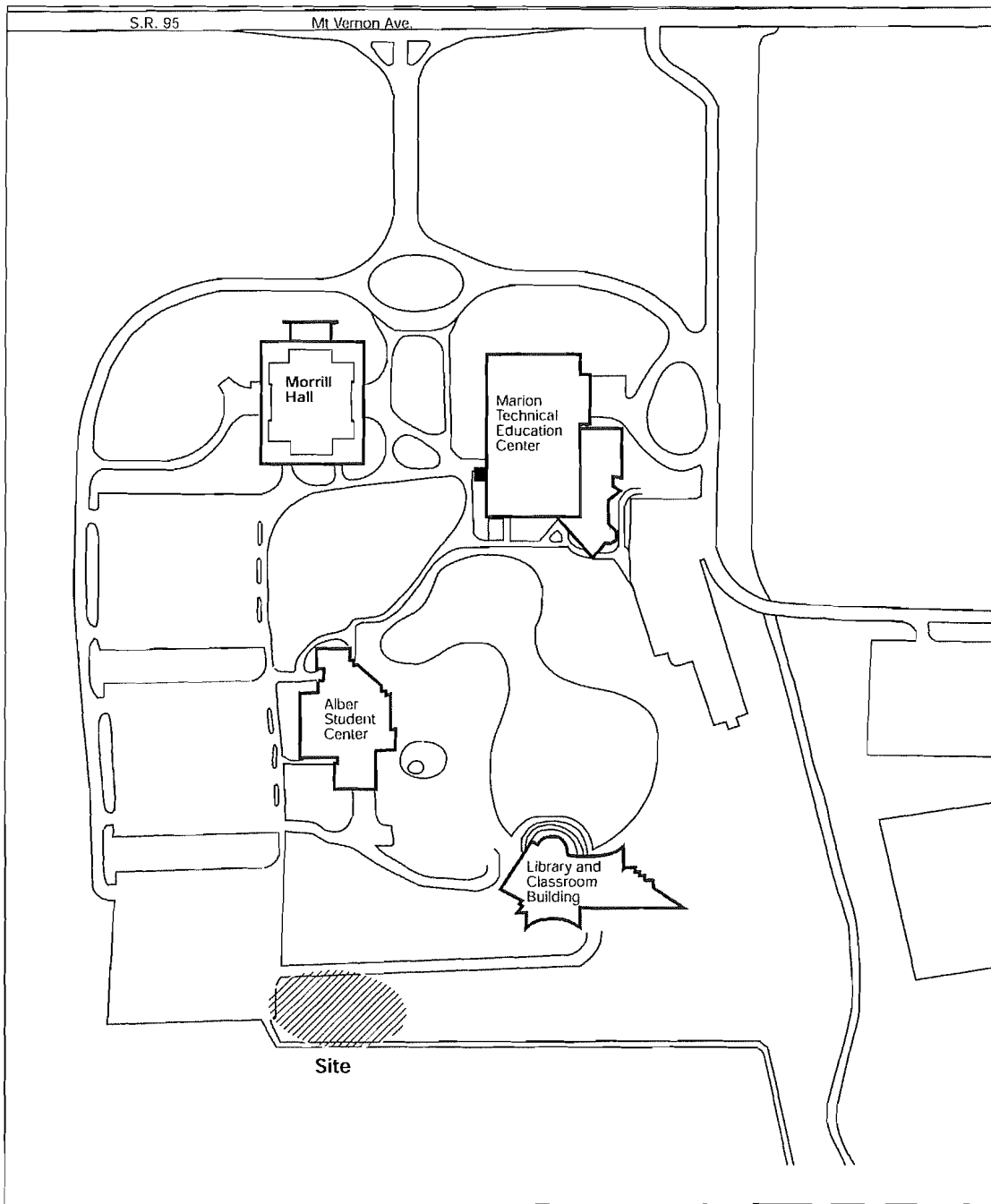

Office of Business and Finance
Office of the University Architect and Physical Planning

April 16, 2003



Put-In-Bay Water Line Extension

5062-PF6799

Requesting Agency(s): BUSINESS & FINANCE, OFFICE OF

Location(s): PEACH POINT, SOUTH BASS ISLAND

Gross Sq. Ft.2,013 **Age:** 1926

Description: Extend water and sewer service to both the Peach Point area and Gibraltar Island based on current and anticipated loads by the University. This will involve submerging pipes on the bottom of the lake between the islands, as well as trenching from the current termination of water & sewer service provided by the Village of Put-In-Bay up to the Peach Point area. The project will also upgrade the existing water & sewer pipes on Gibraltar Island.

Project Team:

Facility Planner: Is Unassigned

Project Captain: Bo Zhang
(zhang.403@osu.edu)

Project Assistant: Lisa Baldwin
(baldwin.10@osu.edu)

Field Coordinator: Is Unassigned

Project Information:

Additional funding would be required to do branch lines on Gibraltar Island.

Source of Funds:	Original	Revised	Uses of Funds:	As Designed	As Bid	Completion
Future Univ. Bond Issues	\$2,500,000.00	\$2,500,000.00				
Total:	\$2,500,000.00	\$2,500,000.00	Total:			

Schedule:	Projected	Revised	Actual
Planning			
Arch/Engr Approved by B/T	05/02/2003		
Arch/Engr Advertisement	05/30/2003		
Bidding Approved B/T	01/09/2004		
Design			
Arch/Engr Contract	06/30/2003		
Schematic Design Approval	08/01/2003		
Design Dev Document Approval	10/01/2003		
Construction Document Approval	12/01/2003		
Bidding			
Bid Opening	02/04/2004		
Construction			
Award of Contracts	04/15/2004		
Construction Start	04/15/2004		
Completion	10/31/2004		

Put-In-Bay Water Line Extension

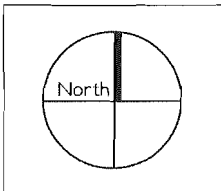
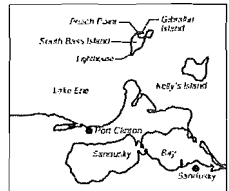
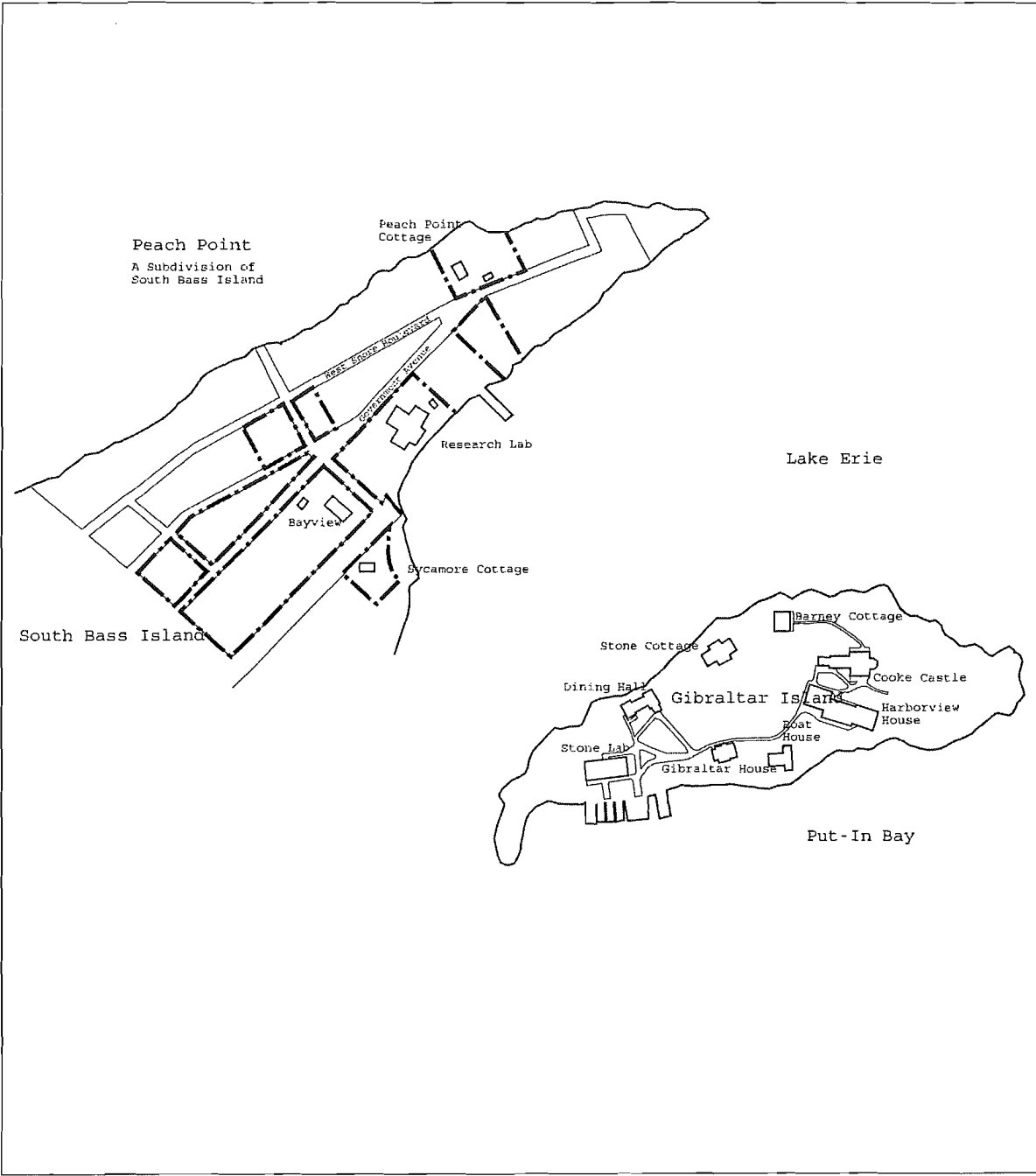

Office of Business and Finance
Office of Facilities Planning and Development

April 16, 2003



Biological Sciences -5th Floor Biosafety Level 3 Facility

315-2003-900

Requesting Agency(s): BIOLOGICAL SCIENCES ADMINISTRATION

Location(s): BIOLOGICAL SCIENCES BUILDING

Gross Sq. Ft. 182,129 **Age:** 1970

Description: Renovate rooms to meet current standards for a Bio Safety Level 3 facility. This includes a drop ceiling with out-of-room access to above-ceiling spaces for maintenance personnel; recessed lighting with weatherproof gaskets; weather-tight, self closing doors; an enlarged anteroom with key-card access and interlocking doors; campus phones; video surveillance system and ventilation system adjustments to maintain negative pressure in rooms.

Project Team:

Facility Planner: Is Unassigned

Project Captain: Steve Middleton
(middleton.52@osu.edu)

Project Assistant: Steve Deedrick
(deedrick.4@osu.edu)

Field Coordinator: Is Unassigned

Project Information:

Preliminary project budget of \$300,000.
Formerly known as 50700-R021701

Source of Funds:	Original	Revised	Uses of Funds:	As Designed	As Bid	Completion
General Funds-Biological Sciences	\$300,000.00	\$353,156.00				
Total:	\$300,000.00	\$353,156.00	Total:			

Schedule:	Projected	Revised	Actual
Planning			
Arch/Engr Approved by B/T (\$298,000 Project)	12/06/2002		12/06/2002
Bidding Approved B/T	05/02/2003		
Design			
Arch/Engr Contract	01/29/2003		01/29/2003
Construction Document Approval	03/11/2003		03/11/2003
Construction			
Construction Start	05/04/2003		
Completion	06/10/2003		

Biological Sciences Building - 5th Floor Biosafety Level 3 Facility

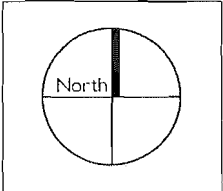
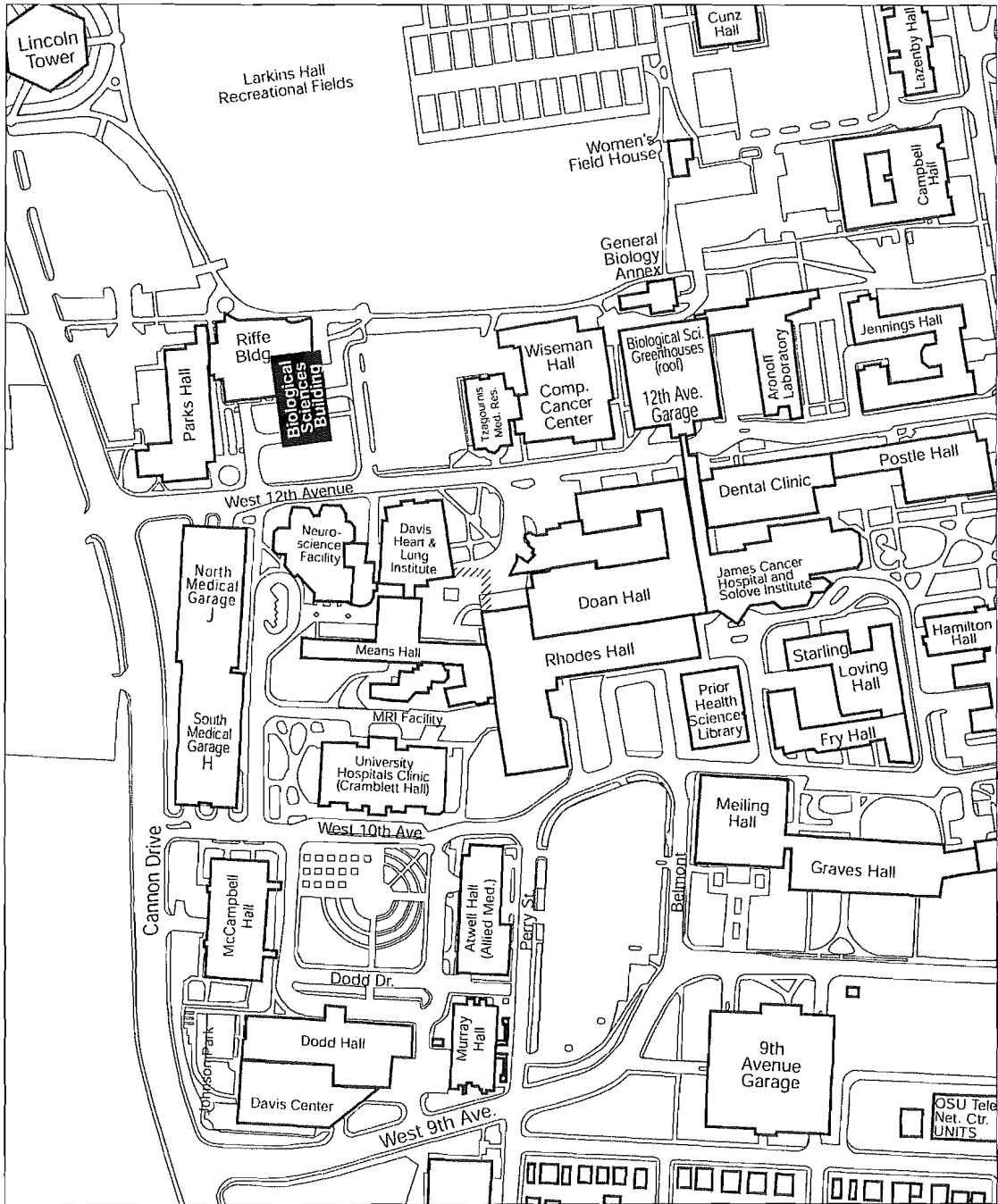

Office of Business and Finance
Office of Facilities Planning and Development

April 10, 2003



Campus Grounds - West Campus Pedestrian Bridge Repairs

315-2003-912

Requesting Agency(s): PHYSICAL FACILITIES

Location(s): Site - See Comments.

Gross Sq. Ft.0 Age:

Description: This project will replace two pedestrian bridges across Carmack Road in front of Bevis Hall on west campus. The superstructures of the existing bridges, made of weathering steel with timber deck, have deteriorated after 12 years in existence. The replacement bridges will have a new painted steel superstructure with structural concrete deck.

Project Team:

Project Information:

Facility Planner: Is Unassigned

Project Captain: Brett Garrett

Project Assistant: Karen Cogley
(cogley.1@osu.edu)

Field Coordinator: Is Unassigned

Source of Funds:	Original	Revised	Uses of Funds:	As Designed	As Bid	Completion
HB675 Columbus Basic	\$260,000.00	\$260,000.00				
Renovation			Total:			
Total:	\$260,000.00	\$260,000.00				

Schedule:	Projected	Revised	Actual
Planning			
Bidding Approved B/T (\$260,000 Project)	04/04/2003		
Design			
Schematic Design Approval	03/03/2003	03/28/2003	03/19/2003
Design Dev Document Approval	04/17/2003		
Construction Document Approval	06/16/2003		
Bidding			
Bid Opening	09/14/2003		
Construction			
Construction Start	11/13/2003		
Report of Award to B/T	12/05/2003		
Completion	03/12/2004		

Campus Grounds - West Campus Pedestrian Bridge Repairs

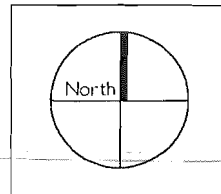
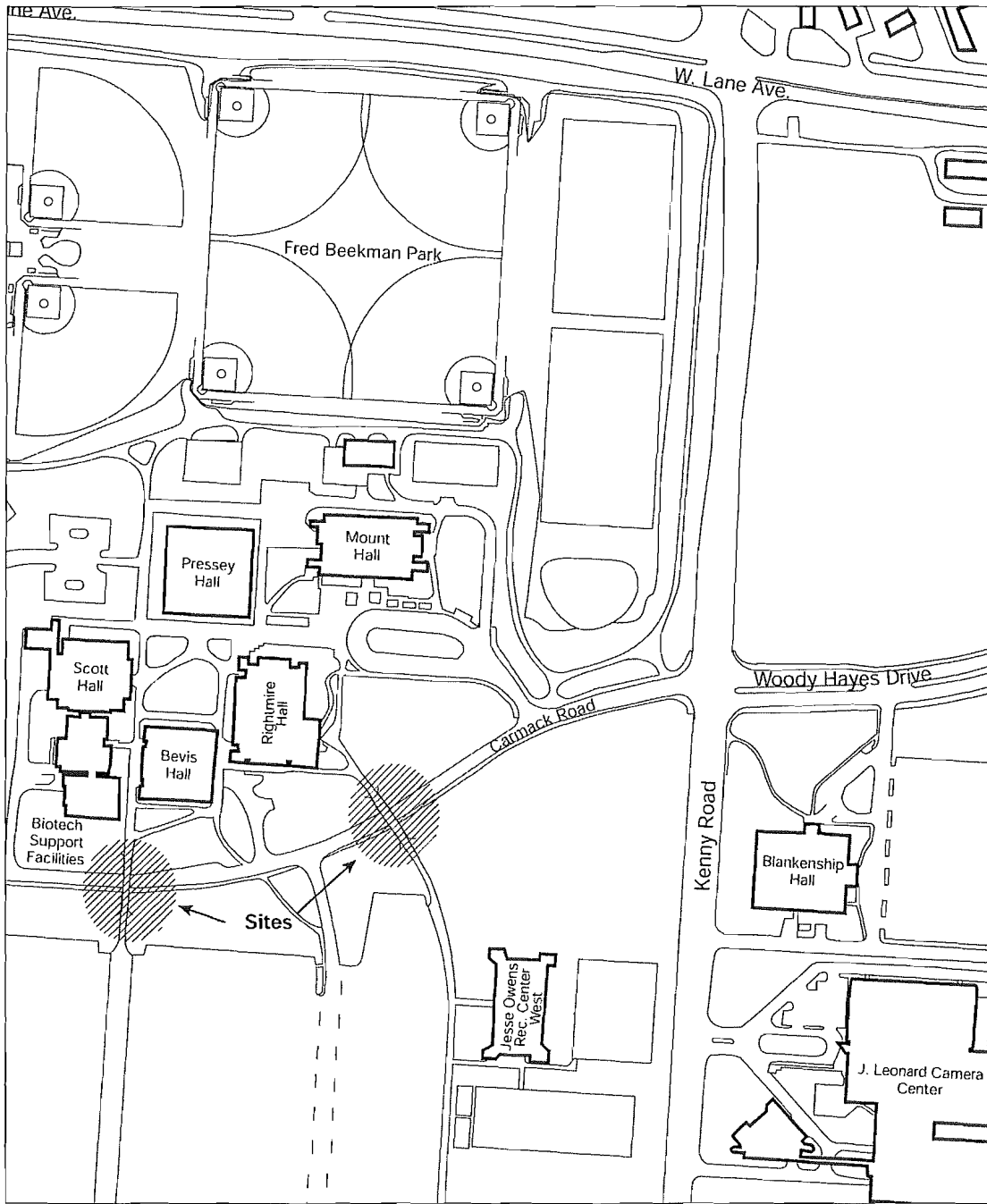

Office of Business and Finance
Office of Facilities Planning and Development

March 13, 2003



Doan Hall 11 - Infectious Diseases

315-2002-930

Requesting Agency(s): HEALTH SCIENCES ADMINISTRATION

Location(s): DOAN HALL, CHARLES AUSTIN

Gross Sq. Ft. 669,869 **Age:** 1951

Description: Renovation of 11th floor of Doan Hall to consolidate Infectious Diseases office space, including space for the new Office Chair.

Project Team:

Facility Planner: Is Unassigned

Project Captain: Richard Van Deusen
(van-deusen.2@osu.edu)

Project Assistant: Patricia Berger
(berger.58@osu.edu)

Field Coordinator: Is Unassigned

Project Information:

Formerly known as 50700-R025184.
Preliminary project budget of \$412,000.

Source of Funds:	Original	Revised	Uses of Funds:	As Designed	As Bid	Completion
Auxiliaries-University	\$411,575.00	\$560,276.00				
Hospitals			Total:			
Total:	\$411,575.00	\$560,276.00				

Schedule:	Projected	Revised	Actual
Planning			
Arch/Engr Approved by B/T (\$412,000 Project)	12/06/2002		12/06/2002
Bidding Approved B/T	05/02/2003		
Design			
Schematic Design Approval	12/24/2002		12/24/2002
Design Dev Document Approval	01/15/2003		01/15/2003
Construction Document Approval	02/03/2003		02/03/2003
Bidding			
Bid Opening	05/02/2003		
Construction			
Construction Start	05/05/2003		
Completion	05/31/2003		

Doan Hall II - Infectious Diseases

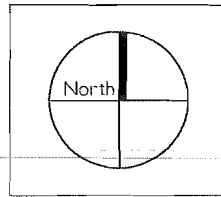
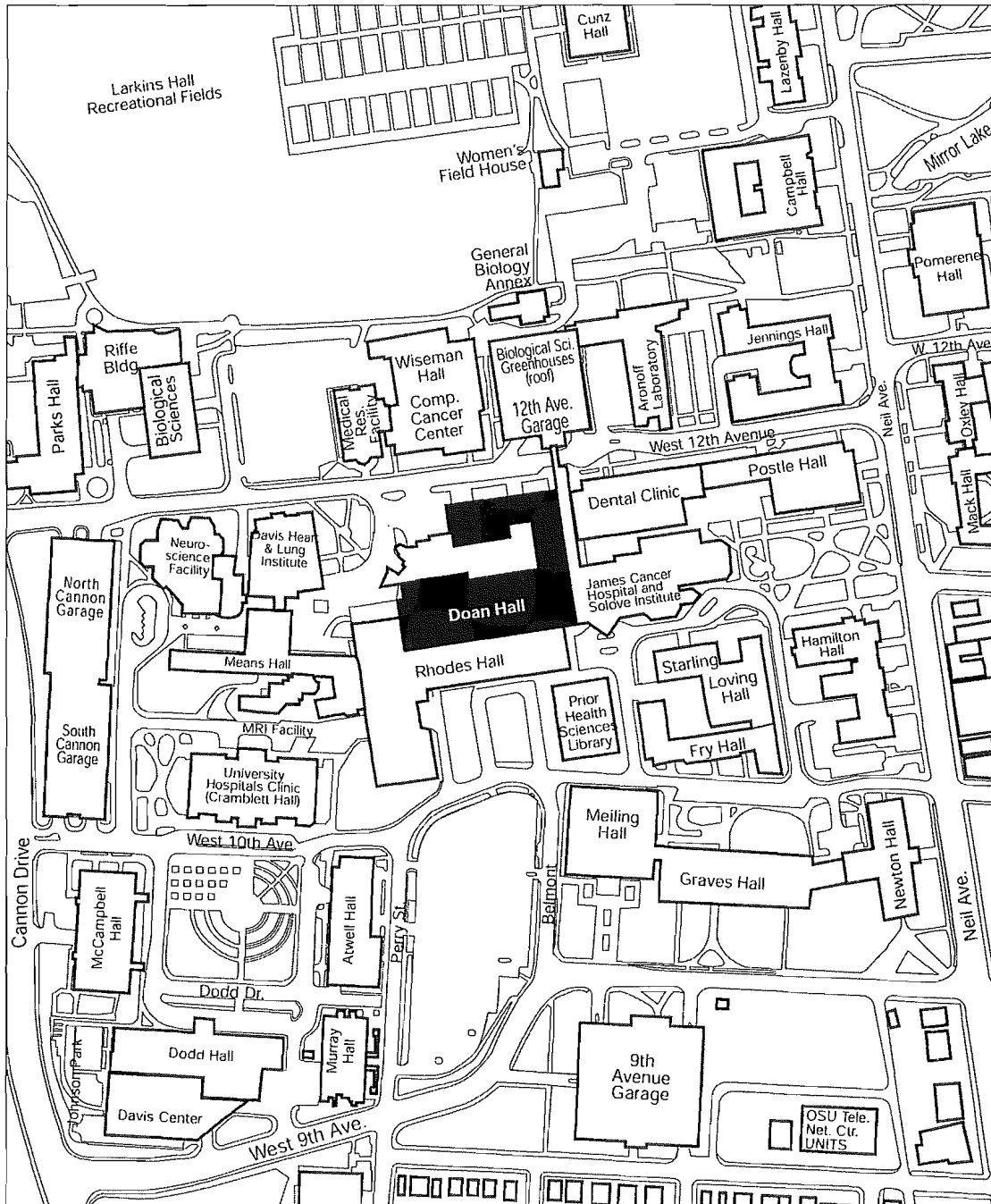

Office of Business and Finance
Office of Facilities Planning and Development

November 14, 2002



Football Practice Field #4 - Turf Installation

315-2003-903

Requesting Agency(s): ATHLETICS

Location(s): Site - See Comments.

Gross Sq. Ft.0 Age:

Description: Replace turf surface on football field four with an infill artificial surface. Complete with pad layer, diagonal, and field markings.

OFP #03-18

Project Team:

Facility Planner: Is Unassigned

Project Captain: Thomas Heretta
(heretta.1@osu.edu)

Project Assistant: Curt Handschug
(handschug.1@osu.edu)

Field Coordinator: Is Unassigned

Project Information:

Formerly known as project 50700-R031714
Preliminary project budget of \$540,000

Source of Funds:	Original	Revised	Uses of Funds:	As Designed	As Bid	Completion
Auxiliaries-Athletics	\$540,000.00	\$540,000.00				
Total:	\$540,000.00	\$540,000.00	Total:			

Schedule:	Projected	Revised	Actual
Planning			
Arch/Engr Approved by B/T (\$540,000 Project)	02/07/2003		02/07/2003
Bidding Approved B/T (\$540,000 Project)	05/02/2003		
Design			
Construction Document Approval	04/18/2003		
Bidding			
Bid Opening	05/13/2003		
Construction			
Construction Start	06/27/2003		
Completion	07/27/2003		

Football Practice Field #4 - Turf Replacement

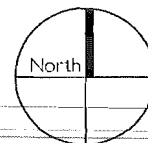
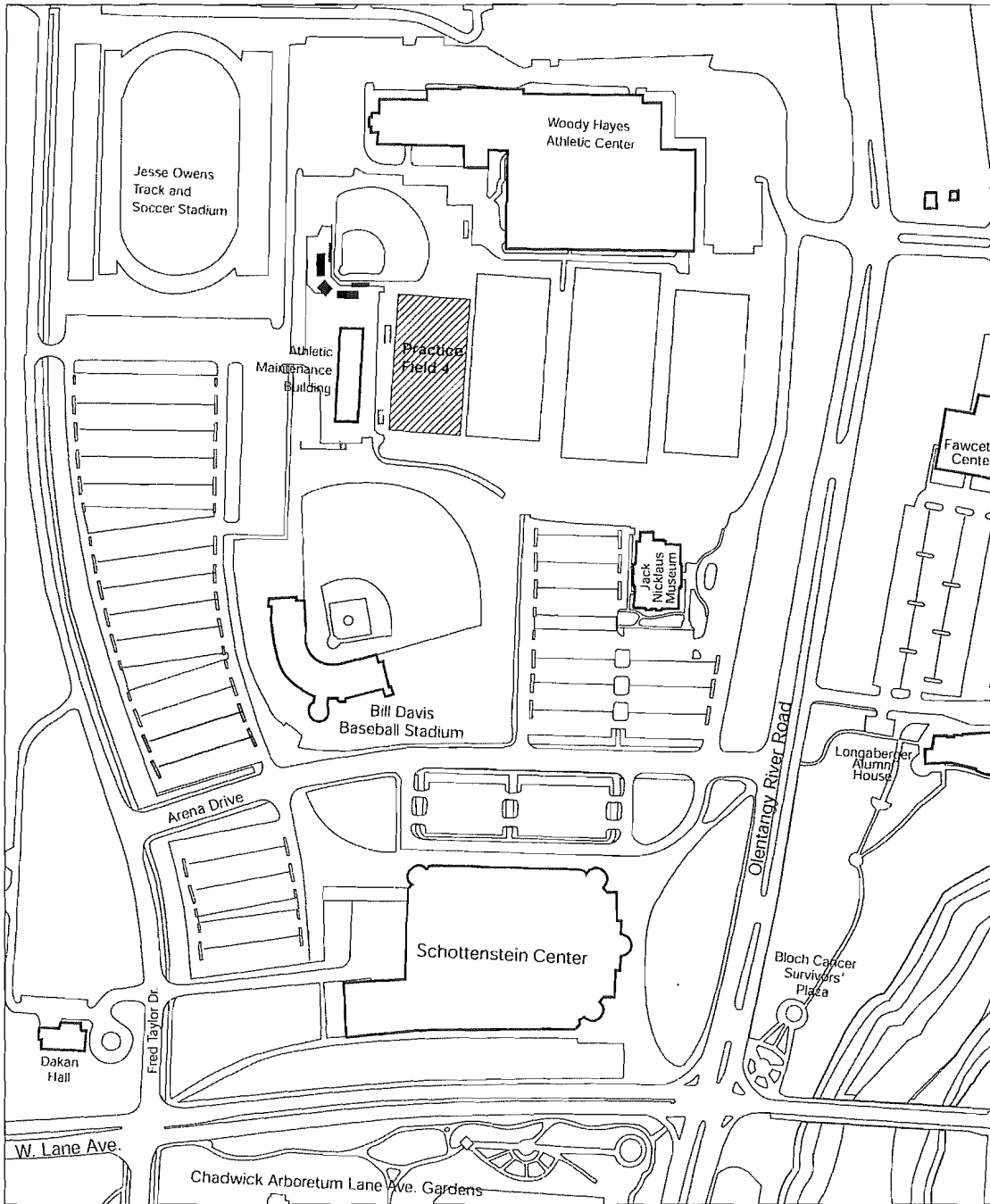

Office of Business and Finance
Office of Facilities Planning and Development

April 16, 2003

Job Order Contract 2003 Camera Center

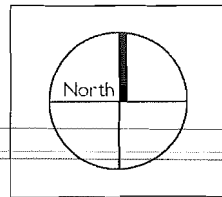
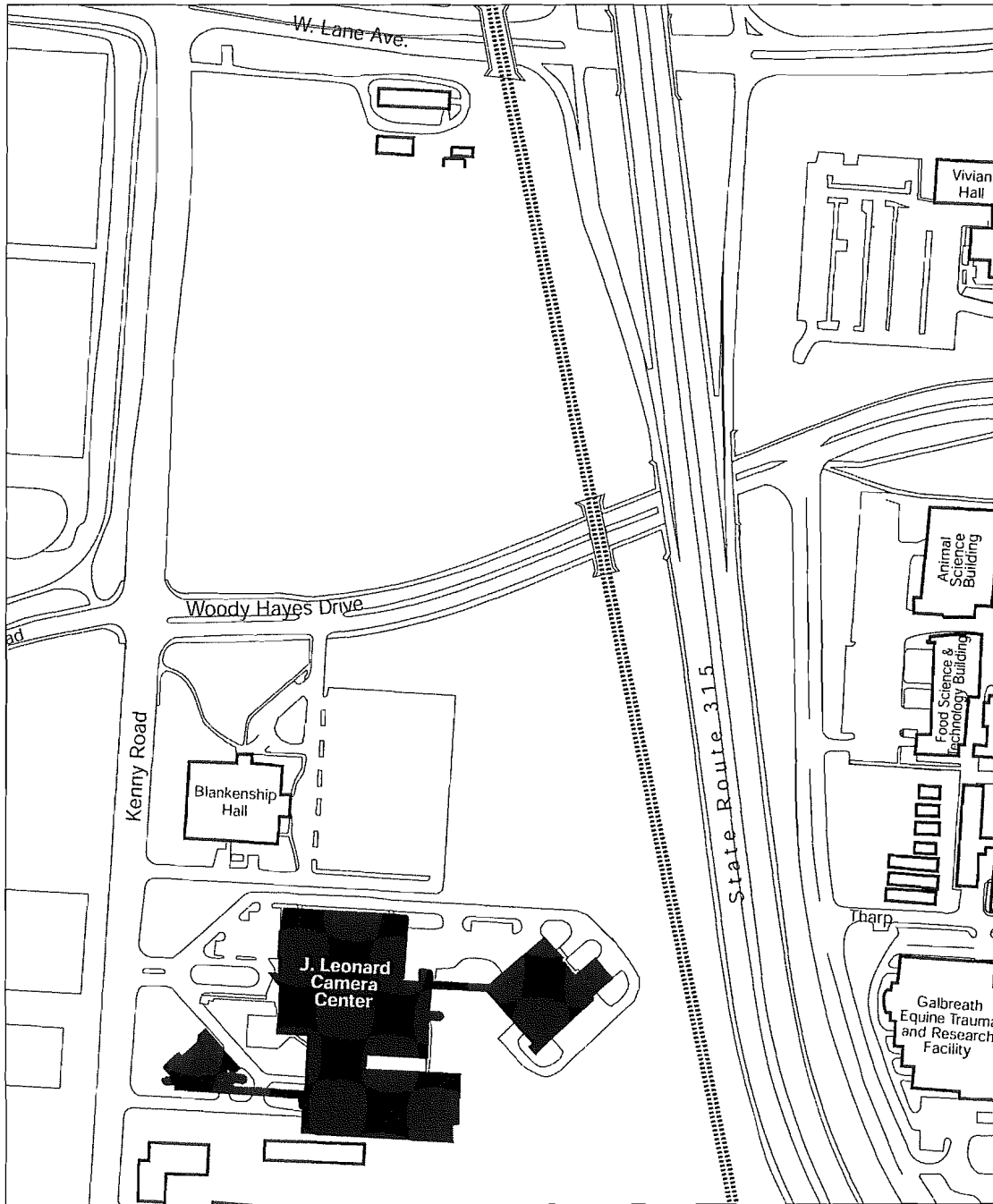

Office of Business and Finance
Office of Facilities Planning and Development

April 10, 2003



OARDC - Hayden Hall Renovation

315-2001-909

Requesting Agency(s): OHIO AGRIC RESEARCH & DEVELOPMENT CTR

Location(s): HAYDEN HALL

Gross Sq. Ft.6,974 Age: 1913

Description: Upgrade existing laboratories, refurbish office spaces, install a new passenger elevator, install new central HVAC system, and reconstruct the restroom facilities in Hayden Hall on the OARDC campus.

Project Team:

Facility Planner: Is Unassigned

Project Captain: Marjory Spangler
(spangler.40@osu.edu)

Project Assistant: Steve Deedrick
(deedrick.4@osu.edu)

Field Coordinator: Marjory Spangler
(spangler.40@osu.edu)

Project Information:

Project budget increased due to revisions in the HVAC system from a two pipe to a four pipe system; revisions to the reverse osmosis water system; and unforeseen site conditions related to utility line locations.

Source of Funds:	Original	Revised	Uses of Funds:	As Designed	As Bid	Completion
HB790 Columbus ADA	\$100,000.00	\$150,000.00				
Modifications			Total:			
OARDC	\$750,000.00	\$820,760.00				
HB675 Regional Basic	\$0.00	\$60,000.00				
Renovation						
Total:	\$850,000.00	\$1,030,760.00				

Schedule:	Projected	Revised	Actual
Planning			
Arch/Engr Approved by B/T (\$850,000 Project)	06/01/2001		06/01/2001
Bidding Approved B/T (\$850,000 Project)	06/01/2001		06/01/2001
Bidding Approved B/T (\$1,030,760 Project)	05/02/2003		
Design			
Schematic Design Approval	10/08/2001	07/15/2002	07/15/2002
Design Dev Document Approval	11/20/2001	08/30/2002	08/30/2002
Construction Document Approval	01/22/2002	12/04/2002	12/15/2002
Bidding			
Bid Opening	02/12/2002	12/25/2002	01/28/2003
Construction			
Award of Contracts	04/12/2002	04/24/2003	
Construction Start	04/12/2002	04/28/2003	
Report of Award to B/T	12/06/2002	06/06/2003	
Completion	10/06/2002	10/21/2003	

OARDC - Hayden Hall Renovation

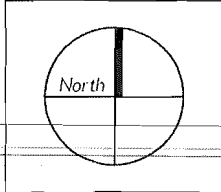
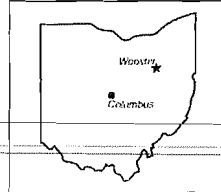
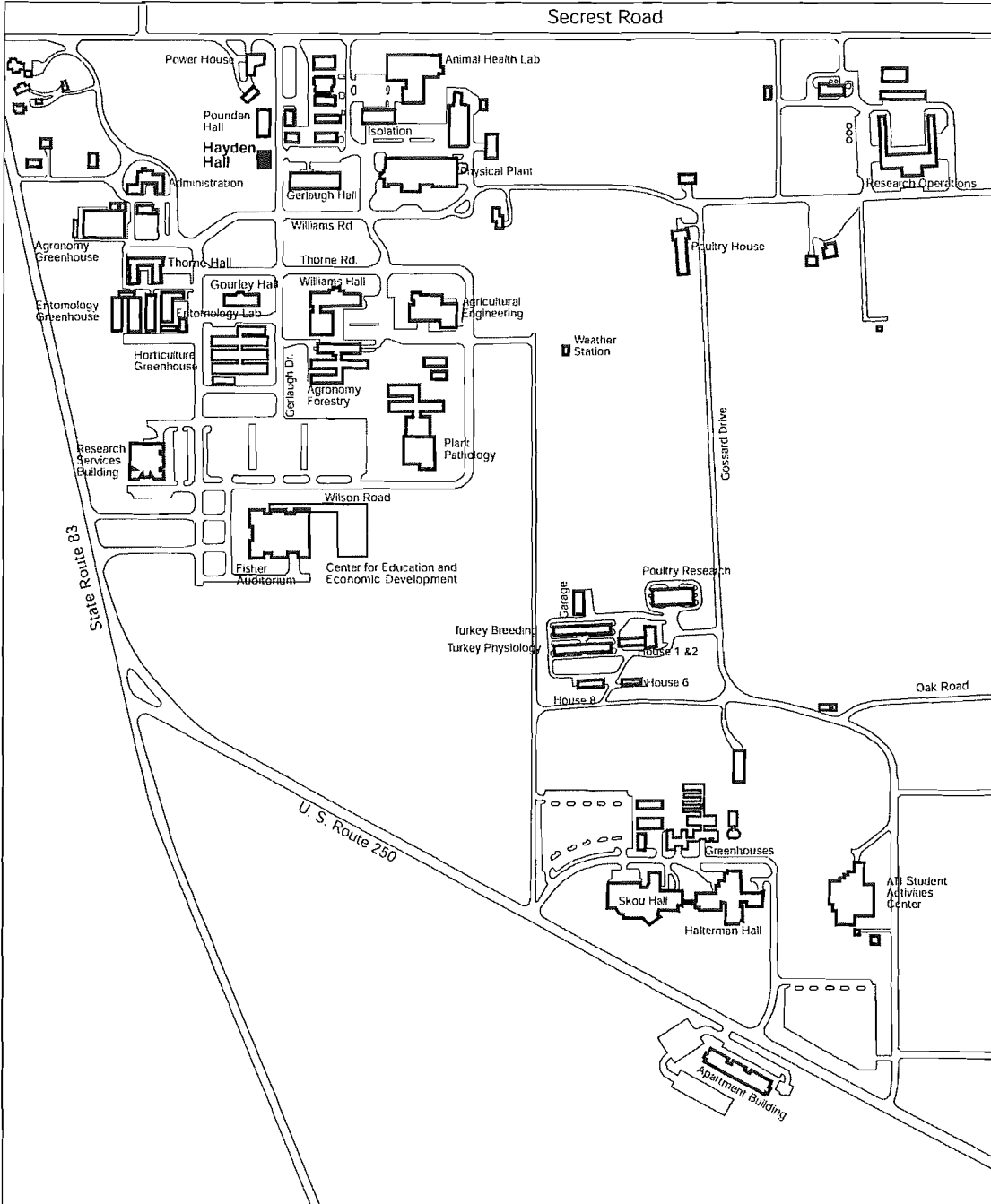

Office of Business and Finance
Office of Facilities Planning and Development

May 16, 2001



Student Family Community Center at Buckeye Village

315-1999-941

Requesting Agency(s): STUDENT AFFAIRS, OFFICE OF

Location(s): Site - See Comments.

Gross Sq. Ft.0 Age:

Description: Construction of a new community facility to provide an integrated approach to addressing the needs of OSU Child Care Center and ACCESS Program for single parents and providing a new community facility at Buckeye Village. The new facility will provide space for administrative and maintenance offices, satellite child care center, recreation area, laundry facility, computer lab, aerobic fitness room, and meeting rooms.

Project Team:

Facility Planner: Cheryl Christie
 (christie.2@osu.edu)
 Project Captain: Ruth Miller
 (miller.2495@osu.edu)
 Project Assistant: Steve Deedrick
 (deedrick.4@osu.edu)
 Field Coordinator: Is Unassigned

Project Information:

Source of Funds:	Original	Revised	Uses of Funds:	As Designed	As Bid	Completion
Future Univ. Bond Issues	\$5,400,000.00	\$5,676,310.00				
Total:	\$5,400,000.00	\$5,676,310.00	Total:			

Schedule:	Projected	Revised	Actual
Planning			
Arch/Engr Approved by B/T (\$250,000 Planning)	02/02/2001		02/02/2001
Bidding Approved B/T (\$5,400,000 Project)	02/02/2001	07/12/2002	07/12/2002
Design			
Arch/Engr Contract	07/01/2001	02/01/2002	02/01/2002
Schematic Design Approval	10/01/2001	02/14/2002	02/14/2002
Design Dev Document Approval	02/15/2002	07/26/2002	07/31/2002
Construction Document Approval	05/15/2002	12/19/2002	12/05/2002
Bidding			
Bid Opening	08/01/2002	04/15/2003	
Construction			
Construction Start	10/15/2002	06/09/2003	
Award of Contracts	10/01/2002	07/08/2003	
Report of Award to B/T	11/01/2002	08/08/2003	
Completion	09/15/2003	07/19/2004	

Student Family Community Center at Buckeye Village

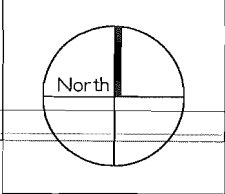
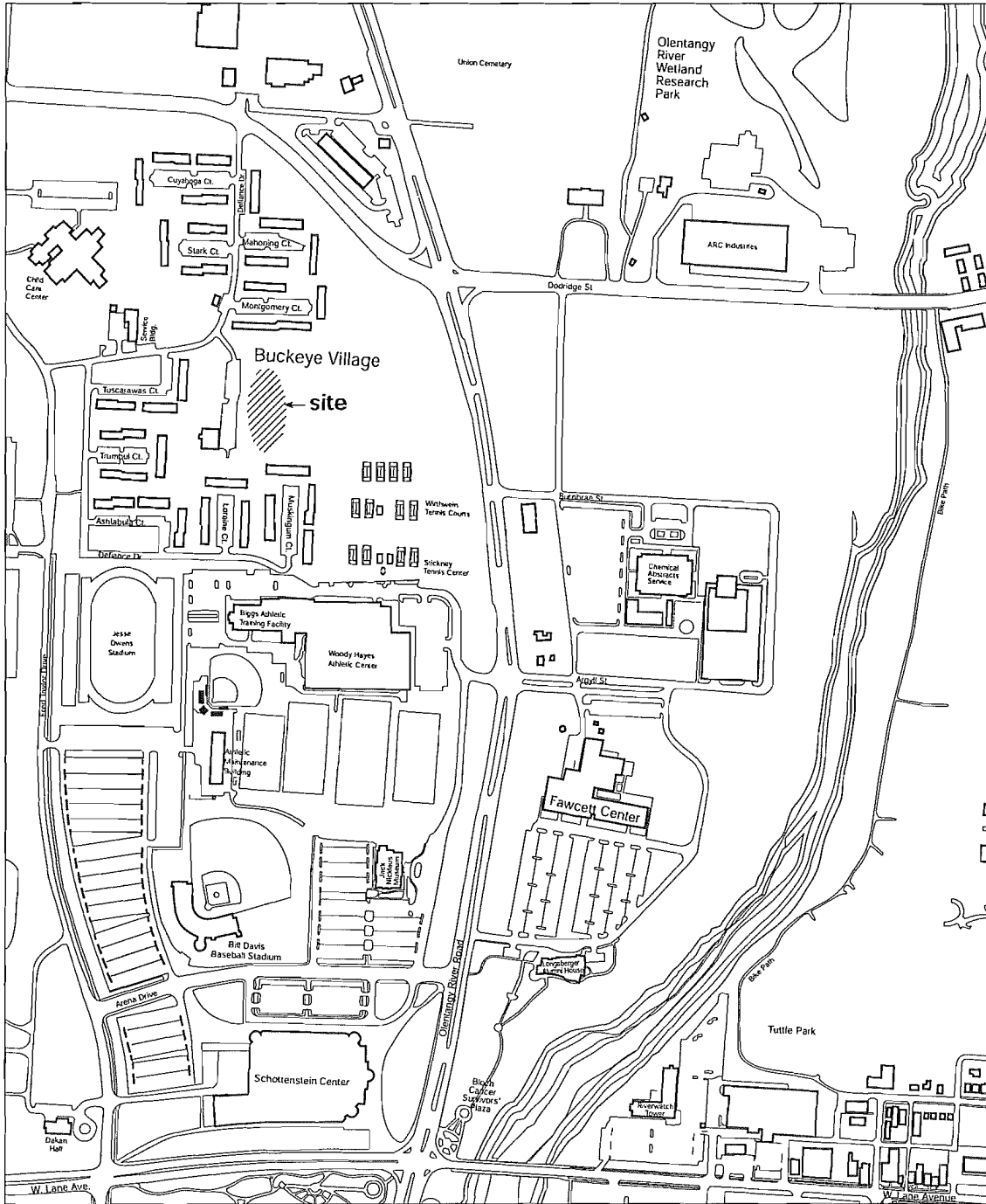

Office of Business and Finance
Office of Facilities Planning and Development

June 15, 2002



Woody Hayes Athletic Center - Turf Replacement

315-2003-902

Requesting Agency(s): ATHLETICS

Location(s): WOODY HAYES ATHLETIC CENTER

Gross Sq. Ft.170,270 Age: 1987

Description: Replacement of the artificial turf on the indoor football field in the Woody Hayes Athletic Center (WHAC).

Project Team:

Facility Planner: Is Unassigned

Project Captain: Thomas Heretta
(heretta.1@osu.edu)

Project Assistant: Curt Handschug
(handschug.1@osu.edu)

Field Coordinator: Is Unassigned

Project Information:

Formerly known as 50700-R021688
Preliminary project budget of \$480,000

Source of Funds:	Original	Revised	Uses of Funds:	As Designed	As Bid	Completion
Auxillaries-Athletics	\$480,000.00	\$480,000.00				
Total:	\$480,000.00	\$480,000.00	Total:			

Schedule:	Projected	Revised	Actual
Planning			
Arch/Engr Approved by B/T (\$480,000 Project)	02/07/2003		02/07/2003
Bidding Approved B/T (\$480,000 Project)	05/02/2003		
Design			
Construction Document Approval	04/18/2003		
Bidding			
Bid Opening	05/13/2003		
Construction			
Construction Start	06/27/2003		
Completion	07/27/2003		

Woody Hayes Athletic Center - Turf Replacement

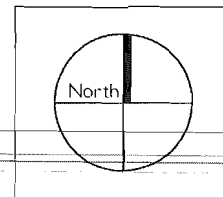
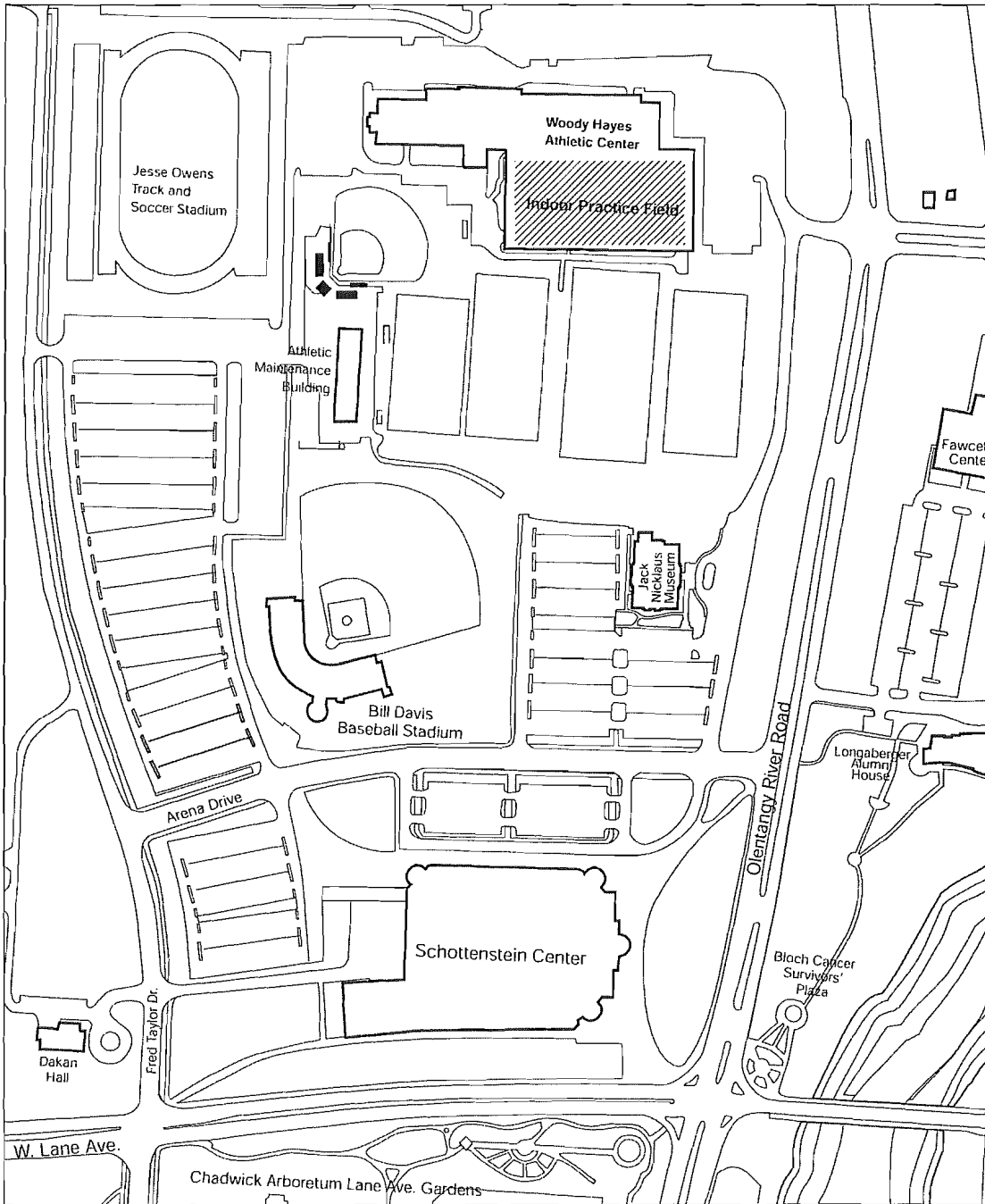

Office of Business and Finance
Office of Facilities Planning and Development

April 16, 2003

(APPENDIX XLVIII)

PURCHASE OF REAL PROPERTY

226 West Ninth Avenue, Columbus, Ohio
218-220 West Ninth Avenue, Columbus, Ohio
208-212 West Ninth Avenue, Columbus, Ohio
1549-1569 Worthington Street, Columbus, Ohio

Location and Description

The properties to be purchased are located in Columbus, Ohio, at 226 West Ninth Avenue (a 10-unit apartment building); 218-220 West Ninth Avenue (a duplex); 208-212 West Ninth Avenue (a four-unit townhouse building); and 1549-1569 Worthington Street (a six-unit townhouse building). The properties are owned by Thomas D. Thompson and Charles R. Dersom, Trustees. The properties, totaling approximately 0.57 acres, are adjacent to the site of the University's graduate and professional student housing project and just outside the University's South Campus acquisition area.

Appraisals and Consideration

Two MAI appraisals conducted in June 2002 by Ohio Real Estate Consultants and Reith Real Estate Services valued the properties at \$970,000 and \$760,000, respectively. The purchase price is \$845,000.00. All acquisition and operating expenses will be funded by the Office of Student Affairs.

Use of the Property

Title to the property will be taken in the name of the State of Ohio for the use of The Ohio State University. Student Affairs will use the properties for student housing or for a combination of student and visiting faculty/scholar housing. Although the properties are outside the acquisition area, the proposed use is consistent with the University Master Plan. The University has consulted with neighborhood organizations regarding this proposed acquisition. To respond to community concerns about possible future University uses of the property, the University proposes to acquire the properties with the current AR-4 zoning classification, rather than seeking rezoning to the University's standard UCRPD classification. This approach would assure that if, in the future, the University might propose a use that would require some zoning change or modification, the University would be subject to the same zoning regulations as any other property owner.

Proposed Purchase of Real Property

1549-1569 Worthington Street, 208-212 W. Ninth Avenue
218-220 W. Ninth Avenue, 226 Ninth Avenue

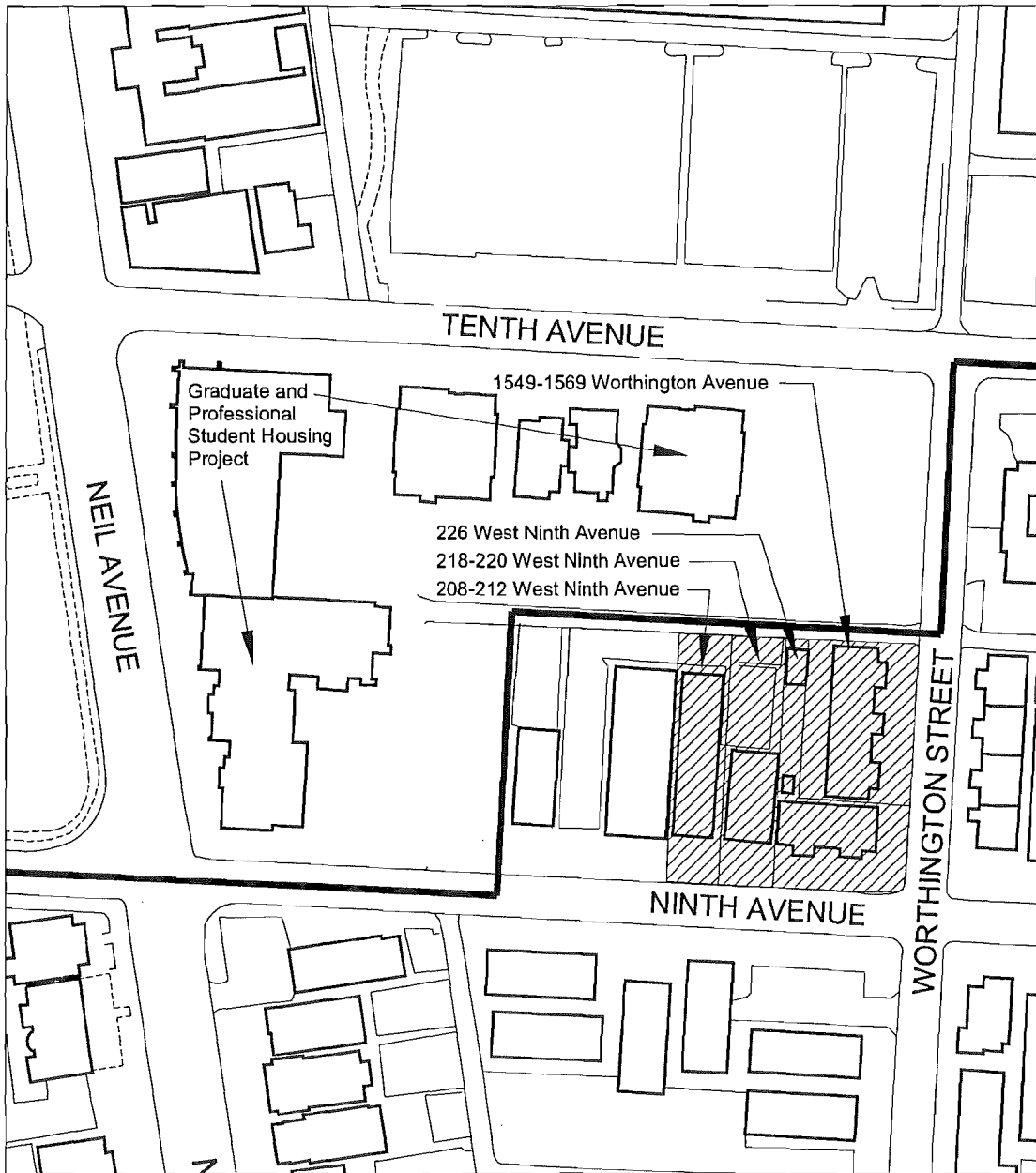

No True Scale



Office of Business and Finance
Board of Trustees Meeting
May 2, 2003

Map Provided by University Engineer's Office

- Proposed Purchase
- Southern Boundary of South Campus Acquisition Area

(APPENDIX XLIX)

The Ohio State University Board of Trustees

May 2, 2003

Undergraduate Instructional and General Fee
Increase
Summer 2003 Recommendations

**Summer 2003
Undergraduate Tuition Increase Recommendation**

Principles

The University is guided by the following principles, consistent with the Academic Plan, in recommending the tuition strategy for the coming year:

1. We need to maintain our commitment to enhancing academic quality (even during the current recession), as this is critical to our students, Ohio's longer-term economic vitality, and competitiveness.
 2. We need to continue to do all we can internally to reduce costs and program new and existing resources to offset the state budget reductions and address competitive compensation needs.
 3. Our tuition policy should be as fair as possible to current undergraduate students, placing a greater responsibility on incoming students.
 4. Financial aid must increase so that students who meet academic requirements and qualify for financial aid will still be able to attend Ohio State.
 5. A high priority for use of the increased resources will be to preserve and improve the quality of the student experience both inside and outside the classroom.
 6. The summer tuition recommendations are consistent with the Governor's proposed fee caps and higher education funding levels for FY 04.
-
-

Columbus Campus Undergraduate Recommendations

For all continuing undergraduates¹ there would be a 9% increase in instructional and general fees beginning Summer Quarter 2003. For new students² there will be an additional \$100 per quarter increase in the instructional fee above the recommended 9% increase for Tier 2 students. Over an academic year (three quarters) this will amount to:

- Tier 1 - \$468 increase from \$5,190 to \$5,658 for full-time continuing undergraduates who were first enrolled at Ohio State prior to Summer Quarter 2002
- Tier 2 - \$510 increase from \$5,664 to \$6,174 for full-time continuing undergraduates who were first enrolled at Ohio State between Summer Quarter 2002 and Spring Quarter 2003.
- Tier 3 - \$100 additional increase per quarter above Tier 2 (An additional \$300 increase to \$6,474) for new full-time students who will first enroll at Ohio State for Summer Quarter 2003 or beyond.

25% of the proposed additional \$100 per quarter increase for new students will be earmarked to increase student financial aid funds to assure that students who are otherwise qualified will be afforded access.

¹ Students who were enrolled prior to Summer Quarter, 2003.

² Students who will enroll for the first time for Summer Quarter, 2003 or later.

Regional Campus Undergraduate Recommendations

For all undergraduates at the Agricultural Technical Institute and the regional campuses there would be a 6% increase in instructional and general fees beginning Summer Quarter 2003. Over an academic year (three quarters) this will amount to:

- \$273 increase from \$4,527 to \$4,800 for full-time undergraduates at Regional Campuses.
- \$270 increase from \$4,512 to \$4,782 for full-time undergraduates at ATI.
- The Access Challenge offset at ATI and the Regional Campuses will not change for Summer Quarter 2003 but is subject to change for the academic year starting Autumn Quarter 2003 pending the level of Access funding provided in the State Budget.

Ohio State will remain affordable

Ohio State will remain affordable compared with other public universities, even if those universities increase FY 2004 tuition by a smaller percentage amount.

For example, if other Ohio universities increase tuition by 6% and we increase tuition by 9% in accordance with the Governor's budget proposal, Ohio State will rank:

- 8th out of 13 for students first enrolled prior to Summer 2002, and
- 6th out of 13 for students enrolling for the first time Summer 2003.

Students Enrolled Prior to Summer 2002

Compared with other Ohio universities, tuition for students first enrolled prior to Summer Quarter 2002 at Ohio State will remain below average.

Possible Fall 2003 Tuition Ohio State v. Other Ohio Publics

University	FY 2003 Tuition	FY 2004 Assumed Tuition
Miami	\$7,600	\$8,056
University of Cincinnati	6,936	7,352
Bowling Green	6,502	6,892
Kent State	6,374	6,756
Ohio University	6,036	6,398
Toledo	5,848	6,198
Akron	5,798	6,146
Ohio State	5,190	5,658
Cleveland State	5,196	5,508
Wright State	5,163	5,472
Youngstown State	4,996	5,296
Shawnee State	4,050	4,292
Central State	4,044	4,286
Average	\$5,672	\$6,024

Note: Projection for illustrative purposes only. Assumes a 9% increase for Ohio State and a 6% increase for all other Ohio universities per the Governor's budget proposal. Actual increase will be determined by those institutions and may vary.

New Students

Tuition for students enrolling for the first time Summer Quarter 2003 and beyond will likely be about average for new students at other Ohio publics, even if the percentage increase at other schools is less.

Possible Fall 2003 Tuition Ohio State v. Other Ohio Publics

University	FY 2003 Tuition	FY 2004 Assumed Tuition
Miami	\$7,600	\$8,056
University of Cincinnati	6,936	7,352
Bowling Green	* 6,742	7,147
Kent State	6,374	6,756
Ohio University	* 6,336	6,716
Ohio State	* 5,664	** 6,474
Akron	* 6,098	6,464
Toledo	5,848	6,198
Cleveland State	* 5,496	** 6,126
Wright State	* 5,361	** 5,983
Youngstown State	4,996	** 5,296
Shawnee State	* 4,347	** 4,908
Central State	4,044	** 4,286
Average	\$5,834	\$6,289

NOTE: Projected tuition is for illustrative purposes only. Assumes a 9% increase for Ohio State and a 6% increase for all other Ohio universities plus an additional \$300 for Ohio State and any other university whose fees were below the average in FY 2003 per the Governor's budget proposal. Actual increases will be determined by each institution and may vary.

* Denotes universities with higher first-year student fees in FY 2003.

** Denotes universities eligible to increase first-year student tuition an additional \$300 in FY 2004.

Implications

- A. Progress on academic goals will be maintained, but at a slower pace. The phased in nature of the higher tuition on new students will provide a steady stream of \$6-7 million in additional funds net of financial aid annually to help support the Academic Plan over the next 5 years.
- B. Access for academically qualified students will be maintained.
- C. Students will benefit directly.
- D. Proposed tuition levels are consistent with those included in the Governor's budget proposal but due to uncertainty of the state budget picture for FY 2004 and FY 2005, these recommended tuition levels may be subject to modification at a subsequent date.
- E. Ohio State will remain a unique combination of excellence and affordability.

(APPENDIX L)

**The Ohio State University Board of Trustees
Fiscal Affairs Committee**

MAY 2, 2003

TOPIC:

Third Quarter Financial Report

CONTEXT:

This is the third in a series of quarterly financial reports for FY 2003.

HIGHLIGHTS:

General Fund

- Enrollments for Summer through Spring Quarters were slightly higher than projected but the composition was different (Attachment A)
 - Total enrollments are up slightly (1.1%) but nonresident enrollments are down 2.4%. Undergraduate enrollments are up 1.6% while graduate enrollments are down 1.1%.
 - Financial impact on tuition revenue is plus \$2.7 million increase in the Columbus Campus student fees revenue category. It is recommended the additional fee revenue be recognized at this time.
- Total state support has been reduced by \$11.2 million or 2.5% for FY 2003..
 - Cuts to the State Share of Instruction (SSI) to the Columbus Campus totaled \$7.7 million and was partially offset by an increase of \$2.4 million over our Spring estimates based on numbers provided by the Board of Regents.
 - A reduction plan approved at the March 5 Board of Trustees meeting addressed this cut with one-time reallocations from the colleges and support units in FY 2003.
 - The permanent reduction of college and support unit budgets will be addressed in the FY 2004 budget scheduled to be voted on at the July meeting.
 - The 2.5% cuts to other line items and the Regional Campus SSI is reflected in the FY 2003 Third Quarter Budget revision.
- Indirect cost recoveries (IDCRs) are higher than projected
 - Through the Third quarter, IDCRs are 11.0% higher than in FY 2002 compared to a 3.5% budgeted increase. An additional 3.5% (\$1.8M) increase in the budget was approved in the Second Quarter Report.
 - An additional 2.0% (\$1.0M) increase is recommended at this time to be added to the budget.

Non-General Fund

- Ohio State University Health System financial results to date are better than budget and last year (Attachment B)
 - First nine months shows a \$4.9 million gain compared with last year:
 - Minus \$1.8 million first nine months actual last year
 - Plus \$1.4 million first nine months budget target this year
 - There has been no significant change in the status of the Hospital Self Insurance Fund or the Oval Ltd., the University's captive insurance company, since the second quarter report to the Board.

- Auxiliaries
 - Athletics operations are within budget with some revenue and related expense running ahead of a year ago due to increased merchandise sales.
 - The Schottenstein Center is operating within budget.
 - The Blackwell Inn is making positive strides since the last quarterly report. Monthly occupancy rates have increased each month. At the same time, the average daily room rate is higher than expected. Year-end operations should either break even or record a small loss.

RECOMMENDATION:

Approval of the attached resolution.

HEADCOUNT ENROLLMENTS
SUMMER 2002 THROUGH SPRING 2003

Category	Projected ³	Actual ⁴	Difference	%
Undergraduate	116,650	118,575	+1,925	+1.6%
Graduate	36,841	36,438	-403	-1.1%
Professional	9,279	9,510	+231	+2.5%
Total	162,770	164,523	+1,753	+1.1%

NOTE: Includes total of Summer, Autumn, Winter and Spring Quarters

SOURCE: Resource Planning

³ Projected in May for FY 2003 budget

⁴ Reflects 14th day enrollment counts

THE OHIO STATE UNIVERSITY HEALTH SYSTEM
FINANCIAL SUMMARY

YTD ENDING MARCH 31, 2003
(IN THOUSANDS)

Category	Actual 2003	Budget 2003	Actual 2002
Net Patient Revenue	\$551,279	\$559,067	\$492,563
Other Income	58,920	55,058	26,342
Total Income	610,199	614,125	518,905
Expenses	605,296	612,697	520,671
Revenue over Expenses	\$ 4,903	\$ 1,428	\$ (1,766)

- Financial results are better than budget and last year.
 - First nine months gain of \$4.9 million compared with last year
 - Budget gain of \$1.4 million first nine months this year
 - Loss of \$1.8 million first nine months actual last year
- Year to date Net Days in Accounts Receivable total 60.5 days and cash receipts on patient receivables have exceeded budget by \$17.7 million.
- Year to date capital expenditures of \$30.0 million were 21% under budget. Expenditures for the Ross Heart Hospital total 9.2 million year to date and are not part of the capital budget.
- Health System attained 102% productivity of its workforce through March.

Prepared by the Ohio State University Health System
April 18, 2003

SUMMARY OF BUDGETED RESOURCES AND EXPENDITURES
FY 2003 THIRD QUARTER BUDGET REPORT
(In Thousands)

	Original Budget		3rd. Quarter Budget Revision		Difference	
	General Funds	Other Funds Total	General Funds	Other Funds Total	General Funds	Other Funds Total
Resources						
State Subsidy & Appropriations	348,012	92,969 440,981	341,536	90,645 432,181	(6,476)	(2,324) (8,800) (1)
Student Fees	447,082	9,029 456,111	449,844	9,029 458,873	2,762	0 2,762 (2)
Gifts, Grants & Contracts	55,270	459,628 514,898	58,024	465,428 523,452	2,754	5,800 8,554 (3)
Health System		828,517 828,517		828,517 828,517	0	0 0
Auxiliaries		188,217 188,217		188,217 188,217	0	0 0
Other Income		96,761 119,514		96,761 119,514	0	0 0
Total Resources	873,117	1,675,121 2,548,238	872,157	1,678,597 2,550,754	(960)	3,476 2,516
Expenditures						
Education & General	872,728	645,459 1,518,187	874,892	648,935 1,523,827	2,164	3,476 5,640 (4)
Health System		831,626 831,626		831,626 831,626	0	0 0
Auxiliaries		196,539 196,539		196,539 196,539	0	0 0
Total Expenditures	872,728	1,673,624 2,546,352	874,892	1,677,100 2,551,992	2,164	3,476 5,640
Net	389	1,497 1,886	(2,735)	1,497 (1,238)	(3,124)	0 (3,124)
One Time Adjustments						
College/Offices Reallocations						
Net After Adjustment	389	1,497 1,886	(2,735)	1,497 (1,238)	5,311	2,187 2,187

- (1) General Funds: +\$2.4M in Columbus Campus State Share of Instruction over Spring Quarter estimates based on BOR figures; -\$8.9M due to the 2.5% State budget cut.
- Other Funds: -\$2.3M in restricted line items due to the 2.5% State budget cut.
- (2) General Funds: +2.8M in Columbus Campus fee income due primarily to an increase in undergraduate enrollments.
- (3) General Funds: +5.5% (\$2.8M) in indirect cost recoveries based on activity to date.
- Other Funds: + a corresponding increase (\$5.8M) in Grants and Contracts based on activity to date.
- (4) General Funds: + \$2.8M distribution of the additional indirect cost recoveries to the colleges; +\$0.5M distribution of additional fee income to the colleges; -\$1.1M in other unrestricted State line items and Regional Campus State Share of Instruction.
- Other Funds: -\$2.3M in restricted line items due to the 2.5% State budget cut; +\$5.8M in Grants and Contracts based on activity to date.
- (5) One-Time Sources: The budget shortfall will be made up by one-time sources from the colleges and support units in FY 2003 and a budget reallocation in FY 2004.

(APPENDIX LI)

PURCHASE OF REAL PROPERTY

650 ACKERMAN ROAD, COLUMBUS, OHIO

Location and Description

The property located at 650 Ackerman Road, Columbus, Ohio, is the former ABB Columbus facility, consisting of eight buildings, containing approximately 464,000 gross square feet, and situated on 26.4 acres. The property is strategically located adjacent to the Columbus Campus, at the north end of Fred Taylor Drive. The buildings were constructed between 1958 and 1974, and are in good condition. The property is owned by The Ohio State University Foundation, having been purchased from Carey Realty in January 2003.

Appraisals and Consideration

Two appraisals, one conducted in December 2002 by Ohio Real Estate Consultants and the other in March 2003 by Integra Realty Resources—Columbus valued the property at \$16,500,000 and \$17,000,000, respectively. The purchase price for the transfer of the property is approximately \$16,328,000, plus closing costs and fees. University bonds will be used to fund the purchase, with rental income cover the debt service and operating expenses for the complex.



Use of the Property

Title to the property will be taken in the name of the State of Ohio for the use of The Ohio State University. The property is being purchased to allow for expansion of the University's research, office, and laboratory space in support of the Academic Plan. There are two tenants currently leasing space in the buildings: ABB with approximately 253,000 square feet for up to three years and ACT with about 20,000 square feet for up to five years. The remaining space is immediately available for University use.

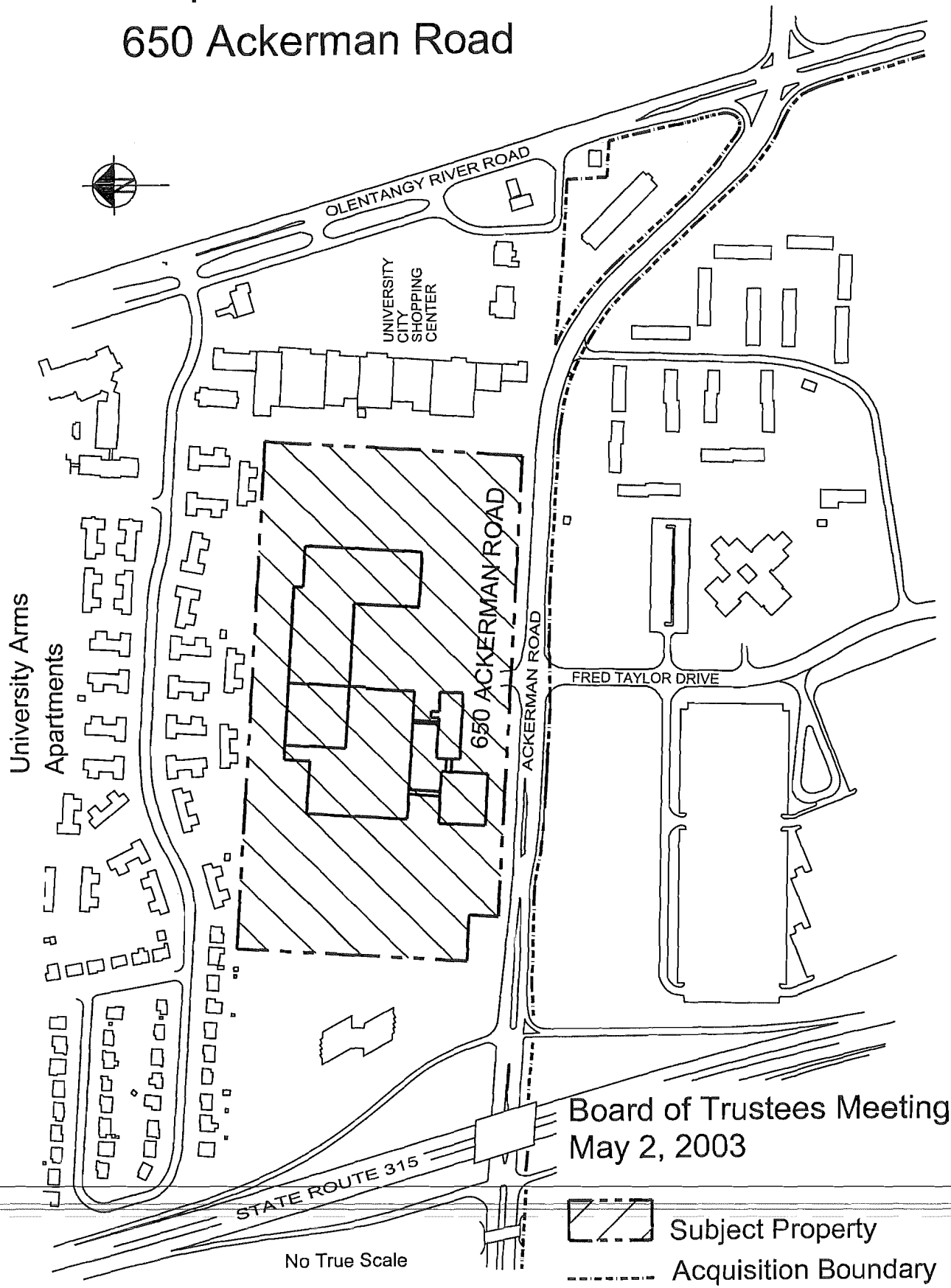
Proposed Purchase of Real Property 650 Ackerman Road



Board of Trustees Meeting
May 2, 2003

-  Subject Property
-  Acquisition Boundary

Map Provided by the Office of Facilities Planning and Development

THE OHIO STATE UNIVERSITY
OFFICIAL PROCEEDINGS OF THE
ONE THOUSAND THREE HUNDRED AND NINETY-FOURTH MEETING
OF THE BOARD OF TRUSTEES

Columbus, Ohio, May 30, 2003

The Board of Trustees met at its regular monthly meeting on Friday, May 30, 2003, at The Ohio State University Longaberger Alumni House, Columbus, Ohio, pursuant to adjournment.

**

**

**

Minutes of the last meeting were approved.

**

**

**

May 30, 2003 meeting, Board of Trustees

The Chairman, Mr. Sofia, called the meeting of the Board of Trustees to order on May 30, 2003, at 10:30 a.m. He requested the Secretary to call the roll.

Present: Zuheir Sofia, Chairman, Tami Longaberger, Daniel M. Slane, Robert M. Duncan, Karen L. Hendricks, Dimon R. McFerson, Jo Ann Davidson, Douglas G. Borrer, Walden W. O'Dell, Paula A. Habib, and Emily M. Quick.

--0--

INTRODUCTION OF NEW TRUSTEES

Mr. Sofia:

I would like to start by introducing the two newest members of the Board. Governor Taft appointed Walden W. O'Dell as a member of this Board. Wally is Chairman and CEO of Diebold, Inc. -- a leading international manufacturer of automated teller machines, voting machines, and other automated devices -- based in North Canton, Ohio.

He currently serves on the board of directors of Federal Signal Corporation, Lennox International Inc., the Columbus Association of Performing Arts, the Canton Cultural Center for the Arts, and the Ohio Foundation of Independent Colleges (OFIC). He is a member of the Ohio Business Roundtable and is a national trustee for Boys and Girls Clubs of America. He is also a member of The Ohio State University Advocates and is a lifetime member of the Alumni Association. Wally is very committed to excellence in education and is an active supporter of Ohio State.

Wally is succeeding Jim Patterson on the Board, and will serve a nine-year term that expires in 2012!

We are also pleased to welcome our new student trustee, Emily M. Quick. Emily was appointed by the Governor on Wednesday to a two-year term on the Board. Emily is from Reynoldsburg, Ohio, and is an honors business major in the Fisher College of Business. She works as a University Ambassador and as an assistant in Adapted Recreational Sports, working with students with special needs. And, if that isn't enough, she is also a member of The Best Damn Band in the Land! Emily, we are very happy to have you join the Board.

Please join me in welcoming both of our new Board members.

--0--

CHAIRMAN'S REPORT

Mr. Sofia:

As you know we had the Investiture of President Holbrook yesterday and at that time she gave a very thought provoking speech. I would also like to thank the Board Office for really working so hard and making this a wonderful event for everyone. A tremendous amount of work had been done behind the scenes and, truly, it was flawless. So, let's give them a hand; we really appreciate it.

Once again, it is an honor for me to serve as Chairman of the Board of Trustees of The Ohio State University. Ohio State is already a great university; however, our goal is to become the nation's premier teaching, learning, and research institution as set forth in the Academic Plan. We know where we are headed but to get there we have a tough road ahead. Challenges do create opportunities along the way and, in particular, during this coming year, let us keep the following observations in mind:

CHAIRMAN'S REPORT (contd)

Mr. Sofia: (contd)

First, budget crises are facing most states of our nation and Ohio is no exception. However, such crises are not going to fade away like a passing summer shower. We must continue to engage legislators in the critical importance of higher education. We must continue to mobilize our constituents: students, faculty, staff, parents, alumni, donors, current and former trustees, affiliated board members, and friends to build public support and confidence in our goals. But at the same time we must be realists. That is, we should continue to build contingency plans to deal with this tough situation. This calls for more private funding, federal grants, partnerships with businesses and state government such as Governor Taft's Third Frontier initiative, commercialization of patents, reasonable increases in tuition and fees -- and I emphasize reasonable -- and constant improvement in productivity, etc. There is no question that a model for funding of public higher education is emerging and we need to make adjustments. William Arthur Ward put it best when he said,

"The pessimist complains about the wind;
The optimist expects it to change;
The realist adjusts the sail."

And that is Ohio State. For those of us who have not seen so many articles recently about this situation from many, many prominent magazines, there is one most recently in *Business Week*, and it says here in a big headline, "Colleges in Crisis." It says, "As costs spin out of control, funding is in retreat. Bottom line: Some fundamental changes lie ahead."

Second, a great university is always benchmarking to best practices. The Ohio State University is no exception, but to get ahead and achieve premier status we must rethink in broad terms about the way we do business. We should continue to improve our business processes. There is no question that we are on the right track emphasizing efficiency and productivity and making bold moves, when appropriate versus incremental steps. We must be prepared to deal with the new reality of doing more with less. Louis Pasteur put this in perspective when he said,

"Chance favors the prepared mind" and "fortune favors the bold."

Third, we are making some tough and smart choices here at Ohio State, but going forward we may need to make more of them. We must continue to improve our top programs, which means focusing on fewer activities. As Dr. Holbrook mentioned yesterday, that has changed, and we have to live with change. In today's environment we all know we cannot do something new without eliminating something else. This is not really an option for many of us, but a strategic imperative.

Fourth, Ohio State is blessed with a very strong arts and sciences core. As you know, many of our highest ranked programs, Selective Investment faculty awards, and a large percentage of our honors program students are in the arts and sciences. The recent White Paper initiative to form a Federation of Arts and Sciences under the leadership of Executive Dean Michael Hogan is a great step in our march to be among the nation's top ten public universities. President Holbrook and Provost Ray are to be commended for spearheading this great initiative.

Fifth, we have made great strides in improving the quality of our undergraduate learning experience. We recognize a simple principle: students are our primary customers and a world-class faculty is our invaluable resource. Student learning

CHAIRMAN'S REPORT (contd)

Mr. Sofia: (contd)

comes first and we must continue to excel in undergraduate education and place more resources and effort to make it better.

Sixth, Ohio State should be a balanced teaching, learning, and research university. We are committed to The Ohio State University tradition of caring, diversity, community involvement, and outreach and engagement.

Finally, we have made great strides since Dr. Holbrook arrived to improve our research capabilities across our various academic disciplines. The recent announcement of The Wright Capital Fund Award to Ohio State by Governor Taft is an example of what we can do as a great research university. Going forward, we need not only to look for opportunities to enhance research, but we must organize for it and be ready to act on it. Research is discovery, so if we do not capitalize on success, then we have created an opening for someone else. Peter Drucker captures this critical implication when he said,

“There is no sin greater than failing to run with success.”

I know from my experience on the Board in the past, we have missed some of those opportunities that other people have taken advantage of, and I hope that will not happen again.

Ohio State is the “Flagship University” of the State of Ohio and as such we need to think more strategically about our goals and lay out a clear path for successful execution of those goals. We have a leader in President Holbrook who is committed to the highest standards of teaching, learning, and research. The bottom line: Ohio State will not be the victim of the crises facing higher education across our nation today. As Ralph Waldo Emerson said -- and really put it just right --

“This time, like all times, is a good time if we know what to do with it.”

--0--

PRESIDENT'S REPORT

President Karen A. Holbrook:

Thank you, Chairman Sofia, for your very thoughtful words. I want to join Chairman Sofia in welcoming our two new members to the Board, Wally O'Dell and Emily Quick. I, too, am delighted that you're both here and look forward to working with Wally for nine years and for two years with Emily. Welcome to both of you.

I would also like to acknowledge someone else this morning, Robert Meier, who is completing his term as chairman of the University Staff Advisory Committee. Under his leadership, USAC produced an excellent report on staff compensation and benefit issues. He has worked very hard to forge relationships, partnerships, and collaborations between USAC and other University offices, and he's been an outstanding steward of resources, Mr. Chairman, finishing his term far under budget.

Robert, thank you very much for your outstanding leadership of USAC this year and also thank you for your kind words yesterday. Would you please stand so we can recognize you? Thank you very much.

PRESIDENT'S REPORT (contd)

President Holbrook: (contd)

I spoke at the Investiture about the importance of research at Ohio State, and I want to continue that conversation this morning by focusing specifically on undergraduate research.

When I was an undergraduate, research opportunities for students were limited to research papers, to honors theses, to capstone projects, and sometimes to independent study where a student would identify a project he or she wanted to do, pick an advisor, and carry it out.

Over the past decade or more, we have seen an increased emphasis on undergraduate research. In 1996, the National Science Foundation conducted a study on undergraduate education in science, mathematics, and engineering. The report recommended that the undergraduate experience include many of the elements that are characteristic of graduate education: courses that address real problems; active learning, direct experience; increased mentoring and advising; learning through apprenticeship; primarily, an emphasis on inquiry.

Two years after the NSF study, a Carnegie Foundation report on "Reinventing Undergraduate Education" recommended that research-based learning become the standard. Thus, the boundaries between graduate and undergraduate education have been blurred with the trend toward learning-by-doing for undergraduates as well as graduate students.

What is more important is what undergraduates themselves say about a research experience. In 1999, a large group of undergraduate students representing many universities and colleges across the nation gathered in Washington, D.C. to lobby members of Congress and the President to invest more money in undergraduate research. The students argued persuasively that our economic competitiveness and the health and security of our people will depend on how wisely we invest in research and on those who will replace the current generation of scientists. In their written testimony, the students concluded:

"Each of us is convinced that because our undergraduate research experience has helped us better learn how to pose questions, gather data, make reasoned judgments, and use sophisticated technologies to answer questions of national interest, we will be better able to contribute to the work force and as citizens of the next century... We encourage Members of Congress and the White House to sustain and increase funding of programs that provide undergraduate research opportunities."

Ohio State students agree and we are doing something about this. I have heard from many of the participants in the Denman Undergraduate Research Forum that their research experience was an invaluable part of their education. And more undergraduate students are interested in research opportunities. This year, a record 228 students displayed their research projects at the Denman Forum – a 62 percent increase over the previous year.

Undergraduate research experiences prepares students for careers as well as graduate study. Employers and administrators of graduate programs understand that the benefits reach far beyond any specific research results from the students' projects. Classroom theories take on relevance and meaning through application. Students begin to build a network of research colleagues, learn how to think and analyze, to work independently, and to synthesize conclusions from a vast array of information. Research builds confidence, patience, tenacity, and endurance. It allows students to experience frustration and even failure, and

PRESIDENT'S REPORT (contd)

President Holbrook: (contd)

thus provides them with opportunities to learn lessons that one can learn only from being wrong. It forces them to confront ethical and legal concerns and perhaps most importantly, it gives them an opportunity for a taste of the excitement of discovery.

The benefits of undergraduate research also extend to faculty. It's a privilege to work with the bright students who share their interest in a field of study.

My three decades of research experience as a student and faculty member gave me the opportunity to become an expert on a topic I felt that I owned and that was a passion for me. My research connected me with a sphere of colleagues across the world who spoke the language of research and were as committed to their own areas of inquiry as I was to mine. It helped me develop a framework of critical thinking, questioning, understanding different perspectives, drawing conclusions, and communicating that not only served me well in science, but in all other roles I've taken on after leaving the laboratory.

I want to ensure that Ohio State allows every undergraduate student to become exposed to research. I will ask faculty and administrative colleagues to work with me to increase the availability of opportunity for our students to have a significant research experience during their undergraduate years. It truly personalizes an education for each student in this large university.

Thank you for allowing me to share, once again, one of my top priorities for undergraduate education at The Ohio State University.

--0--

STUDENT RECOGNITION AWARD

Ms. Habib:

The Student Recognition Award is presented each month by the Board of Trustees to a student in honor of the student's achievement in his or her area of study, service to the University and/or area or community, and/or research achievements that have been a credit to the college or the University.

This month's recipient is Chad Endsley, who was nominated by Dean Bobby Moser in the College of Food, Agricultural, and Environmental Sciences. Chad is an agribusiness and applied economics major, graduating in June, and will be entering law school here at Ohio State in the fall. He is the son of Larry and Debbie Endsley of Coshocton, Ohio. His academic advisor is Dr. Bernie Erven.

Chad has assumed a number of leadership positions during his years at Ohio State, both in his own college and across the University. He has been an active member of the Agribusiness/NAMA Club, the Saddle and Sirloin Club, the Alpha Gamma Sigma professional agricultural fraternity, and the Agriculture and Natural Resources Council, having held multiple offices and committee responsibilities.

Within the University, Chad has been an active member of the Edward S. "Beanie" Drake Student Leader Endowment Fund, most recently having served as chairman, and has volunteered with Habitat for Humanity and the Peanut Butter and Jam program, making sandwiches for area homeless. His community service record is also impressive, having participated in Adopt-A-Highway, Volunteer-A-Meal, and the Croatia Children's Orphanage projects.

STUDENT RECOGNITION AWARD (contd)

Ms. Habib: (contd)

Chad has studied abroad through the Institute for Shipboard Education/Semester at Sea, studying comparative European politics, business, world religions, art, and literature in 11 European countries. He has also studied international relations and trade between the U.S. and the European Union in Austria and Germany as a part of the International Leadership Seminar for the State FFA Officers Program.

Being a student myself, it is a great honor for me to be able to present a student like Chad to the Board of Trustees. The Board appreciates the chance to meet students, especially ones who exemplify exactly how bright and committed the students at Ohio State really are. Congratulations, Chad.

Mr. Chad A. Endsley:

Thank you, Paula, for those kind words and thank you to the Board of Trustees for this honor. As I graduate this spring and look back on my four years at Ohio State, I would like to share with you how much I've really enjoyed my experience here.

I'd also like to recognize my college, the College of Food, Agricultural, and Environmental Sciences, for their commitment to excellence; thank you Dr. Moser and thank you to other members of that college who are here this morning. I really appreciate everything – the personal touches especially. Dr. Bernie Erven has been an excellent academic advisor and I appreciate the interaction with faculty and the quality of education I've received.

Thank you, again, for this recognition.

--0--

DISTINGUISHED UNIVERSITY PROFESSOR AWARDS

Provost Edward J. Ray:

It is with great pleasure that I introduce the 2003 Distinguished University Professors. Before we begin, however, I would like to thank the Selection Committee and ask any members who are present to please stand and be recognized.

The designation of Distinguished University Professor is the highest honor bestowed on senior faculty members at The Ohio State University. The honor is so selective that to date only 26 faculty have received this award. In addition to the permanent honorific title, recipients receive an award of \$10,000 for three consecutive years from the Office of Academic Affairs to support their scholarly endeavors.

The first recipient is Kevin R. Cox, from the Department of Geography. Professor Cox received his bachelor's degree from Cambridge University, and master and doctorate degrees from the University of Illinois. He joined Ohio State's faculty in the Department of Geography in 1965. Colleagues credit him as being pivotal to the department's rise to one of the top five departments of geography in the United States.

Professor Cox is an internationally recognized scholar in three distinct areas: the geography of voting, behavioral geography, and the politics of urbanization and

DISTINGUISHED UNIVERSITY PROFESSOR AWARDS (contd)

Provost Ray: (contd)

local-global influences. In his nomination letter, Randall B. Ripley, dean of the College of Social and Behavioral Sciences wrote,

“These topics are of enormous importance in a world that is increasingly democratized, influenced by perception as much as actuality, urbanized, and broadly affected by forces of globalization.”

Nominators in the Department of Geography wrote,

“Cox’s record epitomizes the scholar-teacher ideal to which we all aspire.”

For example, under his leadership the undergraduate curriculum was revised, new courses were added, and student services were revitalized. In addition, he has received prestigious recognitions including the Guggenheim Fellowship, the Honors Award of the Association of American Geographers, and Ohio State’s Distinguished Scholar Award.

Professor Cox, please come forward. [Plaque and medallion presented to Professor Cox.]

Our next recipient is Eric Herbst, professor in the Departments of Physics, Astronomy, and Chemistry. Professor Herbst received his A.B. degree in chemistry from the University of Rochester, and his master and doctorate degrees from Harvard University. He joined Ohio State’s faculty in 1991.

Professor Herbst is internationally regarded as a pioneer and one of the leading researchers in the field of molecular astrophysics in the world. In 1973, he and William Klemperer wrote “The Formation and Depletion of Molecules in Dense Interstellar Clouds,” a seminal paper about which his nominators wrote,

“This paper literally started the field of molecular astronomy.”

To date, he has more than 240 papers published in peer-reviewed journals. Alexander Dalgarno, Phillips Professor of Astronomy at Harvard University, wrote that Professor Herbst’s papers,

“All have something unique to say and are mandatory reading for entering graduate students and seasoned practitioners alike.”

His research has spanned across physics, astronomy, and chemistry, and during the course of his career, he has taught basic and advanced courses in the three departments. Among his many awards, Professor Herbst has been recognized with the Alfred Sloan Foundation Award, the Max Planck Research Prize, Ohio State’s Distinguished Scholar Award, and twice with awards for graduate teaching.

Professor Herbst, would you please come forward? [Plaque and medallion presented to Professor Herbst.]

Our final recipient for 2003 is Brian D. Joseph. Professor Joseph earned his A.B. degree from Yale University and his master and doctorate degrees in linguistics from Harvard University. He joined Ohio State’s faculty in the Department of Linguistics in 1979 and received a joint appointment in the Department of Slavic

DISTINGUISHED UNIVERSITY PROFESSOR AWARDS (contd)

Provost Ray: (contd)

and East European Languages and Literatures in 1997, where he holds The Kenneth E. Naylor Professorship.

In his nomination letter, Dean Michael J. Hogan, College of Humanities, wrote,

“Joseph is considered the leading scholar in Greek linguistics today, but he is also an internationally recognized scholar in the field of Balkan linguistics.”

Hogan also wrote,

“He was chair of Linguistics from 1987 to 1997, presiding over a department that rose during that decade to eighth among this nation’s programs in linguistics in the National Research Council ratings.”

He has taught virtually every course in the Department of Linguistics. In addition, he is the recipient of the Alumni Award for Distinguished Teaching, the Distinguished Scholar Award, and the Faculty Award for Distinguished University Service. We refer to this as “the Triple Crown,” reflecting the University’s tripartite mission. Professor Joseph is only the second faculty member ever to achieve that distinction.

Professor Joseph, would you please come forward? [Plaque and medallion presented to Professor Joseph.]

Mr. Chairman, I’d like to invite each of our Distinguished University Professor Award winners to make a few comments, and then offer the Board an opportunity to ask any questions they might have.

Professor Kevin R. Cox:

Mr. Chairman and members of the Board of Trustees, it seems as if I’ve been a geographer forever. I was born in a very small village in the middle of England. Household circumstances were quite modest, but there was a certain amount of very short distance travel. Nevertheless, it included different parts of the same county and there’s a lot of variation in Warwickshire. It also included visits to the area that my mother came from, which was a coal mining area. So from a very early age, I had this sense of difference.

Then, later on, I began to realize that these places were connected in various ways to one another. I remember going with my father to see the coal being loaded on boats, which would then take it down to London. I began to realize then that without London, there would be no coal field; without a coal field, there would be no mother; without a mother, there would be no me. So there you have it in all its simplicity -- not quite what I intended -- the two major themes of contemporary geography: difference and connection. Everything else is a variation on those two things: differences in interpretation, differences in method, and differences in substance.

My own substance is the politics of local and regional development: how localities develop, how they underdevelop, how they de-develop, and how in some cases you have disinvestments in others, investment, how there is variation between suburbs and the way in which politics makes a difference today, not just the matter of rezoning disputes and conflicts over annexation, but altogether deeper forces.

DISTINGUISHED UNIVERSITY PROFESSOR AWARDS (contd)

Provost Cox: (contd)

As you can tell, I am deeply committed to my field. I identify strongly with it. So this recognition is also recognition of the field of geography. It is also recognition of the Department of Geography and my college, to both of which I am deeply indebted.

The Department of Geography at The Ohio State University is one of which you can all be rightly proud. For many years now, it has been one of the preeminent departments, not just in the country, but in the world. We are, in fact, fourth in this country and we have a great deal of international visibility with internationally known scholars.

But, of course, without the support of the college, geography would have been lost, or it certainly would not have done as well as it has, without the sort of support that we have received. So it is also an honor to my department, it is an honor to my college, and to the respective leaderships of the department and the college – Larry Brown and Randall Riply, the person we know affectionately as “Rip.” Without them, I doubt that I would be here today. Thank you.

Professor Eric Herbst:

Thank you very much for letting me address you. My research, as you heard from Ed Ray, is called astrophysical chemistry, and it concerns the formation of molecules everywhere in the universe. I am especially interested in objects called interstellar clouds. These are giant accumulations of gas and dust that exist among stars in our galaxy and, indeed, most others.

One of the things that is interesting about these objects is they're factories where molecules are created from simple atoms under conditions that are very, very different from those on our planet. Not surprisingly, many of the molecules that are found in interstellar clouds are quite bizarre by terrestrial standards.

With my coworkers and students, we have discovered the types of chemical processes that form molecules from atoms in interstellar clouds and other objects. Then we've used this knowledge with the help of the Ohio Supercomputer Center to make giant computer simulations of the chemistry that occurs in these regions. Our simulations allow us to predict the concentrations of molecules in clouds and to predict how large these molecules can become. Moreover, they tell us a lot about the physical conditions in clouds.

Now you might think all of this is very esoteric, but the Earth is a very puny, insignificant part of the universe and my interstellar clouds are located everywhere. As I tell chemists, the chemistry of interstellar clouds is clearly more important than the chemistry on Earth. But moreover, interstellar clouds are important because they collapse to form stars and planetary systems. About 5 billion years ago, give or take a few hundred million years, a local interstellar cloud collapsed to form our sun and solar system. So the molecules on Earth, indeed the molecules in this room, the molecules in your very bodies, have some complex relationship to the molecules that existed in the interstellar cloud that existed before all of us.

One of the things we're doing presently is trying to understand this relationship and to understand what happens to molecules as clouds collapse to form planetary systems. Thank you.

DISTINGUISHED UNIVERSITY PROFESSOR AWARDS (contd)

Professor Brian D. Joseph:

Chairman Sofia, Dr. Holbrook, and assembled guests and members of the Board of Trustees, I'm a linguist. I'm therefore interested in language. That is Language with a capital "L," Language as a human phenomenon, Language as a social system, and Language as a cognitive system. Within that area, my specific interests are in language change, what we call historical linguistics -- how languages change and develop over time.

My main focus within that area of specialization is Greek and the languages closely related to Greek, both as members of the same family like Latin and Sanskrit, German, even English, but also as members of the same geographic area. That's where my interest in the Balkans comes from -- the south Slavic languages: Albanian, Romanian, Turkish, and others. By understanding the details of the development of Greek and these other languages, I have tried over the years to contribute to a general understanding of the way languages change, not just specific languages, but language more generally.

Language is both a social and psychological phenomenon. On the one hand, linguistics is a social science, but at the same time a humanistic endeavor as well. Therefore, to understand language change I've had to look not only to psychological issues such as learnability and perception -- especially the perceptions of similarities among different parts of a language system -- but also to social factors.

Why is all of this important? Language is one aspect that reveals our humanity and has been said to be the main thing that differentiates us from other animals and marks us as humans. Yet, interestingly it's not stable. Some human institutions change and some remain the same over time. So why is it that language is one that changes and how is it that language can change and yet still preserve its functionality from generation to generation?

That is the issue that I look at. I have not yet come up with all the answers, but I'm still working on it. I'm proud to sit here before you as both a linguist, but also a humanist representing the humanities in this august group of OSU's faculty. Thank you.

Mr. Sofia:

We just heard some outstanding presentations and accomplishments from Professors Cox, Herbst, and Joseph. We even learned something new about those top rankings, which are exceptional here. So we truly are blessed to have such distinguished faculty who achieve so much at this wonderful University. We won't let you get off this easy, we have some questions to ask you.

Who is going to start first? Dimon --

Mr. McFerson:

As an accountant, I don't understand what you are all talking about, but I'm enormously proud that you're affiliated with The Ohio State University. To Drs. Cox and Joseph, I would ask do we still have increasingly interested students engaged in geography and language? Or are there trend lines here that are focusing students in different directions than your chosen fields?

DISTINGUISHED UNIVERSITY PROFESSOR AWARDS (contd)

Professor Cox:

I think one thing you could look at is the number of undergraduate majors that we have in geography, which has gone up quite remarkably over the last decade -- we're now at about 250 students. Less than 10 years ago, the number of undergraduate majors would have been 70 or something like that. So this is quite a significant development.

One thing that perhaps would be of interest is the increasing awareness of the societal applicability of what students learn in geography, so this might be of interest to the Board. I won't mention figures, but our students are getting extremely good jobs in terms of salary. So this is something that is clearly in demand and we're proud of that as well.

Geography is a very exciting field. It's extremely diverse. We have both physical and human geographers, so we are as interested in processes of globalization as we are in things like climatic change. In fact, we do have people in the department who are actually engaged on ice caps, unfortunately, studying climatic change.

Mr. Sofia:

This is great. You know, if it was up to me, Dr. Holbrook, I'd make it a required course. Many of us here in the United States don't know a lot about geography.

Mr. McFerson:

Let me ask Dr. Joseph to respond as well.

Professor Joseph:

Sure. The study of specific languages at Ohio State is very robust, with some 30 or so different languages taught throughout the College of Humanities. I myself teach a somewhat esoteric language, Sanskrit, but I have had some 20 students every time I offer the course.

With regard to the study of linguistics -- that is Language with a capital "L," as opposed to particular languages -- like Professor Cox, I can point to increases in the number of undergraduate majors in my department, also in the Slavic department. And in linguistics we have a large number of graduate applicants every year -- some 120 students applying for roughly 10 positions that we can take -- and that is an index of the level of interest in the field in general.

Mr. McFerson:

Good. Thank you very much.

Mr. Sofia:

Professor Herbst, I would like to ask a question. What two or three things do you think make you excel so much in your field?

Professor Herbst:

That's a hard question to answer. I think what happened is when I was a graduate student in chemistry I really hadn't thought about doing anything else. At that time, astronomers were first starting to observe molecules in interstellar

DISTINGUISHED UNIVERSITY PROFESSOR AWARDS (contd)

Professor Herbst: (contd)

space. They didn't quite know what to do with them, because they weren't trained in chemistry. So it seemed a very natural thing to do.

How I got into a physics department is a little more complicated. My first academic position was at the College of William and Mary in Virginia, where I was a chemist. Then there was a vacancy in the physics department at Duke University, which is where I went next. The person who was retiring was actually doing very similar work to what I was doing in chemistry, so that is how I changed.

I was rather tense at first about having to teach physics, worrying that the people would always call me a chemist and not allow me to teach. Actually the opposite happened – they forgot about my background and wanted me to teach every type of graduate course in physics. It was difficult, but I did do it. It is just varied experiences that led to this very interdisciplinary work.

Mr. Sofia:

That's truly fascinating. Other questions? Speaker Davidson --

Ms. Davidson:

I think it would be a shame if we let the three of them leave without asking them for any comments that they might have. This morning you heard in Chairman Sofia's and President Holbrook's comments about our continuing strive to increase the excellence at Ohio State. I think we all know that you three are the examples of what we need and have to help us increase that excellence at Ohio State. But do you have any other ideas, suggestions, and/or thoughts that you might have that would help the Board of Trustees in our leadership? This is a great opportunity. We just want to open the door for you to make those comments.

Professor Joseph:

I think all of the initiatives that we've heard about: the coalescence of the arts and sciences to foster greater cooperation amongst the colleges is, in my mind, a step in the right direction. I see us as being all on the same team, as it were, and I hope it will allow us to work more smoothly in the development of courses and cross-departmental appointments and the like.

I'd like to echo President Holbrook's interest in undergraduate research. We try very hard to get our students involved in projects – learning by doing, rather than just by absorbing. I think that's certainly the wave of the future and the crest that we'll ride to excellence.

Professor Cox:

Obviously the question is very difficult, but in my experience -- and obviously it's quite a long experience, since I've been here since 1965 – leadership is tremendously important. Not somebody who merely has the administrative skills, but somebody who – and it is a rare combination -- knows what is happening in a particular discipline, or in the case of a dean, who has a sense of what is going on in a particular cluster of subjects. It's very, very difficult to find the right people. When you do, then the progress is tremendous.

DISTINGUISHED UNIVERSITY PROFESSOR AWARDS (contd)

Professor Cox: (contd)

So finding leadership is a major part of the answer in terms of making this a superior school. I would say that in social and behavioral sciences, I think we've been blessed and certainly geography has been blessed in that regard.

Mr. Sofia:

Thank you. Professor Herbst --

Professor Herbst:

I think I would second these remarks. The two departments that I've been a member of -- chemistry just recently -- astronomy and physics, have both been getting much better in recent years, certainly in rankings and the people coming to them. I think that's due to the leadership in both departments.

If there's something I've noticed here that is a little bit of a weakness compared with other places I've been, it's not in the hiring of good people. I think we uniformly hire very good people. It's perhaps making sure that these people keep on a track that is as distinguished as they had before they came. So I would think something that has been done to some extent in physics is to try to nurture people, even five to 10 years after they've come here, to make sure they keep going and keep getting better.

There are a lot of things we have to do as professors. We have a lot of service requirements, which we enjoy and that's important, and teaching is certainly important, but finding time for research in all of this can get more and more difficult. I think in the median years it's something that one has to try to look at very carefully. So that's a modest suggestion.

Mr. Sofia:

Professor Herbst, you were at two distinguished universities before coming to Ohio State. How do you compare the quality and ability to learn of our students to the places you taught before?

Professor Herbst:

On a graduate and undergraduate level, Ohio State is the best place I've taught. It's not even close. I was surprised when I came that I found the undergraduates in physics so very good. The numbers are not large compared to geography, but the number of people has been increasing. At the top, I think the students are much better than the students I had at Duke. Now it's hard to compare, because at William and Mary I was in chemistry. The graduate students are quite excellent here, too.

Mr. Sofia:

Other questions? Again, we are truly honored to have you here this morning. We are proud to have such distinguished professors at The Ohio State University, and hope you'll be successful in the years ahead.

--0--

CONSENT AGENDA

President Karen A. Holbrook:

We have seventeen resolutions on the Consent Agenda today and I would like to ask that #13 – the Authorization, Issuance and Sale of General Receipts Commercial Paper Notes, Series E, of The Ohio State University – be considered separately. We are seeking your approval for the following:

APPOINTMENTS/REAPPOINTMENTS TO BOARDS

Resolution No. 2003-128

Synopsis: Approval of appointments/reappointments of Board members is proposed.

WHEREAS the Board of Trustees on November 30, 1979, approved the establishment of a University Hospitals Board, and on December 6, 2001, approved the establishment of a University Hospitals Board East, and OSU & Harding Hospital Board; and

WHEREAS the membership of the Hospitals Board was approved on April 4, 1980, and has been subsequently amended; and

NOW THEREFORE

BE IT RESOLVED, That the following individuals be appointed/reappointed as citizen members of the Boards for the terms May 1, 2003, through April 30, 2006:

University Hospitals Board

John G. Kramer (3rd reappointment)
Richard Murphey, Jr.* (3rd reappointment)

University Hospitals Board East

Joyce Estes (2nd reappointment)
Theodore Fredrickson
Frederick L. Ransier
Grayce M. Sills

OSU & Harding Behavioral Health and Medicine Board

Lee Shackelford Szykowney

*Appointed as Chairman of University Hospitals Board

**AMENDMENTS TO THE *BYLAWS OF THE MEDICAL STAFF OF*
THE OHIO STATE UNIVERSITY HOSPITALS**

Resolution No. 2003-129

Synopsis: The amendments to the *Bylaws of the Medical Staff* of The Ohio State University Hospitals are recommended for approval.

AMENDMENTS TO THE *BYLAWS OF THE MEDICAL STAFF OF THE OHIO STATE UNIVERSITY HOSPITALS* (contd)

WHEREAS The Ohio State University Hospitals Board pursuant to bylaw 3335-101-04 of the Hospitals Board Bylaws is authorized to recommend to the Board of Trustees the adoption of amendments to the *Bylaws of the Medical Staff* of The Ohio State University Hospitals; and

WHEREAS the proposed amendments to the *Bylaws of the Medical Staff* of The Ohio State University Hospitals were approved by the University Hospitals Board on April 24, 2003:

Amended Bylaws

3335-43-04 Membership.

(A) through (B) unchanged.

(C) Terms of appointment. Initial appointment to the medical staff shall be for a period extending to the end of the fiscal year (first of July through thirtieth of June) or following fiscal year depending upon date on which applicant first becomes eligible for reappointment, not to exceed twenty-four months. Reappointment to the medical staff shall be done on a regular basis for a period not to exceed twenty-four months. Initial appointment, except appointment to the honorary medical or limited staff categories, shall be provisional for six months regardless of the date of the appointment. During the period of the provisional appointment all applicants shall be subject to continuous review and reconsideration pursuant to these bylaws. ~~Following the six month period if no adverse action has been taken the appointment shall no longer be provisional. Full appointment requires the evaluation of the department chair. If, after the six-month period, the department chair does not recommend the provisional appointee for full appointment, medical staff membership and clinical privileges may be terminated. In the event that an adverse action is taken against a provisional appointee, the provisional appointee shall be entitled to the provisions of due process as outlined in these bylaws.~~

Balance unchanged.

3335-43-07 Categories of the medical staff.

The medical staff of the Ohio state university hospitals shall be divided into four categories: honorary medical staff; attending medical staff; courtesy medical staff; and limited staff.

(A) through (C) unchanged.

(D) Limited staff.

Limited staff are not considered full members of the medical staff, do not have delineated clinical privileges and do not have the right to vote in general medical staff elections. Except where expressly stated, members of the limited staff are bound by the terms of these bylaws, the rules and regulations of the medical staff, and the limited staff agreement.

(1) Qualifications:

(a) and (b) unchanged.

(c) Members of the limited staff shall possess a valid training certificate or an unrestricted Ohio license from the applicable state board based on eligibility criteria defined by that state board. All members of the limited staff shall be required to successfully obtain an Ohio training certificate prior to beginning training within a program. ~~Also, members of the limited staff, except dentists, shall make written application for an Ohio license no later than one year after becoming eligible for an Ohio license and must thereafter obtain and maintain licensure in Ohio during the term of the limited staff member's post-doctoral education.~~

**AMENDMENTS TO THE *BYLAWS OF THE MEDICAL STAFF OF
THE OHIO STATE UNIVERSITY HOSPITALS (contd)***

Amended Bylaws (contd)

Balance unchanged.

3335-43-09 Elected officers of the medical staff of the Ohio state university hospitals.

(A) through (F) unchanged.

(G) Term of office.

- (1) The chief of staff and chief of staff-elect shall each serve two years in office beginning on July first. ~~The chief of staff shall be elected in even numbered years.~~ The chief of staff-elect shall be elected in the odd numbered years. A former chief of staff may not succeed the immediately preceding chief of staff-elect.

Balance unchanged.

3335-43-10 Administration of the medical staff of the Ohio state university hospitals.

(A) through (C) unchanged.

(D) ~~Credentials~~ Health system credentialing committee:

(1) Composition:

~~The committee shall consist of eleven members of the medical staff. Appointments to the committee shall be in accordance with paragraph (B) of this rule. The chairperson of the committee shall be appointed jointly by the medical director and the chief of staff. The credentialing responsibilities of medical staff are delegated to the Ohio state university health system credentialing committee, the composition of which shall include representation from the medical staff of each health system hospital.~~

The health system credentialing committee shall be appointed by the chief medical officer of the health system. The chief of staff and director of medical affairs or medical director of each health system hospital shall make recommendations to the chief medical officer for representation on the health system credentialing committee.

The health system credentialing committee shall meet at the call of its chair, who shall be appointed by the chief medical officer of the health system.

(2) Duties:

(a) ~~To receive, through the office of the medical director, all applications for medical staff and licensed health care professional appointment and reappointment, following recommendation of the chief of the clinical department and receive all requests for delineation, renewal, or amendment of clinical privileges;~~

~~(b)~~(a) To review all applications for medical staff and licensed health care professional appointment and reappointment, as well as all requests for delineation, renewal, or amendment of clinical privileges in the manner provided in these medical staff bylaws, including applicable time limits;

~~(c)~~(b) To review biennially all applications for reappointment or renewal of clinical privileges;

~~(d)~~(c) To review all requests for changes in medical staff membership ~~or clinical privileges;~~

AMENDMENTS TO THE *BYLAWS OF THE MEDICAL STAFF OF THE OHIO STATE UNIVERSITY HOSPITALS* (contd)

Amended Bylaws (contd)

- ~~(e)~~(d) To assure, through the chairperson of the committee, that all records of peer review activity taken by the committee, including committee minutes, are maintained in the strictest of confidence in accordance with the laws of the state of Ohio. The committee may conduct investigations and interview applicants as needed to discharge its duties. The committee may refer issues and receive issues as appropriate from other medical staff committees;
- ~~(f)~~(e) To make recommendations to the medical staff administrative committee through the medical director regarding appointment applications and initial requests for clinical privileges. Such recommendations shall include the name, status, department (division), medical school and year of graduation, residency and fellowships, medical-related employment since graduation, board certification and recertification, licensure status as well as all other relevant information concerning the applicant's current competence, experience, qualifications, and ability to perform the clinical privileges requested;
- ~~(g)~~(f) To recommend to the medical staff administrative committee that certain applications for appointment be reviewed in executive session;
- ~~(h)~~(g) To make recommendations ~~The committee, after review and investigation, may make recommendations of matters related to its responsibilities, regarding the restriction or limitation of a member's clinical privileges for noncompliance with the credentialing process to the medical director, chief of staff, or the chief of a clinical department, regarding the restriction or limitation of a member's clinical privileges for noncompliance or any other matter related to its responsibilities;~~
- ~~(i)~~(h) To review all grants of special or temporary privileges; and
- ~~(j)~~(i) To review requests made for clinical privileges by other licensed health care professionals as set forth in ~~paragraph (F)(6) of rule 3335-43-07 of the Administrative Code~~ these rules.

NOW THEREFORE

BE IT RESOLVED, That the foregoing amendments to the *Bylaws of the Medical Staff* of The Ohio State University Hospitals be adopted as recommended and approved April 24, 2003, by the University Hospitals Board.

REGIONAL CAMPUS BOARDS APPOINTMENTS

Resolution No. 2003-130

Synopsis: Approval of appointments to The Ohio State University Regional Campus Boards is proposed.

WHEREAS the Board of Trustees in 1994 approved the establishment of The Ohio State University Regional Campus Boards; and

WHEREAS it has been previously stipulated that "the board shall be composed of eleven members appointed by The Ohio State University Board of Trustees in consultation with the president of the university;" and

REGIONAL CAMPUS BOARDS APPOINTMENTS (contd)

WHEREAS the following named persons have been nominated and selected for appointments to the following Regional Campus Boards for the terms as specified:

Lima Board Appointment

Walter L. Kinsey, 3-year term

Marion Board Appointments

Ronald D. Cramer, 3-year term

Aaron Fritz, 3-year term

Lynn Garvin, 3-year term

Anna Michelle Becker, 1-year term (student appointment)

NOW THEREFORE

BE IT RESOLVED, That the foregoing nominees be approved as members of The Ohio State University-Lima Board and Marion Board, effective July 1, 2003.

ACCEPTANCE OF THE WHITE PAPER ON THE FEDERATION OF THE COLLEGES OF THE ARTS AND SCIENCES AND ITS RECOMMENDATIONS

Resolution No. 2003-131

Synopsis: Acceptance of the White Paper on the Federation of the Colleges of the Arts and Sciences is proposed.

WHEREAS the five Colleges of the Arts and Sciences are a core element in the mission of the University and are integral to all parts of the Academic Plan; and

WHEREAS the University's Executive Vice President and Provost in February, 2002, established an ad-hoc committee to provide specific recommendations for strengthening the arts and sciences; and

WHEREAS the ad-hoc committee completed a comprehensive study of the Academic Plan, reviewed the organizational structure of benchmark institutions, met with the deans of each of the arts and sciences colleges, interviewed administrators at other universities, and reviewed an analysis of the arts and science colleges' office administrative structures compared to those of the benchmarks and CIC institutions; and

WHEREAS the ad-hoc committee focused its recommendations on an optimal configuration and the authority of the Executive Dean of the Arts and Sciences; and

WHEREAS the ad-hoc committee's report was submitted to appropriate University Senate committees and the faculty and staff in the arts and sciences, and the Provost and members of the committee met with numerous groups and held two open forums for the arts and sciences faculty and staff; the Provost proposed a plan to the University Senate that included consideration of the discussions and written recommendations that had been received; discussions were held in the University Senate Steering Committee, Fiscal Committee, Rules Committee, and the Faculty Council, two discussion panels were held at the University Senate meetings and additional comments were received following these meetings; and

WHEREAS the President and Executive Vice President and Provost, on May 8, 2003, disseminated a White Paper on the Federation of the Colleges of the Arts and Sciences setting forth the background, discussing the rationale and goals for the federation, delineating roles and

ACCEPTANCE OF THE WHITE PAPER ON THE FEDERATION OF THE COLLEGES OF THE ARTS AND SCIENCES AND ITS RECOMMENDATIONS (contd)

responsibilities for the executive dean and the college deans and outlining financial arrangements:

NOW THEREFORE

BE IT RESOLVED, That the Board of Trustees accept the White Paper on the Federation of the Colleges of the Arts and Sciences and its recommendations for implementation; and

BE IT FURTHER RESOLVED, That the Secretary of the Board of Trustees is hereby authorized and directed to incorporate this change in the applicable sections of the *Bylaws of the Board of Trustees*.

(See Appendix LL for background information, page 1189.)

NAMING OF BUILDING

Resolution No. 2003-132

Synopsis: The naming of the new Mechanical Engineering Building, which is to be constructed on the site of the current Robinson Laboratory located at 206 West 18th Avenue on the Columbus Campus, is proposed.

WHEREAS Peter and Clara Scott of Lake Toxaway, North Carolina, are alumni of The Ohio State University; and

WHEREAS the couple have a long and generous history of supporting their alma mater through gifts to the College of Engineering and in volunteering their time in service to Ohio State; and

WHEREAS Peter Scott's distinguished business career led him from engineering design to entrepreneurship to corporate leader to retirement and back to engineering firms and corporate board rooms; and

WHEREAS Peter Scott has received the College of Engineering's Distinguished Alumni Award and an honorary degree from The Ohio State University for exemplary business acumen:

NOW THEREFORE

BE IT RESOLVED, That in accordance with paragraph (F) of rule 3335-1-08 of the Administrative Code the aforementioned new facility shall be named the "Peter L. and Clara M. Scott Laboratory."

NAMING OF BUILDING

Resolution No. 2003-133

Synopsis: The naming of the new Competitive Aquatics Pavilion of the Recreation and Physical Activity Center, which is to be constructed as part of the Larkins Hall Replacement Project on the site of the current Larkins Hall, located at 337 West 17th Avenue on the Columbus Campus, is proposed.

NAMING OF BUILDING (contd)

WHEREAS William R. McCorkle, Jr., of Columbus, Ohio, is an alumnus of The Ohio State University, and, along with his wife of fifty-four years, Mae, has owned and operated McCorkle Inc., Realtors; and

WHEREAS the McCorkle family has a long history of friendship and support of the Ohio State swimming program through William McCorkle, Sr.'s friendship with Coach Mike Peppe; and

WHEREAS the McCorkles' distinguished business careers allowed them to provide quality and affordable housing to thousands of Central Ohio residents and earned them recognition by the National Association of Realtors, the Ohio Association of Realtors, and the Columbus Board of Realtors; and

WHEREAS Bill McCorkle distinguished himself in the service of his country as a member of the United States Navy in World War II; and

WHEREAS Bill and Mae McCorkle have been members of numerous volunteer and corporate boards, and have provided service to the community through their donations of land for city parks and their sponsorship of the "Swimming for Diabetes" events held at thirty local schools:

NOW THEREFORE

BE IT RESOLVED, That in accordance with paragraph (F) of rule 3335-1-08 of the Administrative Code the aforementioned new facility shall be named the "Bill and Mae McCorkle Aquatics Pavilion."

HONORARY DEGREES

Resolution No. 2003-134

Synopsis: The awarding of honorary degrees is recommended for approval.

WHEREAS the Committee on Honorary Degrees and the University Senate, pursuant to rule 3335-5-488 of the Administrative Code, have approved for recommendation to the Board of Trustees awarding of honorary degrees as listed below:

David Harvey	Doctor of Science
Nathaniel R. Jones	Doctor of Laws

NOW THEREFORE

BE IT RESOLVED, That the above honorary degrees be awarded in accordance with the recommendation at a time convenient to the University and the recipients.

DEGREES AND CERTIFICATES - SPRING QUARTER COMMENCEMENT

Resolution No. 2003-135

Synopsis: Approval of Degrees and Certificates for Spring Quarter is proposed.

WHEREAS pursuant to paragraph (E) of rule 3335-1-06 of the Administrative Code, the Board has authority for the issuance of degrees and certificates; and

DEGREES AND CERTIFICATES - SPRING QUARTER COMMENCEMENT (contd)

WHEREAS the faculties of the colleges and schools shall transmit, in accordance with rule 3335-9-29 of the Administrative Code, for approval by the Board of Trustees the names of persons who have completed degree and certificate requirements:

NOW THEREFORE

BE IT RESOLVED, That the degrees and certificates be conferred on June 13, 2003, to those persons who have completed the requirements for their respective degrees and certificates and are recommended by the colleges and schools, and that the names of those persons awarded degrees and certificates be included in the minutes of this meeting.

PERSONNEL ACTIONS

Resolution No. 2003-136

BE IT RESOLVED, That the personnel actions as recorded in the Personnel Budget Records of the University since the May 2, 2003 meeting of the Board, including the following Appointments/Reappointments, Appointment/Reappointments of Chairpersons and Director, Leaves of Absence Without Salary, Professional Improvement Leaves, and Emeritus Titles as detailed in the University Budget be approved; and

BE IT FURTHER RESOLVED, That the Medical Staff Appointments/Reappointments approved May 2, 2003, by The James Cancer Hospital Board, be ratified.

Appointments

Name: MICHAEL G. BEVIS
Title: Professor (The Ohio Eminent Scholar in Geodynamics)
Department: Civil and Environmental Engineering and Geodetic Science
Effective: October 1, 2003
Present Position: Professor, Hawaii Institute of Geophysics and Planetology, University of Hawaii, Honolulu, HI

Name: KEVIN R. COX
Title: Distinguished University Professor
Department: Geography
Effective: May 30, 2003

Name: ERIC HERBST
Title: Distinguished University Professor
Department: Physics
Effective: May 30, 2003

Name: MICHAEL J. HOGAN
Title: Executive Dean of the Arts and Sciences
Office: Executive Dean of the Colleges of the Arts and Sciences
Term: July 1, 2003, through June 30, 2008
Present Position: Dean, College of Humanities, and Executive Dean, Colleges of the Arts and Sciences

Name: BRIAN D. JOSEPH
Title: Distinguished University Professor
Departments: Linguistics and Slavic and East European Languages and Literatures
Effective: May 30, 2003

PERSONNEL ACTIONS (contd)

Appointments (contd)

Name: G. ANDREW KAROLYI
Title: Professor (The Charles R. Webb Designated Professorship in Finance)
College: The Max M. Fisher College of Business
Term: October 1, 2003, through September 30, 2008

Name: GAIL B. MARSH
Titles: Chief Strategy Officer and Associate Vice President
Center/Office: Medical Center/Health Sciences
Effective: April 1, 2003

Name: WILLIAM L. MACDONALD
Title: Academic Dean
Regional Campus: The Ohio State University-Newark
Term: July 1, 2003, through June 30, 2008
Present Position: Interim Academic Dean, The Ohio State University-Newark

Name: WILLIAM S. PEASE
Title: Associate Professor (The Dr. Ernest W. Johnson Professorship)
College: Medicine and Public Health
Term: June 1, 2003, through June 30, 2007

Name: GREGORY S. ROSE
Title: Interim Dean and Director
Regional Campus: The Ohio State University-Marion
Term: July 1, 2003, through June 30, 2004
Present Position: Associate Dean, The Ohio State University-Marion and Associate Professor, Department of Geography

Name: FRANKLIN B. WALTER
Title: Professor and Superintendent in Residence (The William Ray and Marie Adamson Flesher Professorship in Educational Administration)
College: Education
Term: July 1, 2003, through June 30, 2008

Name: PAUL A. WEBER
Title: Associate Vice President for Health Sciences Education and Vice Dean for Education
Office/College: Health Sciences/Medicine and Public Health
Effective: June 1, 2003
Concurrent Appointment: Chairperson and Professor, Department of Ophthalmology

Reappointments

Name: PHILIP F. BINKLEY
Title: Professor (The James Hay and Ruth Jansson Wilson Professorship in Cardiology)
College: Medicine and Public Health
Term: July 1, 2003, through June 30, 2007

Name: JACK A. BOULANT
Title: Professor (Fred A. Hitchcock Professorship in Environmental Physiology)
College: Medicine and Public Health
Term: July 1, 2003, through June 30, 2007

PERSONNEL ACTIONS (contd)

Reappointments (contd)

Name: SAMUEL CATALAND
Title: Professor (The Ralph W. Kurtz Chair in Hormonology)
College: Medicine and Public Health
Term: July 1, 2003, through June 30, 2007

Name: W. JAMES HARPER
Title: Professor (The J. T. "Stubby" Parker Chair in Dairy Foods)
College: Food, Agricultural and Environmental Sciences
Term: October 1, 2002, through September 30, 2004

Name: JAY D. IAMS
Title: Professor (The Frederick P. Zuspan, M.D. Chair in Obstetrics and Gynecology)
College: Medicine and Public Health
Term: July 1, 2003, through June 30, 2007

Name: PHILIP R. JOHNSON
Title: Professor (The Henry G. Cramblett Chair in Medicine)
College: Medicine and Public Health
Term: July 1, 2003, through June 30, 2007

Name: CARL V. LEIER
Title: Professor (The James W. Overstreet Chair in Cardiology)
College: Medicine and Public Health
Term: July 1, 2003, through June 30, 2007

Name: W. JERRY MYSIW
Title: Associate Professor (The Bert C. Wiley, M.D., Endowed Professorship in Physical Medicine and Rehabilitation)
College: Medicine and Public Health
Term: July 1, 2003, through June 30, 2007

Name: WILLIAM L. SMEAD
Title: Associate Professor (The Luther M. Keith Professorship in Surgery)
College: Medicine and Public Health
Term: July 1, 2003, through June 30, 2007

Appointment of Chairpersons

July 1, 2003, through June 30, 2004

History of Art
Pathology

Myroslava M. Mudrak*
Michael G. Bissell**

July 1, 2003, through June 30, 2007

Consumer and Textile Sciences

Gong Soog Hong

*Acting

**Interim

Reappointment of Chairpersons/Director

July 1, 2003, through June 30, 2004

Aerospace Engineering and Aviation

Nawal K. Taneja

PERSONNEL ACTIONS (contd)

Reappointment of Chairpersons/Director (contd)

July 1, 2003, through June 30, 2004 (contd)

Computer and Information Science	Stuart H. Zweben
Electrical Engineering	Yuan F. Zheng
Industrial Welding and Systems Engineering	Richard A. Miller
Ophthalmology	Paul A. Weber

July 1, 2003, through June 30, 2007

Animal Sciences	James E. Kinder
History of Art	Mark D. Fullerton (on Administrative Leave 7/1/2003-6/30/2004)
Horticulture and Crop Science	Stephen C. Myers
Human Development and Family Science	Albert J. Davis
School of Natural Resources	Gary W. Mullins

July 1, 2003, through September 30, 2007

Geological Sciences	E. Scott Bair
---------------------	---------------

October 1, 2003, through September 30, 2005

Greek and Latin	David E. Hahm
-----------------	---------------

Leaves of Absence Without Salary

BERYL A. MILLER, Professor, Department of Dance, effective Autumn Quarter 2003, to work as Artistic Director of Bebe Miller Company.

CATHERINE A. HEANEY, Associate Professor, School of Public Health, effective Autumn Quarter 2003, Winter Quarter and Spring Quarter 2004, to accept a visiting appointment at Stanford University.

SYLVIA A. BERRYMAN, Assistant Professor, Department of Philosophy, effective Autumn Quarter 2003, Winter Quarter and Spring Quarter 2004 to accept a visiting appointment at the School of Historical Studies, Institute for Advanced Study, Princeton University, Princeton, NJ.

ALICE C. YEW, Assistant Professor, Department of Mathematics, effective Autumn Quarter 2003, Winter Quarter and Spring Quarter 2004, to visit the University of North Carolina at Chapel Hill, Chapel Hill, NC.

Leave of Absence Without Salary -- Continuation

ROY JOSHUA, Associate Professor, Department of Mathematics, effective Autumn Quarter 2003, to accept a visiting position at the Institute for Advanced Study, Princeton University, Princeton, NJ.

Professional Improvement Leaves

GILBERT J. GREENE, Professor, College of Social Work, effective Autumn Quarter 2003.

HOWARD P. MARVEL, Professor, Department of Economics, effective Autumn Quarter 2003, Winter Quarter and Spring Quarter 2004.

PERSONNEL ACTIONS (contd)

Professional Improvement Leaves (contd)

RICHARD L. MCCREERY, Professor, Department of Chemistry, effective Autumn Quarter 2003, Winter Quarter and Spring Quarter 2004.

REBECCA Y. KIM, Associate Professor, College of Social Work, effective Spring Quarter 2004.

DEHUA PEI, Associate Professor, Department of Chemistry, effective Winter Quarter and Spring Quarter 2004.

Emeritus Titles

JOHN B. ALLRED, Department of Food Science and Technology, with the title Professor Emeritus, effective July 1, 2003.

THOMAS COOLEY, Department of English, with the title Professor Emeritus, effective July 1, 2003.

K. LARRY SMITH, Department of Animal Sciences, with the title Professor Emeritus, effective August 1, 2003.

R. CORY BATES, School of Physical Activity and Educational Services, with the title Associate Professor Emeritus, effective July 1, 2003.

MARY E. KONDRAT, College of Social Work, with the title Associate Professor Emeritus, effective September 1, 2003.

Medical Staff Appointments (The Arthur G. James Cancer Hospital and Richard J. Solove Research Institute)

April 2003

Provisional to Full Appointments

William Abraham, M.D., Associate Attending, James Internal Medicine, Cardiology, 4/7/2003-6/30/2003

Michael Baird, M.D., Associate Attending, James Internal Medicine, Digestive Diseases, 4/7/2003- 6/30/2003

Tanios Bekaii-Saab, M.D., Attending, James Internal Medicine, Hematology/Oncology, 4/7/2003-6/30/2003

Gregory Christoforidis, M.D., Associate Attending, James Radiology, 4/7/2003-6/30/2003

Marcella Dardani, D.O., Associate Attending, James Radiology, 4/7/2003-6/30/2003

Kiran Devulapally, M.D., Associate Attending, James Internal Medicine, General Medicine, 4/7/2003-6/30/2003

Galina Dimitrova, M.D., Associate Attending, James Anesthesiology, 4/7/2003-6/30/2003

Jill Fitch, M.D., Associate Attending, James Pediatrics, Pediatrics Critical Care, 4/7/2003-6/30/2003

Pablo Gamboa, M.D., Associate Attending, James Radiology, 4/7/2003-6/30/2003

Bachar Hachwa, M.D., Associate Attending, James Anesthesiology, 4/7/2003-6/30/2003

Djavid Hadian, M.D., Associate Attending, James Internal Medicine, Cardiology, 4/7/2003-6/30/2003

Grace Hercl, D.O., Associate Attending, James Internal Medicine, General Medicine, 4/7/2003-6/30/2003

Hooman Khabiri, M.D., Associate Attending, James Radiology, 4/7/2003-6/30/2003

Mark King, M.D., Associate Attending, James Radiology, 4/7/2003-6/30/2003

Lawrence Kirschner, M.D., Associate Attending, James Internal Medicine, Endocrinology, 4/7/2003-6/30/2003

PERSONNEL ACTIONS (contd)

Medical Staff Appointments (The Arthur G. James Cancer Hospital and Richard J. Solove Research Institute) (contd)

April 2003 (contd)

Provisional to Full Appointments (contd)

Sumant Lamba, M.D., Associate Attending, James Internal Medicine, Cardiology, 4/7/2003-6/30/2003
Catherine Lucey, M.D., Associate Attending, James Internal Medicine, General Medicine, 4/7/2003-6/30/2003
Thomas McEldowney, D.O., Associate Attending, James Internal Medicine, General Medicine, 4/7/2003-6/30/2004
Randy Mills, D.O., Associate Attending, James Internal Medicine, General Medicine, 4/7/2003-6/30/2004
Julie Niedermier, M.D., Associate Attending, James Psychiatry, 4/7/2003-6/30/2004
Charles Noble, M.D., Community Associate, James Internal Medicine, Cardiology, 4/7/2003-6/30/2004
Jeffrey Poulos, M.D., Associate Attending, James Internal Medicine, General Medicine, 4/7/2003-6/30/2004
David Quinn, M.D., Associate Attending, James Internal Medicine, Digestive Diseases, 4/7/2003-6/30/2004
Milroy Samuel, M.D., Clinical Attending, James OB/GYN, 4/7/2003-6/30/2004
Ganesh Shidham, M.D., Associate Attending, James Internal Medicine, Nephrology, 4/7/2003-6/30/2004
H. Wayne Sloan, M.D., Associate Attending, James Radiology, 4/7/2003-6/30/2004
Michael Stanek, D.O., Attending, James Internal Medicine, Hematology/Oncology, 4/7/2003-6/30/2004
Alex Tambrini, M.D., Community Associate, James Family Medicine, 4/7/2003-6/30/2004
Wm. Vazquez-Choisne, M.D., Community Associate, James Radiology, 4/7/2003-6/30/2004
Kenneth Vitellas, M.D., Associate Attending, James Radiology, 4/7/2003-6/30/2004
Craig Williams, M.D., Associate Attending, James Psychiatry, 4/7/2003-6/30/2004
Yiqing Xu, M.D., Attending, James Internal Medicine, Hematology/Oncology, 4/7/2003-6/30/2004
James Young, M.D., Associate Attending, James Psychiatry, 4/7/2003-6/30/2004
Joseph Yu, M.D., Associate Attending, James Radiology, 4/7/2003-6/30/2004

Medical Staff Reappointments (The Arthur G. James Cancer Hospital and Richard J. Solove Research Institute)

April 2003

Carl M. Allen, D.D.S., James Associate Attending, James Dentistry, 7/1/2003-6/30/2005
Mark W. Arnold, M.D., James Associate Attending, James Surgery, General Surgery, 7/1/2003-6/30/2005
Leona B. Ayers, M.D., James Associate Attending, James Pathology, 7/1/2003- 6/30/2005
Gary E. Barnett, M.D., James Associate Attending, James Pathology, 7/1/2003- 6/30/2005
Rolf F. Barth, M.D., James Associate Attending, James Pathology, 7/1/2003- 6/30/2005
Deborah Bartholomew, M.D., James Associate Attending, James OB/GYN, 7/1/2003-6/30/2005
Susan C. Benes, M.D., James Associate Attending, James Ophthalmology, 7/17/2003- 6/30/2005
Philip F. Binkley, M.D., James Associate Attending, James Internal Medicine, Cardiology, 7/1/2003-6/30/2005
Michael G. Bissell, M.D., Ph.D., James Associate Attending, James Pathology, 7/1/2003-6/30/2005
Carl P. Boesel, M.D., James Associate Attending, James Pathology, 7/1/2003-6/30/2005
Brian L. Bowyer, M.D., James Associate Attending, James Phys Med/Rehab, 7/1/2003-6/30/2005
Ginny L. Bumgardner, M.D., Ph.D., James Associate Attending, James Surgery, Transplant, 7/1/2003-6/30/2005

PERSONNEL ACTIONS (contd)

Medical Staff Reappointments (The Arthur G. James Cancer Hospital and Richard J. Solove Research Institute) (contd)

April 2003 (contd)

William E. Burak, M.D., James Attending, James Surgery, Surgical Oncology, 7/1/2003-6/30/2005
John A. Burns, M.D., James Associate Attending, James Ophthalmology, 7/1/2003-6/30/2005
Kenneth V. Cahill, M.D., James Associate Attending, James Ophthalmology, 7/1/2003-6/30/2005
William E. Carson, III, M.D., James Associate Attending, James Surgery, Surgical Oncology, 7/1/2003-6/30/2005
Albert C. Clairmont, M.D., James Associate Attending, James Phys Med/Rehab, 7/1/2003-6/30/2005
Sam C. Colachis, M.D., James Associate Attending, James Phys Med/Rehab, 7/1/2003-6/30/2005
Charles H. Cook, M.D., James Associate Attending, James Surgery, General Surgery, 7/1/2003-6/30/2005
Harold E. Cook, III, M.D., James Associate Attending, James Anesthesiology, 7/1/2003-6/30/2005
Frederick H. Davidorf, M.D., James Associate Attending, James Ophthalmology, 7/17/2003-6/30/2005
Elizabeth A. Davies, M.D., James Associate Attending, James Surgery, Transplant, 7/1/2003-6/30/2005
John T. Davis, M.D., James Associate Attending, James Surgery, Thoracic/Cardio Surgery, 7/1/2003-6/30/2005
Lawrence A. De Renne, M.D., James Associate Attending, James Pathology, 7/1/2003-6/30/2005
Elmahdi A. Elkhammas, M.D., James Associate Attending, James Surgery, Transplant, 7/1/2003-6/30/2005
William B. Farrar, M.D., James Attending, James Surgery, Surgical Oncology, 7/1/2003-6/30/2005
Ronald M. Ferguson, M.D., James Associate Attending, James Surgery, Transplant, 7/1/2003-6/30/2005
Jill A. Foster, M.D., James Clinical Attending, James Ophthalmology, 7/1/2003-6/30/2005
Wendy L. Frankel, M.D., James Associate Attending, James Pathology, 7/1/2003-6/30/2005
Lucy R. Freedy, M.D., James Associate Attending, James Radiology, 7/1/2003-6/30/2005
Richard A. Freeland, M.D., James Associate Attending, James Psychiatry, 7/1/2003-6/30/2005
Mark A. Gerhardt, M.D., Ph.D., James Associate Attending, James Anesthesiology, 7/1/2003-6/30/2005
Amy S. Gewirtz, M.D., James Associate Attending, James Pathology, 7/1/2003-6/30/2005
Deborah A. Gordish, M.D., James Associate Attending, James Internal Medicine, General Medicine, 7/1/2003-6/30/2005
Glenn P. Gravlee, M.D., James Associate Attending, James Anesthesiology, 7/1/2003-6/30/2003
Jonathan I. Groner, M.D., James Associate Attending, James Surgery, Pediatric Surgery, 7/1/2003-6/30/2005
Bachar Hachwa, M.D., James Associate Attending, James Anesthesiology, 7/1/2003-6/30/2005
Mitchell L. Henry, M.D., James Associate Attending, James Surgery, Transplant, 7/1/2003-6/30/2005
Charles L. Hitchcock, M.D., Ph.D., James Associate Attending, James Pathology, 7/1/2003-6/30/2005
Walter B. Hull, M.D., James Associate Attending, James OB/GYN, 7/1/2003-6/30/2005
Vivek Kadyan, M.D., James Associate Attending, James Phys Med/Rehab, 7/1/2003-6/30/2005
Samir Kahwash, M.D., James Clinical Attending, James Pathology, 7/1/2003-6/30/2005
Melanie S. Kennedy, M.D., James Associate Attending, James Pathology, 7/1/2003-6/30/2005
Robert G. Kloos, D.O., James Associate Attending, James Surgery, General Surgery, 7/1/2003-6/30/2004
Susan L. Koletar, M.D., James Associate Attending, James Internal Medicine, Infectious Disease, 7/1/2003-6/30/2005

PERSONNEL ACTIONS (contd)

Medical Staff Reappointments (The Arthur G. James Cancer Hospital and Richard J. Solove Research Institute) (contd)

April 2003 (contd)

Larry C. Lasky, M.D., James Associate Attending, James Pathology, 7/1/2003-6/30/2005
Richard G. Lembach, M.D., James Associate Attending, James Ophthalmology, 7/1/2003-6/30/2005
Gerard Lozanski, M.D., James Associate Attending, James Pathology, 7/1/2003-6/30/2005
Joel G. Lucas, M.D., James Associate Attending, James Pathology, 7/1/2003-6/30/2005

Requests for Additional Privilege

Sandeep Chopra, M.D., James Community Associate, James Internal Medicine, Cardiology, 4/11/2003-6/30/2003
Charles Noble, M.D., James Community Associate, James Internal Medicine, Cardiology, 4/11/2003-6/30/2003

RESOLUTIONS IN MEMORIAM

Resolution No. 2003-137

Synopsis: Approval of Resolutions in Memoriam is proposed.

RESOLVED, That the Board adopt the following Resolutions in Memoriam and that the President be requested to convey a copy to the families of the deceased.

Perry E. Borchers

The Board of Trustees of The Ohio State University expresses its sorrow upon the death on April 12, 2003, of Perry E. Borchers, Professor Emeritus in the Austin E. Knowlton School of Architecture.

Professor Borchers was a veteran of World War II, an architect, a professor of architecture at The Ohio State University, and an internationally recognized pioneer in the field of architectural photogrammetry. He will be sincerely missed by The Ohio State University community.

Perry Borchers was born in Phoenix, Arizona, on October 22, 1919. A licensed surveyor at the age of sixteen, he followed in his father's footsteps and attended The Ohio State University, where he graduated with honors in 1941 with a bachelor's degree in architecture.

Professor Borchers served his country by volunteering for duty in World War II. He entered the service as a second lieutenant in the Army Corps of Engineers; ending his active service in 1946 as a lieutenant colonel. He commanded the 242nd Engineer Combat Battalion and, while serving with the 77th Infantry Division, made assault landings in the Pacific at Guam, Leyte, Okinawa, and Ie Shima, for which he was awarded the Bronze Star for valor.

Following the war, he attended Columbia University where he earned a Master of Science in Architecture degree in 1947. He continued his education at the Royal Academy of Art in Stockholm, Sweden, where he received an advanced degree in architecture and met his future wife, Myra Powell; an external affairs officer for the Canadian embassy. In 1948 he returned to Ohio State as a professor of architecture, where he taught until 1990.

RESOLUTIONS IN MEMORIAM (contd)

Perry E. Borchers (contd)

His early background as a surveyor, and a chance meeting with Professor Bertil Hallert of Sweden, led to a life-long interest and enthusiasm in applying photogrammetry and stereophotography to the recording and study of historic architecture. As a teacher, he pioneered the use of three-dimensional color projection in his courses on Byzantine and Baroque architecture in Europe, for which he received a McKim Fellowship for three-dimensional recording.

He used his self-developed architectural photogrammetry techniques to document and make measured drawings, many of which are in the Library of Congress, of more than 100 architectural and archeological sites. Of the many awards he received for his life's work, one he particularly valued was a Distinguished Alumni Award from the Knowlton School of Architecture in 1999.

Perry Borchers was predeceased by his wife and his partner in photogrammetric study, Myra. Professor Borchers will live forever in the hearts of his surviving family, and in the heart of the University to which he made such an enormous and lasting contribution.

On behalf of the University community, the Board of Trustees expresses to the family of Professor Perry E. Borchers its deepest sympathy and sense of understanding of their loss. It was directed that this resolution be inscribed upon the minutes of the Board of Trustees and that a copy be tendered to his family as an expression of the Board's heartfelt sympathy.

James W. Hutchens

The Board of Trustees of The Ohio State University expresses its sorrow upon the death on November 15, 2002, of James W. Hutchens, Associate Dean of the College of the Arts and Professor in the Department of Art Education.

Professor Hutchens held a Bachelor of Arts degree, cum laude, from Western Carolina University; a Master of Visual Arts degree from Georgia State University; and a Doctor of Philosophy degree from Florida State University. Professor Hutchens was respected internationally for his expertise in public arts policy, contemporary art, art criticism, arts administration, and art education. He served in a number of administrative positions at The Ohio State University: as an assistant dean of the College of the Arts, as the chairperson of the Department of Art Education and, most recently, as an associate dean of the College of the Arts. He also served as professor and chairperson of the Department of Art at Appalachian State University. Professor Hutchens was a skilled administrator as well as a dedicated and enthusiastic teacher who was devoted to helping his students learn and achieve at the highest level.

His scholarly work was published in *Studies in Art Education*, *Art Education*, *The Journal of Aesthetic Education*, *Design for Arts Education*, the *Arts Education Policy Review*, and a number of anthologies on art, art education, and arts policy. He was co-editor of *Content and Practice in a Postmodern Era* and edited *In Their Own Words: A History of the Development of Doctoral Studies in the United States*.

Professor Hutchens was a member of the Council for Policy Studies in Art Education, the co-chair of the steering committee of The National Arts Education Consortium, and was actively involved in the Transforming Education through the Arts Challenge, the Getty education project, and The Annenberg Challenge for education. He was listed in *Who's Who in American Art* and was affiliated with the John Glenn Institute for Public Service and Public Policy. In September 2002, he received the highest international recognition accorded in the field of art education, when he was named a distinguished fellow of the National Art Education Association.

RESOLUTIONS IN MEMORIAM (contd)

James W. Hutchens (contd)

Professor Hutchens was an active member of the Central Ohio community and served a wide variety of community organizations including the Buckeye Regional Anti-Violence Organization (BRAVO), the Columbus Aids Task Force (CATF), the Log Cabin Republicans, and the Columbus Art League. He was a passionate spokesman for a number of important social causes.

On behalf of the University community, the Board of Trustees expresses to the family of Professor and Associate Dean James W. Hutchens its deepest sympathy and sense of understanding of their loss. It was directed that this resolution be inscribed upon the minutes of the Board of Trustees and that a copy be tendered to his family as an expression of the Board's heartfelt sympathy.

REPORT OF RESEARCH CONTRACTS AND GRANTS

Resolution No. 2003-138

Synopsis: The reports on research and other sponsored program contracts and grants and the summary for April 2003 are presented for Board acceptance.

WHEREAS monies are solicited and received on behalf of the University from governmental, industrial, and other agencies in support of research, instructional activities, and service; and

WHEREAS such monies are received through The Ohio State University Research Foundation:

NOW THEREFORE

BE IT RESOLVED, That the research agreement between The Ohio State University and The Ohio State University Research Foundation for the contracts and grants reported herein during the month of April 2003 be approved.

REPORT ON UNIVERSITY DEVELOPMENT

Resolution No. 2003-139

Synopsis: The report on the receipt of gifts and the summary for April 2003 are presented for Board acceptance.

WHEREAS monies are solicited and received on behalf of the University from alumni, industry, and various individuals in support of research, instructional activities, and service; and

WHEREAS such gifts are received through The Ohio State University Development Fund and The Ohio State University Foundation; and

WHEREAS this report includes the establishment of The Julius F. Stone Chair in Cancer Research; and

WHEREAS this report includes the establishment of thirteen (13) new named endowed funds and the amendment of one (1) named endowed funds:

NOW THEREFORE

REPORT ON UNIVERSITY DEVELOPMENT (contd)

BE IT RESOLVED, That the acceptance of the report from The Ohio State University Development Fund and The Ohio State University Foundation during the month of April 2003 be approved.

TOTAL UNIVERSITY PRIVATE SUPPORT

July through April
2002-03 Compared to 2001-02

GIFT RECEIPTS BY DONOR TYPE

	Dollars July through April		
	<u>2002-03</u>	<u>2001-02</u>	<u>%Change</u>
Individuals:			
Alumni (Current Giving)	\$30,458,858	\$28,073,111	8
Alumni (From Bequests)	<u>3,535,138</u>	<u>4,938,850</u>	(28)
Alumni Total	\$33,993,996	\$33,011,961	3
Non-Alumni (Current Giving)	\$16,062,705	\$13,511,369	19
Non-Alumni (From Bequests)	<u>4,098,766</u>	<u>3,421,533</u>	20
Non-Alumni Total	\$20,161,471	\$16,932,902	19
Individual Total	\$54,155,467	\$49,944,863	8 ^A
Corporations/Corp/Foundations	\$33,770,385	\$36,238,757	(7) ^B
Private Foundations	\$16,185,957	\$16,133,127	---
Associations and Other Organizations	<u>\$6,269,779</u>	<u>\$3,886,045</u>	61 ^C
Total	\$110,381,588	\$106,202,792	4

NOTES

- A Individual giving is up 8% largely due to the fact that gifts of \$10,000 or more are up 12% (434 gifts for \$32.9 million last year; 483 gifts for \$36.7 million this year).
- B Gifts of \$10,000 or more from corporations are down 8% compared with last year (\$27.1 million from 565 gifts this year; \$29.6 million from 554 gifts last year).
- C Giving from associations and other organizations at the \$10,000 or more level is up 96% for July - April of the fiscal year (\$4.7 million from 84 gifts this year; \$2.4 million from 86 gifts last year).

REPORT ON UNIVERSITY DEVELOPMENT (contd)

TOTAL UNIVERSITY PRIVATE SUPPORT (contd)

July from April
2002-03 Compared to 2001-02 (contd)

GIFT RECEIPTS BY PURPOSE

	Dollars July through April		
	<u>2002-03</u>	<u>2001-02</u>	<u>% Change</u>
Gift Receipts to Current Use and Endowment Funds:			
Buildings/Equipment	\$21,350,913	\$18,294,747	17
Faculty Support	\$9,953,570	\$10,813,117	(8)
Program Support	\$58,301,861	\$57,415,295	2
Student Financial Aid	\$14,036,204	\$11,333,313	24
Annual Funds-Colleges/Departments	\$5,797,353	\$7,234,856	(20)
Annual Funds-University	<u>\$941,687</u>	<u>\$1,111,464</u>	(15)
Total	\$110,381,588	\$106,202,792	4

GIFT ADDITIONS TO ENDOWMENT

Dollars
July through April

<u>2002-03</u>	<u>2001-02</u>	<u>% Change</u>
\$32,796,260	\$34,202,311	(4)

REPORT ON UNIVERSITY DEVELOPMENT (contd)

THE OHIO STATE UNIVERSITY DEVELOPMENT FUND

	<u>Previous Gifts</u>	<u>Current Gifts</u>	<u>Total Gifts</u>
<u>Establishment of Named Endowed Funds</u>			
The Jack D. Sparks Endowed Scholarship Fund (Used to provide scholarship support for one John Glenn Fellow participating in the Washington Academic Internship Program; provided by a gift from The Jack D. and Fredda S. Sparks Foundation)		\$50,000.00	\$50,000.00
Robert B. and Dorothy R. Shanks Outstanding Youth Scholarship Endowment Fund (Used to support the Highland County 4-H Program for recognition of outstanding youth in Highland County; provided by gifts from Dorothy Shanks)		\$25,658.00	\$25,658.00
The Ted Coates Scholarship Fund (Used to provide scholarships to students enrolled in the Sport Management Graduate Program; provided by gifts from family and friends of Edward Coates)		\$25,000.00	\$25,000.00

THE OHIO STATE UNIVERSITY FOUNDATION

	<u>Previous Gifts</u>	<u>Current Gifts</u>	<u>Total Gifts</u>
<u>Establishment of Named Endowed Chair</u>			
The Julius F. Stone Chair in Cancer Research (Used to support a chair in cancer research at the Comprehensive Cancer Center – The Arthur G. James Cancer Hospital and Richard J. Solove Research Institute; provided by gifts from Dr. and Mrs. Franz T. Stone II)	\$2,153,323.35		\$2,153,323.35
<u>Establishment of Named Endowed Funds</u>			
The Clark M. and Mary Ernestine (Smith) Fouts Scholarship Fund (Used to provide scholarships to graduates of Harding High School, Zanesville High School, Charles F. Brush High School, and Morgan High School; provided by gifts from Clark M. and Mary Ernestine [Smith] Fouts)		\$1,213,610.00	\$1,213,610.00
The Lou and Jim Petropoulos Athletic Scholarship Fund (Used to supplement the student-athlete grant-in-aid scholarship costs of an undergraduate member of a varsity team; provided by gifts from Lou and Jim Petropoulos)	\$100,000.00		\$100,000.00

REPORT ON UNIVERSITY DEVELOPMENT (contd)

THE OHIO STATE UNIVERSITY FOUNDATION (contd)

	<u>Previous Gifts</u>	<u>Current Gifts</u>	<u>Total Gifts</u>
<u>Establishment of Named Endowed Funds (contd)</u>			
Darrell and Jane Tissot 4-H Endowment Fund (Used to support the Highland County 4-H Program for recognition of outstanding youth in Highland County; provided by gifts from Darrell and Jane Tissot)		\$55,000.00	\$55,000.00
The Larry J. Copeland, M.D. Professorship Fund in Gynecologic Oncology (Used to provide for a professional position to support the advancement of medical knowledge of gynecologic cancer towards finding the cause, innovative treatments, and cure; provided by gifts from grateful patients and friends of Larry J. Copeland)		\$46,815.00	\$46,815.00
The Dr. David C. DeMartini Endowed Fund in Physics (Used to provide a scholarship for a student who is a citizen of the U.S. majoring in physics; provided by gifts from Dr. David DeMartini)		\$32,000.00	\$32,000.00
Johanna and Ramon Johnson Merit Scholarship Fund for Human Ecology (Used to support a University Merit Scholar in the College of Human Ecology; provided by gifts from Dr. Ramon Johnson and Johanna Johnson)		\$30,000.25	\$30,000.25
The Carol Carr Brown Graduate Fund (Used to assist graduate students in either early childhood education or communications; provided by gifts from Robert D. Brown honoring Carol Carr Brown)		\$29,600.00	\$29,600.00
The Henry M. and Ruth W. Pausch Endowed Fellowship Fund (Used to provide a scholarship for one John Glenn Fellow participating in the Washington Academic Internship Program; provided by gifts from Jerry and Lenora Pausch)		\$27,648.00	\$27,648.00
The Dr. William L. Lind Part-Time Clinical Faculty Endowed Award Fund (Used to support an award given to a distinguished part-time clinical faculty member from the Section of Primary Care in the College of Dentistry; provided by a gift from Dr. William L. Lind)		\$25,000.00	\$25,000.00

REPORT ON UNIVERSITY DEVELOPMENT (contd)

THE OHIO STATE UNIVERSITY FOUNDATION (contd)

	<u>Previous Gifts</u>	<u>Current Gifts</u>	<u>Total Gifts</u>
<u>Establishment of Named Endowed Funds (contd)</u>			
The Denis G. Simon Innovation Fund (Used to support activities of the faculty, students, and staff in the Fisher College of Business; provided by a gift from Denis G. Simon)		\$25,000.00	\$25,000.00
<u>Change in Description of Named Endowed Fund</u>			
The Bruce L. Lipton, M.D. Scholarship Fund in Medicine			
Total	<u>\$2,253,323.35</u>	<u>\$1,585,331.25</u>	<u>\$3,838,654.60</u>

THE OHIO STATE UNIVERSITY DEVELOPMENT FUND

Establishment of Named Endowed Funds

The Jack D. Sparks Endowed Scholarship Fund

The Jack D. Sparks Endowed Scholarship Fund was established May 30, 2003, by the Board of Trustees of The Ohio State University, with a gift from The Jack D. and Fredda S. Sparks Foundation.

All gifts are to be invested in the University's Permanent Endowment Fund, under the rules and regulations adopted by the Board of Trustees of The Ohio State University, with the right to invest and reinvest as occasion dictates.

The annual income shall be used to provide scholarship support for one "John Glenn Fellow" participating in the Washington Academic Internship Program of the John Glenn Institute for Public Service and Public Policy. It is the desire of the donor that the scholarship shall be awarded with preference to, but not limited to, students interested in public service. The scholarship shall be awarded by the director of the Washington Academic Internship Program in consultation with the University Committee on Student Financial Aid.

It is the desire of the donor that this fund should benefit the University in perpetuity. If the need for this fund should cease to exist or so diminish as to provide unused income, then another use shall be designated by the Board of Trustees in consultation with the director of the John Glenn Institute for Public Service and Public Policy in order to carry out the desire of the donor.

\$50,000.00

Robert B. and Dorothy R. Shanks
Outstanding Youth Scholarship Endowment Fund

The Robert B. and Dorothy R. Shanks Outstanding Youth Scholarship Endowment Fund was established May 30, 2003, by the Board of Trustees of The Ohio State University, with gifts from Dorothy Shanks of Highland County, Ohio.

REPORT ON UNIVERSITY DEVELOPMENT (contd)

THE OHIO STATE UNIVERSITY DEVELOPMENT FUND (contd)

Establishment of Named Endowed Funds (contd)

Robert B. and Dorothy R. Shanks
Outstanding Youth Scholarship Endowment Fund (contd)

All gifts are to be invested in the University's Permanent Endowment Fund, under the rules and regulations adopted by the Board of Trustees of The Ohio State University, with the right to invest and reinvest as occasion dictates.

The annual income shall be used to support the Highland County 4-H Program for recognition of outstanding youth in Highland County, including OSU Extension 4-H members. All expenditures from this fund shall be approved and administered by the Highland County 4-H Advisory Committee as governed by the preamble.

It is the desire of the donor that this fund should benefit the University in perpetuity. If the need for this fund should cease to exist or so diminish as to provide unused income, then another use shall be designated by the Board of Trustees in consultation with the director of Ohio State University Extension in consultation with the donor.

\$25,658.00

The Ted Coates Scholarship Fund

The Ted Coates Scholarship Fund was established May 30, 2003, by the Board of Trustees of The Ohio State University, with gifts from the family and friends of Edward Coates (Ph.D., 1966).

Ted Coates had a distinguished career as a teacher in the public schools for ten years and at The Ohio State University for 24 years before his retirement in 1987. He was the founder of the Sport Management curriculum and program in the School of Health, Physical Education, and Recreation (now named the School of Physical Activity and Educational Services), and was regarded with highest esteem by his students and colleagues. Dr. Coates died in 2002.

All gifts are to be invested in the University's Permanent Endowment Fund, under the rules and regulations adopted by the Board of Trustees of The Ohio State University, with the right to invest and reinvest as occasion dictates.

The annual income shall provide scholarships to students enrolled in the Sport Management Graduate Program. Selection criteria shall include grade point average, outstanding service beyond the classroom, and outstanding leadership skills. Selection of the recipients shall be made by the dean of the College of Education in consultation with the faculty in Sport Management and the University Committee on Student Financial Aid.

It is the desire of the donors that this fund should benefit the University in perpetuity. If the need for this fund should cease to exist or so diminish as to provide unused income, then another use shall be designated by the Board of Trustees in consultation with the dean of the College of Education in order to carry out the desire of the donors.

\$25,000.00

REPORT ON UNIVERSITY DEVELOPMENT (contd)

THE OHIO STATE UNIVERSITY FOUNDATION

Establishment of Named Endowed Chair

The Julius F. Stone Chair in Cancer Research

The Julius F. Stone Chair Fund in Cancer Research at the Comprehensive Cancer Center – The Arthur G. James Cancer Hospital and Richard J. Solove Research Institute was established August 30, 2000, in accordance with the guidelines approved by the Board of Directors of The Ohio State University Foundation, with gifts from Dr. and Mrs. Franz T. Stone II of Buffalo, New York, and Gulf Stream, Florida. The minimum funding level has been reached and the chair was established May 30, 2003.

All gifts are to be invested by the Foundation, under the rules and regulations adopted by the Foundation's Board of Directors, with the right to invest and reinvest as occasion dictates.

The annual income shall be used to support the salary and cancer research of an eminent faculty member in the Comprehensive Cancer Center – The Arthur G. James Cancer Hospital and Richard J. Solove Research Institute at The Ohio State University as recommended by the director of The Arthur G. James Cancer Hospital and Richard J. Solove Research Institute and the director of the Comprehensive Cancer Center to the senior vice president for Health Sciences and dean of the College of Medicine and Public Health. The activities of the chair holder shall be reviewed no less than every five years by the director of The Arthur G. James Cancer Hospital and Richard J. Solove Research Institute, the director of the Comprehensive Cancer Center, and the senior vice president for Health Sciences and dean of the College of Medicine and Public Health to determine compliance with the intent of the donors as well as the academic and research standards of the University.

It is the desire of the donors that this fund should benefit the University in perpetuity. If the need for this fund should cease to exist or so diminish as to provide unused income, then another use shall be designated by the Foundation Board in consultation with the director of The Arthur G. James Cancer Hospital and Richard J. Solove Research Institute, the director of the Comprehensive Cancer Center, and the senior vice president for Health Sciences and dean of the College of Medicine and Public Health in order to carry out the desire of the donors.

\$2,153,323.35

Establishment of Named Endowed Funds

The Clark M. and Mary Ernestine (Smith) Fouts Scholarship Fund

The Clark M. and Mary Ernestine (Smith) Fouts Scholarship Fund was established May 30, 2003, in accordance with the guidelines approved by the Board of Directors of The Ohio State University Foundation, with gifts from the estates of Clark M. (M.A., 1939) and Mary Ernestine (Smith) Fouts of Sun City, Arizona.

All gifts are to be invested by the Foundation, under the rules and regulations adopted by the Foundation's Board of Directors, with the right to invest and reinvest as occasion dictates.

The annual income shall be used to provide scholarships to graduates of Harding High School (Marion, Ohio), Zanesville High School (Zanesville, Ohio), Charles F. Brush High School (South Euclid-Lyndhurst, Ohio) and Morgan High School (McConnelsville, Ohio) who rank in the upper one-third of their graduating class. With all other qualities being equal and unless prohibited by specific federal or state law, the scholarships shall be awarded with preference to, but not limited to, students enrolled full-time at the Columbus campus of The Ohio State University who are citizens of the United States of America who are of good character. Scholarships may be renewed by the scholarship recipients provided a 3.0 or better grade point average is maintained during a normal course load leading to a degree at The Ohio State University, with renewal

REPORT ON UNIVERSITY DEVELOPMENT (contd)

THE OHIO STATE UNIVERSITY FOUNDATION (contd)

Establishment of Named Endowed Funds (contd)

The Clark M. and Mary Ernestine (Smith) Fouts Scholarship Fund (contd)

privilege continuing through completion of a graduate degree at the University. Any recipient found guilty of an infraction involving University regulations or municipal, state, or federal laws shall forfeit his/her scholarship and any renewal thereof.

Dependent upon annual income available, the amount of each scholarship may range from a full scholarship to an amount necessary to supplement a student's available funds. The potential contributions of a student as a citizen shall carry more weight in his/her selection than financial need alone. If the annual income proves inadequate to provide scholarships for the graduates of each of the four high schools named, then preference will be given to those high schools as listed in the following order: Marion Harding High School, Zanesville High School, Morgan High School, and Brush High School.

Selection of the scholarship recipients shall be made by the University Committee on Student Financial Aid upon recommendations from each of the named high schools. In the event that one or more of the designated high schools shall no longer exist as an accredited institution, the scholarships are to be given to graduates of public high schools to which students from those districts are assigned.

It is the desire of the donors that this fund should benefit the University in perpetuity. If the need for this fund should cease to exist or so diminish as to provide unused income, then another use shall be designated by the Foundation Board in order to carry out the desire of the donors.

\$1,213,610.00

The Lou and Jim Petropoulos Athletic Scholarship Fund

The Lou and Jim Petropoulos Athletic Scholarship Fund was established May 30, 2003, in accordance with the guidelines approved by the Board of Directors of The Ohio State University Foundation, with gifts from Lou and Jim Petropoulos of Columbus, Ohio.

All gifts are to be invested by the Foundation, under the rules and regulations adopted by the Foundation's Board of Directors, with the right to invest and reinvest as occasion dictates.

The annual income shall be used to supplement the student-athlete grant-in-aid scholarship costs of a student athlete who is a member of a varsity team pursuing an undergraduate degree at The Ohio State University. The recipient will be selected by the director of Athletics in consultation with the University Committee on Student Financial Aid.

It is the desire of the donors that this fund should benefit the University in perpetuity. If the need for this fund should cease to exist or so diminish as to provide unused income, then another use shall be designated by the Foundation Board as recommended by the director of Athletics in order to carry out the desire of the donors.

\$100,000.00

REPORT ON UNIVERSITY DEVELOPMENT (contd)

THE OHIO STATE UNIVERSITY FOUNDATION (contd)

Establishment of Named Endowed Funds (contd)

Darrell and Jane Tissot 4-H Endowment Fund

The Darrell and Jane Tissot 4-H Endowment Fund was established May 30, 2003, in accordance with the guidelines approved by the Board of Directors of The Ohio State University Foundation, with gifts from Darrell and Jane Tissot of Hillsboro, Ohio.

All gifts are to be invested by the Foundation, under the rules and regulations adopted by the Foundation's Board of Directors, with the right to invest and reinvest as occasion dictates.

The annual income shall be used to support the Highland County 4-H Program for recognition of outstanding youth in Highland County, including OSU Extension 4-H members. All expenditures from this fund shall be approved and administered by the Highland County 4-H Advisory Committee as governed by the preamble.

It is the desire of the donors that this fund should benefit the University in perpetuity. If the need for this fund should cease to exist or so diminish as to provide unused income, then another use shall be designated by the Foundation Board in consultation with the director of Ohio State University Extension, the donor, and the Highland County OSU Extension Faculty.

\$55,000.00

The Larry J. Copeland, M.D. Professorship Fund in Gynecologic Oncology

The Larry J. Copeland, M.D. Professorship Fund in Gynecologic Oncology was established May 30, 2003, in accordance with the guidelines approved by the Board of Directors of The Ohio State University Foundation, with gifts from grateful patients and friends made to the OSU Foundation in honor of Larry J. Copeland, M.D., physician and friend.

All gifts are to be invested by the Foundation, under the rules and regulations adopted by the Foundation's Board of Directors, with the right to invest and reinvest as occasion dictates.

The annual income shall provide for a professorship position to support the advancement of medical knowledge of gynecologic cancer towards finding the cause, innovative treatments, and cure. Support shall be provided to a distinguished teacher, practitioner, and researcher in the College of Medicine and Public Health. The appointment shall be made at the recommendation of the chairperson of the Department of Obstetrics and Gynecology in consultation with the senior vice president for Health Sciences and dean of the College of Medicine and Public Health to the provost and approved by the Board of Trustees. Until the minimum funding level is reached, the endowment income shall be reinvested in the endowment principal. In any given year that the endowment income is not fully expended, the unused portion should be reinvested in the endowment principal.

It is the desire of the donors that this fund should benefit the University in perpetuity. If the need for this fund should cease to exist or so diminish as to provide unused income, then another use shall be designated by the Foundation Board in consultation with the senior vice president for Health Sciences and dean of the College of Medicine and Public Health and the chairperson of the Department of Obstetrics and Gynecology in order to carry out the desire of the donors.

\$46,815.00

REPORT ON UNIVERSITY DEVELOPMENT (contd)

THE OHIO STATE UNIVERSITY FOUNDATION (contd)

Establishment of Named Endowed Funds (contd)

The Dr. David C. DeMartini Endowed Fund in Physics

The Dr. David C. DeMartini Endowed Fund in Physics was established May 30, 2003, in accordance with the guidelines approved by the Board of Directors of The Ohio State University Foundation, with gifts from Dr. David DeMartini (Ph.D., 1969) of Houston, Texas.

All gifts are to be invested by the Foundation, under the rules and regulations adopted by the Foundation's Board of Directors, with the right to invest and reinvest as occasion dictates.

The annual income shall be used to provide a scholarship for an undergraduate or graduate student majoring in physics. With all other qualities being equal and unless prohibited by specific federal or state law, the scholarships shall be awarded with preference to, but not limited to, students who are citizens of the United States of America based on academic achievement, moral character, and financial need, in that order, and in the opinion of and sole discretion of the chairperson of the Department of Physics. Scholarships will be awarded in consultation with the University Committee on Student Financial Aid. Any unused income will be returned to the principal of this fund.

It is the desire of the donor that this fund should benefit the University in perpetuity. If the need for this fund should cease to exist or so diminish as to provide unused income, then another use shall be designated by the Foundation Board in consultation with the appropriate college dean, department chairperson, or program administrative officer in order to carry out the desire of the donor.

\$32,000.00

Johanna and Ramon Johnson Merit Scholarship Fund for Human Ecology

The Johanna and Ramon Johnson Merit Scholarship Fund for Human Ecology was established May 30, 2003, in accordance with the guidelines approved by the Board of Directors of The Ohio State University Foundation, with gifts from Dr. Ramon Johnson (D.D.S., 1957) and Johanna Johnson (B.S.H.E., 1956) of Urbana, Ohio.

All gifts are to be invested by the Foundation, under the rules and regulations adopted by the Foundation's Board of Directors, with the right to invest and reinvest as occasion dictates.

The Johanna and Ramon Johnson Merit Scholarship for Human Ecology is the first Merit Scholarship to be awarded to the College of Human Ecology. The annual income shall be used to support a University Merit Scholar each year so long as the recipient(s) maintains the required grade point average. This scholarship fund is restricted to sophomore students enrolled in or planning to enroll in the College of Human Ecology and major in nutrition, with second preference being a sophomore student pursuing a degree in education while taking course work in the College of Human Ecology. The scholarship recipient(s) will be selected according to the criteria established by the Honors and Scholars program in consultation with the assistant dean of Undergraduate Studies in the College of Human Ecology and the chairperson of the Department of Human Nutrition under the authority of the dean of the College of Human Ecology. Scholarships will be awarded in consultation with the University Committee on Student Financial Aid.

REPORT ON UNIVERSITY DEVELOPMENT (contd)

THE OHIO STATE UNIVERSITY FOUNDATION (contd)

Establishment of Named Endowed Funds (contd)

Johanna and Ramon Johnson Merit Scholarship Fund for Human Ecology (contd)

It is the desire of the donors that this fund should benefit the University in perpetuity. If the need for this fund should cease to exist or so diminish as to provide unused income, then another use shall be designated by the Foundation Board in consultation with the dean of the College of Human Ecology, the associate provost of Honors and Scholars, and the Office of Student Financial Aid in order to carry out the desire of the donors.

\$30,000.25

The Carol Carr Brown Graduate Fund

The Carol Carr Brown Graduate Fund was established May 30, 2003, in accordance with the guidelines approved by the Board of Directors of The Ohio State University Foundation, with gifts from Robert D. Brown in honor of his wife, Carol Carr Brown (B.S.Ed., 1966; M.A., 1972; Ph.D., 1977).

All gifts are to be invested by the Foundation, under the rules and regulations adopted by the Foundation's Board of Directors, with the right to invest and reinvest as occasion dictates.

The annual income shall be used to assist a graduate student(s) in either early childhood education or communications. Selection shall be made by the dean of the Graduate School, in consultation with the University Committee on Student Financial Aid.

It is the desire of the donor that this fund should benefit the University in perpetuity. If the need for this fund should cease to exist or so diminish as to provide unused income, then another use shall be designated by the Foundation Board in consultation with the dean of the Graduate School in order to carry out the desire of the donor.

\$29,600.00

The Henry M. and Ruth W. Pausch Endowed Fellowship Fund

The Henry M. and Ruth W. Pausch Endowed Fellowship Fund was established May 30, 2003, in accordance with the guidelines approved by the Board of Directors of The Ohio State University Foundation, with gifts from Jerry (B.Ch.E., 1961) and Lenora (B.S., 1963) Pausch of Leesburg, Ohio.

All gifts are to be invested by the Foundation, under the rules and regulations adopted by the Foundation's Board of Directors, with the right to invest and reinvest as occasion dictates.

The annual income shall be used to provide scholarship support for one "John Glenn Fellow" participating in the Washington Academic Internship Program through the John Glenn Institute for Public Service and Public Policy. It is the desire of the donor that the scholarship shall be awarded with preference to, but not limited to, students from Highland County. The recipient will be selected by the director of the Washington Academic Internship Program in consultation with the University Committee on Student Financial Aid.

It is the desire of the donors that this fund should benefit the University in perpetuity. If the need for this fund should cease to exist or so diminish as to provide unused income, then another use shall be designated by the Foundation Board in consultation with the director of the John Glenn Institute for Public Service and Public Policy in order to carry out the desire of the donors.

\$27,648.00

REPORT ON UNIVERSITY DEVELOPMENT (contd)

THE OHIO STATE UNIVERSITY FOUNDATION (contd)

Establishment of Named Endowed Funds (contd)

The Dr. William L. Lind Part-Time Clinical Faculty Endowed Award Fund

The Dr. William L. Lind Part-Time Clinical Faculty Endowed Award Fund was established May 30, 2003, in accordance with the guidelines approved by the Board of Directors of The Ohio State University Foundation, with a gift from Dr. William L. Lind (D.D.S., 1961) of Powell, Ohio.

All gifts are to be invested by the Foundation, under the rules and regulations adopted by the Foundation's Board of Directors, with the right to invest and reinvest as occasion dictates.

The annual income shall be used to support an award given to a distinguished, part-time, clinical faculty member from the Section of Primary Care in The Ohio State University College of Dentistry. The dean of the College of Dentistry, in consultation with the head of the Section of Primary Care, shall be responsible for making the award.

It is the desire of the donor that this fund should benefit the University in perpetuity. If the need for this fund should cease to exist or so diminish as to provide unused income, then another use shall be designated by the Foundation Board in consultation with the dean of the College of Dentistry in order to carry out the desire of the donor.

\$25,000.00

The Denis G. Simon Innovation Fund

The Denis G. Simon Innovation Fund was established May 30, 2003, in accordance with the guidelines approved by the Board of Directors of The Ohio State University Foundation, with a gift from Denis G. Simon (B.S.Bus.Adm., 1969) of Dallas, Texas.

All gifts are to be invested by the Foundation, under the rules and regulations adopted by the Foundation's Board of Directors, with the right to invest and reinvest as occasion dictates.

The annual income shall be used by the dean of The Max M. Fisher College of Business to support activities of the faculty, students, and staff in accordance with the strategic plans of the college.

It is the desire of the donor that this fund should benefit the University in perpetuity. If the need for this fund should cease to exist or so diminish as to provide unused income, then another use shall be designated by the Foundation Board in consultation with the dean of the Fisher College of Business in order to carry out the desire of the donor.

\$25,000.00

Change in Description of Named Endowed Fund

The Bruce L. Lipton, M.D. Scholarship Fund in Medicine

The Bruce L. Lipton, M.D., Scholarship Fund in Medicine was established on February 1, 2002, in accordance with the guidelines approved by the Board of Directors of The Ohio State University Foundation, with gifts to the Foundation in memory of Bruce L. Lipton, M.D. (B.S., 1958; M.D., 1962) of Liberty Township, Ohio. The description was revised on May 30, 2003.

REPORT ON UNIVERSITY DEVELOPMENT (contd)

THE OHIO STATE UNIVERSITY FOUNDATION (contd)

Change in Description of Named Endowed Fund (contd)

The Bruce L. Lipton, M.D. Scholarship Fund in Medicine (contd)

Dr. Lipton's career and life were marked by his pursuit of excellence in medicine, his commitment to his family and to the Mahoning Valley area, and his loyalty to his alma mater, The Ohio State University. This fund was initiated by The Ohio State University Alumni Club of Mahoning County and supported by the family, classmates, colleagues, and friends of Dr. Lipton.

All gifts are to be invested by the Foundation, under the rules and regulations adopted by the Foundation Board of Directors of The Ohio State University with the right to invest and reinvest as occasion dictates.

The annual income shall provide one or more scholarships to first-year medical students, and may be extended to second-year students, who are enrolled in the College of Medicine and Public Health and are from Trumbull, Mahoning, or Columbiana Counties in Ohio. The selection of the recipient(s) shall be based on academic merit and financial need, and shall be approved by the senior vice president for Health Sciences and dean of the College of Medicine and Public Health upon consultation with an ad hoc committee comprised of one representative each from the OSU Alumni Club of Mahoning County, the family of Bruce L. Lipton, M.D., and the College of Medicine and Public Health Committee for Scholarship Awards. This committee shall be chaired by the president of the aforementioned alumni club and shall consult with the University Committee on Student Financial Aid and with the College of Medicine and Public Health Committee for Scholarship Awards.

It is the desire of the donors that this fund should benefit the University in perpetuity. If the need for this fund should cease to exist or so diminish as to provide unused income, then another use shall be designated by the Board of Trustees in consultation with the senior vice president for Health Sciences and dean of the College of Medicine and Public Health and with the ad hoc committee in order to carry out the desire of the donors.

AMENDMENTS TO TRANSPORTATION AND PARKING REGULATIONS

Resolution No. 2003-140

Synopsis: Approval of the following amendments to the *Traffic and Parking Regulations* are recommended.

WHEREAS on November 3, 1978, the Board adopted *Motor Vehicle, Traffic and Parking Regulations* of The Ohio State University, which were subsequently amended further June 10, 1982; and

WHEREAS there is a need to update those regulations and the Board is being requested to approve revised regulations for transportation and parking on the campus as attached:

NOW THEREFORE

BE IT RESOLVED, That the name change and revised *Transportation and Parking Regulations* of The Ohio State University be adopted by the Board of Trustees.

(See Appendix LIII for background information, page 1199.)

CAPITAL PROJECTS

Resolution No. 2003-141

REQUEST FOR DESIGN AUTHORIZATION

ATI – RESURFACE GARRISON CIRCLE EAST
ATI – VARIOUS CONCRETE WORK
ATWELL HALL – ROOF REPLACEMENT
BRICKER HALL – ROOF REPLACEMENT
CAMPUS BUILDINGS – ELEVATOR HYDRAULIC CYLINDER REPLACEMENT
CAMPUS GROUNDS – NEIL AVENUE CORRIDOR
COMPREHENSIVE CANCER CENTER – CHILLER REPLACEMENT
DOAN HALL – RENOVATION SUITE 236 PET/CT UNIT
KOTTMAN HALL 103 CLASSROOM RENOVATION
LIMA CAMPUS – CAMPUS DRIVE RESURFACE
LIMA CAMPUS – GALVIN HALL 4TH FLOOR RENOVATION
LIMA CAMPUS – OVERFLOW PARKING LOT RENOVATION
PARKS HALL – CHILLER REPLACEMENT
TOWNSHEND HALL – ROOF REPLACEMENT
TZAGOURNIS MEDICAL RESEARCH FACILITY - ROOM 190
VETERINARY HOSPITAL – ROOF REPLACEMENT PHASE II
WISEMAN HALL – BUILDOUT OF 3RD FLOOR SHELL SPACE

REQUEST FOR CONSTRUCTION AUTHORIZATION

JAMES CANCER HOSPITAL – 3 EAST AND 3 SOUTH
LARKINS NATATORIUM SCOREBOARD
NEIL AVENUE GARAGE
OARDC – PIKETON TRAINING AND DEVELOPMENT CENTER
OHIO 4-H CENTER

Synopsis: Authorization to enter into design contracts for ATI – Resurface Garrison Circle East, ATI – Various Concrete Work, Atwell Hall-Roof Replacement, Bricker Hall-Roof Replacement, Campus Buildings-Elevator Hydraulic Cylinder Replacement, Campus Grounds-Neil Avenue Corridor, Comprehensive Cancer Center – Chiller Replacement, Doan Hall – Renovations Suite 236 PET/CT Unit, Kottman Hall 103 Classroom Renovation, Lima Campus – Campus Drive Resurface, Lima Campus – Galvin Hall 4th Floor Renovation, Lima Campus – Overflow Parking Lot Renovation, Parks Hall – Chiller Replacement, Townshend Hall – Roof Replacement, Tzagournis Medical Research Facility – Room 190, Veterinary Hospital – Roof Replacement Phase II, Wiseman Hall-Buildout of 3rd Floor Shell Space and construction contracts for James Cancer Hospital-3 East and 3 South, Larkins Natatorium Scoreboard, Neil Avenue Garage, OARDC-Piketon Training and Development Center, Ohio 4-H Center is requested.

WHEREAS the University desires to seal and resurface roadways and the east parking lot at the Agricultural technical Institute; and

WHEREAS the current project estimate is \$85,000 with funding to be provided by HB 675; and

WHEREAS at ATI the University desires to replace the Skou Hall south entry, Bee Lab entry, and miscellaneous sidewalks; and

WHEREAS the current project estimate is \$50,000 with funding to be provided by HB 640; and

WHEREAS the University desires to replace the roof on Atwell Hall; and

WHEREAS the current project estimate is \$375,000 with funding to be provided by HB 675; and

WHEREAS the University desires to replace the roof on Bricker Hall; and

WHEREAS the current project estimate is \$500,000 with funding to be provided by HB 675; and

CAPITAL PROJECTS (contd)

WHEREAS the University desires to replace the hydraulic elevator cylinders in numerous campus buildings with updated double bulk head cylinders with PVC piping to meet current code; and

WHEREAS the current project estimate is \$575,000 with funding to be provided by HB 675; and

WHEREAS on the east side of Neil Avenue between 11th and 12th Avenues the University desires to upgrade street and sidewalk signaling to improve traffic flow and enhance pedestrian safety; and

WHEREAS the current project estimate is \$750,000, with funding to be provided by HB 675; and

WHEREAS the University desires to replace the 22 year old chiller in the Comprehensive Cancer Center to improve cooling and air circulation; and

WHEREAS the current project estimate is \$400,000, with funding to be provided by HB 675; and

WHEREAS the University desires to renovate a section of the Radiology Files Room 236 in Doan Hall to install a PET/CT Imaging unit; and

WHEREAS the current project estimate is \$372,874; with funding to be provided by the James Cancer Hospital and Solove Research Institute; and

WHEREAS the University desires to renovate 103 Kottman Hall, a 274 capacity lecture hall, to include improvements in finish, seating, chalkboard, audio-visual equipment, lighting replacement and refurbishment of the projection booth; and

WHEREAS the current project estimate is \$607,833 with funding to be provided by HB 675; and

WHEREAS at the Lima Campus the University desires to grind and resurface Campus Drive and adjacent parking lots; and

WHEREAS the current project estimate is \$54,978 with funding to be provided by HB 640; and

WHEREAS the University desires to renovate approximately 5,000 square feet of administrative and instructional space of the north portion of Galvin Hall on the Lima Campus; and

WHEREAS the current project estimate is \$367,657 with funding to be provided by HB 850; and

WHEREAS the University desires to renovate an existing three-acre gravel overflow parking area on the southwest side of Campus Drive on the Lima Campus; and

WHEREAS the current project estimate is \$292,991 with funding to be provided by the Lima Campus; and

WHEREAS the University desires to replace the 26-year old chiller in Parks Hall to improve cooling and air circulation; and

WHEREAS the current project estimate is \$800,000 with funding to be provided by HB 675; and

WHEREAS the University desires to replace the roof on Townshend Hall; and

WHEREAS the current project estimate is \$1,000,000 with funding to be provided by HB 675; and

WHEREAS the University desires to renovate Room 190 of Tzagournis Medical Research Facility to house an animal MRI center; and

WHEREAS the current project estimate is \$357,490 with funding to be provided College of Medicine and Public Health development funds; and

CAPITAL PROJECTS (contd)

WHEREAS the University desires to remove and replace the Veterinary Hospital roof; and

WHEREAS the current project estimate is \$650,000 with funding to be provided by HB 675; and

WHEREAS the University desires to build out the shell space of the third floor of Wiseman Hall; and

WHEREAS the current project estimate is \$3,569,940 with funding to be provided by the James Cancer Hospital and Solove Research Institute; and

WHEREAS the University desires to upgrade patient rooms and renovate nurses stations and hallways on the 3rd floor and 5th floor of the James Cancer Hospital; and

WHEREAS the construction document project cost is \$2,134,250 with funding to be provided by the James Cancer Hospital and Solove Research Institute; and

WHEREAS the University desires to install a scoreboard to be used in the new natatorium facility of the Larkins Hall replacement project; and

WHEREAS the project cost estimate is \$529,560 with funding to be provided by future University bond proceeds with debt service to be paid by the Department of Athletics; and

WHEREAS the University desires to increase the capacity of the garage to be built in association with the Larkins Hall replacement project by approximately two floors for 240 additional parking spaces; and

WHEREAS the construction document project cost for this expanded project is \$14,838,471, with funding for the cost increase to be provided by excess funding to be transferred from the Hospital Garage project; and

WHEREAS the University desires to construct a new multi-purpose building at Piketon for use by OARDC as a technology center and business incubator center; and

WHEREAS the construction document cost is \$3,090,000 with funding to be provided by an Appalachian Regulatory Commission Grant (\$270,000), an Economic Development Administration Grant (\$1,920,000), and HB 675 (\$900,000); and

WHEREAS the University desires to build a new Ohio 4-H Center; and

WHEREAS the construction document cost has been revised from \$9,100,000 to \$10,000,000 to increase the building size to accommodate programming needs with all funding to be provided by College of Food, Agricultural and Environmental Sciences development funds.

NOW THEREFORE

BE IT RESOLVED, that the President an/or Senior Vice President for Business and Finance be authorized to select qualified architectural/engineering firms as necessary for ATI – Resurface Garrison Circle East, ATI – Various Concrete Work, Atwell Hall-Roof Replacement, Bricker Hall-Roof Replacement, Campus Buildings-Elevator Hydraulic Cylinder Replacement, Campus Grounds-Neil Avenue Corridor, Comprehensive Cancer Center – Chiller Replacement, Doan Hall – Renovations Suite 236 PET/CT Unit, Kottman Hall 103 Classroom Renovation, Lima Campus – Campus Drive Resurface, Lima Campus – Galvin Hall 4th Floor Renovation, Lima Campus – Overflow Parking Lot Renovation, Parks Hall – Chiller Replacement, Townshend Hall – Roof Replacement, Tzagournis Medical Research Facility – Room 190, Veterinary Hospital – Roof Replacement Phase II, Wiseman Hall-Buildout of 3rd Floor Shell Space; and

CAPITAL PROJECTS (contd)

BE IT FURTHER RESOLVED, that the President and/or Senior Vice President for Business and Finance be authorized to request construction bids for James Cancer Hospital-3 East and 3 South, Larkins Natatorium Scoreboard, Neil Avenue Garage, OARDC-Piketon Training and Development Center, Ohio 4-H Center are hereby accepted.

(See Appendix LIV for background information and maps, page 1241.)

INTERIM BUDGET FOR FISCAL YEAR 2003-04

Resolution No. 2003-142

Synopsis: Authorization to make expenditures in 2003-2004 is proposed.

WHEREAS the Ohio General Assembly has not yet passed the 2003-2005 Biennial Budget including the level of funding for Higher Education for Fiscal Year 2003-04; and

WHEREAS having approved student fee increases for Fiscal Year 2003-04, the University has not yet finalized its operating budget for Fiscal Year 2003-04; and

WHEREAS it is necessary to continue University expenditures, including payment of faculty and staff, prior to the time that the Current Funds Budget for 2003-04 is developed and adopted:

NOW THEREFORE

BE IT RESOLVED, That the University be authorized to make expenditures consistent with the level of resources approved for Fiscal Year 2002-03, pending the adoption of the Current Funds Budget for 2003-04 at the September Board meeting.

**2003-2004 GRADUATE AND PROFESSIONAL TUITION, GENERAL AND STUDENT
ACTIVITY FEES, AND OTHER SELECTED FEE INCREASES**

Resolution No. 2003-143

Synopsis: Instructional and Nonresident fees for Graduate and Professional students, the General and Student Activity Fees for all students at the Columbus Campus, and other selected fees for Fiscal Year 2003-2004 are proposed effective Autumn Quarter 2003.

WHEREAS the Board of Trustees of The Ohio State University approved the Undergraduate Instructional, General and Nonresident fees for all campuses to be effective Summer Quarter 2003 at their May 2, 2003 meeting; and

WHEREAS the professional colleges have now completed consultations with their students in regards to the level of their instructional fees above a 6% base to be used by those colleges to improve services to their students; and

WHEREAS consultations have taken place concerning the inclusion of a Student Activity Fee component within the General Fee at the Columbus Campus and those fees need to be approved for FY 2003-2004; and

WHEREAS other selected fees need to be approved for FY 2003-2004:

NOW THEREFORE

**2003-2004 GRADUATE AND PROFESSIONAL TUITION, GENERAL AND STUDENT
ACTIVITY FEES, AND OTHER SELECTED FEE INCREASES (contd)**

BE IT RESOLVED, That the Graduate Resident fees (Instructional and General) for the Columbus Campus be increased 9.0% (\$198 per quarter for a full time student) effective Autumn Quarter 2003 except those specific programs that have opted for a higher differential fee; and

BE IT FURTHER RESOLVED, That the Graduate Resident fees (Instructional and General) for the Regional Campuses be increased 9.0% (\$194 per quarter for a full time student) effective Autumn Quarter 2003; and

BE IT FURTHER RESOLVED, That Differential (Instructional) Fees for the Professional Colleges and specific graduate programs at the Columbus Campus be increased in accordance with the attached budget materials effective Autumn Quarter 2003, including one new Masters differential fee in the College of Medicine and Public Health for Occupational Therapy; and

BE IT FURTHER RESOLVED, That the Nonresident Surcharges for all graduate and professional students at all Campuses will increase 6.0% in accordance with the attached budget materials effective Autumn Quarter 2003; and

BE IT FURTHER RESOLVED, That effective Autumn Quarter 2003 at the Columbus Campus the General Fee for all continuing undergraduate students will be \$117 per quarter (same as Summer Quarter 2003); and for all new undergraduate students will be \$132 per quarter coupled with a corresponding \$15 per quarter decrease in the new undergraduate (Tier 3) instructional fee from Summer Quarter; and with the additional general fees for new students earmarked for student activities which will replace the current voluntary \$2 Student Government Contribution; and

BE IT FURTHER RESOLVED, That effective Autumn Quarter 2003 at the Columbus Campus the General Fee for all continuing graduate and professional students will be \$117 per quarter (\$176 per semester, the same as Summer Quarter 2003); and there will be a separate Student Activity Fee of \$15 per quarter (\$22 per semester) for all new graduate and professional students with these additional funds earmarked for student activities and will replace the current voluntary \$2 Student Government Contribution; and

BE IT FURTHER RESOLVED, That other selected fees at the Columbus Campus will increase for FY 2004 in accordance with the attached budget materials.

(See Appendix LV for background information, page 1305.)

Upon motion of Ms. Longaberger, seconded by Mrs. Davidson, the Board of Trustees adopted the foregoing resolutions by unanimous roll call vote, cast by Messrs. Sofia, Slane, McFerson, Borrer, O'Dell, and Judge Duncan, Mses. Longaberger, Hendricks, and Davidson.

Mr. O'Dell:

Before I cast my ballot, I'd like to say what an honor it is to serve this great University. Chairman Sofia and President Holbrook, thank you for your very kind words. And, of course, I vote yes.

Mr. Sofia:

I was worried for a while!

--0--

**AUTHORIZATION, ISSUANCE AND SALE OF
GENERAL RECEIPTS COMMERCIAL PAPER NOTES, SERIES E, OF
THE OHIO STATE UNIVERSITY**

Resolution No. 2003-144

Synopsis: Providing for the authorization, issuance and sale of General Receipts Commercial Paper Notes, Series E (the "Series E Notes"), in a principal amount determined as provided herein, for the purpose of (i) financing the Series E Project, as defined herein, (ii) currently refunding certain outstanding Obligations and (iii) paying costs and expenses associated with the issuance of the Series E Notes, authorizing a Series E Supplement to Amended and Restated Trust Indenture to secure the payment of Debt Service Charges on the Series E Notes is proposed.

WHEREAS pursuant to Sections 3345.11 and 3345.12 of the Ohio Revised Code (the "Act"), as enacted under authority of the Constitution of Ohio, particularly Section 2i of Article VIII thereof, The Ohio State University (the "University"), a state university of the State of Ohio (the "State"), created and existing under Chapter 3335 of the Ohio Revised Code, is authorized and empowered, among other things, (a) to issue, as provided herein, Obligations (as defined in the Indenture (as hereinafter defined)) of the University to pay the costs of certain capital facilities defined as "facilities" in the Act (and herein called "University Facilities") and to refund, fund or retire bonds and other obligations previously issued for such purpose; (b) to pledge to the payment of the Obligations all or a specified part of the gross amount of the General Receipts of the University (as defined in the Original Indenture) in priority to all other expenses, claims or payments; (c) to covenant, as herein provided, that the University will make, fix, adjust and collect the fees, rates, rentals, charges and other items comprising General Receipts to produce General Receipts sufficient at all times to meet Debt Service Charges (as defined in the Amended and Restated Trust Indenture described below) on the Obligations, to establish and to maintain the required reserves and meet other requirements herein provided; and (d) to provide for a trust indenture and make further provisions for securing the payment of the Debt Service Charges; and

WHEREAS the University, by resolution adopted by its Board of Trustees (the "Board") on November 1, 1985 (the "Series 1985 A Bond Resolution") and by a Trust Indenture dated as of November 15, 1985 (the "Original Indenture") between the University and The Huntington National Bank, as Trustee (the "Trustee"), provided for the issuance from time to time of General Receipts Bonds of the University; and

WHEREAS the University, pursuant to the terms of a resolution adopted by the Board on October 1, 1999 (the "1999 General Bond Resolution") amended and restated the Original Indenture, as supplemented in accordance with the terms thereof by entering into the Amended and Restated Trust Indenture dated as of December 1, 1999 (the "Amended and Restated Trust Indenture") with the Trustee; and

WHEREAS the Amended and Restated Indenture provides that Obligations, as defined therein, may be issued pursuant to the terms thereof, with each such issue to be authorized by a Series Resolution, as defined therein, adopted by the Board and secured pursuant to the terms of a Supplemental Indenture, as defined in the Amended and Restated Indenture with respect to such issue (the Amended and Restated Indenture and all Supplemental Indentures thereto being collectively referred to herein as the "Indenture"); and

WHEREAS the University has authorized the issuance pursuant to the 1999 General Bond Resolution, the resolution adopted by the Board on November 5, 1999 (the "Series 1999 A General Receipts Bond Resolution"), the Indenture and the First Supplement to Amended and Restated Trust Indenture, dated as of December 1, 1999 (the "First Supplement") between the University and the Trustee, \$83,585,000 The Ohio State University General Receipts Bonds, Series 1999 A (the "Series 1999 A Bonds") of which authorized amount \$75,190,000 is issued and outstanding as of the date hereof; and

**AUTHORIZATION, ISSUANCE AND SALE OF
GENERAL RECEIPTS COMMERCIAL PAPER NOTES, SERIES E, OF
THE OHIO STATE UNIVERSITY (contd)**

WHEREAS the University has authorized the issuance pursuant to the 1999 General Bond Resolution, the resolution adopted by the Board on November 5, 1999 (the "Series 1999 B General Receipts Bond Resolution"), the Indenture and the Second Supplement to Amended and Restated Trust Indenture, dated as of December 1, 1999 (the "Second Supplement") between the University and the Trustee, \$108,000,000 The Ohio State University Variable Rate Demand General Receipts Bonds, Series 1999 B (the "Series 1999 B Bonds") of which authorized amount \$84,900,000 is issued and outstanding as of the date hereof; and

WHEREAS the University has authorized the issuance pursuant to the 1999 General Bond Resolution, the Resolution adopted by the Board on November 2, 2001 (the "Series 2001 General Receipts Bond Resolution"), the Indenture and the Series 2001 Supplement to Amended and Restated Trust Indenture, dated as of November 1, 2001 (the "Series 2001 Supplement") between the University and the Trustee, \$79,950,000 The Ohio State University Variable Rate Demand General Receipts Bonds, Series 2001 (the "Series 2001 Bonds") of which amount \$76,950,000 is issued and outstanding as of the date hereof; and

WHEREAS the University has authorized the issuance pursuant to the 1999 General Bond Resolution, the Resolution adopted by the Board on November 2, 2001 (the "Series D Commercial Paper Resolution") the Indenture and Series D Supplement to the Amended and Restated Trust Indenture, dated as of December 1, 2001 (the "Series D Supplement") between the University and the Trustee, \$175,000,000 The Ohio State University General Receipts Commercial Paper Notes, Series D (the "Series D Notes" of which amount \$60,700,000 is issued and outstanding as of the date hereof; and

WHEREAS the University has authorized the issuance pursuant to the 1999 General Bond Resolution, the Resolution adopted by the Board on November 2, 2001 (the "Series 2002 A General Receipts Bond Resolution"), the Indenture and the Series 2002 A Supplement to Amended and Restated Trust Indenture, dated as of January 1, 2002 (the "Series 2002 A Supplement") between the University and the Trustee, \$150,515,000 The Ohio State University General Receipts Bonds, Series 2002 A (the "Series 2002 A Bonds"), of which amount \$145,075,000 is issued and outstanding as of the date hereof; and

WHEREAS the University has authorized the issuance pursuant to the 1999 General Bond Resolution, the Resolution adopted by the Board on February 7, 2003 (the "Series 2003 A General Receipts Bond Resolution"), the Indenture and the Series 2003 A Supplement to Amended and Restated Trust Indenture, dated as of February 1, 2003 (the "Series 2003 A Supplement") between the University and the Trustee, \$53,000,000 The Ohio State University General Receipts Bonds, Series 2003 A (the "Series 2003 A Bonds"), of which amount \$50,965,000 is issued and outstanding as of the date hereof; and

WHEREAS the Board has determined that it is in the best interests of the University to authorize the issuance of The Ohio State University General Receipts Commercial Paper Notes, Series E (the "Series E Notes") in the principal amount not to exceed \$430,000,000 for the purpose of paying or reimbursing a portion of the costs of the Series E Project, currently refunding certain outstanding Obligations and paying costs and expenses associated with the issuance of the Series E Notes; and

WHEREAS the University desires to make provisions for the issuance of the Series E Notes and for the payment of the Debt Service Charges thereon and the securing thereof by this Resolution and a Series E Supplement to Amended and Restated Trust Indenture (the "Series E Supplement") herein authorized.

NOW THEREFORE

BE IT RESOLVED BY THE BOARD OF TRUSTEES OF THE OHIO STATE UNIVERSITY as follows:

**AUTHORIZATION, ISSUANCE AND SALE OF
GENERAL RECEIPTS COMMERCIAL PAPER NOTES, SERIES E, OF
THE OHIO STATE UNIVERSITY (contd)**

Section 1. Definitions and Interpretations. All words and terms defined in the Original Indenture and all interpretations therein provided shall have in this Resolution the same meanings, respectively, and be subject to the same interpretations as therein provided or used, unless the context or use clearly indicates another or different meaning or intent. Terms not appearing in the Original Indenture but used herein and not previously defined herein are defined as follows:

"Book Entry System" means a system under which (i) a physical Series E Note certificate in fully registered form is issued for each maturity of Series E Notes only to a Depository or its nominee as registered owner, with the Series E Notes held by and immobilized in the custody of the Depository; and (ii) a book entry record, maintained by and the responsibility of the Depository and not maintained by or the responsibility of the University or the Trustee, is the record that identifies, and records the transfer of the interests of, the owners of book entry interests in such Series E Notes.

"Costs of Issuance Account" means the Costs of Issuance Account in the Note Program Fund created pursuant to Section 5 hereof.

"Dealer" or "Dealers" means J.P. Morgan Securities Inc. or any successor or assigns permitted under the Dealer Agreement, and any other dealer or dealers for the Series E Notes which is appointed by the University and has entered into a Dealer Agreement.

"Dealer Agreement" or "Dealer Agreements" means respectively, the Dealer Agreement, by and between the University and J.P. Morgan Securities Inc., and any and all modifications, alterations, amendments and supplements thereto, and such agreement and any other Dealer Agreement entered into by the University and a Dealer or Dealers with respect to the Series E Notes.

"Depository" means any securities depository that is a clearing agency under federal law operating and maintaining, with its participants or otherwise, a Book Entry System to record ownership of book entry interests in obligations, and includes and means initially as to the Series E Notes, The Depository Trust Company (a limited purpose trust company), New York, New York.

"Note Proceedings" means the 1999 General Bond Resolution, the Amended and Restated Indenture, any applicable Series Resolution, any applicable Supplemental Indenture and any other resolutions and agreements and amendments of and supplements to the foregoing, or any combination thereof, authorizing or providing for the terms and conditions applicable to, or providing for the security or sale of Notes, and the terms contained in such Notes.

"Note Program Fund" means the Note Program Fund held by the University and created in Section 5 hereof to be funded with the proceeds of the Series E Notes.

"Offering Memorandum" means, as to the Series E Notes, the Offering Memorandum relating to the original issuance of the Series E Notes, authorized pursuant to Section 3 hereof.

"Project Account" means the Project Account in the Note Program Fund created pursuant to Section 5 hereof.

"Series E Commercial Paper Resolution" or "this Resolution" as used herein means this Resolution, as the same may be amended from time to time.

"Series E Project" means the Series E Project as described on Attachment I to the Series D Supplement, which exhibit is incorporated by reference herein with the same force and effect as if fully set forth herein.

**AUTHORIZATION, ISSUANCE AND SALE OF
GENERAL RECEIPTS COMMERCIAL PAPER NOTES, SERIES E, OF
THE OHIO STATE UNIVERSITY (contd)**

"Trustee" means The Huntington National Bank, and any successor Trustee as determined or designated under or pursuant to the Original Indenture.

Any reference herein to the University, the Board, or to any members or officers thereof or to other public boards, commissions, departments, institutions, agencies, bodies, entities or officers, shall include those which succeed to their functions, duties or responsibilities pursuant to or by operation of law or who are lawfully performing their functions. Any reference to a section or provision of the Ohio Revised Code or to the laws of Ohio shall include such section or provision and such laws as from time to time amended, modified, revised, supplemented, or superseded, provided that no such amendment, modification, revision, supplementation, or supersession shall alter the obligation to pay the Debt Service Charges in the amount and manner, at the times, and from the sources provided in the 1999 General Bond Resolution, this Resolution, the Amended and Restated Trust Indenture and the Series E Supplement, except as otherwise herein permitted.

Unless the context shall otherwise indicate, words importing the singular number shall include the plural number, and vice versa, and the terms "hereof," "herein," "hereby," "hereto," "hereunder," and similar terms, mean this Resolution.

Section 2. Authorization; Terms; Pledge; and Covenant.

(a) Authorization. The Bonds, to be designated and known as The Ohio State University General Receipts Commercial Paper Notes, Series E, shall be issued pursuant to and as authorized by the Act, Section 2i of Article VIII of the Ohio Constitution, the 1999 General Bond Resolution, this Resolution, the Amended and Restated Trust Indenture and the Series E Supplement for the purposes of financing a portion of the costs of the University Facilities comprising the Series E Project, currently refunding certain outstanding Obligations and paying costs and expenses incidental to the issuance of the Series E Notes. The Series E Notes shall be issued from time to time as provided in the Series E Supplement to finance and refinance the cost of the Series E Project. Proceeds of the Series E Notes may also be used to pay maturing Series E Notes.

(b) Form and Numbering. The Series E Notes shall be issued only as fully registered Bonds. The Series E Notes shall be numbered as determined by the Trustee.

(c) Denominations and Dates. The Notes shall be dated the date of their respective authentication and issuance; shall be issued in registered form, registered to bearer (subject to Section 2.06 of the Series E Supplement) unless otherwise designated by a Dealer; and shall be issued in denominations of \$100,000 and in integral multiples of \$1,000 in excess thereof.

(d) Principal Amount. The Series E Notes shall be issued in the principal amount specified in the Series E Supplement, which amount shall not exceed \$430,000,000.

(e) Delivery and Execution. The Treasurer is hereby authorized to make the necessary arrangements with the Dealer to establish the date, location, procedures and conditions for the delivery of the Series E Notes to the Dealer and to take all steps as necessary to effect due execution, authentication and delivery of the Series E Notes to the Dealer or to the persons whom the Dealer directs under the terms of this Resolution. The Series E Notes shall be signed by the Treasurer in his official capacity (provided that such signature may be a facsimile) and may bear the corporate seal of the University or a facsimile thereof.

(f) Interest. The Series E Notes shall bear interest from their respective dates, payable at maturity, at a rate not to exceed 12% per annum (calculated on the basis of a year consisting of 365/366 days and actual number of days elapsed).

**AUTHORIZATION, ISSUANCE AND SALE OF
GENERAL RECEIPTS COMMERCIAL PAPER NOTES, SERIES E, OF
THE OHIO STATE UNIVERSITY (contd)**

(g) Maturities. The Series E Notes (i) shall mature not more than 270 days after their respective dates, but in no event later than December 15, 2004, and (ii) shall mature on a Business Day. The stated interest rate, maturity date and other terms of each Note, so long as not inconsistent with the terms of the Series E Supplement, shall be as set forth in the Instructions delivered to the Trustee pursuant to Section 2.07 of the Series E Supplement.

(h) Redemption. The Series E Notes shall not be subject to redemption prior to their stated maturities.

(i) Appointment of Dealer. The Board hereby appoints J.P. Morgan Securities Inc. as the initial Dealer for the Series E Notes.

(j) Security. As provided in the Indenture, there is hereby pledged to the security of the Series E Notes, (i) the gross amount of General Receipts of the University (subject to the provisions for the partial release of a pledge of General Receipts contained in Section 4.10 of the Amended and Restated Trust Indenture) and (ii) the moneys contained in the Special Funds. Anything else to the contrary in the Indenture, the 1999 General Bond Resolution, the Series E Supplement or this Resolution notwithstanding, the Series E Notes shall not have access to, any claim upon or be secured by, the Bond Reserve Fund or the Note Program Fund. This pledge of General Receipts shall be on parity with expenses, claims and payments relating to other Parity Obligations (as defined in the Original Indenture) and in priority to all other expenses, claims and payments of the University. In accordance with the Act, all the General Receipts or portions thereof are immediately subject to the lien of the pledge upon receipt thereof by the University; provided, however, the lien of such pledge shall not attach to any Series E Notes the proceeds of which are to be used to provide the Series E Project until the Board of Regents of the State shall have approved such pledge.

For the further security of the Series E Notes, and any Obligations, the University hereby covenants with the bondholders and the Trustee that so long as any Series E Notes or Obligations are outstanding, the University shall fix, make, adjust and collect fees, rates, rentals, charges, and other items of General Receipts, as will produce at all times General Receipts sufficient (i) to pay Debt Service Charges when due, (ii) together with other moneys lawfully available therefor, to pay all costs and expenses required to be paid under the Note Proceedings, and (iii) together with other moneys lawfully available therefor, to pay all other costs and expenses necessary for the proper maintenance and successful and continuous operation of the University.

(k) Payment, Places of Payment, and Paying Agents . The principal of and interest on the Series E Notes shall be paid in federal or other immediately available funds in such coin or currency of the United States of America as, at the respective times of payment, is legal tender for the payment of public and private debts. The principal of and interest on the Series E Notes shall be payable at the principal office of the Trustee on or before the close of business on any Business Day upon which such Series E Notes have become due and payable, provided that such Series E Notes are presented and surrendered on a timely basis. Upon presentation of such a Series E Note to the Trustee no later than 3:00 p.m. (Columbus, Ohio time) on a Business Day, payment for such Series E Note shall be made by the Trustee in immediately available funds on such Business Day. If a Series E Note is presented for payment after 3:00 p.m. (Columbus, Ohio time) on a Business Day, payment therefor shall be made by the Trustee on the next succeeding Business Day, without the accrual of additional interest thereon.

(l) Book Entry. Subject to the provisions of the immediately following paragraph, the Series E Notes shall be issued only to a Depository for holding in a Book Entry System in accordance with the provisions of Section 2.06 of the Series E Supplement. Those Series E Notes shall be registered in the name of the Depository or its nominee, as registered owner, and immobilized in the custody of the Depository; and shall not be transferable or exchangeable, except for transfer to another Depository or to another nominee of a Depository, without further

**AUTHORIZATION, ISSUANCE AND SALE OF
GENERAL RECEIPTS COMMERCIAL PAPER NOTES, SERIES E, OF
THE OHIO STATE UNIVERSITY (contd)**

action by the University. Each maturity of the Series E Notes shall be evidenced by a single certificate in the aggregate principal amount of the Series E Notes maturing on such maturity date.

If any Depository determines not to continue to act as a Depository for the Series E Notes for holding in a Book Entry System, the University may attempt to have established a securities depository/Book Entry System relationship with another qualified Depository. If the University does not or is unable to do so, the University, after making provision for notification of the owners of book entry interests by appropriate notice to the then Depository and any other arrangements it deems necessary, shall permit the withdrawal of the Series E Notes from the Depository, and authenticate and deliver the Series E Note certificates, in fully registered form to the assigns of the Depository or its nominee (if such Bond was held by a nominee), all at the cost and expense (including costs of printing or otherwise preparing and delivering replacement Series E Notes) of the Bondholders.

Section 3. Offering Memorandum. It is determined hereby that the manner of sale and the terms of the Series E Notes, as provided in this Resolution and the Series E Supplement, are consistent with all legal requirements and will carry out the public purposes of the Act.

The use and distribution of the Offering Memorandum relating to the Series E Notes substantially in the form now on file with the Board by the Dealer is hereby approved and authorized. The Board has not confirmed, and assumes no responsibility for, the accuracy, sufficiency or fairness of any statements in the Offering Memorandum contained in Appendix B thereto.

Section 4. Allocation of Proceeds. The proceeds from the sale of the Series E Notes, including any accrued interest, shall be allocated, deposited and applied as follows:

- (i) To the Bond Fund, accrued interest, if any, received on the sale of the Series E Notes; and
- (ii) To the Note Program Fund, created pursuant to Section 5 of this Resolution, the entire remaining amount of the proceeds of the Series C Notes, to be applied to the purposes of that Fund, including transfers from that Fund authorized by the Act and to pay costs and expenses associated with the issuance of the Series E Notes.

Section 5. Note Program Fund. There is hereby created by the a fund to be maintained in the custody of the Treasurer and designated the "Note Program Fund." The Note Program Fund shall be funded from the proceeds of the sale of the Series E Notes. Such proceeds shall be used for the payment or reimbursement of a portion of the costs and expenses relating to the Series E Project and costs and expenses associated with the issuance of the Series E Notes. The Note Program Fund shall not constitute a Special Fund and shall not be pledged to the payment of Debt Service Charges.

Moneys held in the Note Program Fund, including all investment earnings thereon, pending disbursement from the Note Program Fund shall be invested in Authorized Investments specified in Section VIII of the Non-Endowment Investments Policy of the University, as the same may be amended from time to time. The University may establish such accounts in the Note Program Fund as are necessary or desirable to carry out the requirements of the Series E Supplement.

The Treasurer shall maintain such books and records with respect to disbursements from the Note Program Fund so as to enable the Treasurer to determine the name of any payee of any such disbursement, the date on which such disbursement occurred, the amount of such disbursement and the purpose for which such disbursement was made. Investment earnings on the funds on deposit in the Note Program Fund may, at the discretion of the University, be paid to

**AUTHORIZATION, ISSUANCE AND SALE OF
GENERAL RECEIPTS COMMERCIAL PAPER NOTES, SERIES E, OF
THE OHIO STATE UNIVERSITY (contd)**

the Trustee for deposit in the Bond Service Account in the Bond Fund to be used to pay Debt Service Charges on the Series E Notes.

There shall be established in the Note Program Fund the following accounts:

(i) The Costs of Issuance Account, from which shall be paid the costs of issuance of the Series E Notes;

(ii) The Redemption Account, from which shall be disbursed such portion of the proceeds as shall be necessary to retire such portion of the General Receipts Commercial Paper Notes, Series C and

(iii) The Project Account, from which shall be disbursed such portion of the proceeds of the Series E Notes necessary to pay costs of the Series E Project, currently refunding certain outstanding Obligations and paying costs and expenses associated with the issuance of the Series E Notes. The Treasurer shall designate in writing, either in the Series E Supplement or otherwise, the allocation of the proceeds of the Series E Notes to each of the foregoing accounts.

Upon the determination by the Treasurer that the costs incurred in connection with any item listed in Section 1 hereof in the definition of Series E Project (each a "Component") to be paid from the Note Program Fund have been paid in full or provision for such payment has been made, the University may use any remaining moneys on deposit in the Note Program Fund with respect to such Component to fund the costs of other Components or to fund the costs of additional projects constituting University Facilities (each, an "Additional Project"). Moneys remaining on deposit in the Note Program Fund after the completion of the Series E Project and any Additional Projects shall be used by the University in any manner which, in the opinion of Bond Counsel, shall be permissible under the Act and the Code.

Section 6. Application of Bond Proceeds. The University covenants that the use of the proceeds of the Series E Notes will be restricted in such manner and to such extent, if any, as may be necessary, after taking into account reasonable expectations at the time of delivery of and payment for the Series E Notes, so that the Series E Notes will not constitute "arbitrage bonds" under Sections 103(c) and 148 of the Code. The Treasurer of the University, or any other officer having responsibility with respect to the issuance of the Series E Notes, alone or in conjunction with any other officer or employee of or consultant to the University, will give an appropriate certificate of the University for inclusion in the transcript of proceedings for the Series E Notes setting forth the reasonable expectations of the University regarding the amount and use of those proceeds and the facts and estimates on which they are based, all as of the date of original delivery of and payment for the Series E Notes.

The University further covenants that it will take all actions required to maintain the exclusion from gross income for purposes of federal income taxation of interest on the Series E Notes and will not take or permit to be taken, any actions which would adversely affect such exclusion under the provisions of the Code that apply to the Series E Notes; and the Chairman or the Treasurer and other appropriate officers are hereby authorized to take such actions and give such certifications as may be appropriate to assure such exclusion from gross income of interest on the Series E Notes.

Section 7. Series E Supplement and Other Documents. In order to better secure the payment of the Debt Service Charges as the same shall become due and payable, the Chairman, the President of the University, the Secretary of the Board and the Treasurer, or any one or more of them, are authorized and directed to execute, acknowledge and deliver to the Trustee and the Dealer, in the name and on behalf of the University and pursuant to the Indenture, the Series E Supplement and the Dealer Agreement, respectively, each in substantially the form submitted to this Board, or to such officers on behalf of this Board and the University, and such documents are hereby approved, with such changes therein as are not

**AUTHORIZATION, ISSUANCE AND SALE OF
GENERAL RECEIPTS COMMERCIAL PAPER NOTES, SERIES E, OF
THE OHIO STATE UNIVERSITY (contd)**

substantially adverse to the University and as may be permitted by the Act and approved by the officers executing the same on behalf of the University. The Series E Supplement shall also include the form of the Series E Notes (the "Form of Note"), attached thereto as Exhibit A. The execution of such documents by any of the officers shall conclusively evidence that the officers and the Board approve such changes and that such changes are not substantially adverse to the University.

Each of such officers is further authorized to execute and deliver on behalf of the University such other certificates, documents and instruments as are necessary in connection with the acts authorized by this Resolution.

Section 8. Open Meeting Determination. It is found and determined that all formal actions of the Board concerning and relating to the adoption of this Resolution were adopted in an open meeting of the Board, and that all deliberations of the Board and of any of its committees that resulted in such formal action were in meetings open to the public, in compliance with all legal requirements including Section 121.22 of the Ohio Revised Code.

Section 9. Effective Date. This Resolution shall take effect and be in force immediately upon its adoption.

Upon motion of Mr. McFerson, seconded by Ms. Hendricks, the Board of Trustees adopted the foregoing resolution with eight affirmative votes, cast by Messrs. Sofia, Slane, McFerson, O'Dell, and Judge Duncan, Meses. Longaberger, Hendricks, and Davidson, and one abstention cast by Mr. Borrer.

--0--

Mr. Sofia:

Today we enjoyed hearing from this year's University Distinguished Professors who make us proud to be part of this wonderful University.

Again, we would like to welcome our new Board members, Wally O'Dell and Emily Quick, and I know they'll make many contributions to this University.

--0--

Thereupon the Board adjourned to meet Friday, July 11, 2003, at The Ohio State University Longaberger Alumni House, Columbus, Ohio.

Attest:

David O. Frantz
Secretary

Zuheir Sofia
Chairman

(APPENDIX LII)

**Federation of the Colleges of the Arts and Sciences
at The Ohio State University
May 2003**

Edward J. Ray
Executive Vice President and Provost

Karen A. Holbrook
President

Background

Universities often engage in administrative changes in which they disassemble existing structures or consolidate currently separate programs. There is no simple blueprint for accomplishing either. Meeting strategic goals, and increasing efficiencies or improving function, provide a rationale for such changes. Timing is often a motivating factor. The Ohio State University, within the framework provided by the Academic Plan, has been deliberating a consolidation in administrative structure of the arts and sciences - at a time when excellence and advancement within the arts and sciences require the strength of the whole.

Since 1968, the Colleges of Arts and Sciences at The Ohio State University have existed as five independent colleges: Arts, Biological Sciences, Humanities, Mathematical and Physical Sciences (MAPS), and Social and Behavioral Sciences (SBS). All are led by deans, two of whom (MAPS and SBS) soon will be retiring. One of the five deans, currently the Dean of Humanities, also serves as Executive Dean of the five colleges. The role of the Executive Dean is to coordinate discussions among the five deans regarding policy issues facing the university; to serve on the Council of Deans' Steering Committee; and to oversee the newly consolidated arts and sciences development staff. The Executive Dean has no administrative support, other than an executive assistant and associate executive dean (part-time).

The question has been raised as to whether the existing structure is optimal in assuring that this core element of the university - the arts and sciences - is as strong and productive as it can be, or as lean and efficient as it needs to be in this era of budget constraints, and whether it provides the right configuration for growth, serves students to greatest advantage and, as one colleague asked, "promotes excellence, intellectual breadth, and innovation."

In February 2002, an ad-hoc committee that included one senior faculty member from each of the arts and sciences colleges (recommended by the college dean), and chaired, initially, by former President Edward H. Jennings, was appointed by the Provost and charged to provide specific recommendations for strengthening the arts and sciences at The Ohio State University. The committee's report (Appendix A) was completed early in October 2002, under the direction of Professor Joseph Ferrar, and contained a set of recommendations for the optimal configuration and the authority of the Executive Dean of the Arts and Sciences. The report was submitted to appropriate University Senate committees and the faculty and staff in the arts and sciences, with a request for comments by early December 2002. The Provost, and members of the committee, met with numerous groups and held two open forums for the arts and sciences faculty and staff.

On January 16, 2003, as part of his annual speech to the University Senate, the Provost proposed a plan (Appendix B) for the administrative operations of the Colleges of the Arts and Sciences. It included a number of changes from the recommendations proposed by the committee, reflecting a consideration of the discussions and written recommendations that had been received. The University community was asked to respond to this plan by March 14, 2003. Discussions then were held in the University Senate Steering Committee, Fiscal Committee, Rules Committee, and the Faculty Council, and by two discussion panels at University Senate meetings. Additional comments were also received from a number of groups and individuals. All of this input enlightened the thinking regarding the plan and provided a strong sense of faculty ideas and concerns on the topic. Much of the commentary dealt with the broad question of

whether or not the arts and sciences should become a federation; however a number of helpful questions, concerns, and suggestions were expressed that have informed changes in the proposed administrative structure of the federation.

We believe The Ohio State University would benefit substantially from a coherent, collaborative, and financially sound core of arts and sciences programs of the highest possible quality. Every university in the top tier of public teaching and research universities has strong arts and sciences at its core. Our Academic Plan demands strength in this critical area. If we maximize the synergies that exist among the programs in the five separate colleges of the arts and sciences, we can enhance the availability of interdisciplinary courses, sequences, minors, and majors available to undergraduate and graduate students, and build upon existing interdisciplinary academic program offerings in the arts and sciences. We can more effectively create collaborative interdisciplinary clusters of teachers and scholars across the arts and sciences. We can initiate more teaching, research, and service collaborations within the university and with external partners that draw upon our strengths across the arts and sciences.

The remainder of this document provides a rationale and goals for a federation of the colleges of the arts and sciences, and with regard to implementation, it specifies roles and responsibilities for a newly-defined Executive Dean position and the deans of the five colleges and outlines financial arrangements.

The Federation of the Colleges of the Arts and Sciences

Rationale and Goals

Some steps have already been taken to rearrange the arts and sciences colleges into a federation. The Development staff, for example, serves the five colleges individually and collaborates on behalf of all of the arts and sciences; the deans of the arts and sciences have begun to develop a strategic plan for the arts and sciences and to solicit faculty and staff recommendations; and the arts and sciences deans have been asked to build upon the curriculum review efforts of the Undergraduate Curriculum Review Committee (March 2003). However, beyond these recent changes the present structure has been characterized, by a significant number of arts and sciences faculty, as having rigid boundaries and displaying college-centric competitive behavior. Currently, intellectually indefensible barriers stand in the way of program development, cross-college curricula, joint hires, and the collaboration and creation of a collective strength that could accrue with greater coordination and interaction.

The following goals exist for establishing a tighter union of the arts and sciences colleges:

- Elevate the stature and visibility of the arts and sciences internally, nationally, and internationally;
- Enhance the reputation and quality of all colleges by using the strengths of each to benefit others via new programs;
- Enhance coherence, collaboration and synergies;
- Bolster and assess efforts in enhancing diversity of faculty, staff, and students;
- Reduce administrative costs so that resources conserved could be invested in new faculty positions, support services for students, and advance most of the other goals of the Academic Plan;
- Strengthen advising and career counseling;
- Improve joint hiring and cluster hiring;
- Promote new curricula;
- Strengthen the presence of Ohio State arts and sciences within organizations such as the Association of American Universities (AAU) and the National Association of State Universities and Land Grant Colleges (NASULGC);
- Decrease wasteful college-centric competition and lower college boundaries; and

- Benefit undergraduate and graduate student interdisciplinary study and research opportunities.

Integration does not need to reduce the significant role of individual deans and can expand their portfolio of responsibilities. Maintaining the appropriate balance between autonomy and the integration of these deans' responsibilities will be a charge to the new Executive Dean.

Implementation: Structure

The effective and efficient advancement of the arts and sciences within the University, and on behalf of the University, will require a clear understanding of the roles and responsibilities of the Executive Dean, the dean of each of the five colleges, and the faculty within the arts and sciences. A clearly defined division of labor must be articulated for the key offices within the federation to ensure that academic initiatives are developed, managed, and advanced as seamlessly as possible and that associated services and administrative oversight are provided efficiently, by eliminating duplicative efforts.

Executive Dean of the Colleges of the Arts and Sciences

The new federation would benefit from a different configuration of leadership in which the Executive Dean does not also hold the deanship of one of the colleges. Such a change would remove a potential conflict of interest for the Executive Dean. Therefore, the current position of the Executive Dean of the Colleges of the Arts and Sciences will be made a separate position from that of the five deans of the colleges of the arts and sciences, and a separate Office of the Executive Dean of the Colleges of the Arts and Sciences will be established effective July 1, 2003. The term of the Executive Dean will be converted to five years. An Interim Dean of the College of Humanities will be named after consultation with the faculty, staff, and students of the College of Humanities to serve beginning July 1, 2003. A search will commence for a new dean of the College of Humanities.

Roles of the Executive Dean

The Executive Dean of the Colleges of the Arts and Sciences will serve in the following roles:

- Conditional on a University rules change, the Executive Dean will advise the Provost on appointment, tenure and promotion decisions in the arts and sciences. Dossiers will be sent by the college deans to the Office of Academic Affairs. The Provost will seek advice from the Executive Dean in any case in which the Provost believes that the perspective of the arts and sciences collectively would be useful to the Provost in reviewing the case.
- Advise the Provost regarding the base budgets and re-basing allocation schedules for the five arts and sciences colleges. He/she will distribute these funds to the five colleges, subject to review by the Provost. The college deans will be responsible for the day-to-day management of their funds, subject to review by the Executive Dean;
- Allocate common funds, defined below, within the arts and sciences, in consultation with the five deans, and /or committees created to make program recommendations;
- Promote interdisciplinary undergraduate and graduate programs and research excellence within and across college boundaries;
- Promote diversity among faculty, staff, undergraduate, and graduate students and in all programs throughout the arts and sciences;
- Lead the faculty of arts and sciences in re-thinking the proper organizational structure for curricular development; this may or may not lead to a revised

committee pattern, but the emphasis should be on enabling curricular improvement and cooperation across the five colleges;

- Develop and implement a strategic plan for the arts and sciences, in consultation with the five deans and appropriate representative bodies in the colleges of the arts and sciences, and ensure that the plan is discussed broadly before it is finalized;
- Develop a pattern of administration document for the arts and sciences, in consultation with the faculty of the arts and sciences, to be reviewed and approved by the Office of Academic Affairs. As with all such documents, the pattern is to be reviewed and revised, as necessary, within one year of the appointment or reappointment of an Executive Dean;
- Provide administrative oversight for development activities and communications in the arts and sciences;
- Collaborate with Undergraduate Student Academic Services (USAS) in the oversight of academic advising and career counseling services and in the recruitment of undergraduate students in the arts and sciences;
- Require the realization of economies of scale from enhanced collaboration regarding the provision of services such as personnel and fiscal services common to all arts and sciences colleges;
- Oversee the effective administration of the collaborative and distributed elements of the Arts and Sciences Honors and Scholars Program;
- Oversee the management of the University Press;
- Oversee interdisciplinary academic programs that draw faculty expertise from more than one college among the arts and sciences such as, but not limited to, the Undergraduate International Studies Program, the Asian American Studies, Latino/a Studies, and Disability Studies undergraduate minors, as well as course sequences that draw from more than one college such as the American Sign Language sequence. Changes in current reporting lines for these programs will be determined in consultation with the five deans and the Provost;
- Select the chair, in consultation with the Provost, for the search committees for the five college deans, advise the Provost on the selection of other committee members, and on the appointment of all deans, and work with the Provost on the annual evaluation of these deans. The deans of the five colleges, together with the Executive Dean, will serve on the Council of Deans;
- The Executive Dean will share his/her Annual Report with the University Senate Fiscal Committee.

Responsibilities of the Executive Dean

The responsibilities of the position are different from the roles of the Executive Dean. The success of the federation will depend substantially on the respect commanded by the Executive Dean and the extent to which he/she exhibits the leadership and collaborative qualities that the new organization will require. Specifically, the Executive Dean has the responsibility to:

- Work with the five college deans to assure that there is continuous and expeditious communication of arts and sciences issues. One of the first responsibilities the Executive Dean will spearhead with his/her colleagues will be to develop specific plans to create a federation management structure that will reduce existing overlapping and extraneous administrative structures among the five colleges. It is recognized that this cannot occur immediately, but action should be as expeditious as possible;
- Demonstrate an understanding of all aspects of the arts and sciences and pursue opportunities to promote collaboration within the arts and sciences and on behalf of elements of arts and sciences with other programs across the University and across the country.

- Work to assure department chairs are part of and involved in the federated colleges;
- Promote a faculty culture of federation in addition to discipline specific alliances;
- Define opportunities for attracting new financial resources for the federation. The funding offered by the Provost described below should be viewed as a start-up investment or challenge funding to attract new resources from external sources;

Reporting Relationships

The Executive Dean is appointed to a five-year renewable term, subject to acceptable annual reviews by the Provost and a satisfactory formal performance review in the fourth year. The Executive Dean reports to the Provost.

The College Deans

There will be a dean for each of the five colleges of the arts and sciences.

Roles of the College Deans

The Deans of the five colleges of the arts and sciences will:

- Manage their budgets according to the budget restructuring policies developed within their colleges and approved by the Office of Academic Affairs, subject to the review of the Executive Dean;
- Provide college leadership for the recruitment and retention of high quality faculty and send tenure and promotion cases directly to the Office of Academic Affairs for University level review;
- Provide college level leadership in the efficient organization and management of programs, including the appointment and re-appointment of department chairpersons and directors of schools;
- Provide college level leadership for the creation and expansion of new programs and the consolidation and elimination, as appropriate, of existing programs;
- Advance the quality, diversity, and substance of college teaching, research, and service opportunities for faculty, staff and students, through collaborative contributions to the effective management of the federation; and
- Serve on the Council of Deans and be evaluated by the Provost and the Executive Dean.

Responsibilities of the Deans

The responsibilities of the Deans of the Arts and Sciences within the context of the federation are to:

- Work with the Executive Dean to develop plans that streamline the administrative structure within the federation and facilitate the communication of information regarding the arts and sciences within their own colleges, departments and schools;
- Encourage and facilitate the involvement of department chairs and school directors in federation activities;
- Encourage and facilitate a faculty culture of federation, as appropriate;
- Contribute to collaborative planning and activities that can enhance external funding of activities and programs that reach across the arts and sciences.

Reporting Relationships of the Deans

Each college dean is appointed to a five-year renewable term, subject to acceptable annual reviews by the Executive Dean and the Provost, and periodic formal review as provided in Board by-law 3335-1-19 (R). For matters relating to the "roles" of the Executive Dean, the college deans report to the Provost through the Executive Dean.

The Faculty of the Colleges of the Arts and Sciences

The structure and the leadership of the federation of the arts and sciences still have issues that need resolution with input from the coordinated arts and sciences faculty. Some of these issues include:

- Creation of new resources beyond institutionally assigned resources;
- Function and streamlining of a central curriculum committee;
- Research investment;
- Compatibilities of budget restructuring under a federation model; and
- Re-alignment of reporting lines for existing cross-disciplinary programs – including guidelines and criteria for centralization versus college oversight of such programs

The Executive Dean working with the five deans and the faculty of the arts and sciences should review the current governance structure for the arts and sciences, with a goal of establishing task forces or committees, as appropriate, to work quickly and make progress on such issues.

A formal review of this administrative structure will commence in the fourth year

Implementation: Financial Arrangements

1. The Office of Academic Affairs will provide continuing funding to cover the staffing and operating costs of the Office of the Executive Dean.
2. The Executive Dean, in consultation with the five deans of the arts and sciences, will be charged with streamlining administrative costs among the five colleges and distributing the resulting savings among the colleges primarily for interdisciplinary faculty and program enhancement purposes. This process is expected to be continuous but within three years there should be savings of at least \$500,000 in continuing administrative costs. The annual evaluation of the Executive Dean and each of the Deans of the Arts and Sciences and formal reviews for renewal of their appointments will include an assessment of the contribution that each has made to streamlining administrative costs in the arts and sciences administrative structure and to redirecting resources to faculty and staff recruitment and retention, student support, and program needs within the arts and sciences. Consistent with our institutional commitment to excellence through diversity, these resources should be used to enhance the diversity of our faculty, staff, students, and program offerings throughout the arts and sciences.

During the first year of operation, the Office of the Executive Dean should develop metrics to demonstrate cost reductions and efficiencies in the provision of administrative services among the five college and executive dean offices that will be updated and reviewed annually as part of the performance review of each of the college deans and the Executive Dean.

While it is always a matter of both art and science to make comparisons of administrative staffing for academic units across time and across institutions, it is instructive to compare the administrative staffing of the arts and sciences at Ohio State in 1992 and 2002 and to compare the current administrative staffing of the arts and sciences at Ohio State with staffing at other universities, including several of our benchmark peers. Table I compares

the number of executive staff and other staff affiliated with the college offices among the colleges of the arts and sciences at Ohio State with the arts and sciences staffing at other major universities. The ratios of faculty to executive staff across institutions and of faculty to other staff suggest that economies of scale and scope in administering to the needs of the arts and sciences faculty through a coordinated federation of colleges could result in substantial cost savings.

Table I

If we define executive staff to include deans, associate deans, and the principal fiscal and/or personnel officers in the college offices the following comparative data for Autumn 2002 are instructive:

	#College Office		# Arts & Sciences Faculty	Ratio of A&S Faculty to College Office	
	Exec Staff	Other Staff		Exec Staff	Other Staff
University of California at Los Angeles	7	28.4	850	121:1	30:1
University of Illinois at Urbana/Champaign	6	7	620	103:1	89:1
University of Iowa	5	16	630	126:1	39:1
University of Washington	6	18	890	148:1	49:1
University of Wisconsin	7.25	30	908	125:1	30:1
The Ohio State University - Sept 2002	23	31	1004	44:1	32:1

The other staff category consists of non-executive staff assigned to the functions currently performed in Ohio State's five college offices: faculty matters, curriculum processes, and fiscal and personnel issues.

These data suggest that a number of our benchmark peers do manage to have excellent arts and sciences core programs with relatively lean administrative structures. The Executive Dean and the Deans of the Colleges of the Arts and Sciences should be held to a comparably high standard of administrative efficiency in the performance of their duties.

In addition to the comparative data for administrative costs in the arts and sciences across some of our benchmark institutions, it is instructive to review the growth in administrative staffing for the combined college offices within the arts and sciences over the last ten years. As indicated in Table II below, the number of executive staff and total staff positions for the five college offices has increased from 21 to 26.6 and from 59 to 76, while the number of FTE faculty has declined slightly from 985 to 954. The combined cost of executive staff positions alone is now equal to \$3,408,000. This is not a trend that can be sustained in the face of the financial challenges facing the University.

Table II

	College Executive Staff FTE		Total College Staff FTE		Tenure/Tenure Track Faculty FTE		Ratio of Faculty FTE to Executive Staff FTE		Ratio of Faculty FTE to College Total Staff FTE	
	AU92	AU02	AU92	AU02	AU92	AU02	AU92	AU02	AU92	AU02
ART	6.00	5.00	17.50	18.60	142.10	142.45	23.68	28.49	8.12	7.66
BIO	3.41	3.30	9.41	13.13	85.84	89.10	25.17	27.00	9.12	6.79
HUM	4.60	6.90	17.10	23.90	304.60	298.30	66.22	43.23	17.81	12.48
MPS	3.00	5.90	8.00	10.90	237.12	210.55	79.04	35.69	29.64	19.32
SBS	4.00	5.50	7.10	9.50	215.40	213.35	53.85	38.79	30.34	22.46
TOTAL	21.01	26.60	59.11	76.03	985.06	953.75	46.89	35.86	16.66	12.54

Executive Staff for 1992 includes Deans, Assc/Asst Deans and the following staff: Conti, Riechel, Wernet, Tomei, Dantuono, Newman, Krygier, and Conrad. Decision rule for other staff inclusion as Executive Staff is 1) college administrative staff; 2) salary > \$40,000 (salary of lowest paid asst/assc dean); and 3) not computing staff

Executive Staff for 2002 includes Deans, Assc/Asst Deans and the following staff: Miller, Riechel, Tomei, Dantuono, Newman, Naber, Krygier, Vonville, and Conrad. Decision rule for other staff inclusion as Executive Staff is 1) college administrative staff; 2) salary > \$53,750 (\$40,000 increased 3% each year); and 3) not computing staff

Total College Staff FTE does not include staff assigned to college office fiscal numbers but employed in the Melton Center for Jewish Studies, the Council of Colleges of Arts & Sciences, the Hopkins Hall Gallery, The Robert Shaw Institute, or as Biological Sciences Laboratory support staff.

Data Source: Office of Human Resources Management Information and Analysis Reporting

3. The Office of Academic Affairs will provide the Office of the Executive Dean with \$500,000 in cash for each of the next three years to seed program initiatives that should be funded long-term through reductions in the administrative costs for the five colleges. The effectiveness of those allocations will be reviewed annually as part of the general University budget process.
4. Administrative cost reductions among the five colleges in excess of \$500,000 or the costs associated with the Office of the Executive Dean, whichever is greater, will be matched by continuing central investment funds up to a total of \$500,000 for distribution by the Executive Dean in consultation with the five deans. In effect, these additional central funds will be made available only if the combined administrative costs for the Executive Dean and the five colleges are less than the current costs of administrative services in the five colleges.

5. Given the central role of the arts and sciences in the successful implementation of the Academic Plan, it is expected that the Office of Academic Affairs will provide periodic cash and continuing funds in support of collaborative initiatives within the arts and sciences through the Office of the Executive Dean. At the same time, interdisciplinary innovation and fundamental contributions to knowledge are often the products of collaboration among excellent disciplinary programs. Central investments, including all competitive awards, will continue to flow directly to disciplines and colleges within the arts and sciences as appropriate and without regard to any allocations targeted for the arts and sciences as a whole through the Office of the Executive Dean.
6. The five percent University strategic investment tax on marginal income from tuition and the state share of instruction will continue. There will be an additional three percent internal reallocation of the marginal growth of tuition and the state share of instruction revenues within the arts and sciences. This internal reallocation at the discretion of the Executive Dean, in consultation with the five Deans, will be used primarily to promote collaborative hires, programs, course offerings, and research initiatives. Based upon marginal income gains for FY03, the three percent internal reallocation would yield at least \$650,000 per year. The three percent internal reallocation should be reviewed after several years to determine if it is sufficient to meet the needs and opportunities for collaboration within the arts and sciences. The authority to change the common pool for internal reallocation purposes resides with the Provost.

Conclusion

After more than a year of planning and deliberation, with arguments from all perspectives presented and considered, we believe that a Federation of Colleges of Arts and Sciences with a newly-defined Executive Dean position is needed and have determined that it will now be established. The advancement of The Ohio State University, clearly laid out in the Academic Plan, demands excellence from the Arts and Sciences. Indeed our students deserve no less. The timing is appropriate. The budget situation underscores the need for strategic decisions to streamline, add efficiencies, and reduce duplication. Within the arts and sciences, working together in a coordinated, consolidated way on programmatic issues will help us move in this direction more easily. Creating the Federation of the Colleges of Arts and Sciences is an opportunity for the faculty to use their talent, expertise, and broad networks to be creative and innovative, and to use this basic plan to help make arts and sciences a central and pivotal element of the academic excellence and advancement of The Ohio State University.

**The Ohio State University Board of Trustees
Fiscal Affairs Committee**

May 2, 2002

TOPIC: Revised Transportation and Parking Regulations

CONTEXT:

The University's Transportation and Parking Regulations were last updated in June 10, 1982. To ensure that these regulations reflect today's needs, Transportation and Parking Services is proposing a number of revisions. Most of the revisions are stylistic or updates to policies that have changed over time. A summary of the substantive changes is shown on Attachment A.

In addition, Transportation and Parking Services is recommending two changes to current policy: first, to immobilize or "boot" vehicles as a preliminary step before vehicle impound; second to streamline the appeals process for faculty staff and visitors. Details of these recommendations are shown on Attachments B and C.

These changes have been reviewed by the Coordinating Council, Office of Legal Affairs, the Council on the Physical Environment, Council of Graduate Students, Inter-Professional Council, Undergraduate Student Government, and the University Staff Advisory Committee.

RECOMMENDATION:

Approve the revisions for submission to the Office of the Ohio Secretary of State and incorporation into the Ohio Administrative Code.

ISSUES:

On-going challenge of managing pedestrian and vehicular movement on campus.

REQUESTED OF BOARD OF TRUSTEES:

Adoption of the revised regulations.

Office of Business and Finance
Business Operations
Transportation and Parking Services
April 7, 2003



December 2, 2002

ATTACHMENT A

MEMORANDUM

TO: Bill Shkurti
FROM: Helen DeSantis
Sarah Blouch
SUBJECT: Revisions to Transportation & Parking Regulations

Attached is an updated version of the Transportation and Parking Regulations. Most of the revisions are stylistic, housekeeping changes, or updates to policies that have been implemented over time. (Regulations were last updated in May 1982.) Legal Affairs and the Office of Public Safety have approved the draft document as submitted. A summary of the most substantive changes follow.

Page 5-Chapter 2, Section Q	Reference to Hospital Security Staff "working" accidents. Staff no longer perform this function.
Page 12-Chapter 4, Section E	Reference to 90-day limit for regulations created to handle special conditions deleted. Special situations sometimes last a year or longer before outcome (effectiveness of rule change can be measured).
Page 18-Chapter 6, Section F	Existing policy for motorcycle parking shown.
Page 19-Chapter 6, Sections L and M	Reference to Ramp, Validation, Car Pool and Surface permits eliminated. These permit types were replaced with the transferable permit system.
Page 19-Chapter 6, New Section L	Existing policy for distribution of media permits through the Office of University Relations shown. Reference to "no ticket policy" deleted.
Page 23-Chapter 7, Section B (9)	Limit for violations before impounding changed from 3 delinquent tickets to \$50.00. Customer feedback (particularly students) indicated \$50.00 ceiling preferred -- 3 tickets could be easily total \$100.00 and pose a bigger financial (and emotional) challenge for customers.
Page 23-Chapter 7, Section D	T&P practice of entering an impounded vehicle to remove a parking permit that has been altered, stolen or forged for evidence required by OSUPD has been added.
Page 24-Chapter 8, Section C	Window for appeal extended from 5 days to 15 days to allow customer sufficient time to respond.
Page 54-Chapter 18, Section O	Regulation change for roller skates and similar device approved by the Board of Trustees in Autumn Quarter 1998.
Page 61-Chapter 20, Section E (2)	Current parking permit designations shown.

Also included in this document are two changes in policy/process for consideration:

- Page 23-Chapter 7, Section C
This section was added to support a new service being recommended. A "boot" or wheel immobilizer would be placed on the tire instead of towing the vehicle.
- Page 27-Chapter 9, Section A (1, 2)
Streamline the 2nd Level Appeals process for Faculty/Staff and create a 2nd Level Appeals process for visitors.

Details of these policy changes are shown on the following pages.

Immobilizing Vehicles Subject to Impound

General Information

- Vehicles with \$50 accumulated citation fines that have not been paid or appealed are subject to impound.
- 900 vehicles on average are impounded each year.

CURRENT PROCESS
<ul style="list-style-type: none"> • If fines are not paid within 48 hours, the vehicle is impounded and held until fines are paid. • \$60 tow fee is added to the amount of the unpaid fine (\$45 is paid to the towing company; T&P receives \$15). • Over 90% of the customers pay fines within 24 hours after vehicles are towed. <p>DRAWBACKS:</p> <ul style="list-style-type: none"> • Customer does not know whereabouts of vehicle when s/he returns to parking space. • Customers must travel to impound lot on Kenny Road to retrieve personal belongings from towed vehicle. • Time consuming for T&P officer who waits for tow truck, monitors process and often transports customers to impound lot for immediate access to personal belongings (45 minutes on average). • Risk of damage claims to towed vehicle.

RECOMMENDED CHANGE
<ul style="list-style-type: none"> • If customer does not pay fine within 48 hours a boot (wheel immobilizer) is placed on vehicle. • \$30.00 boot fee is added to the amount of the unpaid fine. Boot remains on vehicle until fine is paid, but not more than 24 hours. • After 24 hours vehicle is towed. Tow fee is charged in lieu of boot fee. <p>BENEFITS:</p> <ul style="list-style-type: none"> • Less anxiety for customers—vehicle is not missing from parking space. • Less frustration for customers – personal belongings can be immediately retrieved from vehicle. • Officer's time is reduced to less than 20 minutes and can be re-directed to more productive tasks. • Fewer damage claims expected. • Less costly for most customers. • Approximately \$12,000 new revenue to T&P annually. Initial cost for "boots" is \$5,000.

APPEALS PROCESS

Approximately 80,000 parking citations are issued annually. Of the citations issued, about 10,000 (or 8%) are appealed through a 1st Level Appeals process. Less than 1% of the first level decisions are elevated by customers to the second level. The process to respond to 1st and 2nd level appeals has evolved over time and some components no longer mirror the Transportation and Parking Regulations (last updated May 1982). Following is a summary of the current process as well as some recommended changes.

<p>CURRENT PROCESS Student appeals</p>	<p>CURRENT PROCESS Faculty/Staff appeals</p>	<p>CURRENT PROCESS Visitor appeals</p>
<p>1st Level Appeals: T&P Administrative Assistant reviews appeal to determine if the citation should be dismissed modified or upheld. A written determination is sent to the appellant. Subsequent questions from the appellant are researched and resolved by T&P administration prior to the 2nd level appeals process.</p> <p>2nd Level Appeals: The Office of Student Advocacy reviews and makes determination.</p> <p>Benefits: 1st Level Appeals</p> <ul style="list-style-type: none"> • T&P Administrative Assistant has knowledge base to make informed decisions. • Timely response to customers —5 work days on average. <p>Drawbacks: 1st and 2nd Level Appeals Processes have evolved and are not consistent with T&P Regulations.</p>	<p>1st Level Appeals:</p> <p>Same</p> <p>2nd Level Appeals: Reviewed by committee of 2 faculty, 2 staff members and 1 graduate student. Customers have not requested 2nd level appeal since 2001.</p> <p>Benefits: 1st Level Appeals</p> <ul style="list-style-type: none"> • Same • Same <p>2nd Level Appeals</p> <ul style="list-style-type: none"> • Process is consistent with T&P Regulations. <p>Drawbacks: 1st Level Appeals</p> <ul style="list-style-type: none"> • Process has evolved and is not consistent with T&P Regulations. <p>2nd Level Appeals</p> <ul style="list-style-type: none"> • Inefficient use of committee 	<p>1st Level Appeals:</p> <p>Same</p> <p>2nd Level Appeals: No formal 2nd level appeals process exists.</p> <p>Benefits: 1st Level Appeals</p> <ul style="list-style-type: none"> • Same • Same <p>2nd Level Appeals</p> <ul style="list-style-type: none"> • Process is consistent with T&P Regulations. <p>Drawbacks: 2nd Level Appeals</p> <ul style="list-style-type: none"> • Process to hear 2nd Level Appeals not currently in place.

PROPOSED CHANGE FROM CURRENT PROCESS

<p><u>Student Appeals</u></p> <ul style="list-style-type: none"> • None <p>Faculty/Staff Appeals</p> <ul style="list-style-type: none"> • 1st level – none • 2nd level – adjudication by Legal Affairs’ representative rather than committee. <p>Visitor Appeals</p> <ul style="list-style-type: none"> • 1st level – none • 2nd level – establish process for Legal Affairs to adjudicate appeals
--

Chapter 3335-21
The Ohio State University
Traffic Transportation and Parking Regulations Rules

3335-21-01 General Provisions.

- (A) Title; references. These rules shall be known and may be cited as the Ohio state university traffic transportation and parking regulations rules, or just the “university ~~traffic regulations transportation rules~~”. ~~Reference~~ References throughout these rules to “~~these regulations rules~~” shall be deemed to mean and include all of the provisions of the these Ohio state university traffic transportation and parking regulations rules.
- (B) Authority; repeal of previous rules. These rules, governing traffic and parking upon the streets and roadways, property and grounds of the university, are enacted pursuant to authority vested in the board of trustees by Chapters 3335 and 3345 of the Revised Code. All previous rules and regulations of the board pertaining to traffic and parking are hereby repealed.
- (C) Application of regulations; collection of assessments; incorporation of state law. These rules constitute a dual system of enforcement of traffic laws and rules and regulations. They are enforceable by contract against faculty, students, employees and agents of the university, as well as visitors to the university. Such assessments ~~which are made under this rule~~ these rules are enforceable by civil action against a violator in any court of competent jurisdiction. Incorporated by reference into these rules are all state laws, when applicable, which are enforceable against any person, including the above specified persons, in any court of competent jurisdiction, pursuant to; the authority conferred upon the board of trustees by Chapters 3335 and 3345 of the Revised Code.
- (D) Certification and publication of rules. The secretary of the board of trustees shall certify the passage of these rules and cause the same to be published for public distribution in a manner reasonably designed to come to the attention of, and be made available to; all faculty, staff, students, and ~~visitors, and students.~~
- (E) Effective date. These rules shall take effect from and after the date of their approval by the board of trustees.
- (F) Separability. If any part of these rules is, for any reason, held to be invalid, such decision shall not affect the validity of the remaining parts of these rules.

3335-21-02 ~~Definition of words and phrases~~ Definitions.

As used in these rules, the following words and phrases shall, for the purpose of these rules, have the meanings respectively ascribed to them in this chapter.

- (A) and (B) unchanged.
- (C) “Assessment” means the sum exacted of faculty, employees, students, visitors and agents for violation of any of the provisions of these rules, which sum constitutes the liquidated damages for violation of the contract existing by and between the university and its faculty, employees, students, visitors and agents. Assessments are established by ~~the division of traffic transportation and parking services~~, approved by the senior vice president for business and finance of the university and adopted by the board of trustees.
- (D) “Authorized emergency vehicle” or “emergency vehicle” means emergency vehicles of the university, municipal, township, or county departments or public utility corporations when identified as such as required by law, the Ohio director of highway public safety, or local authorities, and motor vehicles when commandeered by a police officer as set forth in division (D) of section 4511.01 of the Revised Code.

- (E) "Bicycle"; means every device, other than a tricycle designed solely for use as a play vehicle by a child, propelled solely by human power, upon which any person may ride, having either two tandem wheels or one wheel in the front and two wheels in the rear, any of which is more than fourteen inches in diameter as set forth in division (G) of section 4511.01 of the Revised Code.
- (F) Unchanged.
- (G) "Bus" means every motor vehicle designed for carrying more than nine passengers and used for the transportation of persons, other than a ride sharing arrangement, and every other motor vehicle, automobile for hire or funeral car, other than a taxicab or motor vehicle used in a ride sharing arrangement, designed and used for the transportation of persons for compensation as set forth in division (L) of section 4511.01 of the Revised Code.
- (H) and (I) unchanged.
- (J) "Crosswalk" means:
- (1) That part of a roadway at intersections ordinarily included within the real or projected prolongation of property lines and curb lines and/or, in the absence of curbs, the edges of the traversable roadway;
 - (2) Unchanged.
 - (3) Notwithstanding paragraphs (J)(1) and (J)(2) of this rule, there shall not be a crosswalk where authorized local authorities have placed signs ~~have been placed~~ indicating no crossing as set forth in division (LL) of section 4511.01 of the Revised Code.
- (K) "Curb loading zone" means a space adjacent to a curb, which ~~space~~ is reserved for the exclusive use of vehicles during loading or unloading.
- (L) ~~"Division of traffic~~ Department of transportation and parking services" means the ~~division of traffic transportation and parking services department~~ of the university.
- (M) "Director" means the director of transportation and parking services.
- ~~(M)~~(N) "Driver" means any person who drives or is in actual physical control of a vehicle as set forth in division (Y) of section 4511.01 of the Revised Code.
- ~~(N)~~(O) "Fee" means a sum extracted of faculty, ~~employees~~ staff, students, ~~visitors~~ visitors and agents for ~~deals, permits, Keycards~~ keycards, parking meters, and pay parking facilities, parking fines or services. Fees are established by ~~the division of traffic transportation and parking services~~, approved by the senior vice president for business and finance of the university and adopted by the board of trustees.
- ~~(O)~~(P) "Grounds" means all lands belonging to the university or over which the university may have control.
- ~~(P)~~(Q) "Hospital safety and campus security officer" means an employee of the ~~division~~ department of hospital safety and security or campus security who, when authorized by the ~~manager~~ director of ~~the division of traffic transportation and parking services~~ or public safety, may perform one or more of the following duties:
- (1) Unchanged.
 - (2) Investigate traffic accidents;
 - ~~(3)~~(2) Enforce all provisions of these rules pertaining to parking; or

~~(4)~~(3) Enforce rules for bicycles.

~~(Q)~~(R) "Intersection" means:

(1) The "Intersection" means the area embraced within the prolongation or connection of the lateral curb lines or, if none, then the lateral boundary lines of the roadways of two highways which join one another at, or approximately at, right angles, or the area within which vehicles traveling upon different highways joining at any other angle may come in conflict.

(2) Unchanged.

~~(3)~~ The junction of an alley with a street or highway, or with another alley, shall not constitute an intersection as set forth in division (KK) of section 4511.01 of the Revised Code.

~~(R)~~(S) "Laned street or roadway" means a street highway or roadway which is divided into two or more clearly marked lanes for vehicular traffic as set forth in division (GG) of section 4511.01 of the Revised Code.

~~(S)~~(T) Unchanged.

~~(F)~~(U) "Loading zone" means a space or spaces adjacent to a building, which space or spaces are designated for the exclusive use of vehicles during loading or unloading.

~~(U)~~ "Manager" means the manager of the ~~division of traffic and parking.~~

(V) "Motor vehicle" means every vehicle propelled or drawn by power other than muscular power, or power collected from overhead electric trolley wires, except motorized bicycles, road rollers, traction engines, power shovels, power cranes and/or other equipment used in construction work and not designed for or employed in the general highway transportation, hole-digging machinery, ditch-digging machinery, well-drilling machinery, farm machinery, trailers used to transport agricultural produce or agricultural production materials between a local place of storage or supply and the farm when drawn or towed on a public street or highway at a speed of twenty-five miles per hour or less, threshing machinery, hay-baling machinery, and agricultural tractors and machinery used in the production of horticultural, floricultural, agricultural and vegetable products and trailers designed exclusively to transport a boat between a place of storage and a marina, or in and around a marina, when drawn or towed on a street or highway for a distance of no more than ten miles at a speed of twenty-five miles per hour or less as set forth in division (B) of section 4511.01 of the Revised Code.

(W) "Motorcycle" means every motor vehicle, other than a tractor, having a saddle for the use of the operator and designed to travel on not more than three wheels in contact with the ground, including, but not limited to, motor vehicles known as "motor-driven cycle," "motor scooter" or "motorcycle" without regard to weight or brake horsepower as set forth in division (C) of section 4511.01 of the Revised Code

(X) "Motorized bicycle" means a any vehicle having either two tandem wheels or one wheel in the front and two wheels in the rear, that is capable of being pedaled and is equipped with a helper motor of not more than fifty cubic centimeters piston displacement which that produces no more than one brake horsepower and is capable of propelling the vehicle at a speed of no greater than twenty miles per hour on a level surface as set forth in division (H) of section 4511.01 of the Revised Code.

(Y) Unchanged.

(Z) "Official time standard" means Eastern Standard Time or Eastern Daylight Savings Time, whichever is in effect at the time and in the general area in question ~~in the general area.~~

(AA) and (BB) unchanged.

(CC) "Park" and "parking" mean the standing of a vehicle, whether occupied or not, ~~other than temporarily for the purpose of and~~ except while actually engaged in loading or unloading merchandise or passengers.

(DD) "Parking area" means any portion of the land and property of the university which is designated for the parking of vehicles. The term includes parking lots and parking ~~ramps~~ garages.

(EE) "Parking zone" means any portion of university streets or roadways, parking areas, parking lots or parking ~~ramps~~ garages on which the parking of vehicles may be permitted or regulated by the University.

(FF) Unchanged.

(GG) "Pedestrian" means any natural person afoot as set forth in division (X) of section 4511.01 of the Revised Code.

(HH) "Person" means a natural person, firm, copartnership, association, or corporation as set forth in division (W) of section 4511.01 of the Revised Code.

(II) "Public safety vehicle" means any of the following:

(1) Ambulances, including private ambulance companies under contract to the university or to a municipal corporation, township or county, and private ambulances and non-transport vehicles bearing license plates issued under section 4503.49 of the Revised Code;

(2) Motor vehicles used by public law enforcement officers, traffic ~~and parking control~~ officers, hospital ~~safety~~ and campus security officers, or other persons sworn to enforce the criminal and traffic laws of the state;

(3) Any motor vehicle when properly identified as required by the Ohio director of highway public safety, when used in response to fire emergency calls or to provide emergency medical service to ill or injured persons, and when operated by a duly qualified person who is a member of a volunteer rescue service or a volunteer fire department; and who is on duty pursuant to the rules or directives of that service. The state fire marshal shall be designated by the Ohio director of ~~highway~~ public safety as the certifying agency for all public safety vehicles described in this paragraph.

(4) Vehicles used by fire departments, including motor vehicles when ~~not~~ used by volunteer ~~firemen~~ firefighters responding to emergency calls in the fire department service when identified as required by the Ohio director of ~~highway~~ public safety.

~~(5)~~ Any vehicle used to transport or provide emergency medical service to an ill or injured person, when certified as a public safety vehicle, shall be considered a public safety vehicle when transporting an ill or injured person to a hospital regardless of whether such vehicle has already passed a hospital.

(5) Vehicles used by the commercial motor vehicle safety enforcement unit for the enforcement of orders and rules of the public utilities commission as specified in section 5503.34 of the Revised Code and as set forth in division (E) of section 4511.01 of the Revised Code.

(6) Any non-motorized vehicle used for transportation and parking services.

(7) Any motorized or non-motorized vehicle used by the university's public safety department.

(JJ) Unchanged.

- (KK) "Restricted zone" means that any portion of the Columbus campus of the university where the entry of all motor vehicles is controlled.
- (LL) "Right of way" means the right of a vehicle or pedestrian to proceed uninterruptedly in a lawful manner in the direction in which it or ~~he~~ the individual is moving in preference to another vehicle or pedestrian approaching from a different direction into its or his the individual's path as set forth in division (UU) of section 4511.01 of the Revised Code.
- (MM) through (NN) unchanged.
- (OO) "Rules" means the ~~traffic~~ transportation and parking rules of the Ohio state university.
- (PP) "Safety zone" means the area or space officially set apart within a roadway for the exclusive use of pedestrians and protected or marked or indicated by adequate signs as to be plainly visible at all times as set forth in division (MM) of section 4511.01 of the Revised Code.
- (QQ) "Sidewalk" means ~~the paved walk for pedestrians at the side that portion of a street or between the curb lines or the lateral lines of a roadway and the adjacent property lines intended for the use of pedestrians as set forth in division (FF) of section 4511.01 of the Revised Code.~~
- (RR) through (UU) unchanged.
- (VV) "Street" or "highway" means the entire width between the boundary lines of every way open to the use of the public as a thoroughfare for purposes of vehicular travel as set forth in division (BB) of section 4511.01 of the Revised Code.
- (WW) "Student traffic ~~controller~~ officer" means a student who has been hired by ~~the manager of the division of traffic transportation and parking services or the chief of university police~~ to assist with traffic control upon any university property or roadway.
- (XX) Unchanged.
- (YY) "Traffic" means pedestrians, ridden or herded animals, vehicles and other devices, either singly or together, while using any roadway for purposes of travel as set forth in division (TT) of section 4511.01 of the Revised Code.
- (ZZ) "Traffic and parking control officer" means an employee of ~~the division of traffic transportation and parking services~~ authorized by the ~~manager~~ director of ~~the division transportation and parking services~~ to perform one or more of the following duties:
- (1) Direct, regulate or supervise traffic;
 - (2) Investigate traffic accidents;
 - (3) Enforce all provisions of these ~~regulations~~ rules pertaining to parking; or
 - (4) Enforce ~~regulations~~ rules for bicycles, skateboards and roller blades.
- (AAA) "Traffic control device" means all flaggers, a sign signs, signal signals, marking or device markings and devices placed or erected by authority of a public body or official having jurisdiction for the purpose of ~~regulations~~ regulating, warning or guiding traffic; including signs denoting the names of streets; ~~erected by the authority of the Division of Traffic and Parking and highways as set forth in division (QQ) of section 4511.01 of the Revised Code.~~
- (BBB) "Traffic control signal" means any device, whether manually, electrically or mechanically operated, by which traffic is alternately directed to stop, to proceed, to change direction or not to change direction as set forth in division (RR) of section 4511.01 of the Revised Code.

(CCC) through (EEE) unchanged.

(FFF) "Vehicle" means every device, including a motorized bicycle, in, upon, or by which any person or property may be transported or drawn upon a street or roadway, except devices motorized wheelchairs, other than bicycles moved by human power as set forth in division (A) of section 4511.01 of the Revised Code.

(GGG) Unchanged.

(HHH) "Visitor" means any person who is not either a faculty member, a staff member, an employee, or a student, a contractor, or a vendor of the university.

3335-21-03 Traffic Transportation and parking administration services.

(A) Establishment. There is hereby established within the ~~Department of University Public Safety a Division of Traffic~~ office of business and finance the department of transportation and parking services.

(B) General functions. ~~The division of traffic~~ Transportation and parking services shall coordinate ~~these~~ these rules, develop ways and means to improve traffic conditions in conjunction with the department of public safety and carry out the specific functions set forth in these rules. Such specific functions include, but are not limited to, the following:

(1) Maintenance of a current journal of all official traffic control devices erected on university streets, roadways, grounds and properties, indicating the location, and the date of erection ~~and the regulation imposed;~~

(2) Unchanged.

(3) Regulation of traffic by means of enforcement personnel of the ~~division~~ department and traffic control devices or, when necessary, with the assistance of law enforcement officers of the university or other agencies, and hospital ~~safety~~ and campus security officers, on streets, roadways, land and property of the university on which traffic may be permitted;

(4) Regulation or prohibition of processions on the parts of streets, roadways, land and property of the university ~~on~~ upon which traffic may be permitted;

(5) and (6) unchanged.

(7) Regulation of the stopping, standing and parking of vehicles on streets, roadways, land and property of the university on which traffic may or may not be permitted.

(C) Installation of traffic devices. It shall be the general function of the ~~division~~ department to determine the installation and proper timing and maintenance of traffic control devices, to conduct engineering analyses of traffic accidents and to devise remedial measures for the same, to conduct engineering investigations of traffic conditions, to plan the operation of traffic on the streets, roadways and lands of the university and to cooperate with other university officials in the development of ways and means to improve traffic conditions.

3335-21-04 Administration of violations.

~~The division of traffic~~ Transportation and parking services shall be responsible for the administrative processing of all traffic tickets or notices of violations.

(A) Records of violations:

(1) All records of violations shall be serially numbered, with date and time.

- (2) ~~The division of traffic Transportation and parking services shall maintain records of all violations of these rules, together with a record of assessments and collections and the final disposition of all such alleged violations. Such records shall be so maintained as to show all types of violations and the total of each. Such records shall accumulate during at least a four year period and from that time forward, or the issuance of new license plates be maintained in accordance with University archive policies.~~
- (B) ~~All forms for records of violations and notices of violations shall be serially numbered. For each month and year a written record shall be kept available to the public showing the disposal of all such forms.~~
- (G)(B) ~~Investigation of accidents.~~ Traffic and parking control officers shall investigate traffic accidents, shall request university police assistance, if needed for such accident investigations, and shall assist other university officials in enforcing these rules against violators causing or contributing to such accidents.
- (D)(C) ~~Accident studies.~~ Whenever the accidents at any particular location become numerous, the division of traffic transportation and parking services, in conjunction with the department of public safety, shall conduct studies of such accidents and determine remedial measures.
- (E)(D) ~~Accident reports.~~ The chief of university University police shall maintain all accident reports taken on university property. Such reports shall be maintained and filed in a manner authorized by the chief of police.
- (E) Emergency and experimental rules:
- (1) Transportation and parking services is hereby authorized to make effective the provisions of these rules and to make and enforce experimental rules to cover emergencies or special conditions.
- (2) Transportation and parking services may test traffic control devices under actual conditions of traffic.
- (F) Annual report. The ~~division of traffic and parking~~ department of public safety shall annually prepare a traffic report which shall be filed with the office of business and finance of the university. Such report shall contain information on university traffic matters, as follows:
- (1) and (2) unchanged.
- (3) The plans and recommendations of the ~~division~~ department for future traffic safety activities.
- (G) Emergency and experimental rules:
- (1) ~~The division of traffic and parking is hereby authorized to make effective the provisions of these rules and to make and enforce experimental rules to cover emergencies or special conditions. No such temporary or experimental rule shall remain in effect for more than ninety days.~~
- (2) ~~The division may test traffic control devices under actual conditions of traffic.~~

3335-21-05 Enforcement generally.

- (A) Authority of police security officers and fire officers enforcement personnel.
- (1) Law enforcement officers, hospital safety and campus security officers and traffic and parking control officers shall enforce, to the extent authorized, these rules on university streets, roadways, lands and properties.

- (2) The university police, hospital safety and campus security officers and traffic and parking control officers and ~~student traffic controller~~ are hereby authorized to direct all traffic by voice, hand, or signal in conformity with these rules, provided that in the event of a fire or emergency or to expedite traffic or to safeguard pedestrians, such officers may direct traffic as conditions may require, notwithstanding the provisions of these rules.
- (3) Unchanged.
- (4) Other staff employed by transportation and parking services or public safety may, at times, assist with traffic direction.
- (B) Obedience to enforcement personnel. No person shall willfully fail or refuse to comply with any lawful order or direction of a law enforcement officer, a fire department official, a traffic and parking control officer, a hospital safety and campus security officer or a student traffic controller officer.
- (C) Application of rules to pushcarts and animal riders. Persons propelling pushcarts or riding animals shall obey traffic regulations rules. Every person propelling a pushcart or riding an animal upon a roadway, and every person driving any animal-drawn vehicle, shall be subject to the provisions of these rules that are applicable to the driver of a vehicle, except those provisions which by their nature can have no application.
- (D) Unchanged.
- (E) Assessments for violations. Whoever breaches his or her contract by violating or failing to comply with any of the provisions of these rules is subject to an assessment established by the ~~division of traffic~~ transportation and parking services or university police, approved by the senior vice president for business and finance of the university and adopted by the board of trustees.
- (F) Forms and records of notices of violations violation. ~~The division of traffic~~ Transportation and parking services shall provide computer generated or printed books of "notice of violation" forms for notifying ~~alleged violators to appear at the division offices to answer to charges of violating any of the provisions of these rules~~ individuals of alleged violations and appropriate response to alleged violation options. Such ~~books forms~~ shall include serially numbered sets of notices in a form serial numbers as prescribed by the ~~division~~ department.
- (G) Issue of forms. The ~~division~~ department shall issue such ~~books~~ notice of violation forms to individual members of the ~~division~~ department, hospital safety and campus security officers and university law enforcement officers. The ~~division~~ department shall require and maintain a written receipt for every hand held computer device or book ~~so issued and shall maintain a record of every such book and each set of notices contained therein~~ of forms issued.
- (H) Procedure upon traffic violations. Except when authorized or directed under state statutes to immediately take a person before a magistrate for the violation of any traffic law, a university law enforcement officer who stops a person for a violation of any state statute, other than for the purpose of giving such person a warning notice, and who does not take such person into custody under arrest for a violation of any state statute, may take the name, address and operator's license number of such person, the registered number of the motor vehicle involved, and such other pertinent information that may be necessary, and may issue to such person in ~~writing on a uniform traffic ticket a notice to answer to the charge against such person in a local court of competent jurisdiction at a time not more than five working university days after such alleged violation, which time shall be specified in the notice. The officer, upon issuing such notice, shall allow such person to proceed.~~
- (I) Issuing notice. Except when authorized by a state statute to immediately take a person before a magistrate for a violation of any traffic law, a law enforcement officer who stops a person for a violation of any of the provisions of these rules, other than for the purpose of giving such person

a warning, shall take the name, address and operator's license number of such person, the registration number of the vehicle, the university registration number, and all other information that may be necessary, and may issue to such person a notice of violation of these rules. The officer, upon issuing such notice, shall then permit such person to proceed.

- (J) Disposition and records of traffic citations, warrants and complaints.
- (1) Every law enforcement officer, upon issuing a uniform traffic ticket to ~~all~~ an alleged violator of any provision of a state statute, shall deposit the original and remaining duplicate copies of the notice with his or her immediate superior officer, who shall cause the notice to be delivered to and filed with the local court of competent jurisdiction with the county.
 - (2) Upon the filing of such original notice in court, as specified, such notice may be disposed of consistent with the rules of that court.
 - (3) The ~~manager~~ director of the ~~division of traffic transportation and parking services~~ shall require the return of each ~~traffic citation~~ notice of violation and all copies thereof which have been spoiled or upon which any entry has been made and which have not been issued to an alleged violator.
 - (4) ~~The chief of university~~ University police shall also maintain or cause to be maintained, in connection with every uniform traffic ticket complaint issued by a university ~~police~~ law enforcement officer, a record of the disposition of the charge by the court.
 - (5) ~~The chief of university~~ police shall also maintain or cause to be maintained a record of all warrants issued by a court of competent jurisdiction and of such state traffic law violation charges which are delivered to the university police department for service, and of the final disposition of all such warrants.
- (K) ~~Enforcement procedures:~~ Notice of parking violation. Whenever any vehicle ~~without a driver~~ is found parked or stopped in violation of any of the provisions of these rules, a ~~traffic and parking control~~ officer, a hospital ~~safety~~ and campus security officer or a law enforcement officer finding such vehicle shall take its registration number and may take any other information displayed on the vehicle which may identify its user, and shall conspicuously ~~affix to~~ place on such vehicle or provide to the violator a notice of violation, on a form provided by ~~the division of traffic transportation and parking services~~, for the driver to answer within a time and at a place specified in such notice.
- (L) Noncompliance with notice of parking violation. If a violator of any of the provisions of these rules does not respond as specified on the notice of violation ~~affixed to~~ placed on a vehicle or ~~given~~ provided to the violator within the specified period of time, ~~the division of traffic transportation and parking services~~ may send to the owner of the motor vehicle to which the notice pertains a letter or a copy of the notice of violation informing such owner of the violation and that the assessment is to be paid. In addition, the ~~division~~ department may take whatever other enforcement action it deems appropriate.
- (M) Prima-facie liability for parking violations. Presumption in reference to violation. In any action charging a violation of this rule governing the stopping, standing or parking of a vehicle, ~~it is~~ presumed that the person ~~to whom the decal has been issued has been the operator~~ who has registered such vehicle with the university was the person who parked or placed such vehicle at the point where, and for the time during which, such violation occurred. In ~~case of a~~ the event that the vehicle that ~~no decal has been issued is not registered with the university,~~ the registered owner ~~will be responsible~~ of the vehicle shall be held prima-facie to be the person controlling, parking or otherwise using the vehicle and committing the violation.
- (N) Unchanged.

3335-21-06 Registration of motor vehicles.

- (A) Parking; registration and permit required. No faculty member, staff member, or student shall at any time park a motor vehicle on any street, roadway, land or property of the university without first registering such motor vehicle with the division of traffic transportation and parking services and obtaining a permit therefrom and displaying such permit on the registered vehicle, unless such vehicle is parked in a pay parking facility or a parking area not controlled by the division department. Visitors may park a motor vehicle at parking meters, in pay facilities or by obtaining a permit and paying the prescribed fee. Contractors and vendors shall follow the same registration procedures as faculty, staff and students ~~unless they are parked in an area designated by the division as a construction site.~~
- (B) Application forms; fees. Registration of motor vehicles, as required in this chapter, shall be made using application for parking permit forms prescribed by ~~the division of traffic transportation and parking services.~~ Such application forms shall be accompanied by fees established by the division department, approved by the senior vice president for business and finance of the university and adopted by the board of trustees.
- (C) Unchanged.
- (D) Permits generally. ~~In general, parking~~ Parking permits shall be issued to applicants in accordance with the ~~particular classification of the applicant, criteria and the fee paid and the criteria for such issuance as established by the division of traffic transportation and parking services.~~ Such permits shall be evidenced by an official registration decal or sticker to be placed upon the motor vehicle so registered in accordance with the rules prescribed by the division. Registration is not considered complete until the valid permit or decal or sticker is permanently affixed appropriately displayed on the vehicle according to instructions on the back of the permit or decal or sticker or as otherwise published by the department.
- (E) Fees. Fees shall be charged for motor vehicle permits and collected from the applicant at the time application is made. Funds derived from such fees shall be deposited in a ~~rotary fund~~ established for such purpose and such funds shall be used for establishment and maintenance of traffic controls, facilities for parking and equipment, and for enforcement and personnel, including, but not limited to, the acquisition of permits or decals or stickers, signs and parking meters; construction and maintenance of parking facilities, traffic control devices and other materials and projects for the control of traffic and parking; ~~and the maintenance, repair and extension of existing facilities; and the provision of campus transportation services to facilitate parking and traffic.~~ Such funds shall also be pledged in support of payment of such bonds as may be issued for the aforesaid purposes and for salaries of traffic control and parking personnel. Such fees for the Columbus campus of the Ohio state university shall be as established by the division department, approved by the senior vice president for business and finance and adopted by the board of trustees.
- (F) Motorcycle parking. Motorcycles with Columbus campus "A", "B" or "C" motorcycle permits shall park only in areas designated as two and three-wheeled motor vehicle areas between the hours of ~~seven five~~ a.m. and four p.m., Monday through Friday; ~~only "A" motorcycle permits shall be allowed to park within the controlled zone during such hours.~~ Motorcycles displaying motorcycle permits shall be allowed to park in four-wheeled motor vehicle areas between the hours of four p.m. and two a.m. Monday through Friday, and on weekends beginning at four p.m. Friday through two a.m. Monday, except that certain areas or zones which may be designated as restricted, limited or reserved and signs shall be posted in accordance with paragraph (E)(5) of rule 3335-21-20 of the Administrative Code. ~~Two and three-wheeled motor vehicles may be registered as four-wheeled vehicles upon payment of the full registration assessment for four-wheeled vehicles upon payment of the full registration assessment for four-wheeled vehicles and may park in the appropriate areas.~~
- (G) Reserved lot area permits. A reserved lot area parking privilege may be granted under the rules and procedures established by the division department.

- (H) Additional motor vehicle registration and permits. Faculty, and staff, and students may register and obtain a permit for a second motor vehicle upon meeting specified criteria and upon payment of a fee established by the division department, approved by the senior vice president for business and finance and adopted by the board of trustees.
- (I) Disability permits. Disability permits, allowing the holders thereof to park in areas other than those for which they already hold permits or in which they are already qualified to park under the rules of the division department, may be issued to students, faculty or staff after proof of disability has been established to the satisfaction of the student health center and the office for disability services and certified by a letter to the ~~division of traffic-transportation~~ and parking services. Parking under authority of a disability permit may include on-street parking after two a.m. All vehicles parked in reserved spaces shall display the license number corresponding to the license number on the sign.
- (1) Special parking locations and privileges for the handicapped shall be provided and designated by the division department. Such locations shall be reasonably close to exits, entrances, elevators and ramps garages.
- (2) Unchanged.
- (J) Parking at short courses, workshops, special events and conference meetings. The division department shall establish rules by which arrangements shall be made to provide parking for visitors who are to attend and take part in short courses, workshops, special events and other conference meetings. ~~Such parking shall be at fees established therefor by such rules. Established fees shall be charged for parking.~~ In general, such rules shall provide that individuals or departments or the conference coordinator, at least ten days prior to the commencement of the event, shall notify the division department of the location of the event and the number of persons involved and shall give ~~such~~ other information as requested. Upon receipt of such information, arrangements shall be made to provide parking areas options for the persons participating, and appropriate permits shall be issued designating the area in which those persons may park their vehicles. Any special permits needed for events not outlined in this paragraph must be approved by the director of university public safety transportation and parking services prior to their issuance.
- (K) Retiree ~~decals~~ permits. Retiree parking permits may be issued to eligible retired faculty members and administrative, professional and classified staff who anticipate the need for occasional parking on campus after their retirement. Eligibility, issuance of ~~decals~~ permits and appropriate fees for this program shall be established by the division department, subject to the approval of the senior vice president for business and finance of the university and approved by the board of trustees.
- (L) ~~Ramp and validation decals. Groups of two or more persons each registering a separate vehicle are eligible for a car pool ramp and validation decal. Each car pool group shall be limited to the selection of one ramp location for parking. Vehicles must display both the car pool ramp decal and the validation decal. Such registration shall be accompanied by fees established by the division of traffic and parking, approved by the vice president for business and finance of the university and adopted by the board of trustees.~~
- (M) ~~Car pool surface lot. Groups of two or more persons each registering a separate vehicle are also eligible for a car pool decal which will enable them to park in any "C" zone surface lot. Such registration shall be accompanied by fees established by the division, approved by the vice president for business and finance of the university and adopted by the board of trustees.~~

~~(N)~~(L) Press permits.

- ~~(1)~~ The division of traffic Transportation and parking services has developed a windshield media identification card press parking permit. The sports information director and the communication services director office of university relations shall distribute these cards permits to off-campus news media personnel only and shall provide traffic transportation and parking services with the name, affiliation and license number(s) of persons to whom such cards permits are issued. This card permit will permit allow parking in any authorized parking space as defined on the back of the permit while the news media representative is on official business only.
- ~~(2)~~ Traffic and parking enforcement personnel shall be instructed not to ticket any vehicle displaying this card, or any other clearly marked media vehicle, parked in an authorized parking space. Faculty, staff or students affiliated with the university must also purchase and display a valid university parking permit.
- ~~(3)~~ Citations shall be issued when a vehicle is improperly parked or creating a hazard or the permit is being used improperly.
- ~~(4)~~ Any news media representative who receives a citation while on official business shall send it to either the sports information director or the communication services director. Citations for violations shall be voided only on a case-by-case basis according to regular appeal procedures.
- ~~(5)~~ Media representatives who identify themselves as such will be allowed inside the traffic control area by entering at Seventeenth street and Millikin road.
- ~~(6)~~ The sports information director and the communication services director shall purchase visitor permits for infrequent visitors whose arrival is known about in advance.
- ~~(7)~~(6) The department of communication services office of university relations shall alert media representatives of these procedures.
- ~~(8)~~(7) These permits shall be issued on an annual basis, effective the first day of classes, autumn quarter or as needed to meet short-term needs.

~~(O)~~(M) Expiration of permits. Permits described in this chapter, when issued, shall expire on the first day of classes, autumn quarter, ensuing after issuance as identified on the permit.

- ~~(1)~~ Permit decals, stickers or cards for the current period, when issued, shall be displayed on the motor vehicle for which they are issued in accordance with the rules of the division of traffic and parking and no registrant shall fail to do so.
- ~~(2)~~ If a motor vehicle for which a permit has been issued is transferred, the permit, decal or sticker shall be removed from the vehicle and the remnants presented to the division for issuance of a new decal or sticker for the new vehicle. A fee shall be charged for the replacement decal or sticker. If no such remnants are presented for replacement decals or stickers, the applicant shall sign an affidavit certifying that the previous decals or stickers have been destroyed and shall assume full responsibility for their unauthorized use if found in service. If the applicant neither presents sufficient remnants nor signs the affidavit, the issuance of decals or stickers shall be at the designated rate for original registration

~~(P)~~(N) Display of permits; transfer of vehicles. Permit Permits, decals, stickers or cards for the current period, when are issued, to a specific individual or department, and shall be displayed on the in a motor vehicle for which they are issued and used in accordance with the rules of the division of traffic transportation and parking services and no registrant shall fail to do so.

- (1) Permits - Transportation and parking services shall be notified if new license plates are obtained.
- (2) Decals - If a motor vehicle for which a permit has been issued is transferred, or windshield replaced, the permit, decal or sticker shall be removed from the vehicle and the remnants presented to the division department for issuance of a new decal or sticker for the new vehicle. A fee shall be charged if no such remnants are presented for the replacement decals or stickers, the applicant shall sign must show proof that the decal is unobtainable, and an affidavit shall be signed certifying that the previous decals or stickers have been destroyed and shall assume full responsibility for their unauthorized use if found in service. If the applicant neither presents sufficient remnants nor signs the affidavit cannot show proof that the decals are unobtainable, the issuance of decals or stickers shall be at the designated rate established fee for original registration.

(Q) Unauthorized use.

- (1) Parking in "A" or "B" Spaces. Persons having registered vehicles and displaying "A", "B" or "R" permits or persons having membership in the president's club or being designated an emeritus and having registered vehicles displaying president's club or emeritus decals, respectively, may not allow their registered vehicle to be parked in "A" or "B" parking spaces by any person other than the registrant. The appropriate assessment shall be made for each violation. This rule shall not apply in lots not under the control of the division of traffic and parking or in pay facilities if the full parking fee is paid.
- (2) Unauthorized use of second motor vehicle permits. Any person who has registered two motor vehicles may only park one of such registered motor vehicles with a validation decal in any authorized parking area. The second motor vehicle without a validation decal may be parked in a pay facility only and the registrant thereof may pay the appropriate parking fee. Owners or drivers of motor vehicles driven or parked in violation of this rule shall be assessed the appropriate fee and the second motor vehicle registration privilege may be revoked for one calendar year.

(R) Unauthorized use of key cards.

- (1) The key card is not transferable and is to be used only with vehicles registered with the division and displaying the corresponding university parking decal.
- (2) The key card is the property of the Ohio state university and may be recalled if not used in accordance with University rules.
- (3) A violator of this paragraph shall, for a first offense, receive a citation and be assessed the appropriate fee.
- (4) A second violation will result in an assessment and the loss of decal privileges for the remainder of the academic year.

(O) Unauthorized use of permit. Parking permits are not transferable to other individuals. Persons having registered vehicles and displaying a permit, may not allow their registered vehicle to be parked on campus by any person other than the registrant. The appropriate assessment shall be made for each violation. This rule shall not apply in lots not under the control of transportation and parking services or in pay facilities if the full parking fee is paid. The permit is the property of the Ohio state university and may be recalled if not used in accordance with university rules.

A violator of this paragraph shall, for a first offense, receive a citation and be assessed the appropriate fee. A second violation will result in an assessment and may result in the loss of parking privileges for the remainder of the academic year.

Unauthorized use of decal/key cards. In some cases, parking decals are issued with a separate keycard. When this occurs, the keycard may only be used in conjunction with the decal.

(S)(P) Defacing, reproduction of and use of revoked permits. No person shall deface, reproduce or use a parking permit, decal or sticker contrary to these rules and no person shall use a permit, decal or sticker after the same has been revoked pursuant to these rules.

(T)(Q) Parking of unregistered vehicles. No person who is required to register a motor vehicle and display a parking permit, but who has not so registered, shall park such motor vehicle on any street, roadway, land or property of the university unless parked in a pay facility or at a paid parking meter. Whoever violates this paragraph shall be assessed the appropriate fee, or referred to university authorities for disciplinary action deemed appropriate, or both.

(U)(R) Reserved parking areas. Certain parking areas, by rule of the ~~division of traffic transportation~~ and parking services, may be reserved for parking by faculty and staff members only at all times or at special times. If such rules are promulgated, they shall be effective upon the placement of signs giving notice of such reservation and limitation on parking areas so selected.

(V)(S) Parking reciprocity among campuses.

(1) Parking privileges for motor vehicles registered with the university are reciprocal in comparable areas between all regional campuses of the university when and the Columbus campus only if the current Columbus decal permit is displayed.

(2) All vehicles not displaying current Columbus campus ~~decals~~ permits shall use pay parking facilities exclusively.

(3) The university has delegated the authority to administer, regulate and enforce traffic and parking on each of the university's regional campuses to the dean/director of their campuses. Each regional campus has on file in the office of the ~~manager~~ director of traffic transportation and parking services a copy of its ~~regulations~~ rules as approved by the regional campus dean and director. In addition, these rules are approved by the board of trustees of each technical college sharing a university regional campus.

(W)(T) Visitor parking. All visitors to the campus shall park in pay parking areas designated by the ~~division of traffic transportation~~ and parking services or display a valid visitor parking permit.

3333-21-07 Impounding.

(A) Disabled vehicles obstructing traffic.

(1) University law enforcement officers or officers of the ~~division of traffic transportation~~ and parking services are hereby authorized to remove a vehicle from a street or roadway to the nearest garage or other place of safety when a vehicle upon a street or roadway is so disabled as to constitute an obstruction to traffic and the person in charge of the vehicle is, by reason of injury, incapacitated to such an extent as to be unable to provide for its custody or removal.

(2) When a vehicle, ~~is~~ left unattended upon a street or roadway, has been removed, and the officer knows or is able to ascertain from the registration records in the vehicle the name and address of the owner thereof, ~~such officer~~ transportation and parking services shall immediately give or cause to be given notice ~~in writing~~ to such owner of the ~~fact~~ facts of ~~such~~ the removal, and the reasons therefor, and of the place to which such vehicle has been ~~removed~~ relocated. If any such vehicle is stored in a public garage, a copy of such notice shall be given to the proprietor of such garage.

- (3) Whenever such an officer removes a motor vehicle from a street or roadway under this rule and does not know and is not able to ascertain the name of the owner, or for any other reason is unable to give notice to the owner as hereinbefore provided, and if the vehicle is not returned to the owner within a period of thirty days, then ~~the officer~~ transportation and parking services shall immediately cause the vehicle to be turned over to the sheriff's department for disposition in accordance with state law applicable to abandoned vehicles, as set forth in section 4513.60 et seq. of the Revised Code.
- (B) Other reasons for impounding. In addition to other powers of enforcement, ~~the division of traffic transportation and parking services~~ is hereby authorized and directed to impound any vehicle and hold the same in custody, as designated by the manager director, if such vehicle is:
- (1) through (4) unchanged.
- (5) ~~Alongside or opposite a street excavation or obstruction when~~ In any area where such standing or parking would obstruct construction, traffic, or prevent university services from being conducted;
- (6) and (7) unchanged.
- (8) Parked in an area for which "No Parking--Tow-Away Area" or other restrictive signs or traffic control devices are erected;
- (9) Has ~~three~~ fifty dollars or more in unpaid or unsettled notices of violation issued against it;
- ~~(10) A vehicle registered by a student and permitted to park in a zone "C" parking area but is parked in a zone "A" or zone "B" parking area or in a parking meter zone contrary to these rules; or~~
- ~~(11)~~
- (10) An unauthorized vehicle parked in a space or area reserved for physically handicapped persons with disabilities.
- (11) A vehicle found parking on campus where transportation and parking services has documented and verified information that indicates abuse of a permit or placard has occurred.
- (12) A vehicle parked contrary to these rules.
- (C) Vehicle immobilizing. Depending upon the circumstances, transportation and parking services may elect to immobilize a vehicle in addition to or in lieu of impoundment.
- (D) Entering an impounded vehicle. An officer has the right to enter an impounded vehicle if a lost, stolen, altered, reproduced, forged, or revoked permit is in use, or a state issued disability parking placard is displayed which is not assigned to the driver of said vehicle.
- ~~(E)~~ Charges and assessments. Any vehicle impounded ~~under authority of this chapter~~ shall be subject to towing and storage charges and all outstanding assessments as promulgated by the ~~division of traffic~~ transportation and parking services and approved by the board of trustees.

3335-21-08 Assessments and disciplinary action.

- (A) Option to pay assessment or appeal. Any person receiving a notice of violation of any of the provisions of these rules for which payment of an assessment may be made to ~~the division of traffic transportation and parking services~~ shall have the option of paying such assessment within the time specified in the notice of violation at the office of the ~~division~~ department or appearing at the office of the ~~division~~ department within the time specified in the notice of

violation and making filing a written appeal ~~on the prescribed form~~ for final disposition of the alleged violation in accordance with the appeals procedure provided for in ~~rule 3335-21-09 of the Administrative Code~~ these rules.

- (B) Payment of assessment. The payment of an assessment to the ~~division~~ department shall be deemed an acknowledgement of the breach of contract, and the ~~division~~ department, upon accepting the prescribed assessment, shall issue a receipt to the violator acknowledging payment thereof.
- (C) Failure to pay assessments; revocation of privileges; collection of debt. If a person upon whom a notice of violation is served, or the owner of a vehicle upon which a notice of violation is placed, fails, within ~~five~~ fifteen days after service of such notice, to pay the prescribed assessment or to request an appeal, as provided for in ~~these rules~~ this chapter, or fails to pay the prescribed assessment as affirmed on appeal, ~~the division of traffic transportation and parking services~~ may initiate a procedure to enforce the university's contract with or discipline any student, or to enforce the university's contract with any faculty member, employee or agent of the university, by revoking the ~~driving or parking~~ privileges on campus or by revoking or withholding any of the benefits appertaining to students, employees, faculty or agents by virtue of their relationship with the university. In addition, for any unpaid assessment found to be applicable as liquidated damages to the university, the university may bring suit in any court of competent jurisdiction for the collection of the debt.
- (D) Ultimate disciplinary action. In any event, and in addition to other powers of enforcement, any faculty member, employee, student or agent violating any provision of these rules shall be subject to such disciplinary action by university authorities as may be provided by the "Bylaws of the Board of Trustees," the "Rules of the University Faculty," the "Code of Student Rights and Responsibilities Conduct" or other applicable university rules, as may be deemed appropriate by the disciplinary authorities as provided in such rules. ~~The division of traffic~~ Transportation and parking services is hereby authorized and directed to initiate such disciplinary procedures in cases provided in these rules or in such cases as deemed appropriate under such rules.

3335-21-09 Appeals.

- (A) ~~Composition of the traffic and parking appeals board.~~

~~The traffic and parking appeals board shall consist of five members, as follows: two faculty members, two staff members (administrative and professional and/or classified civil service) and one graduate student, all appointed by the president of the university. All members shall be appointed for a three-year term with the exception of the graduate student member who shall serve for one year. The president shall appoint one of the members of the board to serve as board chairperson. Terms of appointment shall begin in September and appointments shall be staggered so that each September one new member representing the faculty or staff group is appointed.~~

- (B) ~~Procedures of the traffic and parking appeals board.~~

- (1) Quorum. A quorum shall consist of not less than three members of the traffic and parking appeals board.
- (2) Majority Vote. A majority vote of members present shall govern.
- (3) Hearings.
 - (a) ~~The board chairperson, acting as a referee, shall review all appeals filed with the board and determine which appeals shall be referred to the full board and which shall be determined administratively. Appellants may reappeal administrative decisions to the full board.~~

- ~~(b) Appellants are not required to personally appear before the board. However, an appellant who desires to personally present his or her appeal may do so after giving written notice to the board chairperson.~~
- ~~(c) Such hearings are informal in nature and shall be conducted fairly and impartially. The formalities of criminal process are not required.~~
- ~~(d) Information recorded on the notice of violation, information furnished by the appellant in support of the appeal on the appeal form, or in person at a hearing, plus any record of previously appealed citations, shall be the basis for decisions on all appeals.~~
- ~~(e) Decisions of the board are final and shall be reported to the appellant by appropriate entry on the appeal form.~~

~~(C)(A) Filing of appeal; forms appeals. Any person upon whom or upon whose motor vehicle a notice of violation (citation) has been served may, within five fifteen days of such service, elect to appeal such citation by filing an appeal on a form prescribed by the division of traffic with transportation and parking services. The appeal form shall contain, among other things, the identification of the violation notice (citation) and any facts or circumstances relevant to the merits of the appeal.~~

~~(1) Appeals by faculty, staff and graduate student-employees.~~

~~Appeals filed by members of the university faculty and staff and those graduate students who, by reason of employment status with the university, are eligible for and have purchased "B" staff parking permits, shall be considered by the transportation and parking appeals board. First-level appeals. Appellants filing a first-level appeal are not required to personally appear before the appeals administrator. However, an appellant who desires to personally present his or her appeal may do so.~~

~~The appeals administrator will:~~

- ~~(a) Review appeal documents to assess the validity of the citation and/or any extenuating circumstances prohibiting the appellant from complying with the regulations.~~
- ~~(b) Dismiss or modify the citation under appeal, and notify customer (in writing) of the decision if the violation was improperly cited, improperly written, or mitigating factors existed.~~
- ~~(c) Uphold the citation under appeal, and notify customer (in writing) of the decision if the violation was properly cited, properly written and no mitigating factors existed.~~

~~(2) Appeals by other students:~~

~~Appeals filed by university students, other than those graduate students who, by reason of employment status with the university, are eligible for and have purchased "B" staff parking permits, are heard and decided by the university court. See rule 3335-29-04 of the Administrative Code. Second-level appeals. Appeal of a first-level decision must be made in writing to transportation and parking services. The fine shown on the notice of citation must be paid prior to filing a second-level appeal. Supporting documentation must state, in detail, the grounds wherein the appellant believes the first-level decision was in error.~~

~~Second-level appeals for students will be adjudicated by the office of student advocacy or the office of legal affairs for faculty, staff and visitors. These offices will review the~~

supporting documentation and make a determination as to whether the appeal should be upheld, amended or dismissed. Appellants filing a second-level appeal are not required to personally present the appeal but may do so if desired.

(3) Appeals by visitors.

~~Appeals filed by persons who are not students or faculty or staff members shall be considered and decided by the director of university public safety or the manager of the division of traffic and parking under procedures adopted by the director.~~

(D)(B) Disposition of appeals. ~~Upon review and/or hearing, the traffic and parking appeals board, the university student court, the appeals board chairperson, the director of university public safety or the manager of the division of traffic~~ Consistent with the decision of the office of student advocacy or the office of legal affairs, transportation and parking services, shall dispose of the case by:

- (1) Finding that the violation was committed as charged and determining the penalty to be assessed, whereupon the finding and assessment shall be certified to the ~~division~~ department for enforcement in due course;
- (2) Finding that no violation was committed as charged, in which case the notice of violation shall be withdrawn and the ~~division~~ department shall adjust its records to reflect this disposition; or
- (3) Finding that a violation of a provision of these rules has occurred, but that the penalty would should be waived.

3335-21-10 Obstruction and special uses of public ways.

(A) Placing injurious materials or obstruction in streets and roadways.

(1) No person shall place or knowingly drop upon any part of a street or roadway, any tacks, bottles, wire, glass, nails or other articles which may damage or injure any person or vehicle traveling along or upon such street or roadway, ~~except a substance.~~ Materials may be placed upon the street or roadway by proper authority for the repair or construction thereof.

(2) and (3) unchanged.

(4) No person shall place any obstruction in or upon a street or roadway without proper authority as set forth in section 4511.74 of the Revised Code.

(B) Restrictions on motorcycles, motorized bicycles and nonmotorized traffic.

(1) ~~The division of traffic~~ Transportation and parking services is hereby authorized to determine and designate those heavily traveled streets and roadways upon which the use of motorcycles, motorized bicycles, bicycles, horse-drawn vehicles or other nonmotorized traffic is prohibited. The ~~division~~ department shall erect appropriate signs giving notice thereof.

(2) Unchanged.

(C) Restrictions on commercial vehicles. When signs are erected by the ~~division of traffic~~ transportation and parking services giving notice thereof, no person shall operate a commercial vehicle at any time upon any of the streets, roadways or parts of streets or roadways posted except that ~~such vehicles may be operated thereon for the purpose of delivering or picking up materials or merchandise if they are so operated by entering such street or roadway at the~~

~~intersection nearest the destination of the vehicle and proceeding thereon no farther than the nearest intersection thereafter. Where warranted, signs may be posted indicating limited commercial vehicle access.~~

(D) Recreation streets and roadways.

(1) ~~The division of traffic Transportation and parking services is hereby authorized to declare any street or roadway or part thereof to be a recreation street or roadway and to place appropriate signs or devices in such street or roadway indicating and helping to protect the same.~~

(2) Unchanged.

3335-21-11 Traffic control devices.

(A) Authority to install. ~~The division of traffic Transportation and parking services shall place and maintain traffic control signs, signals and devices when and as required under these rules to make effective the provisions of these rules. The ~~division~~ department may place and maintain such additional traffic control devices as may be deemed necessary to regulate traffic and parking under these rules or under state law or to guide or warn traffic.~~

(B) Unchanged.

(C) Obedience to devices. No driver of a vehicle shall fail to obey the instructions of an official traffic control device applicable thereto placed in accordance with the provisions of these rules, unless otherwise directed by a law enforcement officer, traffic and ~~parking control~~ control officer, hospital ~~safety~~ and ~~campus~~ security officer, ~~public safety~~ or ~~transportation and parking personnel~~, or student traffic ~~controller~~ officer, subject to the exceptions granted the driver of an authorized emergency vehicle in these rules.

(D) Signs required for enforcement. No provision of these rules for which signs are required shall be enforced, and no assessment shall be made against an alleged violator if, at the time and place of the alleged violation, an official sign is not in proper position and sufficiently legible to be seen by an ordinarily observant person. Whenever a particular ~~regulation~~ rule does not state that signs are required, such rule shall be effective even though no signs are erected or in place.

(E) Traffic control signal, terms and lights. Whenever traffic is controlled by traffic control signals exhibiting different colored lights, or colored lighted arrows, successively one at a time or in combination, only the colors green, red and yellow shall be used, except for special pedestrian signals carrying a word legend, and such lights shall indicate and apply to drivers of vehicles and to pedestrians as follows:

(1) Green indication.

(a) Unchanged.

(b) Vehicular traffic facing a green arrow signal, shown alone or in combination with another indication, may cautiously enter the intersection only to make the movement indicated by such arrow, or such other movement as is permitted by other indications shown at the same time. Such vehicular traffic shall yield the right of way to pedestrians lawfully ~~within an adjacent crosswalk and to other traffic lawfully~~ using the intersection.

(c) Unless otherwise directed by a pedestrian control signal, as provided in this rule pedestrians facing any green signal, ~~or except when the sole green signal is a turn arrow,~~ may proceed across the roadway within any marked or unmarked crosswalk.

- (2) Unchanged.
- (3) Steady red indication.
 - (a) Unchanged.
 - (b) Unless a sign is in place prohibiting a right turn as provided in paragraph (E)(3)(e) of this rule, vehicular traffic facing a steady red signal ~~on a one-way street that intersects another one-way street on which traffic moves to the left~~ may cautiously enter the intersection to make a left right turn ~~into the one-way street~~ after stopping as required by paragraph (E)(3)(a) of this rule; and yielding the right of way to pedestrians lawfully within an adjacent crosswalk and to other traffic lawfully using the intersection.
 - (c) through (e) unchanged.
- (4) Signals not at intersections. In the event an official traffic control signal is erected and maintained at a place other than an intersection, the provisions of this paragraph shall be applicable except as to those provisions which by their nature can have no application. Any stop required shall be made at a sign or marking on the pavement indicating where the stop shall be made, but in the absence of any such sign or marking the stop shall be made at the signal as set forth in section 4511.13 of the Revised Code.
- (F) Pedestrian control signals. Whenever special pedestrian signals exhibiting the words "walk," "don't walk" or "wait" are in place, such signals shall indicate the following instructions:
 - (1) Unchanged.
 - (2) "Don't walk" or "wait": No pedestrian shall start to cross the roadway in the direction of the signal as set forth in section 4511.14 of the Revised Code.
- (G) Flashing traffic signals. Whenever an illuminated flashing red or yellow traffic signal is used in a traffic signal or with a traffic sign it shall require obedience as follows:
 - (1) Unchanged.
 - (2) Flashing yellow caution signal. Operators of vehicles may proceed through the intersection or past such signal only with caution as set forth in section 4511.15 of the Revised Code.
- (H) Unauthorized signs and signals; hiding from view; advertising.
 - (1) Unchanged.
 - (2) Every such prohibited sign, signal, marking or device is a public nuisance, and the ~~division of traffic~~ transportation and parking services is authorized to remove the same or cause it to be removed as set forth in section 4511.16 of the Revised Code.
- (I) Unchanged.
- (J) Crosswalks and safety zones. ~~The division of traffic~~ Transportation and parking services is hereby authorized to:
 - (1) and (2) unchanged.
- (K) Traffic lanes. ~~The division of traffic~~ Transportation and parking services is hereby authorized to mark traffic lanes upon the roadway of any road or driveway where a regular alignment of traffic

is necessary.

(L) Stop and yield intersections.

(1) Designation of through streets and roadways. Those streets and roadways and parts of streets and roadways designated by ~~the division of traffic transportation~~ transportation and parking services are hereby declared to be through streets and roadways for the purpose of this paragraph when stop or yield signs are erected and maintained by the ~~division~~ department at intersections of such streets and roadways to give preferential right of way to vehicular traffic on the through street and roadway.

(2) Signs required at through streets and roadways. Whenever any regulations rule designates and describes a through street and roadway, the ~~division~~ department shall place and maintain a stop sign or, on the basis of an engineering or traffic investigation at any intersection, a way yield sign, on each and every street and roadway intersecting such through street and roadway unless traffic at any such intersection is controlled at all times by a traffic control signal, provided, however, that at the intersection of two such streets and roadways or at the intersection of a through street and roadway and a heavy traffic street and roadway not so designated, stop signs shall be erected at the approaches of either or both of such streets and roadways as may be determined by the ~~division~~ department upon the basis of an engineering or traffic study.

(3) Signs required at other intersections. The ~~division~~ department is hereby authorized to determine and designate intersections where a particular hazard exists upon other than through streets and roadways and to determine:

(a) and (b) unchanged.

(4) Stop sign and yield sign specifications.

(a) Every stop sign shall bear the word "stop" in letters not less than six inches in height. Every yield sign shall bear the word "yield" in letters not less than seven inches in height. Every stop sign and every yield sign shall, at night, be rendered luminous with an efficient reflecting surface.

(b) Every stop sign and every yield sign shall be erected as near as practical to the nearest line of the crosswalk on the near side of the intersection or, if there is no crosswalk, then as near as practical to the nearest line of the intersecting street or roadway.

(M) One-way streets, roads and alleys. Whenever ~~the division of traffic transportation~~ transportation and parking services designates a street, roadway or alley as a one-way ~~street, roadway or alley~~, signs giving notice thereof shall be placed and maintained. No such rule shall be effective unless such signs are in place. Signs indicating the direction of lawful traffic movement shall be placed at every intersection where movement of traffic in the opposite direction is prohibited.

(N) Restriction on direction during certain periods. ~~The division of traffic Transportation~~ Transportation and parking services is hereby authorized to determine and designate streets and roadways, parts of streets and roadways or specific lanes thereon upon which vehicular traffic shall proceed in one direction during one period and the opposite direction during another period of the day, and shall either position law enforcement officers, hospital and campus security officers, or traffic control officers, or place and maintain appropriate markings, signs, barriers or other devices to give notice thereof. The ~~division~~ department may erect signs temporarily designating lanes to be used by traffic moving in a particular direction, regardless of the centerline of the street and roadway.

(O) Markers, buttons and signs regulating turns. ~~The division of traffic Transportation~~ Transportation and parking services is hereby authorized to place markers, buttons or signs within or adjacent to

intersections indicating the course to be traveled by vehicles turning at such intersections. Such course to be traveled as so indicated may conform to or be other than as prescribed by state statute or these rules.

- (P) Additional turning restrictions. ~~The division of traffic~~ Transportation and parking services is hereby authorized to determine those intersections at which drivers of vehicles shall not make a right, left or "U" turn, and shall place proper signs at such intersections. The making of such turns may be prohibited between certain hours of any day and permitted at other hours, in which event the same shall be plainly indicated on the signs or they may be removed when such turns are permitted.
- (Q) Regulation of speed. ~~The division of traffic~~ Transportation and parking services is hereby authorized to regulate the timing of traffic in an orderly and safe manner at speeds slightly at variance from the speeds otherwise applicable within the vicinity or at intersections and shall erect appropriate signs giving notice thereof.
- (R) Signs or markings indicating angle or parallel parking.
 - (1) ~~The division of traffic~~ Transportation and parking services shall determine upon what streets and roadways and parking areas angle or parallel parking shall be permitted and shall mark or sign such streets and roadways and parking areas.
 - (2) Unchanged.
- (S) Bus stops and taxicab stands. ~~The division of traffic~~ Transportation and parking services shall establish bus stops, bus stands, taxicab stands and stands for other passenger common-carrier motor vehicles on streets and roadways in such places ~~and in such number as is of the greatest benefit and convenience~~ that provide adequate accessibility and safety to the public. Every such bus stop, bus stand, taxicab stand or other stand shall be designated by appropriate signs.
- (T) Loading zones. ~~The division of traffic~~ Transportation and parking services is hereby authorized to determine the location of passenger and freight curb loading zones and shall place and maintain appropriate signs indicating the same and stating the hours during which they may be lawfully used.

3335-21-12 Pedestrians.

- (A) Unchanged.
- (B) Right of way in crosswalks; overtaking stopped vehicles.
 - (1) and (2) unchanged.
 - (3) Whenever a vehicle is stopped at a marked crosswalk or at an unmarked crosswalk at an intersection to permit a pedestrian to cross the street or roadway, the driver of any other vehicle approaching from the rear shall not overtake and pass such stopped vehicle as set forth in section 4511.46 of the Revised Code.
- (C) Movement in crosswalks. Pedestrians shall move, wherever practical, upon the right half of crosswalks as set forth in section 4511.49 of the Revised Code.
- (D) Unchanged.
- (E) Right of way of motorists.
 - (1) Unchanged.

- (2) Any pedestrian crossing a street or roadway at a point where a pedestrian tunnel or overhead pedestrian crossing has been provided shall yield the right of way to all traffic upon the street or roadway as set forth in section 4511.48 of the Revised Code.
- (F) Prohibited crossings. Between adjacent intersections at which traffic control signals are in operation, pedestrians shall not cross at any place except in a marked crosswalk as set forth in section 4511.48 of the Revised Code.
- (G) Walking on streets and roadways.
 - (1) Unchanged.
 - (2) Where sidewalks are not available, any pedestrian walking along and upon a street or roadway shall walk only on a shoulder, or if no shoulder is available, shall walk as far as practical from the edge of the street or roadway as set forth in section 4511.50 of the Revised Code.
- (H) and (I) unchanged.
- (J) Right of way of blind ~~person~~ persons.
 - (1) Unchanged.
 - (2) No person, other than a blind person, while on any public highway, street, alley or other public thoroughfare, shall carry a white or metallic cane, with or without a red tip as set forth in section 4511.47 of the Revised Code.
- (K) Unchanged.
- (L) Hanging onto or riding on outside of vehicles. No person shall hang onto, or ride on the outside of, a motor vehicle while it is moving upon a street or roadway, except mechanics or test engineers making repairs or adjustments. No operator shall knowingly permit a person to hang onto, or ride on the outside of, a motor vehicle while it is moving upon a street or roadway, except mechanics or test engineers making repairs or adjustments as set forth in section 4511.51 of the Revised Code.

3335-21-13 ~~Vehicles and operation~~ Operations generally.

- (A) Driving upon right side of street or roadway; exceptions. Upon all streets and roadways of sufficient width, a vehicle shall be driven upon the right half of the street or roadway, except as follows:
 - (1) through (4) unchanged.
 - (5) When otherwise directed by a law enforcement officer, traffic control device, hospital safety and campus security officer, traffic and ~~parking control~~ control officer, public safety or transportation and parking personnel or student traffic ~~controller~~ officer as set forth in section 4511.25 of the Revised Code.
- (B) Vehicles traveling in opposite directions. Operators of vehicles proceeding in opposite directions shall pass each other to the right, and upon streets and roadways having width for not more than one line of traffic in each direction, each operator shall give to the other one-half of the main traveled portion of the street or roadway or as nearly one-half as is reasonably possible as set forth in section 4511.26 of the Revised Code.
- (C) Overtaking and passing a vehicle. The following rules govern the overtaking and passing of vehicles proceeding in the same direction:

- (1) Unchanged.
 - (2) Except when overtaking and passing on the right is permitted, the operator of an overtaken vehicle shall give way to the right in favor of the overtaking vehicle at the latter's audible signal, and such operator shall not increase the speed of the vehicle until completely passed by the overtaking vehicle as set forth in section 4511.27 of the Revised Code.
- (D) and (E) unchanged.
- (F) Driving through safety zones. No vehicle shall at any time be driven through or within a safety zone as set forth in section 4511.60 of the Revised Code.
 - (G) Overtaking, passing to left of centerline. No vehicle shall be driven to the left of the center of the roadway in overtaking and passing traffic proceeding in the same direction, unless such left side is clearly visible and is free of oncoming traffic for a sufficient distance ahead to permit such overtaking and passing to be completely made, without interfering with the safe operation of any traffic approaching from the opposite direction or any traffic overtaken. In every event the overtaking vehicle must return to an authorized lane of travel as soon as practicable and in the event the passing movement involves the use of a lane authorized for traffic approaching from the opposite direction, before coming within two hundred feet of any approaching vehicle as set forth in section 4511.29 of the Revised Code.
 - (H) Driving upon left side of street or roadway. No vehicle shall be driven upon the left side of the roadway under the following conditions:
 - (1) and (2) unchanged.
 - (3) When approaching within one hundred feet of or traversing any intersection or railroad grade crossing.

This paragraph does not apply to vehicles upon a one-way roadway, upon a roadway where traffic is lawfully directed to be driven to the left side or under the conditions described in paragraph (A) of this rule as set forth in section 4511.30 of the Revised Code.
 - (I) Driving within traffic lanes. When traffic lanes are marked upon a street or roadway, ~~no all operator operators~~ of a vehicle shall ~~fail or refuse to keep such vehicle remain~~ within the boundaries of any such lane ~~except when lawfully passing another vehicle or preparatory to making a lawful turning movement~~ marked lanes.
 - (J) Turning at intersections. The driver of a vehicle intending to turn at an intersection shall be governed by the following rules:
 - (1) and (2) unchanged.
 - (3) At any intersection where traffic is restricted to one direction on one or more of the roadways, the driver of a vehicle intending to turn left at any such intersection shall approach the intersection in the extreme left-hand lane lawfully available to traffic moving in the direction of travel of such vehicle, and after entering the intersection the left turn shall be made so as to leave the intersection, as nearly as practicable, in the left-hand lane of the roadway being entered lawfully available to the traffic moving in that lane as set forth in section 4511.36 of the Revised Code.
 - (K) Unchanged.

- (L) "U" turns.
- (1) No vehicle shall be turned so as to proceed in the opposite direction upon a curve, or upon the approach to or near the crest of a grade, if such vehicle cannot be seen within five hundred feet by the driver of a vehicle approaching from either direction as set forth in section 4511.37 of the Revised Code.
 - (2) Unchanged.
- (M) Signals before changing course, turning or stopping.
- (1) through (4) unchanged.
- (5) The signal lights required by this rule shall not be flashed ~~on one side only on a disabled vehicle,~~ flashed as a courtesy or "do pass" signal to operators of other vehicles approaching from the rear, nor be flashed on one side only of a parked vehicle except as may be necessary for compliance with this rule as set forth in section 4511.39 of the Revised Code.
- (N) Hand and arm signals. All signals ~~required by these rules,~~ when given by hand and arm, shall be given from the left side of the vehicle in the following manner, and such signals shall indicate as follows:
- (1) and (2) unchanged.
- (3) Stop or decrease speed, hand and arm extended downward as set forth in section 4511.40 of the Revised Code.
- (O) Unchanged.
- (P) Right of way when turning left. The operator of a vehicle intending to turn to the left within an intersection or into an alley, private road or driveway shall yield the right of way to any vehicle approaching from the opposite direction whenever the approaching vehicle is within the intersection or so close to the intersection, alley, private road or driveway as to constitute an immediate hazard as set forth in section 4511.42 of the Revised Code.
- (Q) Obedience to stop signs.
- (1) Except when directed to proceed by a law enforcement officer, a traffic ~~and parking control~~ officer, a hospital ~~safety and campus~~ security officer or a student traffic ~~controller officer~~, every driver of a vehicle approaching a stop sign shall stop at a clearly marked stop line, or if none, before entering the crosswalk on the near side of the intersection, or if none, then at the point nearest the intersecting street or roadway where the driver has a view of approaching traffic on the intersecting street or roadway before entering it.
 - (2) After having stopped, the driver shall yield the right of way to any vehicle in the intersection or approaching on another street or roadway so closely as to constitute an immediate hazard during the time the driver is moving across or within the intersection or junction of streets or roadways as set forth in section 4511.43 of the Revised Code.
- (R) Obedience to yield signs.
- (1) Unchanged.
 - (2) After slowing or stopping, the driver shall yield the right of way to any vehicle in the intersection or approaching on another street or roadway so closely as to constitute an immediate hazard during the time the driver is moving across or within the intersection or junction of streets or roadways. Whenever a driver is involved in a collision with a vehicle

in the intersection or junction of streets or roadways, after driving past a yield sign without stopping, the collision shall be prima-facie evidence of the driver's failure to yield the right of way as set forth in section 4511.43 of the Revised Code.

- (S) Emerging from alley, driveway or building. The driver of a vehicle emerging from an alley, building, private road or driveway shall stop the vehicle immediately prior to driving onto a sidewalk or onto the sidewalk area extending across the alley, building entrance, road or driveway, or in the event there is no sidewalk area, shall stop at the point nearest the street to be entered where the driver has a view of approaching traffic thereon as set forth in section 4511.43.1 of the Revised Code.
- (T) Blocking intersections. No driver shall enter an intersection or a marked crosswalk unless there is sufficient space on the other side of the intersection or crosswalk to accommodate the vehicle he or she is operating without obstructing the passage of other vehicles or pedestrians, notwithstanding any traffic control signal indication to proceed as set forth in section 4511.71.2 of the Revised Code.
- (U) Crossing fire hose. No vehicle shall, without the consent of the fire department official in command, be driven over any unprotected hose of a fire department, when such hose is laid down on any street or private driveway to be used at any fire or alarm of fire as set forth in section 4511.73 of the Revised Code.
- (V) Driving upon sidewalks. No person shall drive any vehicle upon a sidewalk or sidewalk area except upon a permanent or duly authorized temporary driveway as set forth in section 4511.71.1 of the Revised Code.
- (W) Limitations on backing. Before backing, operators of vehicles shall give ample warning, and while backing they shall exercise vigilance not to injure person or property on the street or roadway as set forth in section 4511.38 of the Revised Code.
- (X) Starting without safety. No person shall start a vehicle which is stopped, standing or parked until such movement can be made with reasonable safety as set forth in section 4511.38 of the Revised Code.
- (Y) and (Z) unchanged.
- (AA) Driving onto or from controlled-access streets or roadways. No person shall drive a vehicle onto or from a controlled-access street or roadway except at established entrances and excesses exits.
- (BB) Unchanged.
- (CC) Speed; assured clear distance.
 - (1) Speed limits. The speed limit on university streets or roadways shall be twenty-five miles per hour or as posted by official traffic control devices placed by ~~the division of traffic transportation~~ and parking services upon the basis of engineering and traffic investigations.
 - (2) and (3) unchanged.
- (DD) and (EE) unchanged.

3335-21-14 Equipment.

- (A) Unsafe vehicles. No person shall drive or move, or cause or knowingly permit to be driven or moved, on any street or roadway, a vehicle or combination of vehicles which is in such an unsafe condition as to endanger any person or property as set forth in section 4513.02 of the Revised Code.
- (B) Bumpers. No person shall operate upon a street or roadway ~~any a~~ motor vehicle that:
 - (1) Unchanged.
 - (2) Has a suspension system or body so modified that the height of any bumper on the vehicle varies more than three inches from the original manufactured bumper height for the vehicle as set forth in section 4513.02.1 of the Revised Code.
- (C) Bumper specifications. ~~The division of traffic~~ Transportation and parking services shall furnish each facilitate, ~~when asked by law enforcement-officer officers, traffic and parking-officer control officers and hospital-safety and campus security-officer officers~~ with the current manufacturer's bumper specifications.
- (D) Lighted lights required. Every vehicle upon a street or highway during the time from one-half hour after sunset to one-half hour before sunrise, and at any other time when there are unfavorable atmospheric conditions or when there is not sufficient natural light to render discernible persons, vehicles and substantial objects on the street at a distance of one thousand feet ahead, shall display lighted lights and illuminating devices as required by this rule for different classes of vehicles, except that every motorized bicycle shall display at such times lighted lights meeting the rules adopted by the Ohio director of highway public safety under section 4511.521 of the Revised Code. No motor vehicle, during such times, shall be operated upon a street or highway using only parking lights as illumination as set forth in section 4513.03 of the Revised Code.
- (E) Headlights. Every motor vehicle, other than a motorcycle, shall be equipped with at least two headlights with at least one near each side of the front of the motor vehicle as set forth in section 4513.04 of the Revised Code.
- (F) Tail light; illumination of rear license plate.
 - (1) Unchanged.
 - (2) Either a tail light or a separate light shall be so constructed and placed as to illuminate with a white light the rear registration plate, when such registration plate is required, and render it legible from a distance of fifty feet to the rear. Any tail light, together with any separate light for illuminating the rear registration plate, shall be so wired as to be lighted whenever the headlights of auxiliary driving lights are lighted, except where separate lighting systems are provided for trailers for the purpose of illuminating such registration plate as set forth in section 4513.05 of the Revised Code.
- (G) Rear red reflectors. Every new motor vehicle sold after September 6, 1941, and operated on a street, other than vehicles of the type mentioned in section 4513.07 of the Revised Code or a commercial tractor to which a trailer or semitrailer is attached, shall carry at the rear, either as a part of the tail lights or separately, two red reflectors of such size and characteristics and so maintained so to be visible at night from all distances within three hundred feet to fifty feet from such vehicle as set forth in section 4513.06 of the Revised Code.
- (H) Red light or red flag on extended loads. Whenever the load upon any vehicle extends to the rear four feet or more beyond the bed or body of such vehicle, there shall be displayed at the extreme rear end of the load, at the times specified in paragraph (D) of this rule, a red light or

lantern plainly visible from a distance of at least five hundred feet to the side and rear. The red light or lantern required by this section is in addition to the red rear light required upon every vehicle. At any other time there shall be displayed at the extreme rear end of such load a red flag, or cloth not less than sixteen inches square as set forth in section 4513.09 of the Revised Code.

(I) Number of lights permitted, red and flashing lights.

(1) through (3) unchanged.

(4) Except a person operating a public safety vehicle or a school bus, no person shall operate, move or park upon, or permit to stand within the right of way of any public street or highway any vehicle or equipment which is equipped with and displaying a flashing red or a flashing combination red and white light, or an oscillating or rotating red light, or a combination red and white oscillating or rotating light; and except a law enforcement officer, or other person sworn to enforce the traffic laws of the state or the university, operating a public safety vehicle when on duty, no person shall operate, move or park upon, or permit to stand within the right of way of any street or roadway any vehicle or equipment which is equipped with, or upon which is mounted, and displaying a flashing blue or a flashing combination blue and white light, or an oscillating or rotating blue light, or a combination blue and white oscillating or rotating light. This paragraph shall not prohibit the use of warning lights required by law or the simultaneous flashing of turn signals on disabled vehicles as set forth in section 4513.17 of the Revised Code.

(J) Horn, siren and theft alarm signal.

(1) Unchanged.

(2) No motor vehicle shall be equipped with, nor shall any person use upon a vehicle, any siren, whistle or bell. Any vehicle may be equipped with a theft alarm signal device which shall be so arranged that it cannot be used as an ordinary warning signal. Every emergency or public safety vehicle shall be equipped with a state approved siren, whistle or bell capable of emitting sound audible under normal conditions from a distance of not less than five hundred feet. Such equipment shall not be used except when such vehicle is operated in response to an emergency call or is in the immediate pursuit of an actual or suspected violator of the law, in which case the driver of the emergency or public safety vehicle shall sound such equipment when it is necessary to warn pedestrians and other drivers of the approach thereof as set forth in section 4513.21 of the Revised Code.

(K) Rear-view mirror; clear view to front, both sides and rear. Every motor vehicle and motorcycle shall be equipped with a mirror so located as to reflect to the operator a view of the street to the rear of such vehicle or motorcycle. Operators of vehicles and motorcycles shall have a clear and unobstructed view to the front and to both sides of their vehicles or motorcycles and shall have a clear view to the rear of their vehicles or motorcycles by mirror as set forth in section 4513.23 of the Revised Code.

(L) Sign or poster upon windshield; windshield wiper.

(1) Unchanged.

(2) The windshield on every motor vehicle shall be equipped with a device for cleaning rain, snow or other moisture from the windshield, which device shall be maintained in good working order and so constructed as to be controlled or operated by the operator of the vehicle as set forth in section 4513.24 of the Revised Code.

- (M) Muffler; muffler cutout; excessive smoke, gas or noise.
 - (1) Unchanged.
 - (2) No person shall own, operate or have in his possession any motor vehicle or motorcycle equipped with a device for producing excessive smoke or gas, or so equipped as to permit oil or any other chemical to flow into or upon the exhaust pipe or muffler of such vehicle, or equipped in any other way to produce or emit smoke or dangerous or annoying gases from any portion of such vehicle, other than the ordinary gases emitted by the exhaust of an internal combustion engine under normal operation as set forth in section 4513.22 of the Revised Code.

3335-21-15 Motor vehicle and motorcycle brakes.

The following requirements govern as to brake equipment on vehicles:

- (A) Motor vehicle and motorcycle brakes. Every motor vehicle, other than a motorcycle, when operated upon a street or highway, shall be equipped with brakes adequate to control the movement of and to stop and hold such motor vehicle, including two separate means of applying the brakes, each of which means shall be effective to apply the brakes to at least two wheels. If these two separate means of applying the brakes are connected in any way, then on such motor vehicles manufactured or assembled after January 1, 1942, they shall be so constructed that failure of any one part of the operating mechanism shall not leave the motor vehicle without brakes on at least two wheels.
- (B) Adequate brakes. Every motorcycle, when operated upon a street or highway, shall be equipped with at least one adequate brake, which may be operated by hand or by foot.
- (C) Equipped with brakes. Every motorized bicycle shall be equipped with brakes meeting the rules adopted by the Ohio director of highway public safety.
- (D) Sustained rate. Every motor vehicle or combination of motor-drawn vehicles shall be capable at all times and under all conditions of loading of being stopped on a dry, smooth, level road free from loose material, upon application of the service or foot brake, within the following specified distances, or shall be capable of being decelerated at a sustained rate corresponding to these distances:

	From a speed of twenty miles per hour	
	Stopping distance in feet	Deceleration in feet per second
Brakes on all wheels	thirty	fourteen
Brakes not on all four wheels	forty	ten seven

- (E) Good working order. All brakes shall be maintained in good working order and shall be so adjusted as to operate as equally as practicable with respect to the wheels on opposite sides of the vehicle as set forth in section 4513.20 of the Revised Code.
- (F) Snow removal equipment. No person shall operate snow removal equipment on a street or roadway unless the lights thereon comply with and are lighted when and as required by the standards and specifications adopted by the Ohio director of transportation as set forth in section 4513.18 of the Revised Code.
- (G) Unchanged.

3335-21-16 Emergency and public safety vehicles.

- (A) Privileges of drivers. The driver of an authorized emergency vehicle or public safety vehicle, when responding to an emergency call, or when in the pursuit of an actual or suspected violator of the law, or when responding to but not upon returning from a fire or other emergency alarm, may exercise the privileges set forth in this rule, but subject to the conditions herein stated. The driver of an authorized emergency vehicle or public safety vehicle may:
- (1) through (3) unchanged.
- (4) ~~Disregard regulations~~ rules governing direction of movement or turning in specified directions.
- (B) Operation of vehicles on approach of authorized emergency or public safety vehicles. The exemptions herein granted to an authorized emergency vehicle or public safety vehicle shall apply only when the driver of any such vehicle, while in motion, sounds an audible signal by bell, siren or exhaust whistle, as may be reasonably necessary, and when the vehicle is equipped with at least one lighted lamp displaying authorized emergency light visible under normal atmospheric conditions from a distance of five hundred feet to the front of such vehicle, except that an authorized emergency vehicle or public safety vehicle operated as a police vehicle need not be equipped with or display an authorized emergency light visible from in front of the vehicle.
- (C) Driver's responsibility. The foregoing provisions shall not relieve the driver of an authorized emergency vehicle or public safety vehicle from the duty to drive with due regard for the safety of all persons using a street or roadway, nor shall such provisions protect the driver from the consequences of his or her reckless disregard for the safety of others.
- (D) ~~Operation of vehicles on approach of authorized~~ Vehicles approaching emergency vehicles or public safety vehicles.
- (1) Upon the immediate approach of an authorized emergency vehicle or public safety vehicle making use of audible and visual signals meeting the requirements of these rules and/or state law, the driver of every other vehicle shall yield the right of way and shall immediately drive to a position parallel to, and as close as possible to, the right edge or curb of the street or roadway, clear of any intersection, and shall stop and remain in such position until the authorized emergency vehicle has passed, except when otherwise directed by a law enforcement officer, hospital ~~safety~~ and campus security officer or ~~traffic transportation~~ and parking officer.
- (2) Paragraph (D)(1) of this rule shall not operate to relieve the driver of an authorized emergency vehicle or public safety vehicle from the duty to drive with due regard for the safety of all persons using the street or roadway.
- (E) Following emergency or public safety vehicles. The driver of a vehicle, other than an emergency vehicle or a public safety vehicle on official business, shall not follow an emergency vehicle or a public safety vehicle, traveling in response to a fire alarm, closer than five hundred feet, or drive into or park such vehicle within the block where the fire apparatus has stopped in answer to a fire alarm, unless directed to do so by a law enforcement officer, traffic and parking control officer, hospital ~~safety~~ and campus security officer or fireman firefighter as set forth in section 4511.72 of the Revised Code.

3335-21-17 Motorcycles.

Riding of motorcycles. A person operating a motorcycle shall not ride other than upon the permanent and regular seat attached thereto or carry any other person upon such motorcycle other than on a firmly attached and regular seat thereon, nor shall any person ride upon a motorcycle other than upon such a firmly attached and regular seat as set forth in section 4511.53 of the Revised Code.

3335-21-18 Bicycles, motorized bicycles and toy vehicles.

- (A) Application of rules to bicycles. The provisions of these rules that are applicable to bicycles shall apply whenever a bicycle is operated upon a street or roadway or upon a path set aside for the exclusive use of bicycles, subject to the exceptions stated in this rule.
- (1) Unchanged.
 - (2) Any person operating a bicycle shall obey the instructions of official traffic control signals, signs and other control devices applicable to vehicles or pedestrians, unless otherwise directed by a law enforcement officer, traffic and ~~parking control~~ control officer, hospital safety and campus security officer, public safety or transportation and parking personnel or student traffic ~~controller~~ officer.
 - (3) Unchanged.
- (B) Registration; application form.
- (1) A person riding or propelling a bicycle upon university property, grounds, streets or roadways, or parking such bicycle upon university property, ~~may~~ should register such bicycle with ~~the division of transportation~~ and parking services upon application for registration as provided in this rule.
 - (2) Application of bicycle registration and a decal or sticker shall be made upon a form provided by the ~~division~~ department and shall be made to its ~~manager~~ director or his or her designee.
- (C) Issuance of registration.
- (1) ~~The division of transportation~~ Transportation and parking services, upon receiving a proper application therefor, is hereby authorized to issue a bicycle registration decal or sticker.
 - (2) The ~~division~~ department shall not issue a registration decal or sticker for any bicycle when there are reasonable grounds to believe that the applicant is not the owner of or entitled to the possession of such bicycle.
 - (3) The ~~division~~ department shall keep a record of the number of each registration decal or sticker, the date it is issued, the name and address of the person to whom it is issued, and the number of the frame of the bicycle for which it is issued.
- (D) Attachment and removal of decals or stickers.
- (1) ~~The division of transportation~~ Transportation and parking services, upon ~~issuing~~ receiving a bicycle registration, shall issue a registration decal or sticker bearing the registration number assigned to the bicycle and the name of the university.

- (2) The registrant shall cause such registration decal or sticker from a bicycle ~~except upon transfer of ownership or if the bicycle is dismantled and no longer operated upon a university street or roadway~~ to be firmly attached to the frame of the bicycle for which it is issued, per instructions printed on the back of the decal or sticker, in such position as to be plainly visible.
- (3) No person shall remove a registration decal or sticker from a bicycle ~~except if the decal or sticker expires,~~ upon transfer of ownership or if the bicycle is dismantled and no longer operated upon a university street or roadway.
- (E) Sale or transfer of registered bicycles. Upon the sale or other transfer of a registered bicycle, the registration ~~registrant shall remove the~~ decal or sticker ~~and shall be surrendered~~ surrender the same to the ~~division of transportation and parking services.~~
- (F) Records of bicycle registration. ~~The division of transportation~~ Transportation and parking services shall maintain bicycle registration records for a period of five years.
- (G) through (I) unchanged.
- (J) Emerging from alley or driveway. The operator of a bicycle emerging from an alley or driveway shall, upon approaching a sidewalk or a sidewalk area extending across such alley or driveway, yield the right of way to all pedestrians approaching on such sidewalk or sidewalk area, and upon entering the street or roadway shall yield the right of way to all vehicles approaching on such street or roadway.
- (K) Carrying articles. No person operating a bicycle shall carry any package, bundle or article which prevents the operator from keeping at least one hand upon the handlebars as set forth in section 4511.53 of the Revised Code.
- (L) Unchanged.
- (M) Riding on sidewalks.
- (1) Unchanged.
- (2) ~~The division of transportation~~ Transportation and parking services is hereby authorized to erect signs on any sidewalk, street or roadway prohibiting the riding of bicycles thereon by any person and when such signs are in place no person shall disobey the same.
- (N) Lights, signal devices, brakes on bicycles.
- (1) Every bicycle when in use shall ~~be equipped with a lamp on the front that~~ at nighttime shall emit a white light visible from a distance of at least five hundred feet to the front and with a red reflector on the rear of a type approved by the Ohio director of public safety that shall be visible from all distances from one hundred feet to six hundred feet to the rear when directly in front of lawful lower beams of headlamps on a motor vehicle and a lamp emitting a red light visible from a distance of five hundred feet to the rear shall be used in addition to the red reflector.
- (2) Unchanged.
- (3) Every bicycle shall be equipped with an adequate brake when used on a street or highway as set forth in section 4511.56 of the Revised Code.
- (O) Unchanged.

- (P) Attaching bicycles, motorcycles to other vehicles. No person riding upon any motorcycle, bicycle, coaster, roller skates, roller blades, skateboards, sled, or toy vehicle shall attach the same or himself or herself to any vehicle upon a roadway.

No operator shall knowingly permit any person riding upon any motorcycle, bicycle, coaster, roller skates, roller blades, skateboards, sled or toy vehicle to attach the same or himself or herself to any vehicle while it is moving upon a roadway. This paragraph does not apply to the towing of a disabled vehicle as set forth in section 4511.54 of the Revised Code.

- (Q) Notices of violation. The operator of a bicycle in violation of any of the provisions of these rules may be issued a notice of violation by ~~the division of~~ transportation and parking services or a law enforcement officer or a hospital safety and campus security officer of the university.

- (R) Impounding of bicycles, skateboards, roller skates, roller blades, coasters or similar devices. Any bicycle, skateboard, roller skate, roller blade, coaster, or similar device used in violation of any of the provisions of these rules may be impounded by and held in the custody of ~~the division of~~ transportation and parking services until there is final disposition of all issued notices of violation. Any impounded bicycle, skateboard, roller skate, roller blade, coaster, or similar device held in custody by the ~~division~~ department for longer than ninety consecutive days may be disposed of through ~~the university surplus property department~~ an approved university process.

- (S) Unchanged. (B/T 12/4/98)

3335-21-19 Parking generally.

- (A) General prohibition. No person shall stop, stand or park a vehicle on the streets, roadways, land or property of the university except in areas and at the times and under the conditions specified by these rules or by signs posted by order of ~~the division of traffic~~ transportation and parking services.

- (B) Unchanged.

- (C) Angle and parallel parking.

(1) On those streets, roadways or parking areas which have been signed or marked by ~~the division of traffic-transportation~~ and parking services for angle or parallel parking, no person shall park or stand a vehicle other than at the angle or position indicated by such signs or markings.

(2) and (3) unchanged.

- (D) Lights on parked or stopped vehicles. Except in cases of an emergency, whenever a vehicle is parked or stopped upon a roadway open to traffic or shoulder adjacent thereto, whether attended or unattended during the times mentioned in paragraph (D) of rule 3335-21-14 of the Administrative Code, such vehicle shall be equipped with one or more lights which shall exhibit a white or amber light on the roadway side visible from a distance of five hundred feet to the front of such vehicle, and a red light visible from a distance of five hundred feet to the rear. No lights need be displayed upon any such vehicle when it is stopped or parked where there is sufficient light to reveal any person or substantial object within a distance of five hundred feet upon such street. Any lighted headlights upon a parked vehicle shall be depressed or dimmed as set forth in section 4513.10 of the Revised Code.

- (E) Stopping, standing or parking prohibited in specified places. No person shall stop, stand or park a vehicle, except when necessary to avoid conflict with other traffic or in compliance with state statute or these rules or the directions of a law enforcement officer, traffic control device or employee of ~~the division of traffic-transportation~~ and parking services, in any of the following places:

(1) through (7) unchanged.

(8) ~~Between a safety zone and the adjacent curb or within thirty feet of points on the curb immediately opposite the ends of a safety zone, unless the division indicates a different length by signs or markings~~ entrance to any fire station, within seventy-five feet of the entrance when it is properly posted with signs;

(9) through (15) unchanged.

(16) In any area, zone or parking space to which access, or in which parking, is prohibited by the placement of barricades authorized by the ~~division~~ department; or

(17) Unchanged.

(F) and (I) unchanged.

(J) Parking on narrow streets or roadways.

(1) ~~The division of traffic~~ Transportation and parking services is hereby authorized to erect signs prohibiting parking upon a street or roadway when the width of the street or roadway does not exceed twenty feet, or upon one side of a street or roadway, as indicated by such signs, when the width of the street or roadway does not exceed thirty feet.

(2) Unchanged.

(K) Standing or parking on one-way streets or roadways.

(1) ~~The division of traffic~~ Transportation and parking services is hereby authorized to erect signs upon the left-hand side of a one-way street or roadway to prohibit the standing or parking of vehicles. When such signs are in place, no person shall stand or park a vehicle upon such left-hand side in violation of any such sign.

(2) If a ~~highway~~ roadway includes two or more separate streets ~~or roadways~~ and traffic is restricted to one direction upon any such street ~~or roadway~~, no person shall stand or park a vehicle upon the left-hand side of such one-way street ~~or roadway~~ unless signs are erected to permit such standing or parking. The ~~division~~ department is hereby authorized to determine when standing or parking may be permitted upon the left-hand side of any such one-way street ~~or roadway~~ and to erect signs giving notice thereof.

(L) Stopping, standing or parking in hazardous congested places.

(1) ~~The division of traffic~~ Transportation and parking services is hereby authorized to determine and designate by proper signs places not exceeding one hundred feet in length in which the stopping, standing or parking of vehicles would create an especially hazardous condition or would cause unusual delay to traffic.

(2) Unchanged.

(M) Unchanged.

(N) Loading zones.

(1) Passenger curb loading zones. No person shall stop, stand or park a vehicle for any purpose or period of time, other than for the expeditious loading or unloading of passengers, in any place marked as a passenger curb loading zone during hours when the rules applicable to such zone are in effect, and then only for a period not to exceed three minutes unless otherwise marked.

- (2) Freight Loading Zones. No person shall stop, stand or park a vehicle for any purpose or length of time, other than for the expeditious unloading and delivery or pickup and loading of materials, in any place marked as a freight loading zone during hours when the regulations rules applicable to such zone are in effect, and then only for a period not to exceed thirty minutes the posted time limit.
- (O) Unchanged.
- (P) Delivery permits.
- (1) Unchanged.
- (2) All applications for departmental delivery permits must be approved by the appropriate dean or department head before being reviewed by the ~~manager of the division of traffic~~ director of transportation and parking, or designee, and are only valid when displayed along with a valid university parking permit.
- (3) Delivery permit users shall comply with ~~division~~ department rules. The delivery permit does not relieve the operator from responsibility for violations of these rules.
- (4) ~~The delivery A permit is not valid within~~ for one-time access to the traffic controlled zone. ~~To obtain access to this area, the user must enter at the information booth at the corner of Seventeenth avenue and Millikin road~~ only can be obtained at the information booths located at control zone entrances.
- (5) Unchanged.
- (Q) Moving of vehicle. No person shall move a vehicle not lawfully under his or her control into any such prohibited area or away from a curb such distance as is prohibited by these rules.
- 3335-21-20 Stopping, standing or parking permitted, restricted or prohibited on certain streets, roadways and parking areas.
- (A) Application of rule. The provisions of this rule prohibiting the standing or parking of vehicles shall apply at all times or at those times herein specified or as indicated on official signs, except when it is necessary to stop a vehicle to avoid conflict with other traffic or in compliance with the directions of a traffic ~~and parking control~~ control officer, a law enforcement officer or an official traffic control device placed by the ~~division of traffic transportation and parking services~~.
- (B) Unchanged.
- (C) Parking prohibited. Parking is prohibited at all times on certain streets and roadways. When signs are erected by the ~~division~~ department giving notice thereof, no person shall park a vehicle at any time upon any street or roadway that is signposted .
- (D) Parking limited time. Parking time may be limited on certain streets and roadways. The ~~division~~ department is hereby authorized to establish limited time parking on certain streets and roadways by posting signs giving notice thereof. ~~No person shall park a vehicle between the hours of eight a.m. and four p.m. of any day, except Sundays and legal holidays when classes are not in session, when signs are erected in each block giving notice thereof.~~
- (E) Parking permitted. Parking of vehicles may be permitted by the ~~division~~ department in and on the following areas of the streets, roadways, land and property of the university, as designated by erected signs:

- (1) Parking lots. Parking may be permitted on lands and property assigned to the division department and designated by erected signs.
 - (2) Parking zones categories. The division department may divide allocate the available parking area on the land and property of the university into zones and permit parking by persons therein categories restricting or specifying permit designations as follows:
 - (a) ~~Zone "A".~~ Zone "A" or "WA" parking areas may consist of marked areas along streets and roadways, garages and of certain parking lots and shall be reserved for faculty members, certain staff members and employees and certain students available to individuals displaying a current "A" or "WA" parking permit. ~~Certain zone "A" areas may also be available for visitor use.~~
 - (b) ~~Zone "B".~~ Zone "B" or "WB" parking areas may consist of marked spaces along streets and roadways, garages and of certain parking lots and shall be reserved for faculty members and staff members and certain students available to individuals displaying a current "B" or "WB" parking permit.
 - (c) ~~Zone "C".~~ Zone "C" or "WC" areas shall be parking areas reserved for students and used at times by faculty and staff may consist of marked spaces along streets and roadways, garages and certain parking lots and shall be available to individuals displaying a current "C" or "WC" parking permit.
 - (d) "R" parking areas may consist of marked spaces along streets and roadways, garages and certain parking lots and shall be available based upon restrictions designated on the sign.
 - (3) Pay-parking facilities. Certain parking areas may be designated as pay-parking facilities, and a schedule of fees for such parking shall be established by the division department. Parking in such areas may be open to all persons or limited by rule of the division department. No person parking in a pay facility shall refuse to pay the prescribed fee.
 - (4) Public event parking. Public parking of motor vehicles while drivers or operators thereof attend public events on the land and property of the university, other than that usually used for parking, may be permitted under such regulations rules and controls and for such fees as designated by the division department.
 - (5) Signs. Whenever the division department provides by rule that any area shall be limited to certain parking, such rule shall be effective when proper signs, giving notice that parking is limited to certain persons or times, have been erected in the area or when law enforcement officers or parking personnel are present and are directing parking and traffic thereto and therefrom.
- (F) Regulated parking times time. Parking shall be permitted in areas designated herein only at the following times and under the following conditions, whether or not university classes are in session:
- (1) From the hours of ~~seven~~ five a.m. to four p.m., Monday through Friday, parking shall be limited to designated permit zones. From four p.m. to two a.m., Monday through Friday, and from four p.m. Friday to two a.m. Monday, "B" or "C" and "WA", "WB" and "WC" permit holders may park in "A" or "B" zones, except that certain areas or zones may be designated as restricted, limited or reserved and signs shall be posted in accordance with paragraph (E)(5) of this rule.

- (2) ~~There shall be~~ Certain areas may be designated as no parking or restricted parking on the streets, roadways, land and property of the university between two a.m. and five a.m. at any time except with a disability permit.
- (3) ~~Students with current decals may~~ be eligible to purchase a "P" proximity permit or "R" remote permit, allowing overnight parking in certain designated parts of zone "C" or "WC" areas. Application and approval shall be made in accordance with rules established by the division department.
- (G) Parking meter zones.
- (1) ~~The division of traffic~~ Transportation and parking services is hereby authorized to ~~establish~~ install parking meter zones meters to regulate short-term parking within parking areas or upon those streets and roadways or parts of streets and roadways ~~that are regulated by~~ where it is determined that the installation of parking meters is necessary to aid in the regulation and control of parking vehicles.
- (2) ~~The division may establish parking meter zones at other locations within parking areas or upon those streets and roadways or parts of streets and roadways where it is determined, upon the basis of an engineering and traffic investigation that the installation of parking meters is necessary to aid in the regulation and control of parking vehicles.~~
- ~~(3)~~(2) Each parking meter shall bear thereon a legend indicating the days and hours when the requirement to deposit coins therein applies, the value of the coin to be deposited and the period of time during which parking is permitted in at the parking meter zone in which such meter is located.
- ~~(4)~~(3) No person shall park a vehicle in any parking space to which a parking meter has been installed during the restricted and regulated time applicable to the parking meter zone unless a coin or coins of United States currency of the appropriate denomination shall have been deposited therein, or shall have been previously deposited therein for an unexpired interval of time, and said meter has been placed in operation.
- (H) Opening doors on traffic side. No person shall open the door of a motor vehicle on the side available to moving traffic unless and until it is reasonably safe to do so and can be done without interfering with the movement of other traffic, nor shall any person leave a door open on the side of a motor vehicle available to moving traffic for a period of time longer than necessary to load or unload passengers as set forth in section 4511.70 of the Revised Code.
- (I) Unattended vehicles; duty to lock ignition, remove key, set brake, etc. No person driving or in charge of a motor vehicle shall permit it to stand unattended without first stopping the engine, locking the ignition, removing the key from the ignition, effectively setting the parking brake and, when the motor vehicle is standing upon any grade, turning the front wheels to the curb or side of the highway or roadway.

The requirements of this paragraph relating to the stopping of the engine, locking of the ignition and removing the key from the ignition of a motor vehicle shall not apply to an emergency vehicle or a public safety vehicle as set forth in section 4511.66.1 of the Revised Code.

AUTHORIZATION FOR CAPITAL PROJECTS

Project	Approved Amount	Funding Source		Requested Action
ATI - Resurface Garrison Circle East	\$0.085 M	State:	\$0.085 M	Enter into design contracts
ATI - Various Concrete Work	\$0.050 M	State:	\$0.050 M	Enter into design contracts
Atwell Hall - Roof Replacement	\$0.375 M	State:	\$0.375 M	Enter into design contracts
Bricker Hall - Roof Replacement	\$0.500 M	State:	\$0.500 M	Enter into design contracts
Campus Buildings - Elevator Hydraulic Cylinder Replacement	\$0.575 M	State:	\$0.575 M	Enter into design contracts
Campus Grounds - Neil Avenue Corridor	\$0.750 M	State:	\$0.750 M	Enter into design contracts
Comprehensive Cancer Center - Chiller Replacement	\$0.400 M	State:	\$0.400 M	Enter into design contracts
Doan Hall - Renovation Suite 236 PET/CT Unit	\$0.373 M	Dept:	\$0.373 M	Enter into design contracts
Kottman Hall 103 Classroom Renovation	\$0.608 M	State:	\$0.608 M	Enter into design contracts
Lima Campus - Campus Drive Resurface	\$0.055 M	State:	\$0.055 M	Enter into design contracts
Lima Campus - Galvin Hall 4th Floor Renovation	\$0.368 M	State:	\$0.368 M	Enter into design contracts
Lima Campus - Overflow Parking Lot Renovation	\$0.293 M	Dept:	\$0.293 M	Enter into design contracts
Parks Hall - Chiller Replacement	\$0.800 M	State:	\$0.800 M	Enter into design contracts
Townshend Hall - Roof Replacement	\$1.000 M	State:	\$1.000 M	Enter into design contracts
Tzagournis Medical Research Facility Room 190	\$0.357 M	Dept:	\$0.357 M	Enter into design contracts
Veterinary Hospital - Roof Replacement Phase II	\$0.650 M	State:	\$0.650 M	Enter into design contracts
Wiseman Hall - Buildout of 3rd Floor Shell Space	\$3.570 M	Dept:	\$3.570 M	Enter into design contracts

AUTHORIZATION FOR CAPITAL PROJECTS

Page 2

James Cancer Hospital - 3 East and 3 South	\$2.134 M	Dept:	\$2.134 M	Enter into construction contract
Larkins Natatorium Scoreboard	\$0.530 M	Dept:	\$0.530 M	Enter into construction contract
Neil Avenue Garage (a)	\$14.838 M	Dept:	\$14.838 M	Enter into construction contract
OARDC - Piketon Training and Development Center	\$3.090 M	State:	\$0.900 M	Enter into construction contract
		Federal:	\$2.190 M	
Ohio 4-H Center (b)	\$10.000 M	Dept:	\$10.000 M	Enter into construction contract
Total by Source:	\$41.401 M	Dept:	\$32.095 M	
		State:	\$7.116 M	
		Federal:	\$2.190 M	
Total			\$41.401 M	

- (a) Project previously was approved for construction total of \$11,809,364; project cost increase of \$3,029,107 to expand parking capacity is submitted for approval.
- (b) Project previously was approved for construction total of \$9,100,000; project scope increase of \$900,000 is submitted for approval.



Requesting Agency(s): ATI-ADMINISTRATIVE SUPPORT

Location(s): Various Locations-ATI

Gross Sq. Ft.0 Age:

Description: Seal cracks, polypropylene fabric with seal coat and resurface with 1.5" of asphalt and reline including the east parking lot.

Project Team:

Project Information:

Facility Planner: Is Unassigned

 Project Captain: Marjory Spangler
 (spangler.40@osu.edu)
 Project Assistant: Is Unassigned

 Field Coordinator: Is Unassigned

Source of Funds:	Original	Revised	Uses of Funds:	As Designed	As Bid	Completion
HB675 Regional Basic Renovation	\$85,000.00	\$85,000.00	Total:			
Total:	\$85,000.00	\$85,000.00				

Schedule:	Projected	Revised	Actual
Planning			
Arch/Engr Approved by B/T	05/30/2003		
Bidding Approved B/T	09/05/2003		
Design			
Schematic Design Approval	06/30/2003		
Design Dev Document Approval	06/30/2003		
Construction Document Approval	07/28/2003		
Bidding			
Bid Opening	08/28/2003		
Construction			
Award of Contracts	10/28/2003		
Construction Start	11/01/2003		
Completion	12/15/2003		

ATI - Resurface Garrison Circle East

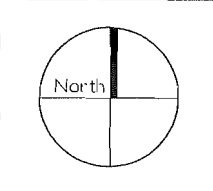
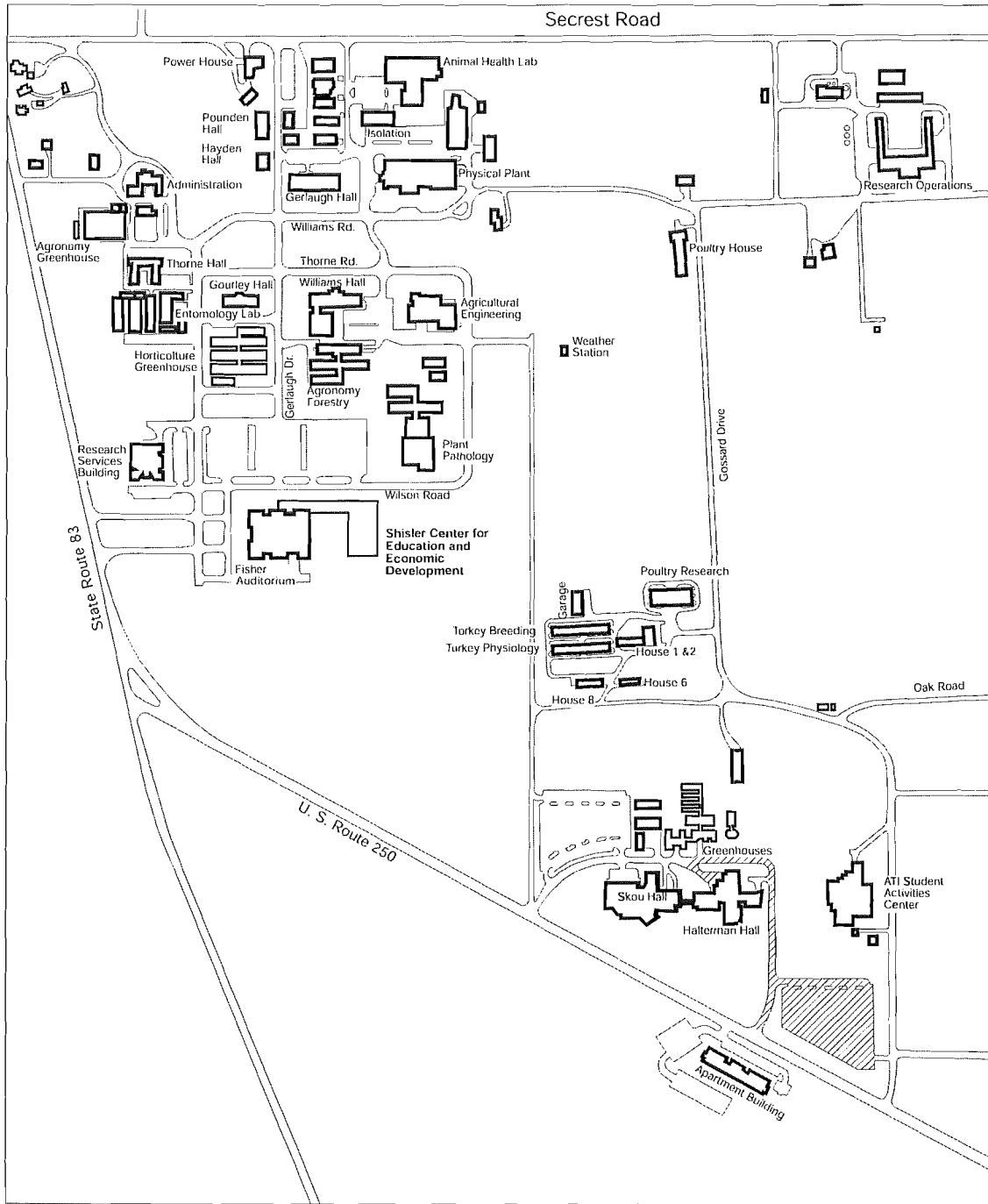



ATI - Various Concrete Work

315-2003-954

Requesting Agency(s): ATI-ADMINISTRATIVE SUPPORT

Location(s): SKOU HALL, WILLIAM JOHN

Gross Sq. Ft.72,105 Age: 1978

Location(s): Various Locations-ATI

Gross Sq. Ft.0 Age:

Description: Replace pad at Skou Hall south entry, replace Bee Lab entrance, and replace miscellaneous sidewalks.

Project Team:

Project Information:

Facility Planner: Is Unassigned

Project Captain: Marjory Spangler
(spangler.40@osu.edu)

Project Assistant: Is Unassigned

Field Coordinator: Is Unassigned

Source of Funds:	Original	Revised	Uses of Funds:	As Designed	As Bid	Completion
HB640 Regional Basic Renovations	\$50,000.00	\$50,000.00				
Total:	\$50,000.00	\$50,000.00	Total:			

Schedule:	Projected	Revised	Actual
Planning			
Arch/Engr Approved by B/T	05/30/2003		
Bidding Approved B/T	09/05/2003		
Design			
Schematic Design Approval	06/30/2003		
Design Dev Document Approval	06/30/2003		
Construction Document Approval	07/28/2003		
Bidding			
Bid Opening	08/28/2003		
Construction			
Award of Contracts	10/28/2003		
Construction Start	11/01/2003		
Completion	12/15/2003		

ATI - Various Concrete Work

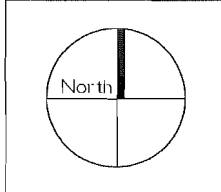
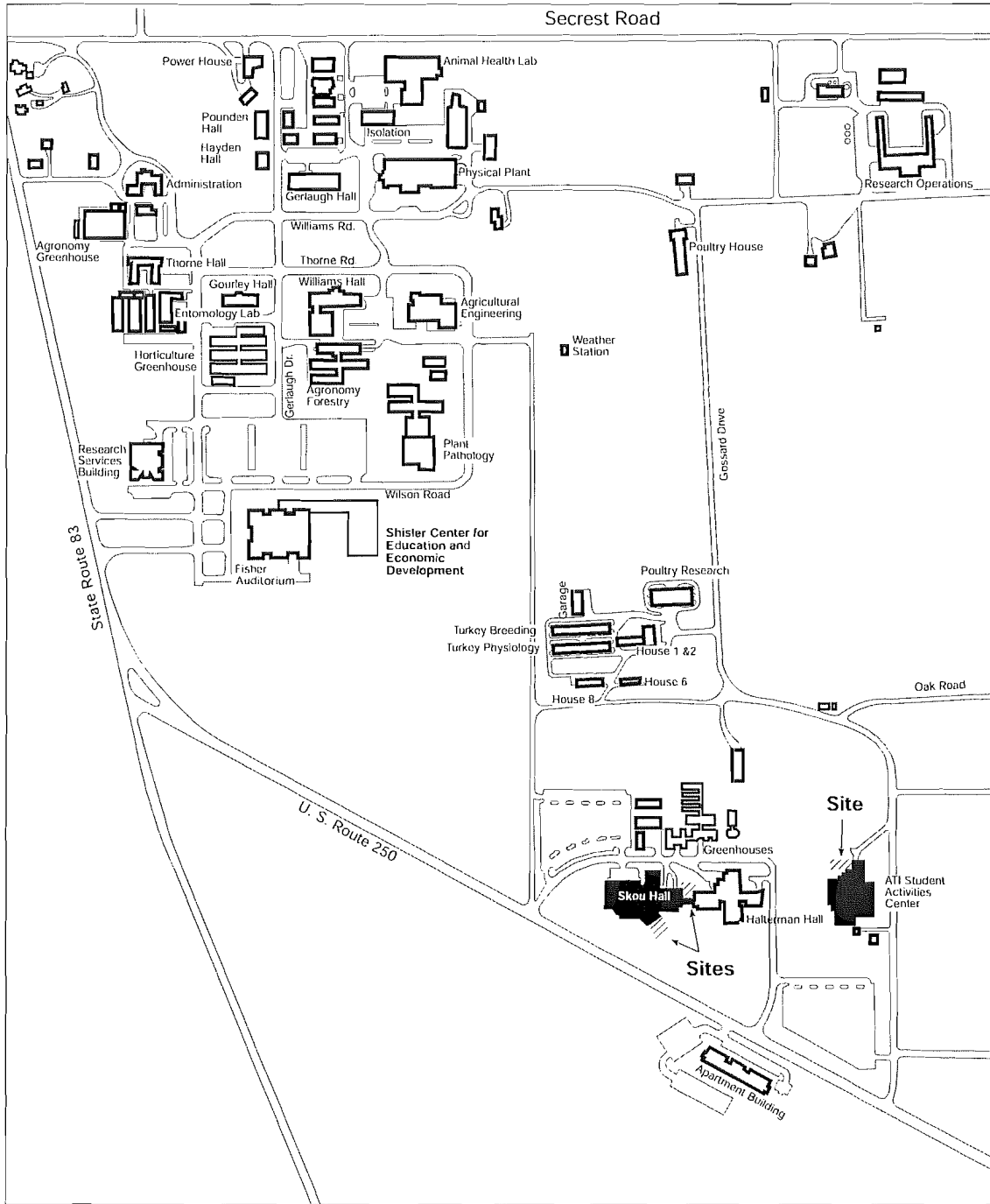



Atwell Hall - Roof Replacement
315-2003-929

Requesting Agency(s): PHYSICAL FACILITIES

Location(s): ATWELL HALL, ROBERT J (ALLIED MED)

Gross Sq. Ft. 97,641 Age: 1971

Description: Completely remove 24,300 sq ft of coal tar built-up roof system on Atwell Hall. Check lightweight concrete for damage and moisture. Remove and replace damaged fill. Install a vapor barrier over lightweight fill. Install a modified bitumen roof system over 2" of insulation. Replace aluminum counterflashing and reuse aluminum cap at parapets.

Project Team:

Project Information:

Facility Planner: Is Unassigned

Project Captain: Brett Garrett

Project Assistant: Is Unassigned

Field Coordinator: Is Unassigned

Source of Funds:	Original	Revised	Uses of Funds:	As Designed	As Bid	Completion
HB675 Columbus Basic Renovation	\$375,000.00	\$375,000.00				
Total:	\$375,000.00	\$375,000.00	Total:			

Schedule:	Projected	Revised	Actual
Planning			
Arch/Engr Approved by B/T	05/02/2003		
Bidding Approved B/T	04/02/2004		
Design			
Design Dev Document Approval	01/18/2004		
Construction Document Approval	02/17/2004		
Bidding			
Bid Opening	04/17/2004		
Construction			
Construction Start	06/16/2004		
Completion	10/14/2004		
Report of Award to B/T	12/03/2004		

Atwell Hall - Roof Replacement

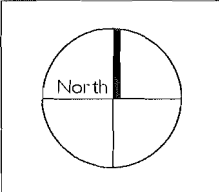
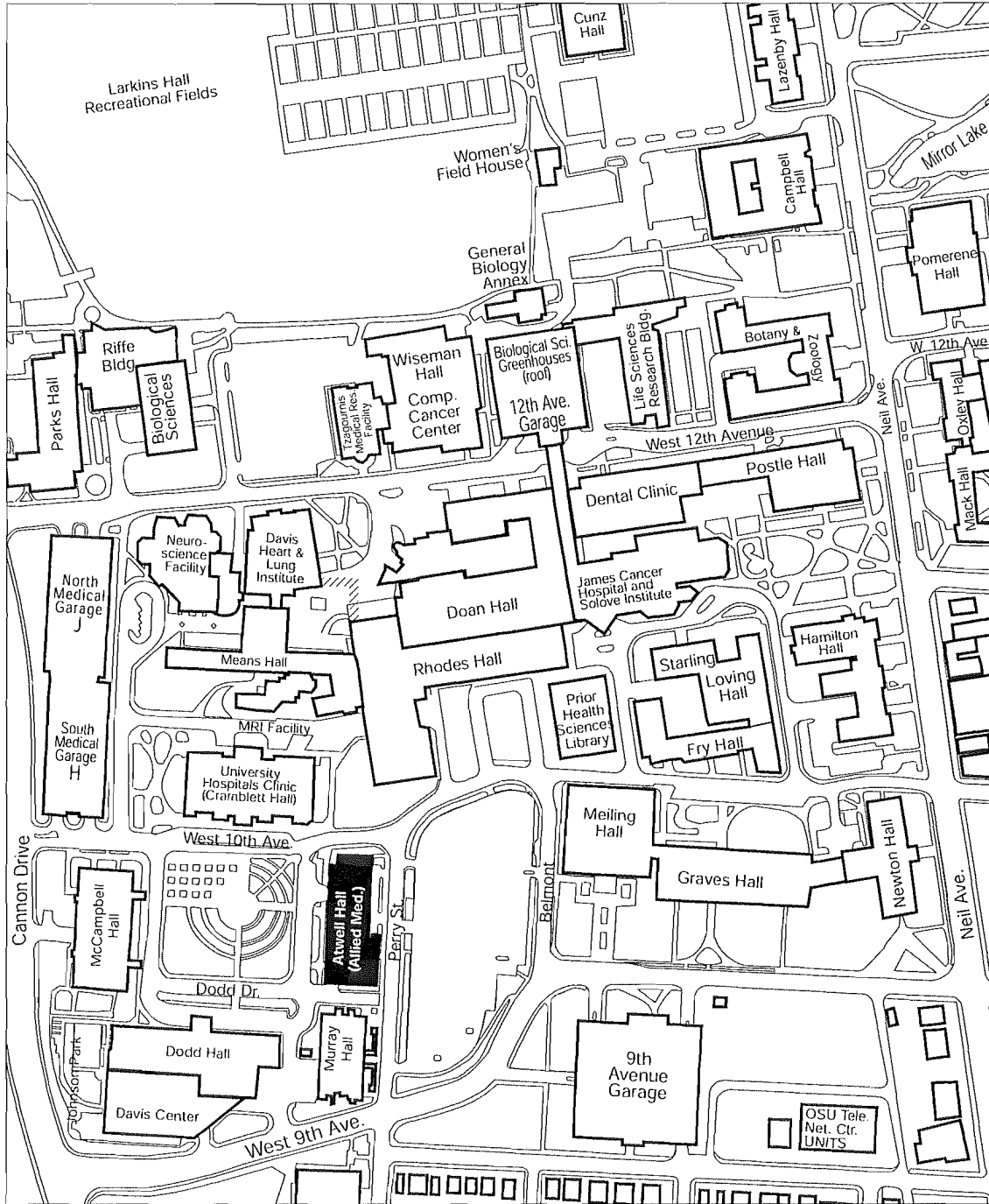



Bricker Hall - Roof Replacement

315-2003-931

Requesting Agency(s): PHYSICAL FACILITIES

Location(s): BRICKER HALL, JOHN W

Gross Sq. Ft. 73,914 Age: 1924

Description: A standing seam copper roof was installed on Bricker Hall in 1949 in place of the skylights. The perimeter roofing has a nearly vertical roof surface facing the interior roof sections. These walls are covered with composition roofing that is in poor condition. The gutters surrounding the roof are composed of built-up roofing. Roof replacement project to include the perimeter roof, gutters and composition roofing.

Project Team:

Facility Planner: Is Unassigned
 Project Captain: Brett Garrett
 Project Assistant: Is Unassigned
 Field Coordinator: Is Unassigned

Project Information:

Source of Funds:	Original	Revised	Uses of Funds:	As Designed	As Bid	Completion
HB675 Columbus Basic Renovation	\$500,000.00	\$500,000.00				
Total:	\$500,000.00	\$500,000.00	Total:			

Schedule:	Projected	Revised	Actual
Planning			
Arch/Engr Approved by B/T	05/02/2003		
Bidding Approved B/T	03/05/2004		
Design			
Design Dev Document Approval	01/18/2004		
Construction Document Approval	02/17/2004		
Bidding			
Bid Opening	04/02/2004		
Construction			
Construction Start	06/01/2004		
Completion	09/29/2004		
Report of Award to B/T	12/03/2004		

Bricker Hall - Roof Replacement

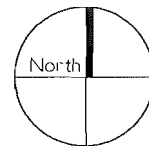
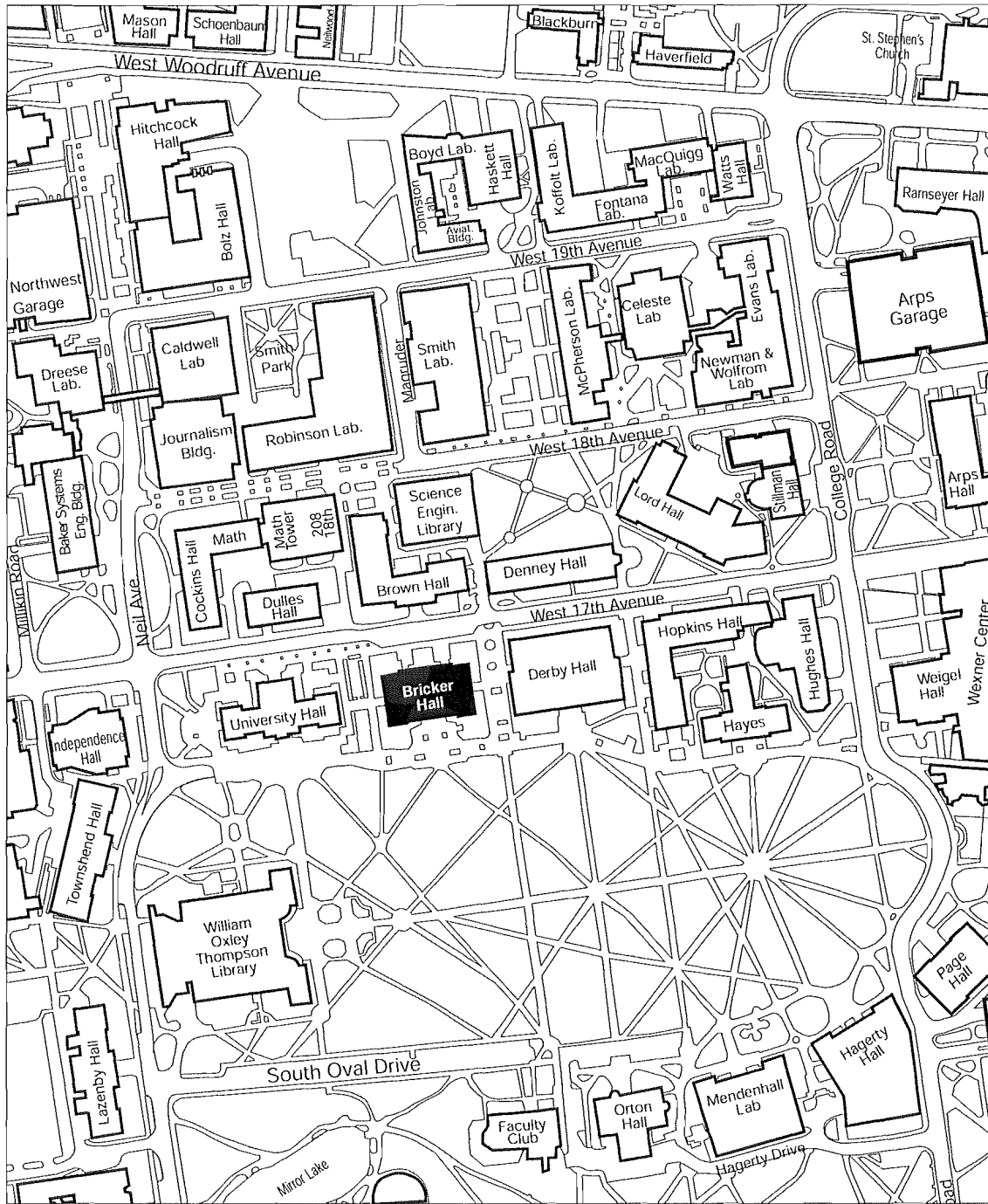



Campus Buildings - Elevator Hydraulic Cylinder Replacement

315-2003-910

Requesting Agency(s): PHYSICAL FACILITIES

Location(s): Site - See Comments.

Gross Sq. Ft.0 Age:

Description: Prior to the mid 1970s the hydraulic elevator cylinder had a single bottom design. This design was susceptible to corrosion, electrolysis and failure due to the wearing away of the metal. Hydraulic cylinder failure causes uncontrolled elevator descent. Replace all single shell design with double bulk head cylinder with PVC piping to meet current code.

Project Team:

Project Information:

Facility Planner: Is Unassigned

Project Captain: Sam Alabi
(alabi.1@osu.edu)

Project Assistant: Is Unassigned

Field Coordinator: Is Unassigned

Source of Funds:	Original	Revised	Uses of Funds:	As Designed	As Bid	Completion
HB675 Columbus Basic Renovation	\$575,000.00	\$575,000.00				
Total:	\$575,000.00	\$575,000.00	Total:			

Schedule:	Projected	Revised	Actual
Planning			
Arch/Engr Approved by B/T	04/04/2003		
Bidding Approved B/T	03/05/2004		
Design			
Design Dev Document Approval	12/01/2003		
Construction Document Approval	02/01/2004		
Bidding			
Bid Opening	04/01/2004		
Construction			
Construction Start	06/01/2004		
Completion	10/30/2004		
Report of Award to B/T	12/03/2004		

Campus Buildings - Elevator Hydraulic Cylinder Replacement

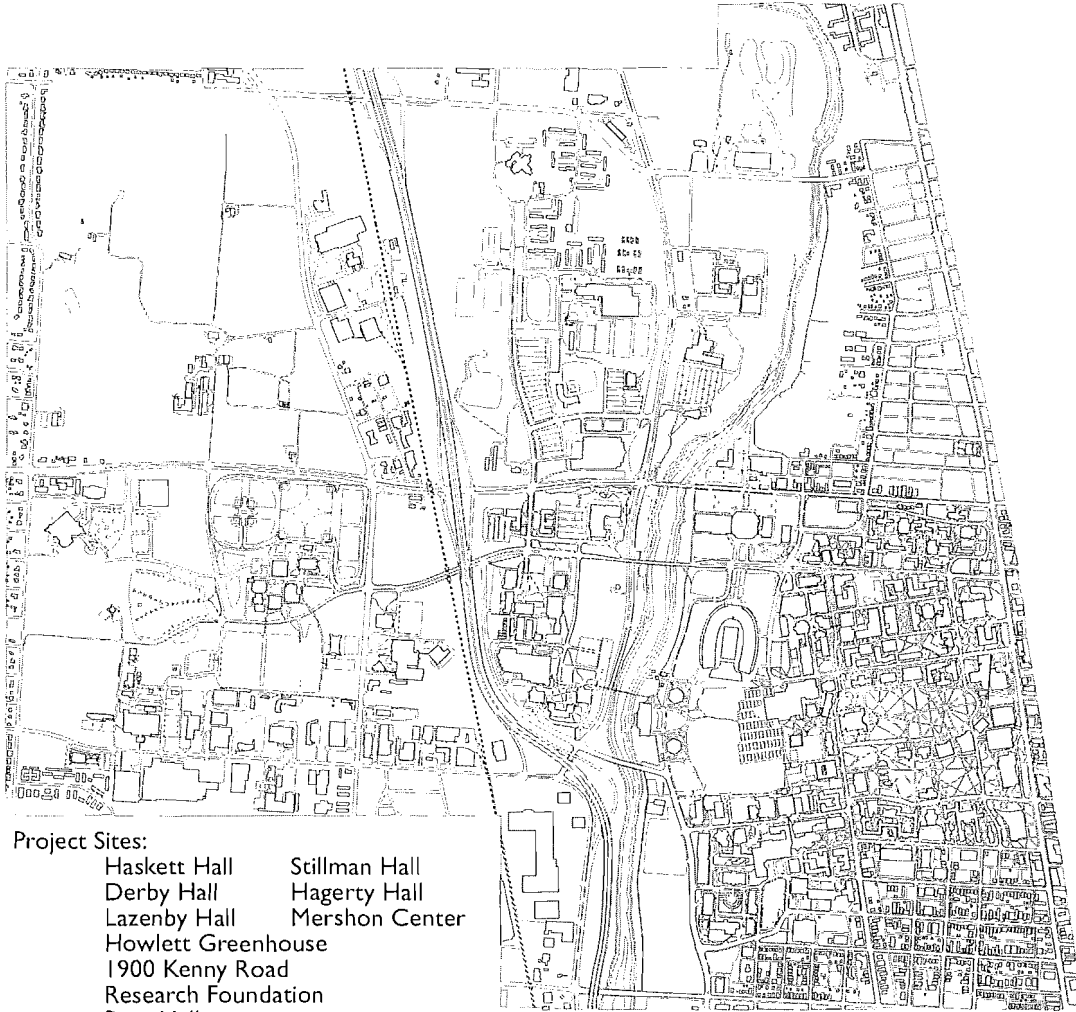

Project Sites:

Haskett Hall	Stillman Hall
Derby Hall	Hagerty Hall
Lazenby Hall	Mershon Center
Howlett Greenhouse	
1900 Kenny Road	
Research Foundation	
Page Hall	
Smith Lab	
Brown Hall	
Hitchcock Hall	
Graves Hall	
Meiling Hall	
Mount Hall	
Veterinary Hospital	

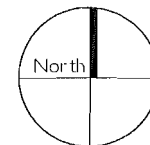



Requesting Agency(s): PHYSICAL FACILITIES

Location(s): Unidentified Street-Col.

Gross Sq. Ft.0 Age:

Description: Street and sidewalk upgrades to improve traffic flow and enhance pedestrian safety. Includes signaling, lighting, bus drop-off, and planting.

Project Team:

Project Information:

Facility Planner: Is Unassigned

Project Captain: Gary Collier
(collier.26@osu.edu)
Project Assistant: Is Unassigned

Field Coordinator: Is Unassigned

Source of Funds:	Original	Revised	Uses of Funds:	As Designed	As Bid	Completion
HB675 Columbus Basic Renovation	\$750,000.00	\$750,000.00	Total:			
Total:	\$750,000.00	\$750,000.00				

Schedule:	Projected	Revised	Actual
Planning			
Arch/Engr Approved by B/T	05/02/2003		
Bidding Approved B/T	02/06/2004		
Design			
Schematic Design Approval	08/20/2003		
Design Dev Document Approval	10/20/2003		
Construction Document Approval	12/12/2003		
Bidding			
Bid Opening	02/12/2004		
Construction			
Construction Start	06/23/2004		
Completion	10/27/2004		
Report of Award to B/T	12/03/2004		

Campus Grounds - Neil Avenue Corridor

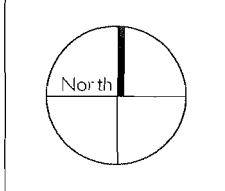
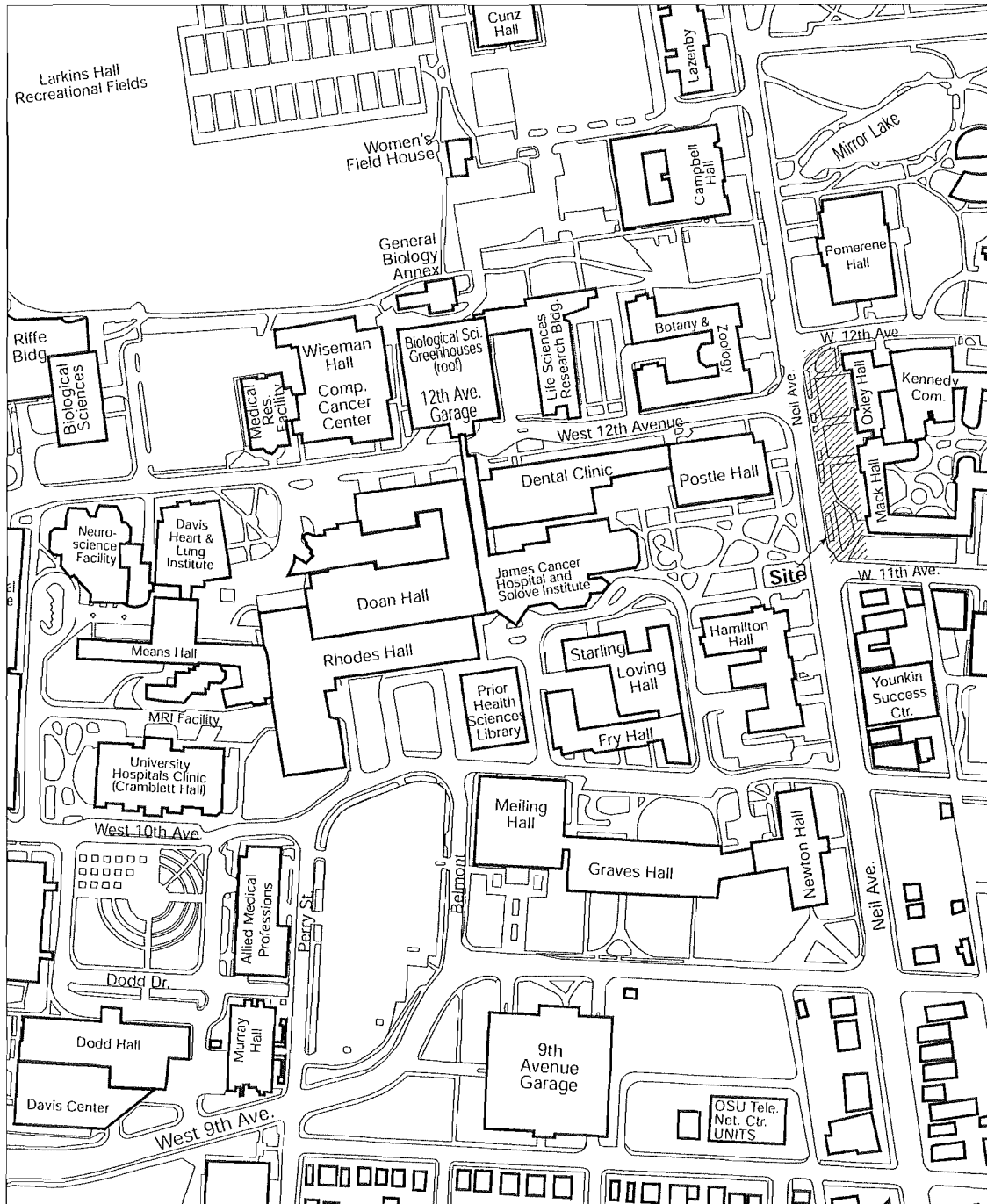



Comprehensive Cancer Center - Chiller Replacement

315-2003-921

Requesting Agency(s): PHYSICAL FACILITIES

Location(s): COMPREHENSIVE CANCER CENTER, OSU

Gross Sq. Ft. 30,907 Age: 1980

Description: Replace the existing 22 year old, 163 ton R-11 Trane Chiller in Room 520M, Comprehensive Cancer Center.

Project to include correct sizing of cooling loads, configuration, modification or replacement as appropriate, including cooling tower, circulating equipment and associated piping.

Project Team:

Facility Planner: Is Unassigned

Project Captain: Jerry Bender
(bender.3@osu.edu)

Project Assistant: Is Unassigned

Field Coordinator: Is Unassigned

Project Information:

Source of Funds:	Original	Revised	Uses of Funds:	As Designed	As Bid	Completion
HB675 Columbus Basic	\$400,000.00	\$400,000.00				
Renovation			Total:			
Total:	\$400,000.00	\$400,000.00				

Schedule:	Projected	Revised	Actual
Planning			
Arch/Engr Approved by B/T	05/02/2003		
Bidding Approved B/T	05/07/2004		
Design			
Schematic Design Approval	08/30/2003		
Design Dev Document Approval	11/01/2003		
Construction Document Approval	03/01/2004		
Bidding			
Bid Opening	06/01/2004		
Construction			
Construction Start	11/15/2004		
Report of Award to B/T	12/03/2004		
Completion	03/30/2005		



Doan Hall - Renovation Suite 236 PET/CT Unit

315-2003-959

Requesting Agency(s): UNIVERSITY HOSPITALS

Location(s): DOAN HALL, CHARLES AUSTIN

Gross Sq. Ft.669,869 Age: 1951

Description: Renovate a section of the Radiology files room 236, in Doan Hall to install a PET/CT Imaging unit.

Project Team:

Facility Planner: Is Unassigned
Project Captain: Richard Van Deusen (van-deusen.2@osu.edu)
Project Assistant: Andrea Thimmes (thimmes.5@osu.edu)
Field Coordinator: Is Unassigned

Project Information:

Formerly 50700-R034555
Preliminary project budget: \$372,874

Source of Funds: Original Revised Uses of Funds: As Designed As Bid Completion

Total:

Doan Hall - Renovation Suite 236 PET/CT Unit

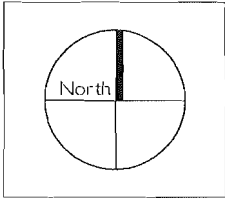
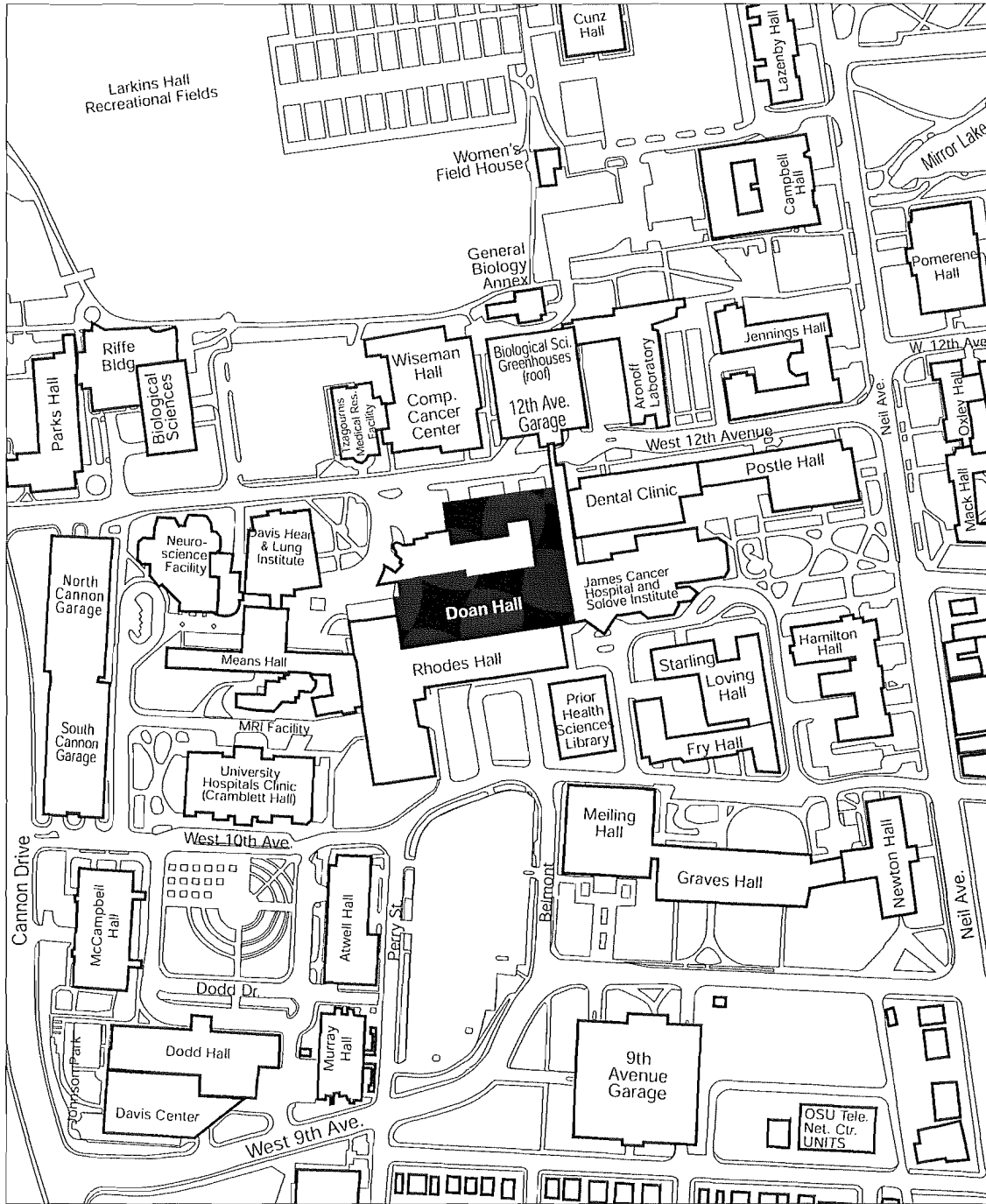



Kottman Hall - 103 Classroom Renovation

315-2003-947

Requesting Agency(s): CLASSROOM POOL

Location(s): KOTTMAN HALL, ROY M

Gross Sq. Ft.166,391 Age: 1981

Description: Patch, rehabilitate, and paint walls and ceilings; new seating and 6 wheelchair stations, carpet, light fixtures and controls, new chalkboard, sound system speakers with wiring and controls, new projection screen, new video/date projection system, ADA signage, refurbish control room to included dedicated electrical circuits, system controls, new projection window and paint.

Project Team:

Project Information:

Facility Planner: Is Unassigned

Project Captain: Is Unassigned

Project Assistant: Is Unassigned

Field Coordinator: Is Unassigned

Source of Funds:	Original	Revised	Uses of Funds:	As Designed	As Bid	Completion
HB675 Columbus Basic Renovation	\$607,833.00	\$607,833.00				
Total:	\$607,833.00	\$607,833.00	Total:			

Kottman Hall - 103 Classroom Renovation

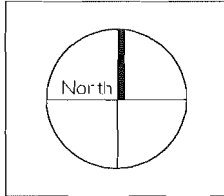
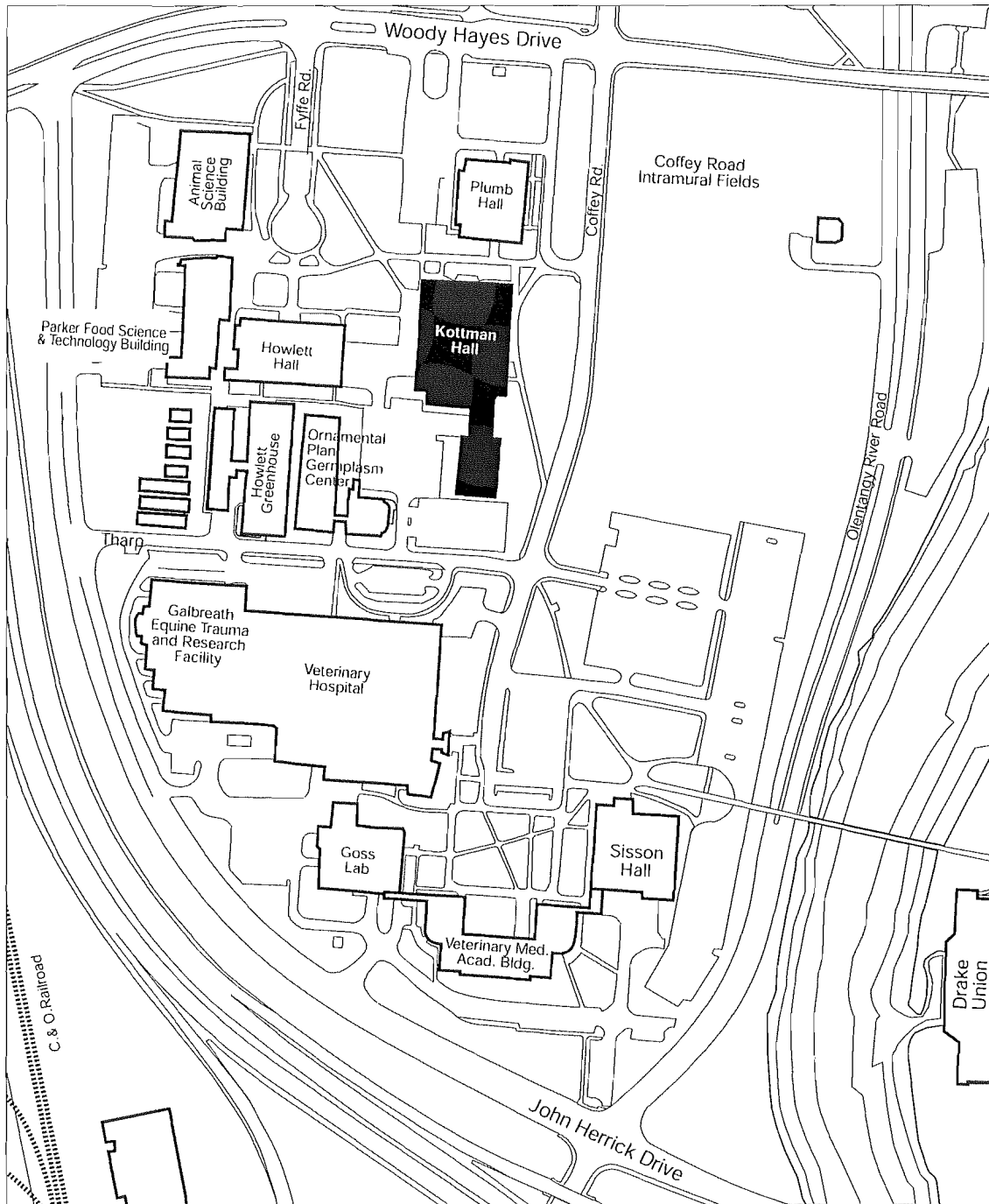



Lima Campus - Campus Drive Resurface

315-2003-977

Requesting Agency(s): LIMA CAMPUS

Location(s): Various Locations-Lima

Gross Sq. Ft.0 Age:

Description: Grind and resurface Campus Drive, between Biddle Drive and the classroom trailers, as well as the parking lots adjacent to the Public Service Building and the maintenance shops.

Project Team:

Project Information:

Facility Planner: Is Unassigned

Project Captain: Christine Lawson
(lawson.132@osu.edu)

Project Assistant: Leeanne Chandler
(chandler.63@osu.edu)

Field Coordinator: Is Unassigned

Source of Funds:	Original	Revised	Uses of Funds:	As Designed	As Bid	Completion
HB640 Regional Basic Renovations	\$54,978.00	\$54,978.00				
Total:	\$54,978.00	\$54,978.00	Total:			

Schedule:	Projected	Revised	Actual
Planning			
Arch/Engr Approved by B/T	05/30/2003		
Bidding Approved B/T	08/02/2003		
Bidding			
Bid Opening	08/21/2003		
Construction			
Award of Contracts	10/17/2003		
Construction Start	10/20/2003		
Completion	11/21/2003		

Lima Campus - Campus Drive Resurface

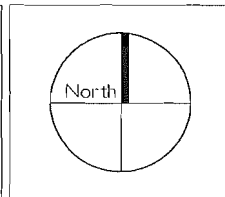
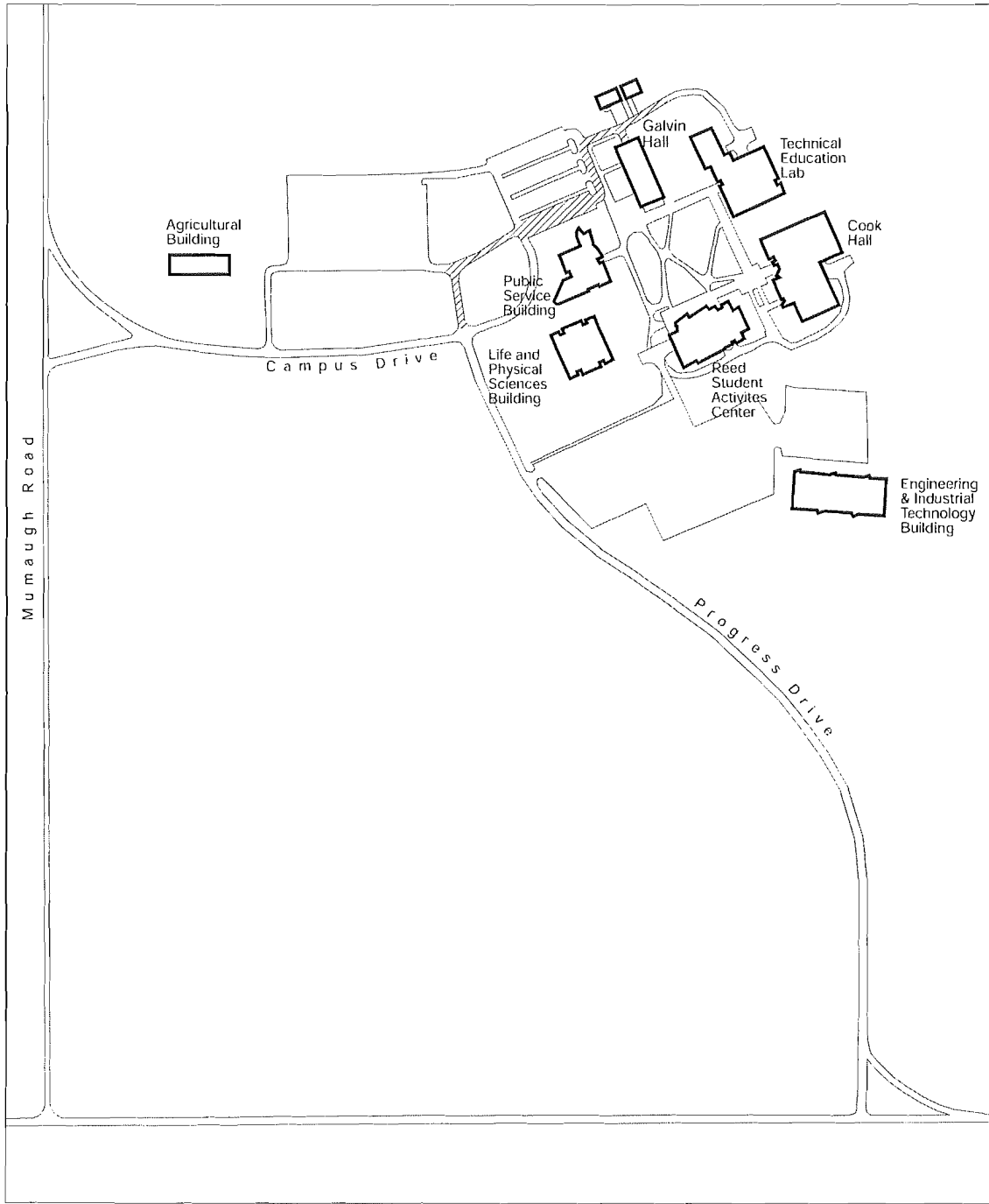



Lima Campus - Galvin Hall 4th Floor Renovation

315-2003-940

Requesting Agency(s): LIMA CAMPUS

Location(s): GALVIN HALL

Gross Sq. Ft. 81,719 Age: 1966

Description: Renovation of approximately 5,000 square feet of administrative and instructional space of the north portion of Galvin Hall on the Lima Campus.

Project Team:

Facility Planner: Is Unassigned

Project Captain: Christine Lawson
(lawson.132@osu.edu)

Project Assistant: Leeanne Chandler
(chandler.63@osu.edu)

Field Coordinator: Is Unassigned

Project Information:

Preliminary project budget \$367,657

Source of Funds:	Original	Revised	Uses of Funds:	As Designed	As Bid	Completion
HB850 Line Item	\$367,656.80	\$367,656.80				
Appropriation			Total:			
Total:	\$367,656.80	\$367,656.80				

Schedule:	Projected	Revised	Actual
Planning			
Arch/Engr Approved by B/T	05/02/2003	07/01/2003	

Lima Campus - Galvin Hall Fourth Floor Renovation

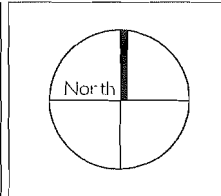
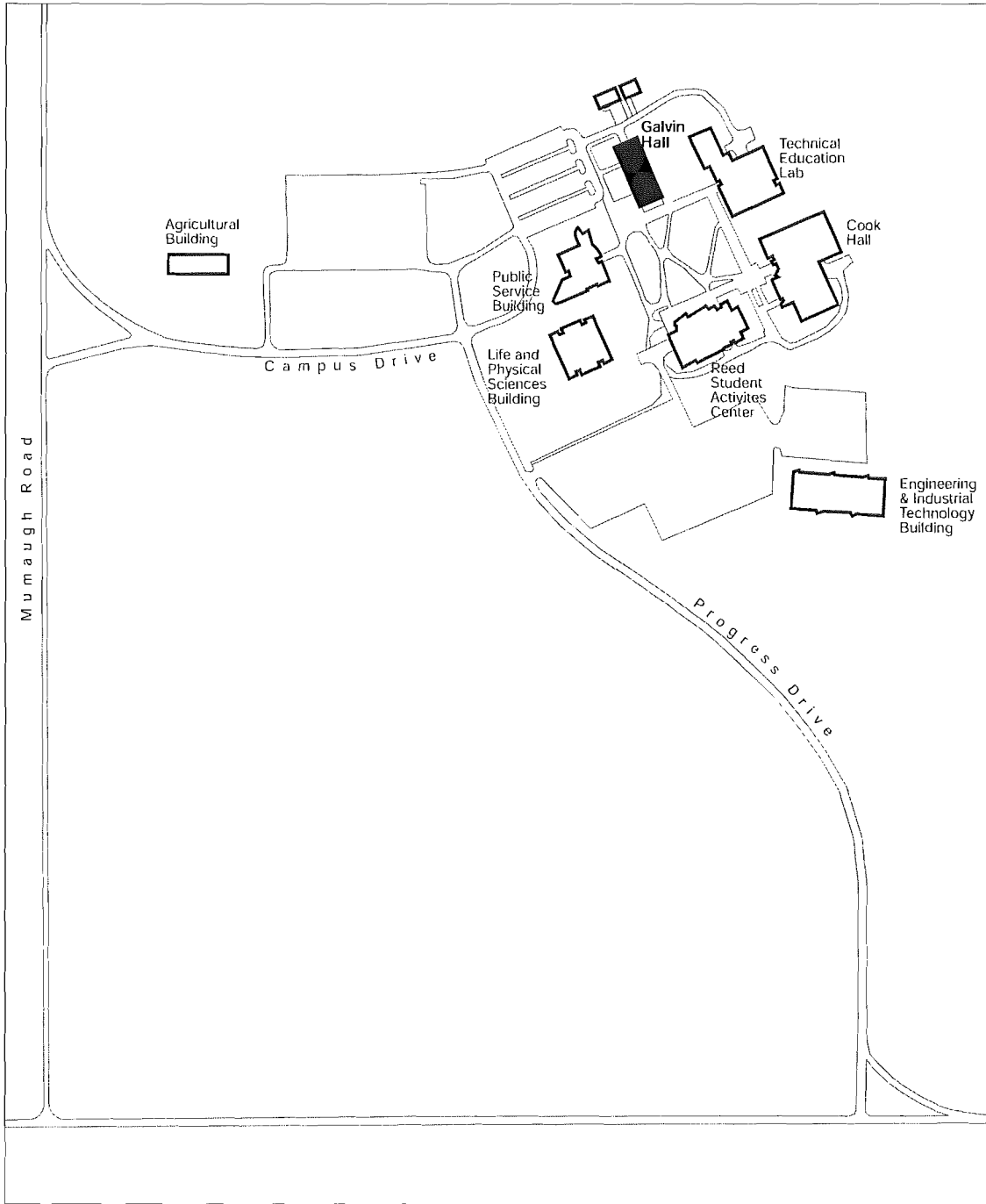



Lima Campus - Overflow Parking Lot Renovation

315-2003-961

Requesting Agency(s): LIMA CAMPUS

Location(s): Various Locations-Lima

Gross Sq. Ft.0 Age:

Description: Renovate an existing 3 acre gravel overflow parking area located on the southwest side of Campus Drive, directly across from the Reed parking lot. The project will include improving the existing drainage and gravel base course, relocation of the parking lot entry, paving, lining, curbs and limited landscaping.

Project Team:

Project Information:

Facility Planner: Is Unassigned

Project Captain: Christine Lawson
(lawson.132@osu.edu)

Project Assistant: Leeanne Chandler
(chandler.63@osu.edu)

Field Coordinator: Is Unassigned

Source of Funds:	Original	Revised	Uses of Funds:	As Designed	As Bid	Completion
General Funds-Lima	\$292,991.00	\$292,991.00				
Total:	\$292,991.00	\$292,991.00	Total:			

Schedule:	Projected	Revised	Actual
Planning			
Arch/Engr Approved by B/T	05/30/2003		
Bidding Approved B/T	01/08/2004		
Design			
Arch/Engr Contract	08/01/2003		
Construction Document Approval	12/01/2003		
Bidding			
Bid Opening	01/08/2004		
Construction			
Award of Contracts	03/05/2004		
Construction Start	03/08/2004		
Completion	07/30/2004		

Lima Campus -Overflow Parking Lot Renovation

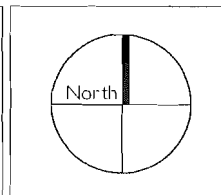
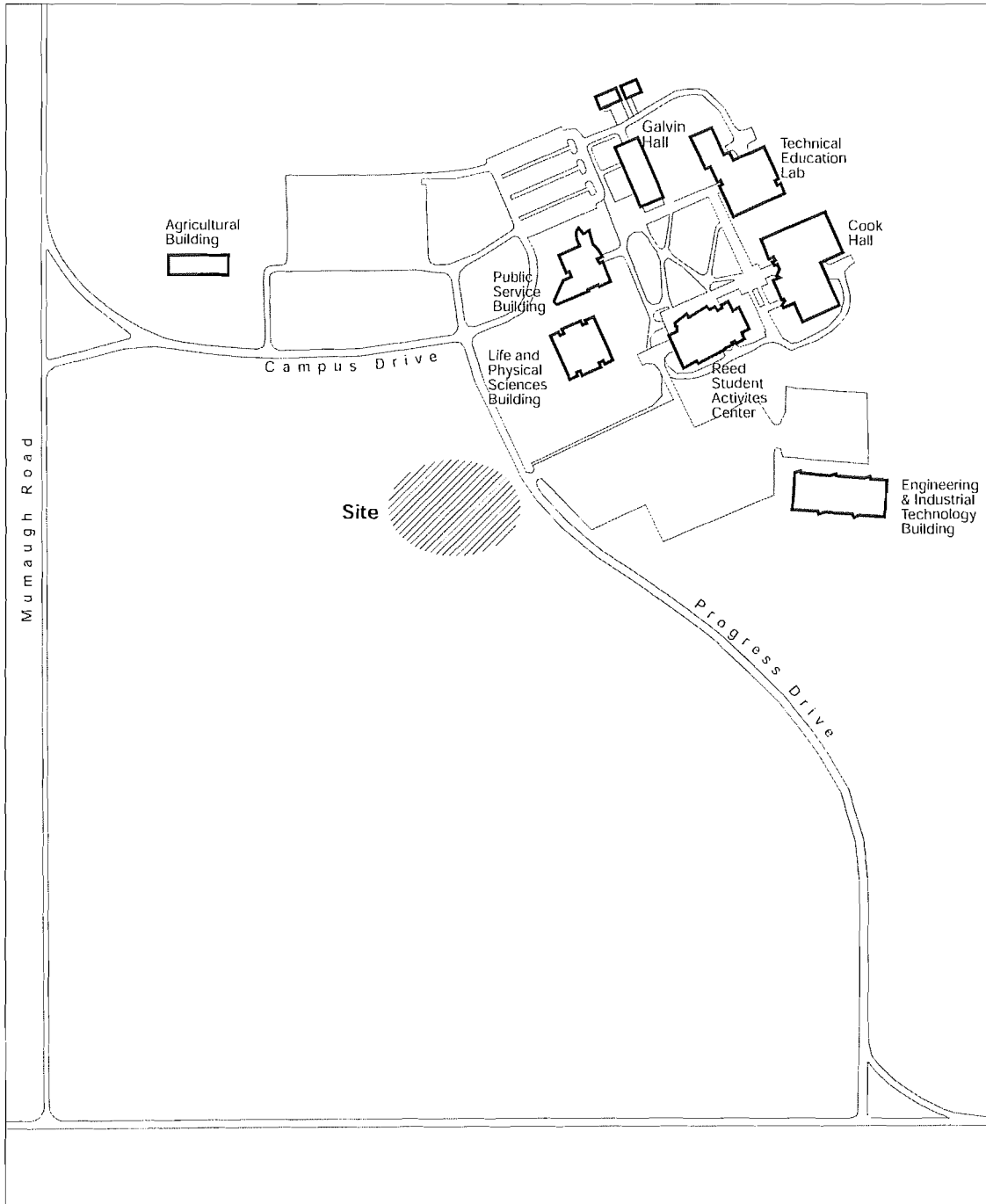



Requesting Agency(s): PHYSICAL FACILITIES

Location(s): PARKS HALL, LLOYD M.

Gross Sq. Ft. 119,366 Age: 1967

Description: Replace the existing 26 year old 400 ton R-11 York Chiller in Parks Hall. Project includes correct sizing of cooling loads, configuration, modification or replacement as appropriate, including the cooling tower, circulating equipment and associated piping.

Project Team:

Project Information:

Facility Planner: Is Unassigned

Project Captain: Jerry Bender
(bender.3@osu.edu)

Project Assistant: Is Unassigned

Field Coordinator: Is Unassigned

Source of Funds:	Original	Revised	Uses of Funds:	As Designed	As Bid	Completion
HB675 Columbus Basic Renovation	\$800,000.00	\$800,000.00				
Total:	\$800,000.00	\$800,000.00	Total:			

Schedule:	Projected	Revised	Actual
Planning			
Arch/Engr Approved by B/T	06/06/2003		
Bidding Approved B/T	05/07/2004		
Design			
Schematic Design Approval	08/30/2003		
Design Dev Document Approval	11/01/2003		
Construction Document Approval	03/01/2004		
Bidding			
Bid Opening	06/01/2004		
Construction			
Construction Start	11/15/2004		
Report of Award to B/T	12/03/2004		
Completion	03/30/2005		

Parks Hall - Chiller Replacement

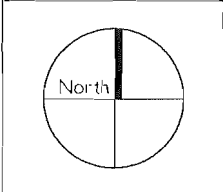
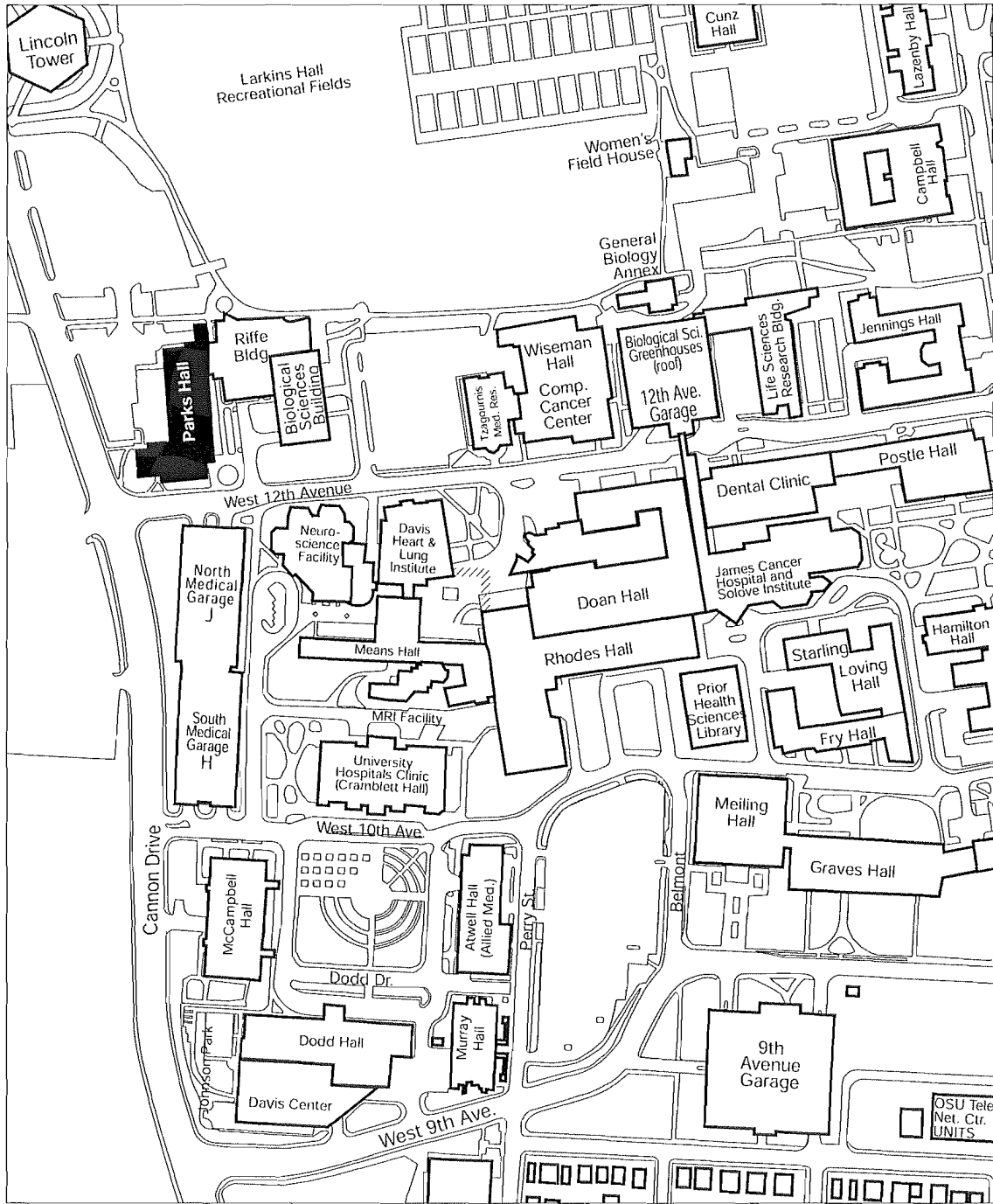



Townshend Hall - Roof Replacement
315-2003-936

Requesting Agency(s): PHYSICAL FACILITIES

Location(s): TOWNSHEND HALL, NORTON STRANGE

Gross Sq. Ft. 64,173 Age: 1898

Description: This project would remove the existing spanish tile and underlayment of Townshend Hall roof, replace approximately 30% of the wood decking and 50% of the wood supports to the roof's eaves, and install a new tile roof system.

Project Team:

Project Information:

Facility Planner: Is Unassigned
 Project Captain: Brett Garrett
 Project Assistant: Is Unassigned
 Field Coordinator: Is Unassigned

Source of Funds:	Original	Revised	Uses of Funds:	As Designed	As Bid	Completion
HB675 Columbus Basic Renovation	\$1,000,000.00	\$1,000,000.00				
Total:	\$1,000,000.00	\$1,000,000.00	Total:			

Schedule:	Projected	Revised	Actual
Planning			
Arch/Engr Approved by B/T	06/06/2003		
Bidding Approved B/T	03/05/2004		
Design			
Design Dev Document Approval	02/02/2004		
Construction Document Approval	03/03/2004		
Bidding			
Bid Opening	04/02/2004		
Construction			
Construction Start	06/16/2004		
Completion	11/13/2004		
Report of Award to B/T	12/03/2004		

Townshend Hall - Roof Replacement

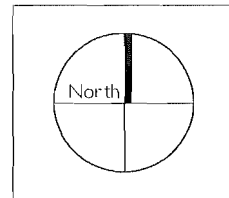
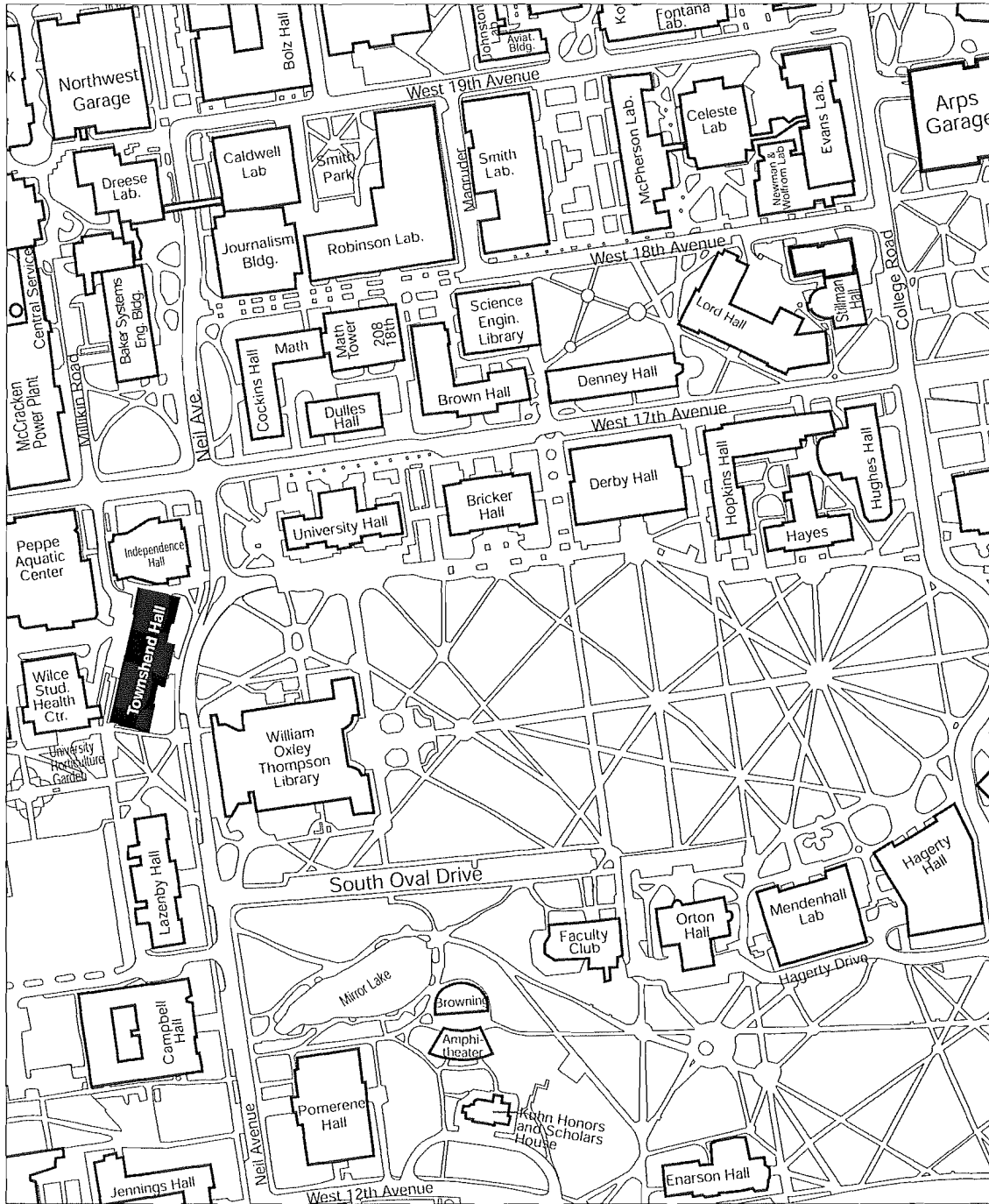



Tzagournis Medical Research Facility - Room 190
315-2003-901

Requesting Agency(s): MEDICINE AND PUBLIC HEALTH ADMIN

Location(s): TZAGOURNIS MEDICAL RESEARCH FACILITY

Gross Sq. Ft. 78,705 Age: 1994

Description: Renovate Room 190 of TMRF to house an animal MRI.
OFP #02-157

Project Team:

Facility Planner: Is Unassigned

Project Captain: Richard Van Deusen
(van-deusen.2@osu.edu)
Project Assistant: Andrea Thimmes
(thimmes.5@osu.edu)
Field Coordinator: Is Unassigned

Project Information:

Formerly known as 50700-R025199

Source of Funds:	Original	Revised	Uses of Funds:	As Designed	As Bid	Completion
Development-Medicine	\$357,490.00	\$357,490.00				
Total:	\$357,490.00	\$357,490.00	Total:			

Schedule:

	Projected	Revised	Actual
Planning			
6540 Received by OFP			11/13/2002
Request for Estimate Received - OA			11/13/2002
Request for Estimate Returned			12/19/2002

Tzagournis Medical Research Facility - Room 190

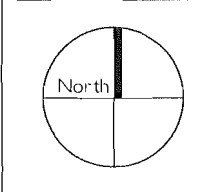
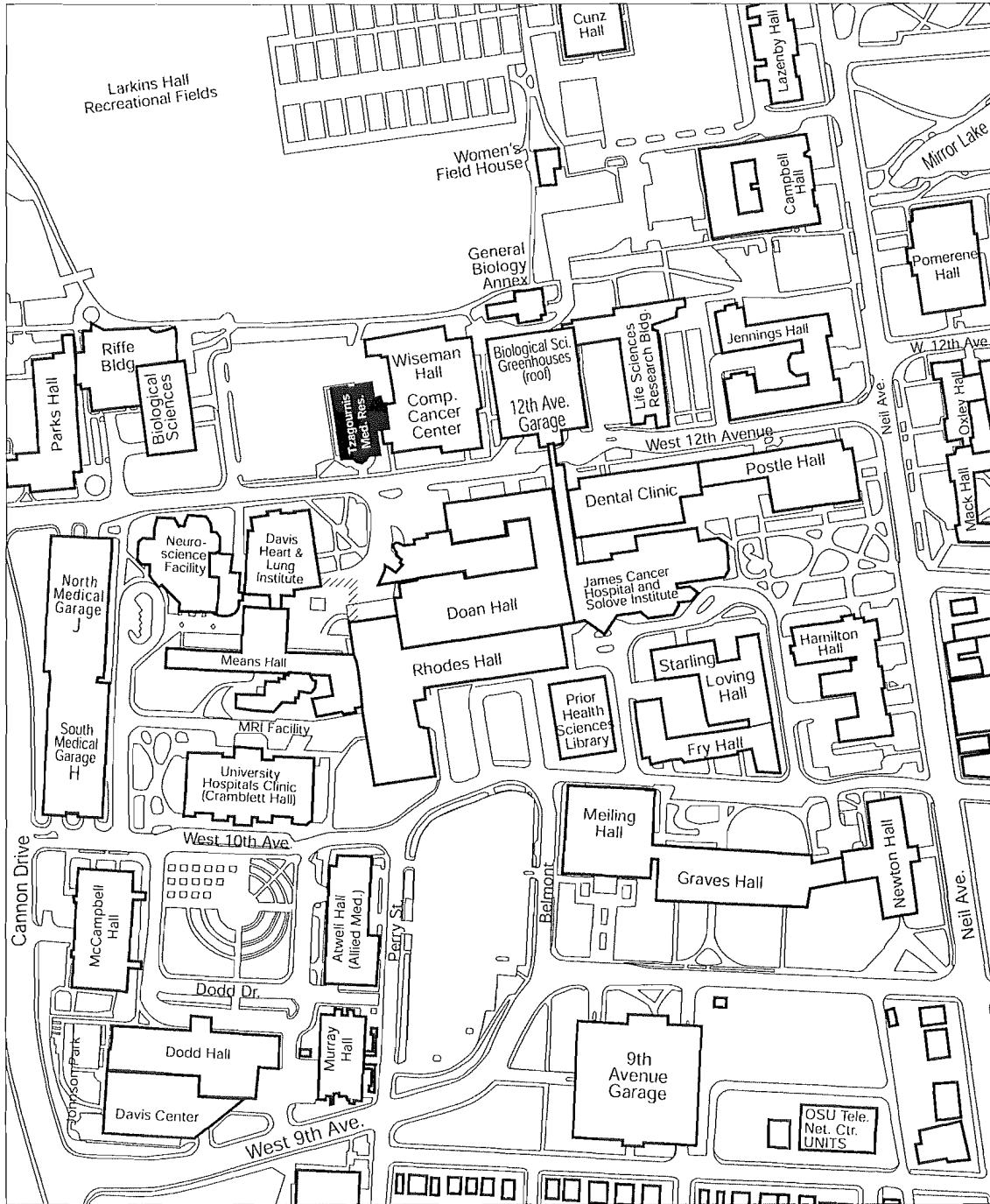



Veterinary Hospital - Roof Replacement Phase II
315-2003-933

Requesting Agency(s): PHYSICAL FACILITIES

Location(s): VETERINARY HOSPITAL

Gross Sq. Ft.222,496 Age: 1973

Description: Removal / replacement of the remaining Vet Hospital roof areas. The existing built-up roof needs to be removed and replaced with a new coal tar 4-ply roof system. (Reuse existing metal flashings and counterflashings.)

Project Team:

Project Information:

Facility Planner: Is Unassigned
Project Captain: Brett Garrett
Project Assistant: Is Unassigned
Field Coordinator: Is Unassigned

Source of Funds:	Original	Revised	Uses of Funds:	As Designed	As Bid	Completion
HB675 Columbus Basic Renovation	\$650,000.00	\$650,000.00	Total:			
Total:	\$650,000.00	\$650,000.00				

Schedule:	Projected	Revised	Actual
Planning			
Arch/Engr Approved by B/T	05/02/2003		
Bidding Approved B/T	02/06/2004		
Design			
Design Dev Document Approval	01/05/2004		
Construction Document Approval	02/05/2004		
Bidding			
Bid Opening	03/15/2004		
Construction			
Construction Start	06/16/2004		
Completion	10/16/2004		
Report of Award to B/T	12/03/2004		

Veterinary Hospital - Roof Replacement Phase II

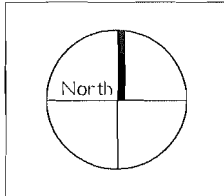
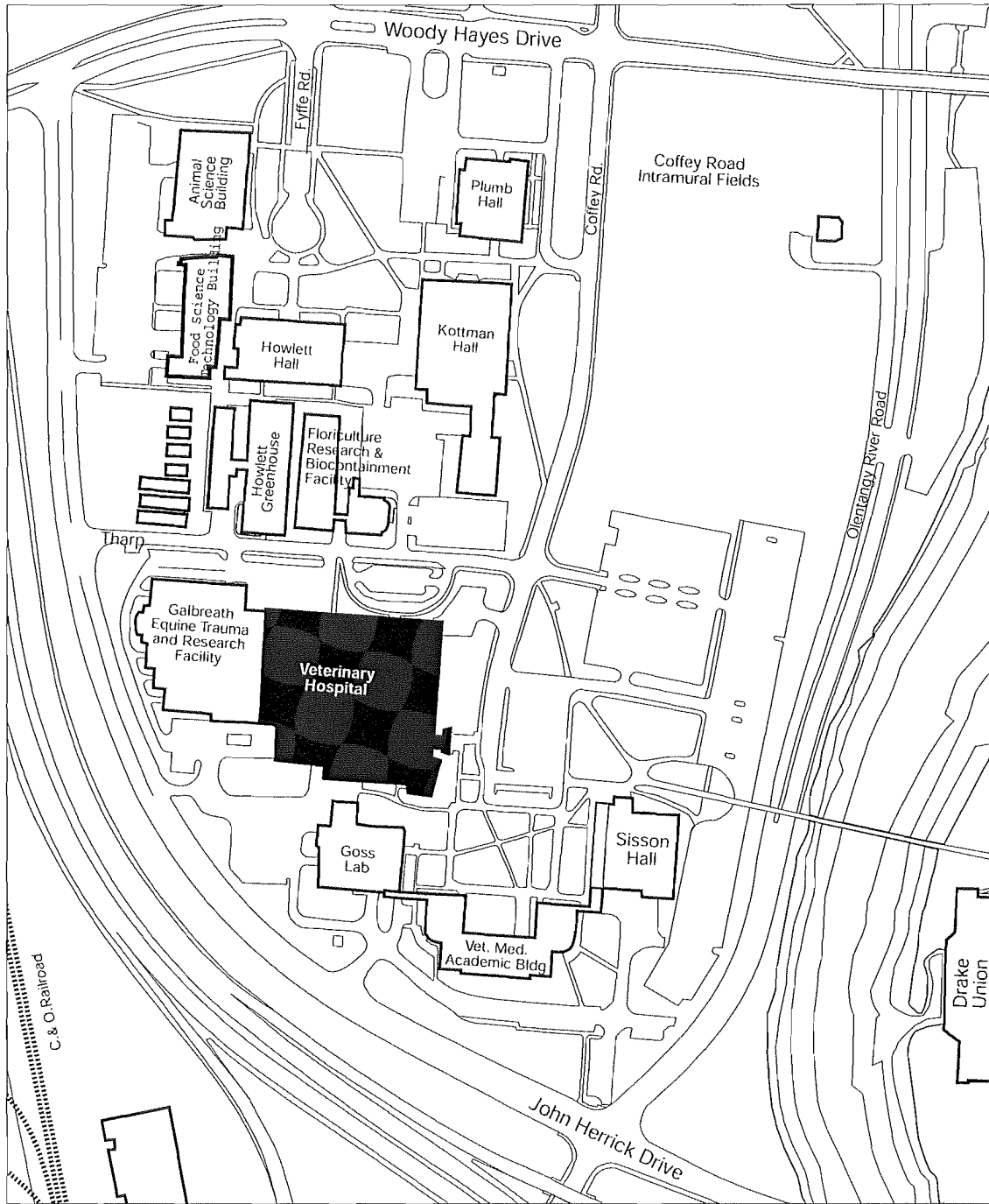



Wiseman Hall - Buildout of 3rd Floor Shell Space
315-2003-960

Requesting Agency(s): CANCER HOSPITAL & RESEARCH INSTITUTE

Location(s): WISEMAN HALL, BRUCE K.

Gross Sq. Ft. 81,693 Age: 1960

Description: The Wiseman Hall Expansion of the Comprehensive Cancer Center project 315-1999-957 adds two levels to the existing Northern Area of Wiseman Hall. The 4th floor expansion was designed for the CCC while the 3rd floor was designed as a shell space for future growth. Now that future growth is needed and funding is being made available for the buildout of the 3rd floor shelled space that is currently under construction.

This buildout should begin construction following the completion of the 315-1999-957 project.

Project Team:

Project Information:

Facility Planner: Is Unassigned

Project Captain: Sara Herridge
(herridge.4@osu.edu)

Project Assistant: Patricia Berger
(berger.58@osu.edu)

Field Coordinator: Is Unassigned

Source of Funds:	Original	Revised	Uses of Funds:	As Designed	As Bid	Completion
Auxiliaries-James Cancer Hospital	\$3,569,940.00	\$3,569,940.00	Total:			
Total:	\$3,569,940.00	\$3,569,940.00				

Wiseman Hall - Buildout of 3rd Floor Shell Space

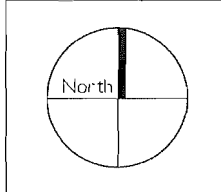
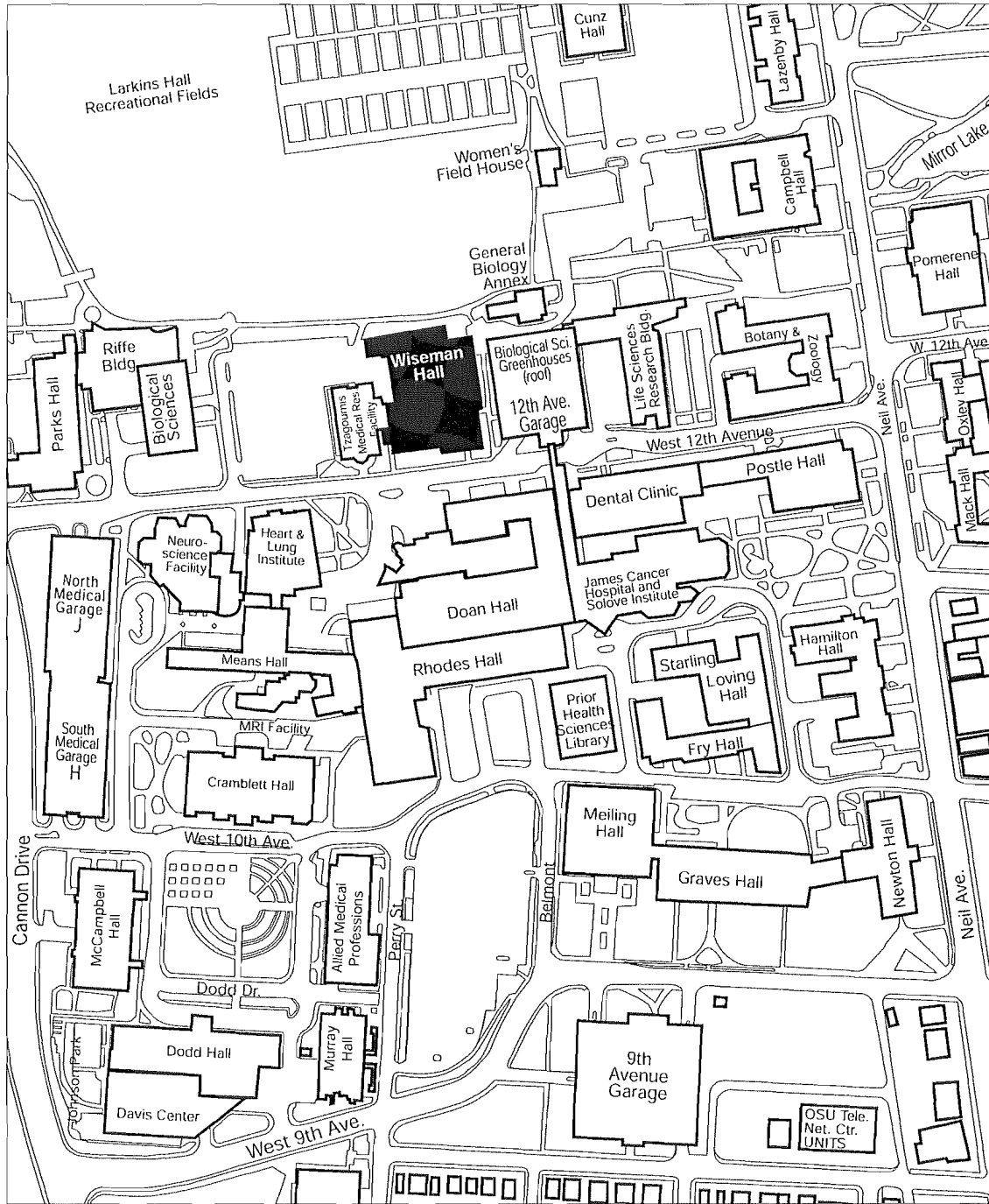



James Cancer Hospital - 3 East and 3 South
315-2003-939

Requesting Agency(s): CANCER HOSPITAL & RESEARCH INSTITUTE

Location(s): COMPREHENSIVE CANCER CENTER, OSU

Gross Sq. Ft. 30,907 Age: 1980

Description: Upgrade patient rooms and renovate nurses station and hallways.

Project Team:

Facility Planner: Is Unassigned

Project Captain: Richard Van Deusen
(van-deusen.2@osu.edu)

Project Assistant: Curt Handschug
(handschug.1@osu.edu)

Field Coordinator: Is Unassigned

Project Information:

Replaced 50700-R034553 & 50700-R034554

Source of Funds:	Original	Revised	Uses of Funds:	As Designed	As Bid	Completion
Auxiliaries-James Cancer Hospital	\$2,134,250.00	\$2,134,250.00	Total:			
Total:	\$2,134,250.00	\$2,134,250.00				

Schedule:

	Projected	Revised	Actual
Planning			
Arch/Engr Approved by B/T	05/02/2003		05/02/2003

James Cancer Hospital - 3 East and 3 South

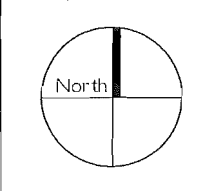
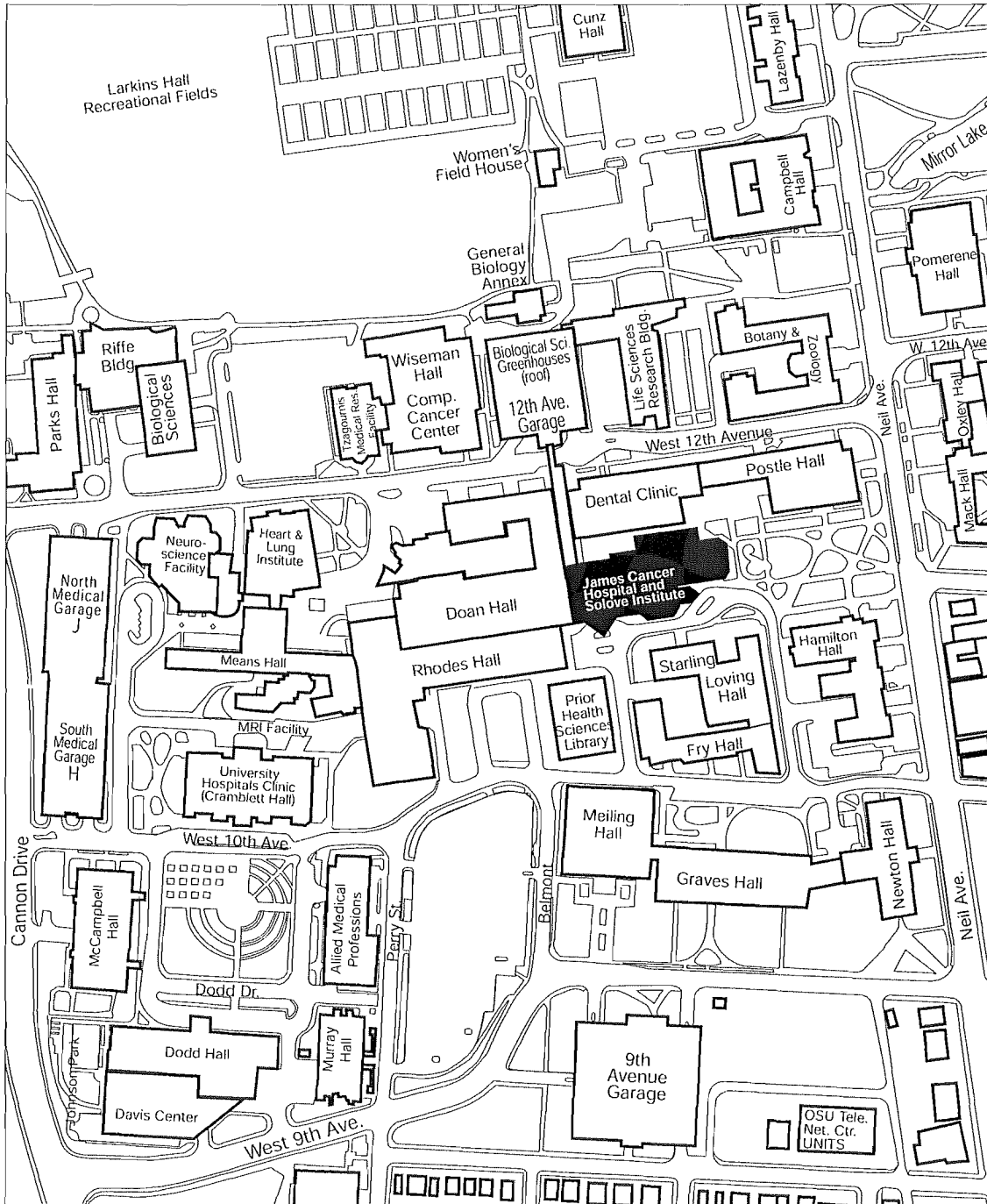



Larkins Natatorium Scoreboard

315-1999-188-4

Requesting Agency(s): ATHLETICS

Location(s): LARKINS HALL, RICHARD C.

Gross Sq. Ft. 353,126 Age: 1931

Description: Install scoreboard in the natatorium area of Larkins Hall to support all athletic and recreational sporting events.

Scoreboard will have full matrix graphics and animation and advertising capabilities.

Project Team:

Project Information:

Facility Planner: Is Unassigned

Project Captain: Dave Chapman
(chapman.123@osu.edu)

Project Assistant: Faye Bodyke
(bodyke.3@osu.edu)

Field Coordinator: Is Unassigned

Source of Funds:	Original	Revised	Uses of Funds:	As Designed	As Bid	Completion
Future Univ. Bond Issues	\$529,560.00	\$529,560.00				
Total:	\$529,560.00	\$529,560.00	Total:			

Schedule:	Projected	Revised	Actual
Planning			
Bidding Approved B/T (529,560)	05/30/2003		
Construction			
Award of Contracts	06/13/2003		
Construction Start	07/02/2004		
Completion	09/01/2004		

Larkins Natatorium Scoreboard

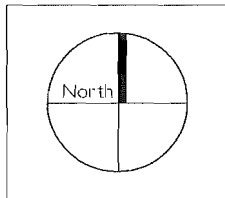
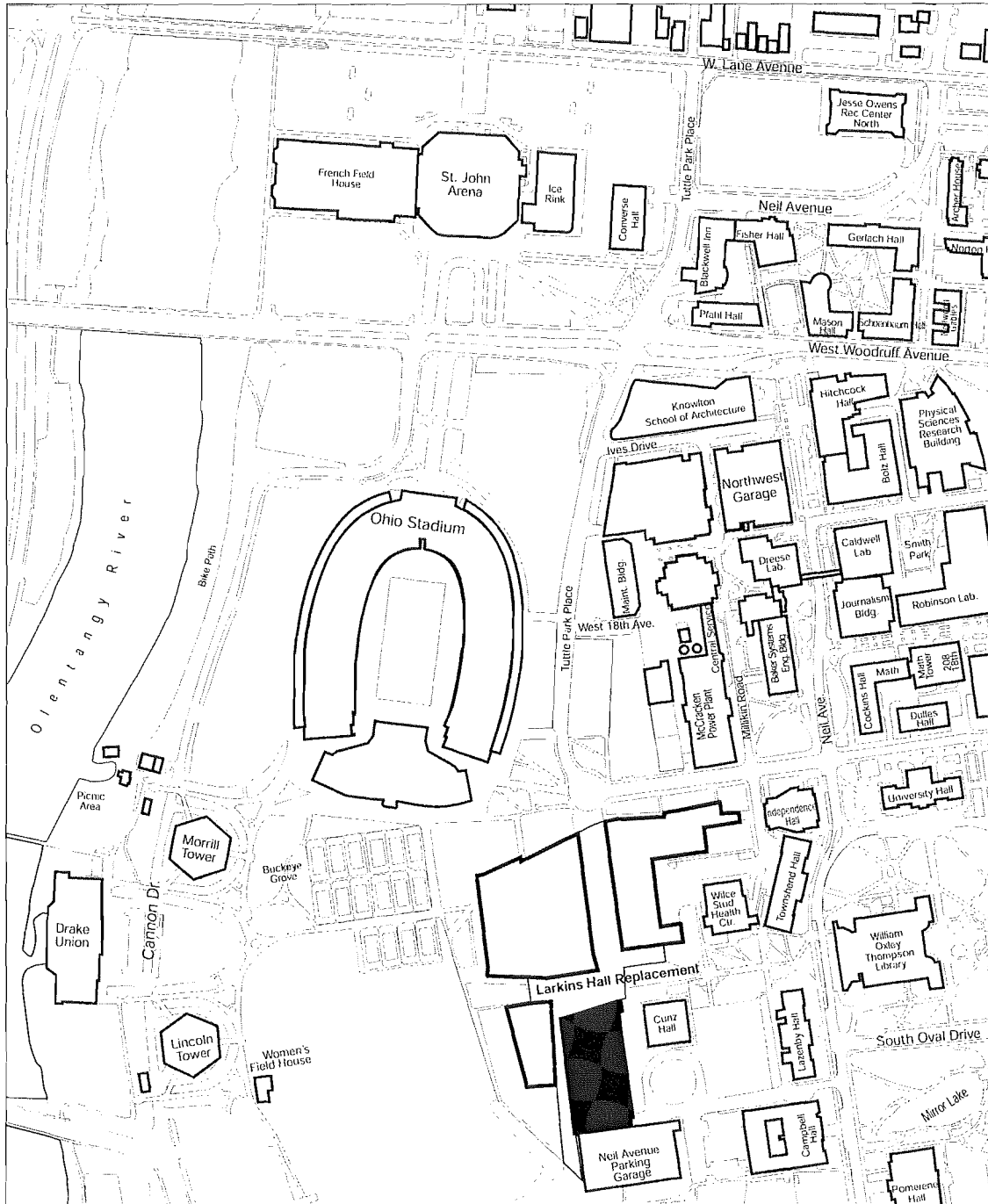



Neil Avenue Garage

315-1999-188-1

Requesting Agency(s): TRANSPORTATION & PARKING SERVICES

Location(s): Site - See Comments.

Gross Sq. Ft.0 Age:

Description: Construct an appromiximately 650 space garage to be built in association with the Larkins Hall project. .

Project Team:

Facility Planner: Cheryl Christie
(christie.2@osu.edu)
Project Captain: Dave Chapman
(chapman.123@osu.edu)
Project Assistant: Faye Bodyke
(bodyke.3@osu.edu)
Field Coordinator: Is Unassigned

Project Information:

The project site is located East of, and directly adjacent to the current Larkins soccer field and will be attached to the southern most portion on the new Larkins Natatorium. The duct bank will be extended and funded by project 5062-PF990626 Project increased to support two additional floors with 240 spaces and funded by excess funds from the Hospitals Garage Project

Source of Funds:	Original	Revised	Uses of Funds:	As Designed	As Bid	Completion
Future Univ. Bond Issues	\$0.00	\$14,838,471.00				
Auxiliaries-Trans. & Parking	\$11,809,364.00	\$0.00	Total:			
Total:	\$11,809,364.00	\$14,838,471.00				

Schedule:	Projected	Revised	Actual
Planning			
Arch/Engr Approved by B/T (\$11,809,364 Project)	06/29/2001		06/29/2001
Constr Mgr Approved by B/T (\$11,809,364 Project)	06/29/2001		06/29/2001
Bidding Approved B/T (\$11,809,364 Project)	06/29/2001	07/01/2002	06/29/2001
Design			
Arch/Engr Contract	07/02/2001	07/31/2001	07/23/2001
Schematic Design Approval	07/25/2001	08/19/2002	08/19/2002
Design Dev Document Approval	09/03/2001	08/19/2002	08/19/2002
Construction Document Approval	03/01/2002	01/31/2003	01/31/2003
Construction Document Approval (Additional 2 Floors)	05/19/2003		
Bidding			
Bid Opening	06/30/2002	03/06/2003	03/06/2003
Bid Opening (Additional 2 Floors)	07/01/2003		
Construction			
Award of Contracts	08/01/2002	05/05/2003	05/05/2003
Construction Start	08/15/2002	05/12/2003	05/08/2003
Award of Contracts (Additional 2 Floors)	09/01/2003		
Completion	02/16/2004	07/06/2004	
Construction Start (Additional 2 Floors)	08/07/2004		
Completion (Additional 2 Floors)	08/07/2005		

Neil Avenue Garage

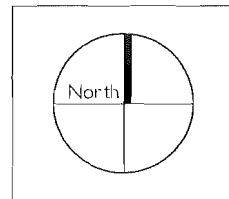
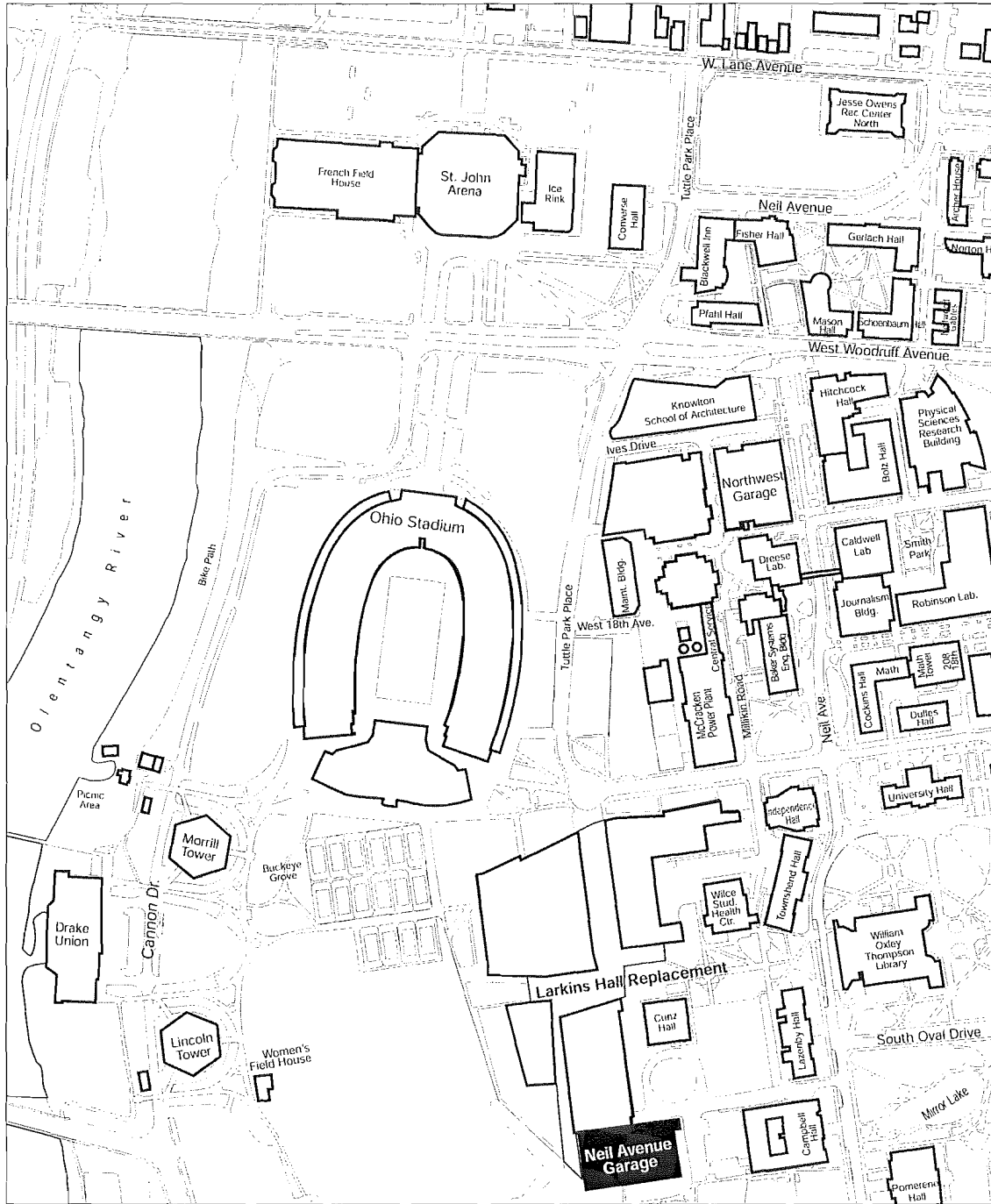



OARDC - Piketon Training and Development Center

315-2002-901

Requesting Agency(s): OHIO AGRIC RESEARCH & DEVELOPMENT CTR

Location(s): Site - See Comments.

Gross Sq. Ft.0 Age:

Description: Construct a new Multi-Purpose Building at Piketon for use by OARDC. New building will provide space for technology training and a business incubator center.

Project Team:

Facility Planner: Is Unassigned

Project Captain: Steve Middleton
(middleton.52@osu.edu)

Project Assistant: Steve Deedrick
(deedrick.4@osu.edu)

Field Coordinator: Is Unassigned

Project Information:

Site to be on the OARDC Piketon facilities.

Source of Funds:	Original	Revised	Uses of Funds:	As Designed	As Bid	Completion
Future Capital	\$900,000.00	\$0.00				
Appropriations			Total:			
Grant-Economic	\$1,920,000.00	\$1,920,000.00				
Development Admin						
Grant-Appalachian Reg.	\$270,000.00	\$270,000.00				
Commission						
HB675 Line Item	\$0.00	\$900,000.00				
Total:	\$3,090,000.00	\$3,090,000.00				

Schedule:	Projected	Revised	Actual
Planning			
Arch/Engr Approved by B/T (\$3,090,000 Project)	02/01/2002		02/01/2002
Bidding Approved B/T	02/07/2003	05/30/2003	
Design			
Arch/Engr Contract	07/30/2002	08/16/2002	08/15/2002
Schematic Design Approval	11/15/2002	12/20/2002	12/17/2002
Design Dev Document Approval	11/15/2002	12/20/2002	12/17/2002
Construction Document Approval	03/19/2003	05/28/2003	
Bidding			
Bid Opening	04/23/2003	07/02/2003	
Construction			
Award of Contracts	06/18/2003	08/27/2003	
Construction Start	07/07/2003	09/15/2003	
Report of Award to B/T	09/01/2003	11/10/2003	
Completion	06/07/2004	08/16/2004	

OARDC - Piketon Training and Development Center

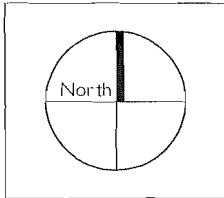



Requesting Agency(s): OSUE AGRIC & NATURAL RESOURCES

Location(s): Site - See Comments.

Gross Sq. Ft.0 Age:

Description: This project consists of the demolition of Dakan Hall and the planning, programming, design, FF&E, site planning and construction administration of the new Ohio 4-H Center. The new structure will include space for the OSU 4-H Youth Development staff, the OSU Extension programs, and those programs from the College of Food, Agricultural, and Environmental Sciences who will interact with 4-H. Outdoor program space, outdoor amenities, and parking is also included.

Project Team:

Facility Planner: Cheryl Christie (christie.2@osu.edu)
Project Captain: Marjory Spangler (spangler.40@osu.edu)
Project Assistant: Steve Deedrick (deedrick.4@osu.edu)
Field Coordinator: Is Unassigned

Project Information:

A study was made to determine whether renovating a current building or building a new facility would be the most feasible.
Building to be constructed on the site north of the existing Dakan Hall.
Project increased to \$10 million to support increase in building size the 4-H program needs.

Table with 7 columns: Source of Funds, Original, Revised, Uses of Funds, As Designed, As Bid, Completion. Rows include Development-Food, Agr & Env Sciences and a Total row.



Schedule:	Projected	Revised	Actual
Planning			
MOU Approved by the University	01/08/2002		01/08/2002
Arch/Engr Approved by B/T (\$9,110,627 Project)	03/01/2002		03/01/2002
Bidding Approved B/T (\$9,110,627 Project)	03/01/2002		03/01/2002
Design			
Arch/Engr Contract	07/01/2002	12/31/2002	01/08/2003
Schematic Design Approval	09/30/2002	08/15/2003	
Design Dev Document Approval	11/25/2002	09/05/2003	
Construction Document Approval	03/17/2003	12/26/2003	
Bidding			
Bid Opening	05/06/2003	02/13/2004	
Construction			
Award of Contracts	06/16/2003	03/26/2004	
Construction Start	06/16/2003	03/26/2004	
Report of Award to B/T	08/01/2003	05/12/2004	
Completion	07/01/2004	04/11/2005	
FF&E			
FF&E Program Review (Reviewing PoR w/Assoc)	02/19/2003	09/19/2003	
FF&E Final Quotes From Contracts	02/23/2004	08/16/2004	
FF&E Purchasing	02/17/2003	09/16/2004	
FF&E Purchase Order Issurance	03/03/2004	10/01/2004	
FF&E Installation	08/25/2003	03/25/2005	
FF&E Purch List, Close Out Inspection	09/09/2003	04/08/2005	

Ohio 4-H Center

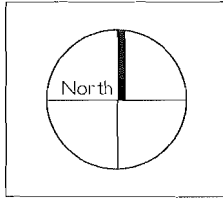
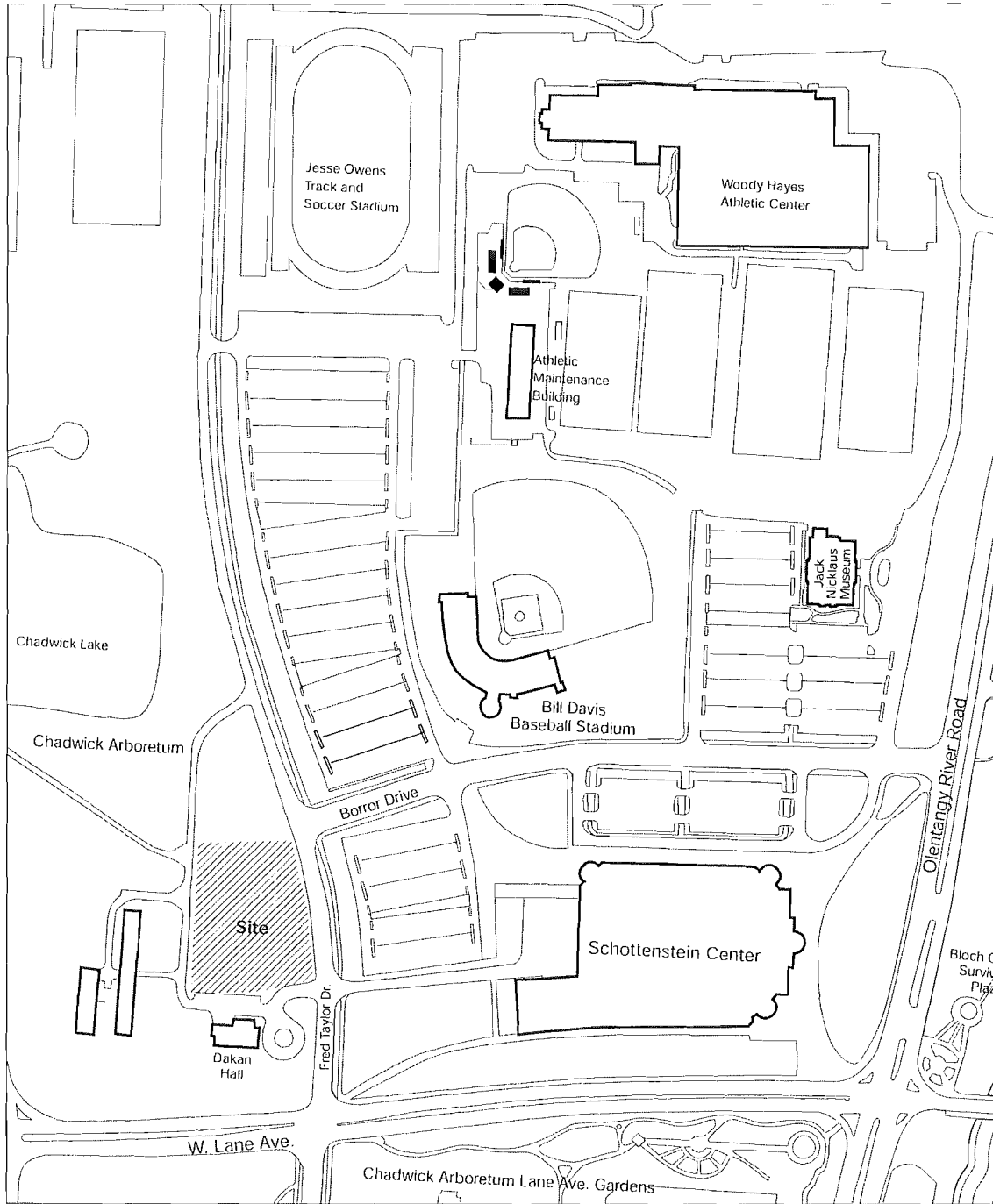



Tzagournis Medical Research Facility - Room 190

315-2003-901

Requesting Agency(s): MEDICINE AND PUBLIC HEALTH ADMIN

Location(s): TZAGOURNIS MEDICAL RESEARCH FACILITY

Gross Sq. Ft.78,705 Age: 1994

Description: Renovate Room 190 of TMRF to house an animal MRI.
OFP #02-157

Project Team:

Facility Planner: Is Unassigned

Project Captain: Richard Van Deusen
(van-deusen.2@osu.edu)

Project Assistant: Andrea Thimmes
(thimmes.5@osu.edu)

Field Coordinator: Is Unassigned

Project Information:

Formerly known as 50700-R025199

Source of Funds:	Original	Revised	Uses of Funds:	As Designed	As Bid	Completion
Development-Medicine	\$357,490.00	\$357,490.00				
Total:	\$357,490.00	\$357,490.00	Total:			

Schedule:	Projected	Revised	Actual
Planning			
6540 Received by OFP			11/13/2002
Request for Estimate Received - OA			11/13/2002
Request for Estimate Returned			12/19/2002

Tzagouris Medical Research Facility - Room 190

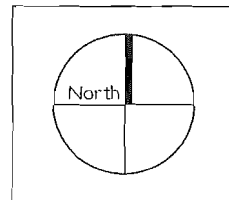
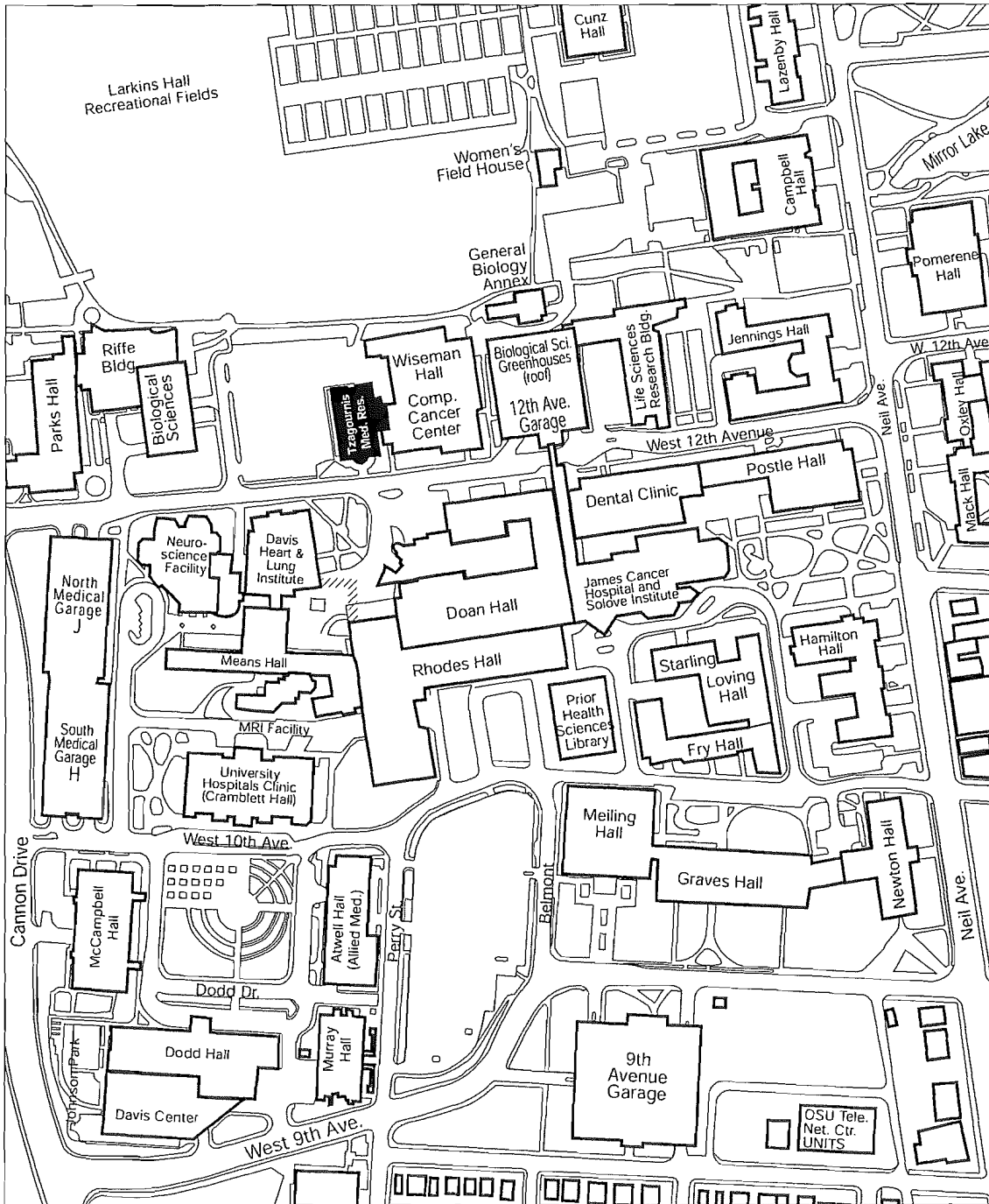



Veterinary Hospital - Roof Replacement Phase II

315-2003-933

Requesting Agency(s): PHYSICAL FACILITIES

Location(s): VETERINARY HOSPITAL

Gross Sq. Ft.222,496 Age: 1973

Description: Removal / replacement of the remaining Vet Hospital roof areas. The existing built-up roof needs to be removed and replaced with a new coal tar 4-ply roof system. (Reuse existing metal flashings and counterflashings.)

Project Team:

Facility Planner: Is Unassigned
 Project Captain: Brett Garrett
 Project Assistant: Is Unassigned
 Field Coordinator: Is Unassigned

Project Information:

Source of Funds:	Original	Revised	Uses of Funds:	As Designed	As Bid	Completion
HB675 Columbus Basic Renovation	\$650,000.00	\$650,000.00	Total:			
Total:	\$650,000.00	\$650,000.00				

Schedule:	Projected	Revised	Actual
Planning			
Arch/Engr Approved by B/T	05/02/2003		
Bidding Approved B/T	02/06/2004		
Design			
Design Dev Document Approval	01/05/2004		
Construction Document Approval	02/05/2004		
Bidding			
Bid Opening	03/15/2004		
Construction			
Construction Start	06/16/2004		
Completion	10/16/2004		
Report of Award to B/T	12/03/2004		

Veterinary Hospital - Roof Replacement Phase II

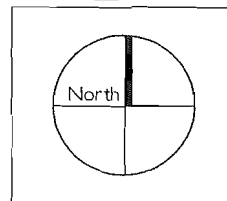
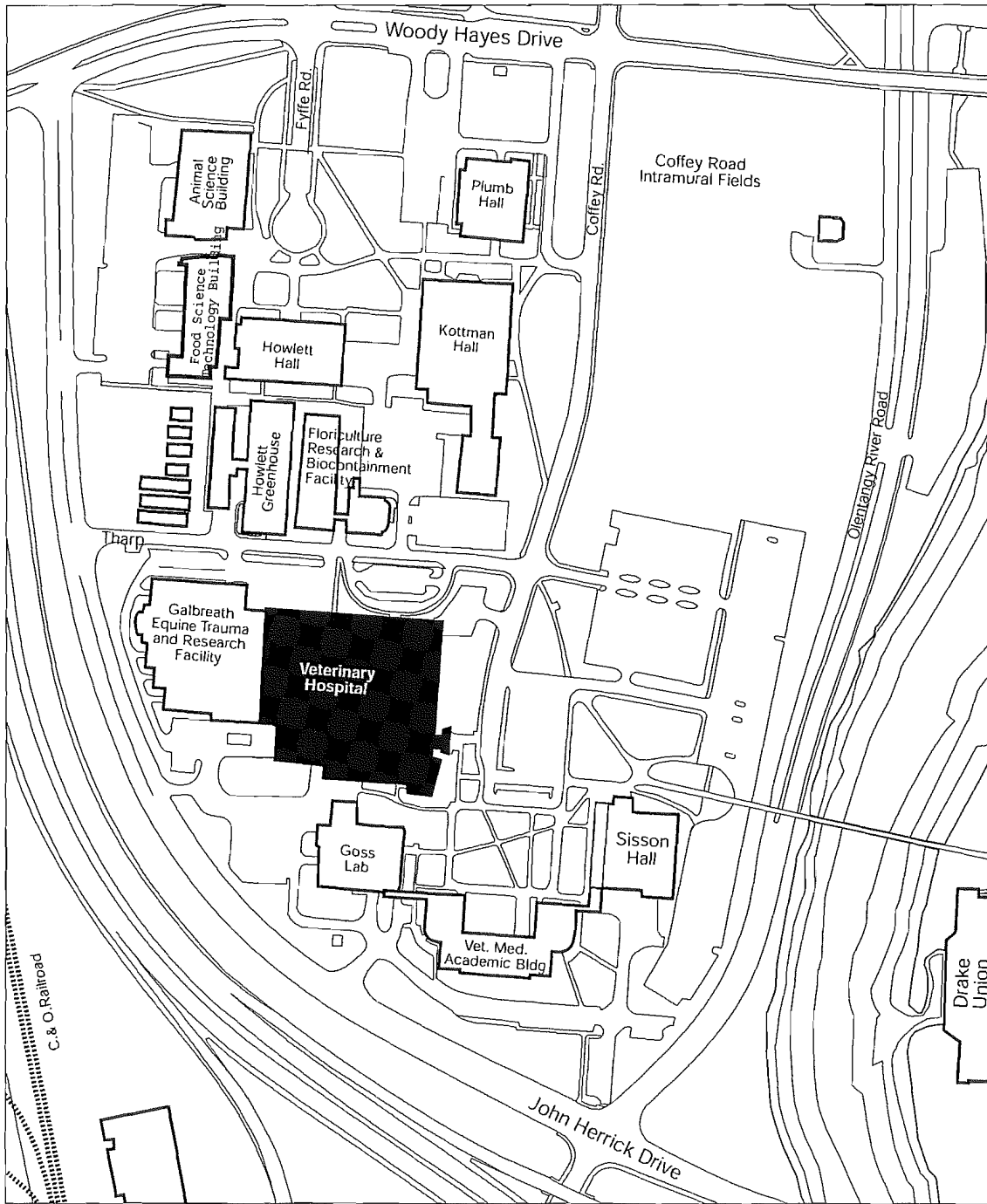



Wiseman Hall - Buildout of 3rd Floor Shell Space

315-2003-960

Requesting Agency(s): CANCER HOSPITAL & RESEARCH INSTITUTE

Location(s): WISEMAN HALL, BRUCE K.

Gross Sq. Ft.81,693 Age: 1960

Description: The Wiseman Hall Expansion of the Comprehensive Cancer Center project 315-1999-957 adds two levels to the existing Northern Area of Wiseman Hall. The 4th floor expansion was designed for the CCC while the 3rd floor was designed as a shell space for future growth. Now that future growth is needed and funding is being made available for the buildout of the 3rd floor shelled space that is currently under construction.

This buildout should begin construction following the completion of the 315-1999-957 project.

Project Team:

Project Information:

Facility Planner: Is Unassigned

Project Captain: Sara Herridge
(herridge.4@osu.edu)

Project Assistant: Patricia Berger
(berger.58@osu.edu)

Field Coordinator: Is Unassigned

Source of Funds:	Original	Revised	Uses of Funds:	As Designed	As Bid	Completion
Auxiliaries-James Cancer Hospital	\$3,569,940.00	\$3,569,940.00	Total:			
Total:	\$3,569,940.00	\$3,569,940.00				

Wiseman Hall - Buildout of 3rd Floor Shell Space

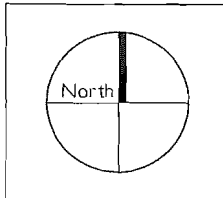
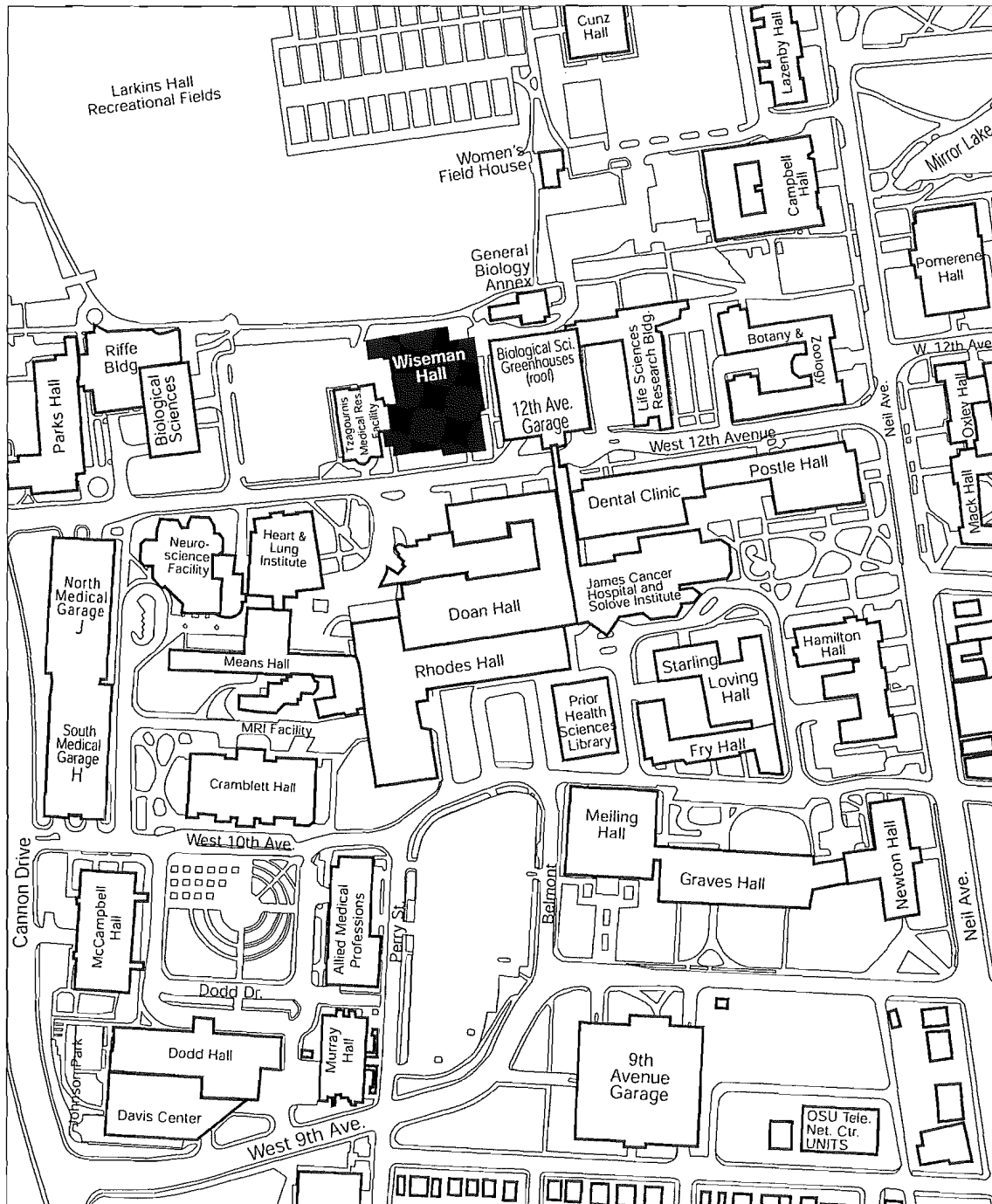



James Cancer Hospital - 3 East and 3 South

315-2003-939

Requesting Agency(s): CANCER HOSPITAL & RESEARCH INSTITUTE

Location(s): COMPREHENSIVE CANCER CENTER, OSU

Gross Sq. Ft.30,907 Age: 1980

Description: Upgrade patient rooms and renovate nurses station and hallways.

Project Team:

Facility Planner: Is Unassigned

Project Captain: Richard Van Deusen
(van-deusen.2@osu.edu)

Project Assistant: Curt Handschug
(handschug.1@osu.edu)

Field Coordinator: Is Unassigned

Project Information:

Replaced 50700-R034553 & 50700-R034554

Source of Funds:	Original	Revised	Uses of Funds:	As Designed	As Bid	Completion
Auxiliaries-James Cancer Hospital	\$2,134,250.00	\$2,134,250.00				
Total:	\$2,134,250.00	\$2,134,250.00	Total:			

Schedule:	Projected	Revised	Actual
Planning Arch/Engr Approved by B/T	05/02/2003		05/02/2003

James Cancer Hospital - 3 East and 3 South

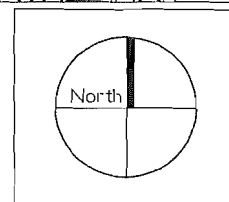
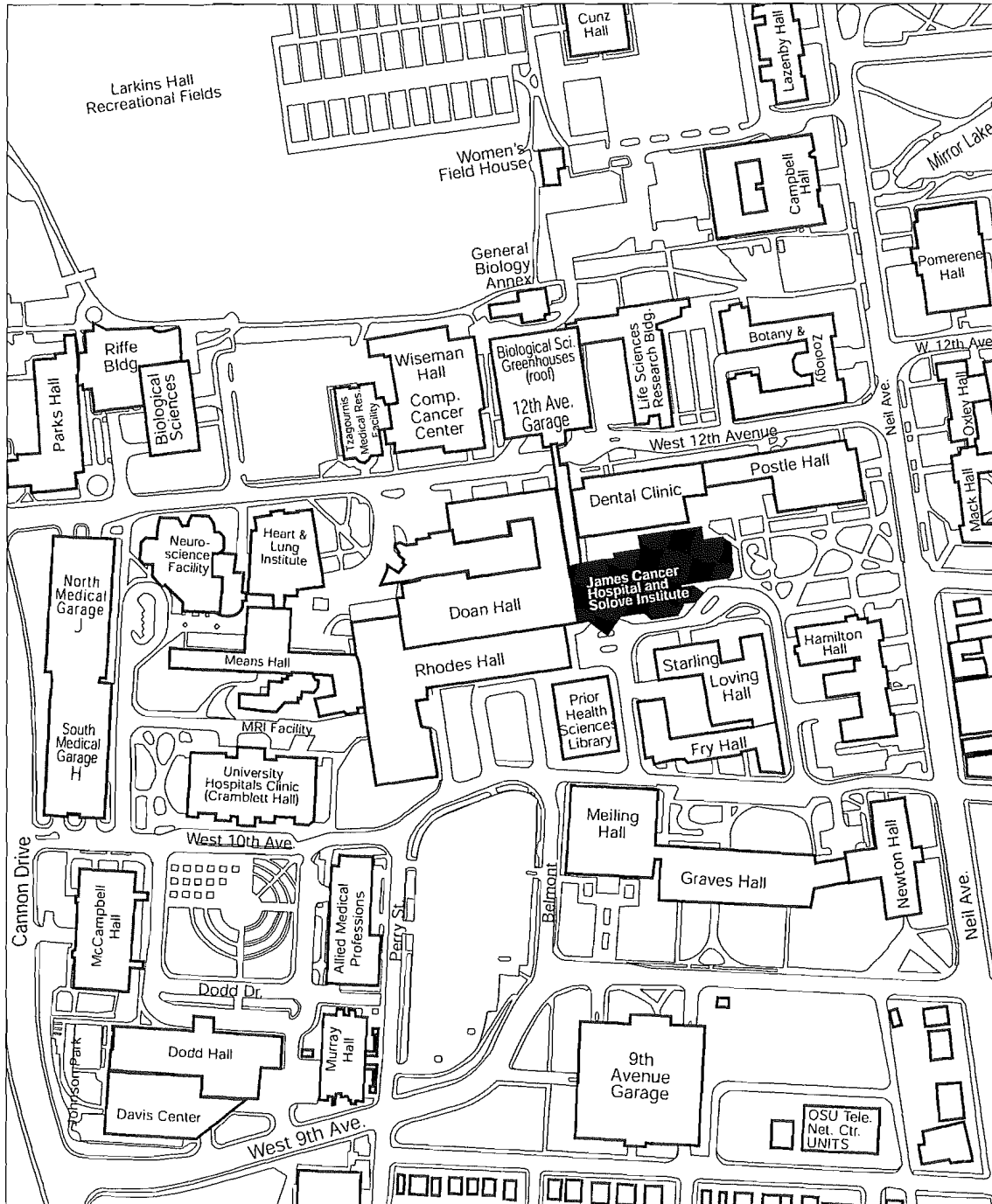



Larkins Natatorium Scoreboard

315-1999-188-4

Requesting Agency(s): ATHLETICS

Location(s): LARKINS HALL, RICHARD C.

Gross Sq. Ft.353,126 Age: 1931

Description: Install scoreboard in the natatorium area of Larkins Hall to support all athletic and recreational sporting events.

Scoreboard will have full matrix graphics and animation and advertising capabilities.

Project Team:

Project Information:

Facility Planner: Is Unassigned

Project Captain: Dave Chapman
(chapman.123@osu.edu)

Project Assistant: Faye Bodyke
(bodyke.3@osu.edu)

Field Coordinator: Is Unassigned

Source of Funds:	Original	Revised	Uses of Funds:	As Designed	As Bid	Completion
Future Univ. Bond Issues	\$529,560.00	\$529,560.00				
Total:	\$529,560.00	\$529,560.00	Total:			

Schedule:	Projected	Revised	Actual
Planning			
Bidding Approved B/T (529,560)	05/30/2003		
Construction			
Award of Contracts	06/13/2003		
Construction Start	07/02/2004		
Completion	09/01/2004		

Larkins Natatorium Scoreboard

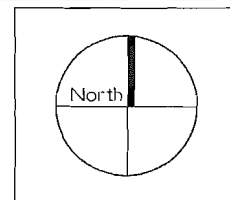
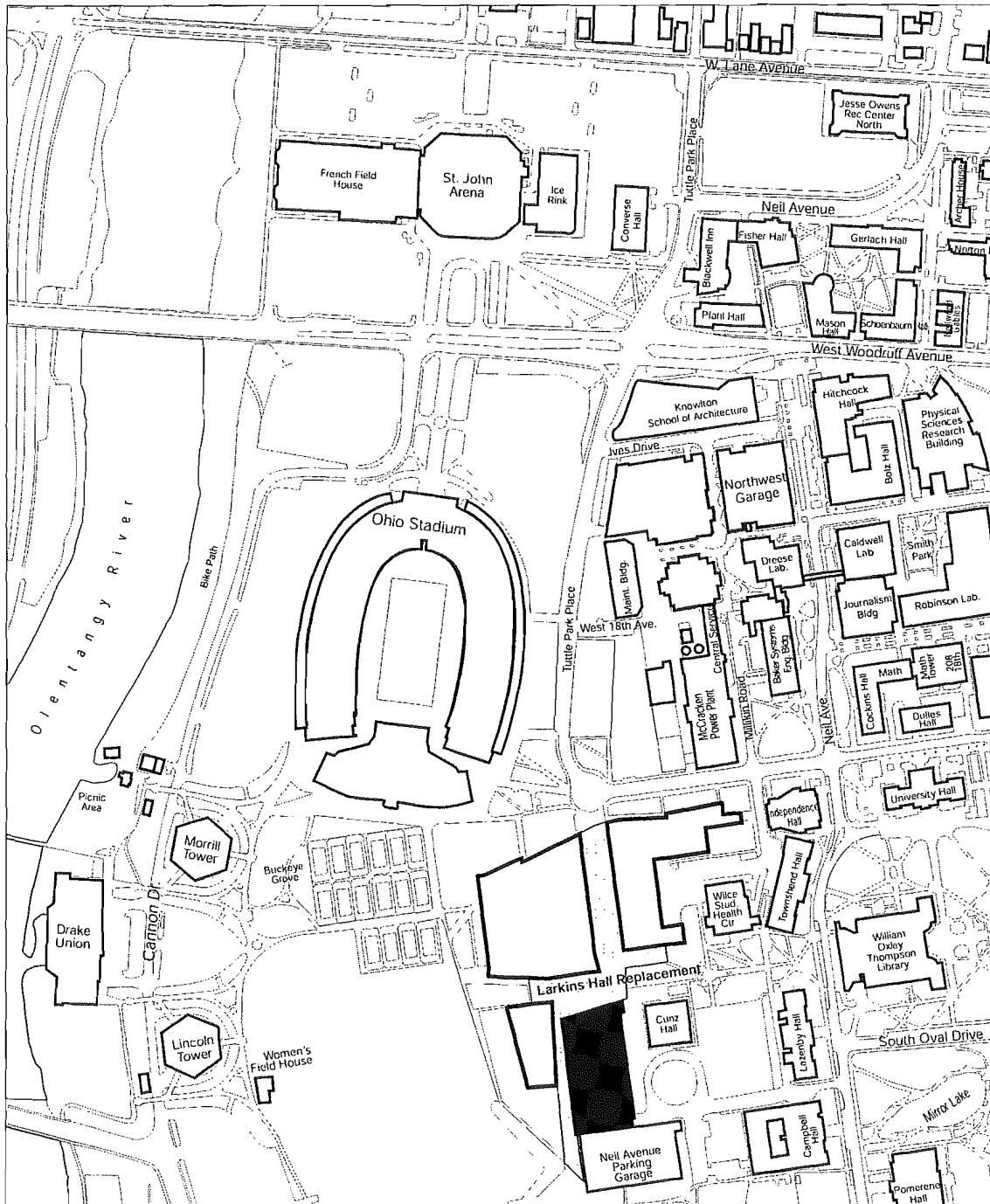

Office of Business and Finance
Office of Facilities Planning and Development

May 20, 2003



Neil Avenue Garage

315-1999-188-1

Requesting Agency(s): TRANSPORTATION & PARKING SERVICES

Location(s): Site - See Comments.

Gross Sq. Ft.0 Age:

Description: Construct an approximately 650 space garage to be built in association with the Larkins Hall project. .

Project Team:

Facility Planner: Cheryl Christie
(christie.2@osu.edu)

Project Captain: Dave Chapman
(chapman.123@osu.edu)

Project Assistant: Faye Bodyke
(bodyke.3@osu.edu)

Field Coordinator: Is Unassigned

Project Information:

The project site is located East of, and directly adjacent to the current Larkins soccer field and will be attached to the southern most portion on the new Larkins Natatorium.

The duct bank will be extended and funded by project 5062-PF990626

Project increased to support two additional floors with 240 spaces and funded by excess funds from the Hospitals Garage Project

Source of Funds:	Original	Revised	Uses of Funds:	As Designed	As Bid	Completion
Future Univ. Bond Issues	\$0.00	\$14,838,471.00				
Auxiliaries-Trans. & Parking	\$11,809,364.00	\$0.00	Total:			
Total:	\$11,809,364.00	\$14,838,471.00				

Schedule:	Projected	Revised	Actual
Planning			
Arch/Engr Approved by B/T (\$11,809,364 Project)	06/29/2001		06/29/2001
Constr Mgr Approved by B/T (\$11,809,364 Project)	06/29/2001		06/29/2001
Bidding Approved B/T (\$11,809,364 Project)	06/29/2001	07/01/2002	06/29/2001
Design			
Arch/Engr Contract	07/02/2001	07/31/2001	07/23/2001
Schematic Design Approval	07/25/2001	08/19/2002	08/19/2002
Design Dev Document Approval	09/03/2001	08/19/2002	08/19/2002
Construction Document Approval	03/01/2002	01/31/2003	01/31/2003
Construction Document Approval (Additional 2 Floors)	05/19/2003		
Bidding			
Bid Opening	06/30/2002	03/06/2003	03/06/2003
Bid Opening (Additional 2 Floors)	07/01/2003		
Construction			
Award of Contracts	08/01/2002	05/05/2003	05/05/2003
Construction Start	08/15/2002	05/12/2003	05/08/2003
Award of Contracts (Additional 2 Floors)	09/01/2003		
Completion	02/16/2004	07/06/2004	
Construction Start (Additional 2 Floors)	08/07/2004		
Completion (Additional 2 Floors)	08/07/2005		

Neil Avenue Garage

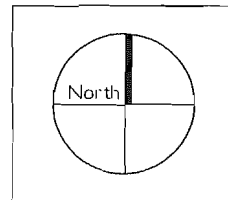
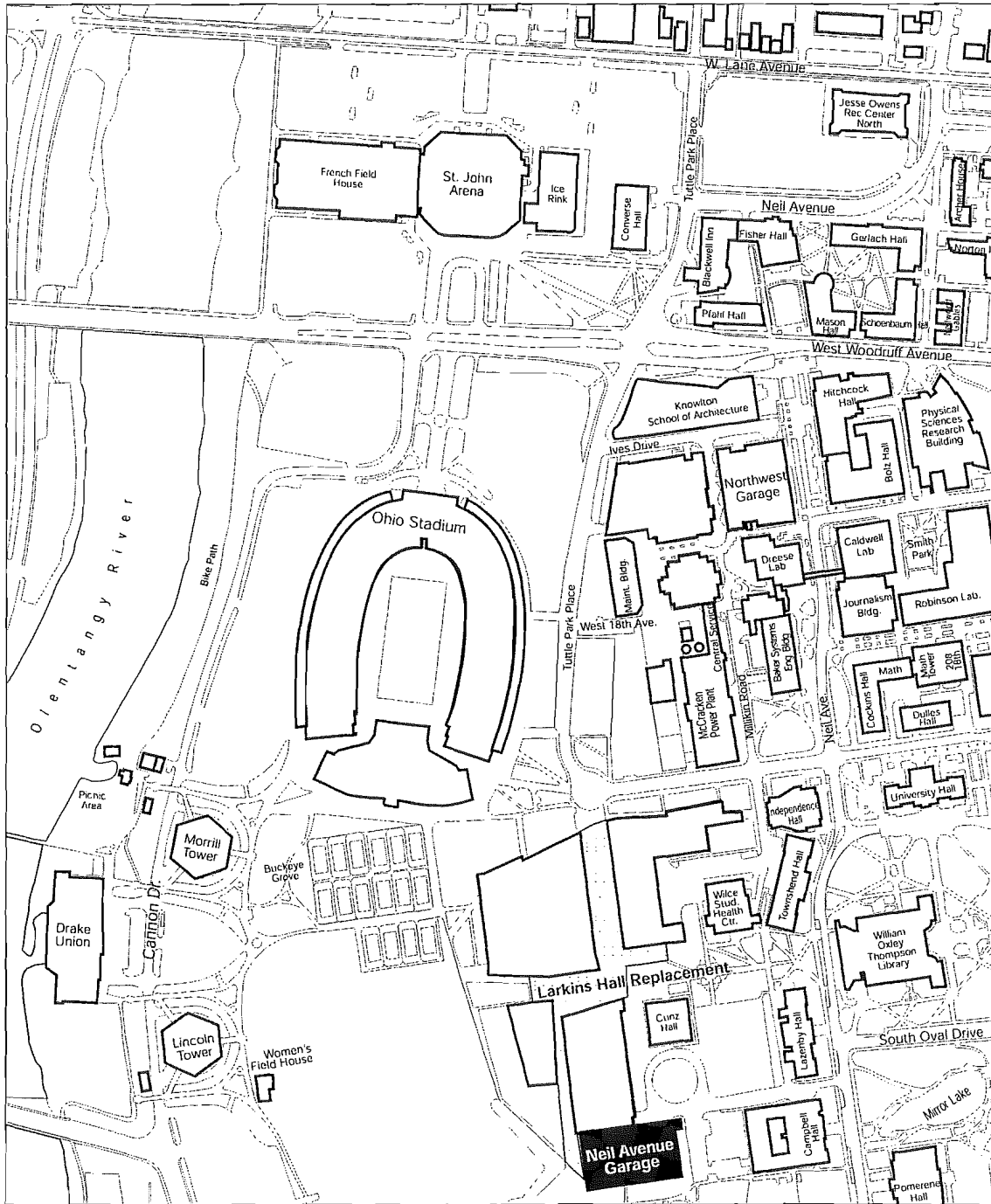



OARDC - Piketon Training and Development Center

315-2002-901

Requesting Agency(s): OHIO AGRIC RESEARCH & DEVELOPMENT CTR

Location(s): Site - See Comments.

Gross Sq. Ft.0 Age:

Description: Construct a new Multi-Purpose Building at Piketon for use by OARDC. New building will provide space for technology training and a business incubator center.

Project Team:

Facility Planner: Is Unassigned

Project Captain: Steve Middleton
(middleton.52@osu.edu)

Project Assistant: Steve Deedrick
(deedrick.4@osu.edu)

Field Coordinator: Is Unassigned

Project Information:

Site to be on the OARDC Piketon facilities.

Source of Funds:	Original	Revised	Uses of Funds:	As Designed	As Bid	Completion
Future Capital	\$900,000.00	\$0.00				
Appropriations			Total:			
Grant-Economic	\$1,920,000.00	\$1,920,000.00				
Development Admin						
Grant-Appalachian Reg.	\$270,000.00	\$270,000.00				
Commission						
HB675 Line Item	\$0.00	\$900,000.00				
Total:	\$3,090,000.00	\$3,090,000.00				

Schedule:	Projected	Revised	Actual
Planning			
Arch/Engr Approved by B/T (\$3,090,000 Project)	02/01/2002		02/01/2002
Bidding Approved B/T	02/07/2003	05/30/2003	
Design			
Arch/Engr Contract	07/30/2002	08/16/2002	08/15/2002
Schematic Design Approval	11/15/2002	12/20/2002	12/17/2002
Design Dev Document Approval	11/15/2002	12/20/2002	12/17/2002
Construction Document Approval	03/19/2003	05/28/2003	
Bidding			
Bid Opening	04/23/2003	07/02/2003	
Construction			
Award of Contracts	06/18/2003	08/27/2003	
Construction Start	07/07/2003	09/15/2003	
Report of Award to B/T	09/01/2003	11/10/2003	
Completion	06/07/2004	08/16/2004	

OARDC - Piketon Training and Development Center

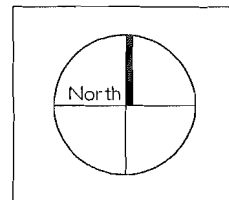
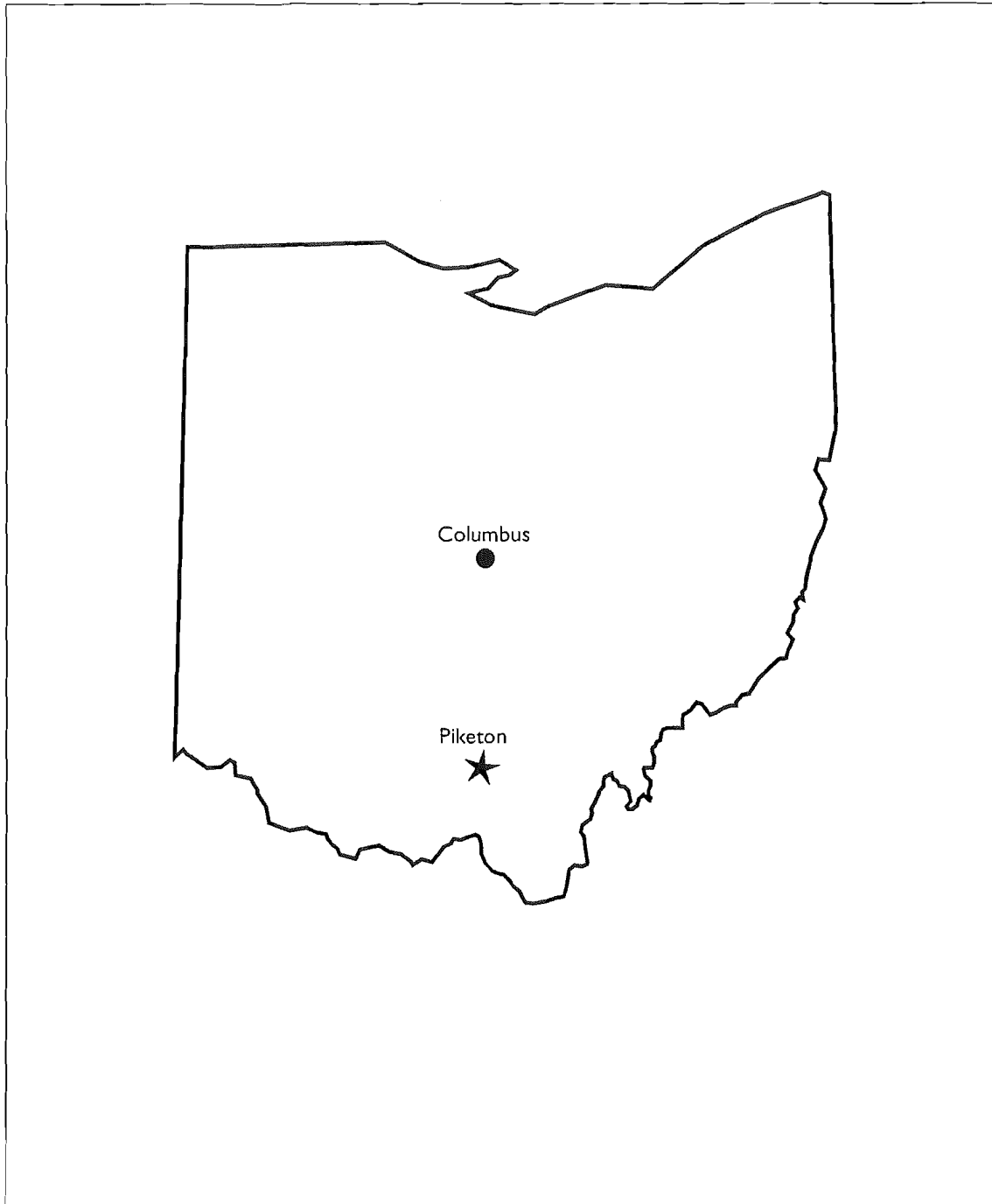



Requesting Agency(s): OSUE AGRIC & NATURAL RESOURCES

Location(s): Site - See Comments.

Gross Sq. Ft.0 Age:

Description: This project consists of the demolition of Dakan Hall and the planning, programming, design, FF&E, site planning and construction administration of the new Ohio 4-H Center. The new structure will include space for the OSU 4-H Youth Development staff, the OSU Extension programs, and those programs from the College of Food, Agricultural, and Environmental Sciences who will interact with 4-H. Outdoor program space, outdoor amenities, and parking is also included.

Project Team:

Facility Planner: Cheryl Christie
(christie.2@osu.edu)
Project Captain: Marjory Spangler
(spangler.40@osu.edu)
Project Assistant: Steve Deedrick
(deedrick.4@osu.edu)
Field Coordinator: Is Unassigned

Project Information:

A study was made to determine whether renovating a current building or building a new facility would be the most feasible.

Building to be constructed on the site north of the existing Dakan Hall.
Project increased to \$10 million to support increase in building size the 4-H program needs.

Source of Funds:	Original	Revised	Uses of Funds:	As Designed	As Bid	Completion
Development-Food,Agr & Env Sciences	\$9,110,627.00	\$10,000,000.00				
Total:	\$9,110,627.00	\$10,000,000.00	Total:			



Ohio 4-H Center
315-2000-911

Schedule:	Projected	Revised	Actual
Planning			
MOU Approved by the University	01/08/2002		01/08/2002
Arch/Engr Approved by B/T (\$9,110,627 Project)	03/01/2002		03/01/2002
Bidding Approved B/T (\$9,110,627 Project)	03/01/2002		03/01/2002
Design			
Arch/Engr Contract	07/01/2002	12/31/2002	01/08/2003
Schematic Design Approval	09/30/2002	08/15/2003	
Design Dev Document Approval	11/25/2002	09/05/2003	
Construction Document Approval	03/17/2003	12/26/2003	
Bidding			
Bid Opening	05/06/2003	02/13/2004	
Construction			
Award of Contracts	06/16/2003	03/26/2004	
Construction Start	06/16/2003	03/26/2004	
Report of Award to B/T	08/01/2003	05/12/2004	
Completion	07/01/2004	04/11/2005	
FF&E			
FF&E Program Review (Reviewing PoR w/ Assoc)	02/19/2003	09/19/2003	
FF&E Final Quotes From Contracts	02/23/2004	08/16/2004	
FF&E Purchasing	02/17/2003	09/16/2004	
FF&E Purchase Order Issurance	03/03/2004	10/01/2004	
FF&E Installation	08/25/2003	03/25/2005	
FF&E Purch List, Close Out Inspection	09/09/2003	04/08/2005	

Ohio 4-H Center

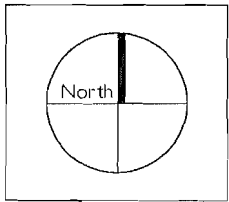
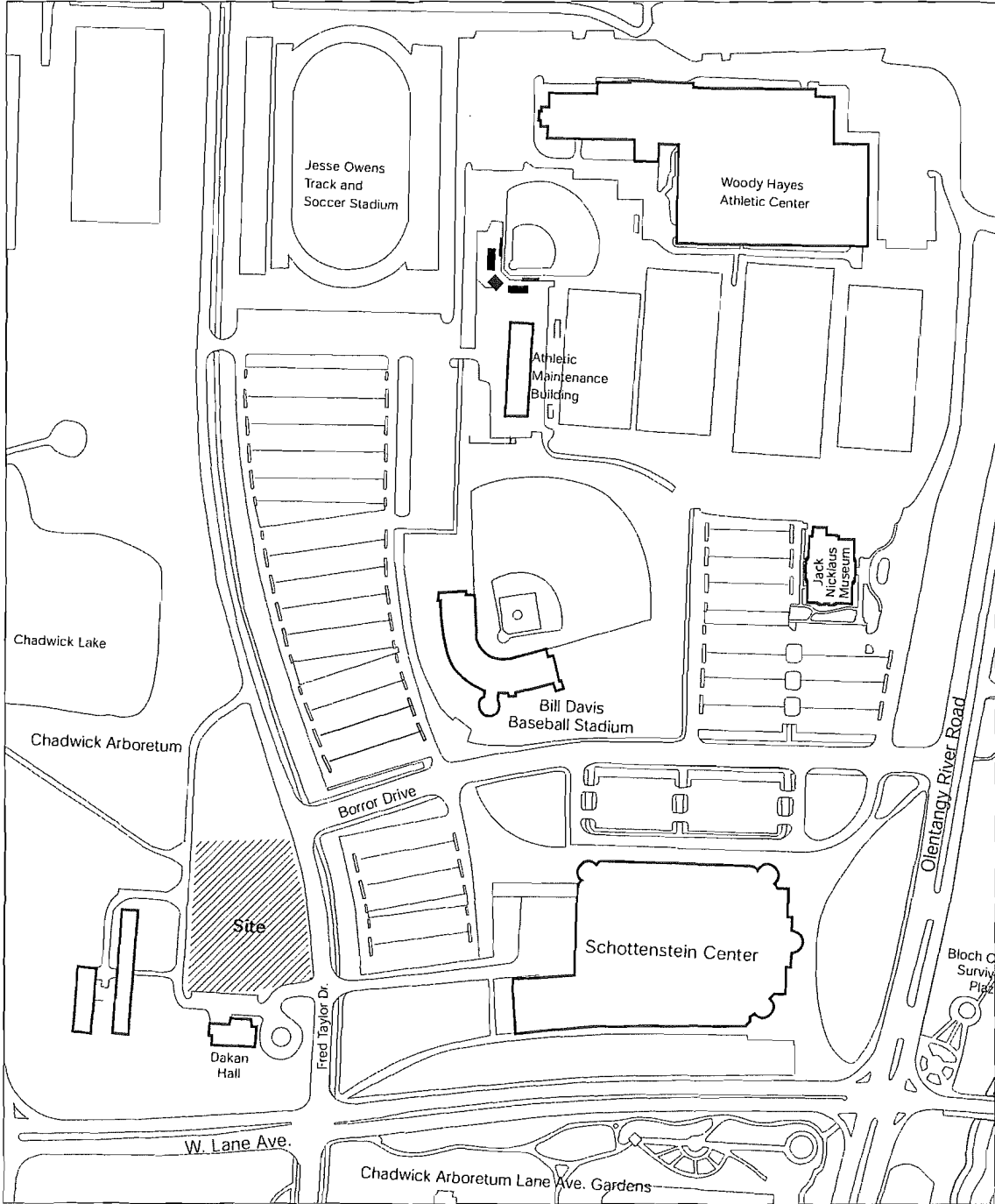

(APPENDIX LV)

**Fiscal Affairs Committee
OSU Board of Trustees
May 30, 2003**

FY 2003-04 Tuition and Fee Recommendations

- I. Context
- II. Recommendations
- III. Implications
- IV. Conclusions
- V. Additional Information

Office of Academic Affairs
Office of Business and Finance
May 23, 2003

I. CONTEXT

A. Review of benchmarking comparison:

1. Revenues per student FTE at Ohio State (\$31,109 per FTE student) are significantly less (16.2%) than the benchmark institution average¹.
2. State support per student FTE at Ohio State is also significantly less (\$1,090 or 10%) than benchmark institutions¹.
3. If all of Ohio's 13 public assisted universities increased their Resident undergraduate fees to the maximum allowed under the Governor's proposed fee caps for Autumn Quarter 2003, Ohio State would rank 8th for continuing students (6.2% below the State average) and 6th for new students (2.2% above the State average).
4. Resident graduate fees at Ohio State are 3.2% less than the than benchmark institutions.

B. Conclusion

Ohio State continues to compete effectively with its aspirational peers with respect to academic excellence, however, relatively low levels of State support means we are increasingly at risk of falling behind in providing students with a truly outstanding education.

¹ Based on FY 01 IPEDS Financial Survey.

C. Actions to Date

The following fees have previously been approved by the Board effective Summer Quarter 2003:

1. A three-tiered budget structure for undergraduate instructional and general fees for the Columbus Campus.
2. Undergraduate instructional and general fees for the Regional Campuses.
3. Undergraduate nonresident surcharges for all campuses.

II. RECOMMENDATIONS

A. In order to maintain a competitive position financially, Ohio State needs to increase selective student fees, effective Autumn Quarter 2003.

1. The general fee for all continuing undergraduate students and all graduate and professional students effective Autumn Quarter 2003 will be \$117 per quarter (\$176 per semester). Also effective Autumn Quarter 2003, the general fee for all new undergraduate students will increase an additional \$15 per quarter (with a corresponding decrease in their instructional fees) with the additional funds earmarked for student activities. There will be a separate student activity fee of \$15 per quarter (\$22 per semester) for all new graduate and professional students with the additional funds earmarked for student activities. In three years all undergraduate students will pay the higher general fee and all graduate and professional students will pay the student activity fee, generating approximately \$2 million for student learning outside the classroom activities.
2. Masters & PhD instructional and general fees will increase \$594 per year (9.0%), or \$198 per quarter for continuing students and will increase \$639 per year (9.7%), or \$213 per quarter for new students. The non-resident surcharge for all graduate students will increase \$636 per year (6.0%), or \$212 per quarter.
3. Increases above 6.0% are recommended for professional and graduate student instructional fees on a selected basis in the

colleges of Business, Dentistry, Law, Medicine, Optometry, Pharmacy, and Veterinary Medicine.

4. Other student fees including Housing & Food Service, Learning Technology fees, Student Insurance, Parking, and Recreational among others also need to be approved for FY 2003-04 in order to continue to provide quality services to students.

B. Instructional fees for most Masters and PhD students will increase 9% and for selected Graduate and Professional programs will increase by a base of 6%. Differential Fee Increases¹ above the 6% base are recommended for the 11 graduate and professional programs listed below². These monies will be used to improve services to students in those colleges inside and outside the classroom. The nonresident surcharges for all Graduate and Professional programs will also increase by 6%. One of the programs is new in FY 2004 – Masters in Occupational Therapy.

College	FY 03	FY 2004 Increases			
	Instrn'l Fees	Resident Instructional Fee		Non-Resident Surcharge ³	
		% Chg	\$ Chg	% Chg	\$ Chg
EMBA	\$28,971	8.5%	\$2,457	6.0%	\$636
Dentistry	13,989	12.0%	1,680	6.0%	1,302
Law (semester)	11,520	10.0%	1,152	6.0%	686
Medicine ⁴	17,052	11.0%	1,875	6.0%	1,389
Occupational Therapy ⁵	6,252	10.0%	624	6.0%	636
Physical Therapy	6,831	10.0%	684	6.0%	636
Public Health MPH	6,549	11.0%	720	6.0%	636
Public Health PEP	6,669	9.0%	600	6.0%	636
Optometry	10,926	10.0%	1,092	6.0%	1,302
Pharmacy	8,250	12.0%	990	6.0%	675
Vet Medicine	12,828	11.0%	1,410	6.0%	1,347

¹ Annually (3 quarters or 2 semesters), unless indicated otherwise.

² MBA, Masters of Accounting, MLHR and Masters of Health Administration will increase only by the 6% base.

³ Non-resident students pay both resident and non-resident fees as well as the general fee not shown on this table.

⁴ Represents the gross instructional fees for all ranks (0,1,2 & 3). The higher ranks will receive Medicine Tuition Credits to lower their effective rates to a 10% increase for rank 1, a 9.2% for rank 2 and an 8.4% increase for rank 3.

⁵ New differential fee in FY 2004. Fee represents increase over the FY 2003 Graduate fees.

C. Other Charges and Fees

1. Summary of changes in undergraduate fees and charges:

The total cost for a resident undergraduate to attend Ohio State's Columbus Campus and live in University housing in FY 2004 will increase approximately \$946 (7.0%) for a three quarter academic year for a continuing student and \$1,288 (9.2%) for a three quarter academic year for a new student.

Fees and Charges	Continuing Students		New Students	
	Percent Increase	Dollar Increase	Percent Increase	Dollar Increase
Tuition	9.0%	\$468	14.3%	\$810
Room & Board ¹	3.7%	231	3.7%	231
Books & Supplies	3.0%	29	3.0%	29
Health Insurance ²	23.7%	204	23.7%	204
Park & OSU Bus ³	5.2%	9	5.2%	9
COTA Bus Pass	0.0%	0	0.0%	0
Football Tickets	4.8%	5	4.8%	5
Basketball Tickets	0.0%	0	0.0%	0
Total	7.0%	\$946	9.2%	\$1,288

¹ Represents the average undergraduate room rates plus the 10-meal plan.

² Based on the single comprehensive rate.

³ Rates are for the Columbus Campus. West Campus rates are increasing \$20 (47%).

2. Learning Technology Fees:

Several colleges and programs have established Learning Technology fees in the past in order to fund the additional technology needed to remain competitive within their fields. Only selected fees are proposed to increase in FY 2004.

	FY 2003		FY 2004	
	Under-grad	Grad	Under-grad	Grad
College of Arts	\$43.00	\$43.00	\$50.00	\$50.00
College of Business	85.00	120.00	97.00	138.00
College of Engineering	110.00	120.00	110.00	120.00
College of Nursing	43.00	43.00	50.00	50.00
Dept of CIS in MAPS	73.00	80.00	73.00	80.00
School of Public Pol & Mgt	NA	120.00	NA	120.00

3. Other Increases are as follows:

Application Fees-Domestic ¹	\$10 increase (\$30 to \$40)
Acceptance Fees-Undergraduate ¹	\$30 increase (\$70 to \$100)
Orientation Fee ¹	New of \$30
Transcript Fee ¹	\$2 increase (\$5 to \$7)
Basic Telephone Service	7% decrease
Faculty & Staff Parking	4%-5% increase
Faculty & Staff Health Insurance ²	19% increase
University Health System ³	11.6% increase

¹ Additional revenue will support Undergraduate Student programs and services.

² Traditional and OSUHP plans increasing 4.0%, Prime Care increasing 19% and Buckeye increasing 40% (due to multi-year phase in of cost differences based on plan design).

³ This is a weighted average of all Health System rates.

IV. CONCLUSIONS

- A. Ohio State is an excellent value for Ohio taxpayers, but is not as well funded as its competitors.
- B. Ohio State students expect and deserve the same or better level of service as students elsewhere.
- C. Ohio State will strive to continue to make improvements in the quality of services to students in FY 2004 despite low levels of State support.
- D. Ohio State continues to compete effectively with its aspirational peers with respect to academic excellence. However, relatively low levels of state financial support means we will continue to be at risk of falling behind in providing students with a truly outstanding education.